

Product Approval Code Specifications

As required by Florida Statute 553.842 and Florida Administrative Code 8B-72, please provide the information and approval numbers on the building components listed below if they will be utilized on the construction project for which you are applying for a building permit. We recommend you contact your local supplier should you not know the product approval number for any of the applicable listed products. Statewide approved products are listed online @ www.floridabuilding.org *Paper form not required if online submittal for roofs ONLY

Category/Subcategory	Manufacturer	Product Description	Approval Number(s)
1. Exterior Doors			
A. Swinging			
B. Sliding			
C. Sectional/Roll Up			
D. Other			
2. Windows			
A. Single/Double Hung			
B. Horizontal Slider			
C. Casement			
D. Fixed			
E. Mullion			
F. Skylights			
G. Other			
3. Panel Walls			
A. Siding			
B. Soffits			
C. Storefronts			
D. Glass Block			
E. Other			
4. Roofing Products			
A. Asphalt Shingles			
B. Non-Struct Metal	<i>Tri County</i>	<i>Zaga Galum</i>	<i>36904 R10</i>
C. Roofing Tiles			
D. Single Ply Roof			
E. Other			
5. Struct Componenets			
A. Wood Connectors			
B. Wood Anchors			
C. Truss Plates			
D. Insulation Forms			
E. Lintels			
F. Others			
6. New Exterior			
A. Envelope Products			



CREEK

TECHNICAL SERVICES, LLC

Registry No. 29824
 17520 Edinburgh Dr
 Tampa, FL 33647
 (813) 480-3421

EVALUATION REPORT

FLORIDA BUILDING CODE, 8TH EDITION (2023)

Manufacturer: TRI COUNTY METALS
 301 SE 16th Street
 Trenton, FL 32693
 (877) 766-3309
www.tricountymetals.com

Issued December 23, 2023

Manufacturing Locations: Trenton, FL

Quality Assurance: PRI Construction Materials Technologies (QUA9110)

*New
 FL # 36904-
 R10
 for Rib
 Panel*

SCOPE

Category: Roofing
Subcategory: Metal Roofing
Code Edition: Florida Building Code, 8th Edition (2023)
Code Sections: 1504.3, 1504.3.2
Properties: Wind Resistance

REFERENCES

Entity	Report No.	Standard	Year		
Force Engineering & Testing, Inc. (TST5328)	136-0027T-12A,B	TAS 125	2003		
		UL 580	2006		
		UL 1897	2015		
Force Engineering & Testing, Inc. (TST5328)	136-0027T-12C	FM 4471	1992		
		Force Engineering & Testing, Inc. (TST5328)	136-0044T-14A,B	TAS 125	2003
Force Engineering & Testing, Inc. (TST5328)	136-0084T-14A,B	UL 580	2006		
		UL 1897	2015		
		TAS 125	2003		
Force Engineering & Testing, Inc. (TST5328)	136-0087T-13	UL 580	2006		
		UL 1897	2015		
		TAS 125	2003		
Force Engineering & Testing, Inc. (TST5328)	136-0099T-14A,B	UL 580	2006		
		UL 1897	2015		
		TAS 125	2003		
Force Engineering & Testing, Inc. (TST5328)	136-0172T-12A,B	UL 580	2006		
		UL 1897	2015		
		TAS 125	2003		
Force Engineering & Testing, Inc. (TST5328)	136-0172T-12C,D	UL 580	2006		
		UL 1897	2015		
		TAS 125	2003		
Force Engineering & Testing, Inc. (TST5328)	136-0172T-12E	FM 4471	1992		
		Force Engineering & Testing, Inc. (TST5328)	136-0173T-12A,B	TAS 125	2003
		UL 580	2006		
Force Engineering & Testing, Inc. (TST5328)	136-0173T-12C,D	UL 1897	2015		
		TAS 125	2003		
		UL 580	2006		
Force Engineering & Testing, Inc. (TST5328)	136-0299T-13	UL 1897	2015		
		TAS 125	2003		
		UL 580	2006		
		UL 1897	2015		



Entity	Report No.	Standard	Year
Force Engineering & Testing, Inc. (TST5328)	136-0408T-09A,B	TAS 125	2003
		UL 580	2006
Force Engineering & Testing, Inc. (TST5328)	136-0408T-09C	UL 1897	2015
		FM 4471	1992
PRI Construction Materials Technologies (TST5878)	945T0002	ASTM B 117	2016
PRI Construction Materials Technologies (TST5878)	945T0004	ASTM G 155	2013
PRI Construction Materials Technologies (TST5878)	1272T0002	ASTM B 117	2016
PRI Construction Materials Technologies (TST5878)	1272T0003	TAS 110	2000
		ASTM B 117	2016
PRI Construction Materials Technologies (TST5878)	1272T0005	TAS 110	2000
		ASTM G 155	2013
PRI Construction Materials Technologies (TST5878)	1272T0006	TAS 110	2000
		ASTM G 155	2013
PRI Construction Materials Technologies (TST5878)	1930T0001	TAS 110	2000
		TAS 125	2003
PRI Construction Materials Technologies (TST5878)	1930T0002	UL 580	2006
		UL 1897	2015
PRI Construction Materials Technologies (TST5878)	1930T0002	TAS 125	2003
		UL 580	2006
PRI Construction Materials Technologies (TST5878)	1930T0003	UL 1897	2015
		TAS 125	2003
PRI Construction Materials Technologies (TST5878)	1930T0003	UL 580	2006
		UL 1897	2015
PRI Construction Materials Technologies (TST5878)	1930T0004	TAS 125	2003
		UL 580	2006
PRI Construction Materials Technologies (TST5878)	1930T0004	UL 1897	2015
		TAS 125	2003
PRI Construction Materials Technologies (TST5878)	1930T0009	UL 580	2006
		UL 1897	2015
PRI Construction Materials Technologies (TST5878)	1930T0010	FM 4471	1992
PRI Construction Materials Technologies (TST5878)	1930T0010	ASTM B 117	2016
PRI Construction Materials Technologies (TST5878)	1930T0011	TAS 110	2000
		ASTM G 155	2013
PRI Construction Materials Technologies (TST5878)	1930T0013	TAS 110	2000
		TAS 125	2003
PRI Construction Materials Technologies (TST5878)	1930T0013	UL 580	2006
		UL 1897	2015
PRI Construction Materials Technologies (TST5878)	1930T0015	UL 580	2006
		UL 1897	2015
PRI Construction Materials Technologies (TST5878)	1930T0016	TAS 125	2003
		UL 580	2006
PRI Construction Materials Technologies (TST5878)	1930T0016	UL 1897	2015
		TAS 125	2003
PRI Construction Materials Technologies (TST5878)	1930T0017	UL 580	2006
		UL 1897	2015
PRI Construction Materials Technologies (TST5878)	1930T0017	ASTM E 1592	2005(2017)
PRI Construction Materials Technologies (TST5878)	1930T0018	TAS 125	2003
		UL 580	2006
PRI Construction Materials Technologies (TST5878)	1930T0019	UL 1897	2015
		UL 580	2006
PRI Construction Materials Technologies (TST5878)	1930T0019	UL 1897	2015
		TAS 125	2003
PRI Construction Materials Technologies (TST5878)	1930T0020	UL 580	2006
		UL 1897	2015
PRI Construction Materials Technologies (TST5878)	1930T0026	TAS 125	2003
		UL 580	2006
PRI Construction Materials Technologies (TST5878)	1930T0026	UL 1897	2015
		TAS 125	2003
PRI Construction Materials Technologies (TST5878)	1930T0027	UL 580	2006
		UL 1897	2015
PRI Construction Materials Technologies (TST5878)	1930T0027	TAS 125	2003
		UL 580	2006
PRI Construction Materials Technologies (TST5878)	1930T0028	UL 1897	2015
		ASTM C 794	2001
PRI Construction Materials Technologies (TST5878)	1930T0029	TAS 125	2003
		UL 580	2006
PRI Construction Materials Technologies (TST5878)	1930T0029	UL 1897	2015
		TAS 125	2003
PRI Construction Materials Technologies (TST5878)	1930T0031	UL 580	2006
		UL 1897	2015
PRI Construction Materials Technologies (TST5878)	1930T0031	TAS 125	2003
		UL 580	2006
PRI Construction Materials Technologies (TST5878)	1930T0032	UL 1897	2015
		TAS 125	2003
PRI Construction Materials Technologies (TST5878)	1930T0032	UL 580	2006
		UL 1897	2015



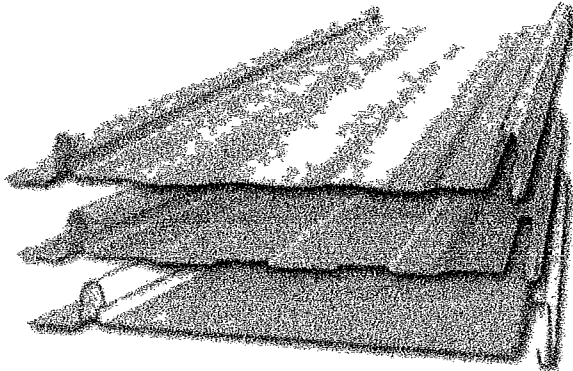
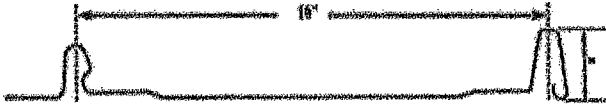
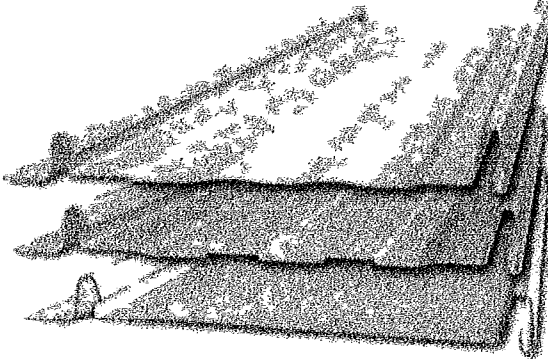
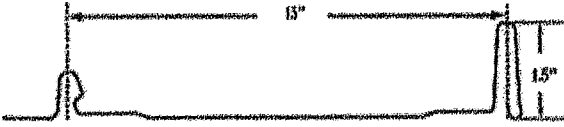

<u>Entity</u>	<u>Report No.</u>	<u>Standard</u>	<u>Year</u>
PRI Construction Materials Technologies (TST5878)	1930T0034.1	TAS 125	2003
		UL 580	2006
PRI Construction Materials Technologies (TST5878)	1930T0035	UL 1897	2015
		UL 580	2006
PRI Construction Materials Technologies (TST5878)	1930T0036.1	UL 1897	2015
		TAS 125	2003
PRI Construction Materials Technologies (TST5878)	1930T0037.1	UL 580	2006
		UL 1897	2015
PRI Construction Materials Technologies (TST5878)	1930T0037.1	TAS 125	2003
		UL 580	2006
PRI Construction Materials Technologies (TST5878)	1930T0038	UL 1897	2015
		TAS 125	2003
PRI Construction Materials Technologies (TST5878)	1930T0038	UL 580	2006
		UL 1897	2015
PRI Construction Materials Technologies (TST5878)	1930T0039.2	TAS 125	2003
		UL 580	2006
PRI Construction Materials Technologies (TST5878)	1930T0040	UL 1897	2015
		TAS 125	2003
PRI Construction Materials Technologies (TST5878)	1930T0040	UL 580	2006
		UL 1897	2015
PRI Construction Materials Technologies (TST5878)	1930T0042	FM 4471	1992
PRI Construction Materials Technologies (TST5878)	1930T0045	UL 580	2006
		UL 1897	2015
PRI Construction Materials Technologies (TST5878)	1930T0046	TAS 125	2003
		UL 580	2006
		UL 1897	2015

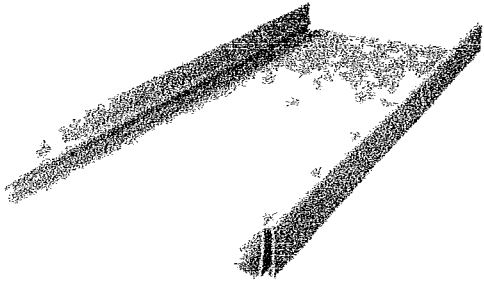
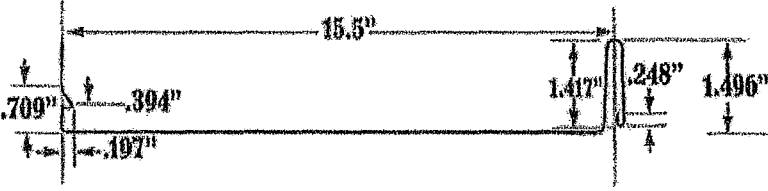
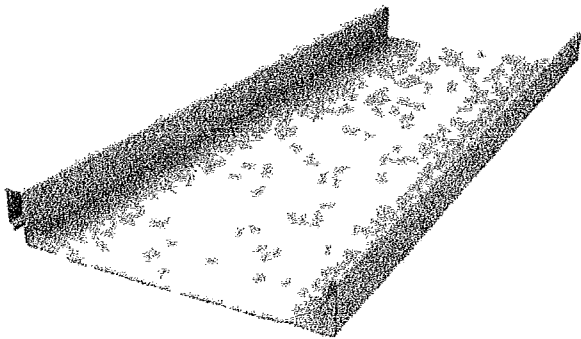
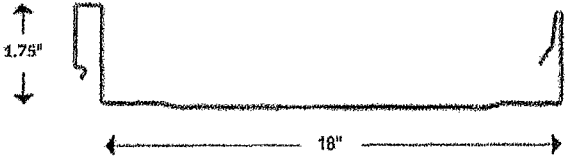
PRODUCT DESCRIPTION

TCM-LOK 1 in.	Profile:	1 in. snap lock seam; Max. 16 in. coverage
	Description:	Non-structural, snap lock standing seam roof panel with 7/8 in. slotted nail strip
	Material:	Min. 26 ga. ($F_y = \text{min. } 50 \text{ ksi}$) ASTM A653 G90, ASTM A792 AZ50 steel coated with Fluropon® or WeatherXL or ASTM A792 AZ55 steel ; or Min. 0.032in. ($F_y = \text{min. } 25 \text{ ksi}$) ASTM B209, 3105 H22 aluminum coated with Fluropon®; Shall conform with FBC Section 1507.4.3
 		
TCM-LOK 1.5 in.	Profile:	1.5 in. snap lock seam; Max. 15 in. coverage
	Description:	Non-structural, snap lock standing seam roof panel with 7/8 in. slotted nail strip
	Material:	Min. 24 ga. ($F_y = \text{min. } 50 \text{ ksi}$) ASTM A653 G90, ASTM A792 AZ50 steel coated with Fluropon® or WeatherXL or ASTM A792 AZ55 steel; Shall conform with FBC Section 1507.4.3
 		

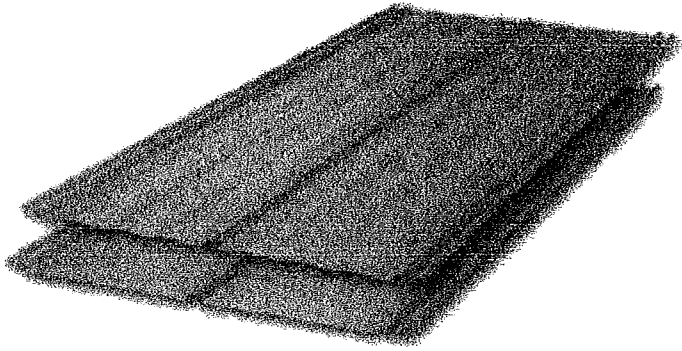
<p>1.5 SL-LOK</p>	<p>Profile: Description: Material:</p>	<p>1.5 in. snap lock seam; Max. 15.5 in. coverage</p> <p>Non-structural, snap lock standing seam roof panel</p> <p>Min. 24 ga. ($F_y = \text{min. } 50 \text{ ksi}$) ASTM A653 G90, ASTM A792 AZ50 steel coated with Fluropon® or WeatherXL or ASTM A792 AZ55 steel; or Min. 0.032 in. ($F_y = \text{min. } 25 \text{ ksi}$) ASTM B209, 3105 H24 aluminum coated with Fluropon®; Shall conform with FBC Section 1507.4.3</p>  
<p>1.75 SS-LOK</p>	<p>Profile: Description: Material:</p>	<p>1.75 in. snap lock standing seam; Max. 18 in. coverage</p> <p>Non-structural, snap lock standing seam roof panel</p> <p>Min. 24 ga. ($F_y = \text{min. } 50 \text{ ksi}$) ASTM A653 G90, ASTM A792 AZ50 steel coated with Fluropon® or WeatherXL or ASTM A792 AZ55 steel; or Min. 0.040 in. ($F_y = \text{min. } 25 \text{ ksi}$) ASTM B209, 3104 H22 aluminum coated with Fluropon®; Shall conform with FBC Section 1507.4.3</p>  

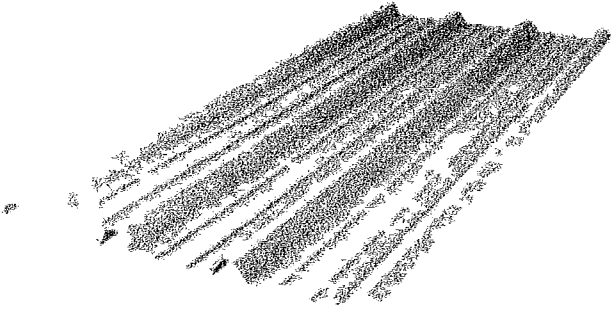
<p>1.5 MS-LOK</p>	<p>Profile:</p>	<p>1.5 in. mechanical seam; Max. 16 in. coverage</p>
<p>Description:</p>	<p>Non-structural, standing seam roof panel; 180° double lock mechanical seam</p>	
<p>Material:</p>	<p>Min. 24 ga. (F_y = min. 50 ksi) ASTM A653 G90, ASTM A792 AZ50 steel coated with Fluoropon® or WeatherXL or ASTM A792 AZ55 steel; Shall conform with FBC Section 1507.4.3</p>	
<p>2 MS-LOK</p>	<p>Profile:</p>	<p>2 in. mechanical seam; Max. 18.75 in. coverage</p>
<p>Description:</p>	<p>Non-structural, standing seam roof panel; 180° double lock mechanical seam</p>	
<p>Material:</p>	<p>Min. 24 ga. (F_y = min. 50 ksi) ASTM A653 G90, ASTM A792 AZ50 steel coated with Fluoropon® or WeatherXL or ASTM A792 AZ55 steel; Shall conform with FBC Section 1507.4.3</p>	

5V	<p>Profile: 3/8 in. ribs at 12 in. o.c.; 24 in. coverage</p> <p>Description: Non-structural, through fastened roof panel</p> <p>Material: Min. 26 ga. ($F_y = \text{min. } 50 \text{ ksi}$) ASTM A653 G90, ASTM A792 AZ50 steel coated with Fluoropon® or WeatherXL or ASTM A792 AZ55 steel; or Min. 0.032 in. ($F_y = \text{min. } 27 \text{ ksi}$) ASTM B209, 3105 H22 aluminum coated with Fluoropon®; Shall conform with FBC Section 1507.4.3</p>	 
PBR	<p>Profile: 1-1/4 in. ribs at 12 in. o.c.; 36 in. coverage</p> <p>Description: Non-structural, through fastened roof panel</p> <p>Material: Min. 26 ga. ($F_y = \text{min. } 80 \text{ ksi}$) ASTM A653 G90, ASTM A792 AZ50 steel coated with Fluoropon® or WeatherXL or ASTM A792 AZ55 steel; Shall conform with FBC Section 1507.4.3</p>	 

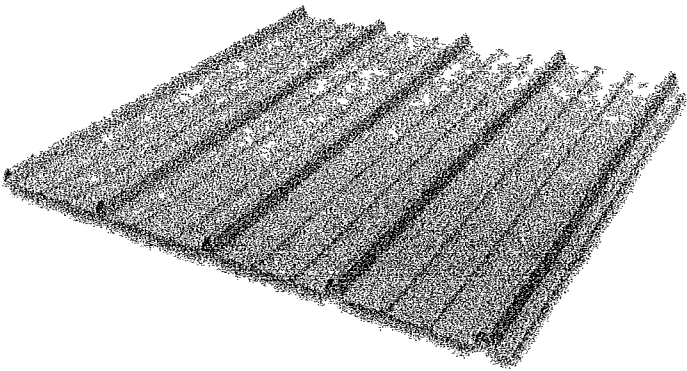
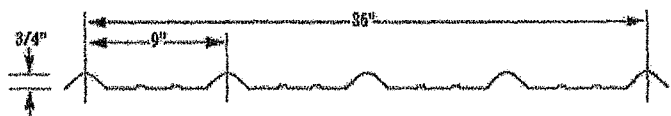
Ultra Rib	Profile:	3/4 in. ribs at 9 in. o.c.; 36 in. coverage
	Description:	Non-structural, through fastened roof panel
	Material:	Min. 29 ga. (F _y = min. 80 ksi) or Min. 26 ga. (F _y = min. 50 ksi) ASTM A653 G90, ASTM A792 AZ50 steel coated with Fluropon® or WeatherXL or ASTM A792 AZ55 steel; Shall conform with FBC Section 1507.4.3
		
		

LIMITATIONS

1. This report is not for use in the HVHZ.
2. Fire classification is not within the scope of this evaluation.
3. The roof deck, wood battens and their attachment shall be designed by others to meet the minimum design loads established for components and cladding and in accordance with FBC requirements.
4. Roof slope shall be in accordance with FBC Section 1507.4.2
5. Reroofing shall be in accordance with Section 1511.
6. Installation of the evaluated products shall comply with this report, the FBC, and the manufacturer's published application instructions. Where discrepancies exist between these sources, the more restrictive and FBC compliant installation detail shall prevail.
7. All products listed in this report shall be manufactured under a quality assurance program in compliance with Rule 61G20-3.

COMPLIANCE STATEMENT

The products evaluated herein by Zachary R. Priest, P.E. have demonstrated compliance with the Florida Building Code, 8th Edition (2023) as evidenced in the referenced documents submitted by the named manufacturer.

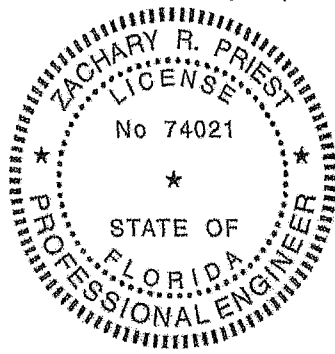

This item has been digitally signed and sealed by Zachary R. Priest, PE, on 12/23/2023.

Printed copies of this document are not considered signed and sealed and the signature must be verified on any electronic copies.

2023.12.23
 11:22:54
 -05'00'

Zachary R. Priest, P.E.
 Florida Registration No. 74021
 Organization No. ANE9641

CERTIFICATION OF INDEPENDENCE

CREEK Technical Services, LLC does not have, nor will it acquire, a financial interest in any company manufacturing or distributing products under this evaluation.

CREEK Technical Services, LLC is not owned, operated, or controlled by any company manufacturing or distributing products under this evaluation.

Zachary R. Priest, P.E. does not have, nor will acquire, a financial interest in any company manufacturing or distributing products under this evaluation.

Zachary R. Priest, P.E. does not have, nor will acquire, a financial interest in any other entity involved in the approval process of the product.

APPENDICES

- 1) APPENDIX A – Installation (5 pages)
- 2) APPENDIX B – Approved Roof Systems (11 pages)
- 3) APPENDIX C – Design Wind Loads (4 pages)

Fastening Details	
Nomenclature	Attachment
PBR Type 2	<p>#14 x 7/8 LAP SCREW @ 24" O.C.</p> <p>WOODGRIP W/ WASHER</p>
Ultra Rib 1	<p>(1) HWH wood screw w/sealing washer</p>
Ultra Rib 2	<p>WOODGRIP w/ SEALING WASHER</p>
Ultra Rib 3	<p>(1) HWH wood screw w/sealing washer</p>
Ultra Rib 4	<p>WOODGRIP w/ SEALING WASHER</p>

Fastening Details	
Nomenclature	Attachment
TCM-LOK	<p>3/8" bead TiteBond WeatherMaster Metal Roof Sealant</p> <p>(1) #10-12 TYPE A PANCAKE</p>
5V Type 1	<p>(1) HWH wood screw w/sealing washer</p> <p>12" 12"</p> <p>At Panel Lap</p>
5V Type 2	<p>12" 12"</p> <p>(1) #9 x 1 1/2" WOODGRIP w/WASHER</p>
5V Type 3	<p>10" 1 1/2" 10"</p> <p>(1) #9 x 1 1/2" WOODGRIP w/WASHER</p>
PBR Type 1	<p>7" 5" 7" 5" 7" 5"</p> <p>WOODGRIP W/ WASHER</p> <p>#14 x 7/8 LAP SCREW @ 24" O.C.</p>

INSTALLATION

Note - Refer to the **APPROVED ROOF SYSTEMS** section of this report for specific installation details of a selected system.

Unless otherwise specified in this report the following installation details shall be met for the named products:

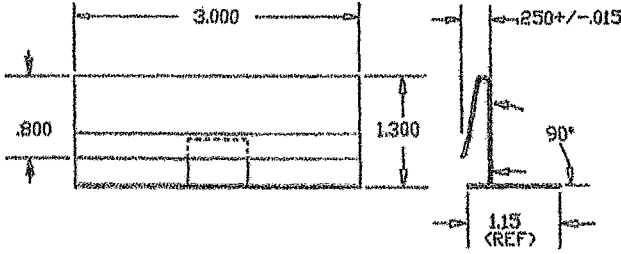
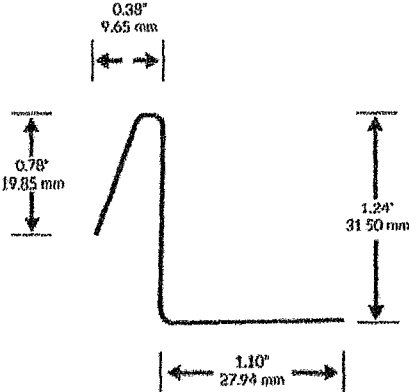
Component	Product	Installation Detail
Fasteners	#10-12 Pancake Type A screw	Shall penetrate through the sheathing a minimum 3/8 in. Shall be corrosion resistant in accordance with FBC section 1507.4.4.
	#10-9 PanclipSS MTW low profile head wood screw	
	#10-9 Panclip MTW low profile head wood screw	
	#9-15 Woodgrip HWH wood screw with sealing washer	
	#9-15 Evergrip HWH wood screw with sealing washer	
	#12-8 Woodgrip XG HWH wood screw with sealing washer	
		#14-13 PANCLIP SD-L low profile head self-drilling screw
Bearing Plate	Universal Bearing Plate	4" x 5", 20ga. galvanized steel bearing plate from Direct Metals, Inc.
Clips	1.5 in. DM SL Clip	<p>24 ga. Direct Metals Inc Snaplock HD 450HD Clip, 1-1/4" - 1-1/2" Utility Snaplock Clip, 1.3 in. tall with 3 in. base</p> 
	1.5 in. SL Continuous Clip	<p>24 ga. ASTM A792 AZ55 or 0.032" ASTM B209, 3105 H24 Al; 1.24 in. tall with 1.1 in. base, Min. 10 ft. length</p> 

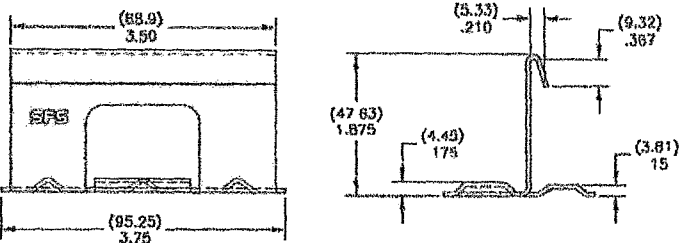
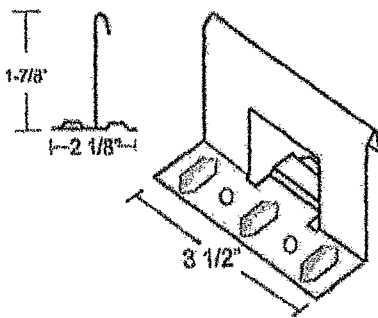
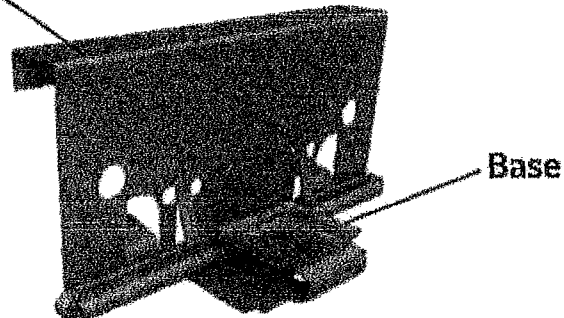
Component	Product	Installation Detail
Clips – Cont'd	1.75 in. SFS SL Clip	18 ga. SFS 1-3/4 in. Snap Lock Clip; 1.875 in. tall with 3.75 in. base 
	1.75 in. DM SL Clip	18 ga. Direct Metals Inc 1-3/4 in. Snap Lock Clip; 1-7/8 in. tall with 3-1/2 in. base 
	1.5 in. ML Clip	1-1/2 in. 1-piece expansion clip; 22 ga. vertical tab; 16 ga. base; 4.5 in. long Vertical Tab  Base

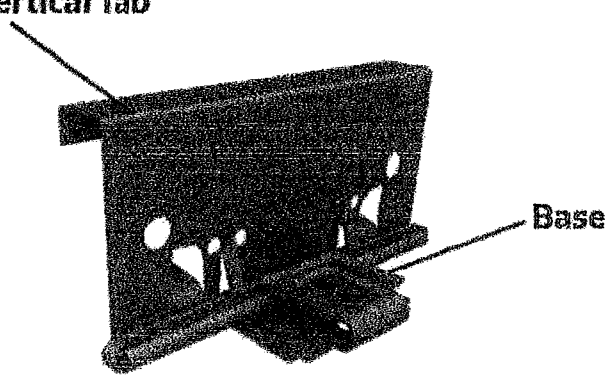
Component	Product	Installation Detail
Clips – Cont'd	2 In. ML Clip	2 in. 1-piece expansion clip; 22 ga. vertical tab; 16 ga. base; 4.5 in. long 
Seam Sealant	TiteBond Weathermaster Metal Roof Sealant Geocel 2300 Novaflex Metal Roof Sealant	Shall be applied in 1/4 in.- 5/16 in. continuous beads on the male rib along the seam

APPROVED ROOF SYSTEMS

The following notes shall be observed when using the assembly tables below.

1. Maximum Design Pressure (MDP) was calculated using a 2:1 margin of safety per FBC Section 1504.9.
2. Refer to **LIMITATIONS** and sections of this evaluation when using the table(s) below.
3. Refer to **INSTALLATION** section of this report for installation detail when the information is not explicitly stated for the selected assembly.
4. The on-center (o.c.) spacing given is the maximum allowable attachment spacing for the rated system.
5. Unless otherwise specified, Steel Deck shall be designed by others in accordance with FBC requirements and shall be minimum 22 ga, Wide Rib Deck (Type WR) conforming to ANSI/SDI-RD1.0 & FBC and shall be attached to structural supports spaced maximum 5ft o.c. Panel seams shall be installed perpendicular to the steel deck ribs.
6. Wood Deck shall be designed by others in accordance with FBC requirements and shall be minimum APA Span-Rated sheathing at maximum 24 in. span.
7. No. 2 SYP wood battens used over solidly sheathed decks shall be installed parallel to the eave and 90 degrees to the roof trusses/rafters. Wood battens shall be located under each fastener row.
8. Panel fasteners shall be installed through the battens and into the roof deck. Battens shall be secured in place with one (1) min. 0.113 in. x 2-3/8 in. ring shank nail installed max. 12 in. o.c. into the plywood deck.
9. No. 2 SYP wood battens shall be secured in place with one (1) min. 8d x 2-3/8 in. ring shank nail installed max. 4 in. o.c. into the plywood deck or two (2) min. #9 x 3 in. deck screws spaced max. 24 in. o.c. installed through the plywood deck and into the rafters/trusses.
10. No. 2 SYP wood battens shall be secured in place with one (1) min. 8d x 2-1/2 in. ring shank nail installed max. 4 in. o.c. into the plywood deck.
11. No. 2 SYP wood battens shall be secured in place with two (2) min. #9 x 3 in. deck screws spaced max. 24 in. o.c. installed through the plywood deck and into the rafters/trusses.

Roof System Numbers and Definitions	
L1-A1-W-#	Min. 0.032 Al TCM-LOK 1 in. over Wood Deck (New or Existing)
L1-S-W-#	Min. 26ga. steel TCM-LOK 1 in. over Wood Deck (New or Existing)
L1.5-S-W-#	Min. 24ga. steel TCM-LOK 1.5 in. over Wood Deck (New or Existing)
SL-A1-W-#	Min. 0.032 Al 1.5 SL-LOK over Wood Deck (New or Existing)
SL-S-W-#	Min. 24ga. steel 1.5 SL-LOK over Wood Deck (New or Existing)
SS-A1-W-#	Min. 0.040 Al 1.75 SS-LOK over Wood Deck (New or Existing)
SS-S-W-#	Min. 24ga. steel 1.75 SS-LOK over Wood Deck (New or Existing)
SS-S-S-#	Min. 24ga. steel 1.75 SS-LOK over Steel Deck (New or Existing)
1.5MS-W-#	Min. 24ga. steel 1.5 MS-LOK over Wood Deck (New or Existing)
2MS-W-#	Min. 24ga. steel 2 MS-LOK over Wood Deck (New or Existing)
2MS-S-#	Min. 24ga. steel 2 MS-LOK over Steel Deck (New or Existing)
5V-A1-W-#	Min. 0.032 Al 5V over Wood Deck (New or Existing)
5V-S-W-#	Min. 26ga. steel 5V over Wood Deck (New or Existing)
PBR-W-#	Min. 26ga. steel PBR over Wood Deck (New or Existing)
RIB-W-#	Min. 29ga. steel Ultra Rib over Wood Deck (New or Existing)

Approved Systems for Min. 0.032 Al 1 in. TCM-LOK over Wood Deck (New or Existing)						
System No.	Deck	Fire Barrier	Underlayment	Roof Panel	Panel Attachment	MDP (psf)
L1-AI-W-1	Min. 15/32 CDX plywood	OPTIONAL Approved fire barrier	As required per FBC	Min. 0.032 Al TCM-LOK 1 in. Max. 16 in. coverage	TCM-LOK attachment with #10-12 Pancake Type A screws spaced 5-1/4 in. o.c.; Seam Sealant (see INSTALLATION for list of allowable products) applied to male rib.	-110

Approved Systems for Min. 26ga. steel TCM-LOK 1 in. over Wood Deck (New or Existing)						
System No.	Deck	Fire Barrier	Underlayment	Roof Panel	Panel Attachment	MDP (psf)
L1-S-W-1	Min. 15/32 B-C plywood with OPTIONAL single layer of asphalt shingles	OPTIONAL Approved fire barrier	As required per FBC	Min. 26ga. steel TCM-LOK 1 in. Max. 16 in. coverage	#10-12 Pancake Type A screws installed 5-1/4 in. o.c. along the fastening strip into the pre-punched slots	-52.5
L1-S-W-2	Min. 15/32 B-C plywood with OPTIONAL single layer of asphalt shingles	OPTIONAL Approved fire barrier	As required per FBC	Min. 24ga. steel TCM-LOK 1 in. Max. 16 in. coverage	#10-12 Pancake Type A screws installed 5-1/4 in. o.c. along the fastening strip into the pre-punched slots	-116
L1-S-W-3	Min. 15/32 CDX plywood	OPTIONAL Approved fire barrier	As required per FBC	Min. 26ga. steel TCM-LOK 1 in. Max. 16 in. coverage	#10-12 Pancake Type A screws installed 5-1/4 in. o.c. along the fastening strip into the pre-punched slots	-123.5
L1-S-W-4	Min. 15/32 CDX plywood	OPTIONAL Approved fire barrier	As required per FBC	Min. 24ga. steel TCM-LOK 1 in. Max. 16 in. coverage	TCM-LOK attachment with #10-12 Pancake Type A screws spaced 5-1/4 in. o.c.; Seam Sealant (see INSTALLATION for list of allowable products) applied to male rib.	-142.5

APPENDIX B

Approved Systems for Min. 24ga. steel TCM-L-OK 1.5 in. over Wood Deck (New or Existing)

System No.	Deck	Fire Barrier	Underlayment	Roof Panel	Panel Attachment	MDP (psf)
L1.5-S-W-1	Min. 15/32 CDX plywood	OPTIONAL Approved fire barrier	As required per FBC	Min. 24ga. steel TCM-L-OK 1.5 in. Max. 15 in. coverage	TCM-L-OK attachment with #10-12 Pancake Type A screws spaced 5-1/4 in. o.c.; Seam Sealant (see INSTALLATION for list of allowable products) applied to male rib.	-122.5

Approved Systems Min. 0.032 Al 1.5 SL-L-OK over Wood Deck (New or Existing)

System No.	Deck	Fire Barrier	Underlayment	Roof Panel	Panel Attachment	MDP (psf)
SL-AI-W-1	Min. 15/32 CDX plywood	OPTIONAL Approved fire barrier	As required per FBC	Min. 0.032 Al 1.5 SL-L-OK Max. 15.5 in. coverage	0.032 Al 1.5 in. SL Continuous Clips installed over male leg and fastened 6 in. o.c. with one (1) #10-9 PancipSS MTW low profile head wood screw; Female portion of snap-lock is then engaged over the continuous clip	-101
SL-AI-W-2	Min. 15/32 CDX plywood	OPTIONAL Approved fire barrier	As required per FBC	Min. 0.032 Al 1.5 SL-L-OK Max. 15.5 in. coverage	0.032 Al 1.5 in. SL Continuous Clips installed over male leg and fastened 6 in. o.c. with one (1) #10-9 PancipSS MTW low profile head wood screw, 3/8 in. wide, continuous bead of NovaFlex Metal Roof Sealant is applied to backside of continuous clip; Female portion of snap-lock is then engaged over the continuous clip	-108.5

Approved Systems for Min. 24ga. steel 1.5 SL-L-OK over Wood Deck (New or Existing)

System No.	Deck	Fire Barrier	Underlayment	Roof Panel	Panel Attachment	MDP (psf)
SL-S-W-1	Min. 15/32 CDX plywood	OPTIONAL Approved fire barrier	As required per FBC	Min. 24ga. steel 1.5 SL-L-OK Max. 15.5 in. coverage	1.5 in. SL Clips spaced 12 in. o.c. at the panel seam secured with two (2) #10-12 Pancake Type A screws per clip	-75
SL-S-W-2	Min. 15/32 CDX plywood	OPTIONAL Approved fire barrier	As required per FBC	Min. 24ga. steel 1.5 SL-L-OK Max. 15.5 in. coverage	1.5 in. SL Clips spaced 6 in. o.c. at the panel seam secured with two (2) #10-12 Pancake Type A screws per clip	-90
SL-S-W-3	Min. 15/32 CDX plywood	OPTIONAL Approved fire barrier	As required per FBC	Min. 24ga. steel 1.5 SL-L-OK Max. 15.5 in. coverage	24 ga. 1.5 in. SL Continuous Clips installed over male leg and fastened 6 in. o.c. with one (1) #10-12 Pancake Type A screws; Female portion of snap-lock is then engaged over the continuous clip	-146

This evaluation report is provided for State of Florida product approval under Rule 61G20-3. The manufacturer shall notify CREEK Technical Services, LLC of any product changes or quality assurance changes throughout the duration for which this report is valid. This evaluation report does not express nor imply warranty, installation, recommended use, or other product attributes that are not specifically addressed herein.

Approved Systems for Min. 0.040 Al 1.75 SS-LOK over Wood Deck (New or Existing)

System No.	Deck	Fire Barrier	Underlayment	Roof Panel	Panel Attachment	MDP (psf)
SS-AI-W-1	Min. 15/32 CDX plywood	OPTIONAL Approved fire barrier	As required per FBC	Min. 0.040 Al 1.75 SS-LOK Max. 16 in. coverage	1.75 in. SFS SL Clips spaced 16 in. o.c. at the panel seam secured with two (2) #10-9 PanclipSS MTW low profile head screws per clip	-90
SS-AI-W-2	Min. 15/32 CDX plywood	OPTIONAL Approved fire barrier	As required per FBC	Min. 0.040 Al 1.75 SS-LOK Max. 16 in. coverage	1.75 in. SFS SL Clips spaced 6 in. o.c. at the panel seam secured with two (2) #10-9 PanclipSS MTW low profile head screws per clip	-120

Approved Systems for Min. 24ga. steel 1.75 SS-LOK over Wood Deck (New or Existing)

System No.	Deck	Fire Barrier	Underlayment	Roof Panel	Panel Attachment	MDP (psf)
SS-S-W-1	Min. 15/32 CDX plywood	OPTIONAL Approved fire barrier	As required per FBC	Min. 24ga. steel 1.75 SS-LOK Max. 18 in. coverage	1.75 in. DM SL Clips spaced 18 in. o.c. at the panel seam secured with two (2) #10-12 Pancake Type A screws per clip	-105

Approved Systems for Min. 24ga. steel 1.75 SS-LOK over Steel Deck (New or Existing)

System No.	Deck	Fire Barrier	Insulation	Underlayment	Roof Panel	Panel Attachment	MDP (psf)
SS-S-S-1	Min. 22ga. steel deck	OPTIONAL Approved fire barrier	Min. 1-inch Approved insulation board	As required per FBC	Min. 24ga. steel 1.75 SS-LOK Max. 18 in. coverage	1.75 in. DM SL Clips and Universal Bearing Plates spaced 24 in. o.c. at the panel seam secured with two (2) #14 PANCLIP SD-L fasteners per clip	-78.5

APPENDIX B

Approved Systems for Min. 24ga. steel 1.5 MS-LOK over Wood Deck (New or Existing)

System No.	Deck	Fire Barrier	Underlayment	Roof Panel	Panel Attachment	MDP (psf)
1.5MS-W-1	Min. 15/32 CDX plywood	OPTIONAL Approved fire barrier	As required per FBC	Min. 24ga. steel 1.5 MS-LOK Max. 16 in. coverage	1.5 in. ML Clips spaced 16 in. o.c. at the panel seam secured with two (2) #10-9 x min. 1.5 in. Panclip MTW low profile screws per clip; Panels mechanically seamed with 180° double lock	-142.5
1.5MS-W-2	Min. 15/32 CDX plywood	OPTIONAL Approved fire barrier	As required per FBC	Min. 24ga. steel 1.5 MS-LOK Max. 16 in. coverage	1.5 in. ML Clips spaced 6 in. o.c. at the panel seam secured with two (2) #10-9 x min. 1.5 in. Panclip MTW low profile screws per clip; Panels mechanically seamed with 180° double lock	-176

Approved Systems for Min. 24ga. steel 2 MS-LOK over Wood Deck (New or Existing)

System No.	Deck	Fire Barrier	Underlayment	Roof Panel	Panel Attachment	MDP (psf)
2MS-W-1	Min. 15/32 CDX plywood	OPTIONAL Approved fire barrier	As required per FBC	Min. 24ga. steel 2 MS-LOK Max. 18.75 in. coverage	2 in. ML Clips spaced 16 in. o.c. at the panel seam secured with two (2) #10-9 x min. 1.5 in. Panclip MTW low profile screws per clip; Panels mechanically seamed with 180° double lock	-116.25
2MS-W-2	Min. 15/32 CDX plywood	OPTIONAL Approved fire barrier	As required per FBC	Min. 24ga. steel 2 MS-LOK Max. 18.75 in. coverage	2 in. ML Clips spaced 8 in. o.c. at the panel seam secured with two (2) #10-9 x min. 1.5 in. Panclip MTW low profile screws per clip; Panels mechanically seamed with 180° double lock	-120
2MS-W-3	Min. 15/32 CDX plywood	OPTIONAL Approved fire barrier	As required per FBC	Min. 24ga. steel 2 MS-LOK Max. 18 in. coverage	2 in. ML Clips spaced 6 in. o.c. at the panel seam secured with two (2) #10-9 x min. 1.5 in. Panclip MTW low profile screws per clip; Panels mechanically seamed with 180° double lock	-153.5

This evaluation report is provided for State of Florida product approval under Rule 61G20-3. The manufacturer shall notify CREEK Technical Services, LLC of any product changes or quality assurance changes throughout the duration for which this report is valid. This evaluation report does not express nor imply warranty, installation, recommended use, or other product attributes that are not specifically addressed herein.



TECHNICAL SERVICES, LLC

TRI COUNTY METALS
Metal Roofing (non-HVHZ)

APPENDIX B

Approved Systems for Min. 24ga. steel 2 MS-LOK over Steel Deck (New or Existing)							
System No.	Deck	Fire Barrier	Insulation	Underlayment	Roof Panel	Panel Attachment	MDP (psf)
2MS-S-1	Min. 22ga. steel deck	OPTIONAL Approved fire barrier	Min. 1-inch Approved insulation board	As required per FBC	Min. 24ga. steel 2 MS-LOK Max. 18 in. coverage	2 in. ML Clips and Universal Bearing Plates spaced 24 in. o.c. at the panel seam secured with two (2) #14 PANCLIP SD-L fasteners per clip; Panels mechanically seamed with 180° double lock	-112.25
2MS-S-2	Min. 22ga. steel deck	OPTIONAL Approved fire barrier	Min. 1-inch Approved insulation board	As required per FBC	Min. 24ga. steel 2 MS-LOK Max. 18 in. coverage	2 in. ML Clips and Universal Bearing Plates spaced 6 in. o.c. at the panel seam secured with two (2) #14 PANCLIP SD-L fasteners per clip; Panels mechanically seamed with 180° double lock	-168.5

Approved Systems for Min. 0.032 Al 5V Crimp over Wood Deck (New or Existing)							
System No.	Deck	Battens (Note 7)	Fire Barrier	Underlayment	Roof Panel	Panel Attachment	MDP (psf)
5V-AI-W-1	Min. 15/32 CDX plywood	-	OPTIONAL Approved fire barrier	As required per FBC	Min. 0.032 Al 5V Crimp Max. 24 in. coverage	5V Type 1 attachment with #9-15 Evergrip screws with sealing washers spaced 9 in. o.c.	-127.5
5V-AI-W-2	Min. 15/32 CDX plywood	-	OPTIONAL Approved fire barrier	As required per FBC	Min. 0.032 Al 5V Crimp Max. 24 in. coverage	5V Type 1 attachment with #9-15 Evergrip screws with sealing washers spaced 6 in. o.c.	-150

TC120001.10a

FL36904-R10

Page 6 of 11

This evaluation report is provided for State of Florida product approval under Rule 61G20-3. The manufacturer shall notify CREEK Technical Services, LLC of any product changes or quality assurance changes throughout the duration for which this report is valid. This evaluation report does not express nor imply warranty, installation, recommended use, or other product attributes that are not specifically addressed herein.

Approved Systems for Min. 26ga. steel 5V Crimp over Wood Deck (New or Existing)							
System No.	Deck	Battens (Note Z)	Fire Barrier	Underlayment	Roof Panel	Panel Attachment	MDP (psf)
5V-S-W-1	Min. 15/32 CDX plywood	-	OPTIONAL Approved fire barrier	As required per FBC	Min. 26ga. steel, Grade 50 5V Crimp Max. 24 in. coverage	5V Type 1 attachment with #9-15 Woodgrip screws with sealing washers spaced 16 in. o.c.	-67.5
5V-S-W-2	Min. 15/32 B-C plywood with OPTIONAL single layer of asphalt shingles	No. 2 SYP min. 1x4 wood battens secured per Note 9	OPTIONAL Approved fire barrier	As required per FBC	Min. 26ga. steel, Grade 80 5V Crimp Max. 24 in. coverage	5V Type 2 attachment into wood battens with #9-15 x min. 1.5-inch Woodgrip screws with sealing washers spaced 16 in. o.c.	-78.5
5V-S-W-3	Min. 15/32 CDX plywood	OPTIONAL No. 2 SYP min. 1x4 wood battens secured per Note 8	OPTIONAL Approved fire barrier	As required per FBC	Min. 26ga. steel, Grade 80 5V Crimp Max. 24 in. coverage	5V Type 1 attachment with #12-8 Woodgrip XG screws with sealing washers spaced 16 in. o.c.	-86.25
5V-S-W-4	Min. 15/32 CDX plywood	OPTIONAL No. 2 SYP min. 1x4 wood battens secured per Note 8	OPTIONAL Approved fire barrier	As required per FBC	Min. 26ga. steel, Grade 80 5V Crimp Max. 24 in. coverage	5V Type 1 attachment with #9-15 Woodgrip or #12-8 Woodgrip XG screws with sealing washers spaced 12 in. o.c.	-90
5V-S-W-5	Min. 15/32 B-C plywood with OPTIONAL single layer of asphalt shingles	No. 2 SYP min. 1x4 wood battens secured per Note 9	OPTIONAL Approved fire barrier	As required per FBC	Min. 26ga. steel, Grade 80 5V Crimp Max. 24 in. coverage	5V Type 3 attachment into wood battens with #9-15 x min. 1.5-inch Woodgrip screws with sealing washers spaced 16 in. o.c.	-101
5V-S-W-6	Min. 15/32 CDX plywood	-	OPTIONAL Approved fire barrier	As required per FBC	Min. 26ga. steel, Grade 50 5V Crimp Max. 24 in. coverage	5V Type 1 attachment with #12-8 Woodgrip XG screws with sealing washers spaced 12 in. o.c.	-111.25
5V-S-W-7	Min. 15/32 CDX plywood	-	OPTIONAL Approved fire barrier	As required per FBC	Min. 26ga. steel, Grade 50 5V Crimp Max. 24 in. coverage	5V Type 1 attachment with #9-15 Woodgrip or #12-8 Woodgrip XG screws with sealing washers spaced 6 in. o.c.	-120

This evaluation report is provided for State of Florida product approval under Rule 61G20-3. The manufacturer shall notify CREEK Technical Services, LLC of any product changes or quality assurance changes throughout the duration for which this report is valid. This evaluation report does not express nor imply warranty, installation, recommended use, or other product attributes that are not specifically addressed herein.

APPENDIX B

Approved Systems for Min. 26ga. steel 5V Crimp over Wood Deck (New or Existing)

System No.	Deck	Battens (Note 7)	Fire Barrier	Underlayment	Roof Panel	Panel Attachment	MDP (psf)
5V-S-W-8	Min. 15/32 CDX plywood	OPTIONAL No. 2 SYP min. 1x4 wood battens secured per Note 8	OPTIONAL Approved fire barrier	As required per FBC	Min. 26ga. steel, Grade 80 5V Crimp Max. 24 in. coverage	5V Type 1 attachment with #12-8 Woodgrip XG screws with sealing washers spaced 9 in. o.c.	-120
5V-S-W-9	Min. 15/32 CDX plywood	OPTIONAL No. 2 SYP min. 1x4 wood battens secured per Note 8	OPTIONAL Approved fire barrier	As required per FBC	Min. 26ga. steel, Grade 80 5V Crimp Max. 24 in. coverage	5V Type 1 attachment with #9-15 Woodgrip or #12-8 Woodgrip XG screws with sealing washers spaced 6 in. o.c.	-135

Approved Systems for Min. 26ga. steel PBR over Wood Deck (New or Existing)

System No.	Deck	Battens (Note 7)	Fire Barrier	Underlayment	Roof Panel	Panel Attachment	MDP (psf)
PBR-W-1	Min. 15/32 B-C plywood	-	OPTIONAL Approved fire barrier	As required per FBC	Min. 26ga. steel, Grade 80 PBR Max. 36 in. coverage	PBR Type 2 attachment with #9-15 Woodgrip screws with sealing washers spaced 24 in. o.c.	-53.5
PBR-W-2	Min. 15/32 B-C plywood with OPTIONAL single layer of asphalt shingles	No. 2 SYP min. 1x4 wood battens secured per Note 9	OPTIONAL Approved fire barrier	As required per FBC	Min. 26ga. steel, Grade 80 PBR Max. 36 in. coverage	PBR Type 2 attachment into wood battens with #9-15 x min. 1.5-inch Woodgrip screws with sealing washers spaced 24 in. o.c.	-71
PBR-W-3	Min. 15/32 B-C plywood with OPTIONAL single layer of asphalt shingles	No. 2 SYP min. 1x4 wood battens secured per Note 9	OPTIONAL Approved fire barrier	As required per FBC	Min. 26ga. steel, Grade 80 PBR Max. 36 in. coverage	PBR Type 1 attachment into wood battens with #9-15 x min. 1.5-inch Woodgrip screws with sealing washers spaced 24 in. o.c.	-73.5

This evaluation report is provided for State of Florida product approval under Rule 61G20-3. The manufacturer shall notify CREEK Technical Services, LLC of any product changes or quality assurance changes throughout the duration for which this report is valid. This evaluation report does not express nor imply warranty, installation, recommended use, or other product attributes that are not specifically addressed herein.

APPENDIX B

Approved Systems for Min. 26ga. steel PBR over Wood Deck (New or Existing)

System No.	Deck	Battens (Note 7)	Fire Barrier	Underlayment	Roof Panel	Panel Attachment	MDP (psf)
PBR-W-1	Min. 15/32 CDX plywood	OPTIONAL No. 2 SYP min. 1x4 wood battens secured per Note 8	OPTIONAL Approved fire barrier	As required per FBC	Min. 26ga. steel, Grade 80 PBR Max. 36 in. coverage	PBR Type 1 attachment with #12-8 Woodgrip XG screws with sealing washers spaced 24 in. o.c.	-86
PBR-W-2	Min. 15/32 B-C plywood	-	OPTIONAL Approved fire barrier	As required per FBC	Min. 26ga. steel, Grade 80 PBR Max. 36 in. coverage	PBR Type 1 attachment with #9-15 Woodgrip screws with sealing washers spaced 24 in. o.c.	-93.5
PBR-W-3	Min. 15/32 CDX plywood	OPTIONAL No. 2 SYP min. 1x4 wood battens secured per Note 8	OPTIONAL Approved fire barrier	As required per FBC	Min. 26ga. steel, Grade 80 PBR Max. 36 in. coverage	PBR Type 1 attachment with #12-8 Woodgrip XG screws with sealing washers spaced 12 in. o.c.	-153.5

Approved Systems for Min. 29ga. steel Ultra Rib over Wood Deck (New or Existing)

System No.	Deck	Battens (Note 7)	Fire Barrier	Underlayment	Roof Panel	Panel Attachment	MDP (psf)
RIB-W-1	Min. 7/16 OSB with OPTIONAL single layer of asphalt shingles	-	OPTIONAL Approved fire barrier	As required per FBC	Min. 29ga. steel Ultra Rib Max. 36 in. coverage	Ultra Rib 2 attachment with #12-8 Woodgrip XG screws with sealing washers spaced 24 in. o.c.	4-1.7
RIB-W-2	Min. 15/32 B-C plywood with OPTIONAL single layer of asphalt shingles	No. 2 SYP min. 1x4 wood battens secured per Note 10	OPTIONAL Approved fire barrier	As required per FBC	Min. 29ga. steel Ultra Rib Max. 36 in. coverage	Ultra Rib 4 attachment into wood battens with #9-15 x min. 2-inch Woodgrip screws with sealing washers spaced 24 in. o.c.	-52.5

This evaluation report is provided for State of Florida product approval under Rule 61G20-3. The manufacturer shall notify CREEK Technical Services, LLC of any product changes or quality assurance changes throughout the duration for which this report is valid. This evaluation report does not express nor imply warranty, installation, recommended use, or other product attributes that are not specifically addressed herein.



APPENDIX B

Approved Systems for Min. 29ga steel Ultra Rib over Wood Deck (New or Existing)							
System No.	Deck	Battens (Note Z)	Fire Barrier	Underlayment	Roof Panel	Panel Attachment	MDP (psf)
RIB-W-3	Min. 15/32 B-C plywood with OPTIONAL single layer of asphalt shingles	-	OPTIONAL Approved fire barrier	As required per FBC	Min. 29ga. steel Ultra Rib Max. 36 in. coverage	Ultra Rib 2 attachment with #9-15 Woodgrip screws with sealing washers spaced 24 in. o.c	-63.5
RIB-W-4	Min. 15/32 CDX plywood with OPTIONAL single layer of asphalt shingles	No. 2 SYP min. 1x4 wood battens secured per Note 8	OPTIONAL Approved fire barrier	As required per FBC	Min. 29ga. steel Ultra Rib Max. 36 in. coverage	Ultra Rib 2 attachment with #9-15 Woodgrip screws with sealing washers spaced 24 in. o.c	-67.5
RIB-W-5	Min. 15/32 3-ply plywood with OPTIONAL single layer of asphalt shingles	No. 2 SYP min. 1x4 wood battens secured per Note 10	OPTIONAL Approved fire barrier	As required per FBC	Min. 29ga. steel Ultra Rib Max. 36 in. coverage	Ultra Rib 2 attachment into wood battens with #9-15 x min. 1.5-inch Woodgrip screws with sealing washers spaced 24 in. o.c	-73.5
RIB-W-6	Min. 15/32 3-ply plywood with OPTIONAL single layer of asphalt shingles	No. 2 SYP min. 1x4 wood battens secured per note 10	OPTIONAL Approved fire barrier	As required per FBC	Min. 29ga. steel Ultra Rib Max. 36 in. coverage	Ultra Rib 3 attachment into wood battens with #9-15 x min. 1.5-inch Woodgrip screws with sealing washers spaced 24 in. o.c	-86
RIB-W-7	Min. 15/32 CDX plywood	No. 2 SYP min. 1x4 wood battens secured per Note 11	OPTIONAL Approved fire barrier	As required per FBC	Min. 29ga. steel Ultra Rib Max. 36 in. coverage	Ultra Rib 2 attachment into wood battens with #9-15 x min. 1.5-inch Woodgrip screws with sealing washers spaced 24 in. o.c	-93.5
RIB-W-8	Min. 15/32 B-C plywood with OPTIONAL single layer of asphalt shingles	-	OPTIONAL Approved fire barrier	As required per FBC	Min. 29ga. steel Ultra Rib Max. 36 in. coverage	Ultra Rib 3 attachment with #9-15 Woodgrip screws with sealing washers spaced 24 in. o.c	-101

This evaluation report is provided for State of Florida product approval under Rule 61G20-3. The manufacturer shall notify CREEK Technical Services, LLC of any product changes or quality assurance changes throughout the duration for which this report is valid. This evaluation report does not express nor imply warranty, installation, recommended use, or other product attributes that are not specifically addressed herein.

APPENDIX B

Approved Systems for Min. 29ga steel Ultra Rib over Wood Deck (New or Existing)							
System No.	Deck	Battens (Note 7)	Fire Barrier	Underlayment	Roof Panel	Panel Attachment	MDP (psf)
RIB-W-9	Min. 15/32 CDX plywood	OPTIONAL No. 2 SYP min. 1x4 wood battens secured per Note 8	OPTIONAL Approved fire barrier	As required per FBC	Min. 26ga. steel Ultra Rib Max. 36 in. coverage	Ultra Rib 1 attachment with #12-8 Woodgrip XG screws with sealing washers spaced 24 in. o.c	-116.25
RIB-W-10	Min. 7/16 OSB with OPTIONAL single layer of asphalt shingles	-	OPTIONAL Approved fire barrier	As required per FBC	Min. 29ga. steel Ultra Rib Max. 36 in. coverage	Ultra Rib 3 attachment with #12-8 Woodgrip XG screws with sealing washers spaced 12 in. o.c	-123.5
RIB-W-11	Min. 15/32 CDX plywood	OPTIONAL No. 2 SYP min. 1x4 wood battens secured per Note 8	OPTIONAL Approved fire barrier	As required per FBC	Min. 26ga. steel Ultra Rib Max. 36 in. coverage	Ultra Rib 1 attachment with #9-15 Woodgrip screws with sealing washers spaced 12 in. o.c	-135
RIB-W-12	Min. 15/32 B-C plywood with OPTIONAL single layer of asphalt shingles	No. 2 SYP min. 1x4 wood battens secured per Note 10	OPTIONAL Approved fire barrier	As required per FBC	Min. 29ga. steel Ultra Rib Max. 36 in. coverage	Ultra Rib 4 attachment into wood battens with #9-15 x min. 2-inch Woodgrip screws with sealing washers spaced 6 in. o.c	-131
RIB-W-13	Min. 15/32 CDX plywood	No. 2 SYP min. 1x4 wood battens secured per Note 11	OPTIONAL Approved fire barrier	As required per FBC	Min. 29ga. steel Ultra Rib Max. 36 in. coverage	Ultra Rib 3 attachment into wood battens with #9-15 x min. 1.5-inch Woodgrip screws with sealing washers spaced 24 in. o.c	-138.5

This evaluation report is provided for State of Florida product approval under Rule 61G20-3. The manufacturer shall notify CREEK Technical Services, LLC of any product changes or quality assurance changes throughout the duration for which this report is valid. This evaluation report does not express nor imply warranty, installation, recommended use, or other product attributes that are not specifically addressed herein.

DESIGN WIND LOADS

The following tables provide design wind loads for components and cladding in accordance with Section 1609 of the FBC and ASCE 7-22 under the following provisions:

1. Wind speeds for risk category I, II, III, and IV buildings shall be as defined in Section 1609 of the FBC.
2. Exposure B, C and D shall be as defined in section 1609 of the FBC.
3. Design wind load provided only for gable/hip roofs with roof slopes between 2:12 and 12:12.
4. All calculations are based on an effective wind area of 10-ft² or less.
5. Topographic factors such as escarpments or hills have been excluded from the analysis.
6. Overhangs have been excluded from the analysis.
7. Wind directionality factor, $K_d = 0.85$
8. Ground elevation factor, $K_e = 1.0$
9. V_{ult} is shown in the tables below. Design wind loads are calculated using $V_{asd} = V_{ult} \sqrt{0.6}$ per 1609.3.3.1.
10. Zone 2 applies to Zone 3 for Hip Roofs where the slope is between 2:12 and 6.1:12.
11. Projects with mean roof heights greater than 60-ft shall be evaluated by a licensed design professional.
12. Zones 1, 2, and 3 shall be defined as shown below. Dimension "a" shall be 10% of the least horizontal dimension or (0.4 x Mean Roof Height), whichever is smaller, but not less than either 4% of the least horizontal dimension or 3ft.

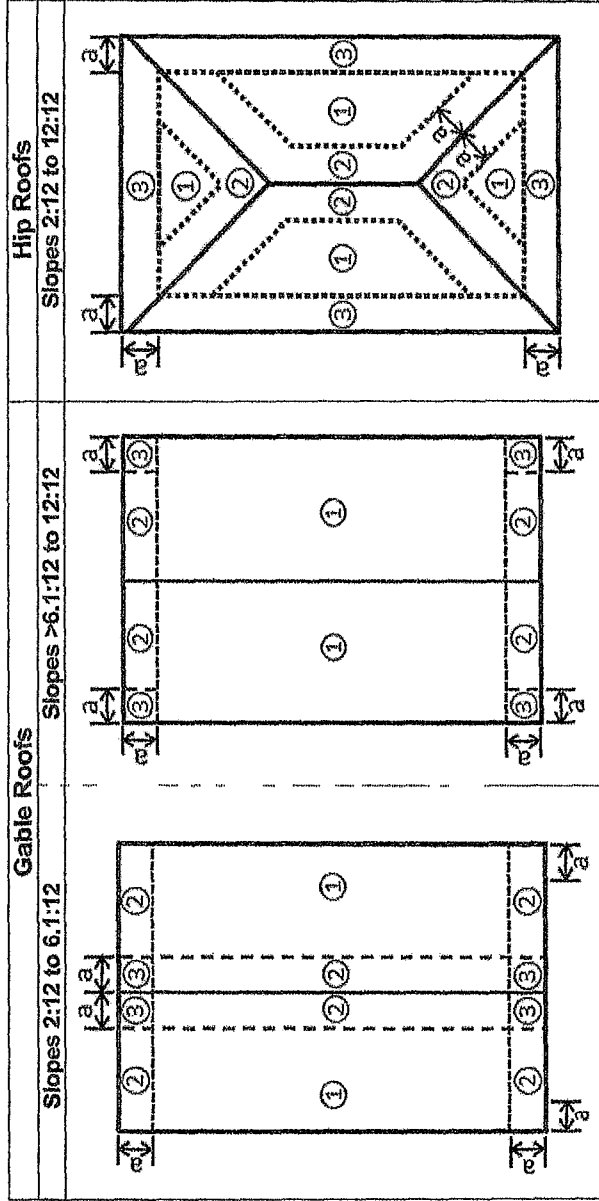

Gable/Hip Roofs in Exposure D (Roof slope between 2:12 and 12:12) Basic Wind Speed (mph)

Building Type	Zone	Mean Roof Height (ft)	Basic Wind Speed (mph)									
			120	130	140	150	160	170	180	190	200	
Partially Open/Enclosed	1	20	44.7	-52.4	-60.8	-69.8	-79.4	-89.7	-100.5	-112.0	-124.1	
		25	-46.4	-54.4	-63.1	-72.4	-82.4	-93.1	-104.3	-116.2	-128.8	
		30	-47.9	-56.2	-65.1	-74.8	-85.1	-96.1	-107.7	-120.0	-132.9	
		40	-50.3	-59.1	-68.5	-78.6	-89.4	-101.0	-113.2	-126.1	-139.8	
		50	-52.3	-61.4	-71.2	-81.7	-93.0	-105.0	-117.7	-131.1	-145.3	
		60	-54.0	-63.4	-73.5	-84.4	-96.0	-108.4	-121.5	-135.3	-150.0	
	2	20	-59.0	-69.3	-80.3	-92.2	-104.9	-118.5	-132.8	-148.0	-163.9	
		25	-61.3	-71.9	-83.4	-95.7	-108.9	-122.9	-137.8	-153.6	-170.1	
		30	-63.2	-74.2	-86.1	-98.8	-112.4	-126.9	-142.3	-158.5	-175.6	
		40	-66.5	-78.0	-90.5	-103.9	-118.2	-133.4	-149.6	-166.6	-184.6	
		50	-69.1	-81.1	-94.1	-108.0	-122.8	-138.7	-155.5	-173.2	-191.9	
		60	-71.3	-83.7	-97.1	-111.4	-126.8	-143.1	-160.5	-178.8	-198.1	
3	20	-77.5	-90.9	-105.4	-121.0	-137.7	-155.5	-174.3	-194.2	-215.2		
	25	-80.4	-94.4	-109.4	-125.6	-142.9	-161.3	-180.9	-201.5	-223.3		
	30	-83.0	-97.4	-112.9	-129.7	-147.5	-166.5	-186.7	-208.0	-230.5		
	40	-87.2	-102.4	-118.7	-136.3	-155.1	-175.1	-196.3	-218.7	-242.3		
	50	-90.7	-106.4	-123.4	-141.7	-161.2	-182.0	-204.1	-227.4	-251.9		
	60	-93.6	-109.9	-127.4	-146.3	-166.4	-187.9	-210.6	-234.7	-260.0		
Partially Enclosed	1	20	-52.3	-61.3	-71.1	-81.7	-92.9	-104.9	-117.6	-131.0	-145.2	
		25	-54.2	-63.7	-73.8	-84.7	-96.4	-108.8	-122.0	-136.0	-150.6	
		30	-56.0	-65.7	-76.2	-87.5	-99.5	-112.3	-126.0	-140.3	-155.5	
		40	-58.9	-69.1	-80.1	-92.0	-104.6	-118.1	-132.4	-147.5	-163.5	
		50	-61.2	-71.8	-83.3	-95.6	-108.8	-122.8	-137.7	-153.4	-169.9	
		60	-63.2	-74.1	-86.0	-98.7	-112.3	-126.7	-142.1	-158.3	-175.4	
	2	20	-66.6	-78.2	-90.7	-104.1	-118.4	-133.7	-149.9	-167.0	-185.0	
		25	-69.1	-81.1	-94.1	-108.0	-122.9	-138.7	-155.5	-173.3	-192.0	
		30	-71.4	-83.7	-97.1	-111.5	-126.8	-143.2	-160.5	-178.9	-198.2	
		40	-75.0	-88.0	-102.1	-117.2	-133.3	-150.5	-168.8	-188.0	-208.4	
		50	-78.0	-91.5	-106.1	-121.8	-138.6	-156.5	-175.4	-195.5	-216.6	
		60	-80.5	-94.5	-109.6	-125.8	-143.1	-161.5	-181.1	-195.5	-223.6	
3	20	-85.0	-99.8	-115.8	-132.9	-151.2	-170.7	-191.4	-213.2	-236.2		
	25	-88.3	-103.6	-120.1	-137.9	-156.9	-177.1	-198.6	-221.3	-245.2		
	30	-91.1	-106.9	-124.0	-142.4	-162.0	-182.8	-205.0	-228.4	-253.1		
	40	-95.8	-112.4	-130.4	-149.7	-170.3	-192.2	-215.5	-240.1	-266.1		
	50	-99.6	-116.9	-135.5	-155.6	-177.0	-199.8	-224.0	-249.6	-276.6		
	60	-102.8	-120.6	-139.9	-160.6	-182.7	-206.3	-231.2	-257.7	-285.5		

END OF REPORT

This evaluation report is provided for State of Florida product approval under Rule 61G20-3. The manufacturer shall notify CREEK Technical Services, LLC of any product changes or quality assurance changes throughout the duration for which this report is valid. This evaluation report does not express nor imply warranty, installation, recommended use, or other product attributes that are not specifically addressed herein.