

Joest 47803 (64)

3121 Fairgate Dr.
Carrollton TX 75007

John E. Scates, Professional Engineer

office (972) 492-9500 | fax (972) 492-0077

August 14, 2019

Janus International
135 Janus International Blvd
Temple, GA 30179



Re: Janus Series 3100/3100-IM Rolling Doors

To Whom It May Concern:

At the request of Janus International, I have reviewed the drawings and tests listed below. The tests were conducted by Underwriters Laboratories according to ANSI/DASMA 108 and 115 test procedures. The pressures listed on the drawings are direct results of these tests or conservative engineering rational analysis from the actual tests, except that no extrapolation of impact pressures were used. I have concluded that the construction shown on these drawings comply with the structural requirements of the 6th Edition (2017) Florida Building Code. I certify that I meet the requirements of "independence" as detailed in Florida Statutes.

Drawings

T1015-RevB	Series 3100/3100-IM Door Assembly,	+40.0 / -40.0 PSF
T1016-Rev-	Series 3100/3100-IM Door Assembly,	+42.5 / -45.0 PSF

Test Report

Test Reports

<u>Drawing</u>	<u>UL Test Report</u>	<u>Test Date</u>
T1015	SV30743-20180723 (14x8)	07-23-2018
T1016	SV30743-20190716 (16x10)	07-16-2019

The test facility was located at:
UL LLC
750 Anthony Trail
Northbrook, IL 60062

The test reports were signed by an authorized representative of UL LLC, and a Florida P.E.

REV	DESCRIPTION	DATE	APPROVAL
A	DRAWING RELEASE Added Table For Non-Impact Wind Load Ratings	8-09-18	CS
B	Revised Changes	7-30-19	SR

HEADROOM REQUIRED	
OPERATING HEIGHT	VERTICAL HEADROOM
THRU 8'-0"	20"
8'-0" THRU 10'-0"	21"
10'-0" THRU 12'-0"	21 1/2"
12'-0" THRU 14'-0"	22"
14'-0" THRU 16'-0"	22"
16'-0" THRU 18'-0"	22"
18'-0" THRU 20'-0"	22"

ALLOWABLE TRANSVERSE DESIGN WIND LOADS NON-IMPACT RATED SERIES 3100 DOORS ONLY (PSF)		
MAX OPENING WIDTH	DESIGN LOAD POSITIVE	DESIGN LOAD NEGATIVE
8'-0"	68.0	68.0
9'-0"	61.0	61.0
10'-0"	55.3	55.3
11'-0"	50.5	50.5
12'-0"	46.4	46.4
13'-0"	42.9	42.9
14'-0"	40.0	40.0
15'-0"	35.6	35.6
16'-0"	32.0	32.0
17'-0"	29.0	29.0
18'-0"	26.4	26.4
19'-0"	24.2	24.2
20'-0"	22.3	22.3

ALLOWABLE TRANSVERSE DESIGN WIND LOADS IMPACT RATED SERIES 3100-IM DOORS ONLY (PSF)		
MAX OPENING WIDTH	DESIGN LOAD POSITIVE	DESIGN LOAD NEGATIVE
14'-0"	20'-0"	40.0
20'-0"	20'-0"	40.0

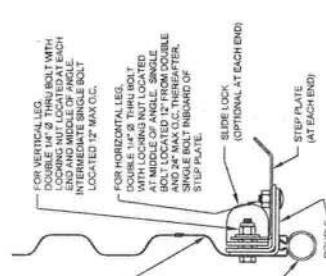
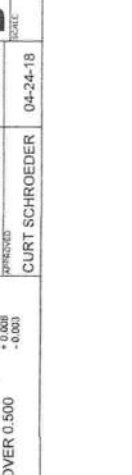
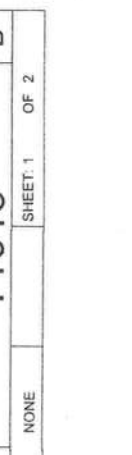
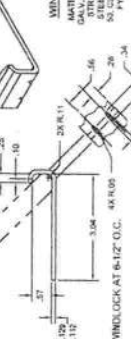
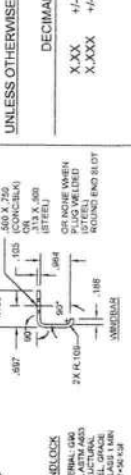
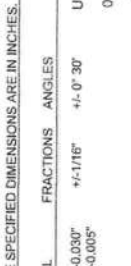
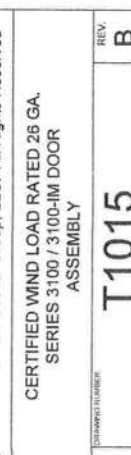
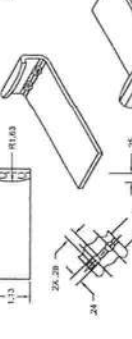
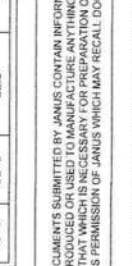
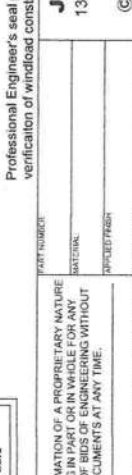
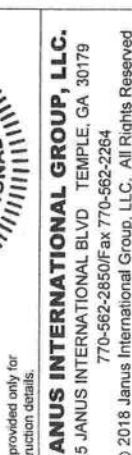
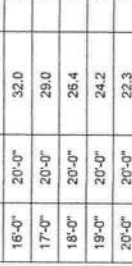
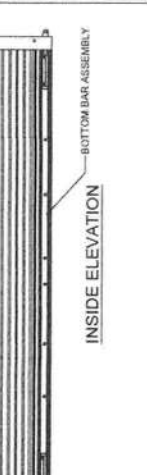
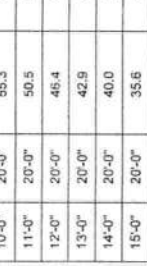
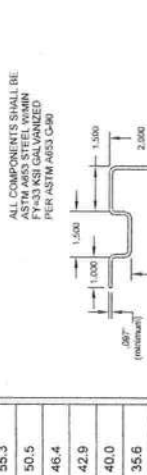
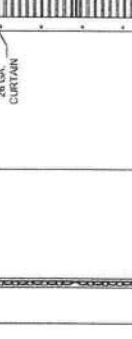
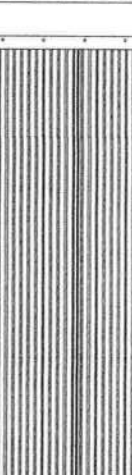
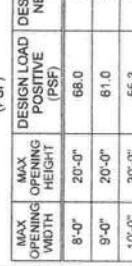
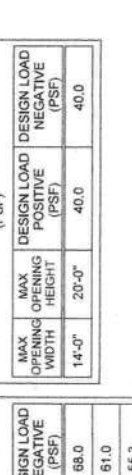
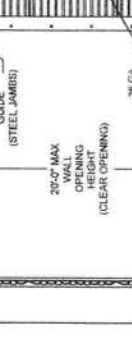
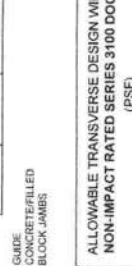
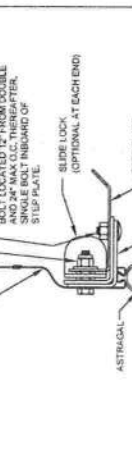
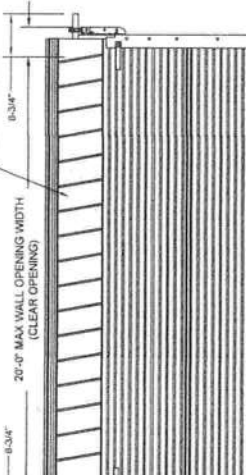
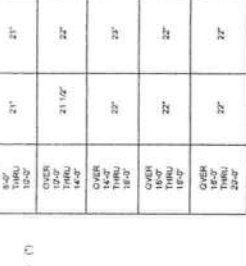
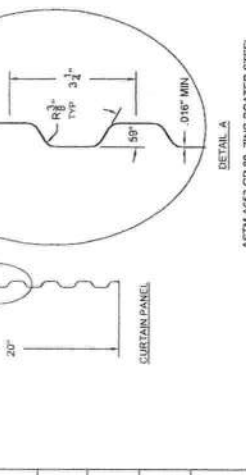
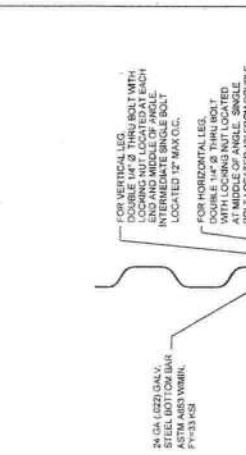
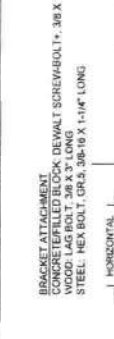

Digitally signed by John E. Scates P.E.
Date: 2019.08.16 12:10:49 -05'00'
John E. Scates, P.E.
2560 King Arthur Blvd, Ste 124-54
Lewisville, TX 75056
FL PE 51737

Professional Engineer's seal provided only for verification of windload construction details.

JANUS INTERNATIONAL GROUP, LLC.
135 JANUS INTERNATIONAL BLVD TEMPLE, GA 30179
770-562-2850/Fax 770-562-2264
© 2018 Janus International Group, LLC. All Rights Reserved

CERTIFIED WIND LOAD RATED 26 GA.
SERIES 3100 / 3100-IM DOOR
ASSEMBLY

REV	DESCRIPTION	DATE	APPROVAL
B	SCOTT ROBILLARD	04-24-18	CS
B	CURT SCHROEDER	04-24-18	SR
B	CURT SCHROEDER	04-24-18	SR

DECIMAL	FRACTIONS	ANGLES	HOLE DIAMETERS
X.XX	+/- 1/16"	+/- 0° 30'	UNDER 0.251
X.XXX	+/- 0.005"		0.251 - 0.500
			OVER 0.500

UNLESS OTHERWISE SPECIFIED DIMENSIONS ARE IN INCHES. TOLERANCES LISTED BELOW.

THESE CONFIDENTIAL DOCUMENTS SUBMITTED BY JANUS CONTAIN INFORMATION OF A PROPRIETARY NATURE AND MAY NOT BE REPRODUCED OR USED TO MANUFACTURE ANYTHING IN PART OR IN WHOLE FOR ANY PURPOSE OTHER THAN THAT WHICH IS NECESSARY FOR PREPARATION OF BIDS OF ENGINEERING WITHOUT THE EXPRESS PERMISSION OF JANUS WHICH MAY RECALL DOCUMENTS AT ANY TIME.

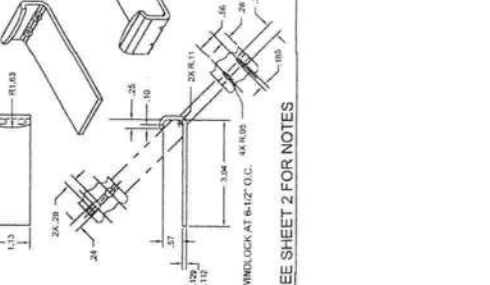
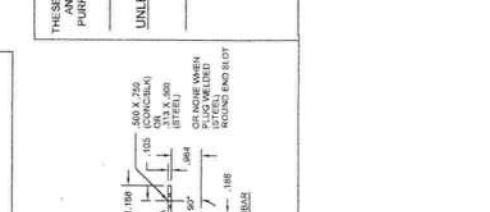

Test Methods

Static Pressure:

The 14x8 door was tested for Static pressure per ANSI/DASMA 108-2012.

The 16x10 door was tested for Static pressure per ANSI/DASMA 108-2017.

All tests were conducted in a manner that was compatible/equivalent to 108-2005, 108-2012 and 108-2017.

Impact and Cycling:

The 14x8 door was tested for Impact and Cycling per ANSI/DASMA 115-2012.

The 16x10 door was tested for Impact and Cycling per ANSI/DASMA 115-2017.

All tests were conducted in a manner that was compatible/equivalent to 115-2005, 115-2012 and 115-2017.

Calculations

The loads applied to the jambs by the door via direct pressure and end-tension catenary forces were computed using industry standard methods. These results are shown as "Vx" and "Vy" on sheet 2 of each drawing.

For locations requiring Impact:

- Doors less than the tested width are allowed, but carry the same psf rating as the tested product.
- Doors wider than tested width (14' for T1015, 16' for T1016) are not approved in locations requiring impact.

For locations *not* requiring Impact:

- Doors other than tested width may have a higher or lower psf rating based on rational analysis using industry-standard calculation methods. The psf rating was determined wherein the end tension, jamb loads, and curtain bending stress are limited to the values computed for the tested width and pressure. A table on the drawing lists these additional widths.

Installation

Anchorage Requirements:

The door drawing includes means to attach the door to the building structure as detailed on Sheet 2. Mounting to steel, concrete, filled-CMU, and wood were all tested.

This Evaluation Report does not address design of the wall/jambs themselves, but provides the anticipated jamb loads that will be generated by this product, Vx and Vy, also illustrated on Sheet 2.

Model Description

This Evaluation is for Series 3100 and 3100-IM Rolling Doors by Janus International.

Series **3100-IM** is **Impact-rated**, wherein no rational analysis was allowed.

Series **3100** is the same construction, but for **non-impact** applications.

All doors consist of a corrugated steel sheet curtain suspended from a drum roller. The curtain is suspended from a drum roller. Coiling around the drum raises the curtain. The sides of the curtain are constrained from lateral movement along their vertical edges by steel guides that are attached to the door jambs. This constraint provides resistance to wind forces. The wind forces are transferred from the curtain to the guides and then through the attachment elements to the door jamb.

Door curtains have a thickness of 26 gage (min. 0.016 in.) and are made of ASTM A653 structural steel, grade 80, pre-painted, galvanized steel with a full coat of primer and baked siliconized polyester finish coat. The corrugated sheets are interlocked mechanically to form the curtain. Lap splices are at approximately 20 inches on center vertically in the installed door. The corrugation height is approximately 5/8 inches and the corrugation pitch is 3.25 inches. Style variations include door width, windlocks, and wind load rating.

Windlocks are attached with three rivets at every other corrugation of the sheet at approximately 6-1/2" spacing.

Limitations

The drawing cited above is an explicit part of this evaluation report. The text of this report does not attempt to address all design details, but relies upon the illustrations and text of these drawings and instructions as well.

Each door should be chosen based on the "psf" requirement determined for a specific installation or locale.

The maximum opening width approved with this report is 16' for IMPACT (Dwg T1016).
The maximum opening width approved with this report is 20' for NON-IMPACT.
The maximum door height for is 20'-0" nominal.

The user of this product is reminded that rolling doors can generate substantial catenary forces at the jambs ("Vx"). The building jambs must be designed to withstand these loads in combinations of Vx with Vy(+), and Vx with Vy(-) shown on sheet 2 of the drawings.

These doors have been tested and evaluated for impact. However, they are not being offered for use in the Florida High Velocity Hurricane Zone (HVHZ).

John E. Scates, P.E.
FL PE #51737

The digitally-signed file is the original. Printed copies are not originals (just as copies of paper-signed documents are not originals).

1-All construction shall comply with Florida Building Code 6th edition 2017.

WIND PRESSURE ON COMPONENTS AND CLADDING

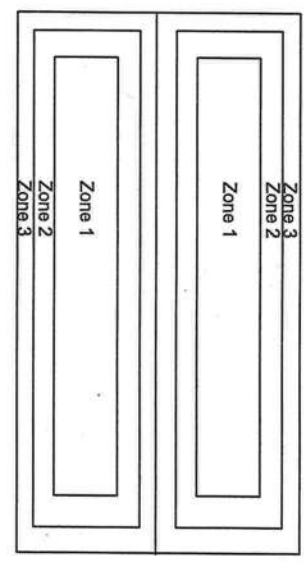

Zone 1 +/- 14.62
 Zone 2 +/- 22.51
 Zone 3 +/- 31.27

PROFESSIONAL SERVICES BY
 DRISCOLL ENGINEERING, INC.
 PO BOX 357577
 GAINESVILLE, FL 32635
 PH (352)-331-1513
 CA 9890

PLANS AND SPECIFICATIONS:
 The plans and specifications presented herein are applicable only for the anticipated construction at the locations shown. If construction plans change, the Design Professional should be notified so the plans and specifications can be re-evaluated. The Design Professional should be given the opportunity to review final plans and specifications to see if the intent of the plans and specifications has been followed and/or if supplemental details and recommendations are needed. The Design Professional warrants that the plans and specifications contained herein, have been prepared in accordance with generally accepted professional engineering practice. No other warranties are implied or expressed.

CORPORATE PROTECTION:
 It is understood and agreed that the Design Professional's Basic Services under this Agreement do not include project observation or review of the Contractor's performance or any other construction phase services, and that such services will be provided by the Client. The Client assumes all responsibility for interpretation of the contractor Documents and for construction observation and supervision and waives any claims against the Design Professional that may be in any way connected thereto.

In addition, the Client agrees, to the fullest extent permitted by law, to indemnify and hold the Design Professional harmless from any loss, claim or cost, including reasonable attorney's fees and costs of defense, arising or resulting from the performance of such services by other person or entities and from any and all claims arising from modifications, clarifications, interpretations, adjustments or changes made to Contract Documents to reflect changed field or other conditions, except for claims arising from the sole negligence or willful misconduct to the Design Professional.

OWNERSHIP OF INSTRUMENTS OF SERVICE:
 All reports, plans, specifications, computer files, field data, notes and other documents and instruments prepared by the Design Professional as instruments of service shall remain the property of the Design Professional. The Design Professional shall retain all common law, statutory and other reserved rights, including the copyright thereto.

DEFECTS IN SERVICE:
 The Client shall promptly report to the Design Professional any defects or suspected defects in the Design Professional's work or services of which the Client becomes aware, so that the Design Professional may take measures to minimize the consequences of such a defect. The Client warrants that he or she will impose a similar notification requirement on all contractors in his or her Client/Contractor contract and shall require all subcontractors at any level to contain a like requirement. Failure by the Client, and the Client's contractors or subcontractors to notify the Design Professional, shall relieve the Design Professional of the costs of remedying the defects above the sum such remedy would have cost had prompt notification been given.

VERIFICATION OF EXISTING CONDITIONS:
 Inasmuch as the remodeling and/or rehabilitation of an existing building requires that certain assumptions be made regarding existing conditions, and because some of these assumptions may not be verifiable without expending additional sums of money or destroying otherwise adequate or serviceable portions of the building, the Client agrees, to the fullest extent permitted by law, to indemnify and hold the Design Professional harmless from any claim, liability or cost (including reasonable attorney's fees and costs of defense) for injury or economic loss arising or allegedly arising out of the professional services provided under this Agreement, excepting only those damages, liabilities, or costs attributable to the sole negligence or willful misconduct of the Design Professional.

ULTIMATE WIND SPEED: 130
 NOMINAL WIND SPEED: 101
 WIND EXPOSURE CATEGORY: B
 RISK CATEGORY 1 NON HABITABLE
 INTERNAL PRESSURE COEFFICIENT Gcpi= +/- 0.018
 DESIGN PRESSURE PER FBC CHAPTER 16, INCLUDING ASCE 7-16 LOAD CALCULATIONS
 ROOF LIVE LOAD = 12.5 PSF
 ROOF DEAD LOAD = 2.5 PSF
 MIN SOIL BEARING 2500 PSF
 TRUSS BEARING LOAD EACH END 5200LB
 TRUSS UPLIFT @ POST 3400LBS

1. Wood framing and fasteners to meet NDS-2012 requirements.
2. Fastener requirements: (1) All nails are Common galvanized; (2) all bolts are to be galvanized steel and include nuts and washers; and (3) all other hardware (Simpson, etc.) is to be installed according to manufacturer's specifications and recommendations. Nailing (size and number) shall satisfy Tables 2306.2.(1), 2306.3.(1) and 2306.3.(#) FBC unless otherwise indicated. Note: Fasteners exposed to the weather are to be treated for weather resistance and compatible with the type of pressure treated wood used (connectors, nails, bolts, nuts and washers).

1. Concrete work shall conform to "Building Code Requirements for Reinforced Concrete" (ACI-318) and "Specifications for Structural Concrete" (ACI-301), Latest Edition.
 2. Concrete mix shall conform to the following specifications. All concrete mixes shall contain a water-reducing admixture conforming to ASTM C-494. Air-entraining admixture shall conform to ASTM C-260.
- CONCRETE MIX A**
- | | |
|---|-----------|
| Ultimate Compressive Strength @ 28 days | 3,000 PSI |
| Slump Range | 4" +/- 1" |
| Maximum Aggregate Size | 1" |
| Entrained Air | None |
| Dry Weight per Cubic Foot | 150 # |

3. Shotcrete mix
4. All concrete shall be cured for a minimum of 28 days. If forms for vertical surfaces are removed prior to the end of the curing period, spray surfaces with liquid membrane curing compound.
5. Reinforcing steel shall conform to ASTM A615, Grade 40 (Fy=40 ksi). Lap continuous bars for tension lap splice per ACI-318, unless otherwise noted. Provide corner bars of same size and spacing as horizontal wall reinforcement. Cover for concrete reinforcing steel shall be in accordance with ACI-318, Paragraph 7.7.
6. Welded wire fabric (WWF) shall conform to ASTM A185. Lap sheets two mesh spaces and wire the adjacent sheets together securely. Cut alternate reinforcement at control joints.
7. All slabs on grade shall have construction or control joints not to exceed 10' - 0" spacing, unless otherwise noted.
8. Electrical conduit and other pipes to be embedded in structural concrete floor slabs or walls shall be placed in accordance with the requirements of ACI-318, Paragraph 6.3.

©2020 DRISCOLL ENGINEERING INC. ALL RIGHTS RESERVED. THESE DRAWINGS ARE THE SOLE OWNERSHIP OF DRISCOLL ENGINEERING INC. ANY REPRODUCTION OF THESE DRAWINGS WITHOUT EXPRESS WRITTEN CONSENT IS FORBIDDEN AND WILL BE PROSECUTED TO THE FULLEST EXTENT OF THE LAW.

80' x 84' PARTIALLY ENCLOSED POLE STORAGE STRUCTURE



JOEST
 3464 SW CR 138
 FT WHITE, FL. DB20-460

DRISCOLL ENGINEERING, INC.
 CONSULTING ENGINEERS
 PO BOX 357577
 GAINESVILLE, FL 32635
 PH (352) 331-1513
 FX (352) 595-3388
 CA 9890

11-9-20
 Michael E Driscoll PE
 FL Reg # 43922

1

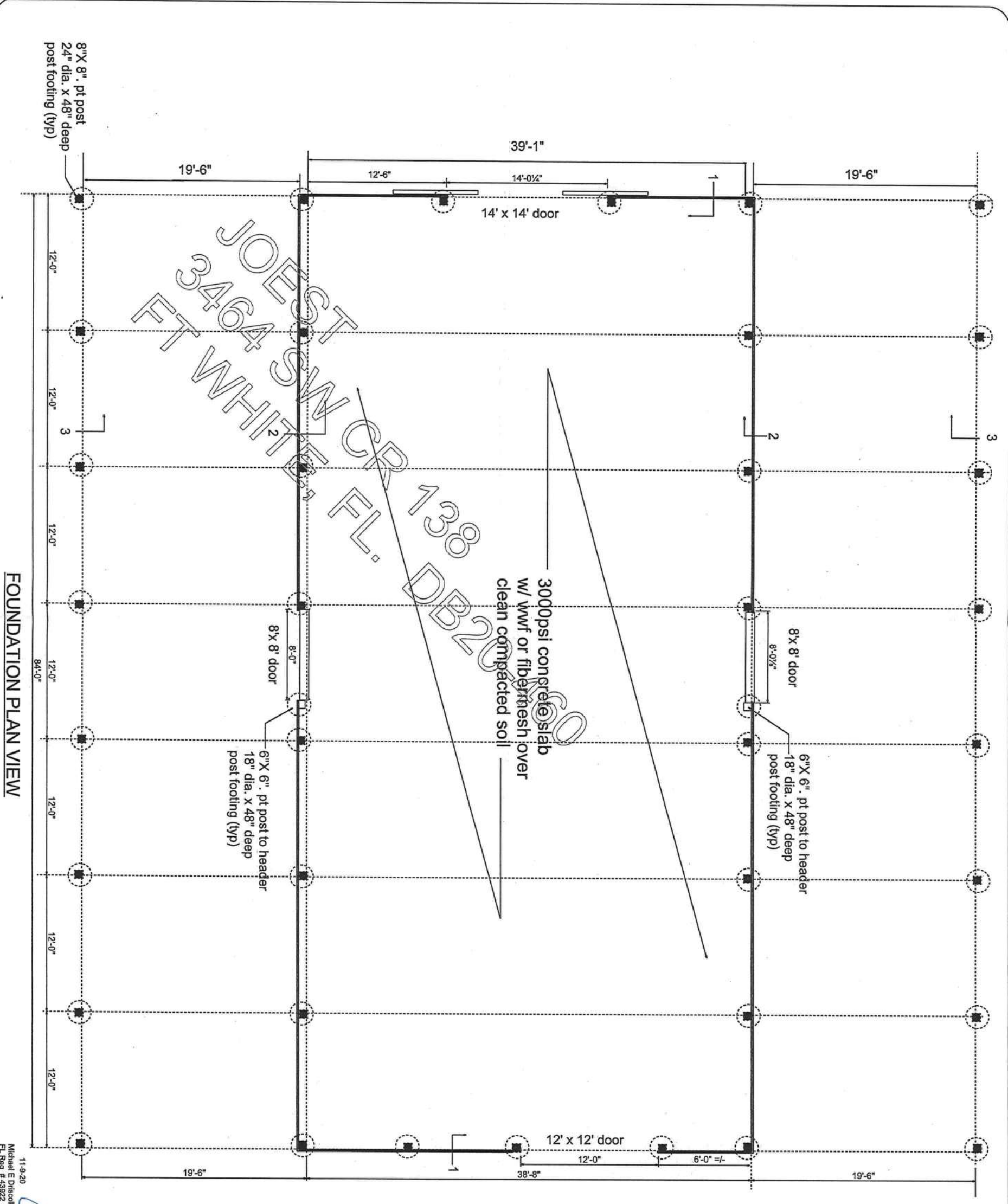

JOEST
 3464 SW CR 138
 FT WHITE, FL. DB20-460

FOUNDATION PLAN VIEW

11-9-20
 Michael E Driscoll PE
 FL Reg # 43922

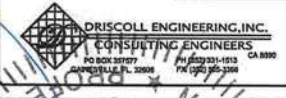

JOEST
 3464 SW CR 138
 FT WHITE, FL. DB20-460

SHEET:
 2

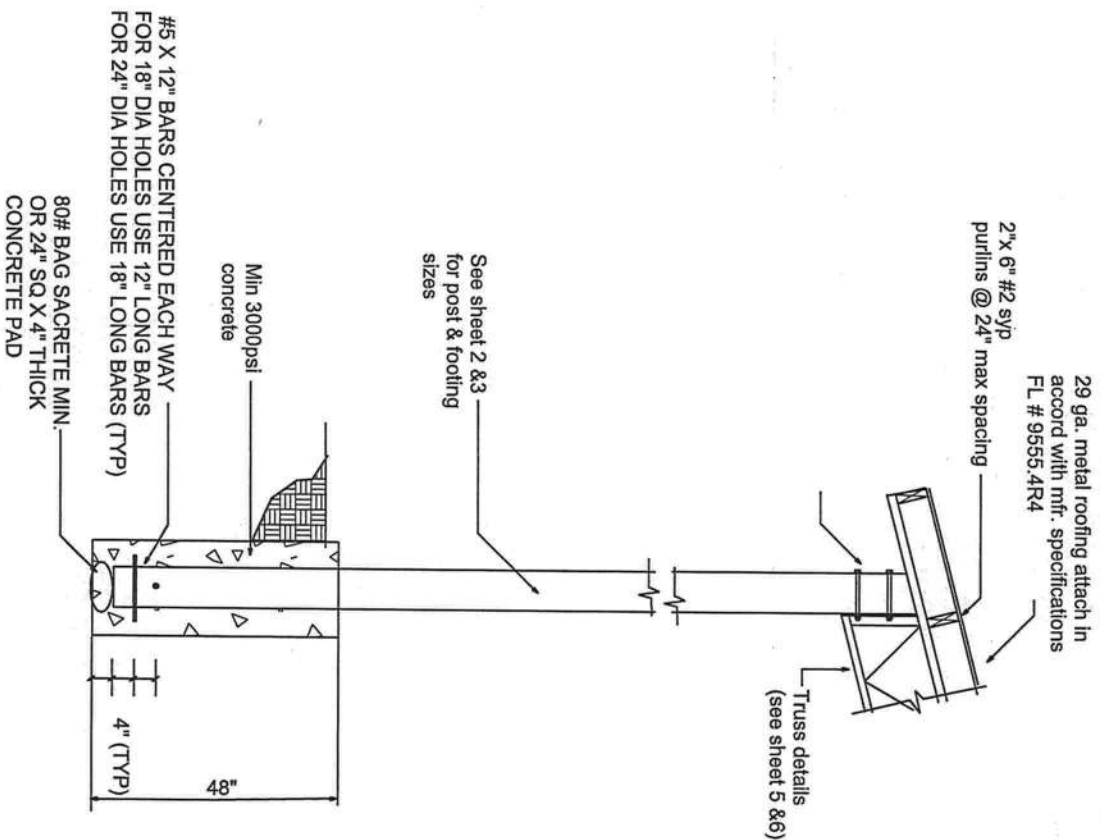

POST FOOTING TO TRUSS DETAIL 3

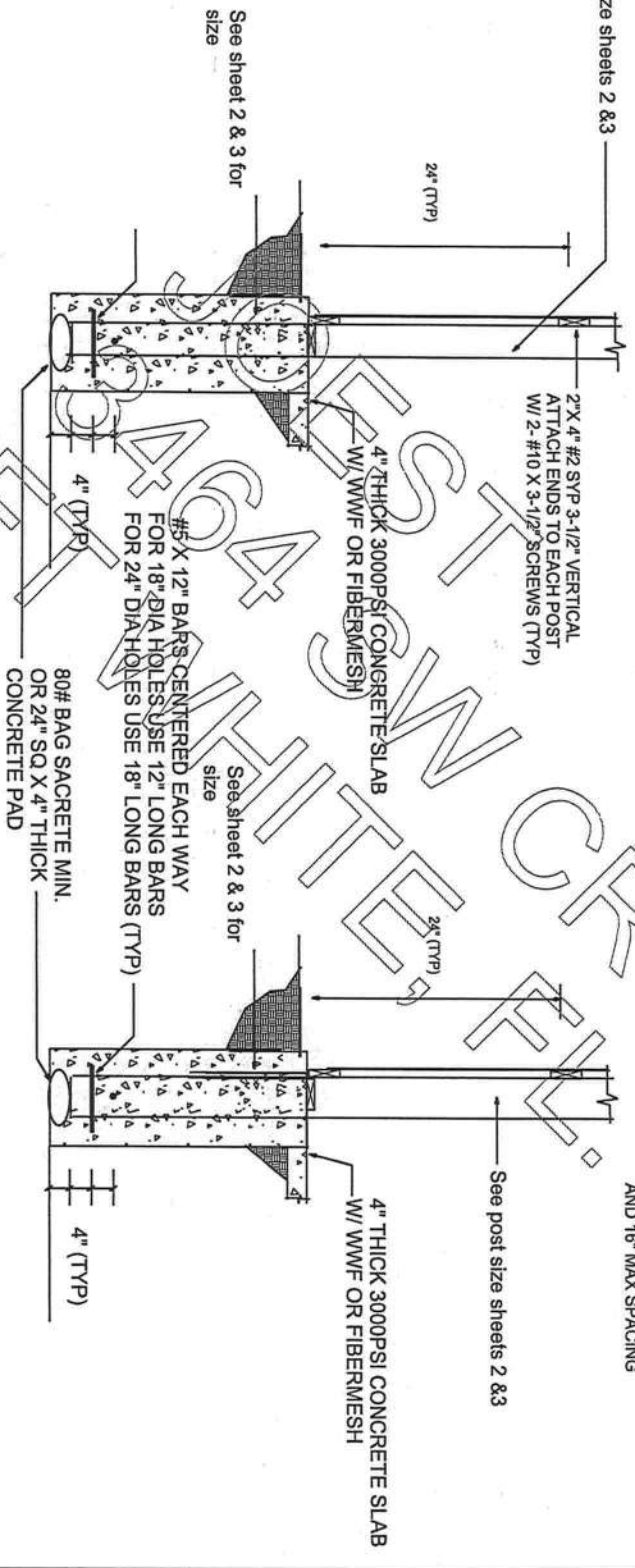
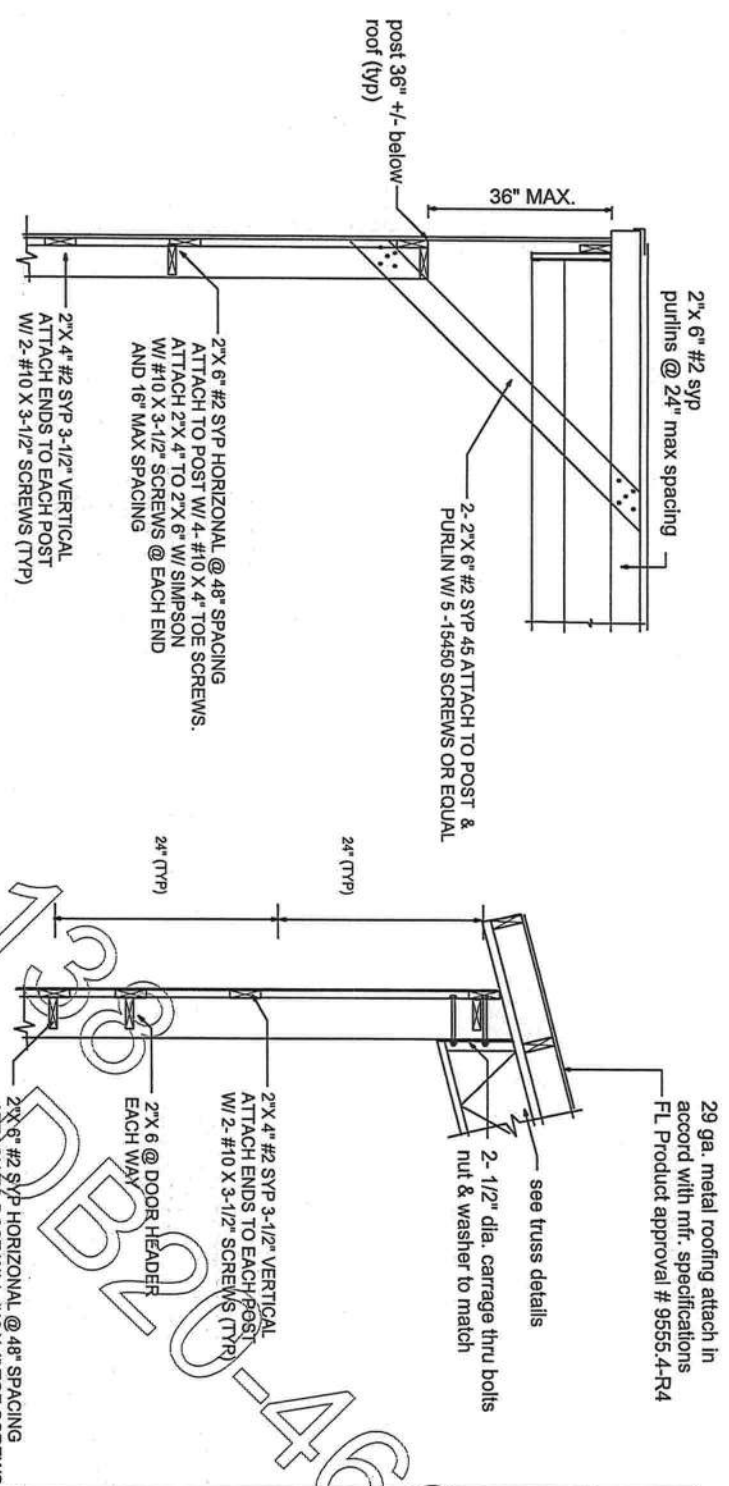

POST FOOTING TO TRUSS DETAIL SECTION 1

POST FOOTING TO TRUSS DETAIL SECTION 2

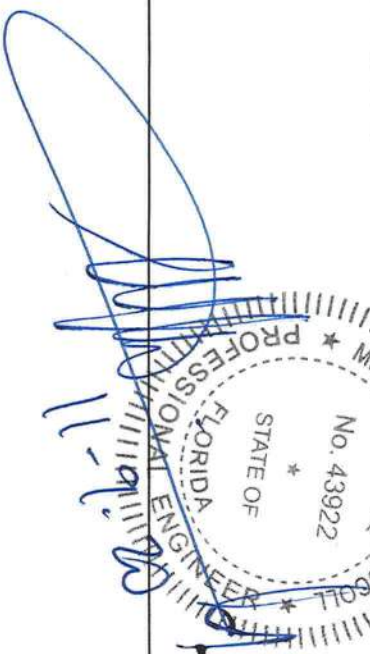

10-21-20
Michael E Driscoll PE
FL Reg # 43922

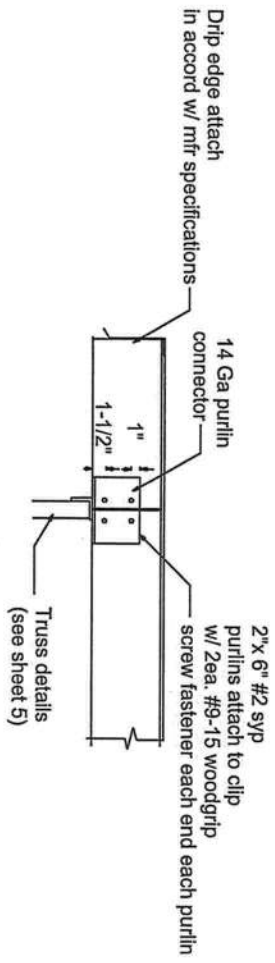

PURLIN CONNECTION DETAIL

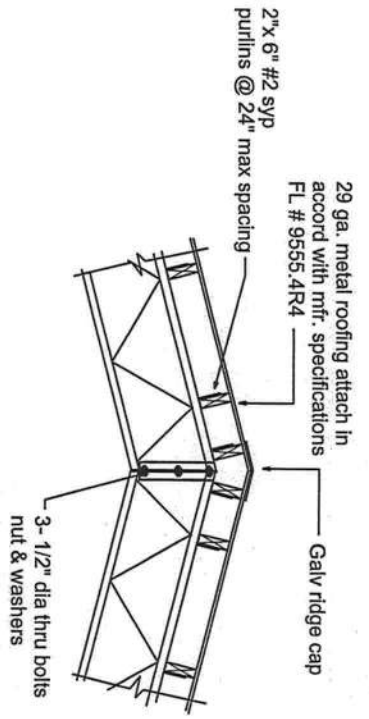

RIDGE CONNECTION DETAIL

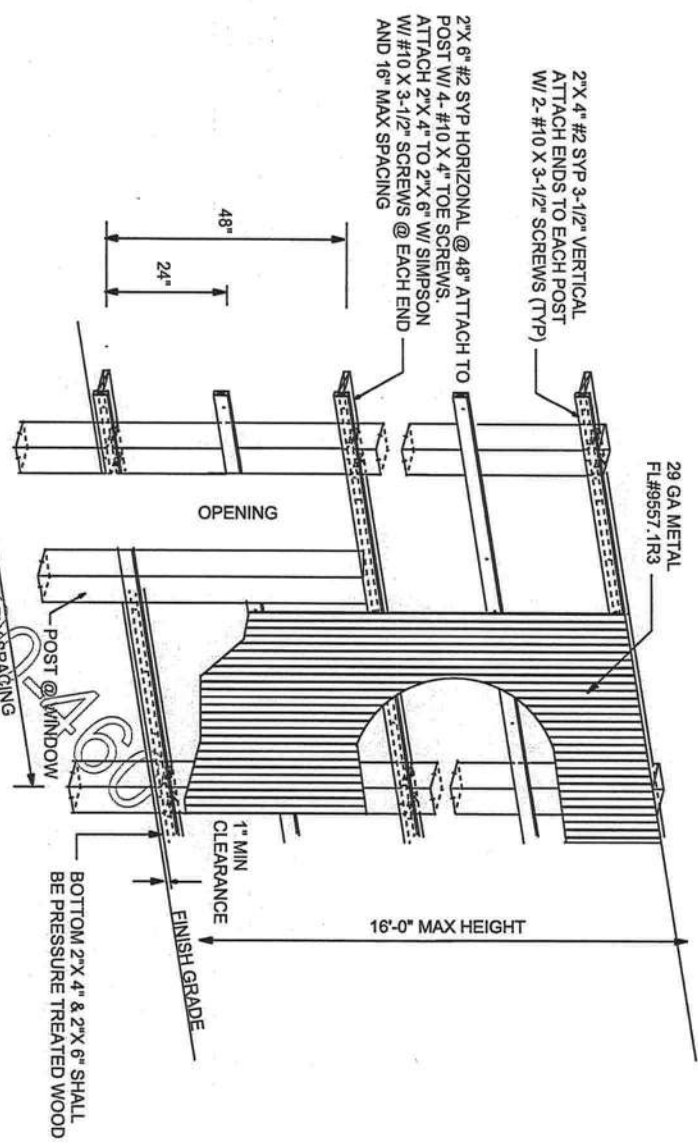

140 MPH SOLID WALL DESIGN.
* USE COATED SCREWS FOR EXTERIOR USE

FRANKLIN SW CR 133 FT WHITE, FL 33434

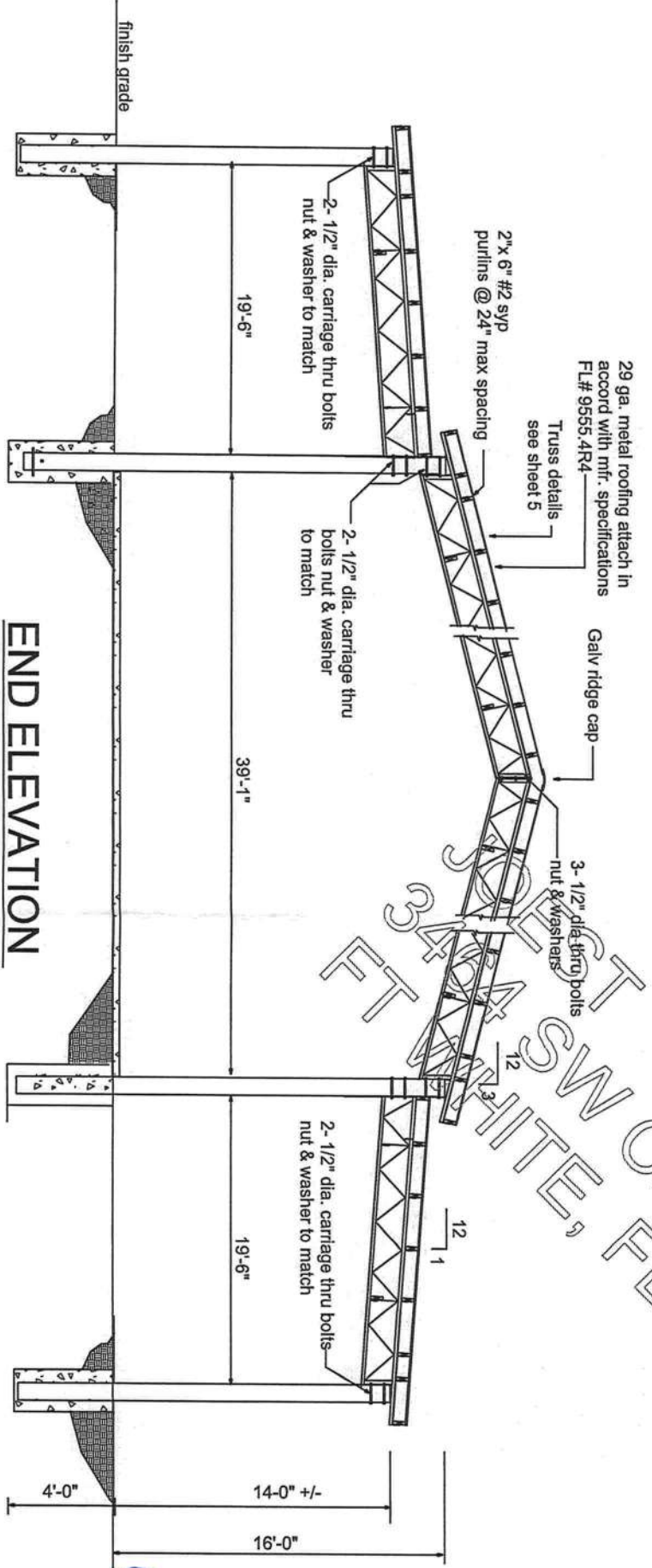

MICHAEL EDWARD DRISCOLL
STATE LICENSE
No. 43922
PROFESSIONAL ENGINEER

11-9-20
Michael E Driscoll PE
FL Reg # 43922

DRISCOLL ENGINEERING, INC.
CONSULTING ENGINEERS
PO BOX 357577 GAINESVILLE, FL 32606
PH (352) 331-1513 CA 8690
FX (352) 505-3366

JOEST
3464 SW CR 138
FT WHITE, FL. DB20-460

SHEET:
5

No.	ELEMENT	MATERIAL (50 KSI)	DESCRIPTION
M1	Collar Tie	ASTM 513	L1-1/2" x 1-1/2" x 3/16"
M2	Collar Tie	ASTM 513	L1-1/2" x 1-1/2" x 3/16"
M3	Top Chord	ASTM 513	L1-1/2" x 1-1/2" x 3/16"
M4	Bottom Chord	ASTM 513	L1-1/2" x 1-1/2" x 3/16"
M5	Center Vertical	ASTM 513	L1-1/2" x 1-1/2" x 3/16"
M6	End Vertical	ASTM 513	L3" x 2" x 3/8"
M7	Bearing angle	ASTM 513	L3" x 2" x 3/8"
M8	Inside vertical	ASTM 513	L1-1/4" x 1-1/4" x 1/8"
M9	Diagonal web	ASTM 513	L1-1/4" x 1-1/4" x 1/8"

STEEL TRUSS CROSS SECTION

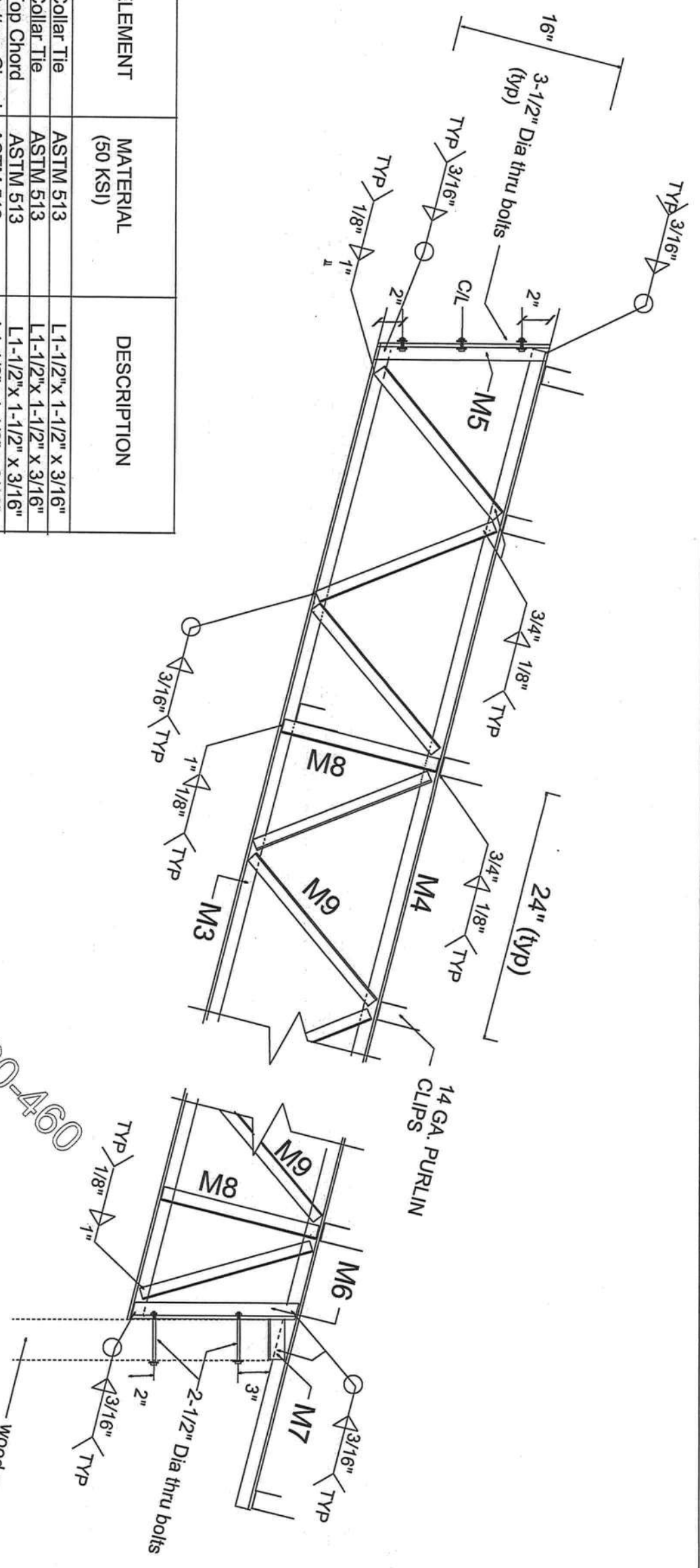

NOTES:

- 1-MATERIALS SHALL CONFORM TO STEEL ASTM 513.
- 2-ALL STEEL SHALL BE 50ksi IN ACCORD WITH CURRENT AISC MANUAL.
- 3-WELDING ELECTRODES TYPE E70XX
- 4-ALL WELDING SHALL BE IN ACCORD WITH CURRENT AWWA REQUIREMENTS.
- 5-ALL WELDING SHALL BE DONE BY A CERTIFIED WELDER.
- 6-BOLTS SHALL BE ASTM A325 w/ NUTS & WASHERS. (TYP)
- 7-WELD STRENGTH 70 KSI MIN.
- 8-ALL POST SHALL BE PRESSURE TREATED GROUND CONTACT.
- 9-PRIMING & PAINTING SHALL BE DONE BY TRUSS MANUFACTURER.
- 10-MIN EDGE DISTANCE FOR BOLTS HOLES SHALL BE 3/4" MIN
- 11-MAX TRUSS SPACING SHALL NOT EXCEED 12'-0"
- 12-THE DESIGNER DISCLAIMS ANY RESPONSIBILITY FOR DAMAGES AS A RESULT OF POOR WORKMANSHIP, OR IMPROPER USE, AND ACCEPTS NO RESPONSIBILITY OR EXERCISES NO CONTROL WITH REGARD TO FABRICATION, HANDLING, AND INSTALLATION OF TRUSSES.

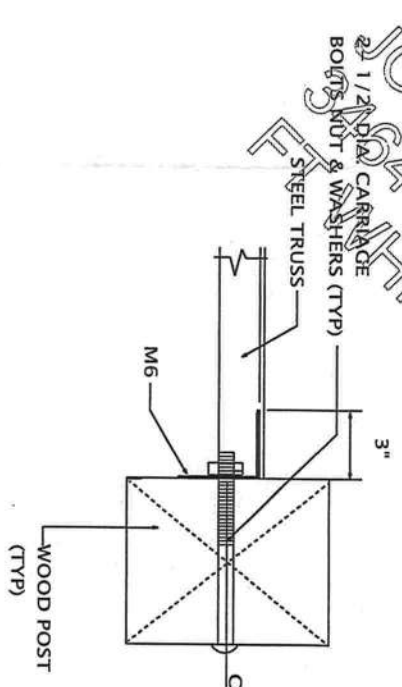

TRUSS DETAILS

CONNECTOR SCHEDULE
 2" x 6" #2 syp purlin to 6" x 6" x 14 ga. clip 2-#9 x 1-1/4" screws
 Truss to ridge 3-1/2" dia thru bolts & nut
 Wood post to truss- 2-1/2" dia thru bolts nut & washers
 Post to concrete 2 1/2" dia x 48" deep w/ 2 #5 bars thru post

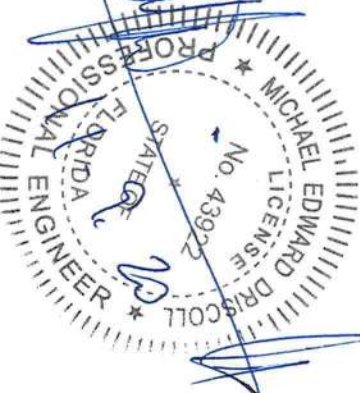

TRUSS TO POST DETAIL
 PLAN VIEW

11-9-20
 Michael E Driscoll PE
 FL Reg # 43922