

# Mobile Home Permit Worksheet

Installer : Kyle Johnson License # IH11266571

Address of home being installed Parcel: 33-4S-16-03265-222

Manufacturer Palm Harbor Length x width 56X28

**NOTE:** if home is a single wide fill out one half of the blocking plan if home is a triple or quad wide sketch in remainder of home  
I understand Lateral Arm Systems cannot be used on any home (new or used) where the sidewall ties exceed 5 ft 4 in.

Installer's initials KJ

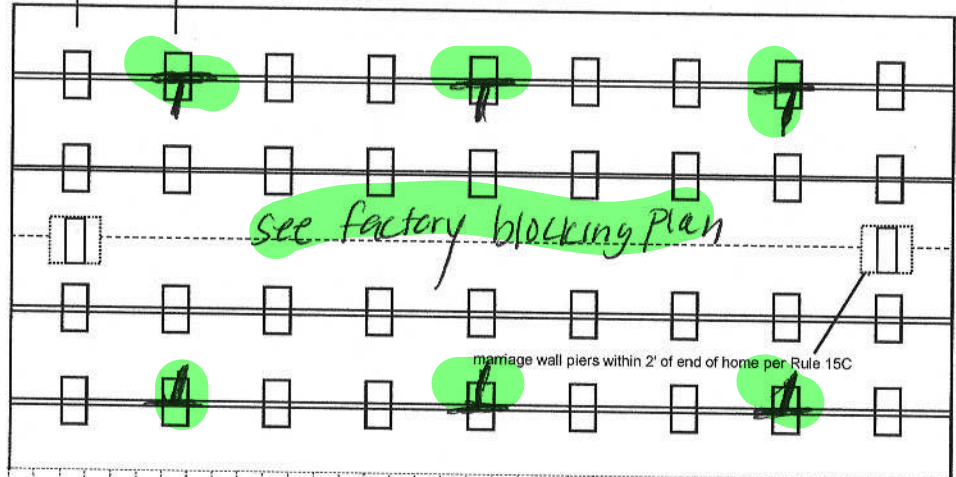
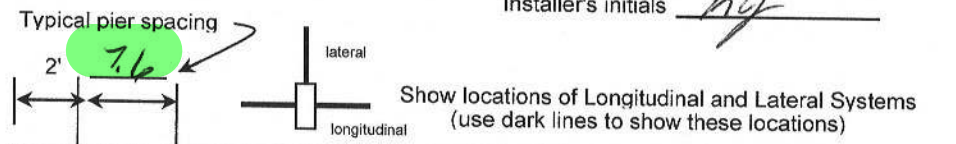

Application Number: \_\_\_\_\_ Date: \_\_\_\_\_

New Home  Used Home

Home installed to the Manufacturer's Installation Manual Home is installed in accordance with Rule 15-C

Single wide  Wind Zone II  Wind Zone III

Double wide  Installation Decal # 108655

Triple/Quad  Serial # PHH340FL23-23291AB

### PIER SPACING TABLE FOR USED HOMES

Load bearing capacity	Footer size (sq in)	16" x 16" (256)	18 1/2" x 18 1/2" (342)	20" x 20" (400)	22" x 22" (484)*	24" X 24" (576)*	26" x 26" (676)
1000 psf	3'	3'	4'	5'	6'	7'	8'
1500 psf	4' 6"	4' 6"	6'	7'	8'	8'	8'
2000 psf	6'	6'	8'	8'	8'	8'	8'
2500 psf	7' 6"	7' 6"	8'	8'	8'	8'	8'
3000 psf	8'	8'	8'	8'	8'	8'	8'
3500 psf	8'	8'	8'	8'	8'	8'	8'

\* interpolated from Rule 15C-1 pier spacing table.

#### PIER PAD SIZES

I-beam pier pad size 17.5x25.5

Perimeter pier pad size 8" 17.5x25.5  
*doors will have Oliver 1055-11 outrigger bar*

Other pier pad sizes (required by the mfg.)

Draw the approximate locations of marriage wall openings 4 foot or greater. Use this symbol to show the piers.

List all marriage wall openings greater than 4 foot and their pier pad sizes below.

Opening	Pier pad size
<u>see factory</u>	
<u>Blocking Plan</u>	

#### TIEDOWN COMPONENTS

**Longitudinal Stabilizing Device (LSD)**  
Manufacturer \_\_\_\_\_

**Longitudinal Stabilizing Device w/ Lateral Arms**  
Manufacturer Oliver 1101V

#### POPULAR PAD SIZES

Pad Size	Sq In
16 x 16	256
16 x 18	288
18.5 x 18.5	342
16 x 22.5	360
17 x 22	374
13 1/4 x 26 1/4	348
20 x 20	400
17 3/16 x 25 3/16	441
17 1/2 x 25 1/2	448
24 x 24	576
26 x 26	676

#### ANCHORS

4 ft  5 ft

#### FRAME TIES

within 2' of end of home spaced at 5' 4" oc

#### OTHER TIES

	Number
Sidewall	<u>34</u>
Longitudinal	<u>0</u>
Marriage wall	<u>12</u>
Shearwall	<u>3</u>

# Mobile Home Permit Worksheet

Application Number: \_\_\_\_\_ Date: \_\_\_\_\_

## POCKET PENETROMETER TEST

The pocket penetrometer tests are rounded down to \_\_\_\_\_ psf or check here to declare 1000 lb. soil  without testing.

x 1000 x \_\_\_\_\_ x 1000

### POCKET PENETROMETER TESTING METHOD

1. Test the perimeter of the home at 6 locations.
2. Take the reading at the depth of the footer.
3. Using 500 lb. increments, take the lowest reading and round down to that increment.

x 1000 x \_\_\_\_\_ x 1000



## TORQUE PROBE TEST

The results of the torque probe test is \_\_\_\_\_ inch pounds or check here if you are declaring 5' anchors without testing \_\_\_\_\_. A test showing 275 inch pounds or less will require 5 foot anchors.

**Note:** A state approved lateral arm system is being used and 4 ft. anchors are allowed at the sidewall locations. I understand 5 ft anchors are required at all centerline tie points where the torque test reading is 275 or less and where the mobile home manufacturer may requires anchors with 4000 lb holding capacity.

[Signature] Installer's initials

### ALL TESTS MUST BE PERFORMED BY A LICENSED INSTALLER

Installer Name Kyle Johnson  
Date Tested Assumed Oliver uses 4 & 5 Anchors together

### Electrical

Connect electrical conductors between multi-wide units, but not to the main power source. This includes the bonding wire between multi-wide units. Pg. \_\_\_\_\_

### Plumbing

Connect all sewer drains to an existing sewer tap or septic tank. Pg. \_\_\_\_\_

Connect all potable water supply piping to an existing water meter, water tap, or other independent water supply systems. Pg. \_\_\_\_\_

### Site Preparation

Debris and organic material removed   
Water drainage: Natural \_\_\_\_\_ Swale \_\_\_\_\_ Pad \_\_\_\_\_ Other

### Fastening multi wide units

Floor: Type Fastener: 1495 Length: 7 Spacing: 20  
Walls: Type Fastener: 1495 Length: 6 Spacing: 18  
Roof: Type Fastener: 1495 Length: 7 Spacing: 20  
For used homes a min 30 gauge, 8" wide, galvanized metal strip will be centered over the peak of the roof and fastened with galv. roofing nails at 2" on center on both sides of the centerline.

### Gasket (weatherproofing requirement)

I understand a properly installed gasket is a requirement of all new and used homes and that condensation, mold, mildew and buckled marriage walls are a result of a poorly installed or no gasket being installed. I understand a strip of tape will not serve as a gasket.

Installer's initials [Signature]

Type gasket factory Installed:  
Pg. of 211 Between Floors Yes \_\_\_\_\_  
Between Walls Yes \_\_\_\_\_  
Bottom of ridgebeam Yes \_\_\_\_\_

### Weatherproofing

The bottomboard will be repaired and/or taped. Yes  Pg. \_\_\_\_\_  
Siding on units is installed to manufacturer's specifications. Yes   
Fireplace chimney installed so as not to allow intrusion of rain water. Yes \_\_\_\_\_

### Miscellaneous

Skirting to be installed. Yes  No \_\_\_\_\_  
Dryer vent installed outside of skirting. Yes  N/A \_\_\_\_\_  
Range downflow vent installed outside of skirting. Yes \_\_\_\_\_ N/A \_\_\_\_\_  
Drain lines supported at 4 foot intervals. Yes \_\_\_\_\_  
Electrical crossovers protected. Yes   
Other: \_\_\_\_\_

**Installer verifies all information given with this permit worksheet is accurate and true based on the manufacturer's installation instructions and or Rule 15C-1 & 2**

Installer Signature [Signature] Date 6/17/24



BLOCKING LOCATIONS SHOWN ARE CONSIDERED TYPICAL. BLOCKS MAY BE MOVED FROM LOCATION SHOWN (WITH THE EXCEPTION OF SHEARWALL OR COLUMN LOCATIONS) AS LONG AS THE MAXIMUM SPACING IS NOT EXCEEDED. UNLESS OTHERWISE SPECIFIED IN THE NOTES BELOW, THE DISTANCE BETWEEN ANY ADJACENT PIERS MAY DEViate FROM THE LISTED SPACING BY 10%, SO LONG AS THE OVERALL AVERAGE DISTANCE BETWEEN PIERS IS EQUAL TO OR LESS THAN THE LISTED SPACING. SEE SECTION 3 IN THE PALM HARBOR HOMES INSTALLATION MANUAL FOR MORE SPECIFICS ON BLOCKING THE HOME.

**COLUMN LOADS**

- ① = 1634 LBS.
- ② = 1634 LBS.
- ③ = 3600 LBS.
- ④ = 3600 LBS.

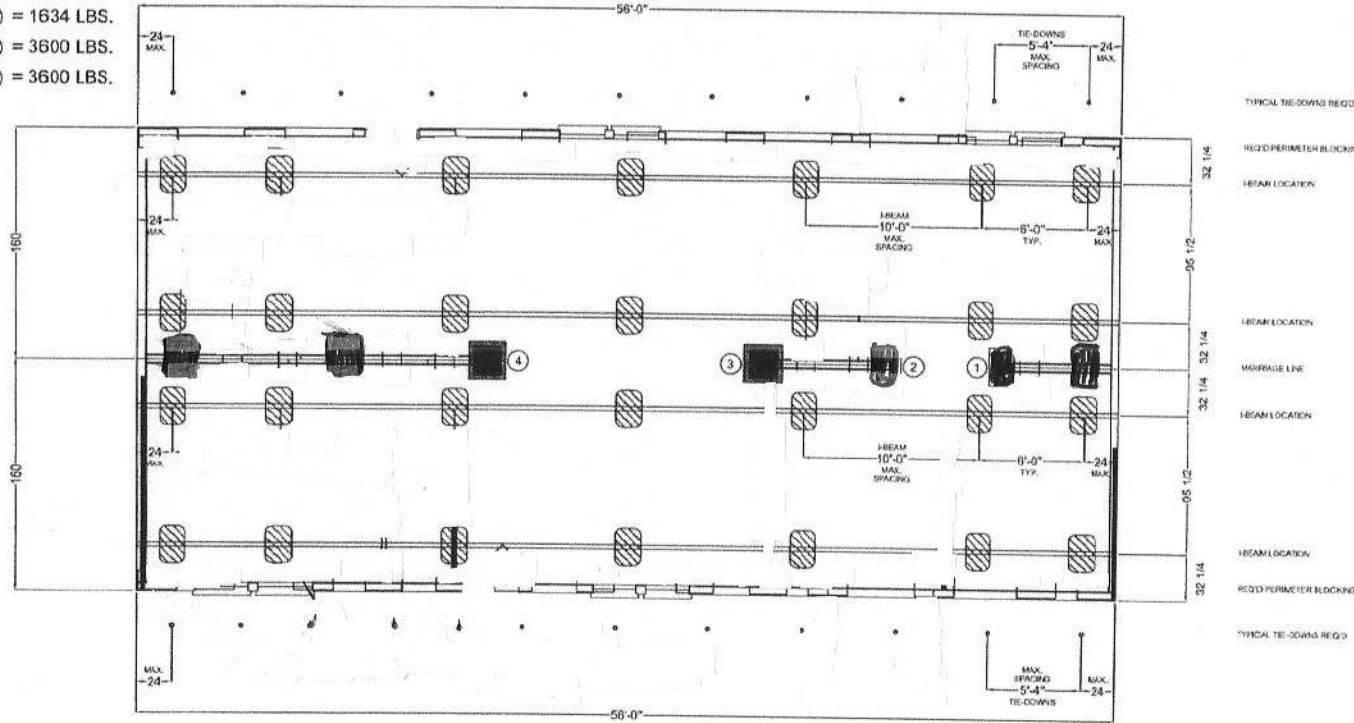

NOTE: PERIMETER BLOCKING IS NOT REQUIRED AT THE SIDEWALLS ON MODULES 12'-0" AND LESS IN WIDTH

INSTALLING A HOME CAN BE VERY DANGEROUS. ONLY QUALIFIED PERSONNEL SHOULD EVER ATTEMPT TO INSTALL A HOME.

**NOTES:**

1. BLOCKING SPACING BASED ON 20PSF LIVE LOAD ON ROOF AND 1000 PSF SOIL BEARING CAPACITY.
2. CONCRETE BLOCKS ARE ONLY RATED AT 8000 POUNDS, 8000 POUND PIERS OR HIGHER MUST BE DOUBLE BLOCKED.
3. BLOCKING REQUIRED AT OPENING LESS THAN 48" IN WIDTH ONLY TO MAKE NON-OPERATIONAL DOORS OPERATIONAL. PERIMETER SUPPORTS ARE REQUIRED ON EACH SIDE OF ALL OPENINGS GREATER THAN 48" (IE, SLIDING GLASS DOORS, BOX BAY WINDOWS, RECESSED ENTRIES, ETC...) REFER TO THE INSTALLATION MANUAL FOR MORE SPECIFICS.
4. MARRIAGE LINE BLOCKING ONLY REQUIRED UNDER WALL MARRIAGE LINE WALL AREAS.
5. FOR WIND ZONE II AND III INSTALLATIONS, A PIER IS REQUIRED UNDER THE "SHEARWALLS" WHERE THEY ATTACH TO THE SIDEWALL. THESE SHEARWALLS ARE INDICATED AS DARKENED-IN WALLS ON THE FLOOR PLAN.
6. ABS PIER PAD SIZES AND CAPACITIES BASED ON INFORMATION PROVIDED BY "MANUFACTURED HOUSING FOUNDATION SYSTEMS".

7. STABILIZER SYSTEM PER PALM HARBOR INSTALLATION MANUAL, AND ALL SIDEWALL ANCHORS ARE SPACED AT 5'-4" MAXIMUM. FOUR FOOT GROUND ANCHOR MAY BE USED EXCEPT WHERE PALM HARBOR INSTALLATION MANUAL SPECIFIES DIFFERENT.
8. IT IS THE RESPONSIBILITY OF THE DEALER AND/OR INSTALLER TO CERTIFY THAT ANY BLOCKING AND/OR FOUNDATION PRINT(S), OR ANY OTHER DIAGRAM SUPPLIED FOR ANY SITE INSTALLATION CORRELATE WITH THE UNIT ORDERED AND BEING SET AS WELL AS THE CONDITIONS OF THE SITE. THE MANUFACTURER WILL NOT BE LIABLE FOR DAMAGES ARISING FROM FAILURE OF THE DEALER AND/OR INSTALLER TO MAKE CERTAIN THAT THE CONTRACTOR/INSTALLER HAS THE CORRECT DIAGRAMS, REGARDLESS OF WHAT WAS SUPPLIED BY THE MANUFACTURER. THE MANUFACTURER ASSUMES NO RESPONSIBILITY OR LIABILITY FOR THE DESIGN OF THE BLOCKING AND/OR FOUNDATION.
9. FOR MORE SPECIFIC INFORMATION REFER TO THE INSTALLATION MANUAL.
10. ALL SETUP MUST COMPLY WITH THE PALM HARBOR HOMES INSTALLATION MANUAL.

SEE NOTE SECTION

16"X16"X4" CONCRETE PIER PADS - STACKED  
LOAD CAPACITY = # OF PADS ON BOTTOM X 1490 LBS.

17.5"X25.5" ABS PAD = 3000 LBS. CAPACITY

17.5"X25.5" ABS PAD = 2375 LBS. CAPACITY

20"X20" ABS PAD  
13"X26" ABS PAD  
PAD ASSEMBLY  
MAX. LOAD = 4800 LBS.  
SINGLE STACK BLOCKS

17.5"X25.5" ABS PAD  
17.5"X25.5" ABS PAD  
PAD ASSEMBLY  
MAX. LOAD = 6000 LBS.  
SINGLE STACK BLOCKS

13"X26" ABS PAD  
PAD ASSEMBLY  
MAX. LOAD = 4800 LBS.  
SINGLE STACK BLOCKS

17.5"X25.5" ABS PAD

**LEGEND**

STABILIZER SYSTEM REQUIRED PER PALM HARBOR HOMES INSTALLATION MANUAL

Model Number: 340LD28563A  
Serial Number: NA

IT IS THE RESPONSIBILITY OF THE DEALER AND/OR INSTALLER TO CERTIFY THAT ANY BLOCKING AND/OR FOUNDATION PRINT(S) ARE SUITABLE FOR THE SPECIFIC INSTALLATION SITE.

HOME LOCATION

PARK: \_\_\_\_\_  
STREET: \_\_\_\_\_  
CITY: \_\_\_\_\_

DRAWING INFORMATION

NAME: \_\_\_\_\_ MO  
DATE: 06/16/22  
SCALE: NOT PRINTED TO SCALE

H.U.D. WINDZONE  
**2/3**

SETUP INFORMATION  
BLOCKING DIAGRAM

DESIGNED FOR 20  
PSF FLOOR LIVE LOAD  
AND 1000 PSF SOIL  
BEARING CAPACITY

**BLK-1**  
SHEET 1 OF 1

License Number: IH / 1126657 / 1 Name: KYLE JOHNSON

Order #: 6127	Label #: 108055	Manufacturer:	(Check Size of Home)
Homeowner:		Year Model:	Single _____
Address:		Length & Width:	Double _____
City/State/Zip:		Type Longitudinal System:	Triple _____
Phone #:		Type Lateral Arm System:	HUD Label #:
Date Installed:		New Home: _____ Used Home: _____	Soil Bearing / PSF:
Installed Wind Zone:		Data Plate Wind Zone:	Torque Probe / in-lbs:
Note:			Permit #:



**STATE OF FLORIDA  
INSTALLATION CERTIFICATION LABEL**

108055

LABEL #	DATE OF INSTALLATION
KYLE JOHNSON	
NAME	
IH / 1126657 / 1	6127
LICENSE #	ORDER #

CERTIFIES THAT THE INSTALLATION OF THIS MOBILE HOME IS IN ACCORDANCE WITH FLORIDA STATUTES 320.8249, 320.8325 AND RULES OF THE HIGHWAY SAFETY AND MOTOR VEHICLES.

**INSTRUCTIONS**

PLEASE WRITE DATE OF INSTALLATION AND AFFIX LABEL NEXT TO HUD LABEL. USE PERMANENT INK PEN OR MARKER ONLY. COMPLETE INFORMATION ABOVE AND KEEP ON FILE FOR A MINIMUM OF 2 YEARS. YOU ARE REQUIRED TO PROVIDE COPIES WHEN REQUESTED.

**OLIVER**

*Technologies, Inc.*

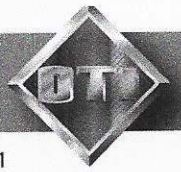

467 Swan Ave • Hohenwald, TN 38462 • (800) 284-7437 • [www.olivertechnologies.com](http://www.olivertechnologies.com) • Fax (931) 796-8811

**OLIVER TECHNOLOGIES, INC.  
INSTALLATION INSTRUCTIONS FOR FLORIDA  
MODEL 1101 "V" SERIES ALL STEEL FOUNDATION SYSTEM PAN & CONCRETE (revision 5/18)  
PATENT# 6634150 & OTHER PATENT PENDING**

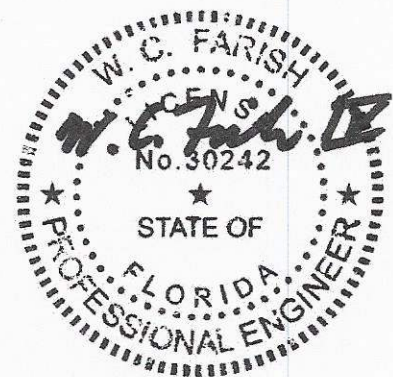

Aug 24, 2018

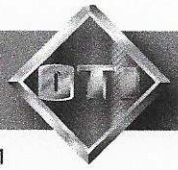

**OLIVER TECHNOLOGIES, INC.  
FLORIDA INSTALLATION INSTRUCTIONS FOR THE  
MODEL 1101 "V" SERIES ALL STEEL FOUNDATION SYSTEM**

**MODEL 1101 "V" (Steps 1-14)  
LONGITUDINAL ONLY: Follow Steps 1-9  
LATERAL ONLY: Follow Steps 1-3 and Steps 10-14  
FOR CONCRETE APPLICATIONS: Follow Steps 15-18**

ENGINEERS STAMP

ENGINEERS STAMP

**1. SPECIAL CIRCUMSTANCES:** If the following conditions occur - **STOP! Contact Oliver Technologies at 1-800-284-7437 :**

- a) Pier height exceeds 48"
- b) length of home exceeds 76'
- c) Roof eaves exceed 16"
- d) Sidewall height exceed 96"
- e) Location is within 1500 feet of coast

**INSTALLATION OF GROUND PAN**

2. Remove weeds and debris in an approximate two foot square to expose firm soil for each ground pan (C) .
3. Place ground pan (C) directly below chassis I-beam. Press or drive pan firmly into soil until flush or below soil then install pier per manufacturer's instructions or per Florida Regs.  
**SPECIAL NOTE:** The longitudinal "V" brace system may also serve as a pier under the home and should be loaded as any other pier. It is recommended that after leveling piers, and one-third inch (1/3") before home is lowered completely on to piers, complete steps 4 through 9 below then remove jacks.

**INSTALLATION OF LONGITUDINAL "V" BRACE SYSTEM (Model 1101 L "V")**

**NOTE:** WHEN INSTALLING THE LONGITUDINAL SYSTEM ONLY, A MINIMUM OF 2 SYSTEMS PER FLOOR SECTION IS REQUIRED. SOIL TEST PROBE SHOULD BE USED TO DETERMINE CORRECT TYPE OF ANCHOR PER SOIL CLASSIFICATION. IF PROBE TEST READINGS ARE BETWEEN 175 & 275 A 5 FOOT ANCHOR MUST BE USED. IF PROBE TEST READINGS ARE BETWEEN 276 & 350 A 4 FOOT ANCHOR MAY BE USED. USE GROUND ANCHORS WITH DIAGONAL TIES AND STABILIZER PLATES EVERY 5'4" . VERTICAL TIES ARE ALSO REQUIRED ON HOMES SUPPLIED WITH VERTICAL TIE CONNECTION POINTS (PER FLORIDA REG.).

4. Choose one of the approved longitudinal tube installations; either Diagram A or B. Then select the correct square tube (E) length from the diagram for appropriate pier height at support location or cut and drill 1.5" square tube to achieve appropriate length.

PIER HEIGHT (40° Min. - 45° Max.)	1.25" Tube Length	1.50" Tube Length
7 3/4" to 25"	22"	18"
24 3/4" to 32 1/4"	32"	18"
33" to 41"	44"	18"
40" to 48"	54"	18"

Diagram A

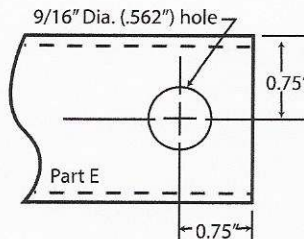

PIER HEIGHT (40° Min. - 60° Max.)	1.50" Tube Length
14" to 18"	20"
18" to 25"	28"
24" to 35"	39"
30" to 40"	44"
36" to 48"	54"

Diagram B

5. Install (2) of the 1.50" square tubes (E) into the "U" bracket (J), insert carriage bolt and leave nut loose for final adjustment.
6. Place I-beam connector (F) loosely on the bottom flange of the I-beam.
7. (For Diagram A installation) Slide the selected 1.25" tube (E) into a 1.50" tube (E) and attach to I-beam connectors (F) and fasten loosely with bolt and nut. (For Diagram B installation) Attach the selected 1.5" tubes (E) to the I-beam connectors (F) and fasten loosely with bolts and nuts.
8. Repeat steps 6 through 7 to create the "V" pattern of the square tubes loosely in place.
9. Using standard hand tools tighten all nuts and bolts. (For Diagram A installation only, secure 1.25" and 1.50" tubes using four (4) 1/4"-14 x 3/4" self-tapping screws in pre-drilled holes.)

**INSTALLATION OF LATERAL TELESCOPING TRANSVERSE ARM SYSTEM (Model 1101 T "V")**

THE MODEL 1101 "V" (LONGITUDINAL & LATERAL PROTECTION) ELIMINATES THE NEED FOR STABILIZER PLATES & FRAME TIES.

**NOTE:** THE USE OF THIS SYSTEM REQUIRES VERTICAL TIES SPACED AT 5'4".

FOUR FOOT (4') GROUND ANCHOR MAY BE USED EXCEPT WHERE THE HOME MANUFACTURER SPECIFIES DIFFERENT.

10. Install remaining vertical tie-down straps and 4' ground anchors per home manufacturer's instructions. NOTE: Centerline anchors to be sized according to soil torque condition. Any manufacturer's specifications for sidewall anchor loads in excess of 4,000 lbs. require a 5' anchor per Florida Code.
11. Select the correct square tube brace (H) length for set-up lateral transverse at support location. The lengths come in either 60" or 72" lengths. (With the 1.50" tube as the bottom tube, and the 1.25" tube as the inserted tube.)
12. Install the 1.50 transverse brace (H) to the ground pan connector (D) with bolt and nut.
13. Slide 1.25" transverse brace into the 1.50" brace and attach to adjacent I-beam connector (I) with bolt and nut.
14. Secure 1.50" transverse arm to 1.25" transverse arm using four (4) 1/4" - 14 x 3/4" self-tapping screws in pre-drilled holes.

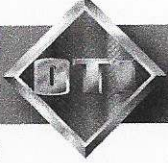

### INSTALLATION USING CONCRETE RUNNER/ FOOTER

15. A concrete runner, footer or slab may be used in place of the steel ground pan.
  - a) The concrete shall be minimum 2500 psi mix
  - b) A concrete runner may be either longitudinal or transverse, and must be a minimum of 8" deep with a minimum width of 16 inches longitudinally or 18 inches transverse to allow proper distance between the concrete bolt and the edge of the concrete (see below).
  - c) Footers must have minimum surface area of 441 sq. in. (i.e. 21" square), and must be a minimum of 8" deep.
  - d) If a full slab is used, the depth must be a 4" minimum. Special inspection of the system bracket installation is not required. Footers must allow for at least 4" from the concrete bolt to the edge of the concrete.

**NOTE:** The bottom of all footings, pads, slabs and runners must be per local jurisdiction.



#### LONGITUDINAL: (Model 1101 LC "V")

16. When using Part# 1101-W-CPCA (wetset) simply install the bracket in runner/footer **OR** When installing in cured concrete use Part# 101-D-CPCA (dryset). The 1101 (dryset) CA bracket is attached to the concrete using (2) 5/8"x3" concrete wedge bolts (Simpson part # S162300H 5/8" X 3" or Powers equivalent). Place the CA bracket in desired location. Mark bolt hole locations, then using a 5/8" diameter masonry bit, drill a hole to a minimum depth of 3". Make sure all dust and concrete is blown out of the holes. Place wedge bolts into drill holes, then place 1101 (dry set) CA bracket onto wedge bolts and start wedge bolt nuts. Take a hammer and lightly drive the wedge bolt down by hitting the nut (making sure not to hit the top of threads on bolt). The sleeve of concrete wedge bolt needs to be at or below the top of concrete. Complete by tightening nuts.

#### LATERAL: (Model 1101 TC "V")

17. For wet set (part # 1101-W-TACA) installation simply install the anchor bolt into runner/footer. For dry set installation (part # 1101-D-TAC) mark bolt hole locations, then using a 5/8" diam. masonry bit, drill a hole to a minimum depth of 3". Make sure all dust and concrete is blown out of the hole. Place wedge bolts (Simpson part #S162300H 5/8" X 3" or Powers equivalent) into (D) concrete dry transverse connector and into drilled hole. If needed, take a hammer and lightly drive the wedge bolts down by hitting the nut (making sure not to hit the top of threads on bolt), then remove the nut. The sleeve of concrete wedge bolt needs to be at or below the top of concrete.
18. When using part# 1101 CVW (wetset) or 1101 CVD (dryset), install per steps 17 & 18.

**Notes:**

1. LENGTH OF HOUSE IS THE ACTUAL BOX SIZE
2.  = LOCATION OF TRANSVERSE BRACING ONLY
3.  = LOCATION OF LONGITUDINAL BRACING ONLY
4.  = TRANSVERSE AND LONGITUDINAL LOCATIONS

ALL WIDTHS AND LENGTHS UP TO 52'

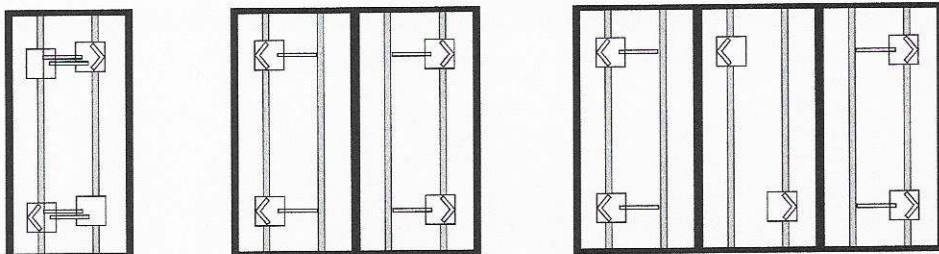

ALL WIDTHS AND LENGTHS OVER 52' TO 80"

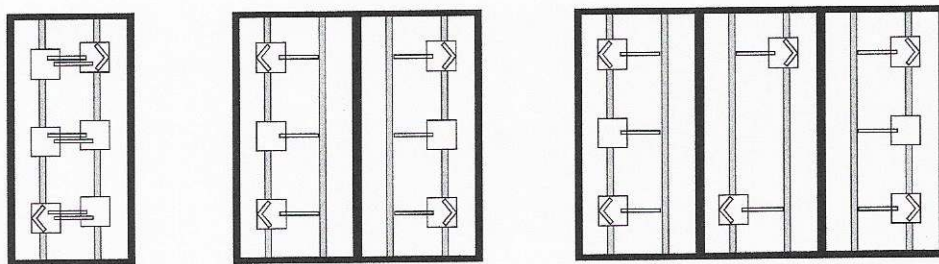

HOMES WITH 5/12 ROOF PITCH REQUIRE: PER FLORIDA REGULATIONS  
6 systems for home lengths up to 52' and 8 systems for homes over 52' and up 80'

PATENT# 6634150 & OTHER PATENT PENDING

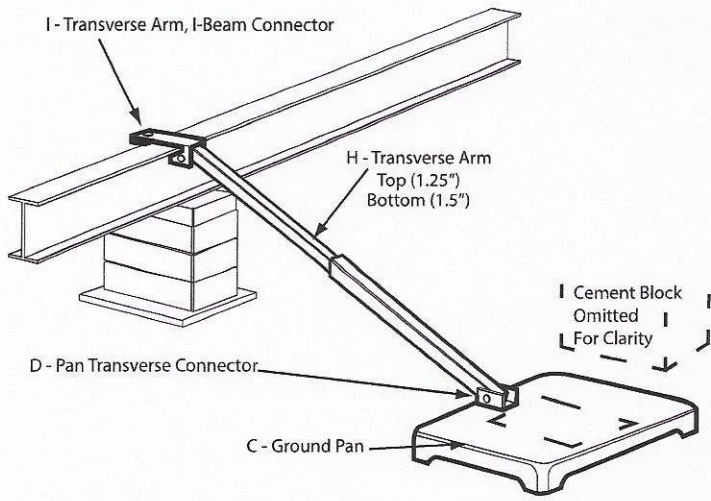

**Model # 1101 T "V"**

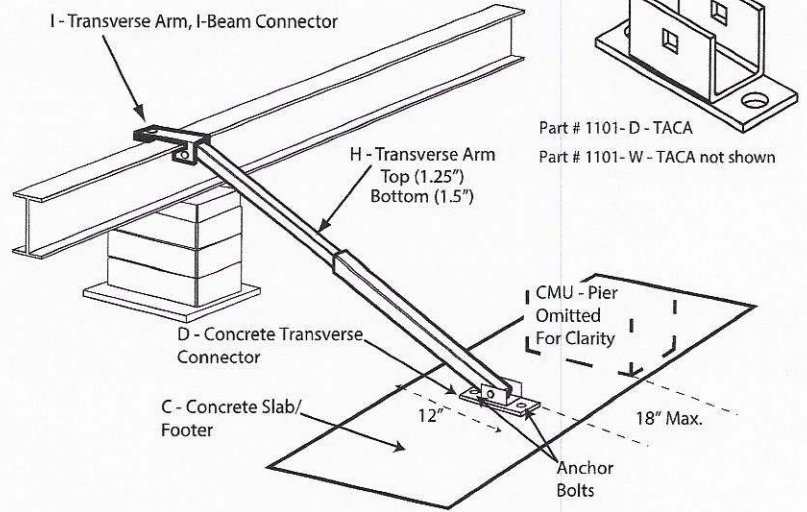

**Model # 1101 TC "V"**

Florida approved 4' ground anchors may be used in all locations except where home manufacturers specifications for sidewall straps are in excess of 4,000 lbs. These locations require a 5' anchor. Per Florida code.

C = GROUND PAN / CONCRETE FOOTER OR RUNNER

D = GROUND PAN / CONCRETE U BRACKETS TRANSVERSE CONNECTOR (connects with grade 5 - 1/2" x 2" 1/2" carriage bolt and nut)

E = TELESCOPING V BRACE TUBE ASSEMBLY (1.5" TUBE BOTTOM AND 1.25" TUBE INSERT) OR 1.5" TUBE

F = "V" BRACE I-BEAM CONNECTOR ASSEMBLY

H = TELESCOPING TRANSVERSE ARM ASSEMBLY

I = TRANSVERSE ARM I-BEAM CONNECTOR (connects with grade 5 - 1/2" x 2" 1/2" carriage bolt and nut)

J = V PAN BRACKET (connects with grade 5 - 1/2" x 2" 1/2" carriage bolt and nut)

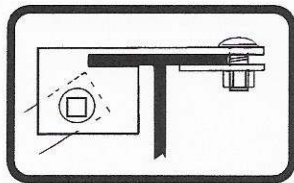

I - Transverse Arm, I-Beam Connector

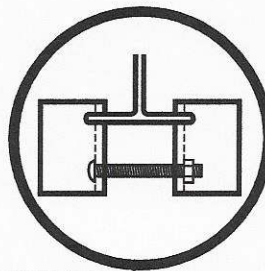

F - "V" Brace I-Beam Connectors

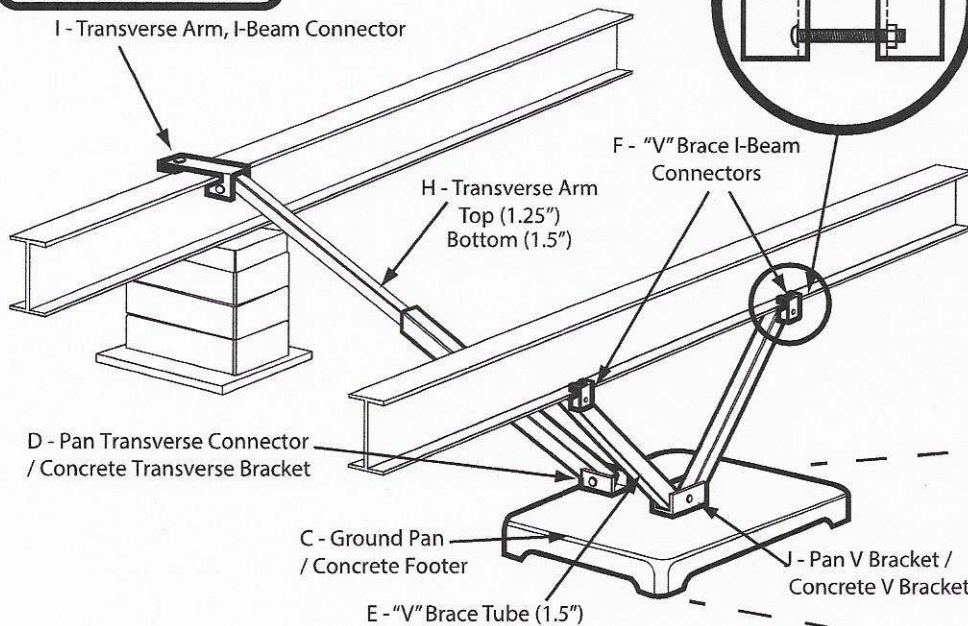

**Model # 1101 "V"**

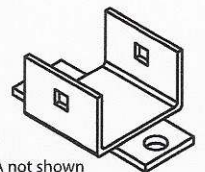

Part# 1101 D-CPCA

Part # 1101 W-CPCA not shown

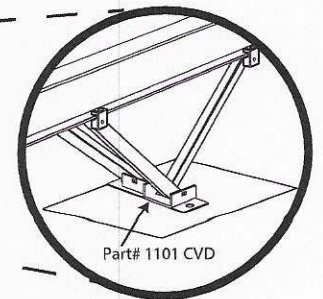

Part# 1101 CVD

**Model # 1101 C "V"**



State of Florida  
**DEPARTMENT OF  
HIGHWAY SAFETY AND MOTOR VEHICLES**

TALLAHASSEE, FLORIDA 32399-0500

**FRED O. DICKINSON, III**  
Executive Director

October 27, 1999

Mr. Lon Larson, General Manager  
Manufactured Housing Foundation Systems  
A Division of Oliver Technologies  
562 Glenheather Drive  
San Marcos, California 92069

Dear Mr. Larson:

We wish to acknowledge receipt of your print specifications and test results certifying your Adjustable Outrigger listed below complies with the Federal Manufactured Construction and Safety Standards, § 3280.305 and § 3280.401 and with the rules and regulations set forth by the Department of Highway Safety and Motor Vehicles, Florida Administrative Rule Code 15C-1.01105.

Based on the information submitted to the bureau, the following product is listed for use in Florida when the installation instructions showing the way the outrigger was tested, are provided.

MODEL #	IDENTIFICATION	DESCRIPTION
1055-11	Adjustable Outrigger	Bracket, Pipe, & Screw Adjustment

NOTE: The outrigger was tested on September 19, 1999, for an allowable load of 1700 pounds.

If you have any questions, please advise at (850) 413-7600.

Sincerely,

Phil Bergelt, Program Manager  
Bureau of Mobile Home and  
Recreational Vehicle Construction  
Division of Motor Vehicles

PB:bsc



## OLIVER TECHNOLOGIES, INC. Adjustable Outrigger Installation Instructions MODEL # 1055-11

1. Locate the floor joist that requires support.
2. Mark the I-Beam directly under the floor joist to align the outrigger.
3. Adjust the nut on the threaded rod so it clears the frame flange for easy adjustment.
4. Set the threaded rod in the pipe and against the frame.
5. Set the notched end of the thrust bracket into the end of the pipe and secure it with 5 # 12 x 2" screws to the floor joist. The thrust bracket should be approximately 6" from the outside rim joist.
6. Bottom board and insulation should be between the bracket and the joist.
7. For minor adjustments align the door and window openings by tightening or loosening the adjustment nut. For all other adjustments use a hydraulic jack to raise the floor joist before installation of the outrigger.

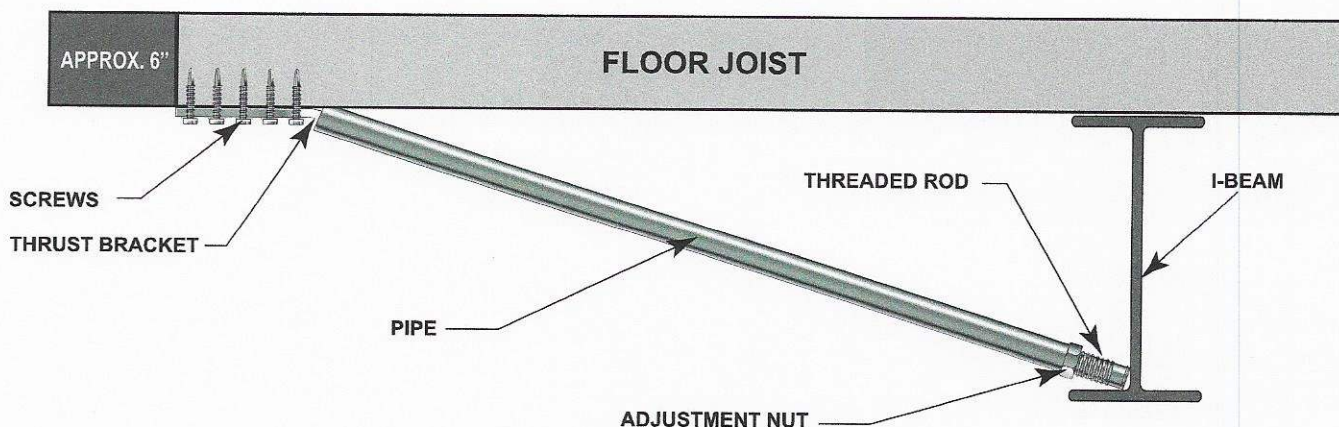

### NOTES:

\*REMOVE OUTRIGGER WHEN HOME IS BEING TRANSPORTED

\*SPECIFY WIDTH OF HOME WHEN ORDERING OUTRIGGER. PIPE MAY BE CUT TO FIT

\*THE ADJUSTABLE OUTRIGGERS SHALL ONLY BE USED ON HOMES FOR OPENINGS UP TO:

6' ON 20 LB ROOF LOAD

4' ON 30 LB ROOF LOAD

3' ON 40 LB ROOF LOAD

\*WHEN ADJUSTABLE OUTRIGGERS ARE USED FOR DOOR AND WINDOW SUPPORTS, THEY MUST BE INSTALLED ON THE CLOSEST FLOOR JOIST UP TO 16" FROM THE OUTSIDE EDGE OF THE OPENING

\*DO NOT INSTALL ADJUSTABLE OUTRIGGER AT LOCATIONS WHERE THE HOME MANUFACTURER INDICATES A LOAD IN EXCESS OF 1,700 LBS.

\*THE ADJUSTABLE OUTRIGGER MUST BE USED ON A MINIMUM 10" I-BEAM AND BE PLACED WITHIN 4' OF A MAIN FRAME SUPPORT PIER OR FRAME CROSSMEMBER.

**Listing # 1055-11**

**Patent # 6.334.279**

# STAIR DETAIL

2023 FLORIDA BUILDING CODE 8TH EDITION.  
RESIDENTIAL SECTIONS R311 AND 312.

- R311.7.2 HEADROOM
- R311.7.5 RISER HEIGHT
- R311.7.5.2 TREAD DEPTH
- R311.7.8.2 HANDRAILS
- R311.7.8.3 CONTINUITY
- R311.7.8 HANDRAIL GRIP SIZE
- R312.1.2 -GUARDS
- R312.1.3 GUARD OPENING LIMITS

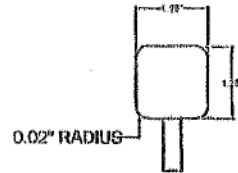

HANDRAIL THAT IS NOT CIRCULAR MUST HAVE A PERIMETER OF 4.0" MIN AND 6.25" MAX WITH A CROSS SECTION DIMENSION OF 2.25"

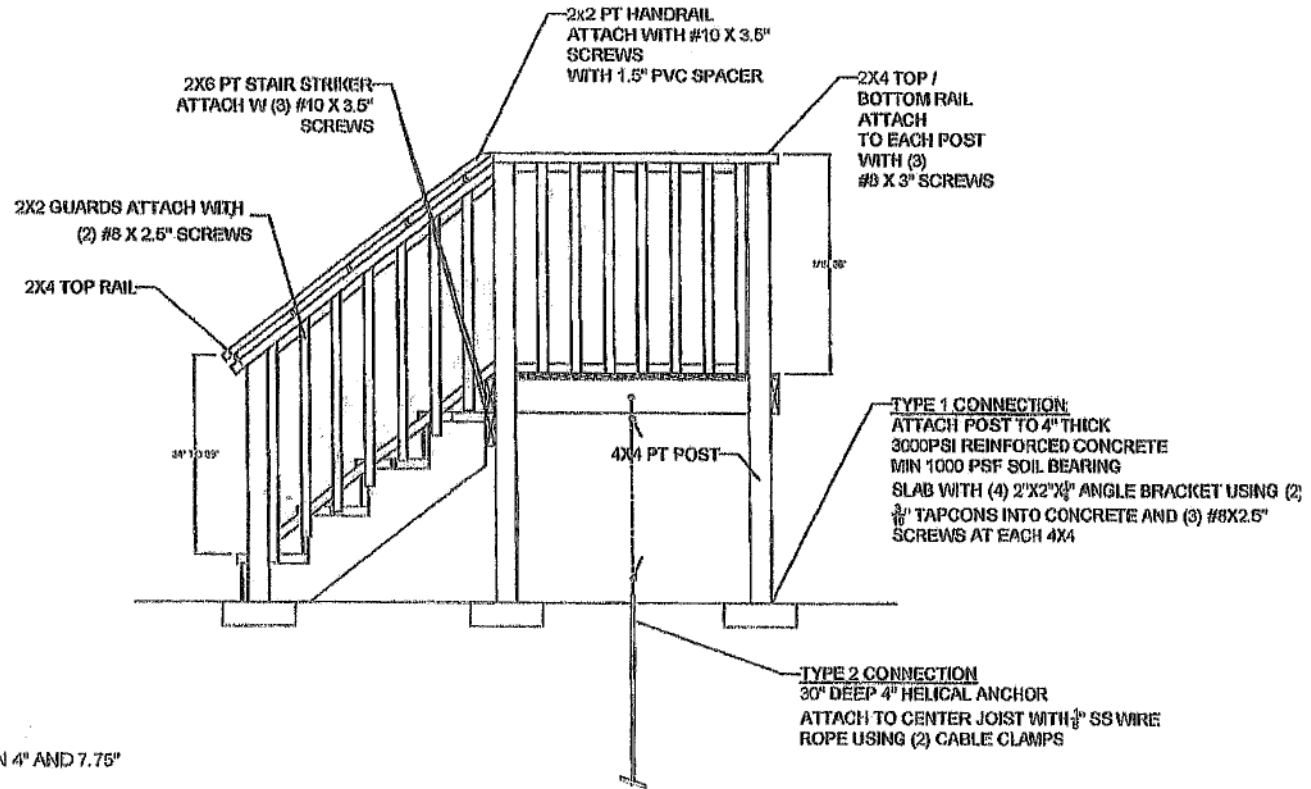

**NOTES:**

- STEP HAS A MIN 40"X40" LANDING
- STEP HAS A RISER HEIGHT OF BETWEEN 4" AND 7.75"
- HANDRAIL HEIGHT 36"
- 2"X2" HANDRAIL " RADIUS ALL SIDES
- GUARDRAIL TO BE 36"
- OPENING WILL REJECT 4" SPHERE

**TYPICAL HANDRAIL CONSTRUCTION DETAILS**

## INSTALLATION VERTICAL SKIRTING (WALL SECTION)

1. Top back rail will be screwed to bottom of home with 3/4" screw every 16".
2. Bottom track will be spiked every 16" with 7" galvanized nail.
3. Each panel must be installed with required screws. Screws installed in each panel top and bottom every 16".
4. Access allowed by any panel.
5. Any part of home over 36" from bottom of home to ground will require metal bracing with cross brace. (Bracing requirements 2 x 3 metal brace attached to bottom of home with 3/4" screws and buried in the ground every 4' with cross brace.)

