



Lumber design values are in accordance with ANSI/TPI 1 section 6.3
These truss designs rely on lumber values established by others.

RE: 3626267 - JT BLDRS - LOT 12 CCP

MiTek, Inc.
16023 Swingley Ridge Rd.
Chesterfield, MO 63017
314.434.1200

Site Information:

Customer Info: JT Builders, LLC Project Name: Custom Model: 1740
Lot/Block: 12 Subdivision: Cannon Creek Place
Address: 630 SW Gerald Connor Drive, TBD
City: Columbia Cty State: FL

Name Address and License # of Structural Engineer of Record, If there is one, for the building.

Name: License #:
Address:
City: State:

General Truss Engineering Criteria & Design Loads (Individual Truss Design Drawings Show Special Loading Conditions):

Design Code: FBC2020/TPI2014 Design Program: MiTek 20/20 8.5
Wind Code: ASCE 7-16 Wind Speed: 130 mph
Roof Load: 37.0 psf Floor Load: N/A psf

This package includes 33 individual, Truss Design Drawings and 0 Additional Drawings.
With my seal affixed to this sheet, I hereby certify that I am the Truss Design Engineer and this index sheet conforms to 61G15-31.003, section 5 of the Florida Board of Professional Engineers Rules.

No.	Seal#	Truss Name	Date	No.	Seal#	Truss Name	Date
1	T31220123	CJ01	8/4/23	15	T31220137	T04	8/4/23
2	T31220124	CJ01A	8/4/23	16	T31220138	T04G	8/4/23
3	T31220125	CJ03	8/4/23	17	T31220139	T05	8/4/23
4	T31220126	CJ03A	8/4/23	18	T31220140	T06	8/4/23
5	T31220127	CJ05	8/4/23	19	T31220141	T07	8/4/23
6	T31220128	CJ05A	8/4/23	20	T31220142	T08	8/4/23
7	T31220129	EJ01	8/4/23	21	T31220143	T09	8/4/23
8	T31220130	EJ02	8/4/23	22	T31220144	T10	8/4/23
9	T31220131	HJ10	8/4/23	23	T31220145	T11	8/4/23
10	T31220132	HJ10A	8/4/23	24	T31220146	T12	8/4/23
11	T31220133	T01	8/4/23	25	T31220147	T13	8/4/23
12	T31220134	T01G	8/4/23	26	T31220148	T14	8/4/23
13	T31220135	T02	8/4/23	27	T31220149	T15	8/4/23
14	T31220136	T03	8/4/23	28	T31220150	T16	8/4/23



This item has been electronically signed and sealed by ORegan, Philip, PE using a Digital Signature.
Printed copies of this document are not considered signed and sealed and the signature must be verified on any electronic copies

The truss drawing(s) referenced above have been prepared by
MiTek USA, Inc. under my direct supervision based on the parameters
provided by Builders FirstSource-Lake City, FL.

Truss Design Engineer's Name: ORegan, Philip
My license renewal date for the state of Florida is February 28, 2025.

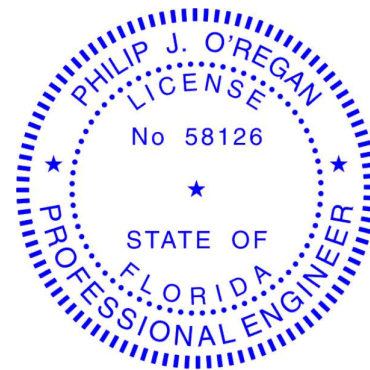

Philip J. O'Regan PE No.58126
MiTek Inc. DBA MiTek USA FL Cert 6634
16023 Swingley Ridge Rd. Chesterfield, MO 63017
Date:

IMPORTANT NOTE: The seal on these truss component designs is a certification that the engineer named is licensed in the jurisdiction(s) identified and that the designs comply with ANSI/TPI 1. These designs are based upon parameters shown (e.g., loads, supports, dimensions, shapes and design codes), which were given to MiTek or TRENCO. Any project specific information included is for MiTek's or TRENCO's customers file reference purpose only, and was not taken into account in the preparation of these designs. MiTek or TRENCO has not independently verified the applicability of the design parameters or the designs for any particular building. Before use, the building designer should verify applicability of design parameters and properly incorporate these designs into the overall building design per ANSI/TPI 1, Chapter 2.

August 4, 2023



RE: 3626267 - JT BLDRS - LOT 12 CCP

MiTek, Inc.
16023 Swingley Ridge Rd.
Chesterfield, MO 63017
314.434.1200

Site Information:

Customer Info: JT Builders, LLC Project Name: Custom Model: 1740
Lot/Block: 12 Subdivision: Cannon Creek Place
Address: 630 SW Gerald Connor Drive, TBD
City: Columbia Cty State: FL

No.	Seal#	Truss Name	Date
29	T31220151	T17	8/4/23
30	T31220152	T18	8/4/23
31	T31220153	T19	8/4/23
32	T31220154	T20	8/4/23
33	T31220155	T21	8/4/23

Job 3626267	Truss CJ01	Truss Type JACK-OPEN	Qty 2	Ply 1	JT BLDRS - LOT 12 CCP	T31220123
----------------	---------------	-------------------------	----------	----------	-----------------------	-----------

Builders FirstSource, Lake City, FL 32055

8.530 s May 26 2022 MiTek Industries, Inc. Fri Aug 4 10:50:34 2023 Page 1
 ID:2eRY39KFhR2benj7cX?4RUzckGi-U?3gUEIWvcF4JxwdYh8Uls6NeYNbe6e8i6lrH4yrPzp

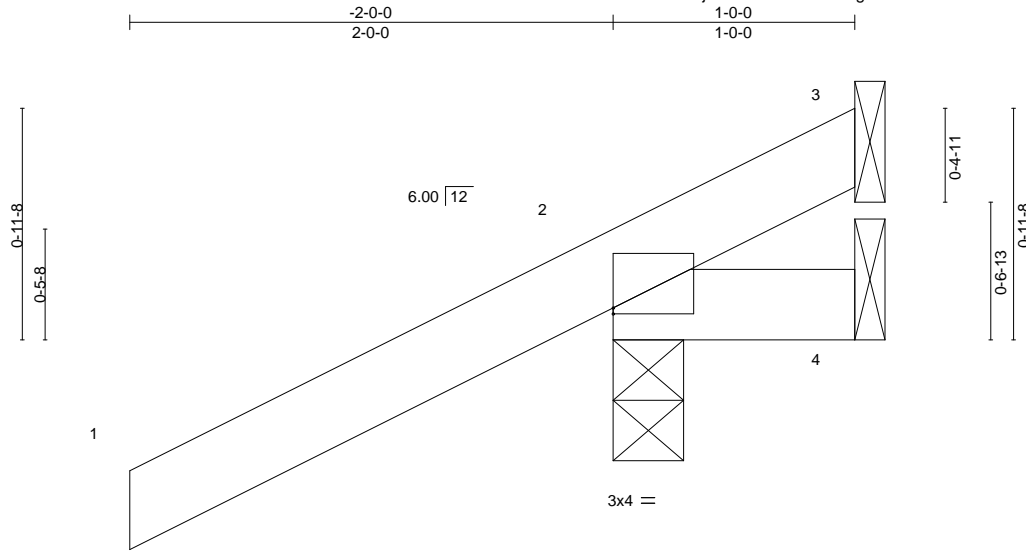

Scale = 1:9.5

Plate Offsets (X,Y)-- [2:0-0-0,0-0-5]

LOADING (psf)	SPACING-	2-0-0	CSI.	DEFL.	in (loc)	l/defl	L/d	PLATES	GRIP
TCLL 20.0	Plate Grip DOL	1.25	TC 0.25	Vert(LL)	0.00	7	>999	MT20	244/190
TCDL 7.0	Lumber DOL	1.25	BC 0.07	Vert(CT)	0.00	7	>999		
BCLL 0.0 *	Rep Stress Incr	YES	WB 0.00	Horz(CT)	0.00	2	n/a		
BCDL 10.0	Code	FBC2020/TPI2014	Matrix-MP					Weight: 7 lb	FT = 20%

LUMBER-

TOP CHORD 2x4 SP No.2
 BOT CHORD 2x4 SP No.2

BRACING-

TOP CHORD Structural wood sheathing directly applied or 1-0-0 oc purlins.
 BOT CHORD Rigid ceiling directly applied or 10-0-0 oc bracing.

REACTIONS.

(size) 3=Mechanical, 2=0-3-8, 4=Mechanical
 Max Horz 2=45(LC 12)
 Max Uplift 3=-28(LC 1), 2=-94(LC 12), 4=-45(LC 1)
 Max Grav 3=14(LC 8), 2=254(LC 1), 4=26(LC 16)

FORCES. (lb) - Max. Comp./Max. Ten. - All forces 250 (lb) or less except when shown.

NOTES-

- 1) Wind: ASCE 7-16; Vult=130mph (3-second gust) Vasd=101mph; TCDL=4.2psf; BCDL=3.0psf; h=18ft; Cat. II; Exp B; Encl., GCpi=0.18; MWFRS (envelope) gable end zone and C-C Exterior(2E) zone;C-C for members and forces & MWFRS for reactions shown; Lumber DOL=1.60 plate grip DOL=1.60
- 2) Building Designer / Project engineer responsible for verifying applied roof live load shown covers rain loading requirements specific to the use of this truss component.
- 3) This truss has been designed for a 10.0 psf bottom chord live load nonconcurrent with any other live loads.
- 4) * This truss has been designed for a live load of 20.0psf on the bottom chord in all areas where a rectangle 3-6-0 tall by 2-0-0 wide will fit between the bottom chord and any other members.
- 5) Refer to girder(s) for truss to truss connections.
- 6) Provide mechanical connection (by others) of truss to bearing plate capable of withstanding 28 lb uplift at joint 3, 94 lb uplift at joint 2 and 45 lb uplift at joint 4.

This item has been electronically signed and sealed by ORegan, Philip, PE using a Digital Signature. Printed copies of this document are not considered signed and sealed and the signature must be verified on any electronic copies.

Philip J. O'Regan PE No.58126
 MiTek Inc. DBA MiTek USA FL Cert 6634
 16023 Swingley Ridge Rd. Chesterfield, MO 63017
 Date:

August 4,2023

WARNING - Verify design parameters and READ NOTES ON THIS AND INCLUDED MITEK REFERENCE PAGE MII-7473 rev. 1/2/2023 BEFORE USE.

Design valid for use only with MiTek® connectors. This design is based only upon parameters shown, and is for an individual building component, not a truss system. Before use, the building designer must verify the applicability of design parameters and properly incorporate this design into the overall building design. Bracing indicated is to prevent buckling of individual truss web and/or chord members only. Additional temporary and permanent bracing is always required for stability and to prevent collapse with possible personal injury and property damage. For general guidance regarding the fabrication, storage, delivery, erection and bracing of trusses and truss systems, see **ANSI/TPI1 Quality Criteria and DSB-22** available from Truss Plate Institute (www.tpinst.org) and **BCSI Building Component Safety Information** available from the Structural Building Component Association (www.sbcsccomponents.com)

MiTek®

16023 Swingley Ridge Rd.
 Chesterfield, MO 63017
 314.434.1200 / MiTek-US.com

Job 3626267	Truss CJ01A	Truss Type JACK-OPEN	Qty 2	Ply 1	JT BLDRS - LOT 12 CCP	T31220124
----------------	----------------	-------------------------	----------	----------	-----------------------	-----------

Builders FirstSource, Lake City, FL 32055

8.530 s May 26 2022 MiTek Industries, Inc. Fri Aug 4 10:50:34 2023 Page 1
ID:2eRY39KFhR2benj7cX?4RUzckGi-U?3gUEIWvcF4JxwdYh8Uls6NeYO2e6e8i6lrH4yrPzp

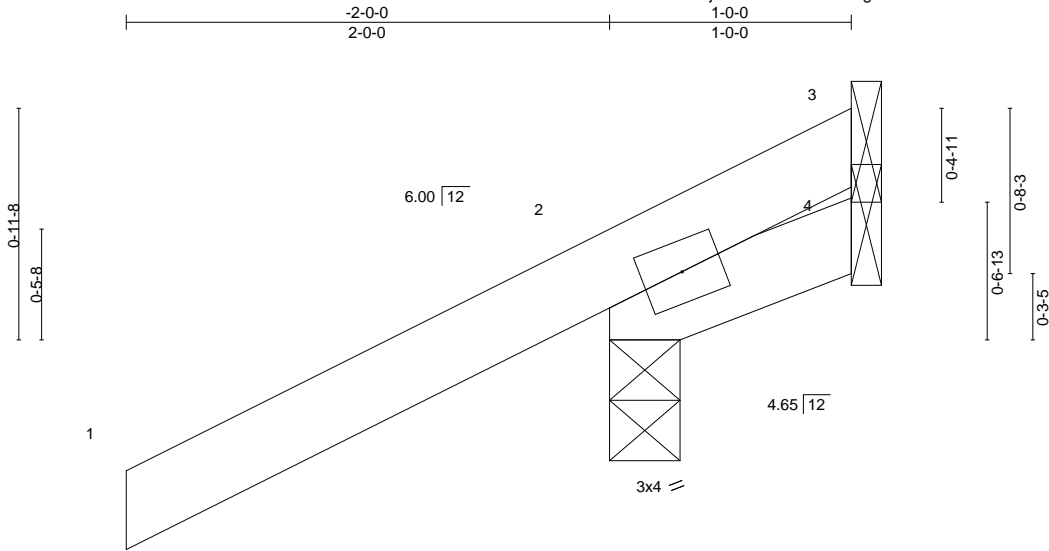

Scale = 1:9.5

LOADING (psf)	SPACING-	2-0-0	CSI.	DEFL.	in (loc)	l/defl	L/d	PLATES	GRIP	
TCLL 20.0	Plate Grip DOL	1.25	TC 0.25	Vert(LL)	0.00	5	>999	240	MT20	244/190
TCDL 7.0	Lumber DOL	1.25	BC 0.04	Vert(CT)	0.00	5	>999	180		
BCLL 0.0 *	Rep Stress Incr	YES	WB 0.00	Horz(CT)	-0.00	2	n/a	n/a		
BCDL 10.0	Code	FBC2020/TPI2014	Matrix-MP						Weight: 7 lb	FT = 20%

LUMBER-

TOP CHORD 2x4 SP No.2
BOT CHORD 2x4 SP No.2

BRACING-

TOP CHORD Structural wood sheathing directly applied or 1-0-0 oc purlins.
BOT CHORD Rigid ceiling directly applied or 6-0-0 oc bracing.

REACTIONS.

(size) 3=Mechanical, 2=0-3-8, 4=Mechanical
Max Horz 2=45(LC 12)
Max Uplift 3=-29(LC 1), 2=-90(LC 12), 4=-44(LC 1)
Max Grav 3=14(LC 16), 2=254(LC 1), 4=22(LC 16)

FORCES. (lb) - Max. Comp./Max. Ten. - All forces 250 (lb) or less except when shown.

NOTES-

- 1) Wind: ASCE 7-16; Vult=130mph (3-second gust) Vasd=101mph; TCDL=4.2psf; BCDL=3.0psf; h=18ft; Cat. II; Exp B; Encl., GCpi=0.18; MWFRS (envelope) gable end zone and C-C Exterior(2E) zone; C-C for members and forces & MWFRS for reactions shown; Lumber DOL=1.60 plate grip DOL=1.60
- 2) Building Designer / Project engineer responsible for verifying applied roof live load shown covers rain loading requirements specific to the use of this truss component.
- 3) This truss has been designed for a 10.0 psf bottom chord live load nonconcurrent with any other live loads.
- 4) * This truss has been designed for a live load of 20.0psf on the bottom chord in all areas where a rectangle 3-6-0 tall by 2-0-0 wide will fit between the bottom chord and any other members.
- 5) Refer to girder(s) for truss to truss connections.
- 6) Bearing at joint(s) 2 considers parallel to grain value using ANSI/TPI 1 angle to grain formula. Building designer should verify capacity of bearing surface.
- 7) Provide mechanical connection (by others) of truss to bearing plate capable of withstanding 29 lb uplift at joint 3, 90 lb uplift at joint 2 and 44 lb uplift at joint 4.

This item has been electronically signed and sealed by O'Regan, Philip, PE using a Digital Signature. Printed copies of this document are not considered signed and sealed and the signature must be verified on any electronic copies.

Philip J. O'Regan PE No.58126
MiTek Inc. DBA MiTek USA FL Cert 6634
16023 Swingley Ridge Rd. Chesterfield, MO 63017
Date:

August 4, 2023

WARNING - Verify design parameters and READ NOTES ON THIS AND INCLUDED MITEK REFERENCE PAGE MII-7473 rev. 1/2/2023 BEFORE USE.

Design valid for use only with MiTek® connectors. This design is based only upon parameters shown, and is for an individual building component, not a truss system. Before use, the building designer must verify the applicability of design parameters and properly incorporate this design into the overall building design. Bracing indicated is to prevent buckling of individual truss web and/or chord members only. Additional temporary and permanent bracing is always required for stability and to prevent collapse with possible personal injury and property damage. For general guidance regarding the fabrication, storage, delivery, erection and bracing of trusses and truss systems, see **ANSI/TPI1 Quality Criteria and DSB-22** available from Truss Plate Institute (www.tpinst.org) and **BCSI Building Component Safety Information** available from the Structural Building Component Association (www.sbcsccomponents.com)

MiTek®

16023 Swingley Ridge Rd.
Chesterfield, MO 63017
314.434.1200 / MiTek-US.com

Job 3626267	Truss CJ03	Truss Type JACK-OPEN	Qty 2	Ply 1	JT BLDRS - LOT 12 CCP	T31220125
----------------	---------------	-------------------------	----------	----------	-----------------------	-----------

Builders FirstSource, Lake City, FL 32055

8.530 s May 26 2022 MiTek Industries, Inc. Fri Aug 4 10:50:35 2023 Page 1
ID:2eRY39KFhR2benj7cX?4RUzckGi-yBd2ham8gwNxx5Vp6Ofjr4eYOyjrNZuHxm1PqXyrPzo

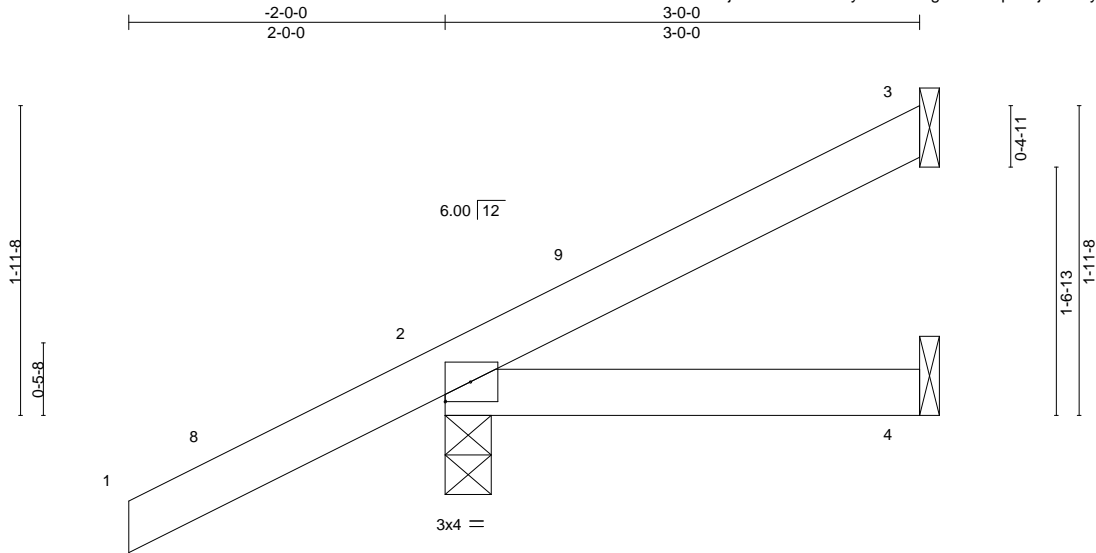

LOADING (psf)	SPACING-	2-0-0	CSI.	DEFL.	in (loc)	l/defl	L/d	PLATES	GRIP	
TCLL 20.0	Plate Grip DOL	1.25	TC 0.25	Vert(LL)	-0.00	4-7	>999	240	MT20	244/190
TCDL 7.0	Lumber DOL	1.25	BC 0.07	Vert(CT)	-0.01	4-7	>999	180		
BCLL 0.0 *	Rep Stress Incr	YES	WB 0.00	Horz(CT)	0.00	3	n/a	n/a		
BCDL 10.0	Code	FBC2020/TPI2014	Matrix-MP						Weight: 13 lb	FT = 20%

LUMBER-

TOP CHORD 2x4 SP No.2
BOT CHORD 2x4 SP No.2

BRACING-

TOP CHORD Structural wood sheathing directly applied or 3-0-0 oc purlins.
BOT CHORD Rigid ceiling directly applied or 10-0-0 oc bracing.

REACTIONS.

(size) 3=Mechanical, 2=0-3-8, 4=Mechanical
Max Horz 2=78(LC 12)
Max Uplift 3=-33(LC 12), 2=-71(LC 12)
Max Grav 3=53(LC 1), 2=253(LC 1), 4=48(LC 3)

FORCES. (lb) - Max. Comp./Max. Ten. - All forces 250 (lb) or less except when shown.

NOTES-

- 1) Wind: ASCE 7-16; Vult=130mph (3-second gust) Vasd=101mph; TCDL=4.2psf; BCDL=3.0psf; h=18ft; Cat. II; Exp B; Encl., GCpi=0.18; MWFRS (envelope) gable end zone and C-C Exterior(2E) -2-0-0 to 1-0-0, Interior(1) 1-0-0 to 2-11-4 zone;C-C for members and forces & MWFRS for reactions shown; Lumber DOL=1.60 plate grip DOL=1.60
- 2) Building Designer / Project engineer responsible for verifying applied roof live load shown covers rain loading requirements specific to the use of this truss component.
- 3) This truss has been designed for a 10.0 psf bottom chord live load nonconcurrent with any other live loads.
- 4) * This truss has been designed for a live load of 20.0psf on the bottom chord in all areas where a rectangle 3-6-0 tall by 2-0-0 wide will fit between the bottom chord and any other members.
- 5) Refer to girder(s) for truss to truss connections.
- 6) Provide mechanical connection (by others) of truss to bearing plate capable of withstanding 33 lb uplift at joint 3 and 71 lb uplift at joint 2.

This item has been electronically signed and sealed by ORegan, Philip, PE using a Digital Signature. Printed copies of this document are not considered signed and sealed and the signature must be verified on any electronic copies.

Philip J. O'Regan PE No.58126
MiTek Inc. DBA MiTek USA FL Cert 6634
16023 Swingley Ridge Rd. Chesterfield, MO 63017
Date:

August 4, 2023

WARNING - Verify design parameters and READ NOTES ON THIS AND INCLUDED MITEK REFERENCE PAGE MII-7473 rev. 1/2/2023 BEFORE USE.

Design valid for use only with MiTek® connectors. This design is based only upon parameters shown, and is for an individual building component, not a truss system. Before use, the building designer must verify the applicability of design parameters and properly incorporate this design into the overall building design. Bracing indicated is to prevent buckling of individual truss web and/or chord members only. Additional temporary and permanent bracing is always required for stability and to prevent collapse with possible personal injury and property damage. For general guidance regarding the fabrication, storage, delivery, erection and bracing of trusses and truss systems, see **ANSI/TPI1 Quality Criteria and DSB-22** available from Truss Plate Institute (www.tpinst.org) and **BCSI Building Component Safety Information** available from the Structural Building Component Association (www.sbcsccomponents.com)

MiTek®

16023 Swingley Ridge Rd.
Chesterfield, MO 63017
314.434.1200 / MiTek-US.com

Job 3626267	Truss CJ03A	Truss Type JACK-OPEN	Qty 2	Ply 1	JT BLDRS - LOT 12 CCP	T31220126
----------------	----------------	-------------------------	----------	----------	-----------------------	-----------

Builders FirstSource, Lake City, FL 32055

ID:2eRY39KFhR2benj7cX?4RUzckGi-yBd2ham8gwNxx5Vp6Ofjr4eYoyjoNZuHxm1PqXyrPzo
8.530 s May 26 2022 MiTek Industries, Inc. Fri Aug 4 10:50:35 2023 Page 1

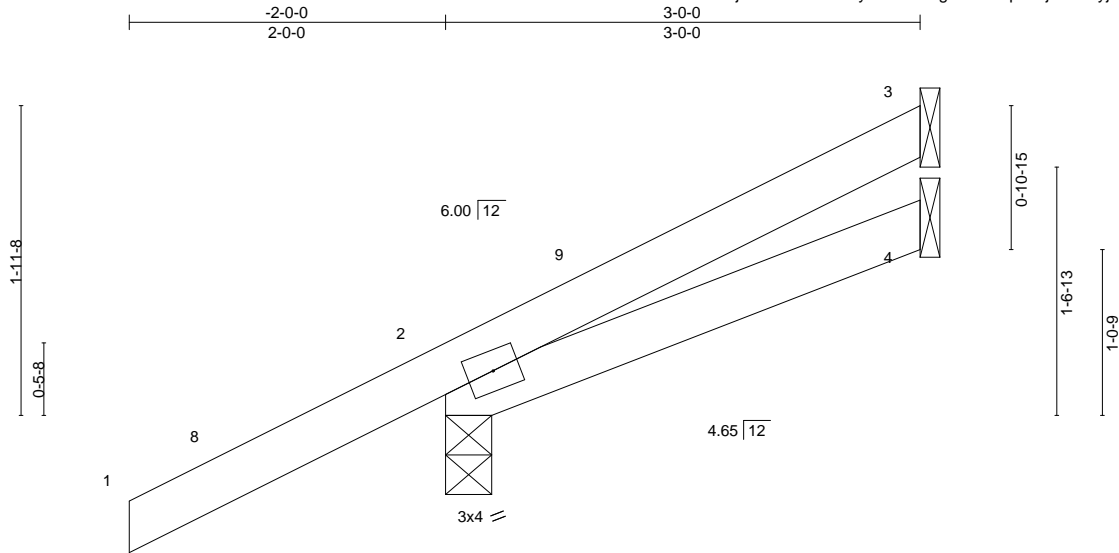

Scale = 1:14.6

LOADING (psf)	SPACING-	2-0-0	CSI.	DEFL.	in (loc)	l/defl	L/d	PLATES	GRIP
TCLL 20.0	Plate Grip DOL	1.25	TC 0.25	Vert(LL)	-0.00	4-7	>999	MT20	244/190
TCDL 7.0	Lumber DOL	1.25	BC 0.07	Vert(CT)	-0.01	4-7	>999		
BCLL 0.0 *	Rep Stress Incr	YES	WB 0.00	Horz(CT)	0.00	3	n/a		
BCDL 10.0	Code	FBC2020/TPI2014	Matrix-MP					Weight: 13 lb	FT = 20%

LUMBER-

TOP CHORD 2x4 SP No.2
BOT CHORD 2x4 SP No.2

BRACING-

TOP CHORD Structural wood sheathing directly applied or 3-0-0 oc purlins.
BOT CHORD Rigid ceiling directly applied or 6-0-0 oc bracing.

REACTIONS.

(size) 3=Mechanical, 2=0-3-8, 4=Mechanical
Max Horz 2=78(LC 12)
Max Uplift 3=-32(LC 12), 2=-68(LC 12)
Max Grav 3=51(LC 1), 2=253(LC 1), 4=47(LC 3)

FORCES. (lb) - Max. Comp./Max. Ten. - All forces 250 (lb) or less except when shown.

NOTES-

- 1) Wind: ASCE 7-16; Vult=130mph (3-second gust) Vasd=101mph; TCDL=4.2psf; BCDL=3.0psf; h=18ft; Cat. II; Exp B; Encl., GCpi=0.18; MWFRS (envelope) gable end zone and C-C Exterior(2E) -2-0-0 to 1-0-0, Interior(1) 1-0-0 to 2-11-4 zone;C-C for members and forces & MWFRS for reactions shown; Lumber DOL=1.60 plate grip DOL=1.60
- 2) Building Designer / Project engineer responsible for verifying applied roof live load shown covers rain loading requirements specific to the use of this truss component.
- 3) This truss has been designed for a 10.0 psf bottom chord live load nonconcurrent with any other live loads.
- 4) * This truss has been designed for a live load of 20.0psf on the bottom chord in all areas where a rectangle 3-6-0 tall by 2-0-0 wide will fit between the bottom chord and any other members.
- 5) Refer to girder(s) for truss to truss connections.
- 6) Bearing at joint(s) 2 considers parallel to grain value using ANSI/TPI 1 angle to grain formula. Building designer should verify capacity of bearing surface.
- 7) Provide mechanical connection (by others) of truss to bearing plate capable of withstanding 32 lb uplift at joint 3 and 68 lb uplift at joint 2.

This item has been electronically signed and sealed by ORegan, Philip, PE using a Digital Signature. Printed copies of this document are not considered signed and sealed and the signature must be verified on any electronic copies.

Philip J. O'Regan PE No.58126
MiTek Inc. DBA MiTek USA FL Cert 6634
16023 Swingley Ridge Rd. Chesterfield, MO 63017
Date:

August 4, 2023

WARNING - Verify design parameters and READ NOTES ON THIS AND INCLUDED MITEK REFERENCE PAGE MII-7473 rev. 1/2/2023 BEFORE USE.

Design valid for use only with MiTek® connectors. This design is based only upon parameters shown, and is for an individual building component, not a truss system. Before use, the building designer must verify the applicability of design parameters and properly incorporate this design into the overall building design. Bracing indicated is to prevent buckling of individual truss web and/or chord members only. Additional temporary and permanent bracing is always required for stability and to prevent collapse with possible personal injury and property damage. For general guidance regarding the fabrication, storage, delivery, erection and bracing of trusses and truss systems, see **ANSI/TPI1 Quality Criteria and DSB-22** available from Truss Plate Institute (www.tpinst.org) and **BCSI Building Component Safety Information** available from the Structural Building Component Association (www.sbcsccomponents.com)

MiTek®

16023 Swingley Ridge Rd.
Chesterfield, MO 63017
314.434.1200 / MiTek-US.com

Job 3626267	Truss CJ05	Truss Type JACK-OPEN	Qty 2	Ply 1	JT BLDRS - LOT 12 CCP T31220127
----------------	---------------	-------------------------	----------	----------	------------------------------------

Builders FirstSource, Lake City, FL 32055

8.530 s May 26 2022 MiTek Industries, Inc. Fri Aug 4 10:50:35 2023 Page 1

ID:2eRY39KFhR2benj7cX?4RUzckGi-yBd2ham8gwNxx5Vp6Ofjr4eX5yhENZuHxm1PqXyrPzo

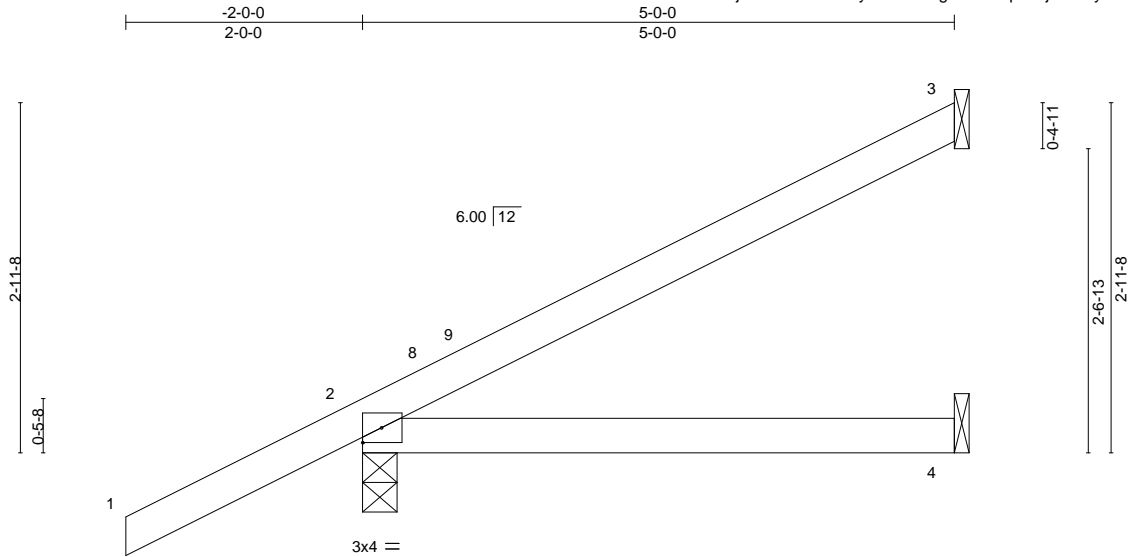

LOADING (psf)	SPACING- 2-0-0	CSI.	DEFL. in (loc) l/defl L/d	PLATES	GRIP
TCLL 20.0	Plate Grip DOL 1.25	TC 0.26	Vert(LL) -0.02 4-7 >999 240	MT20	244/190
TCDL 7.0	Lumber DOL 1.25	BC 0.24	Vert(CT) -0.05 4-7 >999 180		
BCLL 0.0 *	Rep Stress Incr YES	WB 0.00	Horz(CT) 0.01 3 n/a n/a		
BCDL 10.0	Code FBC2020/TPI2014	Matrix-MP		Weight: 19 lb	FT = 20%

LUMBER-

TOP CHORD 2x4 SP No.2
BOT CHORD 2x4 SP No.2

BRACING-

TOP CHORD Structural wood sheathing directly applied or 5-0-0 oc purlins.
BOT CHORD Rigid ceiling directly applied or 10-0-0 oc bracing.

REACTIONS.

(size) 3=Mechanical, 2=0-3-8, 4=Mechanical
Max Horz 2=111(LC 12)
Max Uplift 3=64(LC 12), 2=74(LC 12)
Max Grav 3=109(LC 1), 2=313(LC 1), 4=87(LC 3)

FORCES. (lb) - Max. Comp./Max. Ten. - All forces 250 (lb) or less except when shown.

NOTES-

- 1) Wind: ASCE 7-16; Vult=130mph (3-second gust) Vasd=101mph; TCDL=4.2psf; BCDL=3.0psf; h=18ft; Cat. II; Exp B; Encl., GCpi=0.18; MWFRS (envelope) gable end zone and C-C Exterior(2E) -2-0-0 to 1-0-0, Interior(1) 1-0-0 to 4-11-4 zone;C-C for members and forces & MWFRS for reactions shown; Lumber DOL=1.60 plate grip DOL=1.60
- 2) Building Designer / Project engineer responsible for verifying applied roof live load shown covers rain loading requirements specific to the use of this truss component.
- 3) This truss has been designed for a 10.0 psf bottom chord live load nonconcurrent with any other live loads.
- 4) * This truss has been designed for a live load of 20.0psf on the bottom chord in all areas where a rectangle 3-6-0 tall by 2-0-0 wide will fit between the bottom chord and any other members.
- 5) Refer to girder(s) for truss to truss connections.
- 6) Provide mechanical connection (by others) of truss to bearing plate capable of withstanding 64 lb uplift at joint 3 and 74 lb uplift at joint 2.

This item has been electronically signed and sealed by ORegan, Philip, PE using a Digital Signature. Printed copies of this document are not considered signed and sealed and the signature must be verified on any electronic copies.

Philip J. O'Regan PE No.58126
MiTek Inc. DBA MiTek USA FL Cert 6634
16023 Swingley Ridge Rd. Chesterfield, MO 63017
Date:

August 4, 2023

WARNING - Verify design parameters and READ NOTES ON THIS AND INCLUDED MITEK REFERENCE PAGE MII-7473 rev. 1/2/2023 BEFORE USE.

Design valid for use only with MiTek® connectors. This design is based only upon parameters shown, and is for an individual building component, not a truss system. Before use, the building designer must verify the applicability of design parameters and properly incorporate this design into the overall building design. Bracing indicated is to prevent buckling of individual truss web and/or chord members only. Additional temporary and permanent bracing is always required for stability and to prevent collapse with possible personal injury and property damage. For general guidance regarding the fabrication, storage, delivery, erection and bracing of trusses and truss systems, see **ANSI/TPI1 Quality Criteria and DSB-22** available from Truss Plate Institute (www.tpinst.org) and **BCSI Building Component Safety Information** available from the Structural Building Component Association (www.sbcsccomponents.com)

MiTek®

16023 Swingley Ridge Rd.
Chesterfield, MO 63017
314.434.1200 / MiTek-US.com

Job 3626267	Truss CJ05A	Truss Type JACK-OPEN	Qty 2	Ply 1	JT BLDRS - LOT 12 CCP	T31220128
----------------	----------------	-------------------------	----------	----------	-----------------------	-----------

Builders FirstSource, Lake City, FL 32055

8.530 s May 26 2022 MiTek Industries, Inc. Fri Aug 4 10:50:36 2023 Page 1

ID:2eRY39KfHr2benj7cX?4RUzckGi-QOBQvwmQEVozF40f5ByOHByM1d608RAQnyMzYrPzn

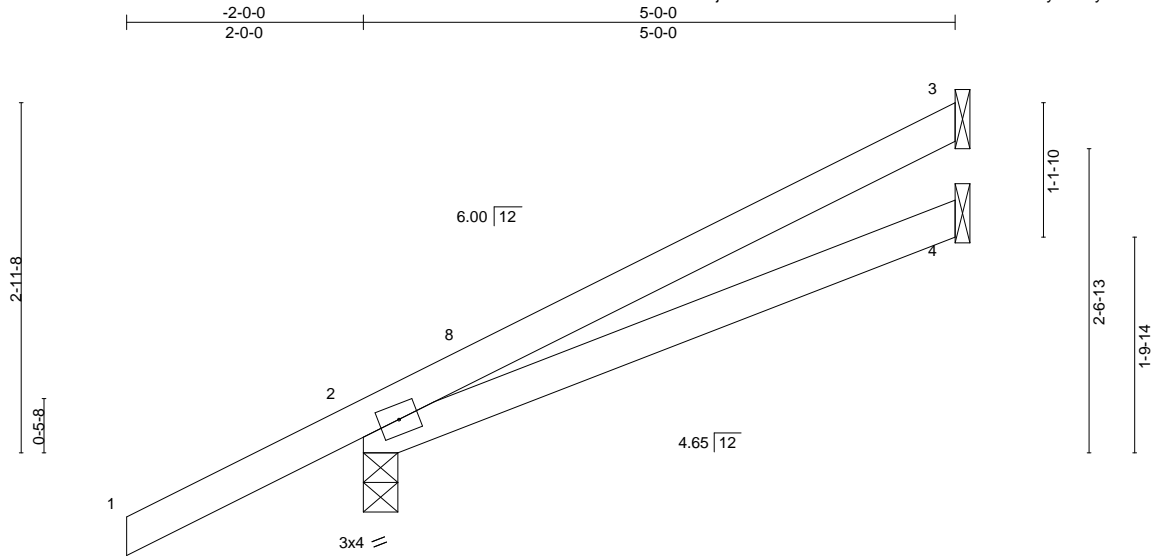

LOADING (psf)	SPACING-	CSI.	DEFL.	in (loc)	l/defl	L/d	PLATES	GRIP
TCLL 20.0	2-0-0	TC 0.26	Vert(LL)	0.03	4-7	>999	MT20	244/190
TCDL 7.0	Plate Grip DOL 1.25	BC 0.23	Vert(CT)	-0.05	4-7	>999		
BCLL 0.0 *	Lumber DOL 1.25	WB 0.00	Horz(CT)	0.01	3	n/a		
BCDL 10.0	Rep Stress Incr YES	Matrix-MP					Weight: 20 lb	FT = 20%
	Code FBC2020/TPI2014							

LUMBER-

TOP CHORD 2x4 SP No.2
BOT CHORD 2x4 SP No.2

BRACING-

TOP CHORD Structural wood sheathing directly applied or 5-0-0 oc purlins.
BOT CHORD Rigid ceiling directly applied or 6-0-0 oc bracing.

REACTIONS.

(size) 3=Mechanical, 2=0-3-8, 4=Mechanical
Max Horz 2=111(LC 12)
Max Uplift 3=63(LC 12), 2=72(LC 12)
Max Grav 3=108(LC 1), 2=313(LC 1), 4=86(LC 3)

FORCES. (lb) - Max. Comp./Max. Ten. - All forces 250 (lb) or less except when shown.

NOTES-

- 1) Wind: ASCE 7-16; Vult=130mph (3-second gust) Vasd=101mph; TCDL=4.2psf; BCDL=3.0psf; h=18ft; Cat. II; Exp B; Encl., GCpi=0.18; MWFRS (envelope) gable end zone and C-C Exterior(2E) -2-0-0 to 1-0-0, Interior(1) 1-0-0 to 4-11-4 zone;C-C for members and forces & MWFRS for reactions shown; Lumber DOL=1.60 plate grip DOL=1.60
- 2) Building Designer / Project engineer responsible for verifying applied roof live load shown covers rain loading requirements specific to the use of this truss component.
- 3) This truss has been designed for a 10.0 psf bottom chord live load nonconcurrent with any other live loads.
- 4) * This truss has been designed for a live load of 20.0psf on the bottom chord in all areas where a rectangle 3-6-0 tall by 2-0-0 wide will fit between the bottom chord and any other members.
- 5) Refer to girder(s) for truss to truss connections.
- 6) Bearing at joint(s) 2 considers parallel to grain value using ANSI/TPI 1 angle to grain formula. Building designer should verify capacity of bearing surface.
- 7) Provide mechanical connection (by others) of truss to bearing plate capable of withstanding 63 lb uplift at joint 3 and 72 lb uplift at joint 2.

This item has been electronically signed and sealed by O'Regan, Philip, PE using a Digital Signature. Printed copies of this document are not considered signed and sealed and the signature must be verified on any electronic copies.

Philip J. O'Regan PE No.58126
MiTek Inc. DBA MiTek USA FL Cert 6634
16023 Swingley Ridge Rd. Chesterfield, MO 63017
Date:

August 4, 2023

WARNING - Verify design parameters and READ NOTES ON THIS AND INCLUDED MITEK REFERENCE PAGE MII-7473 rev. 1/2/2023 BEFORE USE.

Design valid for use only with MiTek® connectors. This design is based only upon parameters shown, and is for an individual building component, not a truss system. Before use, the building designer must verify the applicability of design parameters and properly incorporate this design into the overall building design. Bracing indicated is to prevent buckling of individual truss web and/or chord members only. Additional temporary and permanent bracing is always required for stability and to prevent collapse with possible personal injury and property damage. For general guidance regarding the fabrication, storage, delivery, erection and bracing of trusses and truss systems, see **ANSI/TPI1 Quality Criteria and DSB-22** available from Truss Plate Institute (www.tpinst.org) and **BCSI Building Component Safety Information** available from the Structural Building Component Association (www.sbcsccomponents.com)

MiTek®

16023 Swingley Ridge Rd.
Chesterfield, MO 63017
314.434.1200 / MiTek-US.com

Job 3626267	Truss EJ01	Truss Type JACK-PARTIAL	Qty 16	Ply 1	JT BLDRS - LOT 12 CCP	T31220129
----------------	---------------	----------------------------	-----------	----------	-----------------------	-----------

Builders FirstSource, Lake City, FL 32055

ID:2eRY39KFhR2benj7cX?4RUzckGi-QOBQvwmmQEVoZF40f5ByOHBdMMY7608RAQnyMzYrPzn
8.530 s May 26 2022 MiTek Industries, Inc. Fri Aug 4 10:50:36 2023 Page 1

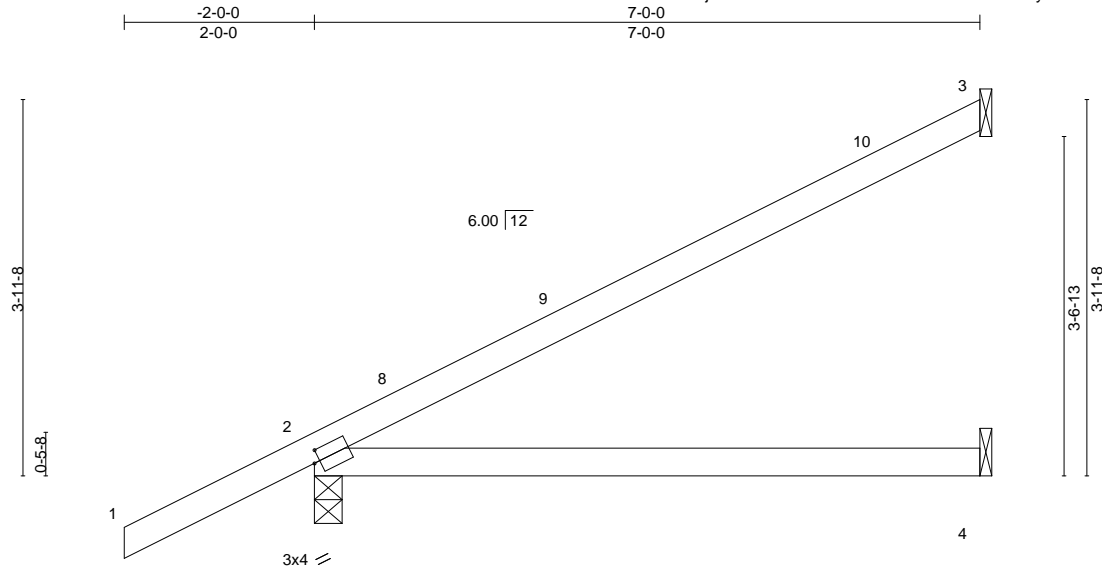

Scale: 1/2"=1'

Plate Offsets (X,Y)-- [2:0-0-12,0-1-8]

LOADING (psf)	SPACING-	CSI.	DEFL.	in (loc)	l/defl	L/d	PLATES	GRIP
TCLL 20.0	2-0-0	TC 0.61	Vert(LL)	-0.10	4-7	>871	MT20	244/190
TCDL 7.0	Plate Grip DOL 1.25	BC 0.51	Vert(CT)	-0.21	4-7	>388		
BCLL 0.0 *	Lumber DOL 1.25	WB 0.00	Horz(CT)	0.01	2	n/a		
BCDL 10.0	Rep Stress Incr YES	Matrix-MS					Weight: 26 lb	FT = 20%
	Code FBC2020/TPI2014							

LUMBER-

TOP CHORD 2x4 SP No.2
BOT CHORD 2x4 SP No.2

BRACING-

TOP CHORD Structural wood sheathing directly applied or 6'-0-0 oc purlins.
BOT CHORD Rigid ceiling directly applied or 10'-0-0 oc bracing.

REACTIONS.

(size) 3=Mechanical, 2=0-3-8, 4=Mechanical
Max Horz 2=140(LC 12)
Max Uplift 3=83(LC 12), 2=84(LC 12)
Max Grav 3=161(LC 1), 2=380(LC 1), 4=125(LC 3)

FORCES. (lb) - Max. Comp./Max. Ten. - All forces 250 (lb) or less except when shown.

NOTES-

- 1) Wind: ASCE 7-16; Vult=130mph (3-second gust) Vasd=101mph; TCDL=4.2psf; BCDL=3.0psf; h=18ft; Cat. II; Exp B; Encl., GCpi=0.18; MWFRS (envelope) gable end zone and C-C Exterior(2E) -2-0-0 to 1-0-0, Interior(1) 1-0-0 to 6-11-4 zone; C-C for members and forces & MWFRS for reactions shown; Lumber DOL=1.60 plate grip DOL=1.60
- 2) Building Designer / Project engineer responsible for verifying applied roof live load shown covers rain loading requirements specific to the use of this truss component.
- 3) This truss has been designed for a 10.0 psf bottom chord live load nonconcurrent with any other live loads.
- 4) * This truss has been designed for a live load of 20.0psf on the bottom chord in all areas where a rectangle 3'-6-0 tall by 2'-0-0 wide will fit between the bottom chord and any other members.
- 5) Refer to girder(s) for truss to truss connections.
- 6) Provide mechanical connection (by others) of truss to bearing plate capable of withstanding 83 lb uplift at joint 3 and 84 lb uplift at joint 2.

This item has been electronically signed and sealed by ORegan, Philip, PE using a Digital Signature. Printed copies of this document are not considered signed and sealed and the signature must be verified on any electronic copies.

Philip J. O'Regan PE No.58126
MiTek Inc. DBA MiTek USA FL Cert 6634
16023 Swingley Ridge Rd. Chesterfield, MO 63017
Date:

August 4, 2023

WARNING - Verify design parameters and READ NOTES ON THIS AND INCLUDED MITEK REFERENCE PAGE MII-7473 rev. 1/2/2023 BEFORE USE.

Design valid for use only with MiTek® connectors. This design is based only upon parameters shown, and is for an individual building component, not a truss system. Before use, the building designer must verify the applicability of design parameters and properly incorporate this design into the overall building design. Bracing indicated is to prevent buckling of individual truss web and/or chord members only. Additional temporary and permanent bracing is always required for stability and to prevent collapse with possible personal injury and property damage. For general guidance regarding the fabrication, storage, delivery, erection and bracing of trusses and truss systems, see **ANSI/TPI1 Quality Criteria and DSB-22** available from Truss Plate Institute (www.tpinst.org) and **BCSI Building Component Safety Information** available from the Structural Building Component Association (www.sbcsccomponents.com)

MiTek®

16023 Swingley Ridge Rd.
Chesterfield, MO 63017
314.434.1200 / MiTek-US.com

Job 3626267	Truss EJ02	Truss Type JACK-PARTIAL	Qty 9	Ply 1	JT BLDRS - LOT 12 CCP	T31220130
----------------	---------------	----------------------------	----------	----------	-----------------------	-----------

Builders FirstSource, Lake City, FL 32055

8.530 s May 26 2022 MiTek Industries, Inc. Fri Aug 4 10:50:37 2023 Page 1
ID:2eRY39KFhR2benj7cX?4RUzckGi-ualp6GnOBXefAPeCDpiBwVkoZIKWrToaP4WWuPyrPzm

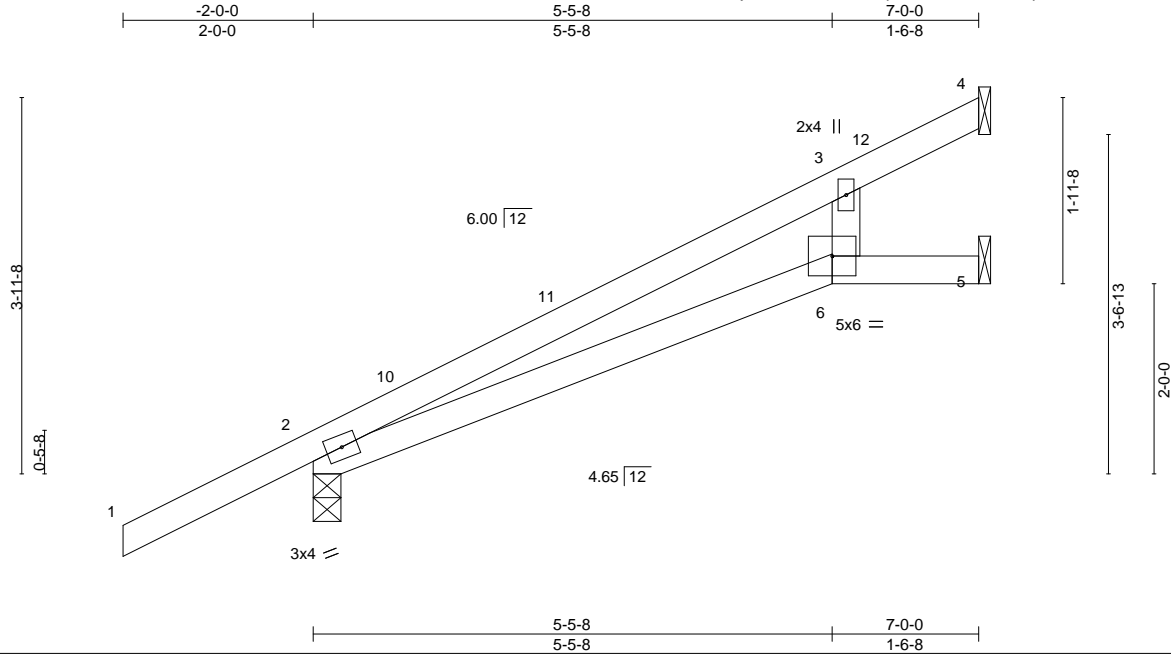

Scale: 1/2"=1'

LOADING (psf)	SPACING-	CSI.	DEFL.	PLATES	GRIP
TCLL 20.0	2-0-0	TC 0.59	in (loc) l/defl L/d	MT20	244/190
TCDL 7.0	Plate Grip DOL 1.25	BC 0.44	Vert(LL) 0.14 6-9 >581 240		
BCLL 0.0 *	Lumber DOL 1.25	WB 0.04	Vert(CT) -0.23 6-9 >366 180		
BCDL 10.0	Rep Stress Incr YES	Matrix-MS	Horz(CT) 0.06 5 n/a n/a		
	Code FBC2020/TPI2014			Weight: 27 lb	FT = 20%

LUMBER-

TOP CHORD 2x4 SP No.2
BOT CHORD 2x4 SP No.2
WEBS 2x4 SP No.3

BRACING-

TOP CHORD Structural wood sheathing directly applied or 6-0-0 oc purlins.
BOT CHORD Rigid ceiling directly applied or 6-0-0 oc bracing.

REACTIONS.

(size) 4=Mechanical, 2=0-3-8, 5=Mechanical
Max Horz 2=140(LC 12)
Max Uplift 4=-51(LC 12), 2=-82(LC 12), 5=-30(LC 12)
Max Grav 4=159(LC 1), 2=380(LC 1), 5=82(LC 1)

FORCES. (lb) - Max. Comp./Max. Ten. - All forces 250 (lb) or less except when shown.

NOTES-

- 1) Wind: ASCE 7-16; Vult=130mph (3-second gust) Vasd=101mph; TC DL=4.2psf; BCDL=3.0psf; h=18ft; Cat. II; Exp B; Encl., GCpi=0.18; MWFRS (envelope) gable end zone and C-C Exterior(2E) -2-0-0 to 1-0-0, Interior(1) 1-0-0 to 6-11-4 zone; C-C for members and forces & MWFRS for reactions shown; Lumber DOL=1.60 plate grip DOL=1.60
- 2) Building Designer / Project engineer responsible for verifying applied roof live load shown covers rain loading requirements specific to the use of this truss component.
- 3) This truss has been designed for a 10.0 psf bottom chord live load nonconcurrent with any other live loads.
- 4) * This truss has been designed for a live load of 20.0psf on the bottom chord in all areas where a rectangle 3-6-0 tall by 2-0-0 wide will fit between the bottom chord and any other members.
- 5) Refer to girder(s) for truss to truss connections.
- 6) Bearing at joint(s) 2 considers parallel to grain value using ANSI/TPI 1 angle to grain formula. Building designer should verify capacity of bearing surface.
- 7) Provide mechanical connection (by others) of truss to bearing plate capable of withstanding 51 lb uplift at joint 4, 82 lb uplift at joint 2 and 30 lb uplift at joint 5.

This item has been electronically signed and sealed by ORegan, Philip, PE using a Digital Signature. Printed copies of this document are not considered signed and sealed and the signature must be verified on any electronic copies.

Philip J. O'Regan PE No.58126
MiTek Inc. DBA MiTek USA FL Cert 6634
16023 Swingley Ridge Rd. Chesterfield, MO 63017
Date:

August 4, 2023

WARNING - Verify design parameters and READ NOTES ON THIS AND INCLUDED MITEK REFERENCE PAGE MII-7473 rev. 1/2/2023 BEFORE USE.

Design valid for use only with MiTek® connectors. This design is based only upon parameters shown, and is for an individual building component, not a truss system. Before use, the building designer must verify the applicability of design parameters and properly incorporate this design into the overall building design. Bracing indicated is to prevent buckling of individual truss web and/or chord members only. Additional temporary and permanent bracing is always required for stability and to prevent collapse with possible personal injury and property damage. For general guidance regarding the fabrication, storage, delivery, erection and bracing of trusses and truss systems, see **ANSI/TPI1 Quality Criteria and DSB-22** available from Truss Plate Institute (www.tpinst.org) and **BCSI Building Component Safety Information** available from the Structural Building Component Association (www.sbcsc.com)

MiTek®

16023 Swingley Ridge Rd.
Chesterfield, MO 63017
314.434.1200 / MiTek-US.com

Job 3626267	Truss HJ10	Truss Type DIAGONAL HIP GIRDER	Qty 1	Ply 1	JT BLDRS - LOT 12 CCP	T31220131
----------------	---------------	-----------------------------------	----------	----------	-----------------------	-----------

Builders FirstSource, Lake City, FL 32055

8.530 s May 26 2022 MiTek Industries, Inc. Fri Aug 4 10:50:38 2023 Page 1
ID:2eRY39KFhR2benj7cX?4RUzckGi-MmJBJco1yrmWoZDOnWDQTIgZz29d5arXkdkG3QsyrPzl

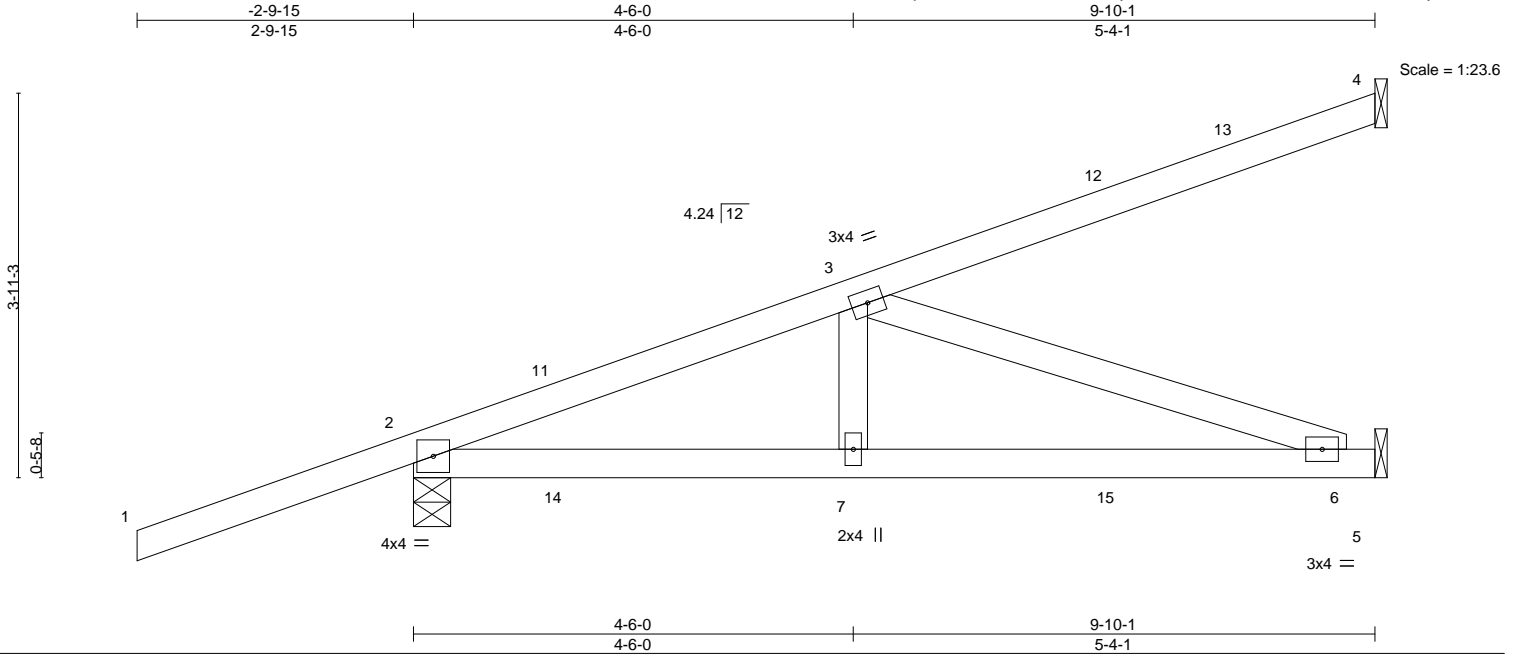

LOADING (psf)	SPACING-	CSI.	DEFL.	PLATES	GRIP
TCLL 20.0	2-0-0	TC 0.60	in (loc) l/defl L/d	MT20	244/190
TCDL 7.0	Plate Grip DOL 1.25	BC 0.61	Vert(LL) -0.05 6-7 >999 240		
BCLL 0.0 *	Lumber DOL 1.25	WB 0.33	Vert(CT) -0.12 6-7 >941 180		
BCDL 10.0	Rep Stress Incr NO	Matrix-MS	Horz(CT) -0.01 4 n/a n/a		
	Code FBC2020/TPI2014			Weight: 45 lb	FT = 20%

LUMBER-

TOP CHORD 2x4 SP No.2
BOT CHORD 2x4 SP No.2
WEBS 2x4 SP No.3

BRACING-

TOP CHORD Structural wood sheathing directly applied or 6-0-0 oc purlins.
BOT CHORD Rigid ceiling directly applied or 10-0-0 oc bracing.

REACTIONS.

(size) 4=Mechanical, 2=0-4-9, 5=Mechanical
Max Horz 2=155(LC 4)
Max Uplift 4=-78(LC 4), 2=-177(LC 4), 5=-46(LC 8)
Max Grav 4=152(LC 1), 2=462(LC 1), 5=265(LC 3)

FORCES. (lb) - Max. Comp./Max. Ten. - All forces 250 (lb) or less except when shown.

TOP CHORD 2-3=-592/149
BOT CHORD 2-7=-183/534, 6-7=-183/534
WEBS 3-6=-565/193

NOTES-

- 1) Wind: ASCE 7-16; Vult=130mph (3-second gust) Vasd=101mph; TCDL=4.2psf; BCDL=3.0psf; h=18ft; Cat. II; Exp B; Encl., GCpi=0.18; MWFRS (envelope) gable end zone; Lumber DOL=1.60 plate grip DOL=1.60
- 2) Building Designer / Project engineer responsible for verifying applied roof live load shown covers rain loading requirements specific to the use of this truss component.
- 3) This truss has been designed for a 10.0 psf bottom chord live load nonconcurrent with any other live loads.
- 4) * This truss has been designed for a live load of 20.0psf on the bottom chord in all areas where a rectangle 3-6-0 tall by 2-0-0 wide will fit between the bottom chord and any other members.
- 5) Refer to girder(s) for truss to truss connections.
- 6) Provide mechanical connection (by others) of truss to bearing plate capable of withstanding 78 lb uplift at joint 4, 177 lb uplift at joint 2 and 46 lb uplift at joint 5.
- 7) Hanger(s) or other connection device(s) shall be provided sufficient to support concentrated load(s) 54 lb down and 104 lb up at 1-6-1, 54 lb down and 104 lb up at 1-6-1, 19 lb down and 34 lb up at 4-4-0, 19 lb down and 34 lb up at 4-4-0, and 41 lb down and 75 lb up at 7-1-15, and 41 lb down and 75 lb up at 7-1-15 on top chord, and 18 lb down and 73 lb up at 1-6-1, 18 lb down and 73 lb up at 1-6-1, 24 lb down and 3 lb up at 4-4-0, 24 lb down and 3 lb up at 4-4-0, and 42 lb down at 7-1-15, and 42 lb down at 7-1-15 on bottom chord. The design/selection of such connection device(s) is the responsibility of others.
- 8) In the LOAD CASE(S) section, loads applied to the face of the truss are noted as front (F) or back (B).

LOAD CASE(S) Standard

- 1) Dead + Roof Live (balanced): Lumber Increase=1.25, Plate Increase=1.25
Uniform Loads (plf)
Vert: 1-4=-54, 5-8=-20
Concentrated Loads (lb)
Vert: 7=7(F=3, B=3) 11=51(F=26, B=26) 12=-66(F=-33, B=-33) 14=68(F=34, B=34) 15=-46(F=-23, B=-23)

This item has been electronically signed and sealed by O'Regan, Philip, PE using a Digital Signature. Printed copies of this document are not considered signed and sealed and the signature must be verified on any electronic copies.

Philip J. O'Regan PE No.58126
MiTek Inc. DBA MiTek USA FL Cert 6634
16023 Swingley Ridge Rd. Chesterfield, MO 63017
Date:

August 4, 2023

WARNING - Verify design parameters and READ NOTES ON THIS AND INCLUDED MITEK REFERENCE PAGE MII-7473 rev. 1/2/2023 BEFORE USE.

Design valid for use only with MiTek® connectors. This design is based only upon parameters shown, and is for an individual building component, not a truss system. Before use, the building designer must verify the applicability of design parameters and properly incorporate this design into the overall building design. Bracing indicated is to prevent buckling of individual truss web and/or chord members only. Additional temporary and permanent bracing is always required for stability and to prevent collapse with possible personal injury and property damage. For general guidance regarding the fabrication, storage, delivery, erection and bracing of trusses and truss systems, see **ANSI/TPI1 Quality Criteria and DSB-22** available from Truss Plate Institute (www.tpinst.org) and **BCSI Building Component Safety Information** available from the Structural Building Component Association (www.sbcsccomponents.com)

MiTek®

16023 Swingley Ridge Rd.
Chesterfield, MO 63017
314.434.1200 / MiTek-US.com

Job 3626267	Truss HJ10A	Truss Type Diagonal Hip Girder	Qty 1	Ply 1	JT BLDRS - LOT 12 CCP	T31220132
----------------	----------------	-----------------------------------	----------	----------	-----------------------	-----------

Builders FirstSource, Lake City, FL 32055

8.530 s May 26 2022 MiTek Industries, Inc. Fri Aug 4 10:50:39 2023 Page 1
ID:2eRY39KFhR2benj7cX?4RUzckGi-rztZXypfj9uNQjoaLEkf?wp9XZ_HJKKtsN?czlyrPzk

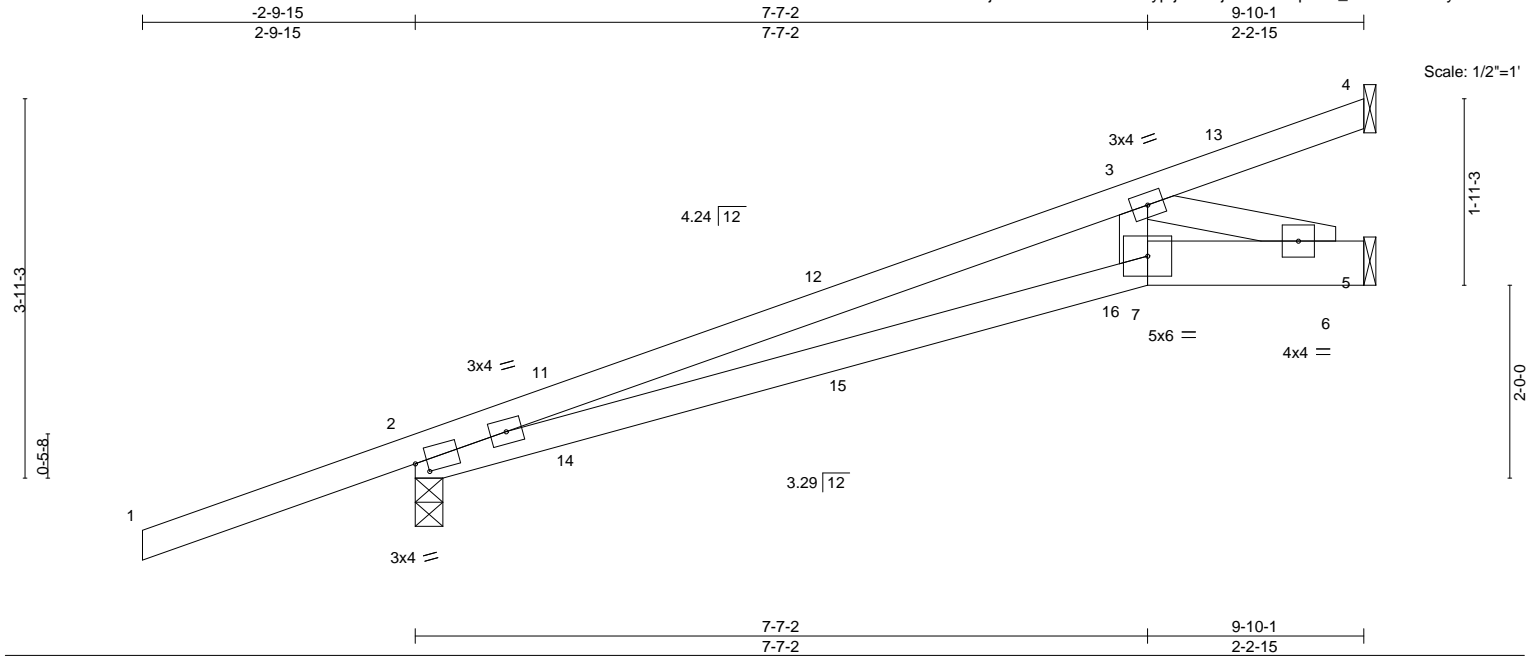

Plate Offsets (X,Y)--	[2:0-1-8,0-1-6]
-----------------------	-----------------

LOADING (psf)	SPACING-	CSI.	DEFL.	PLATES	GRIP
TCLL 20.0	Plate Grip DOL 1.25	TC 0.56	in (loc) l/defl L/d	MT20	244/190
TCDL 7.0	Lumber DOL 1.25	BC 0.55	Vert(LL) -0.09 7-10 >999 240		
BCLL 0.0 *	Rep Stress Incr NO	WB 0.23	Vert(CT) -0.15 7-10 >792 180		
BCDL 10.0	Code FBC2020/TPI2014	Matrix-MS	Horz(CT) 0.03 5 n/a n/a		
				Weight: 41 lb	FT = 20%

LUMBER-

TOP CHORD 2x4 SP No.2
 BOT CHORD 2x4 SP No.2 *Except*
 5-7: 2x6 SP No.2
 WEBS 2x4 SP No.3

BRACING-

TOP CHORD Structural wood sheathing directly applied or 5-1-2 oc purlins.
 BOT CHORD Rigid ceiling directly applied or 9-9-7 oc bracing.

REACTIONS.

(size) 4=Mechanical, 2=0-3-7, 5=Mechanical
 Max Horz 2=155(LC 4)
 Max Uplift 4=-17(LC 28), 2=-174(LC 4), 5=-125(LC 8)
 Max Grav 4=48(LC 19), 2=462(LC 1), 5=379(LC 1)

FORCES. (lb) - Max. Comp./Max. Ten. - All forces 250 (lb) or less except when shown.

TOP CHORD 2-3=-1108/316
 BOT CHORD 2-7=-364/1052, 6-7=-356/1065
 WEBS 3-7=-47/473, 3-6=-1124/375

NOTES-

- Wind: ASCE 7-16; Vult=130mph (3-second gust) Vasd=101mph; TCDL=4.2psf; BCDL=3.0psf; h=18ft; Cat. II; Exp B; Encl., GCpi=0.18; MWFRS (envelope) gable end zone; Lumber DOL=1.60 plate grip DOL=1.60
- Building Designer / Project engineer responsible for verifying applied roof live load shown covers rain loading requirements specific to the use of this truss component.
- This truss has been designed for a 10.0 psf bottom chord live load nonconcurrent with any other live loads.
- * This truss has been designed for a live load of 20.0psf on the bottom chord in all areas where a rectangle 3-6-0 tall by 2-0-0 wide will fit between the bottom chord and any other members.
- Refer to girder(s) for truss to truss connections.
- Bearing at joint(s) 2 considers parallel to grain value using ANSI/TPI 1 angle to grain formula. Building designer should verify capacity of bearing surface.
- Provide mechanical connection (by others) of truss to bearing plate capable of withstanding 17 lb uplift at joint 4, 174 lb uplift at joint 2 and 125 lb uplift at joint 5.
- Hanger(s) or other connection device(s) shall be provided sufficient to support concentrated load(s) 53 lb down and 105 lb up at 1-6-1, 53 lb down and 105 lb up at 1-6-1, 20 lb down and 33 lb up at 4-4-0, 20 lb down and 33 lb up at 4-4-0, and 41 lb down and 74 lb up at 7-1-15, and 41 lb down and 74 lb up at 7-1-15 on top chord, and 14 lb down and 72 lb up at 1-6-1, 14 lb down and 72 lb up at 1-6-1, 23 lb down and 2 lb up at 4-4-0, 23 lb down and 2 lb up at 4-4-0, and 41 lb down at 7-1-15, and 41 lb down at 7-1-15 on bottom chord. The design/selection of such connection device(s) is the responsibility of others.
- In the LOAD CASE(S) section, loads applied to the face of the truss are noted as front (F) or back (B).

LOAD CASE(S) Standard

- Dead + Roof Live (balanced): Lumber Increase=1.25, Plate Increase=1.25
 Uniform Loads (plf)
 Vert: 1-4=-54, 7-8=-20, 5-7=-20

This item has been electronically signed and sealed by O'Regan, Philip, PE using a Digital Signature. Printed copies of this document are not considered signed and sealed and the signature must be verified on any electronic copies.

Philip J. O'Regan PE No.58126
 MiTek Inc. DBA MiTek USA FL Cert 6634
 16023 Swingley Ridge Rd. Chesterfield, MO 63017
 Date:

August 4, 2023

Continued on page 2

WARNING - Verify design parameters and READ NOTES ON THIS AND INCLUDED MITEK REFERENCE PAGE MII-7473 rev. 1/2/2023 BEFORE USE.

Design valid for use only with MiTek® connectors. This design is based only upon parameters shown, and is for an individual building component, not a truss system. Before use, the building designer must verify the applicability of design parameters and properly incorporate this design into the overall building design. Bracing indicated is to prevent buckling of individual truss web and/or chord members only. Additional temporary and permanent bracing is always required for stability and to prevent collapse with possible personal injury and property damage. For general guidance regarding the fabrication, storage, delivery, erection and bracing of trusses and truss systems, see **ANSI/TPI1 Quality Criteria and DSB-22** available from Truss Plate Institute (www.tpinst.org) and **BCSI Building Component Safety Information** available from the Structural Building Component Association (www.sbcsccomponents.com)

MiTek®

16023 Swingley Ridge Rd.
 Chesterfield, MO 63017
 314.434.1200 / MiTek-US.com

Job 3626267	Truss HJ10A	Truss Type Diagonal Hip Girder	Qty 1	Ply 1	JT BLDRS - LOT 12 CCP Job Reference (optional)	T31220132
----------------	----------------	-----------------------------------	----------	----------	---	-----------

Builders FirstSource, Lake City, FL 32055

8.530 s May 26 2022 MiTek Industries, Inc. Fri Aug 4 10:50:39 2023 Page 2
ID:2eRY39KFhR2benj7cX?4RUzckGi-rztZXypfj9uNQjoaLEkf?wp9XZ_HJKKtsN?czlyrPzk

LOAD CASE(S) Standard

Concentrated Loads (lb)

Vert: 3=-63(F=-32, B=-32) 11=50(F=25, B=25) 14=69(F=35, B=35) 15=4(F=2, B=2) 16=-49(F=-24, B=-24)

WARNING - Verify design parameters and READ NOTES ON THIS AND INCLUDED MITEK REFERENCE PAGE MII-7473 rev. 1/2/2023 BEFORE USE.

Design valid for use only with MiTek® connectors. This design is based only upon parameters shown, and is for an individual building component, not a truss system. Before use, the building designer must verify the applicability of design parameters and properly incorporate this design into the overall building design. Bracing indicated is to prevent buckling of individual truss web and/or chord members only. Additional temporary and permanent bracing is always required for stability and to prevent collapse with possible personal injury and property damage. For general guidance regarding the fabrication, storage, delivery, erection and bracing of trusses and truss systems, see **ANSI/TPI1 Quality Criteria and DSB-22** available from Truss Plate Institute (www.tpinst.org) and **BCSI Building Component Safety Information** available from the Structural Building Component Association (www.sbcsccomponents.com)

MiTek®

16023 Swingley Ridge Rd.
Chesterfield, MO 63017
314.434.1200 / MiTek-US.com

Job 3626267	Truss T01	Truss Type COMMON	Qty 4	Ply 1	JT BLDRS - LOT 12 CCP	T31220133
----------------	--------------	----------------------	----------	----------	-----------------------	-----------

Builders FirstSource, Lake City, FL 32055

8.530 s May 26 2022 MiTek Industries, Inc. Fri Aug 4 10:50:40 2023 Page 1
ID:2eRY39KFhR2benj7cX?4RUzckGi-J9RxlqHUSOE1tNnuxFuY7MM?zDy2nD051IAVkyrPzj

Job Reference (optional)

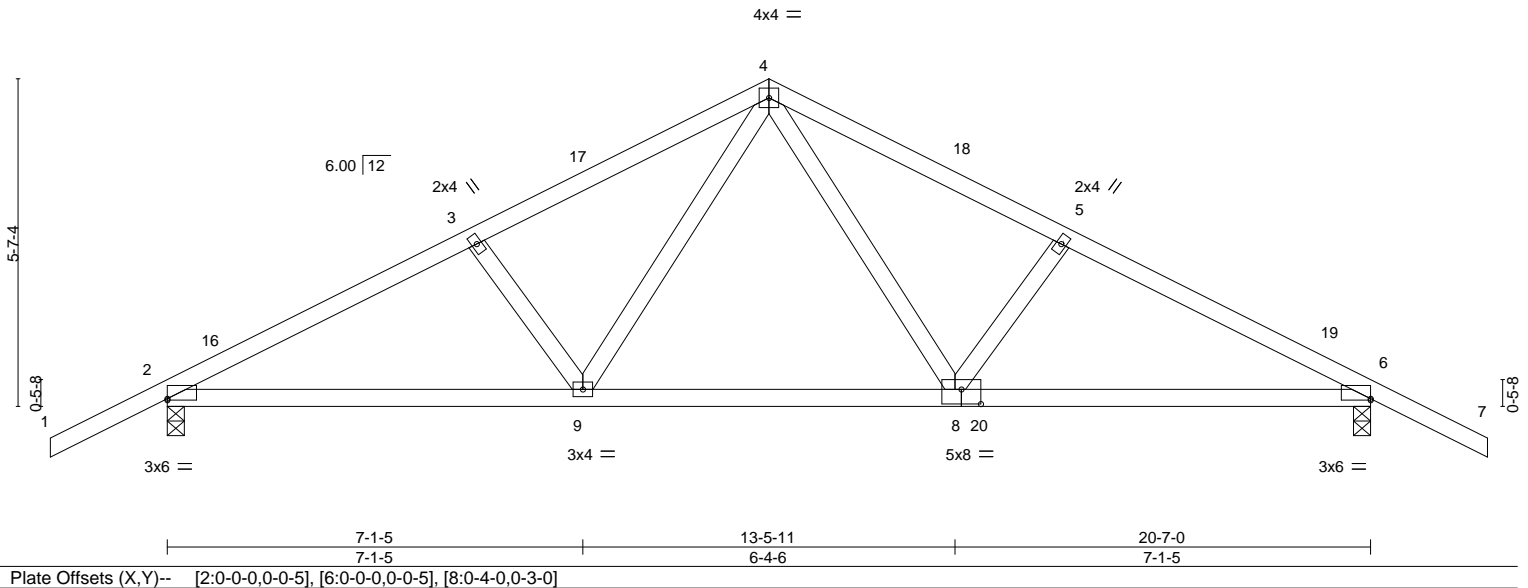
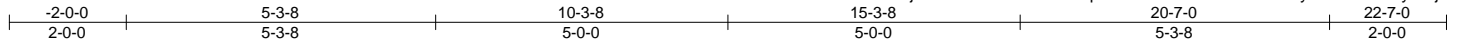

Plate Offsets (X,Y)--	[2:0-0,0,0-5], [6:0-0,0,0-5], [8:0-4-0,0,3-0]
-----------------------	---

LOADING (psf)	SPACING-	2-0-0	CSI.	DEFL.	in (loc)	l/defl	L/d	PLATES	GRIP
TCLL 20.0	Plate Grip DOL	1.25	TC 0.45	Vert(LL)	-0.17	8-9	>999	MT20	244/190
TCDL 7.0	Lumber DOL	1.25	BC 0.90	Vert(CT)	-0.32	8-9	>782		
BCLL 0.0 *	Rep Stress Incr	NO	WB 0.25	Horz(CT)	0.04	6	n/a		
BCDL 10.0	Code	FBC2020/TPI2014	Matrix-MS					Weight: 99 lb	FT = 20%

LUMBER-
TOP CHORD 2x4 SP No.2
BOT CHORD 2x4 SP No.2
WEBS 2x4 SP No.3

BRACING-
TOP CHORD Structural wood sheathing directly applied or 4-1-11 oc purlins.
BOT CHORD Rigid ceiling directly applied or 10-0-0 oc bracing.

REACTIONS. (size) 2=0-3-8, 6=0-3-8
Max Horz 2=-89(LC 13)
Max Uplift 2=-242(LC 12), 6=-244(LC 13)
Max Grav 2=1069(LC 1), 6=1078(LC 1)

FORCES. (lb) - Max. Comp./Max. Ten. - All forces 250 (lb) or less except when shown.
TOP CHORD 2-3=-1706/458, 3-4=-1557/457, 4-5=-1583/466, 5-6=-1726/463
BOT CHORD 2-9=-323/1465, 8-9=-162/1020, 6-8=-333/1482
WEBS 4-8=-178/657, 4-9=-167/628

- NOTES-**
- Unbalanced roof live loads have been considered for this design.
 - Wind: ASCE 7-16; Vult=130mph (3-second gust) Vasd=101mph; TCDL=4.2psf; BCDL=3.0psf; h=18ft; Cat. II; Exp B; Encl., GCpi=0.18; MWFRS (envelope) gable end zone and C-C Exterior(2E) -2-0-0 to 1-0-0, Interior(1) 1-0-0 to 10-3-8, Exterior(2R) 10-3-8 to 13-3-8, Interior(1) 13-3-8 to 22-7-0 zone; C-C for members and forces & MWFRS for reactions shown; Lumber DOL=1.60 plate grip DOL=1.60
 - Building Designer / Project engineer responsible for verifying applied roof live load shown covers rain loading requirements specific to the use of this truss component.
 - This truss has been designed for a 10.0 psf bottom chord live load nonconcurrent with any other live loads.
 - * This truss has been designed for a live load of 20.0psf on the bottom chord in all areas where a rectangle 3-6-0 tall by 2-0-0 wide will fit between the bottom chord and any other members.
 - Provide mechanical connection (by others) of truss to bearing plate capable of withstanding 242 lb uplift at joint 2 and 244 lb uplift at joint 6.
 - In the LOAD CASE(S) section, loads applied to the face of the truss are noted as front (F) or back (B).

LOAD CASE(S) Standard
1) Dead + Roof Live (balanced): Lumber Increase=1.25, Plate Increase=1.25
Uniform Loads (plf)
Vert: 1-4=-54, 4-7=-54, 9-10=-20, 9-20=-80(F=-60), 13-20=-20

This item has been electronically signed and sealed by O'Regan, Philip, PE using a Digital Signature. Printed copies of this document are not considered signed and sealed and the signature must be verified on any electronic copies.

Philip J. O'Regan PE No.58126
MiTek Inc. DBA MiTek USA FL Cert 6634
16023 Swingley Ridge Rd. Chesterfield, MO 63017
Date:

August 4, 2023

WARNING - Verify design parameters and READ NOTES ON THIS AND INCLUDED MITEK REFERENCE PAGE MII-7473 rev. 1/2/2023 BEFORE USE.

Design valid for use only with MiTek® connectors. This design is based only upon parameters shown, and is for an individual building component, not a truss system. Before use, the building designer must verify the applicability of design parameters and properly incorporate this design into the overall building design. Bracing indicated is to prevent buckling of individual truss web and/or chord members only. Additional temporary and permanent bracing is always required for stability and to prevent collapse with possible personal injury and property damage. For general guidance regarding the fabrication, storage, delivery, erection and bracing of trusses and truss systems, see **ANSI/TPI1 Quality Criteria and DSB-22** available from Truss Plate Institute (www.tpinst.org) and **BCSI Building Component Safety Information** available from the Structural Building Component Association (www.sbcsccomponents.com)

MiTek®

16023 Swingley Ridge Rd.
Chesterfield, MO 63017
314.434.1200 / MiTek-US.com

Job 3626267	Truss T01G	Truss Type COMMON SUPPORTED GAB	Qty 1	Ply 1	JT BLDRS - LOT 12 CCP	T31220134
----------------	---------------	------------------------------------	----------	----------	-----------------------	-----------

Builders FirstSource, Lake City, FL 32055

8.530 s May 26 2022 MiTek Industries, Inc. Fri Aug 4 10:50:41 2023 Page 1

ID:2eRY39KFhR2benj7cx?4RUzckGi-nL_JyeqvFm85f0yzSfm75LuawNlnHcAJhUj1AyrPzi
20-7-0 22-7-0
10-3-8 2-0-0

Scale = 1:40.7

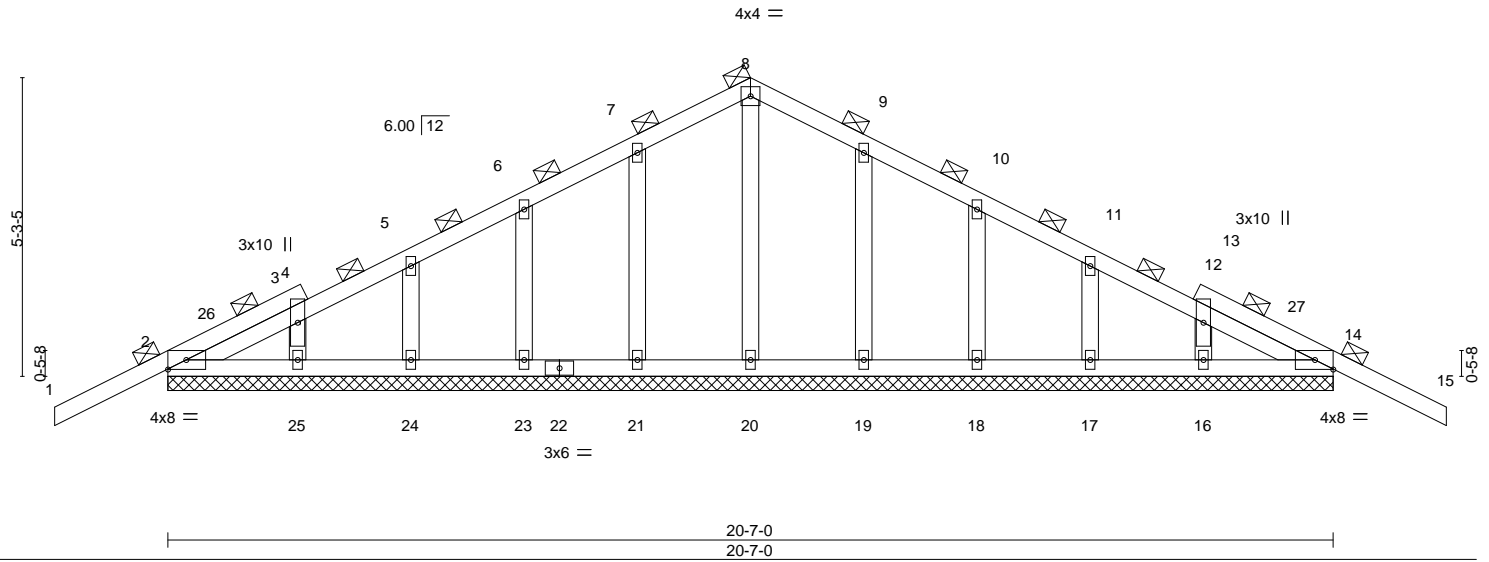

LOADING (psf)	SPACING-	CSI.	DEFL.	in (loc)	l/defl	L/d	PLATES	GRIP
TCLL 20.0	Plate Grip DOL 1.25	TC 0.24	Vert(LL) -0.02	15	n/r	120	MT20	244/190
TCDL 7.0	Lumber DOL 1.25	BC 0.04	Vert(CT) -0.03	15	n/r	120		
BCLL 0.0 *	Rep Stress Incr YES	WB 0.05	Horz(CT) 0.00	14	n/a	n/a		
BCDL 10.0	Code FBC2020/TPI2014	Matrix-S						
							Weight: 112 lb	FT = 20%

LUMBER-

TOP CHORD 2x4 SP No.2
BOT CHORD 2x4 SP No.2
OTHERS 2x4 SP No.3

BRACING-

TOP CHORD 2-0-0 oc purlins (6-0-0 max.).
BOT CHORD Rigid ceiling directly applied or 10-0-0 oc bracing.

REACTIONS.

All bearings 20-7-0.
(lb) - Max Horz 2=-84(LC 13)
Max Uplift All uplift 100 lb or less at joint(s) 2, 14, 21, 23, 24, 25, 19, 18, 17, 16
Max Grav All reactions 250 lb or less at joint(s) 2, 14, 20, 21, 23, 24, 25, 19, 18, 17, 16

FORCES. (lb) - Max. Comp./Max. Ten. - All forces 250 (lb) or less except when shown.

NOTES-

- Unbalanced roof live loads have been considered for this design.
- Wind: ASCE 7-16; Vult=130mph (3-second gust) Vasd=101mph; TC DL=4.2psf; BCDL=3.0psf; h=18ft; Cat. II; Exp B; Encl., GCpi=0.18; MWFRS (envelope) gable end zone and C-C Corner(3E) -2-0-0 to 1-0-0, Exterior(2N) 1-0-0 to 10-3-8, Corner(3R) 10-3-8 to 13-3-8, Exterior(2N) 13-3-8 to 22-7-0 zone; C-C for members and forces & MWFRS for reactions shown; Lumber DOL=1.60 plate grip DOL=1.60
- Truss designed for wind loads in the plane of the truss only. For studs exposed to wind (normal to the face), see Standard Industry Gable End Details as applicable, or consult qualified building designer as per ANSI/TPI 1.
- Building Designer / Project engineer responsible for verifying applied roof live load shown covers rain loading requirements specific to the use of this truss component.
- All plates are 2x4 MT20 unless otherwise indicated.
- Gable requires continuous bottom chord bearing.
- Gable studs spaced at 2-0-0 oc.
- This truss has been designed for a 10.0 psf bottom chord live load nonconcurrent with any other live loads.
- * This truss has been designed for a live load of 20.0psf on the bottom chord in all areas where a rectangle 3-6-0 tall by 2-0-0 wide will fit between the bottom chord and any other members.
- Provide mechanical connection (by others) of truss to bearing plate capable of withstanding 100 lb uplift at joint(s) 2, 14, 21, 23, 24, 25, 19, 18, 17, 16.
- Graphical purlin representation does not depict the size or the orientation of the purlin along the top and/or bottom chord.

This item has been electronically signed and sealed by O'Regan, Philip, PE using a Digital Signature. Printed copies of this document are not considered signed and sealed and the signature must be verified on any electronic copies.

Philip J. O'Regan PE No.58126
MiTek Inc. DBA MiTek USA FL Cert 6634
16023 Swingley Ridge Rd. Chesterfield, MO 63017
Date:

August 4, 2023

WARNING - Verify design parameters and READ NOTES ON THIS AND INCLUDED MITEK REFERENCE PAGE MII-7473 rev. 1/2/2023 BEFORE USE.

Design valid for use only with MiTek® connectors. This design is based only upon parameters shown, and is for an individual building component, not a truss system. Before use, the building designer must verify the applicability of design parameters and properly incorporate this design into the overall building design. Bracing indicated is to prevent buckling of individual truss web and/or chord members only. Additional temporary and permanent bracing is always required for stability and to prevent collapse with possible personal injury and property damage. For general guidance regarding the fabrication, storage, delivery, erection and bracing of trusses and truss systems, see **ANSI/TPI1 Quality Criteria and DSB-22** available from Truss Plate Institute (www.tpinst.org) and **BCSI Building Component Safety Information** available from the Structural Building Component Association (www.sbcsccomponents.com)

MiTek®

16023 Swingley Ridge Rd.
Chesterfield, MO 63017
314.434.1200 / MiTek-US.com

Job 3626267	Truss T02	Truss Type COMMON	Qty 3	Ply 1	JT BLDRS - LOT 12 CCP	T31220135
----------------	--------------	----------------------	----------	----------	-----------------------	-----------

Builders FirstSource, Lake City, FL 32055

8.530 s May 26 2022 MiTek Industries, Inc. Fri Aug 4 10:50:41 2023 Page 1
ID:2eRY39KFhR2benj7cX?4RUzckGi-nL_yeqvFm85f0yzSfm75LuXqNaNnETAJhUj1AyrPzi



Scale = 1:36.9

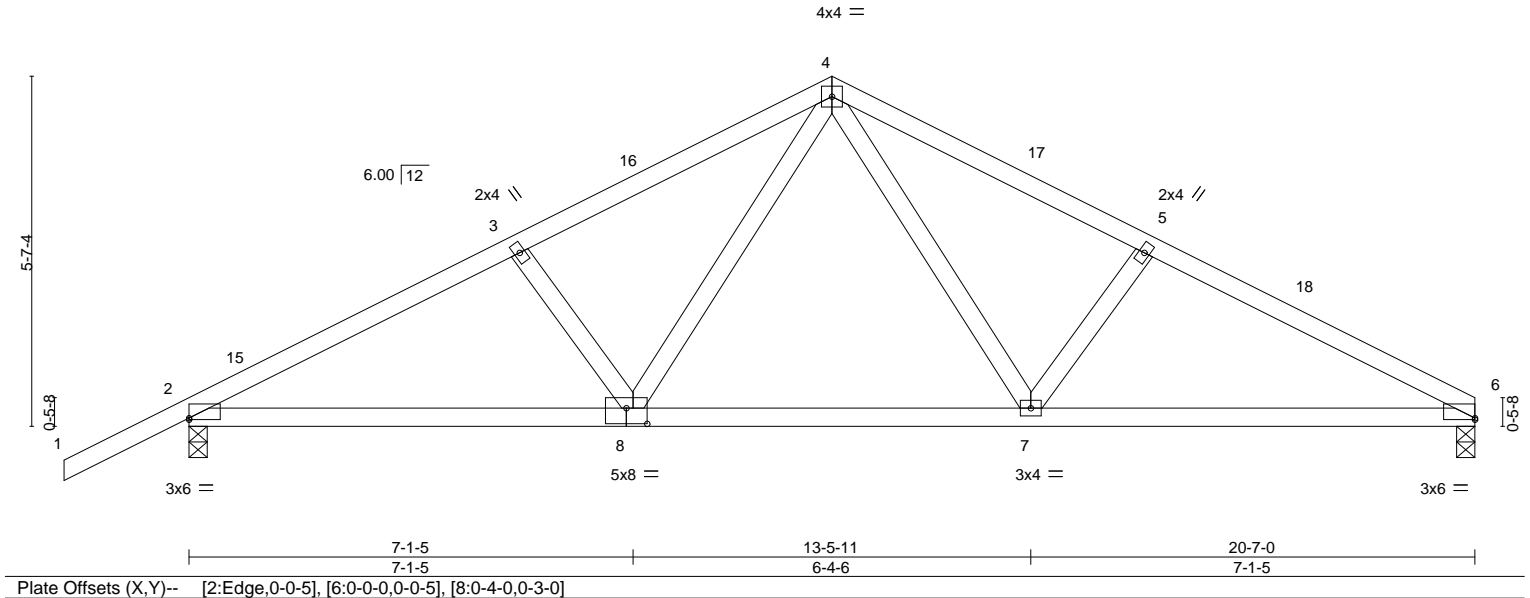

LOADING (psf)	SPACING-	2-0-0	CSI.	DEFL.	in (loc)	l/defl	L/d	PLATES	GRIP
TCLL 20.0	Plate Grip DOL	1.25	TC 0.44	Vert(LL)	-0.16	7-8	>999	240	244/190
TCDL 7.0	Lumber DOL	1.25	BC 0.89	Vert(CT)	-0.31	7-8	>802	180	
BCLL 0.0 *	Rep Stress Incr	NO	WB 0.25	Horz(CT)	0.04	6	n/a	n/a	
BCDL 10.0	Code	FBC2020/TPI2014	Matrix-MS						
								Weight: 95 lb	FT = 20%

LUMBER-

TOP CHORD 2x4 SP No.2
BOT CHORD 2x4 SP No.2
WEBS 2x4 SP No.3

BRACING-

TOP CHORD Structural wood sheathing directly applied or 4-2-1 oc purlins.
BOT CHORD Rigid ceiling directly applied or 9-6-15 oc bracing.

REACTIONS.

(size) 6=0-3-8, 2=0-3-8
Max Horz 2=103(LC 16)
Max Uplift 6=197(LC 13), 2=242(LC 12)
Max Grav 6=950(LC 1), 2=1070(LC 1)

FORCES. (lb) - Max. Comp./Max. Ten. - All forces 250 (lb) or less except when shown.

TOP CHORD 2-3=-1710/467, 3-4=-1566/470, 4-5=-1573/478, 5-6=-1725/479
BOT CHORD 2-8=-368/1468, 7-8=-202/1019, 6-7=-372/1487
WEBS 4-7=-179/657, 5-7=-253/161, 4-8=-168/635

NOTES-

- Unbalanced roof live loads have been considered for this design.
- Wind: ASCE 7-16; Vult=130mph (3-second gust) Vasd=101mph; TCdL=4.2psf; BCDL=3.0psf; h=18ft; Cat. II; Exp B; Encl., GCpi=0.18; MWFRS (envelope) gable end zone and C-C Exterior(2E) -2-0-0 to 1-0-0, Interior(1) 1-0-0 to 10-3-8, Exterior(2R) 10-3-8 to 13-3-8, Interior(1) 13-3-8 to 20-7-0 zone; C-C for members and forces & MWFRS for reactions shown; Lumber DOL=1.60 plate grip DOL=1.60
- Building Designer / Project engineer responsible for verifying applied roof live load shown covers rain loading requirements specific to the use of this truss component.
- This truss has been designed for a 10.0 psf bottom chord live load nonconcurrent with any other live loads.
- * This truss has been designed for a live load of 20.0psf on the bottom chord in all areas where a rectangle 3-6-0 tall by 2-0-0 wide will fit between the bottom chord and any other members.
- Provide mechanical connection (by others) of truss to bearing plate capable of withstanding 100 lb uplift at joint(s) except (jt=lb) 6=197, 2=242.
- In the LOAD CASE(S) section, loads applied to the face of the truss are noted as front (F) or back (B).

LOAD CASE(S) Standard

- Dead + Roof Live (balanced): Lumber Increase=1.25, Plate Increase=1.25
Uniform Loads (plf)
Vert: 1-4=-54, 4-6=-54, 8-12=-20, 7-8=-80(F=-60), 7-9=-20

This item has been electronically signed and sealed by O'Regan, Philip, PE using a Digital Signature. Printed copies of this document are not considered signed and sealed and the signature must be verified on any electronic copies.

Philip J. O'Regan PE No.58126
MiTek Inc. DBA MiTek USA FL Cert 6634
16023 Swingley Ridge Rd. Chesterfield, MO 63017
Date:

August 4, 2023

WARNING - Verify design parameters and READ NOTES ON THIS AND INCLUDED MITEK REFERENCE PAGE MII-7473 rev. 1/2/2023 BEFORE USE.

Design valid for use only with MiTek® connectors. This design is based only upon parameters shown, and is for an individual building component, not a truss system. Before use, the building designer must verify the applicability of design parameters and properly incorporate this design into the overall building design. Bracing indicated is to prevent buckling of individual truss web and/or chord members only. Additional temporary and permanent bracing is always required for stability and to prevent collapse with possible personal injury and property damage. For general guidance regarding the fabrication, storage, delivery, erection and bracing of trusses and truss systems, see **ANSI/TPI1 Quality Criteria and DSB-22** available from Truss Plate Institute (www.tpinst.org) and **BCSI Building Component Safety Information** available from the Structural Building Component Association (www.sbcsccomponents.com)

MiTek®

16023 Swingley Ridge Rd.
Chesterfield, MO 63017
314.434.1200 / MiTek-US.com

Job 3626267	Truss T03	Truss Type COMMON	Qty 4	Ply 1	JT BLDRS - LOT 12 CCP	T31220136
----------------	--------------	----------------------	----------	----------	-----------------------	-----------

Builders FirstSource, Lake City, FL 32055

ID:2eRY39KFhR2benj7cX?4RUzckGi-FXYi9_rX04GxHAX90MHMdYRigmwxWheJYLEHZdyrPzh
8.530 s May 26 2022 MiTek Industries, Inc. Fri Aug 4 10:50:42 2023 Page 1

Job Reference (optional)

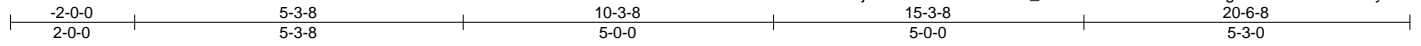

Scale = 1:37.1

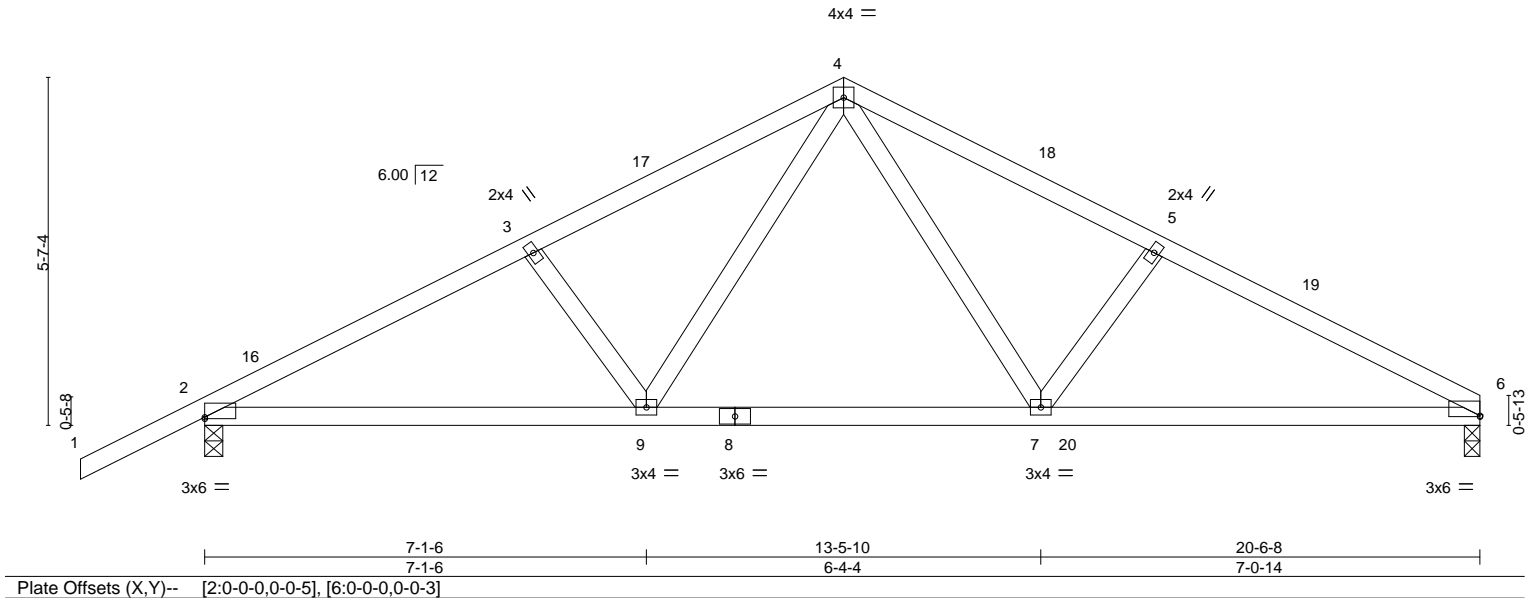

LOADING (psf)	SPACING-	2-0-0	CSI.	DEFL.	in (loc)	l/defl	L/d	PLATES	GRIP
TCLL 20.0	Plate Grip DOL	1.25	TC 0.43	Vert(LL)	-0.16	7-9	>999	MT20	244/190
TCDL 7.0	Lumber DOL	1.25	BC 0.87	Vert(CT)	-0.30	7-9	>831		
BCLL 0.0 *	Rep Stress Incr	NO	WB 0.26	Horz(CT)	0.04	6	n/a		
BCDL 10.0	Code	FBC2020/TPI2014	Matrix-MS					Weight: 95 lb	FT = 20%

LUMBER-

TOP CHORD 2x4 SP No.2
BOT CHORD 2x4 SP No.2
WEBS 2x4 SP No.3

BRACING-

TOP CHORD Structural wood sheathing directly applied or 4-2-2 oc purlins.
BOT CHORD Rigid ceiling directly applied or 9-5-14 oc bracing.

REACTIONS.

(size) 6=0-3-0, 2=0-3-8
Max Horz 2=103(LC 12)
Max Uplift 6=-201(LC 13), 2=-242(LC 12)
Max Grav 6=964(LC 1), 2=1073(LC 1)

FORCES. (lb) - Max. Comp./Max. Ten. - All forces 250 (lb) or less except when shown.

TOP CHORD 2-3=-1711/470, 3-4=-1561/468, 4-5=-1590/485, 5-6=-1741/486
BOT CHORD 2-9=-371/1469, 7-9=-206/1029, 6-7=-379/1499
WEBS 4-7=-185/670, 4-9=-163/621

NOTES-

- Unbalanced roof live loads have been considered for this design.
- Wind: ASCE 7-16; Vult=130mph (3-second gust) Vasd=101mph; TCDL=4.2psf; BCDL=3.0psf; h=18ft; Cat. II; Exp B; Encl., GCpi=0.18; MWFRS (envelope) gable end zone and C-C Exterior(2E) -2-0-0 to 1-0-0, Interior(1) 1-0-0 to 10-3-8, Exterior(2R) 10-3-8 to 13-3-8, Interior(1) 13-3-8 to 20-6-8 zone; C-C for members and forces & MWFRS for reactions shown; Lumber DOL=1.60 plate grip DOL=1.60
- Building Designer / Project engineer responsible for verifying applied roof live load shown covers rain loading requirements specific to the use of this truss component.
- This truss has been designed for a 10.0 psf bottom chord live load nonconcurrent with any other live loads.
- * This truss has been designed for a live load of 20.0psf on the bottom chord in all areas where a rectangle 3-6-0 tall by 2-0-0 wide will fit between the bottom chord and any other members.
- Provide mechanical connection (by others) of truss to bearing plate capable of withstanding 100 lb uplift at joint(s) except (jt=lb) 6=201, 2=242.
- In the LOAD CASE(S) section, loads applied to the face of the truss are noted as front (F) or back (B).

LOAD CASE(S) Standard

- Dead + Roof Live (balanced): Lumber Increase=1.25, Plate Increase=1.25
Uniform Loads (plf)
Vert: 1-4=-54, 4-6=-54, 9-13=-20, 9-20=-80(F=-60), 10-20=-20

This item has been electronically signed and sealed by ORegan, Philip, PE using a Digital Signature. Printed copies of this document are not considered signed and sealed and the signature must be verified on any electronic copies.

Philip J. O'Regan PE No.58126
MiTek Inc. DBA MiTek USA FL Cert 6634
16023 Swingley Ridge Rd. Chesterfield, MO 63017
Date:

August 4, 2023

WARNING - Verify design parameters and READ NOTES ON THIS AND INCLUDED MITEK REFERENCE PAGE MII-7473 rev. 1/2/2023 BEFORE USE.

Design valid for use only with MiTek® connectors. This design is based only upon parameters shown, and is for an individual building component, not a truss system. Before use, the building designer must verify the applicability of design parameters and properly incorporate this design into the overall building design. Bracing indicated is to prevent buckling of individual truss web and/or chord members only. Additional temporary and permanent bracing is always required for stability and to prevent collapse with possible personal injury and property damage. For general guidance regarding the fabrication, storage, delivery, erection and bracing of trusses and truss systems, see **ANSI/TPI1 Quality Criteria and DSB-22** available from Truss Plate Institute (www.tpinst.org) and **BCSI Building Component Safety Information** available from the Structural Building Component Association (www.sbcsccomponents.com)

MiTek®

16023 Swingley Ridge Rd.
Chesterfield, MO 63017
314.434.1200 / MiTek-US.com

Job 3626267	Truss T04	Truss Type COMMON	Qty 2	Ply 1	JT BLDRS - LOT 12 CCP	T31220137
----------------	--------------	----------------------	----------	----------	-----------------------	-----------

Builders FirstSource, Lake City, FL 32055

ID:2eRY39KFhR2benj7cX?4RUzckGi-FXYi9_rX04GxHAX90MHMdyRj2m2?Wj3JYLEHZdyrPzh
8.530 s May 26 2022 MiTek Industries, Inc. Fri Aug 4 10:50:42 2023 Page 1

Job Reference (optional)

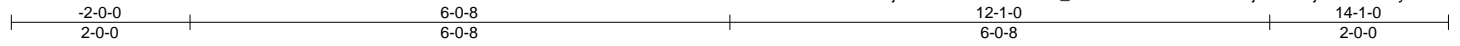

Scale = 1:25.8

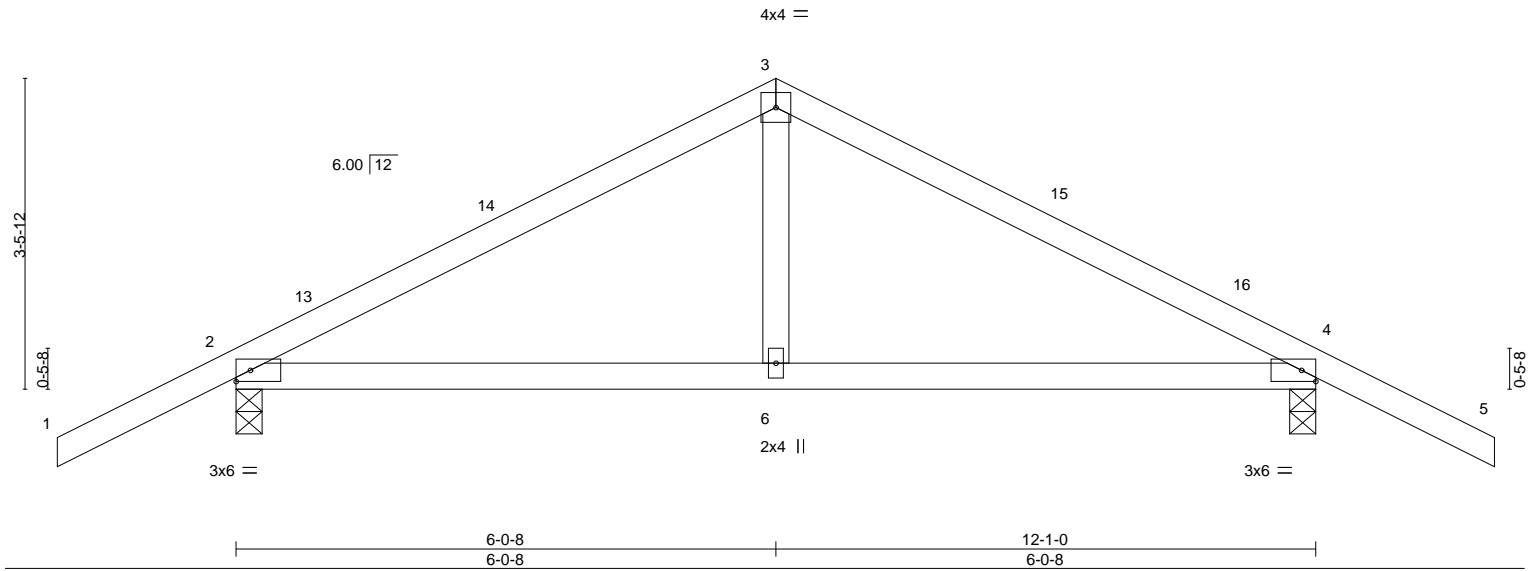

LOADING (psf)	SPACING-	CSI.	DEFL.	in (loc)	I/defl	L/d	PLATES	GRIP
TCLL 20.0	2-0-0	TC 0.35	Vert(LL)	-0.02	6-12	>999	MT20	244/190
TCDL 7.0	Plate Grip DOL 1.25	BC 0.35	Vert(CT)	-0.05	6-12	>999		
BCLL 0.0 *	Lumber DOL 1.25	WB 0.10	Horz(CT)	0.01	4	n/a		
BCDL 10.0	Rep Stress Incr YES	Matrix-MS						
	Code FBC2020/TPI2014						Weight: 49 lb	FT = 20%

LUMBER-

TOP CHORD 2x4 SP No.2
BOT CHORD 2x4 SP No.2
WEBS 2x4 SP No.3

BRACING-

TOP CHORD Structural wood sheathing directly applied or 6-0-0 oc purlins.
BOT CHORD Rigid ceiling directly applied or 10-0-0 oc bracing.

REACTIONS.

(size) 2=0-3-8, 4=0-3-8
Max Horz 2=-58(LC 13)
Max Uplift 2=-130(LC 12), 4=-130(LC 13)
Max Grav 2=555(LC 1), 4=555(LC 1)

FORCES. (lb) - Max. Comp./Max. Ten. - All forces 250 (lb) or less except when shown.

TOP CHORD 2-3=-573/209, 3-4=-573/209
BOT CHORD 2-6=-59/448, 4-6=-59/448
WEBS 3-6=0/263

NOTES-

- Unbalanced roof live loads have been considered for this design.
- Wind: ASCE 7-16; Vult=130mph (3-second gust) Vasd=101mph; TCDL=4.2psf; BCDL=3.0psf; h=18ft; Cat. II; Exp B; Encl., GCpi=0.18; MWFRS (envelope) gable end zone and C-C Exterior(2E) -2-0-0 to 1-0-0, Interior(1) 1-0-0 to 6-0-8, Exterior(2R) 6-0-8 to 9-0-8, Interior(1) 9-0-8 to 14-1-0 zone; C-C for members and forces & MWFRS for reactions shown; Lumber DOL=1.60 plate grip DOL=1.60
- Building Designer / Project engineer responsible for verifying applied roof live load shown covers rain loading requirements specific to the use of this truss component.
- This truss has been designed for a 10.0 psf bottom chord live load nonconcurrent with any other live loads.
- * This truss has been designed for a live load of 20.0psf on the bottom chord in all areas where a rectangle 3-6-0 tall by 2-0-0 wide will fit between the bottom chord and any other members.
- Provide mechanical connection (by others) of truss to bearing plate capable of withstanding 100 lb uplift at joint(s) except (jt=lb) 2=130, 4=130.

This item has been electronically signed and sealed by ORegan, Philip, PE using a Digital Signature. Printed copies of this document are not considered signed and sealed and the signature must be verified on any electronic copies.

Philip J. O'Regan PE No.58126
MiTek Inc. DBA MiTek USA FL Cert 6634
16023 Swingley Ridge Rd. Chesterfield, MO 63017
Date:

August 4, 2023

WARNING - Verify design parameters and READ NOTES ON THIS AND INCLUDED MITEK REFERENCE PAGE MII-7473 rev. 1/2/2023 BEFORE USE.

Design valid for use only with MiTek® connectors. This design is based only upon parameters shown, and is for an individual building component, not a truss system. Before use, the building designer must verify the applicability of design parameters and properly incorporate this design into the overall building design. Bracing indicated is to prevent buckling of individual truss web and/or chord members only. Additional temporary and permanent bracing is always required for stability and to prevent collapse with possible personal injury and property damage. For general guidance regarding the fabrication, storage, delivery, erection and bracing of trusses and truss systems, see **ANSI/TPI1 Quality Criteria and DSB-22** available from Truss Plate Institute (www.tpinst.org) and **BCSI Building Component Safety Information** available from the Structural Building Component Association (www.sbcsccomponents.com)

MiTek®

16023 Swingley Ridge Rd.
Chesterfield, MO 63017
314.434.1200 / MiTek-US.com

Job 3626267	Truss T04G	Truss Type COMMON SUPPORTED GAB	Qty 1	Ply 1	JT BLDRS - LOT 12 CCP	T31220138
Builders FirstSource, Lake City, FL 32055					Job Reference (optional)	

8.530 s May 26 2022 MiTek Industries, Inc. Fri Aug 4 10:50:43 2023 Page 1
 ID:2eRY39KFhR2benj7cX?4RUzckGi-jk64NJs9nNOouK6Ma4pbAmzwPATEFBJTn?zq63yrPzg

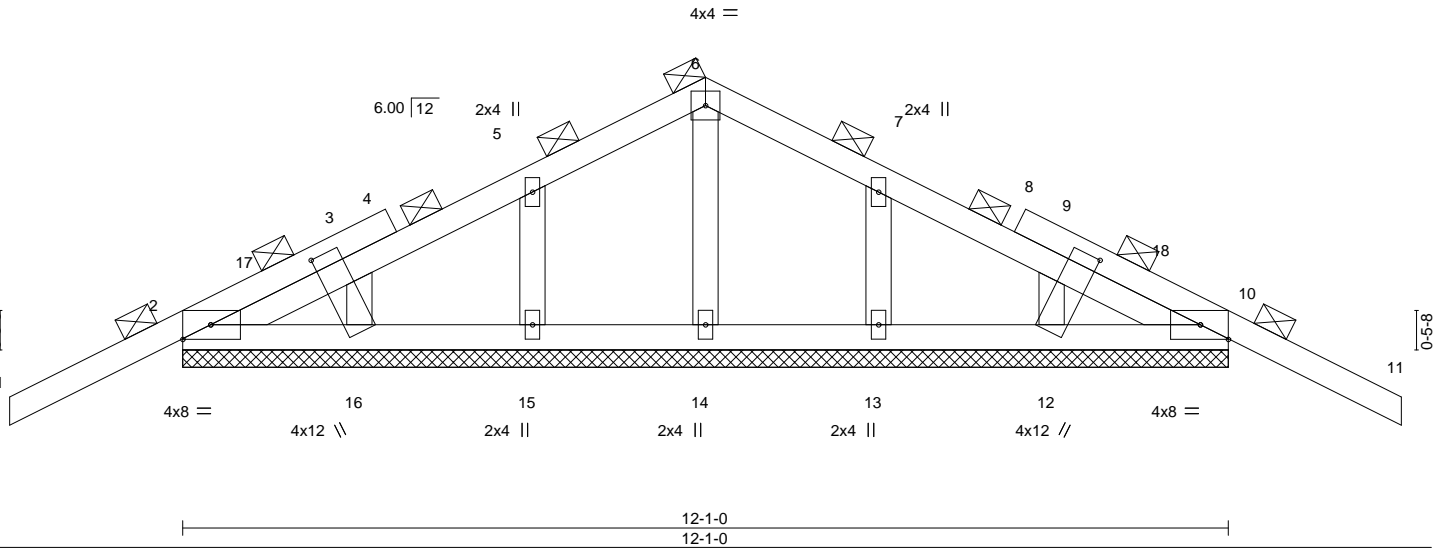
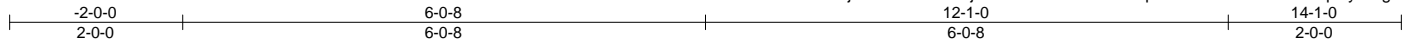

Plate Offsets (X,Y)--	[12:0-1-12,1-4-7], [16:0-1-12,1-4-7]								
LOADING (psf)	SPACING-	2-0-0	CSI.	DEFL.	in (loc)	l/defl	L/d	PLATES	GRIP
TCLL 20.0	Plate Grip DOL 1.25		TC 0.24	Vert(LL) -0.02	11	n/r	120	MT20	244/190
TCDL 7.0	Lumber DOL 1.25		BC 0.03	Vert(CT) -0.03	11	n/r	120		
BCLL 0.0 *	Rep Stress Incr YES		WB 0.04	Horz(CT) 0.00	10	n/a	n/a		
BCDL 10.0	Code FBC2020/TPI2014		Matrix-S					Weight: 62 lb	FT = 20%

LUMBER-	BRACING-
TOP CHORD 2x4 SP No.2	TOP CHORD 2-0-0 oc purlins (6-0-0 max.).
BOT CHORD 2x4 SP No.2	BOT CHORD Rigid ceiling directly applied or 10-0-0 oc bracing.
OTHERS 2x4 SP No.3	

REACTIONS. All bearings 12-1-0.
 (lb) - Max Horz 2=53(LC 13)
 Max Uplift All uplift 100 lb or less at joint(s) 2, 10, 15, 16, 13, 12
 Max Grav All reactions 250 lb or less at joint(s) 2, 10, 14, 15, 16, 13, 12

FORCES. (lb) - Max. Comp./Max. Ten. - All forces 250 (lb) or less except when shown.

- NOTES-**
- Unbalanced roof live loads have been considered for this design.
 - Wind: ASCE 7-16; Vult=130mph (3-second gust) Vasd=101mph; TCDL=4.2psf; BCDL=3.0psf; h=18ft; Cat. II; Exp B; Encl., GCpi=0.18; MWFRS (envelope) gable end zone and C-C Corner(3E) -2-0-0 to 1-0-0, Exterior(2N) 1-0-0 to 6-0-8, Corner(3R) 6-0-8 to 9-0-8, Exterior(2N) 9-0-8 to 14-1-0 zone; C-C for members and forces & MWFRS for reactions shown; Lumber DOL=1.60 plate grip DOL=1.60
 - Truss designed for wind loads in the plane of the truss only. For studs exposed to wind (normal to the face), see Standard Industry Gable End Details as applicable, or consult qualified building designer as per ANSI/TPI 1.
 - Building Designer / Project engineer responsible for verifying applied roof live load shown covers rain loading requirements specific to the use of this truss component.
 - Gable requires continuous bottom chord bearing.
 - Gable studs spaced at 2-0-0 oc.
 - This truss has been designed for a 10.0 psf bottom chord live load nonconcurrent with any other live loads.
 - * This truss has been designed for a live load of 20.0psf on the bottom chord in all areas where a rectangle 3-6-0 tall by 2-0-0 wide will fit between the bottom chord and any other members.
 - Provide mechanical connection (by others) of truss to bearing plate capable of withstanding 100 lb uplift at joint(s) 2, 10, 15, 16, 13, 12.
 - Beveled plate or shim required to provide full bearing surface with truss chord at joint(s) 10.
 - Graphical purlin representation does not depict the size or the orientation of the purlin along the top and/or bottom chord.

This item has been electronically signed and sealed by O'Regan, Philip, PE using a Digital Signature. Printed copies of this document are not considered signed and sealed and the signature must be verified on any electronic copies.

Philip J. O'Regan PE No.58126
 MiTek Inc. DBA MiTek USA FL Cert 6634
 16023 Swingley Ridge Rd. Chesterfield, MO 63017
 Date:

August 4, 2023

<p>WARNING - Verify design parameters and READ NOTES ON THIS AND INCLUDED MITEK REFERENCE PAGE MII-7473 rev. 1/2/2023 BEFORE USE.</p> <p>Design valid for use only with MiTek® connectors. This design is based only upon parameters shown, and is for an individual building component, not a truss system. Before use, the building designer must verify the applicability of design parameters and properly incorporate this design into the overall building design. Bracing indicated is to prevent buckling of individual truss web and/or chord members only. Additional temporary and permanent bracing is always required for stability and to prevent collapse with possible personal injury and property damage. For general guidance regarding the fabrication, storage, delivery, erection and bracing of trusses and truss systems, see ANSI/TPI1 Quality Criteria and DSB-22 available from Truss Plate Institute (www.tpinst.org) and BCSI Building Component Safety Information available from the Structural Building Component Association (www.sbcsccomponents.com)</p>	 <p>16023 Swingley Ridge Rd. Chesterfield, MO 63017 314.434.1200 / MiTek-US.com</p>
--	--

Job 3626267	Truss T05	Truss Type COMMON	Qty 4	Ply 1	JT BLDRS - LOT 12 CCP	T31220139
----------------	--------------	----------------------	----------	----------	-----------------------	-----------

Builders FirstSource, Lake City, FL 32055

8.530 s May 26 2022 MiTek Industries, Inc. Fri Aug 4 10:50:43 2023 Page 1

ID:2eRY39KFhR2benj7cX?4RUzckGi-jk64NJs9nNOouK6Ma4pbAmzt3AO5FAITn?zq63yrPzg

Job Reference (optional)



Scale: 1/2"=1'

LOADING (psf)	SPACING-	CSL	DEFL.	in (loc)	I/defl	L/d	PLATES	GRIP
TCLL 20.0	Plate Grip DOL 1.25	TC 0.39	Vert(LL) -0.04	5-8	>999	240	MT20	244/190
TCDL 7.0	Lumber DOL 1.25	BC 0.36	Vert(CT) -0.08	5-8	>999	180		
BCLL 0.0 *	Rep Stress Incr YES	WB 0.10	Horz(CT) 0.00	4	n/a	n/a		
BCDL 10.0	Code FBC2020/TPI2014	Matrix-MS						
							Weight: 46 lb	FT = 20%

LUMBER-

TOP CHORD 2x4 SP No.2
 BOT CHORD 2x4 SP No.2
 WEBS 2x4 SP No.3

BRACING-

TOP CHORD Structural wood sheathing directly applied or 6-0-0 oc purlins.
 BOT CHORD Rigid ceiling directly applied or 10-0-0 oc bracing.

REACTIONS.

(size) 4=0-3-8, 2=0-3-8
 Max Horz 2=72(LC 16)
 Max Uplift 4=86(LC 13), 2=132(LC 12)
 Max Grav 4=438(LC 1), 2=564(LC 1)

FORCES. (lb) - Max. Comp./Max. Ten. - All forces 250 (lb) or less except when shown.

TOP CHORD 2-3=-599/229, 3-4=-595/240
 BOT CHORD 2-5=-137/472, 4-5=-137/472
 WEBS 3-5=-0/267

NOTES-

- 1) Unbalanced roof live loads have been considered for this design.
- 2) Wind: ASCE 7-16; Vult=130mph (3-second gust) Vasd=101mph; TCDL=4.2psf; BCDL=3.0psf; h=18ft; Cat. II; Exp B; Encl., GCpi=0.18; MWFRS (envelope) gable end zone and C-C Exterior(2E) -2-0-0 to 1-0-0, Interior(1) 1-0-0 to 6-0-8, Exterior(2R) 6-0-8 to 9-0-8, Interior(1) 9-0-8 to 12-1-0 zone; C-C for members and forces & MWFRS for reactions shown; Lumber DOL=1.60 plate grip DOL=1.60
- 3) Building Designer / Project engineer responsible for verifying applied roof live load shown covers rain loading requirements specific to the use of this truss component.
- 4) This truss has been designed for a 10.0 psf bottom chord live load nonconcurrent with any other live loads.
- 5) * This truss has been designed for a live load of 20.0psf on the bottom chord in all areas where a rectangle 3-6-0 tall by 2-0-0 wide will fit between the bottom chord and any other members.
- 6) Provide mechanical connection (by others) of truss to bearing plate capable of withstanding 100 lb uplift at joint(s) 4 except (jt=lb) 2=132.

This item has been electronically signed and sealed by O'Regan, Philip, PE using a Digital Signature. Printed copies of this document are not considered signed and sealed and the signature must be verified on any electronic copies.

Philip J. O'Regan PE No.58126
 MiTek Inc. DBA MiTek USA FL Cert 6634
 16023 Swingley Ridge Rd. Chesterfield, MO 63017
 Date:

August 4, 2023

WARNING - Verify design parameters and READ NOTES ON THIS AND INCLUDED MITEK REFERENCE PAGE MII-7473 rev. 1/2/2023 BEFORE USE.

Design valid for use only with MiTek® connectors. This design is based only upon parameters shown, and is for an individual building component, not a truss system. Before use, the building designer must verify the applicability of design parameters and properly incorporate this design into the overall building design. Bracing indicated is to prevent buckling of individual truss web and/or chord members only. Additional temporary and permanent bracing is always required for stability and to prevent collapse with possible personal injury and property damage. For general guidance regarding the fabrication, storage, delivery, erection and bracing of trusses and truss systems, see **ANSI/TPI1 Quality Criteria and DSB-22** available from Truss Plate Institute (www.tpinst.org) and **BCSI Building Component Safety Information** available from the Structural Building Component Association (www.sbcsccomponents.com)

MiTek®

16023 Swingley Ridge Rd.
 Chesterfield, MO 63017
 314.434.1200 / MiTek-US.com

Job 3626267	Truss T06	Truss Type HALF HIP GIRDER	Qty 1	Ply 1	JT BLDRS - LOT 12 CCP	T31220140
----------------	--------------	-------------------------------	----------	----------	-----------------------	-----------

Builders FirstSource, Lake City, FL 32055

ID:2eRY39KFhR2benj7cX?4RUzckGi-f6Eqn?IQJ?eW8eGkhUr4FB35T_x8junlEJSxAyyrPze

8.530 s May 26 2022 MiTek Industries, Inc. Fri Aug 4 10:50:45 2023 Page 1

Job Reference (optional)

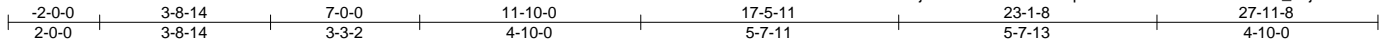

Scale = 1:50.4

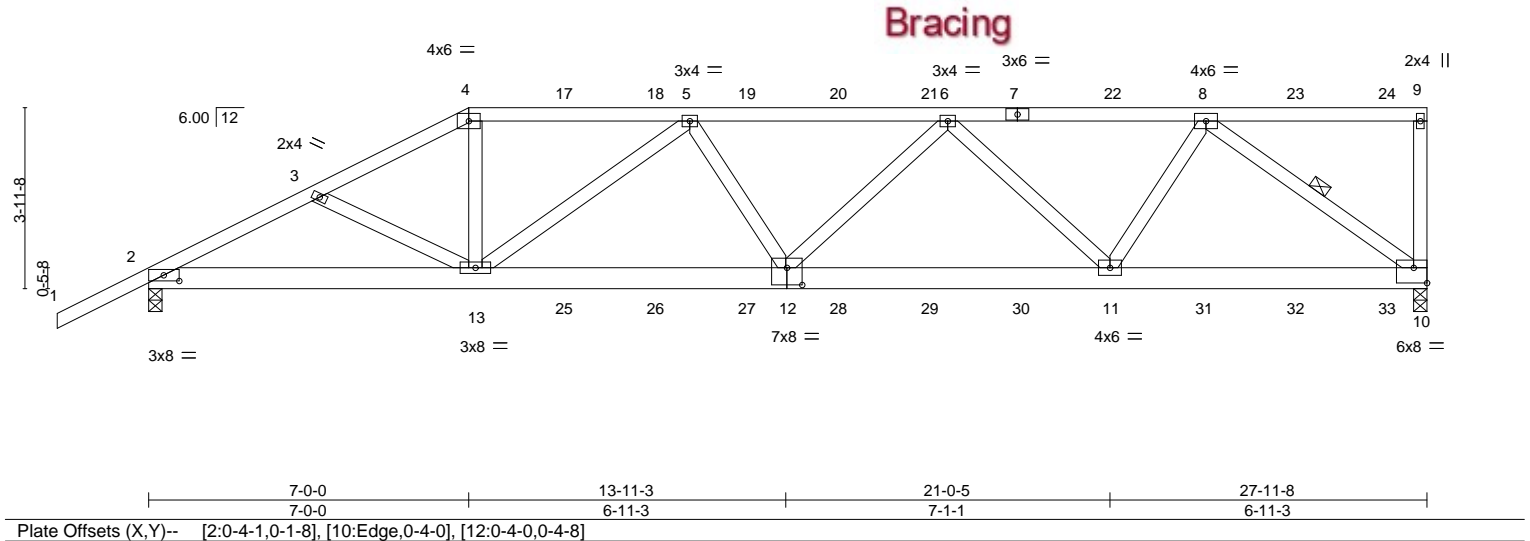

LOADING (psf)	SPACING-	CSI.	DEFL.	PLATES	GRIP
TCLL 20.0	2-0-0	TC 0.85	in (loc) l/defl L/d	MT20	244/190
TCDL 7.0	Plate Grip DOL 1.25	BC 0.90	Vert(LL) -0.19 12-13 >999 240		
BCLL 0.0 *	Lumber DOL 1.25	WB 0.81	Vert(CT) -0.37 12-13 >896 180		
BCDL 10.0	Rep Stress Incr NO	Matrix-MS	Horz(CT) 0.10 10 n/a n/a		
	Code FBC2020/TP12014			Weight: 169 lb	FT = 20%

LUMBER-

TOP CHORD 2x4 SP No.2
 BOT CHORD 2x6 SP No.2
 WEBS 2x4 SP No.3

BRACING-

TOP CHORD Structural wood sheathing directly applied or 2-1-1 oc purlins, except end verticals.
 BOT CHORD Rigid ceiling directly applied or 7-1-8 oc bracing.
 WEBS 1 Row at midpt 8-10

REACTIONS.

(size) 10=0-3-8, 2=0-3-8
 Max Horz 2=146(LC 8)
 Max Uplift 10=-562(LC 5), 2=-507(LC 8)
 Max Grav 10=2218(LC 1), 2=2015(LC 1)

FORCES. (lb) - Max. Comp./Max. Ten. - All forces 250 (lb) or less except when shown.

TOP CHORD 2-3=-3770/929, 3-4=-3623/886, 4-5=-3266/826, 5-6=-4249/1028, 6-8=-3145/750
 BOT CHORD 2-13=902/3319, 12-13=-1082/4184, 11-12=-1041/4003, 10-11=-642/2424
 WEBS 4-13=-208/1223, 5-13=-1202/384, 5-12=0/300, 6-12=-20/453, 6-11=-1219/424, 8-11=-223/1426, 8-10=-3004/798

NOTES-

- Unbalanced roof live loads have been considered for this design.
- Wind: ASCE 7-16; Vult=130mph (3-second gust) Vasd=101mph; TC DL=4.2psf; BCDL=3.0psf; h=18ft; Cat. II; Exp B; Encl., GCp=0.18; MWFRS (envelope) gable end zone; Lumber DOL=1.60 plate grip DOL=1.60
- Building Designer / Project engineer responsible for verifying applied roof live load shown covers rain loading requirements specific to the use of this truss component.
- Provide adequate drainage to prevent water ponding.
- This truss has been designed for a 10.0 psf bottom chord live load nonconcurrent with any other live loads.
- * This truss has been designed for a live load of 20.0psf on the bottom chord in all areas where a rectangle 3-6-0 tall by 2-0-0 wide will fit between the bottom chord and any other members.
- Provide mechanical connection (by others) of truss to bearing plate capable of withstanding 100 lb uplift at joint(s) except (jt=lb) 10=562, 2=507.
- Hanger(s) or other connection device(s) shall be provided sufficient to support concentrated load(s) 126 lb down and 87 lb up at 7-0-0, 107 lb down and 87 lb up at 9-0-12, 107 lb down and 87 lb up at 11-0-12, 107 lb down and 87 lb up at 13-0-12, 107 lb down and 87 lb up at 15-0-12, 107 lb down and 83 lb up at 17-0-12, 107 lb down and 87 lb up at 19-0-12, 107 lb down and 87 lb up at 21-0-12, 107 lb down and 87 lb up at 23-0-12, and 107 lb down and 87 lb up at 25-0-12, and 114 lb down and 87 lb up at 27-0-12 on top chord, and 294 lb down and 73 lb up at 7-0-0, 85 lb down at 9-0-12, 85 lb down at 11-0-12, 85 lb down at 13-0-12, 85 lb down at 15-0-12, 85 lb down at 17-0-12, 85 lb down at 19-0-12, 85 lb down at 21-0-12, 85 lb down at 23-0-12, and 85 lb down at 25-0-12, and 90 lb down at 27-0-12 on bottom chord. The design/selection of such connection device(s) is the responsibility of others.
- In the LOAD CASE(S) section, loads applied to the face of the truss are noted as front (F) or back (B).

LOAD CASE(S) Standard

This item has been electronically signed and sealed by O'Regan, Philip, PE using a Digital Signature. Printed copies of this document are not considered signed and sealed and the signature must be verified on any electronic copies.

Philip J. O'Regan PE No.58126
 MiTek Inc. DBA MiTek USA FL Cert 6634
 16023 Swingley Ridge Rd. Chesterfield, MO 63017
 Date:

August 4, 2023

Continued on page 2

WARNING - Verify design parameters and READ NOTES ON THIS AND INCLUDED MITEK REFERENCE PAGE MII-7473 rev. 1/2/2023 BEFORE USE.

Design valid for use only with MiTek® connectors. This design is based only upon parameters shown, and is for an individual building component, not a truss system. Before use, the building designer must verify the applicability of design parameters and properly incorporate this design into the overall building design. Bracing indicated is to prevent buckling of individual truss web and/or chord members only. Additional temporary and permanent bracing is always required for stability and to prevent collapse with possible personal injury and property damage. For general guidance regarding the fabrication, storage, delivery, erection and bracing of trusses and truss systems, see **ANSI/TP1 Quality Criteria and DSB-22** available from Truss Plate Institute (www.tpinst.org) and **BCSI Building Component Safety Information** available from the Structural Building Component Association (www.sbcsccomponents.com)

MiTek®

16023 Swingley Ridge Rd.
 Chesterfield, MO 63017
 314.434.1200 / MiTek-US.com

Job 3626267	Truss T06	Truss Type HALF HIP GIRDER	Qty 1	Ply 1	JT BLDRS - LOT 12 CCP Job Reference (optional)	T31220140
----------------	--------------	-------------------------------	----------	----------	---	-----------

Builders FirstSource, Lake City, FL 32055

8.530 s May 26 2022 MiTek Industries, Inc. Fri Aug 4 10:50:45 2023 Page 2
ID:2eRY39KFhR2benj7cX?4RUzckGi-f6Eqn?IQJ?eW8eGkhUr4FB35T_x8junIEJSxAyyrPze

LOAD CASE(S) Standard

1) Dead + Roof Live (balanced): Lumber Increase=1.25, Plate Increase=1.25

Uniform Loads (plf)

Vert: 1-4=-54, 4-9=-54, 10-14=-20

Concentrated Loads (lb)

Vert: 4=-107(F) 7=-107(F) 13=-280(F) 11=-60(F) 8=-107(F) 17=-107(F) 18=-107(F) 19=-107(F) 20=-107(F) 21=-107(F) 22=-107(F) 23=-107(F) 24=-114(F)
25=-60(F) 26=-60(F) 27=-60(F) 28=-60(F) 29=-60(F) 30=-60(F) 31=-60(F) 32=-60(F) 33=-62(F)

WARNING - Verify design parameters and READ NOTES ON THIS AND INCLUDED MITEK REFERENCE PAGE MII-7473 rev. 1/2/2023 BEFORE USE.

Design valid for use only with MiTek® connectors. This design is based only upon parameters shown, and is for an individual building component, not a truss system. Before use, the building designer must verify the applicability of design parameters and properly incorporate this design into the overall building design. Bracing indicated is to prevent buckling of individual truss web and/or chord members only. Additional temporary and permanent bracing is always required for stability and to prevent collapse with possible personal injury and property damage. For general guidance regarding the fabrication, storage, delivery, erection and bracing of trusses and truss systems, see **ANSI/TPI1 Quality Criteria and DSB-22** available from Truss Plate Institute (www.tpinst.org) and **BCSI Building Component Safety Information** available from the Structural Building Component Association (www.sbcsccomponents.com)

MiTek®

16023 Swingley Ridge Rd.
Chesterfield, MO 63017
314.434.1200 / MiTek-US.com

Job 3626267	Truss T07	Truss Type HALF HIP	Qty 1	Ply 1	JT BLDRS - LOT 12 CCP	T31220141
----------------	--------------	------------------------	----------	----------	-----------------------	-----------

Builders FirstSource, Lake City, FL 32055

8.530 s May 26 2022 MiTek Industries, Inc. Fri Aug 4 10:50:45 2023 Page 1

ID:2eRY39KFhR2benj7cX?4RUzckGi-f6Eqn?tQJ?eW8eGkhUr4FB3Bl_yPjFIEJSxAyyrPze

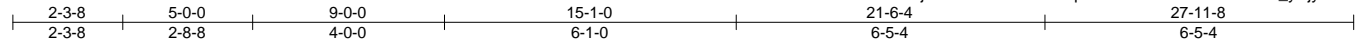

Scale: 1/4"=1'

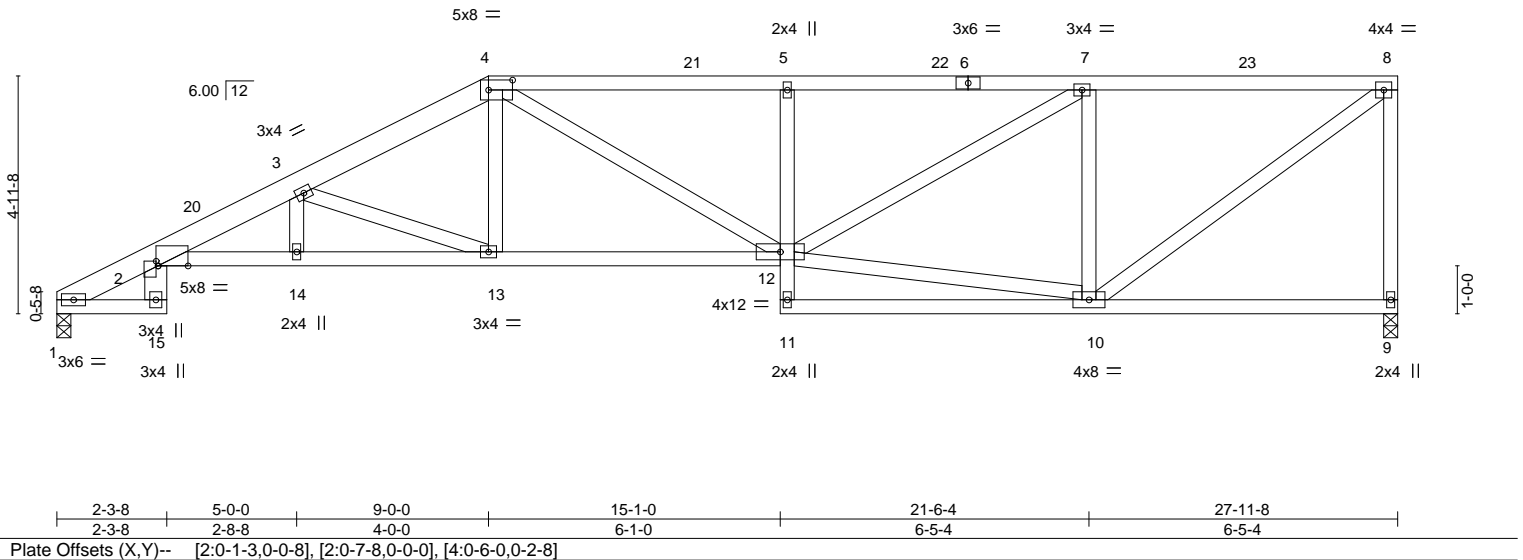

LOADING (psf)	SPACING-	2-0-0	CSI.	DEFL.	in (loc)	l/defl	L/d	PLATES	GRIP
TCLL 20.0	Plate Grip DOL	1.25	TC 0.51	Vert(LL)	-0.18 14	>999	240	MT20	244/190
TCDL 7.0	Lumber DOL	1.25	BC 0.89	Vert(CT)	-0.35 12-13	>942	180		
BCLL 0.0 *	Rep Stress Incr	YES	WB 0.52	Horz(CT)	0.21 9	n/a	n/a		
BCDL 10.0	Code	FBC2020/TPI2014	Matrix-MS					Weight: 168 lb	FT = 20%

LUMBER-	BRACING-
TOP CHORD 2x4 SP No.2 *Except* 1-4: 2x6 SP M 26	TOP CHORD Structural wood sheathing directly applied or 3-9-0 oc purlins, except end verticals.
BOT CHORD 2x4 SP No.2 *Except* 2-15: 2x6 SP No.2, 2-12: 2x4 SP No.1, 5-11: 2x4 SP No.3	BOT CHORD Rigid ceiling directly applied or 6-11-2 oc bracing.
WEBS 2x4 SP No.3	

REACTIONS. (size) 1=0-3-8, 9=0-3-8
 Max Horz 1=152(LC 12)
 Max Uplift 1=-225(LC 12), 9=-252(LC 9)
 Max Grav 1=1030(LC 1), 9=1024(LC 1)

FORCES. (lb) - Max. Comp./Max. Ten. - All forces 250 (lb) or less except when shown.
 TOP CHORD 2-19=-567/27, 2-3=-2859/707, 3-4=-1980/473, 4-5=-1969/476, 5-7=-1940/469,
 7-8=-1106/268, 8-9=-969/266
 BOT CHORD 2-14=-783/2713, 13-14=-783/2713, 12-13=-448/1726, 5-12=-348/162
 WEBS 4-13=-91/511, 4-12=-145/395, 10-12=-251/1025, 7-12=-288/940, 7-10=-843/284,
 8-10=-329/1362, 3-13=-1076/361

- NOTES-**
- Unbalanced roof live loads have been considered for this design.
 - Wind: ASCE 7-16; Vult=130mph (3-second gust) Vasd=101mph; TC DL=4.2psf; BCDL=3.0psf; h=18ft; Cat. II; Exp B; Encl., GCp=0.18; MWFRS (envelope) gable end zone and C-C Exterior(2E) 0-1-12 to 3-1-12, Interior(1) 3-1-12 to 9-0-0, Exterior(2R) 9-0-0 to 13-2-15, Interior(1) 13-2-15 to 27-9-12 zone; C-C for members and forces & MWFRS for reactions shown; Lumber DOL=1.60 plate grip DOL=1.60
 - Building Designer / Project engineer responsible for verifying applied roof live load shown covers rain loading requirements specific to the use of this truss component.
 - Provide adequate drainage to prevent water ponding.
 - This truss has been designed for a 10.0 psf bottom chord live load nonconcurrent with any other live loads.
 - * This truss has been designed for a live load of 20.0psf on the bottom chord in all areas where a rectangle 3-6-0 tall by 2-0-0 wide will fit between the bottom chord and any other members.
 - Provide mechanical connection (by others) of truss to bearing plate capable of withstanding 100 lb uplift at joint(s) except (jt=lb) 1=225, 9=252.

This item has been electronically signed and sealed by O'Regan, Philip, PE using a Digital Signature. Printed copies of this document are not considered signed and sealed and the signature must be verified on any electronic copies.

Philip J. O'Regan PE No.58126
 MiTek Inc. DBA MiTek USA FL Cert 6634
 16023 Swingley Ridge Rd. Chesterfield, MO 63017
 Date:

August 4, 2023

WARNING - Verify design parameters and READ NOTES ON THIS AND INCLUDED MITEK REFERENCE PAGE MII-7473 rev. 1/2/2023 BEFORE USE.

Design valid for use only with MiTek® connectors. This design is based only upon parameters shown, and is for an individual building component, not a truss system. Before use, the building designer must verify the applicability of design parameters and properly incorporate this design into the overall building design. Bracing indicated is to prevent buckling of individual truss web and/or chord members only. Additional temporary and permanent bracing is always required for stability and to prevent collapse with possible personal injury and property damage. For general guidance regarding the fabrication, storage, delivery, erection and bracing of trusses and truss systems, see **ANSI/TPI1 Quality Criteria and DSB-22** available from Truss Plate Institute (www.tpinst.org) and **BCSI Building Component Safety Information** available from the Structural Building Component Association (www.sbcsccomponents.com)

MiTek®

16023 Swingley Ridge Rd.
 Chesterfield, MO 63017
 314.434.1200 / MiTek-US.com

Job 3626267	Truss T08	Truss Type HALF HIP	Qty 1	Ply 1	JT BLDRS - LOT 12 CCP	T31220142
----------------	--------------	------------------------	----------	----------	-----------------------	-----------

Builders FirstSource, Lake City, FL 32055

8.530 s May 26 2022 MiTek Industries, Inc. Fri Aug 4 10:50:46 2023 Page 1
ID:2eRY39KFhR2benj7cX?4RUzckGi-7JoC?Lu24ImNloqxFCMJoObMVOHoSOhvTzCUIQyrPzd

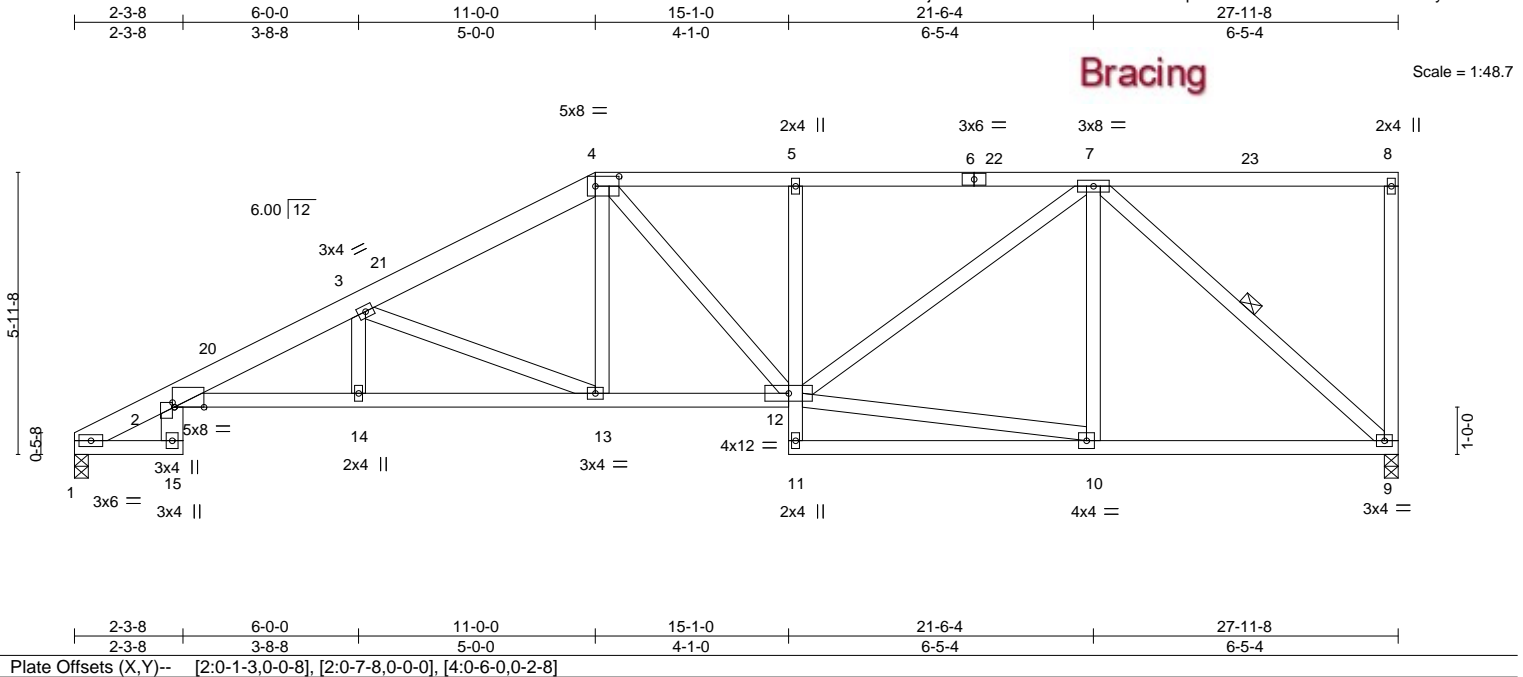

LOADING (psf)	SPACING-	2-0-0	CSI.	DEFL.	in (loc)	l/defl	L/d	PLATES	GRIP
TCLL 20.0	Plate Grip DOL	1.25	TC 0.51	Vert(LL)	-0.19	2-14	>999	MT20	244/190
TCDL 7.0	Lumber DOL	1.25	BC 0.88	Vert(CT)	-0.36	2-14	>932		
BCLL 0.0 *	Rep Stress Incr	YES	WB 0.64	Horz(CT)	0.23	9	n/a		
BCDL 10.0	Code	FBC2020/TP12014	Matrix-MS					Weight: 179 lb	FT = 20%

LUMBER-	BRACING-
TOP CHORD 2x4 SP No.2 *Except* 1-4: 2x6 SP M 26	TOP CHORD Structural wood sheathing directly applied or 4-5-2 oc purlins, except end verticals.
BOT CHORD 2x4 SP No.2 *Except* 2-15: 2x6 SP No.2, 2-12: 2x4 SP No.1, 5-11: 2x4 SP No.3	BOT CHORD Rigid ceiling directly applied or 10-0-0 oc bracing. Except: 7-0-8 oc bracing: 2-14 7-3-15 oc bracing: 13-14.
WEBS 2x4 SP No.3	WEBS 1 Row at midpt 7-9
REACTIONS. (size) 1=0-3-8, 9=0-3-8 Max Horz 1=185(LC 12) Max Uplift 1=-223(LC 12), 9=-247(LC 9) Max Grav 1=1030(LC 1), 9=1024(LC 1)	

FORCES. (lb) - Max. Comp./Max. Ten. - All forces 250 (lb) or less except when shown.
TOP CHORD 2-19=-567/0, 2-3=-2621/647, 3-4=-1717/416, 4-5=-1528/390, 5-7=-1523/390
BOT CHORD 2-14=-747/2459, 13-14=-747/2459, 12-13=-398/1464, 5-12=-293/137, 9-10=-221/930
WEBS 3-14=-2/261, 3-13=-1088/379, 4-13=-109/502, 10-12=-214/854, 7-12=-251/738,
7-9=-1233/292

- NOTES-**
- Unbalanced roof live loads have been considered for this design.
 - Wind: ASCE 7-16; Vult=130mph (3-second gust) Vasd=101mph; TC DL=4.2psf; BCDL=3.0psf; h=18ft; Cat. II; Exp B; Encl., GCpi=0.18; MWFRS (envelope) gable end zone and C-C Exterior(2E) 0-1-12 to 3-1-12, Interior(1) 3-1-12 to 11-0-0, Exterior(2R) 11-0-0 to 15-2-12, Interior(1) 15-2-12 to 27-9-12 zone; C-C for members and forces & MWFRS for reactions shown; Lumber DOL=1.60 plate grip DOL=1.60
 - Building Designer / Project engineer responsible for verifying applied roof live load shown covers rain loading requirements specific to the use of this truss component.
 - Provide adequate drainage to prevent water ponding.
 - This truss has been designed for a 10.0 psf bottom chord live load nonconcurrent with any other live loads.
 - * This truss has been designed for a live load of 20.0psf on the bottom chord in all areas where a rectangle 3-6-0 tall by 2-0-0 wide will fit between the bottom chord and any other members.
 - Provide mechanical connection (by others) of truss to bearing plate capable of withstanding 100 lb uplift at joint(s) except (jt=lb) 1=223, 9=247.

This item has been electronically signed and sealed by O'Regan, Philip, PE using a Digital Signature. Printed copies of this document are not considered signed and sealed and the signature must be verified on any electronic copies.

Philip J. O'Regan PE No.58126
MiTek Inc. DBA MiTek USA FL Cert 6634
16023 Swingley Ridge Rd. Chesterfield, MO 63017
Date:

August 4, 2023

WARNING - Verify design parameters and READ NOTES ON THIS AND INCLUDED MITEK REFERENCE PAGE MII-7473 rev. 1/2/2023 BEFORE USE.

Design valid for use only with MiTek® connectors. This design is based only upon parameters shown, and is for an individual building component, not a truss system. Before use, the building designer must verify the applicability of design parameters and properly incorporate this design into the overall building design. Bracing indicated is to prevent buckling of individual truss web and/or chord members only. Additional temporary and permanent bracing is always required for stability and to prevent collapse with possible personal injury and property damage. For general guidance regarding the fabrication, storage, delivery, erection and bracing of trusses and truss systems, see **ANSI/TP11 Quality Criteria and DSB-22** available from Truss Plate Institute (www.tpinst.org) and **BCSI Building Component Safety Information** available from the Structural Building Component Association (www.sbcsccomponents.com)

MiTek®

16023 Swingley Ridge Rd.
Chesterfield, MO 63017
314.434.1200 / MiTek-US.com

Job 3626267	Truss T09	Truss Type HALF HIP	Qty 1	Ply 1	JT BLDRS - LOT 12 CCP	T31220143
----------------	--------------	------------------------	----------	----------	-----------------------	-----------

Builders FirstSource, Lake City, FL 32055

8.530 s May 26 2022 MiTek Industries, Inc. Fri Aug 4 10:50:47 2023 Page 1
ID:2eRY39KFhR2benj7cX?4RUzckGi-cVMbChvgrcuENxP7ptYKc8WbndzBIX2idx1FqyrPzc

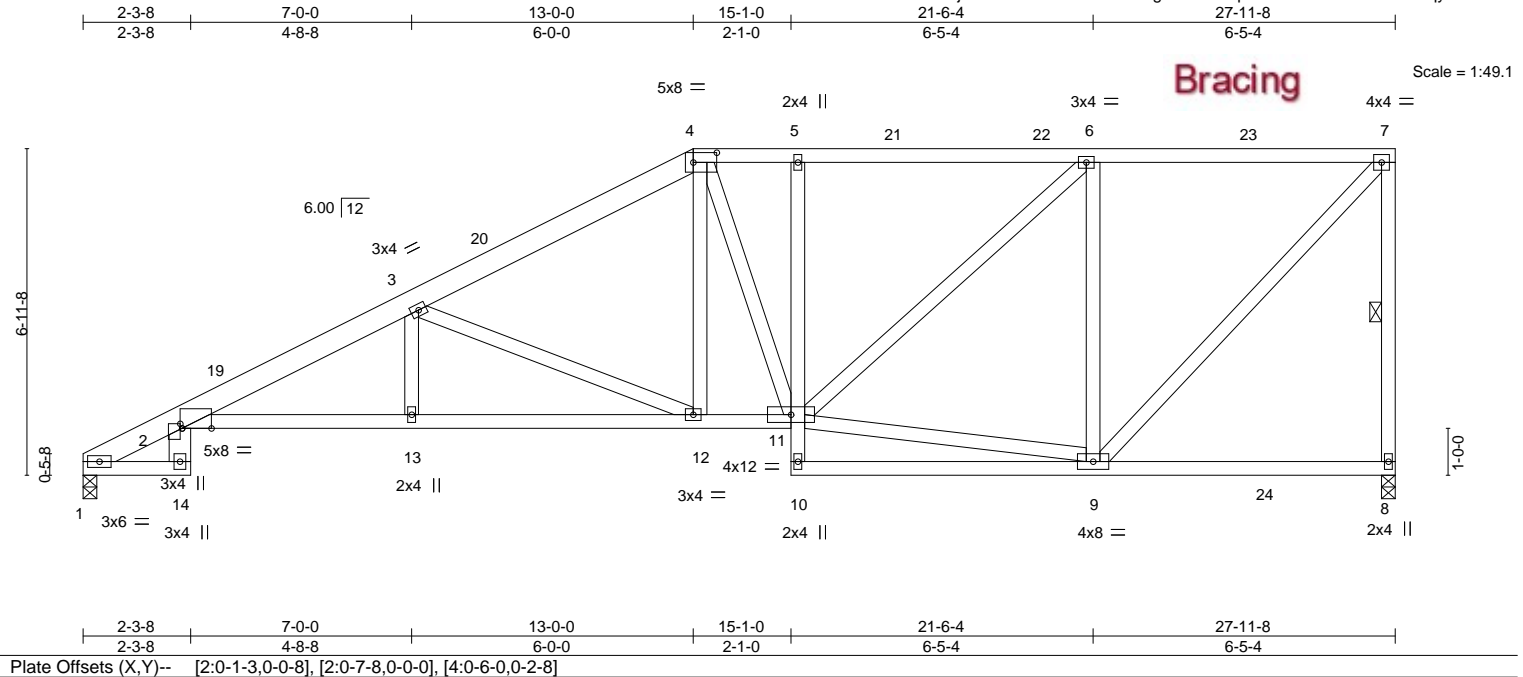

LOADING (psf)	SPACING-	2-0-0	CSI.	DEFL.	in (loc)	I/defl	L/d	PLATES	GRIP
TCLL 20.0	Plate Grip DOL	1.25	TC 0.55	Vert(LL)	-0.25 2-13	>999	240	MT20	244/190
TCDL 7.0	Lumber DOL	1.25	BC 0.88	Vert(CT)	-0.45 2-13	>744	180		
BCLL 0.0 *	Rep Stress Incr	YES	WB 0.98	Horz(CT)	0.25 8	n/a	n/a		
BCDL 10.0	Code	FBC2020/TP12014	Matrix-MS					Weight: 191 lb	FT = 20%

LUMBER-
TOP CHORD 2x6 SP M 26 *Except*
4-7: 2x4 SP No.2
BOT CHORD 2x4 SP No.2 *Except*
2-14: 2x6 SP No.2, 2-11: 2x4 SP No.1, 5-10: 2x4 SP No.3
WEBS 2x4 SP No.3

BRACING-
TOP CHORD Structural wood sheathing directly applied or 4-9-10 oc purlins, except end verticals.
BOT CHORD Rigid ceiling directly applied or 10-0-0 oc bracing. Except:
7-1-9 oc bracing: 2-13
7-5-6 oc bracing: 12-13.
WEBS 1 Row at midpt 7-8

REACTIONS. (size) 1=0-3-8, 8=0-3-8
Max Horz 1=218(LC 12)
Max Uplift 1=-220(LC 12), 8=-240(LC 9)
Max Grav 1=1106(LC 2), 8=1131(LC 2)

FORCES. (lb) - Max. Comp./Max. Ten. - All forces 250 (lb) or less except when shown.
TOP CHORD 2-18=-603/0, 2-3=-2588/595, 3-4=-1588/360, 4-5=-1336/348, 5-6=-1335/350,
6-7=-842/178, 7-8=-1009/254
BOT CHORD 2-13=-719/2416, 12-13=-719/2416, 11-12=-354/1348, 5-11=-265/126
WEBS 3-13=0/301, 3-12=-1175/398, 4-12=-117/635, 9-11=-181/741, 6-11=-230/649,
6-9=-797/263, 7-9=-258/1217

- NOTES-**
- Unbalanced roof live loads have been considered for this design.
 - Wind: ASCE 7-16; Vult=130mph (3-second gust) Vasd=101mph; TC DL=4.2psf; BCDL=3.0psf; h=18ft; Cat. II; Exp B; Encl., GCp=0.18; MWFRS (envelope) gable end zone and C-C Exterior(2E) 0-1-12 to 3-1-12, Interior(1) 3-1-12 to 13-0-0, Exterior(2R) 13-0-0 to 17-2-15, Interior(1) 17-2-15 to 27-9-12 zone; C-C for members and forces & MWFRS for reactions shown; Lumber DOL=1.60 plate grip DOL=1.60
 - Building Designer / Project engineer responsible for verifying applied roof live load shown covers rain loading requirements specific to the use of this truss component.
 - Provide adequate drainage to prevent water ponding.
 - This truss has been designed for a 10.0 psf bottom chord live load nonconcurrent with any other live loads.
 - * This truss has been designed for a live load of 20.0psf on the bottom chord in all areas where a rectangle 3-6-0 tall by 2-0-0 wide will fit between the bottom chord and any other members, with BCDL = 10.0psf.
 - Provide mechanical connection (by others) of truss to bearing plate capable of withstanding 100 lb uplift at joint(s) except (jt=lb) 1=220, 8=240.

This item has been electronically signed and sealed by O'Regan, Philip, PE using a Digital Signature. Printed copies of this document are not considered signed and sealed and the signature must be verified on any electronic copies.

Philip J. O'Regan PE No.58126
MiTek Inc. DBA MiTek USA FL Cert 6634
16023 Swingley Ridge Rd. Chesterfield, MO 63017
Date:

August 4, 2023

WARNING - Verify design parameters and READ NOTES ON THIS AND INCLUDED MITEK REFERENCE PAGE MII-7473 rev. 1/2/2023 BEFORE USE.

Design valid for use only with MiTek® connectors. This design is based only upon parameters shown, and is for an individual building component, not a truss system. Before use, the building designer must verify the applicability of design parameters and properly incorporate this design into the overall building design. Bracing indicated is to prevent buckling of individual truss web and/or chord members only. Additional temporary and permanent bracing is always required for stability and to prevent collapse with possible personal injury and property damage. For general guidance regarding the fabrication, storage, delivery, erection and bracing of trusses and truss systems, see **ANSI/TP1 Quality Criteria and DSB-22** available from Truss Plate Institute (www.tpinst.org) and **BCSI Building Component Safety Information** available from the Structural Building Component Association (www.sbcsccomponents.com)

MiTek®

16023 Swingley Ridge Rd.
Chesterfield, MO 63017
314.434.1200 / MiTek-US.com

Job 3626267	Truss T10	Truss Type HIP	Qty 1	Ply 1	JT BLDRS - LOT 12 CCP	T31220144
----------------	--------------	-------------------	----------	----------	-----------------------	-----------

Builders FirstSource, Lake City, FL 32055

8.530 s May 26 2022 MiTek Industries, Inc. Fri Aug 4 10:50:47 2023 Page 1
ID:2eRY39KFhR2benj7cX?4RUzckGi-cVMbChvgrcuENxP7pvtYKc8WHndxBta2idx1FqyrPzc

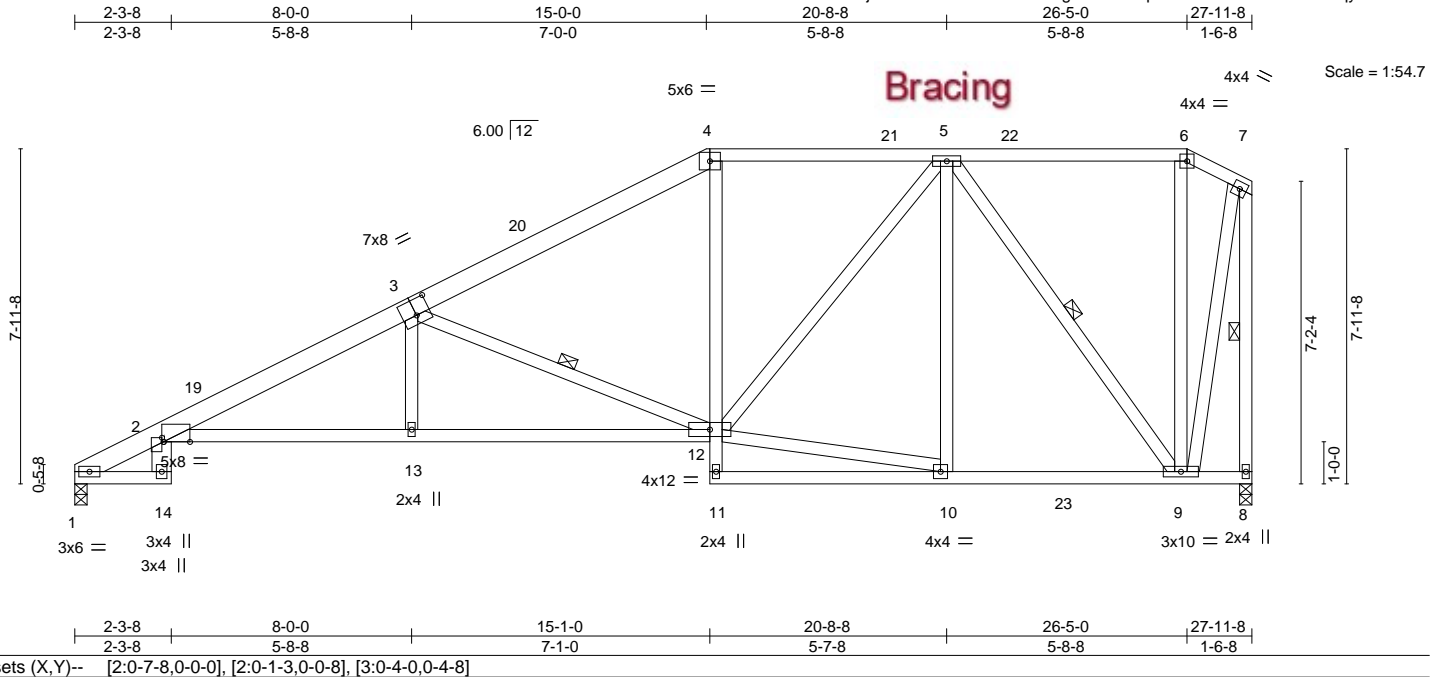

Plate Offsets (X,Y)-- [2:0-7-8,0-0-0], [2:0-1-3,0-0-8], [3:0-4-0,0-4-8]

LOADING (psf)	SPACING-	2-0-0	CSI.	DEFL.	in (loc)	l/defl	L/d	PLATES	GRIP
TCLL 20.0	Plate Grip DOL	1.25	TC 0.57	Vert(LL)	-0.30	2-13	>999	MT20	244/190
TCDL 7.0	Lumber DOL	1.25	BC 0.88	Vert(CT)	-0.53	2-13	>625		
BCLL 0.0 *	Rep Stress Incr	YES	WB 0.47	Horz(CT)	0.27	8	n/a		
BCDL 10.0	Code	FBC2020/TPI2014	Matrix-MS					Weight: 205 lb	FT = 20%

LUMBER-

TOP CHORD 2x4 SP No.2 *Except*
3-4: 2x6 SP No.2, 1-3: 2x6 SP M 26
BOT CHORD 2x4 SP No.2 *Except*
2-14: 2x6 SP No.2, 2-12: 2x4 SP No.1, 4-11: 2x4 SP No.3
WEBS 2x4 SP No.3

BRACING-

TOP CHORD Structural wood sheathing directly applied or 4-9-13 oc purlins, except end verticals.
BOT CHORD Rigid ceiling directly applied or 6-0-0 oc bracing.
WEBS 1 Row at midpt 3-12, 5-9, 7-8

REACTIONS.

(size) 1=0-3-8, 8=0-3-8
Max Horz 1=238(LC 12)
Max Uplift 1=187(LC 12), 8=198(LC 9)
Max Grav 1=1112(LC 2), 8=1126(LC 2)

FORCES. (lb) - Max. Comp./Max. Ten. - All forces 250 (lb) or less except when shown.

TOP CHORD 2-18=607/0, 2-3=2429/456, 3-4=1388/257, 4-5=1159/263, 6-7=257/56,
7-8=1125/216
BOT CHORD 2-13=596/2245, 12-13=596/2243, 4-12=6/366, 9-10=158/811
WEBS 3-13=0/353, 3-12=1181/391, 10-12=145/803, 5-12=167/549, 5-9=999/199,
7-9=193/1025

NOTES-

- Unbalanced roof live loads have been considered for this design.
- Wind: ASCE 7-16; Vult=130mph (3-second gust) Vasd=101mph; TCDL=4.2psf; BCDL=3.0psf; h=18ft; Cat. II; Exp B; Encl., GCp=0.18; MWFRS (envelope) gable end zone and C-C Exterior(2E) 0-1-12 to 3-1-12, Interior(1) 3-1-12 to 15-1-0, Exterior(2R) 15-1-0 to 19-3-15, Interior(1) 19-3-15 to 26-5-0, Exterior(2E) 26-5-0 to 27-9-12 zone; C-C for members and forces & MWFRS for reactions shown; Lumber DOL=1.60 plate grip DOL=1.60
- Building Designer / Project engineer responsible for verifying applied roof live load shown covers rain loading requirements specific to the use of this truss component.
- Provide adequate drainage to prevent water ponding.
- This truss has been designed for a 10.0 psf bottom chord live load nonconcurrent with any other live loads.
- * This truss has been designed for a live load of 20.0psf on the bottom chord in all areas where a rectangle 3-6-0 tall by 2-0-0 wide will fit between the bottom chord and any other members, with BCDL = 10.0psf.
- Provide mechanical connection (by others) of truss to bearing plate capable of withstanding 100 lb uplift at joint(s) except (jt=lb) 1=187, 8=198.

This item has been electronically signed and sealed by O'Regan, Philip, PE using a Digital Signature. Printed copies of this document are not considered signed and sealed and the signature must be verified on any electronic copies.

Philip J. O'Regan PE No.58126
MiTek Inc. DBA MiTek USA FL Cert 6634
16023 Swingley Ridge Rd. Chesterfield, MO 63017
Date:

August 4, 2023

WARNING - Verify design parameters and READ NOTES ON THIS AND INCLUDED MITEK REFERENCE PAGE MII-7473 rev. 1/2/2023 BEFORE USE.

Design valid for use only with MiTek® connectors. This design is based only upon parameters shown, and is for an individual building component, not a truss system. Before use, the building designer must verify the applicability of design parameters and properly incorporate this design into the overall building design. Bracing indicated is to prevent buckling of individual truss web and/or chord members only. Additional temporary and permanent bracing is always required for stability and to prevent collapse with possible personal injury and property damage. For general guidance regarding the fabrication, storage, delivery, erection and bracing of trusses and truss systems, see **ANSI/TPI1 Quality Criteria and DSB-22** available from Truss Plate Institute (www.tpinst.org) and **BCSI Building Component Safety Information** available from the Structural Building Component Association (www.sbcsccomponents.com)

MiTek®

16023 Swingley Ridge Rd.
Chesterfield, MO 63017
314.434.1200 / MiTek-US.com

Job 3626267	Truss T11	Truss Type HIP	Qty 1	Ply 1	JT BLDRS - LOT 12 CCP	T31220145
----------------	--------------	-------------------	----------	----------	-----------------------	-----------

Builders FirstSource, Lake City, FL 32055

ID:2eRY39KFhR2benj7cX?4RUzckGi-4hwzQ1wlcw05?5_JMdOnphgEBzlwKeCwHbnGyrPzb
8.530 s May 26 2022 MiTek Industries, Inc. Fri Aug 4 10:50:48 2023 Page 1

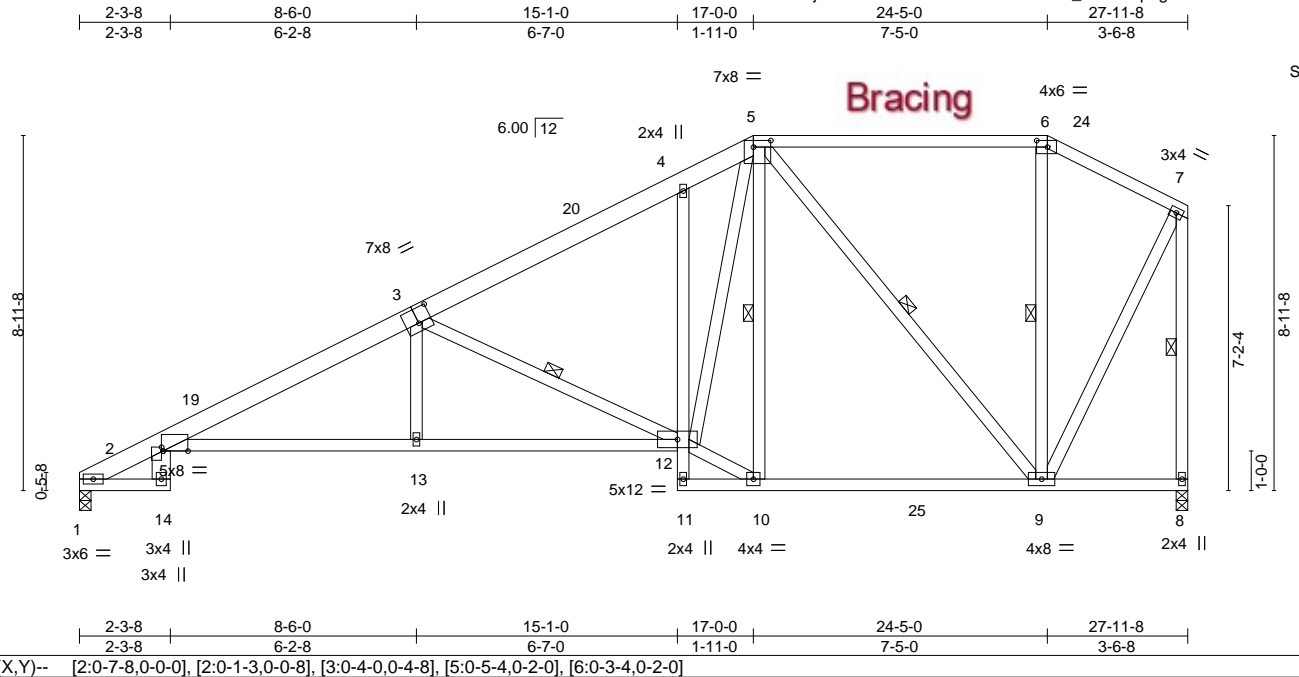

Plate Offsets (X,Y)-- [2:0-7-8,0-0-0], [2:0-1-3,0-0-8], [3:0-4-0,0-4-8], [5:0-5-4,0-2-0], [6:0-3-4,0-2-0]

LOADING (psf)	SPACING-	CSI.	DEFL.	PLATES	GRIP
TCLL 20.0	2-0-0	TC 0.62	in (loc) l/defl L/d	MT20	244/190
TCDL 7.0	Plate Grip DOL 1.25	BC 0.87	Vert(LL) -0.34 2-13 >992 240		
BCLL 0.0 *	Lumber DOL 1.25	WB 0.48	Vert(CT) -0.59 2-13 >564 180		
BCDL 10.0	Rep Stress Incr YES	Matrix-MS	Horz(CT) 0.29 8 n/a n/a		
	Code FBC2020/TPI2014			Weight: 207 lb	FT = 20%

LUMBER-

TOP CHORD 2x4 SP No.2 *Except*
3-5: 2x6 SP No.2, 1-3: 2x6 SP M 26
BOT CHORD 2x4 SP No.2 *Except*
2-14: 2x6 SP No.2, 2-12: 2x4 SP No.1, 4-11: 2x4 SP No.3
WEBS 2x4 SP No.3

BRACING-

TOP CHORD Structural wood sheathing directly applied or 4-8-15 oc purlins, except end verticals.
BOT CHORD Rigid ceiling directly applied or 6-0-0 oc bracing.
WEBS 1 Row at midpt 3-12, 5-10, 5-9, 6-9, 7-8

REACTIONS.

(size) 1=0-3-8, 8=0-3-8
Max Horz 1=253(LC 12)
Max Uplift 1=-212(LC 12), 8=-210(LC 12)
Max Grav 1=1122(LC 2), 8=1134(LC 2)

FORCES. (lb) - Max. Comp./Max. Ten. - All forces 250 (lb) or less except when shown.

TOP CHORD 2-18=-613/0, 2-3=-2385/510, 3-4=-1403/307, 4-5=-1286/360, 5-6=-430/132,
6-7=-497/120, 7-8=-1107/235
BOT CHORD 2-13=-655/2199, 12-13=-654/2204, 9-10=-220/907
WEBS 3-13=0/348, 3-12=-1156/384, 10-12=-206/1037, 5-12=-364/1084, 5-10=-270/135,
5-9=-752/219, 7-9=-176/945

NOTES-

- Unbalanced roof live loads have been considered for this design.
- Wind: ASCE 7-16; Vult=130mph (3-second gust) Vasd=101mph; TC DL=4.2psf; BCDL=3.0psf; h=18ft; Cat. II; Exp B; Encl., GCp=0.18; MWFRS (envelope) gable end zone and C-C Exterior(2E) 0-1-12 to 3-1-12, Interior(1) 3-1-12 to 17-0-0, Exterior(2R) 17-0-0 to 21-2-15, Interior(1) 21-2-15 to 24-5-0, Exterior(2E) 24-5-0 to 27-9-12 zone; C-C for members and forces & MWFRS for reactions shown; Lumber DOL=1.60 plate grip DOL=1.60
- Building Designer / Project engineer responsible for verifying applied roof live load shown covers rain loading requirements specific to the use of this truss component.
- Provide adequate drainage to prevent water ponding.
- This truss has been designed for a 10.0 psf bottom chord live load nonconcurrent with any other live loads.
- * This truss has been designed for a live load of 20.0psf on the bottom chord in all areas where a rectangle 3-6-0 tall by 2-0-0 wide will fit between the bottom chord and any other members, with BCDL = 10.0psf.
- Provide mechanical connection (by others) of truss to bearing plate capable of withstanding 100 lb uplift at joint(s) except (jt=lb) 1=212, 8=210.

This item has been electronically signed and sealed by O'Regan, Philip, PE using a Digital Signature. Printed copies of this document are not considered signed and sealed and the signature must be verified on any electronic copies.

Philip J. O'Regan PE No.58126
MiTek Inc. DBA MiTek USA FL Cert 6634
16023 Swingley Ridge Rd. Chesterfield, MO 63017
Date:

August 4, 2023

WARNING - Verify design parameters and READ NOTES ON THIS AND INCLUDED MITEK REFERENCE PAGE MII-7473 rev. 1/2/2023 BEFORE USE.

Design valid for use only with MiTek® connectors. This design is based only upon parameters shown, and is for an individual building component, not a truss system. Before use, the building designer must verify the applicability of design parameters and properly incorporate this design into the overall building design. Bracing indicated is to prevent buckling of individual truss web and/or chord members only. Additional temporary and permanent bracing is always required for stability and to prevent collapse with possible personal injury and property damage. For general guidance regarding the fabrication, storage, delivery, erection and bracing of trusses and truss systems, see **ANSI/TPI1 Quality Criteria and DSB-22** available from Truss Plate Institute (www.tpinst.org) and **BCSI Building Component Safety Information** available from the Structural Building Component Association (www.sbcsccomponents.com)

MiTek®

16023 Swingley Ridge Rd.
Chesterfield, MO 63017
314.434.1200 / MiTek-US.com

Job 3626267	Truss T12	Truss Type PIGGYBACK BASE	Qty 1	Ply 1	JT BLDRS - LOT 12 CCP	T31220146
----------------	--------------	------------------------------	----------	----------	-----------------------	-----------

Builders FirstSource, Lake City, FL 32055

8.530 s May 26 2022 MiTek Industries, Inc. Fri Aug 4 10:50:49 2023 Page 1
 ID:2eRY39KFhR2benj7cX?4RUzckGi-YuTLdNwND8ycFZVwKv0P1DumbJ6fpgL9xQ8JjyrPza

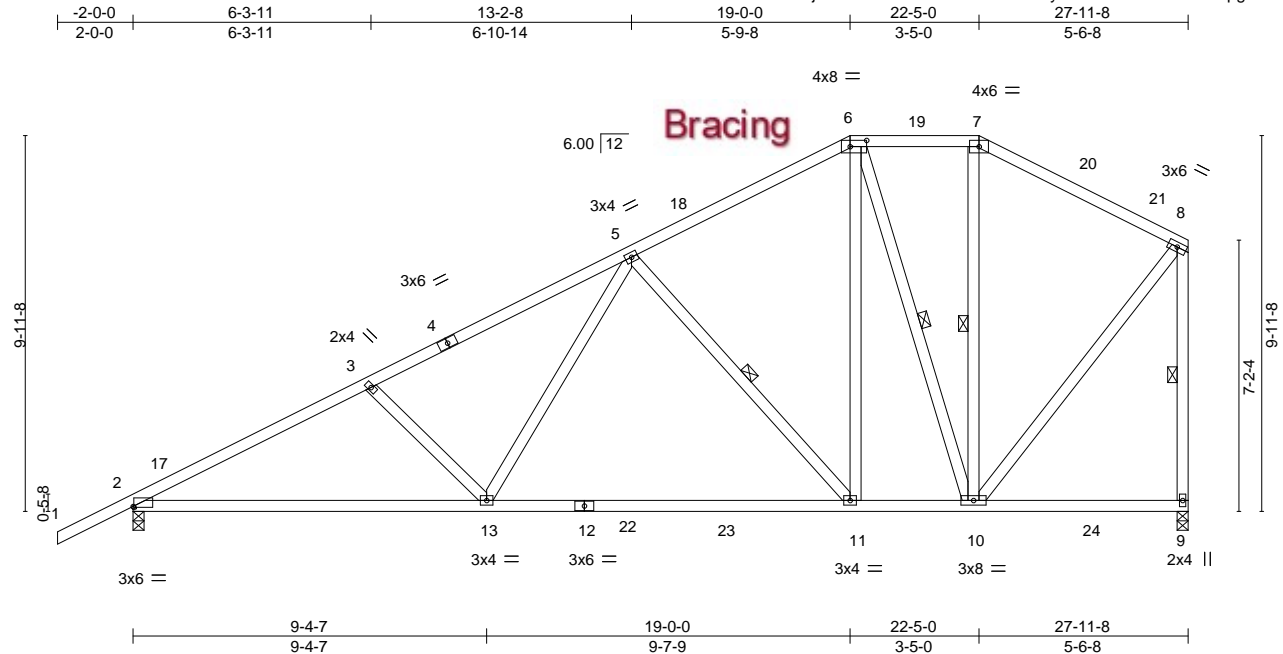

Plate Offsets (X,Y)--	[2:0-0-4,0-0-5], [6:0-5-4,0-2-0]
-----------------------	----------------------------------

LOADING (psf)	SPACING-	2-0-0	CSI.	DEFL.	in (loc)	l/defl	L/d	PLATES	GRIP
TCLL 20.0	Plate Grip DOL	1.25	TC 0.44	Vert(LL)	-0.33	11-13	>999	MT20	244/190
TCDL 7.0	Lumber DOL	1.25	BC 0.84	Vert(CT)	-0.54	11-13	>621		
BCLL 0.0 *	Rep Stress Incr	YES	WB 0.36	Horz(CT)	0.04	9	n/a		
BCDL 10.0	Code	FBC2020/TPI2014	Matrix-MS					Weight: 187 lb	FT = 20%

LUMBER-	BRACING-
TOP CHORD 2x4 SP No.2	TOP CHORD Structural wood sheathing directly applied or 4-1-9 oc purlins, except end verticals.
BOT CHORD 2x4 SP No.2 *Except 2-12: 2x4 SP No.1	BOT CHORD Rigid ceiling directly applied or 8-7-3 oc bracing.
WEBS 2x4 SP No.3	WEBS 1 Row at midpt 5-11, 6-10, 7-10, 8-9

REACTIONS. (size) 2=0-3-8, 9=0-3-8
 Max Horz 2=295(LC 12)
 Max Uplift 2=-253(LC 12), 9=-214(LC 12)
 Max Grav 2=1222(LC 2), 9=1161(LC 2)

FORCES. (lb) - Max. Comp./Max. Ten. - All forces 250 (lb) or less except when shown.
 TOP CHORD 2-3=-1954/368, 3-5=-1755/332, 5-6=-887/206, 6-7=-535/176, 7-8=-649/164, 8-9=-1038/244
 BOT CHORD 2-13=-532/1700, 11-13=-344/1177, 10-11=-166/745
 WEBS 3-13=-330/202, 5-13=-96/674, 5-11=-674/273, 6-11=-159/815, 6-10=-683/179, 8-10=-172/837

- NOTES-**
- Unbalanced roof live loads have been considered for this design.
 - Wind: ASCE 7-16; Vult=130mph (3-second gust) Vasd=101mph; TCDL=4.2psf; BCDL=3.0psf; h=18ft; Cat. II; Exp B; Encl., GCpi=0.18; MWFRS (envelope) gable end zone and C-C Exterior(2E) -2-0-0 to 1-0-0, Interior(1) 1-0-0 to 19-0-0, Exterior(2E) 19-0-0 to 22-5-0, Exterior(2R) 22-5-0 to 26-7-15, Interior(1) 26-7-15 to 27-9-12 zone; C-C for members and forces & MWFRS for reactions shown; Lumber DOL=1.60 plate grip DOL=1.60
 - Building Designer / Project engineer responsible for verifying applied roof live load shown covers rain loading requirements specific to the use of this truss component.
 - Provide adequate drainage to prevent water ponding.
 - This truss has been designed for a 10.0 psf bottom chord live load nonconcurrent with any other live loads.
 - * This truss has been designed for a live load of 20.0psf on the bottom chord in all areas where a rectangle 3-6-0 tall by 2-0-0 wide will fit between the bottom chord and any other members, with BCDL = 10.0psf.
 - Provide mechanical connection (by others) of truss to bearing plate capable of withstanding 100 lb uplift at joint(s) except (jt=lb) 2=253, 9=214.

This item has been electronically signed and sealed by O'Regan, Philip, PE using a Digital Signature. Printed copies of this document are not considered signed and sealed and the signature must be verified on any electronic copies.

Philip J. O'Regan PE No.58126
 MiTek Inc. DBA MiTek USA FL Cert 6634
 16023 Swingley Ridge Rd. Chesterfield, MO 63017
 Date:

August 4, 2023

WARNING - Verify design parameters and READ NOTES ON THIS AND INCLUDED MITEK REFERENCE PAGE MII-7473 rev. 1/2/2023 BEFORE USE.

Design valid for use only with MiTek® connectors. This design is based only upon parameters shown, and is for an individual building component, not a truss system. Before use, the building designer must verify the applicability of design parameters and properly incorporate this design into the overall building design. Bracing indicated is to prevent buckling of individual truss web and/or chord members only. Additional temporary and permanent bracing is always required for stability and to prevent collapse with possible personal injury and property damage. For general guidance regarding the fabrication, storage, delivery, erection and bracing of trusses and truss systems, see **ANSI/TPI1 Quality Criteria and DSB-22** available from Truss Plate Institute (www.tpinst.org) and **BCSI Building Component Safety Information** available from the Structural Building Component Association (www.sbcsccomponents.com)

MiTek®

16023 Swingley Ridge Rd.
 Chesterfield, MO 63017
 314.434.1200 / MiTek-US.com

Job 3626267	Truss T13	Truss Type HALF HIP GIRDER	Qty 1	Ply 3	JT BLDRS - LOT 12 CCP	T31220147
----------------	--------------	-------------------------------	----------	----------	-----------------------	-----------

Builders FirstSource, Lake City, FL 32055

ID:2eRY39KFhR2benj7cX?4RUzckGi-yT9TFOzpf8WXTJl4bSTj1frJ4oNqs0cnrvfow2yrPzX
8.530 s May 26 2022 MiTek Industries, Inc. Fri Aug 4 10:50:52 2023 Page 1

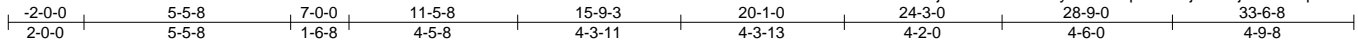

Scale = 1:60.9

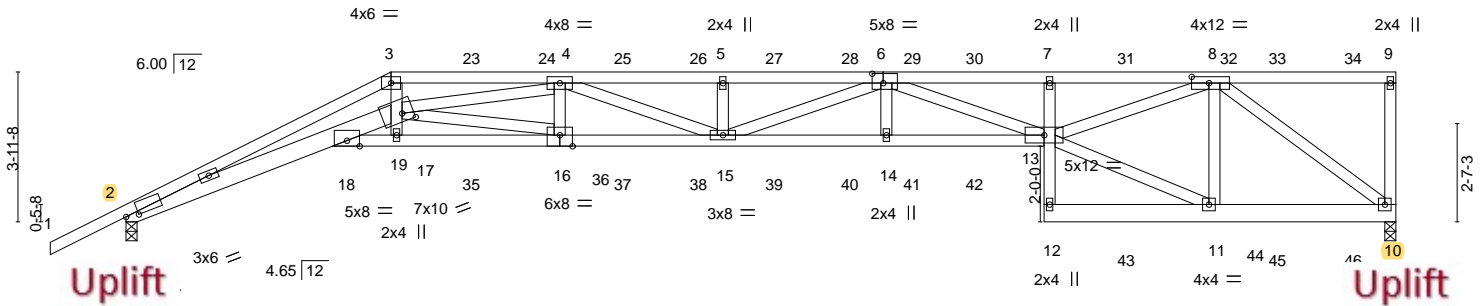

Plate Offsets (X,Y)--	[2:0-4-1,0-0-12], [6:0-3-8,0-3-0], [8:0-5-8,0-2-0], [16:0-4-0,Edge], [19:0-3-10,0-2-9]
-----------------------	--

LOADING (psf)	SPACING-	CSI.	DEFL.	PLATES	GRIP
TCLL 20.0	2-0-0	TC 0.82	in (loc) l/defl L/d	MT20	244/190
TCDL 7.0	Plate Grip DOL 1.25	BC 0.64	Vert(LL) -0.61 15 >653 240		
BCLL 0.0 *	Lumber DOL 1.25	WB 0.99	Vert(CT) -1.15 15 >349 180		
BCDL 10.0	Rep Stress Incr NO	Matrix-MS	Horz(CT) 0.60 10 n/a n/a		
	Code FBC2020/TPI2014			Weight: 590 lb	FT = 20%

LUMBER-

TOP CHORD 2x4 SP No.2
 BOT CHORD 2x4 SP 2850F 2.0E or 2x4 SP M 31 *Except*
 2-19: 2x6 SP M 26, 7-12: 2x4 SP No.3, 10-12: 2x6 SP No.2
 WEBS 2x4 SP No.3 *Except*
 3-17,4-16,5-15,6-14: 2x4 SP No.2

BRACING-

TOP CHORD Structural wood sheathing directly applied or 5-3-15 oc purlins, except end verticals.
 BOT CHORD Rigid ceiling directly applied or 10-0-0 oc bracing.

REACTIONS.

(size) 10=0-3-8, 2=0-3-8
 Max Horz 2=146(LC 8)
 Max Uplift 10=-772(LC 5), 2=-778(LC 8)
 Max Grav 10=2690(LC 1), 2=2579(LC 1)

FORCES. (lb) - Max. Comp./Max. Ten. - All forces 250 (lb) or less except when shown.

TOP CHORD 2-3=-12072/3795, 3-4=-10899/3462, 4-5=-13546/4157, 5-6=-13546/4157,
 6-7=-10721/3200, 7-8=-10401/3109
 BOT CHORD 2-18=-3578/11210, 18-19=-1439/4447, 17-18=-2305/7311, 16-17=-2539/8039,
 15-16=-3877/12563, 14-15=-4012/13187, 13-14=-4016/13201, 7-13=-390/192,
 11-12=-88/309, 10-11=-903/3112
 WEBS 3-19=-1522/4912, 4-19=-1835/630, 4-16=-659/213, 4-15=-327/1121, 5-15=-373/139,
 6-15=-239/386, 6-14=-72/276, 6-13=-2652/913, 11-13=-890/3063, 8-13=-2362/7805,
 8-11=-1028/451, 8-10=-3888/1126, 16-19=-1364/4522

NOTES-

- 3-ply truss to be connected together with 10d (0.131"x3") nails as follows:
 Top chords connected as follows: 2x4 - 1 row at 0-9-0 oc.
 Bottom chords connected as follows: 2x6 - 2 rows staggered at 0-9-0 oc, 2x4 - 1 row at 0-9-0 oc.
 Webs connected as follows: 2x4 - 1 row at 0-9-0 oc.
- All loads are considered equally applied to all plies, except if noted as front (F) or back (B) face in the LOAD CASE(S) section. Ply to ply connections have been provided to distribute only loads noted as (F) or (B), unless otherwise indicated.
- Unbalanced roof live loads have been considered for this design.
- Wind: ASCE 7-16; Vult=130mph (3-second gust) Vasd=101mph; TC DL=4.2psf; BCDL=3.0psf; h=18ft; Cat. II; Exp B; Encl., GCp=0.18; MWFRS (envelope) gable end zone; Lumber DOL=1.60 plate grip DOL=1.60
- Building Designer / Project engineer responsible for verifying applied roof live load shown covers rain loading requirements specific to the use of this truss component.
- Provide adequate drainage to prevent water ponding.
- This truss has been designed for a 10.0 psf bottom chord live load nonconcurrent with any other live loads.
- * This truss has been designed for a live load of 20.0psf on the bottom chord in all areas where a rectangle 3-6-0 tall by 2-0-0 wide will fit between the bottom chord and any other members.
- Bearing at joint(s) 2 considers parallel to grain value using ANSI/TPI 1 angle to grain formula. Building designer should verify capacity of bearing surface.
- Provide mechanical connection (by others) of truss to bearing plate capable of withstanding 100 lb uplift at joint(s) except (jt=lb) 10=772, 2=778.

This item has been electronically signed and sealed by O'Regan, Philip, PE using a Digital Signature. Printed copies of this document are not considered signed and sealed and the signature must be verified on any electronic copies.

Philip J. O'Regan PE No.58126
 MiTek Inc. DBA MiTek USA FL Cert 6634
 16023 Swingley Ridge Rd. Chesterfield, MO 63017
 Date:

August 4, 2023

Continued on page 2

WARNING - Verify design parameters and READ NOTES ON THIS AND INCLUDED MITEK REFERENCE PAGE MII-7473 rev. 1/2/2023 BEFORE USE.

Design valid for use only with MiTek® connectors. This design is based only upon parameters shown, and is for an individual building component, not a truss system. Before use, the building designer must verify the applicability of design parameters and properly incorporate this design into the overall building design. Bracing indicated is to prevent buckling of individual truss web and/or chord members only. Additional temporary and permanent bracing is always required for stability and to prevent collapse with possible personal injury and property damage. For general guidance regarding the fabrication, storage, delivery, erection and bracing of trusses and truss systems, see **ANSI/TPI1 Quality Criteria and DSB-22** available from Truss Plate Institute (www.tpinst.org) and **BCSI Building Component Safety Information** available from the Structural Building Component Association (www.sbcsccomponents.com)

MiTek®

16023 Swingley Ridge Rd.
 Chesterfield, MO 63017
 314.434.1200 / MiTek-US.com

Job 3626267	Truss T13	Truss Type HALF HIP GIRDER	Qty 1	Ply 3	JT BLDRS - LOT 12 CCP Job Reference (optional)	T31220147
----------------	--------------	-------------------------------	----------	----------	---	-----------

Builders FirstSource, Lake City, FL 32055

8.530 s May 26 2022 MiTek Industries, Inc. Fri Aug 4 10:50:52 2023 Page 2
ID:2eRY39KFhR2benj7cX?4RUzckGi-yT9TFOzpf8WXTJl4bSTj1frJ4oNqs0cnrvfow2yrPzX

NOTES-

11) Hanger(s) or other connection device(s) shall be provided sufficient to support concentrated load(s) 124 lb down and 56 lb up at 7-0-0, 109 lb down and 56 lb up at 9-0-12, 109 lb down and 56 lb up at 11-0-12, 109 lb down and 56 lb up at 13-0-12, 109 lb down and 56 lb up at 15-0-12, 109 lb down and 56 lb up at 17-0-12, 109 lb down and 56 lb up at 19-0-12, 109 lb down and 52 lb up at 20-8-8, 109 lb down and 56 lb up at 22-4-4, 107 lb down and 87 lb up at 24-4-4, 107 lb down and 87 lb up at 26-4-4, 107 lb down and 87 lb up at 28-4-4, and 107 lb down and 87 lb up at 30-4-4, and 107 lb down and 87 lb up at 32-4-4 on top chord, and 412 lb down and 199 lb up at 7-1-12, 62 lb down and 46 lb up at 9-0-12, 62 lb down and 46 lb up at 11-0-12, 62 lb down and 46 lb up at 13-0-12, 62 lb down and 46 lb up at 15-0-12, 62 lb down and 46 lb up at 17-0-12, 62 lb down and 46 lb up at 19-0-12, 62 lb down and 46 lb up at 20-8-8, 62 lb down and 46 lb up at 22-4-4, 85 lb down at 24-4-12, 85 lb down at 26-4-4, 85 lb down at 28-4-4, and 85 lb down at 30-4-4, and 85 lb down at 32-4-4 on bottom chord. The design/selection of such connection device(s) is the responsibility of others.

LOAD CASE(S) Standard

1) Dead + Roof Live (balanced): Lumber Increase=1.25, Plate Increase=1.25

Uniform Loads (plf)

Vert: 1-3=-54, 3-9=-54, 18-20=-20, 13-18=-20, 10-12=-20

Concentrated Loads (lb)

Vert: 3=-105(B) 7=-107(B) 19=-412(B) 13=-60(B) 23=-105(B) 24=-105(B) 25=-105(B) 26=-105(B) 27=-105(B) 28=-105(B) 29=-105(B) 30=-105(B) 31=-107(B) 32=-107(B) 33=-107(B) 34=-107(B) 35=-62(B) 36=-62(B) 37=-62(B) 38=-62(B) 39=-62(B) 40=-62(B) 41=-62(B) 42=-62(B) 43=-60(B) 44=-60(B) 45=-60(B) 46=-60(B)

WARNING - Verify design parameters and READ NOTES ON THIS AND INCLUDED MITEK REFERENCE PAGE MII-7473 rev. 1/2/2023 BEFORE USE.

Design valid for use only with MiTek® connectors. This design is based only upon parameters shown, and is for an individual building component, not a truss system. Before use, the building designer must verify the applicability of design parameters and properly incorporate this design into the overall building design. Bracing indicated is to prevent buckling of individual truss web and/or chord members only. Additional temporary and permanent bracing is always required for stability and to prevent collapse with possible personal injury and property damage. For general guidance regarding the fabrication, storage, delivery, erection and bracing of trusses and truss systems, see **ANSI/TPI1 Quality Criteria and DSB-22** available from Truss Plate Institute (www.tpinst.org) and **BCSI Building Component Safety Information** available from the Structural Building Component Association (www.sbcsccomponents.com)

MiTek®

16023 Swingley Ridge Rd.
Chesterfield, MO 63017
314.434.1200 / MiTek-US.com

Job 3626267	Truss T14	Truss Type HIP	Qty 1	Ply 1	JT BLDRS - LOT 12 CCP	T31220148
----------------	--------------	-------------------	----------	----------	-----------------------	-----------

Builders FirstSource, Lake City, FL 32055

8.530 s May 26 2022 MiTek Industries, Inc. Fri Aug 4 10:50:53 2023 Page 1
ID:2eRY39KFhR2benj7cX?4RUzckGi-QfjsTk_RQSF05stH9A_yasOS4CfZbYnx4ZOMSUyrPzW

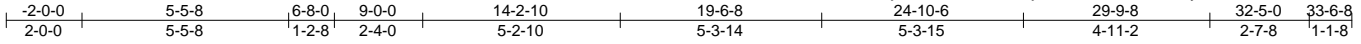

Scale = 1:60.9

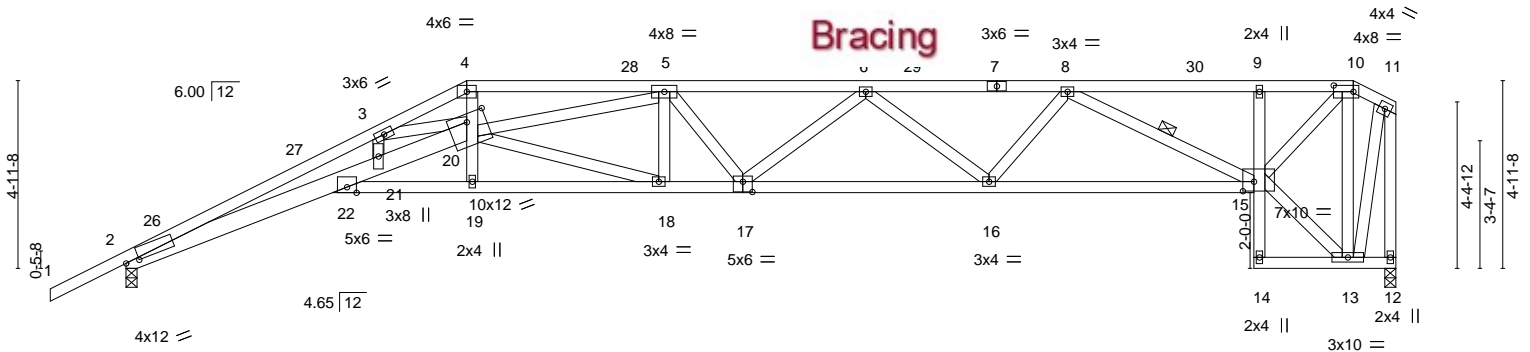

Plate Offsets (X,Y)--	[2:0-4-5-0-0-7],	[10:0-6-4-0-2-0],	[15:0-3-8,0-3-0],	[17:0-3-0,0-3-4],	[20:0-6-0,0-2-8]
-----------------------	------------------	-------------------	-------------------	-------------------	------------------

LOADING (psf)	SPACING-	CSL	DEFL.	PLATES	GRIP
TCLL 20.0	2-0-0	TC 0.93	in (loc) l/defl L/d	MT20	244/190
TCDL 7.0	Plate Grip DOL 1.25	BC 0.93	Vert(LL) -0.48 18 >839 240		
BCLL 0.0 *	Lumber DOL 1.25	WB 0.68	Vert(CT) -0.90 18-19 >444 180		
BCDL 10.0	Rep Stress Incr YES	Matrix-MS	Horz(CT) 0.60 12 n/a n/a		
	Code FBC2020/TPI2014			Weight: 209 lb	FT = 20%

LUMBER-	BRACING-
TOP CHORD 2x4 SP No.2	TOP CHORD Structural wood sheathing directly applied, except end verticals.
BOT CHORD 2x4 SP No.2 *Except*	BOT CHORD Rigid ceiling directly applied or 2-2-0 oc bracing.
2-20: 2x6 SP M 26, 9-14: 2x4 SP No.3	WEBS 1 Row at midpt 8-15
WEBS 2x4 SP No.3	

REACTIONS. (size) 2=0-3-8, 12=0-3-8
 Max Horz 2=170(LC 12)
 Max Uplift 2=-315(LC 12), 12=-284(LC 9)
 Max Grav 2=1347(LC 1), 12=1232(LC 1)

FORCES. (lb) - Max. Comp./Max. Ten. - All forces 250 (lb) or less except when shown.
 TOP CHORD 2-3=-5988/1506, 3-4=-3273/783, 4-5=-2908/713, 5-6=-3832/914, 6-8=-3336/796,
 8-9=-1486/368, 9-10=-1444/360, 10-11=-344/83, 11-12=-1173/272
 BOT CHORD 2-22=-1489/5596, 21-22=-766/2685, 20-21=-681/2312, 19-22=-771/3151,
 18-19=-767/3156, 17-18=-917/3821, 16-17=-929/3754, 15-16=-740/2954
 WEBS 4-20=-267/1261, 5-20=-999/298, 6-16=-542/230, 8-16=-126/623, 8-15=-1660/426,
 13-15=-56/282, 10-15=-442/1776, 10-13=-1163/292, 11-13=-231/983, 18-20=-244/797,
 3-20=-2409/703, 3-21=-235/1033

- NOTES-**
- 1) Unbalanced roof live loads have been considered for this design.
 - 2) Wind: ASCE 7-16; Vult=130mph (3-second gust) Vasd=101mph; TCDL=4.2psf; BCDL=3.0psf; h=18ft; Cat. II; Exp B; Encl., GCpi=0.18; MWFRS (envelope) gable end zone and C-C Exterior(2E) -2-0-0 to 1-0-0, Interior(1) 1-0-0 to 9-0-0, Exterior(2R) 9-0-0 to 13-2-15, Interior(1) 13-2-15 to 32-5-0, Exterior(2E) 32-5-0 to 33-4-12 zone; C-C for members and forces & MWFRS for reactions shown; Lumber DOL=1.60 plate grip DOL=1.60
 - 3) Building Designer / Project engineer responsible for verifying applied roof live load shown covers rain loading requirements specific to the use of this truss component.
 - 4) Provide adequate drainage to prevent water ponding.
 - 5) This truss has been designed for a 10.0 psf bottom chord live load nonconcurrent with any other live loads.
 - 6) * This truss has been designed for a live load of 20.0psf on the bottom chord in all areas where a rectangle 3-6-0 tall by 2-0-0 wide will fit between the bottom chord and any other members.
 - 7) Bearing at joint(s) 2 considers parallel to grain value using ANSI/TPI 1 angle to grain formula. Building designer should verify capacity of bearing surface.
 - 8) Provide mechanical connection (by others) of truss to bearing plate capable of withstanding 100 lb uplift at joint(s) except (jt=lb) 2=315, 12=284.

This item has been electronically signed and sealed by O'Regan, Philip, PE using a Digital Signature. Printed copies of this document are not considered signed and sealed and the signature must be verified on any electronic copies.

Philip J. O'Regan PE No.58126
 MiTek Inc. DBA MiTek USA FL Cert 6634
 16023 Swingley Ridge Rd. Chesterfield, MO 63017
 Date:

August 4, 2023

WARNING - Verify design parameters and READ NOTES ON THIS AND INCLUDED MITEK REFERENCE PAGE MII-7473 rev. 1/2/2023 BEFORE USE.

Design valid for use only with MiTek® connectors. This design is based only upon parameters shown, and is for an individual building component, not a truss system. Before use, the building designer must verify the applicability of design parameters and properly incorporate this design into the overall building design. Bracing indicated is to prevent buckling of individual truss web and/or chord members only. Additional temporary and permanent bracing is always required for stability and to prevent collapse with possible personal injury and property damage. For general guidance regarding the fabrication, storage, delivery, erection and bracing of trusses and truss systems, see **ANSI/TPI1 Quality Criteria and DSB-22** available from Truss Plate Institute (www.tpinst.org) and **BCSI Building Component Safety Information** available from the Structural Building Component Association (www.sbcsccomponents.com)

MiTek®

16023 Swingley Ridge Rd.
 Chesterfield, MO 63017
 314.434.1200 / MiTek-US.com

Job 3626267	Truss T15	Truss Type HIP	Qty 1	Ply 1	JT BLDRS - LOT 12 CCP	T31220149
----------------	--------------	-------------------	----------	----------	-----------------------	-----------

Builders FirstSource, Lake City, FL 32055

ID:2eRY39KFhR2benj7cX?4RUzckGi-urHEg4_3BmnEjOSTjtVB64xdLc0hK_g4JD8v?wyrPzV
8.530 s May 26 2022 MiTek Industries, Inc. Fri Aug 4 10:50:54 2023 Page 1

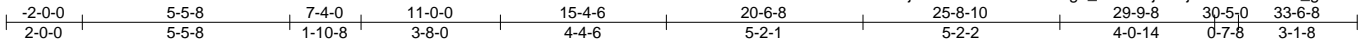

Scale = 1:60.6

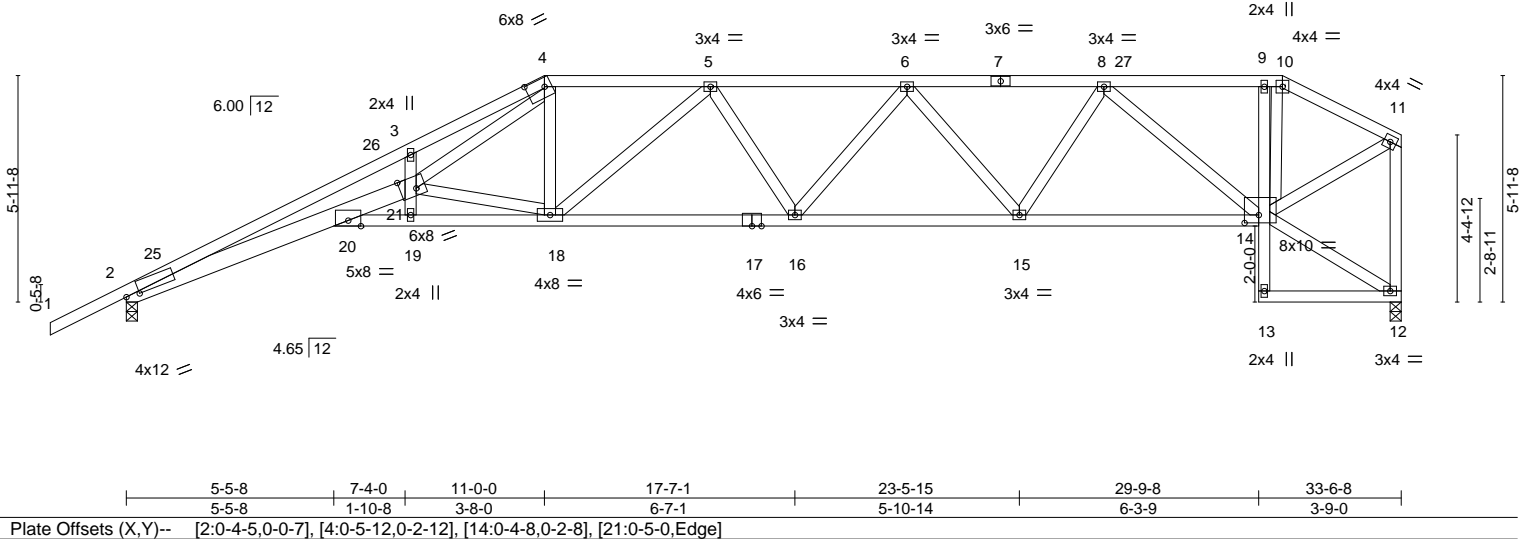

LOADING (psf)	SPACING-	2-0-0	CSI.	DEFL.	in (loc)	l/defl	L/d	PLATES	GRIP
TCLL 20.0	Plate Grip DOL	1.25	TC 0.90	Vert(LL)	-0.46	20-21	>874	MT20	244/190
TCDL 7.0	Lumber DOL	1.25	BC 0.87	Vert(CT)	-0.86	20-21	>468		
BCLL 0.0 *	Rep Stress Incr	YES	WB 0.76	Horz(CT)	0.55	12	n/a		
BCDL 10.0	Code	FBC2020/TPI2014	Matrix-MS					Weight: 206 lb	FT = 20%

LUMBER-	BRACING-
TOP CHORD 2x4 SP No.2 *Except* 1-4: 2x4 SP No.1	TOP CHORD Structural wood sheathing directly applied or 1-9-15 oc purlins, except end verticals.
BOT CHORD 2x4 SP No.2 *Except* 2-21: 2x6 SP M 26, 9-13: 2x4 SP No.3	BOT CHORD Rigid ceiling directly applied or 6-0-0 oc bracing.
WEBS 2x4 SP No.3 *Except* 3-19,4-21: 2x4 SP No.2	

REACTIONS.	(size) 2=0-3-8, 12=0-3-8 Max Horz 2=184(LC 12) Max Uplift 2=-311(LC 12), 12=-237(LC 8) Max Grav 2=1347(LC 1), 12=1232(LC 1)
-------------------	--

FORCES.	(lb) - Max. Comp./Max. Ten. - All forces 250 (lb) or less except when shown.
TOP CHORD	2-3=-5635/1412, 3-4=-5306/1407, 4-5=-2521/621, 5-6=-2783/632, 6-8=-2335/535, 8-9=-1065/243, 9-10=-1048/242, 10-11=-1150/248, 11-12=-1197/251
BOT CHORD	2-20=-1407/5245, 20-21=-829/2994, 19-20=-616/2443, 18-19=-702/2742, 16-18=-636/2794, 15-16=-622/2676, 14-15=-467/2000
WEBS	18-21=-259/115, 4-18=-95/466, 5-18=-478/184, 6-15=-549/194, 8-15=-131/652, 8-14=-1247/318, 11-14=-247/1168, 10-14=-123/458, 4-21=-835/2814

- NOTES-**
- Unbalanced roof live loads have been considered for this design.
 - Wind: ASCE 7-16; Vult=130mph (3-second gust) Vasd=101mph; TC DL=4.2psf; BCDL=3.0psf; h=18ft; Cat. II; Exp B; Encl., GCpi=0.18; MWFRS (envelope) gable end zone and C-C Exterior(2E) -2-0-0 to 1-0-0, Interior(1) 1-0-0 to 11-0-0, Exterior(2R) 11-0-0 to 15-4-6, Interior(1) 15-4-6 to 30-5-0, Exterior(2E) 30-5-0 to 33-4-12 zone;C-C for members and forces & MWFRS for reactions shown; Lumber DOL=1.60 plate grip DOL=1.60
 - Building Designer / Project engineer responsible for verifying applied roof live load shown covers rain loading requirements specific to the use of this truss component.
 - Provide adequate drainage to prevent water ponding.
 - This truss has been designed for a 10.0 psf bottom chord live load nonconcurrent with any other live loads.
 - * This truss has been designed for a live load of 20.0psf on the bottom chord in all areas where a rectangle 3-6-0 tall by 2-0-0 wide will fit between the bottom chord and any other members.
 - Bearing at joint(s) 2 considers parallel to grain value using ANSI/TPI 1 angle to grain formula. Building designer should verify capacity of bearing surface.
 - Provide mechanical connection (by others) of truss to bearing plate capable of withstanding 100 lb uplift at joint(s) except (jt=lb) 2=311, 12=237.

This item has been electronically signed and sealed by O'Regan, Philip, PE using a Digital Signature. Printed copies of this document are not considered signed and sealed and the signature must be verified on any electronic copies.

Philip J. O'Regan PE No.58126
MiTek Inc. DBA MiTek USA FL Cert 6634
16023 Swingley Ridge Rd. Chesterfield, MO 63017
Date:

August 4, 2023

WARNING - Verify design parameters and READ NOTES ON THIS AND INCLUDED MITEK REFERENCE PAGE MII-7473 rev. 1/2/2023 BEFORE USE.

Design valid for use only with MiTek® connectors. This design is based only upon parameters shown, and is for an individual building component, not a truss system. Before use, the building designer must verify the applicability of design parameters and properly incorporate this design into the overall building design. Bracing indicated is to prevent buckling of individual truss web and/or chord members only. Additional temporary and permanent bracing is always required for stability and to prevent collapse with possible personal injury and property damage. For general guidance regarding the fabrication, storage, delivery, erection and bracing of trusses and truss systems, see ANSI/TPI1 Quality Criteria and DSB-22 available from Truss Plate Institute (www.tpinst.org) and BCSI Building Component Safety Information available from the Structural Building Component Association (www.sbcsccomponents.com)

MiTek®

16023 Swingley Ridge Rd.
Chesterfield, MO 63017
314.434.1200 / MiTek-US.com

Job	Truss	Truss Type	Qty	Ply	Material	Job Reference (optional)
3626267	T16	HIP	1	1	JT BLDRS - LOT 12 CCP	T31220150

Builders FirstSource, Lake City, FL 32055

ID:2eRY39KfHr2benj7cX?4RUzckGi-N2rcuQ?hy3v5KA1fHb0QfHTuA00j3PAEXttXMyrPzU

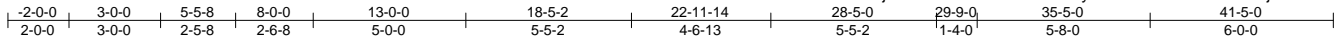

Scale = 1:75.5

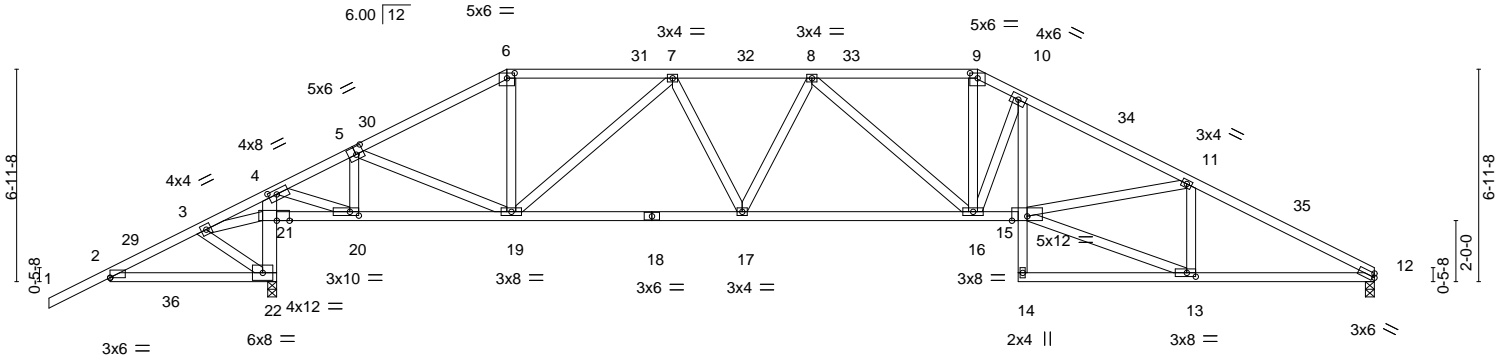

Plate Offsets (X,Y)--	[2:0-0,0-0-1], [4:0-3-4,0-1-12], [5:0-3-0,0-2-0], [6:0-3-0,0-2-0], [9:0-3-0,0-2-0], [13:0-3-8,0-1-8], [20:0-3-8,0-1-8], [21:0-5-0,0-0-0]
-----------------------	--

LOADING (psf)	SPACING-	TC	BC	WB	Matrix	DEFL.	in (loc)	l/defl	L/d	PLATES	GRIP
TCLL 20.0	Plate Grip DOL 2-0-0	2.00	0.58	0.76	MS	Vert(LL)	-0.20	15-16	>999	MT20	244/190
TCDL 7.0	Lumber DOL 1.25		0.76	180		Vert(CT)	-0.41	16-17	>999		
BCLL 0.0 *	Rep Stress Incr YES		0.88	180		Horz(CT)	0.16	12	n/a		
BCDL 10.0	Code FBC2020/TPI2014									Weight: 241 lb	FT = 20%

LUMBER-	BRACING-
TOP CHORD 2x4 SP No.2	TOP CHORD Structural wood sheathing directly applied or 3-0-11 oc purlins.
BOT CHORD 2x4 SP No.2 *Except* 4-22: 2x6 SP No.2, 10-14: 2x4 SP No.3	BOT CHORD Rigid ceiling directly applied or 3-11-8 oc bracing.
WEBS 2x4 SP No.3 *Except* 4-20: 2x4 SP No.2	

REACTIONS.
(size) 12=0-3-8, 22=0-3-8
Max Horz 22=123(LC 16)
Max Uplift 12=-283(LC 13), 22=-404(LC 12)
Max Grav 12=1292(LC 1), 22=1880(LC 1)

FORCES.	(lb) - Max. Comp./Max. Ten. - All forces 250 (lb) or less except when shown.
TOP CHORD	2-3=-493/548, 3-4=-1557/1709, 4-5=-1171/252, 5-6=-1747/343, 6-7=-1522/325, 7-8=-2348/441, 8-9=-2300/512, 9-10=-2560/561, 10-11=-3006/618, 11-12=-2405/523
BOT CHORD	2-22=-452/496, 21-22=-1985/772, 4-21=-2172/1006, 20-21=-1952/1908, 19-20=-224/1026, 17-19=-385/2192, 16-17=-389/2428, 15-16=-391/2616, 10-15=-171/823, 12-13=-407/2087
WEBS	5-20=-746/439, 5-19=-433/667, 6-19=-56/559, 7-19=-911/244, 7-17=-95/360, 8-16=-314/153, 9-16=-181/965, 10-16=-903/263, 13-15=-431/2158, 11-15=-127/558, 11-13=-675/189, 4-20=-1514/2943, 3-22=-317/270, 3-21=-1285/1279

- NOTES-**
- Unbalanced roof live loads have been considered for this design.
 - Wind: ASCE 7-16; Vult=130mph (3-second gust) Vasd=101mph; TC DL=4.2psf; BCDL=3.0psf; h=18ft; Cat. II; Exp B; Encl., GCpi=0.18; MWFRS (envelope) gable end zone and C-C Exterior(2E) -2-0-0 to 1-0-0, Interior(1) 1-0-0 to 13-0-0, Exterior(2R) 13-0-0 to 17-2-15, Interior(1) 17-2-15 to 28-5-0, Exterior(2R) 28-5-0 to 32-7-15, Interior(1) 32-7-15 to 41-5-0 zone; cantilever left exposed ;C-C for members and forces & MWFRS for reactions shown; Lumber DOL=1.60 plate grip DOL=1.60
 - Building Designer / Project engineer responsible for verifying applied roof live load shown covers rain loading requirements specific to the use of this truss component.
 - Provide adequate drainage to prevent water ponding.
 - This truss has been designed for a 10.0 psf bottom chord live load nonconcurrent with any other live loads.
 - * This truss has been designed for a live load of 20.0psf on the bottom chord in all areas where a rectangle 3-6-0 tall by 2-0-0 wide will fit between the bottom chord and any other members.
 - Provide mechanical connection (by others) of truss to bearing plate capable of withstanding 100 lb uplift at joint(s) except (jt=lb) 12=283, 22=404.

This item has been electronically signed and sealed by O'Regan, Philip, PE using a Digital Signature. Printed copies of this document are not considered signed and sealed and the signature must be verified on any electronic copies.

Philip J. O'Regan PE No.58126
MiTek Inc. DBA MiTek USA FL Cert 6634
16023 Swingley Ridge Rd. Chesterfield, MO 63017
Date:

August 4, 2023

<p>WARNING - Verify design parameters and READ NOTES ON THIS AND INCLUDED MITEK REFERENCE PAGE MII-7473 rev. 1/2/2023 BEFORE USE.</p> <p>Design valid for use only with MiTek® connectors. This design is based only upon parameters shown, and is for an individual building component, not a truss system. Before use, the building designer must verify the applicability of design parameters and properly incorporate this design into the overall building design. Bracing indicated is to prevent buckling of individual truss web and/or chord members only. Additional temporary and permanent bracing is always required for stability and to prevent collapse with possible personal injury and property damage. For general guidance regarding the fabrication, storage, delivery, erection and bracing of trusses and truss systems, see ANSITPI Quality Criteria and DSB-22 available from Truss Plate Institute (www.tpinst.org) and BCSI Building Component Safety Information available from the Structural Building Component Association (www.sbccomponents.com)</p>	<p>16023 Swingley Ridge Rd. Chesterfield, MO 63017 314.434.1200 / MiTek-US.com</p>
--	--

Job 3626267	Truss T17	Truss Type HIP	Qty 1	Ply 1	JT BLDRS - LOT 12 CCP	T31220151
----------------	--------------	-------------------	----------	----------	-----------------------	-----------

Builders FirstSource, Lake City, FL 32055

8.530 s May 26 2022 MiTek Industries, Inc. Fri Aug 4 10:50:56 2023 Page 1
ID:2eRY39KFhR2benj7cX?4RUzckGi-rEO_5m0JN1yyKbsqlXfBV02hQIH0tPNmXd03pyrPzT

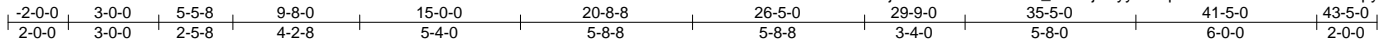

Scale = 1:76.4

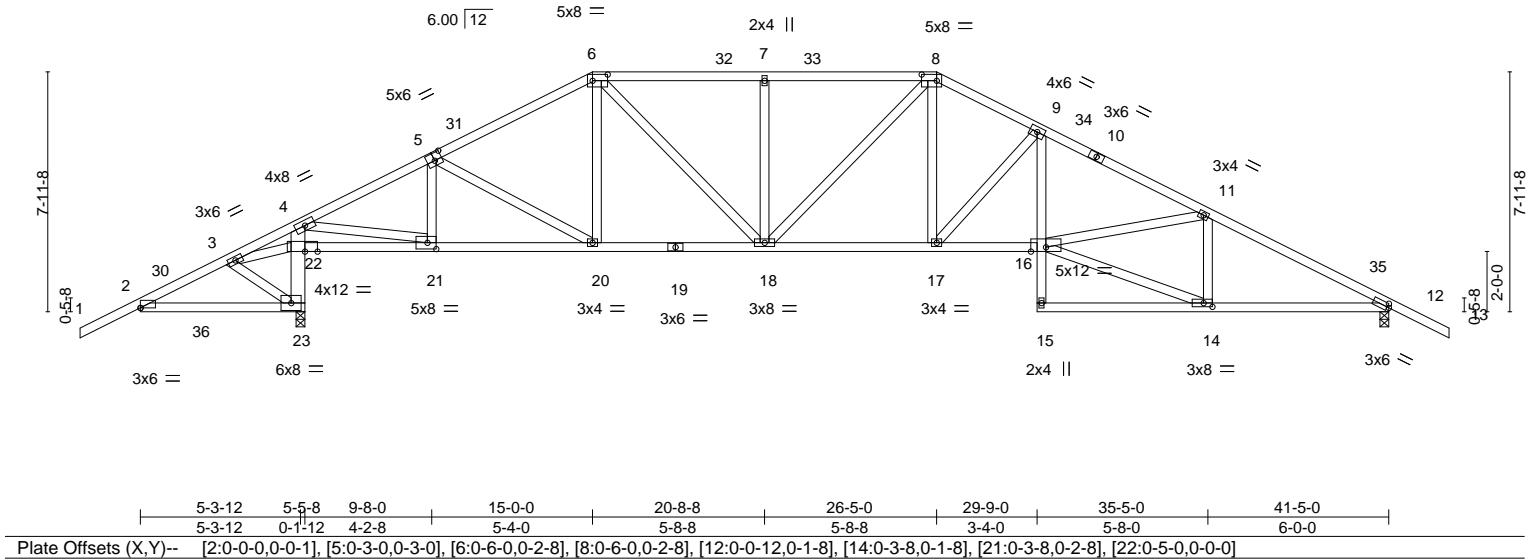

LOADING (psf)	SPACING-	CSI.	DEFL.	PLATES	GRIP
TCLL 20.0	Plate Grip DOL 2-0-0	TC 0.59	in (loc) l/defl L/d	MT20	244/190
TCDL 7.0	Lumber DOL 1.25	BC 0.67	Vert(LL) -0.19 16-17 >999 240		
BCLL 0.0 *	Rep Stress Incr YES	WB 0.81	Vert(CT) -0.35 16-17 >999 180		
BCDL 10.0	Code FBC2020/TP12014	Matrix-MS	Horz(CT) 0.11 12 n/a n/a		
				Weight: 250 lb	FT = 20%

LUMBER-

TOP CHORD 2x4 SP No.2
 BOT CHORD 2x4 SP No.2 *Except*
 4-23: 2x6 SP No.2, 9-15: 2x4 SP No.3
 WEBS 2x4 SP No.3 *Except*
 4-21: 2x4 SP No.2

BRACING-

TOP CHORD Structural wood sheathing directly applied or 3-0-3 oc purlins.
 BOT CHORD Rigid ceiling directly applied or 4-1-4 oc bracing.

REACTIONS.

(size) 12=0-3-8, 23=0-3-8
 Max Horz 23=123(LC 12)
 Max Uplift 12=-322(LC 13), 23=-400(LC 12)
 Max Grav 12=1403(LC 1), 23=1877(LC 1)

FORCES. (lb) - Max. Comp./Max. Ten. - All forces 250 (lb) or less except when shown.

TOP CHORD 2-3=-494/550, 3-4=-1598/1708, 4-5=-1490/257, 5-6=-1731/321, 6-7=-1953/384,
 7-8=-1953/384, 8-9=-2219/462, 9-11=-2997/582, 11-12=-2367/499
 BOT CHORD 2-23=-453/497, 22-23=-1985/784, 4-22=-2165/1034, 21-22=-1848/1939, 20-21=-193/1277,
 18-20=-167/1490, 17-18=-158/1961, 16-17=-332/2623, 9-16=-127/818, 12-14=-355/2049
 WEBS 4-21=-1694/3154, 5-20=-255/242, 6-18=-186/697, 7-18=-354/166, 8-17=-154/767,
 9-17=-1001/261, 14-16=-376/2134, 11-16=-82/581, 11-14=-680/176, 5-21=-462/333,
 3-23=-339/275, 3-22=-1287/1332

NOTES-

- Unbalanced roof live loads have been considered for this design.
- Wind: ASCE 7-16; Vult=130mph (3-second gust) Vasd=101mph; TCDL=4.2psf; BCDL=3.0psf; h=18ft; Cat. II; Exp B; Encl., GCpi=0.18; MWFRS (envelope) gable end zone and C-C Exterior(2E) -2-0-0 to 1-0-0, Interior(1) 1-0-0 to 15-0-0, Exterior(2R) 15-0-0 to 19-2-15, Interior(1) 19-2-15 to 26-5-0, Exterior(2R) 26-5-0 to 30-7-15, Interior(1) 30-7-15 to 43-5-0 zone; cantilever left exposed ;C-C for members and forces & MWFRS for reactions shown; Lumber DOL=1.60 plate grip DOL=1.60
- Building Designer / Project engineer responsible for verifying applied roof live load shown covers rain loading requirements specific to the use of this truss component.
- Provide adequate drainage to prevent water ponding.
- This truss has been designed for a 10.0 psf bottom chord live load nonconcurrent with any other live loads.
- * This truss has been designed for a live load of 20.0psf on the bottom chord in all areas where a rectangle 3-6-0 tall by 2-0-0 wide will fit between the bottom chord and any other members.
- Provide mechanical connection (by others) of truss to bearing plate capable of withstanding 100 lb uplift at joint(s) except (jt=lb) 12=322, 23=400.

This item has been electronically signed and sealed by O'Regan, Philip, PE using a Digital Signature. Printed copies of this document are not considered signed and sealed and the signature must be verified on any electronic copies.

Philip J. O'Regan PE No.58126
 MiTek Inc. DBA MiTek USA FL Cert 6634
 16023 Swingley Ridge Rd. Chesterfield, MO 63017
 Date:

August 4, 2023

WARNING - Verify design parameters and READ NOTES ON THIS AND INCLUDED MITEK REFERENCE PAGE MII-7473 rev. 1/2/2023 BEFORE USE.

Design valid for use only with MiTek® connectors. This design is based only upon parameters shown, and is for an individual building component, not a truss system. Before use, the building designer must verify the applicability of the design parameters and properly incorporate this design into the overall building design. Bracing indicated is to prevent buckling of individual truss web and/or chord members only. Additional temporary and permanent bracing is always required for stability and to prevent collapse with possible personal injury and property damage. For general guidance regarding the fabrication, storage, delivery, erection and bracing of trusses and truss systems, see **ANSI/TP1 Quality Criteria and DSB-22** available from Truss Plate Institute (www.tpinst.org) and **BCSI Building Component Safety Information** available from the Structural Building Component Association (www.sbcsccomponents.com)

MiTek®

16023 Swingley Ridge Rd.
 Chesterfield, MO 63017
 314.434.1200 / MiTek-US.com

Job 3626267	Truss T18	Truss Type HIP	Qty 1	Ply 1	JT BLDRS - LOT 12 CCP	T31220152
----------------	--------------	-------------------	----------	----------	-----------------------	-----------

Builders FirstSource, Lake City, FL 32055

8.530 s May 26 2022 MiTek Industries, Inc. Fri Aug 4 10:50:56 2023 Page 1
ID:2eRY39KFhR2benj7cX?4RUzckGi-rEO_5m0JN1yyKbsqlXfBV0yJqhkoiNmXd03pyrPzT

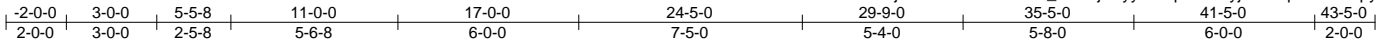

Scale = 1:76.4

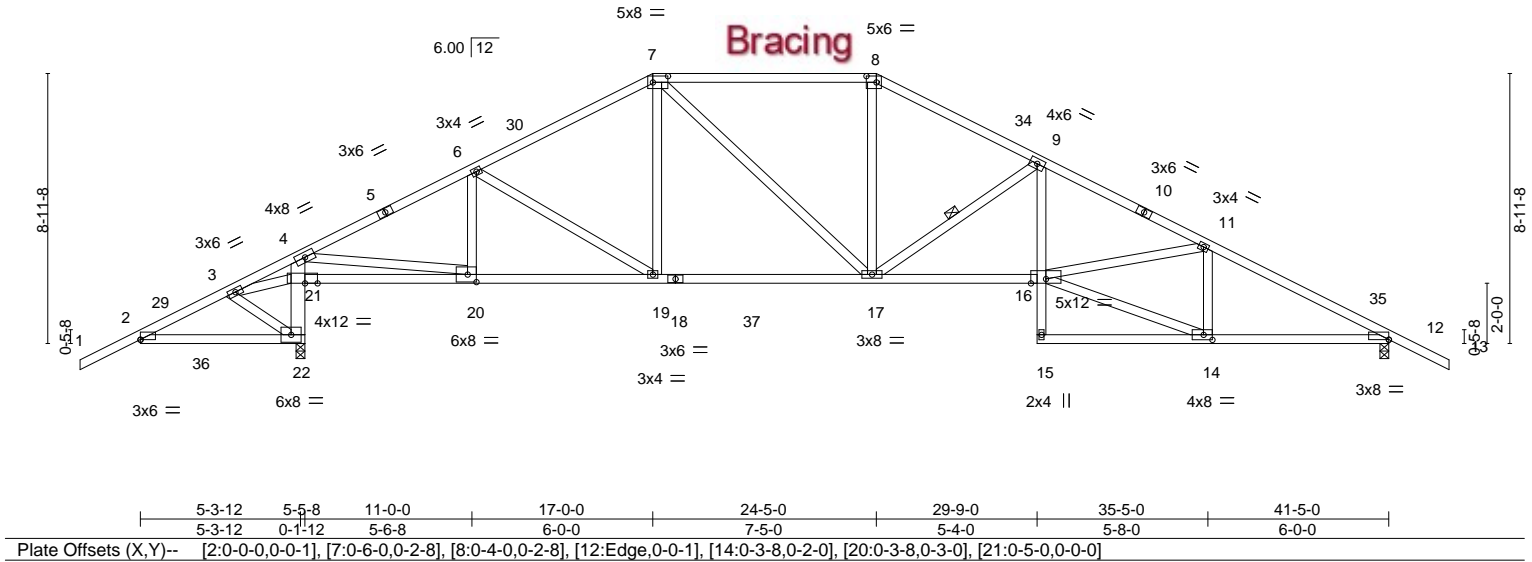

LOADING (psf)	SPACING-	CSL	DEFL.	PLATES	GRIP
TCLL 20.0	2-0-0	TC 0.97	in (loc) l/defl L/d	MT20	244/190
TCDL 7.0	Plate Grip DOL 1.25	BC 0.90	Vert(LL) -0.23 17-19 >999 240		
BCLL 0.0 *	Lumber DOL 1.25	WB 0.99	Vert(CT) -0.41 16-17 >999 180		
BCDL 10.0	Rep Stress Incr YES	Matrix-MS	Horz(CT) 0.10 12 n/a n/a		
	Code FBC2020/TP12014			Weight: 243 lb	FT = 20%

LUMBER-	BRACING-
TOP CHORD 2x4 SP No.2	TOP CHORD Structural wood sheathing directly applied.
BOT CHORD 2x4 SP No.2 *Except* 4-22: 2x6 SP No.2, 9-15: 2x4 SP No.3	BOT CHORD Rigid ceiling directly applied or 4-2-7 oc bracing.
WEBS 2x4 SP No.3 *Except* 4-20: 2x4 SP No.2	WEBS 1 Row at midpt 9-17

REACTIONS. (size) 12=0-3-8, 22=0-3-8
 Max Horz 22=137(LC 12)
 Max Uplift 12=-319(LC 13), 22=-397(LC 12)
 Max Grav 12=1492(LC 2), 22=2002(LC 2)

FORCES. (lb) - Max. Comp./Max. Ten. - All forces 250 (lb) or less except when shown.
 TOP CHORD 2-3=-495/551, 3-4=-1599/1708, 4-6=-1863/295, 6-7=-1873/315, 7-8=-1891/387,
 8-9=-2154/394, 9-11=-3259/573, 11-12=-2564/491
 BOT CHORD 2-22=-454/498, 21-22=-2068/786, 4-21=-2192/1043, 20-21=-1743/1901, 19-20=-227/1603,
 17-19=-143/1629, 16-17=-332/2886, 9-16=-115/947, 12-14=-348/2237
 WEBS 4-20=-1748/3282, 6-20=-319/278, 7-19=-11/332, 7-17=-152/428, 8-17=-54/660,
 9-17=-1228/314, 14-16=-365/2332, 11-16=-44/642, 11-14=-681/171, 3-22=-342/281,
 3-21=-1288/1335

- NOTES-**
- Unbalanced roof live loads have been considered for this design.
 - Wind: ASCE 7-16; Vult=130mph (3-second gust) Vasd=101mph; TCDL=4.2psf; BCDL=3.0psf; h=18ft; Cat. II; Exp B; Encl., GCpi=0.18; MWFRS (envelope) gable end zone and C-C Exterior(2E) -2-0-0 to 1-0-0, Interior(1) 1-0-0 to 17-0-0, Exterior(2R) 17-0-0 to 21-2-15, Interior(1) 21-2-15 to 24-5-0, Exterior(2R) 24-5-0 to 28-7-15, Interior(1) 28-7-15 to 43-5-0 zone; cantilever left exposed ;C-C for members and forces & MWFRS for reactions shown; Lumber DOL=1.60 plate grip DOL=1.60
 - Building Designer / Project engineer responsible for verifying applied roof live load shown covers rain loading requirements specific to the use of this truss component.
 - Provide adequate drainage to prevent water ponding.
 - This truss has been designed for a 10.0 psf bottom chord live load nonconcurrent with any other live loads.
 - * This truss has been designed for a live load of 20.0psf on the bottom chord in all areas where a rectangle 3-6-0 tall by 2-0-0 wide will fit between the bottom chord and any other members, with BCDL = 10.0psf.
 - Provide mechanical connection (by others) of truss to bearing plate capable of withstanding 100 lb uplift at joint(s) except (jt=lb) 12=319, 22=397.

This item has been electronically signed and sealed by O'Regan, Philip, PE using a Digital Signature. Printed copies of this document are not considered signed and sealed and the signature must be verified on any electronic copies.

Philip J. O'Regan PE No.58126
 MiTek Inc. DBA MiTek USA FL Cert 6634
 16023 Swingley Ridge Rd. Chesterfield, MO 63017
 Date:

August 4, 2023

<p>WARNING - Verify design parameters and READ NOTES ON THIS AND INCLUDED MITEK REFERENCE PAGE MII-7473 rev. 1/2/2023 BEFORE USE.</p> <p>Design valid for use only with MiTek® connectors. This design is based only upon parameters shown, and is for an individual building component, not a truss system. Before use, the building designer must verify the applicability of design parameters and properly incorporate this design into the overall building design. Bracing indicated is to prevent buckling of individual truss web and/or chord members only. Additional temporary and permanent bracing is always required for stability and to prevent collapse with possible personal injury and property damage. For general guidance regarding the fabrication, storage, delivery, erection and bracing of trusses and truss systems, see ANSI/TP1 Quality Criteria and DSB-22 available from Truss Plate Institute (www.tpinst.org) and BCSI Building Component Safety Information available from the Structural Building Component Association (www.sbcsccomponents.com)</p>	<p>16023 Swingley Ridge Rd. Chesterfield, MO 63017 314.434.1200 / MiTek-US.com</p>
---	--

Job 3626267	Truss T19	Truss Type PIGGYBACK BASE	Qty 1	Ply 1	JT BLDRS - LOT 12 CCP	T31220153
----------------	--------------	------------------------------	----------	----------	-----------------------	-----------

Builders FirstSource, Lake City, FL 32055

ID:2eRY39KFhR2benj7cX?4RUzckGi-JQyMJ61xUh9paUA2003ukiZ7Hp1jXIJW?BMZbFyrPzS
8.530 s May 26 2022 MiTek Industries, Inc. Fri Aug 4 10:50:57 2023 Page 1

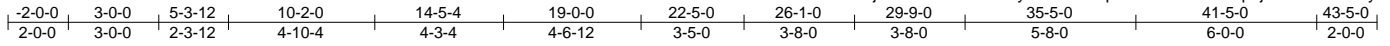

Scale = 1:76.4

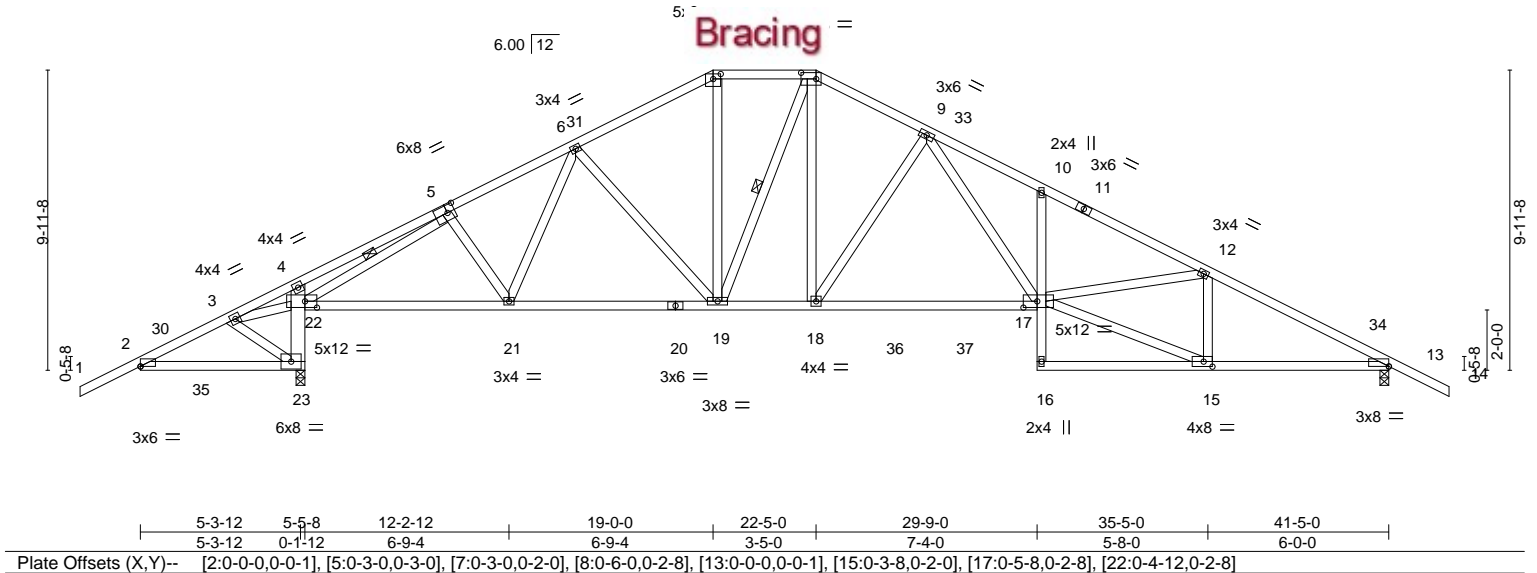

LOADING (psf)	SPACING-	CSL	DEFL.	PLATES	GRIP
TCLL 20.0	Plate Grip DOL 2-0-0	TC 0.98	in (loc) l/defl L/d	MT20	244/190
TCDL 7.0	Lumber DOL 1.25	BC 0.92	Vert(LL) -0.32 17-18 >999 240		
BCLL 0.0 *	Rep Stress Incr YES	WB 0.90	Vert(CT) -0.58 17-18 >751 180		
BCDL 10.0	Code FBC2020/TPI2014	Matrix-MS	Horz(CT) 0.09 13 n/a n/a		
				Weight: 264 lb	FT = 20%

LUMBER-	BRACING-
TOP CHORD 2x4 SP No.2	TOP CHORD Structural wood sheathing directly applied.
BOT CHORD 2x4 SP No.2 *Except*	BOT CHORD Rigid ceiling directly applied or 2-2-0 oc bracing.
4-23: 2x6 SP No.2, 10-16: 2x4 SP No.3	WEBS 1 Row at midpt 5-22, 8-19
WEBS 2x4 SP No.3	

REACTIONS.
(size) 13=0-3-8, 23=0-3-8
Max Horz 23=152(LC 12)
Max Uplift 13=-315(LC 13), 23=-393(LC 12)
Max Grav 13=1495(LC 2), 23=1988(LC 2)

FORCES.
(lb) - Max. Comp./Max. Ten. - All forces 250 (lb) or less except when shown.
TOP CHORD 2-3=-495/552, 3-4=-1576/1687, 4-5=-1862/1842, 5-6=-1835/326, 6-7=-1721/312, 7-8=-1503/306, 8-9=-1841/351, 9-10=-3188/621, 10-12=-3186/546, 12-13=-2573/485
BOT CHORD 2-23=-456/499, 22-23=-2066/794, 21-22=-235/1519, 19-21=-207/1630, 18-19=-93/1627, 17-18=-153/2073, 10-17=-255/150, 13-15=-342/2245
WEBS 3-23=-361/302, 3-22=-1283/1325, 5-22=-3545/1884, 5-21=-171/317, 6-19=-251/147, 7-19=-93/585, 8-19=-383/118, 8-18=-185/954, 9-18=-846/267, 9-17=-293/1357, 15-17=-356/2356, 12-17=-30/568, 12-15=-644/162

- NOTES-**
- Unbalanced roof live loads have been considered for this design.
 - Wind: ASCE 7-16; Vult=130mph (3-second gust) Vasd=101mph; TCDL=4.2psf; BCDL=3.0psf; h=18ft; Cat. II; Exp B; Encl., GCpi=0.18; MWFRS (envelope) gable end zone and C-C Exterior(2E) -2-0-0 to 1-0-0, Interior(1) 1-0-0 to 19-0-0, Exterior(2E) 19-0-0 to 22-5-0, Exterior(2R) 22-5-0 to 26-7-15, Interior(1) 26-7-15 to 43-5-0 zone; cantilever left exposed ;C-C for members and forces & MWFRS for reactions shown; Lumber DOL=1.60 plate grip DOL=1.60
 - Building Designer / Project engineer responsible for verifying applied roof live load shown covers rain loading requirements specific to the use of this truss component.
 - Provide adequate drainage to prevent water ponding.
 - This truss has been designed for a 10.0 psf bottom chord live load nonconcurrent with any other live loads.
 - * This truss has been designed for a live load of 20.0psf on the bottom chord in all areas where a rectangle 3-6-0 tall by 2-0-0 wide will fit between the bottom chord and any other members, with BCDL = 10.0psf.
 - Provide mechanical connection (by others) of truss to bearing plate capable of withstanding 100 lb uplift at joint(s) except (jt=lb) 13=315, 23=393.

This item has been electronically signed and sealed by O'Regan, Philip, PE using a Digital Signature. Printed copies of this document are not considered signed and sealed and the signature must be verified on any electronic copies.

Philip J. O'Regan PE No.58126
MiTek Inc. DBA MiTek USA FL Cert 6634
16023 Swingley Ridge Rd. Chesterfield, MO 63017
Date:

August 4, 2023

<p>WARNING - Verify design parameters and READ NOTES ON THIS AND INCLUDED MITEK REFERENCE PAGE MII-7473 rev. 1/2/2023 BEFORE USE.</p> <p>Design valid for use only with MiTek® connectors. This design is based only upon parameters shown, and is for an individual building component, not a truss system. Before use, the building designer must verify the applicability of design parameters and properly incorporate this design into the overall building design. Bracing indicated is to prevent buckling of individual truss web and/or chord members only. Additional temporary and permanent bracing is always required for stability and to prevent collapse with possible personal injury and property damage. For general guidance regarding the fabrication, storage, delivery, erection and bracing of trusses and truss systems, see ANSI/TPI1 Quality Criteria and DSB-22 available from Truss Plate Institute (www.tpinst.org) and BCSI Building Component Safety Information available from the Structural Building Component Association (www.sbcsccomponents.com)</p>	 <p>16023 Swingley Ridge Rd. Chesterfield, MO 63017 314.434.1200 / MiTek-US.com</p>
--	--

Job 3626267	Truss T20	Truss Type PIGGYBACK BASE	Qty 4	Ply 1	JT BLDRS - LOT 12 CCP	T31220154
----------------	--------------	------------------------------	----------	----------	-----------------------	-----------

Builders FirstSource, Lake City, FL 32055

ID:2eRY39KFhR2benj7cX?4RUzckGi-ncWlWS2ZF_HgBelEyja7Hw5J4DQrGlugEr678hrPzR
8.530 s May 26 2022 MiTek Industries, Inc. Fri Aug 4 10:50:58 2023 Page 1

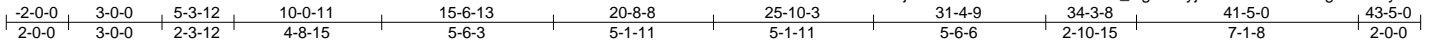

Scale = 1:74.0

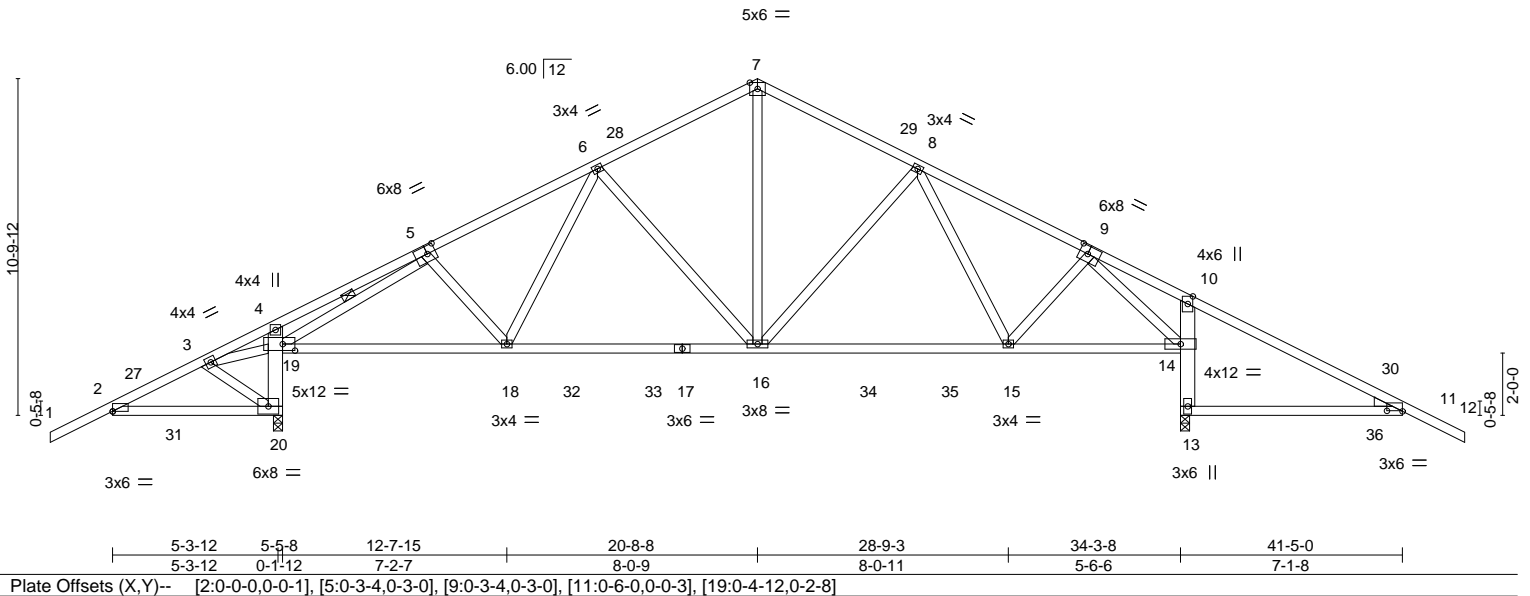

LOADING (psf)	SPACING-	2-0-0	CSI.	DEFL.	in (loc)	l/defl	L/d	PLATES	GRIP
TCLL 20.0	Plate Grip DOL	1.25	TC 0.92	Vert(LL)	-0.15 16-18	>999	240	MT20	244/190
TCDL 7.0	Lumber DOL	1.25	BC 0.73	Vert(CT)	-0.25 16-18	>999	180		
BCLL 0.0 *	Rep Stress Incr	YES	WB 0.94	Horz(CT)	-0.25 13	n/a	n/a		
BCDL 10.0	Code	FBC2020/TPI2014	Matrix-MS					Weight: 238 lb	FT = 20%

LUMBER-	BRACING-
TOP CHORD 2x4 SP No.2	TOP CHORD Structural wood sheathing directly applied or 2-2-0 oc purlins.
BOT CHORD 2x4 SP No.2 *Except 4-20: 2x6 SP No.2, 10-13: 2x6 SP M 26	BOT CHORD Rigid ceiling directly applied or 5-0-2 oc bracing.
WEBS 2x4 SP No.3	WEBS 1 Row at midpt 5-19
WEDGE Rigt: 2x4 SP No.3	

REACTIONS.	(size) 13=0-3-8, 20=0-3-8
	Max Horz 20=164(LC 12)
	Max Uplift 13=-385(LC 13), 20=-355(LC 12)
	Max Grav 13=1864(LC 2), 20=1663(LC 2)

FORCES.	(lb) - Max. Comp./Max. Ten. - All forces 250 (lb) or less except when shown.
TOP CHORD	2-3=-495/552, 3-4=-1579/1692, 4-5=-1902/1919, 5-6=-1307/263, 6-7=-978/223, 7-8=-978/239, 8-9=-883/164, 9-10=-1554/1734, 10-11=-615/787
BOT CHORD	2-20=-456/499, 19-20=-1741/697, 18-19=-204/1122, 16-18=-143/1137, 15-16=-38/917, 14-15=0/668, 13-14=-1740/606, 11-13=-610/621
WEBS	3-20=-361/302, 3-19=-1287/1328, 5-19=-3040/1753, 6-16=-365/191, 7-16=-119/630, 8-15=-374/344, 9-15=-325/684, 9-14=-2536/1256

- NOTES-**
- Unbalanced roof live loads have been considered for this design.
 - Wind: ASCE 7-16; Vult=130mph (3-second gust) Vasd=101mph; TCDL=4.2psf; BCDL=3.0psf; h=18ft; Cat. II; Exp B; Encl., GCp=0.18; MWFRS (envelope) gable end zone and C-C Exterior(2E) -2-0-0 to 1-0-0, Interior(1) 1-0-0 to 20-8-8, Exterior(2R) 20-8-8 to 24-11-7, Interior(1) 24-11-7 to 43-5-0 zone; cantilever left and right exposed ;C-C for members and forces & MWFRS for reactions shown; Lumber DOL=1.60 plate grip DOL=1.60
 - Building Designer / Project engineer responsible for verifying applied roof live load shown covers rain loading requirements specific to the use of this truss component.
 - This truss has been designed for a 10.0 psf bottom chord live load nonconcurrent with any other live loads.
 - * This truss has been designed for a live load of 20.0psf on the bottom chord in all areas where a rectangle 3-6-0 tall by 2-0-0 wide will fit between the bottom chord and any other members, with BCDL = 10.0psf.
 - Provide mechanical connection (by others) of truss to bearing plate capable of withstanding 100 lb uplift at joint(s) except (jt=lb) 13=385, 20=355.

This item has been electronically signed and sealed by O'Regan, Philip, PE using a Digital Signature. Printed copies of this document are not considered signed and sealed and the signature must be verified on any electronic copies.

Philip J. O'Regan PE No.58126
MiTek Inc. DBA MiTek USA FL Cert 6634
16023 Swingley Ridge Rd. Chesterfield, MO 63017
Date:

August 4, 2023

WARNING - Verify design parameters and READ NOTES ON THIS AND INCLUDED MITEK REFERENCE PAGE MII-7473 rev. 1/2/2023 BEFORE USE.

Design valid for use only with MiTek® connectors. This design is based only upon parameters shown, and is for an individual building component, not a truss system. Before use, the building designer must verify the applicability of design parameters and properly incorporate this design into the overall building design. Bracing indicated is to prevent buckling of individual truss web and/or chord members only. Additional temporary and permanent bracing is always required for stability and to prevent collapse with possible personal injury and property damage. For general guidance regarding the fabrication, storage, delivery, erection and bracing of trusses and truss systems, see **ANSI/TPI1 Quality Criteria and DSB-22** available from Truss Plate Institute (www.tpinst.org) and **BCSI Building Component Safety Information** available from the Structural Building Component Association (www.sbcsccomponents.com)

MiTek®

16023 Swingley Ridge Rd.
Chesterfield, MO 63017
314.434.1200 / MiTek-US.com

Job 3626267	Truss T21	Truss Type Roof Special	Qty 1	Ply 1	JT BLDRS - LOT 12 CCP	T31220155
----------------	--------------	----------------------------	----------	----------	-----------------------	-----------

Builders FirstSource, Lake City, FL 32055

ID:2eRY39KFhR2benj7cX?4RUzckGi-Fp47jo2C0IPXpnKQWR5Mp7eUKkki?CWpSVrgg8yrPzQ
8.530 s May 26 2022 MiTek Industries, Inc. Fri Aug 4 10:50:59 2023 Page 1

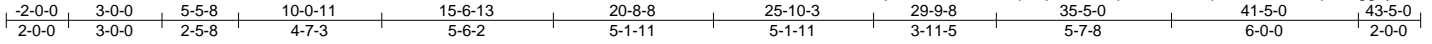

Scale = 1:74.0

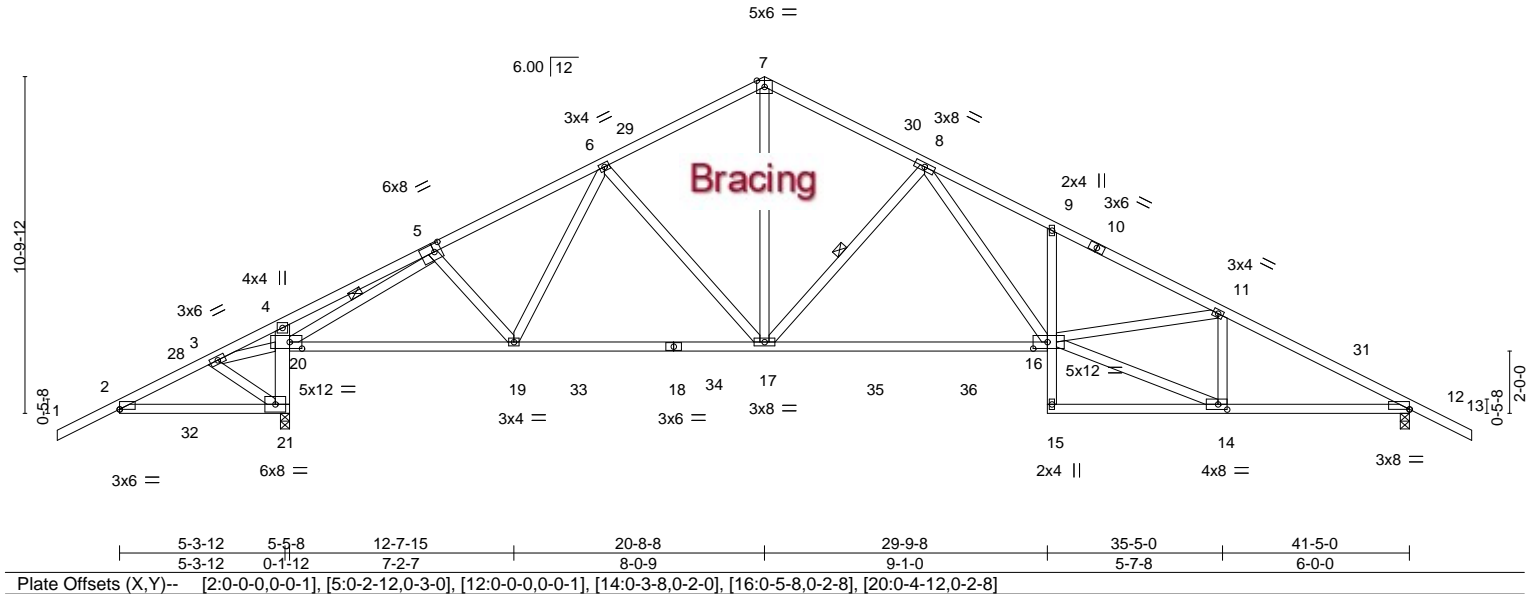

LOADING (psf)	SPACING-	CSL	DEFL.	PLATES	GRIP
TCLL 20.0	Plate Grip DOL 2-0-0	TC 0.95	in (loc) l/defl L/d	MT20	244/190
TCDL 7.0	Lumber DOL 1.25	BC 0.82	Vert(LL) -0.39 16-17 >999 240		
BCLL 0.0 *	Rep Stress Incr YES	WB 0.92	Vert(CT) -0.70 16-17 >619 180		
BCDL 10.0	Code FBC2020/TPI2014	Matrix-MS	Horz(CT) 0.10 12 n/a n/a		
				Weight: 247 lb	FT = 20%

LUMBER-	BRACING-
TOP CHORD 2x4 SP No.2	TOP CHORD Structural wood sheathing directly applied or 1-4-12 oc purlins.
BOT CHORD 2x4 SP No.2 *Except	BOT CHORD Rigid ceiling directly applied or 4-6-11 oc bracing.
4-21: 2x6 SP No.2, 9-15: 2x4 SP No.3, 16-18: 2x4 SP No.1	WEBS 1 Row at midpt 5-20, 8-17
WEBS 2x4 SP No.3	

REACTIONS. (size) 12=0-3-8, 21=0-3-8
 Max Horz 21=164(LC 12)
 Max Uplift 12=-312(LC 13), 21=-390(LC 12)
 Max Grav 12=1512(LC 2), 21=2020(LC 2)

FORCES. (lb) - Max. Comp./Max. Ten. - All forces 250 (lb) or less except when shown.

TOP CHORD 2-3=-507/552, 3-4=-1641/1688, 4-5=-1969/1890, 5-6=-1916/329, 6-7=-1716/323, 7-8=-1713/309, 8-9=-3263/608, 9-11=-3258/535, 11-12=-2608/477

BOT CHORD 2-21=456/509, 20-21=-2097/817, 19-20=-258/1612, 17-19=-204/1709, 16-17=-161/2080, 12-14=-336/2276

WEBS 3-21=-373/301, 3-20=-1283/1388, 5-20=-3621/1990, 5-19=-171/317, 6-17=-313/187, 7-17=-189/1278, 8-17=-910/299, 8-16=-283/1419, 14-16=-348/2406, 11-16=-34/614, 11-14=-652/160

- NOTES-** (7)
- 1) Unbalanced roof live loads have been considered for this design.
 - 2) Wind: ASCE 7-16; Vult=130mph (3-second gust) Vasd=101mph; TCDL=4.2psf; BCDL=3.0psf; h=18ft; Cat. II; Exp B; Encl., GCpi=0.18; MWFRS (envelope) gable end zone and C-C Exterior(2E) -2-0-0 to 2-1-11, Interior(1) 2-1-11 to 20-8-8, Exterior(2R) 20-8-8 to 24-10-3, Interior(1) 24-10-3 to 43-5-0 zone; cantilever left exposed ;C-C for members and forces & MWFRS for reactions shown; Lumber DOL=1.60 plate grip DOL=1.60
 - 3) Building Designer / Project engineer responsible for verifying applied roof live load shown covers rain loading requirements specific to the use of this truss component.
 - 4) This truss has been designed for a 10.0 psf bottom chord live load nonconcurrent with any other live loads.
 - 5) * This truss has been designed for a live load of 20.0psf on the bottom chord in all areas where a rectangle 3-6-0 tall by 2-0-0 wide will fit between the bottom chord and any other members, with BCDL = 10.0psf.
 - 6) Provide mechanical connection (by others) of truss to bearing plate capable of withstanding 100 lb uplift at joint(s) except (it=lb) 12=312, 21=390.
 - 7) This manufactured product is designed as an individual building component. The suitability and use of this component for any particular building is the responsibility of the building designer per ANSI TPI 1 as referenced by the building code.

This item has been electronically signed and sealed by O'Regan, Philip, PE using a Digital Signature. Printed copies of this document are not considered signed and sealed and the signature must be verified on any electronic copies.

Philip J. O'Regan PE No.58126
 MiTek Inc. DBA MiTek USA FL Cert 6634
 16023 Swingley Ridge Rd. Chesterfield, MO 63017
 Date:

August 4, 2023

WARNING - Verify design parameters and READ NOTES ON THIS AND INCLUDED MITEK REFERENCE PAGE MII-7473 rev. 1/2/2023 BEFORE USE.

Design valid for use only with MiTek® connectors. This design is based only upon parameters shown, and is for an individual building component, not a truss system. Before use, the building designer must verify the applicability of design parameters and properly incorporate this design into the overall building design. Bracing indicated is to prevent buckling of individual truss web and/or chord members only. Additional temporary and permanent bracing is always required for stability and to prevent collapse with possible personal injury and property damage. For general guidance regarding the fabrication, storage, delivery, erection and bracing of trusses and truss systems, see **ANSI/TPI1 Quality Criteria and DSB-22** available from Truss Plate Institute (www.tpinst.org) and **BCSI Building Component Safety Information** available from the Structural Building Component Association (www.sbcscomponents.com)

MiTek®
 16023 Swingley Ridge Rd.
 Chesterfield, MO 63017
 314.434.1200 / MiTek-US.com

Symbols

PLATE LOCATION AND ORIENTATION

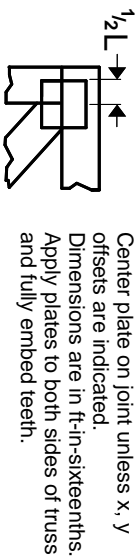

Center plate on joint unless x, y offsets are indicated. Dimensions are in ft-in-sixteenths. Apply plates to both sides of truss and fully embed teeth.

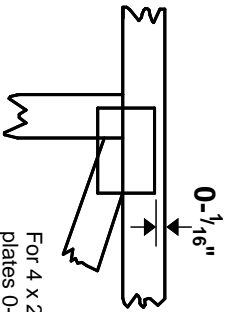

For 4 x 2 orientation, locate plates 0- 1/16\" from outside edge of truss.



This symbol indicates the required direction of slots in connector plates.

* Plate location details available in MITtek software or upon request.

PLATE SIZE

4 X 4

The first dimension is the plate width measured perpendicular to slots. Second dimension is the length parallel to slots.

LATERAL BRACING LOCATION



Indicated by symbol shown and/or by text in the bracing section of the output. Use T or I bracing if indicated.

BEARING



Indicates location where bearings (supports) occur. Icons vary but reaction section indicates joint number/letter where bearings occur. Min size shown is for crushing only.

Industry Standards:

ANSI/TFP1: National Design Specification for Metal Plate Connected Wood Truss Construction.
DSB-22: Design Standard for Bracing.
BCSI: Building Component Safety Information, Guide to Good Practice for Handling, Installing, Restraining & Bracing of Metal Plate Connected Wood Trusses.

Numbering System

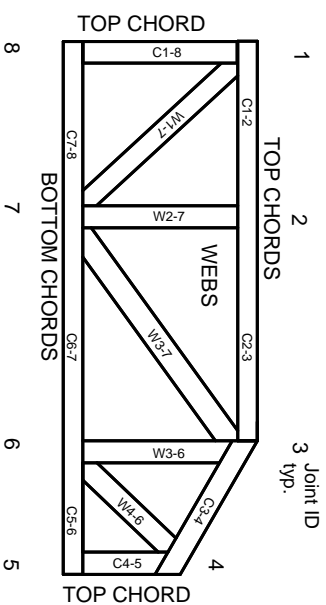

JOINTS ARE GENERALLY NUMBERED/LETTERED CLOCKWISE AROUND THE TRUSS STARTING AT THE JOINT FARTHEST TO THE LEFT.

CHORDS AND WEBS ARE IDENTIFIED BY END JOINT NUMBERS/LETTERS.

Product Code Approvals

ICC-ES Reports:

ESR-1-1988, ESR-2362, ESR-2685, ESR-3282
ESR-4722, ESL-1388

Design General Notes

Trusses are designed for wind loads in the plane of the truss unless otherwise shown.

Lumber design values are in accordance with ANSI/TFP 1 section 6.3. These truss designs rely on Lumber values established by others.

© 2023 MITtek® All Rights Reserved

General Safety Notes

Failure to Follow Could Cause Property Damage or Personal Injury

1. Additional stability/bracing for truss system, e.g. diagonal or X-bracing, is always required. See BCSI.
2. Truss bracing must be designed by an engineer. For wide truss spacing, individual lateral braces themselves may require bracing, or alternative Tor I bracing should be considered.
3. Never exceed the design loading shown and never stack materials on inadequately braced trusses.
4. Provide copies of this truss design to the building designer, erection supervisor, property owner and all other interested parties.
5. Cut members to bear tightly against each other.
6. Place plates on each face of truss at each joint and embed fully. Knots and wane at joint locations are regulated by ANSI/TFP 1.
7. Design assumes trusses will be suitably protected from the environment in accord with ANSI/TFP 1.
8. Unless otherwise noted, moisture content of lumber shall not exceed 19% at time of fabrication.
9. Unless expressly noted, this design is not applicable for use with fire retardant, preservative treated, or green lumber.
10. Camber is a non-structural consideration and is the responsibility of truss fabricator. General practice is to camber for dead load deflection.
11. Plate type, size, orientation and location dimensions indicated are minimum plating requirements.
12. Lumber used shall be of the species and size, and in all respects, equal to or better than that specified.
13. Top chords must be sheathed or purlins provided at spacing indicated on design.
14. Bottom chords require lateral bracing at 10 ft. spacing, or less, if no ceiling is installed, unless otherwise noted.
15. Connections not shown are the responsibility of others.
16. Do not cut or alter truss member or plate without prior approval of an engineer.
17. Install and load vertically unless indicated otherwise.
18. Use of green or treated lumber may pose unacceptable environmental, health or performance risks. Consult with project engineer before use.
19. Review all portions of this design (front, back, words and pictures) before use. Reviewing pictures alone is not sufficient.
20. Design assumes manufacture in accordance with ANSI/TFP 1 Quality Criteria.
21. The design does not take into account any dynamic or other loads other than those expressly stated.

MITek®

MITtek Engineering Reference Sheet: Mill-7473 rev. 1/2/2023