

KAREN ZETROUER

1262 SW BLUFF DR
FORT WHITE FL 32038

SOLAR CONTRACTOR:
SOLAR IMPACT, INC
4509 NW 23RD AVE., SUITE 20
GAINESVILLE, FL 32606
352.338.8221
WWW.SOLARIMPACT.COM

SOLAR CONTRACTOR LICENSE:
CVC56761
EC13012442

PROJECT MANAGER:
RAYMOND WALSH
386.603.1255
RAYMOND.WALSH@SOLARIMPACT.COM

PROJECT DESIGNER:
NICHOLAS WEBER
561.927.5136
NICHOLAS.WEBER@SOLARIMPACT.COM

ENGINEER OF RECORD:
BARRY M. JACOBSON
PE#51402
SOLAR IMPACT, INC
352.338.8221
BARRY@SOLARIMPACT.COM

CLIENT:
KAREN ZETROUER

GENERAL CONTRACTOR:
N/A

AUTHORITY HAVING JURISDICTION:
COLUMBIA COUNTY BUILDING DEPARTMENT

UTILITY:
CLAY ELECTRIC COOPERATIVE (CEC)

Designed By:



4509 NW 23rd Ave.
Suite.20
Gainesville, FL 32606
www.solarimpact.com
352.338.8221

DC:	16.49 KW-DC MODULE STC RATING
AC:	14.017 kW-AC GROSS POWER RATING
AC:	23 kW-AC INVERTER

PARTICIPANTS

THIS PROJECT CONSISTS OF AN EXPANSION TO AN EXISTING PHOTOVOLTAIC SYSTEM WITH THE ADDITION OF **4.85 KW-DC** TOTALING TO **16.49 KW-DC**. THE EXPANSION INCLUDES **TEN (10) SEG 485W MODULES (MODEL: SEG-485W-BTB-BG)** INSTALLED ON THE **NORTH-FACING ROOF SLOPE**, ORIENTED **DUE SOUTH AT A 10° TILT** FROM THE HORIZON AND **36°** FROM THE ROOF SURFACE. THE NEW ARRAY WILL BE MOUNTED USING A COMBINATION OF **UNISTRUT** AND **IRONRIDGE A2** RACKING COMPONENTS, SECURED TO THE EXISTING **STANDING-SEAM METAL ROOF** WITH **S-5-N** ATTACHMENT HARDWARE.

THE EXISTING PV SYSTEM WILL **REMAIN UNALTERED** ASIDE FROM THE ELECTRICAL INTEGRATION REQUIRED FOR THIS CAPACITY EXPANSION.

- G01: GENERAL NOTES
- A01: EQUIP. LOCATIONS
- A02: ELECTRICAL RISER
- A03: FIRE SAFETY
- E01: LINE DIAGRAM
- E02: PLACARDS
- E03: ELECTRICAL CALCS
- E04: MODULE DATA
- E05: RSD DATA
- E06: INVERTER DATA
- S01: ROOF ZONES
- S02: ROOF CALCS
- S03: ATTACHMENT DATA
- S04: RACKING DATA

- 2023 8th EDITION FLORIDA BUILDING CODE : BUILDING
- 2023 8th EDITION FLORIDA BUILDING CODE : RESIDENTIAL
- 2023 8th EDITION FLORIDA BUILDING CODE : MECHANICAL
- 2023 8th EDITION FLORIDA BUILDING CODE : PLUMBING
- 2023 8th EDITION FLORIDA BUILDING CODE : FUEL GAS
- 2023 8th EDITION FLORIDA BUILDING CODE : ENERGY CONSERVATION
- 2023 8th EDITION FLORIDA BUILDING CODE : EXISTING BUILDING
- 2023 8th EDITION FLORIDA BUILDING CODE : ACCESSIBILITY
- 2023 8th EDITION FLORIDA FIRE PREVENTION CODE (NFPA)
- 2020 NATIONAL ELECTRIC CODE (NEC)



REV#	DATE	REVISION NOTES
001	2/22/24	UPDATED CODE REFERENCES AND PW3
002	4/3/24	MOVED TILT ROW TO SOUTH EDGE OF ROOF PER CUSTOMER

Project Name:
KAREN ZETROUER

Project Address:
**1262 SW BLUFF DR
FORT WHITE FL 32038**

DOCUMENTS SIZED FOR 11"X17" PAPER

SYSTEM SUMMARY		EQUIPMENT SCHEDULE		
ITEM	DETAIL	LETTER	TYPE	DESCRIPTION
DC:	16.49 KW-DC MODULE STC RATING	A	UTILITY METER SOCKET	(E) 200A METER/MAIN 200A MAIN BREAKER 120/240V
AC:	14.017 KW-AC GROSS POWER RATING	B	TESLA GATEWAY	(E) TESLA ENERGY GATEWAY 2 YES 200A
AC:	23 KW-AC INVERTER	C	BACKUP PANEL	(E) LOADCENTER 200A 200A 120/240V
MODULES:	(E) 24 Q CELLS Q.PEAK DUO XL-G10.3 BFG/485 AND (N) 10 SEG SEG-485-BTB-BG	D	SOLAR DISCONNECT	(E) DISCONNECT 100A FUSIBLE 100A 120/240V SERVICE RATED NEMA3R (GENERIC)
	RSD: (N) 5 TESLA SSD (E) 12 TESLA SSD	E	INVERTER/BATTERY	(E) TESLA POWERWALL 3 60A TRUE
INVERTER(S):	(E) 2 TESLA POWERWALL 3	F	ROOF PENETRATION	(E) SOLADECK ROOF MOUNTED JUNCTION BOX
TILT FROM SURFACE:	0 AND 35°	G	RAPID SHUTDOWN DEVICE	(N) TESLA SSD
TILT FROM HORIZ:	24.9 AND 10.1°	H	MODULE	(E) Q CELLS Q.PEAK DUO XL-G10.3 BFG/485
AZIMUTH:	179°	I	MODULE	(N) SEG SEG-485-BTB-BG

Designed By:



4509 NW 23rd Ave.
Suite.20
Gainesville, FL 32606
www.solarimpact.com
352.338.8221

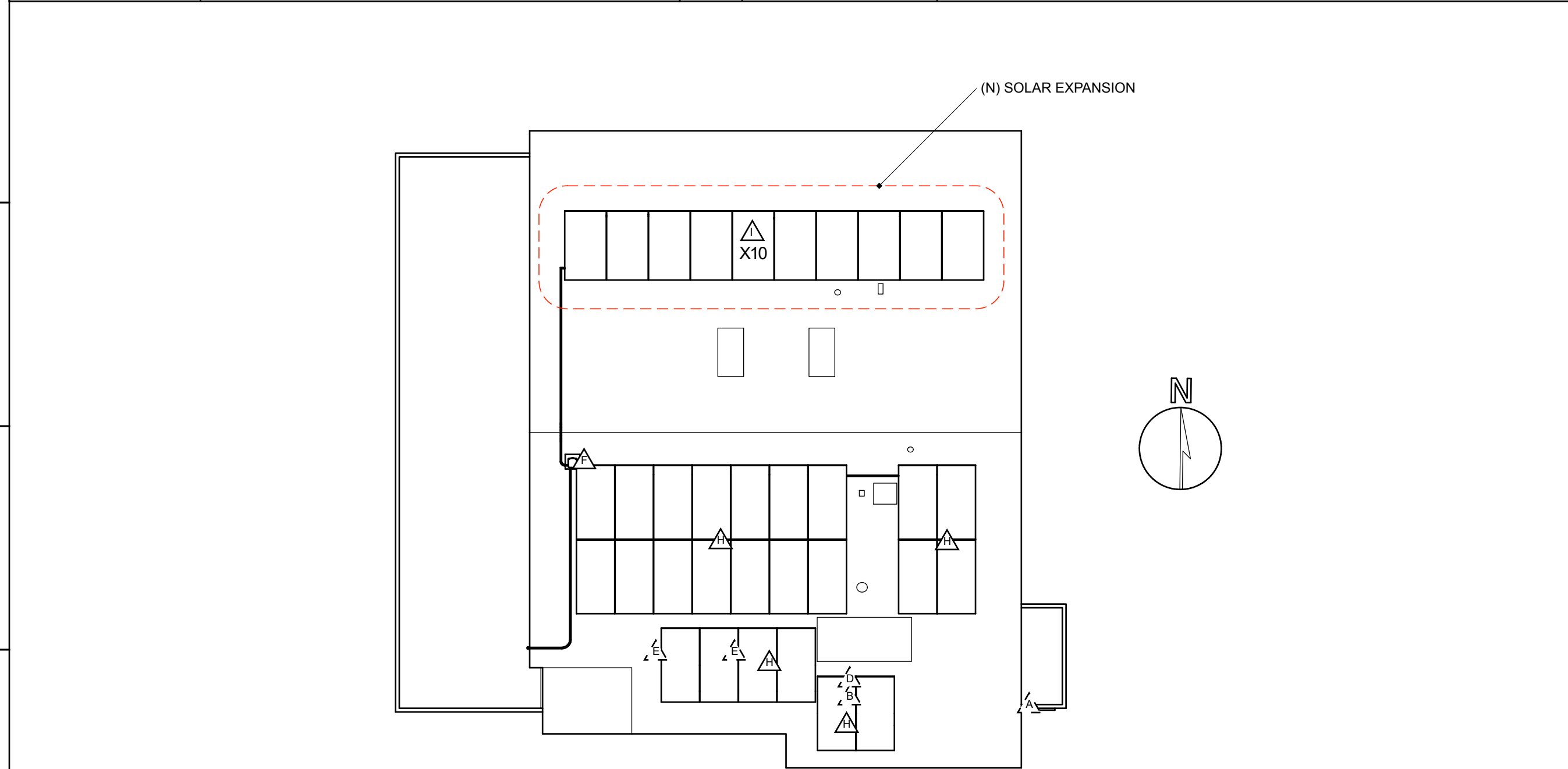

REV#	DATE	REVISION NOTES
001	2/22/24	UPDATED CODE REFERENCES AND PW3
002	4/3/24	MOVED TILT ROW TO SOUTH EDGE OF ROOF, PER CUSTOMER

Project Name:
KAREN ZETROUER

Project Address:
1262 SW BLUFF DR
FORT WHITE FL 32038

PAGE TITLE: EQUIPMENT LOCATIONS	PAGE #: A01
------------------------------------	-----------------------

EQUIPMENT SCHEDULE 

LETTER	TYPE	DESCRIPTION
A	UTILITY METER SOCKET	(E) 200A METER/MAIN 200A MAIN BREAKER 120/240V
B	TESLA GATEWAY	(E) TESLA ENERGY GATEWAY 2 YES 200A
C	BACKUP PANEL	(E) LOADCENTER 200A 200A 120/240V
D	SOLAR DISCONNECT	(E) DISCONNECT 100A FUSIBLE 100A 120/240V SERVICE RATED NEMA 3R (GENERIC)
E	INVERTER/BATTERY	(E) TESLA POWERWALL 3 60A TRUE
F	ROOF PENETRATION	(E) SOLADECK ROOF MOUNTED JUNCTION BOX
G	RAPID SHUTDOWN DEVICE	(N) TESLA SSD
H	MODULE	(E) Q CELLS Q.PEAK DUO XL-G10.3 BFG/485
I	MODULE	(N) SEG SEG-485-BTB-BG

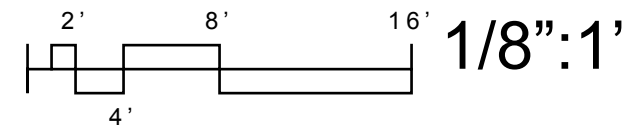

Designed By:



4509 NW 23rd Ave.
Suite 20
Gainesville, FL 32606
www.solarimpact.com
352.338.8221

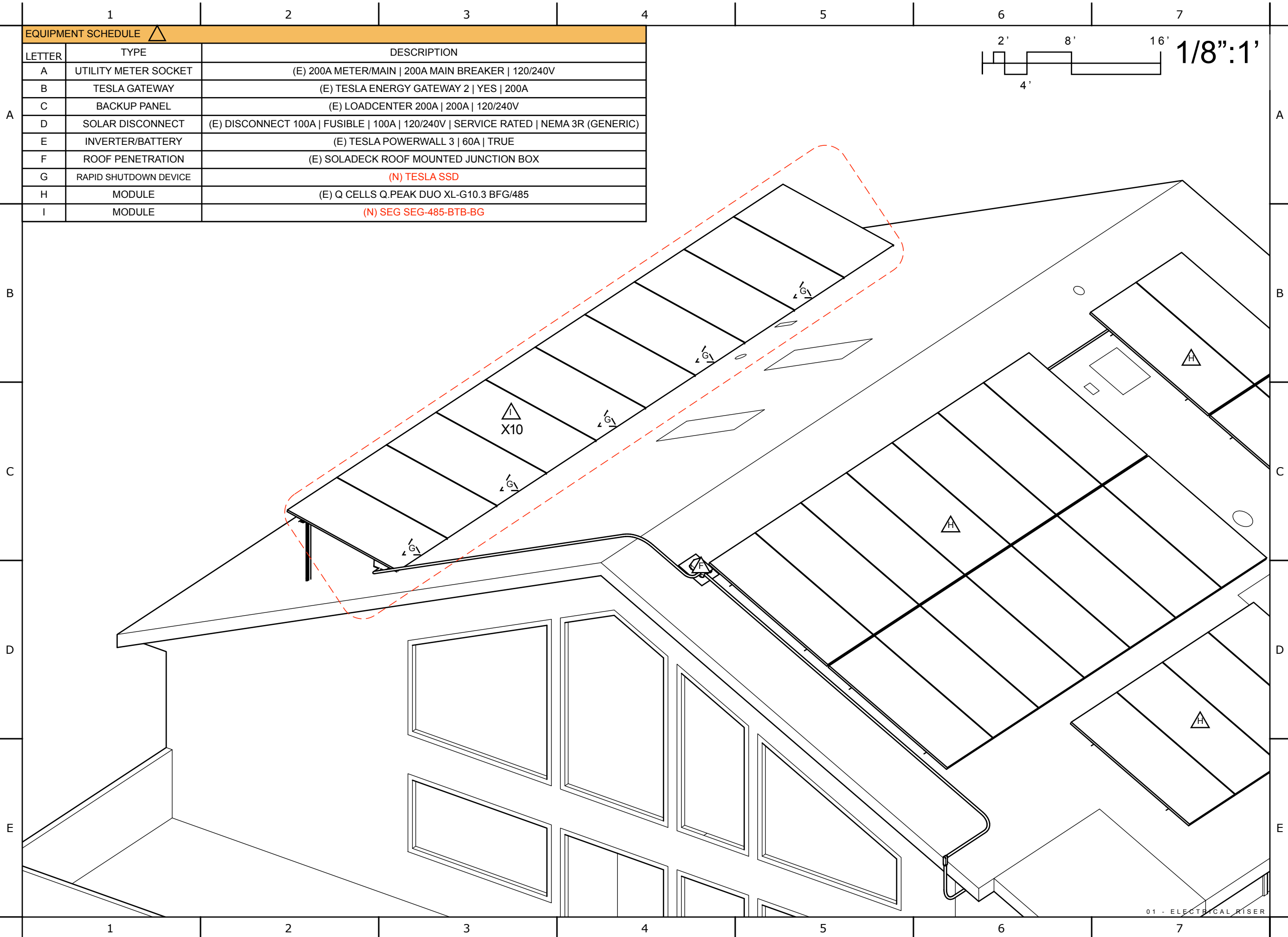

REV#	DATE	REVISION NOTES
001	2/22/24	UPDATED CODE REFERENCES AND PW3
002	4/3/24	MOVED TILT ROW TO SOUTH EDGE OF ROOF PER CUSTOMER

Project Name:
KAREN ZETROUER

Project Address:
1262 SW BLUFF DR
FORT WHITE FL 32038

PAGE TITLE: ELECTRICAL RISER

PAGE #: **A02**

01 - ELECTRICAL RISER

ROOF INFORMATION		
	QUANTITY	UNITS
ARRAY AREA	830	SF
ROOF AREA	2,564	SF
PERCENT COVERED	32%	-

LEGEND

WALKWAY 

2023 FBC - RESIDENTIAL, 8TH EDITION

R324.6.1 Pathways

Not fewer than two pathways, on separate roof planes from lowest roof edge to ridge and not less than **36 inches** (914 mm) wide, shall be provided on all buildings. Not fewer than one pathway shall be provided on the street or driveway side of the roof. For each roof plane with a photovoltaic array, a pathway not less than 36 inches wide (914 mm) shall be provided from the lowest roof edge to ridge on the same roof plane as the photovoltaic array, on an adjacent roof plane, or straddling the same and adjacent roof planes. Pathways shall be over areas capable of supporting fire fighters accessing the roof. Pathways shall be located in areas with minimal obstructions such as vent pipes, conduit or mechanical equipment.

R324.6.2 Setback at Ridge

For photovoltaic arrays occupying not more than **33 percent** of the plan view total roof area, not less than an **18-inch** (457 mm) clear setback is required on both sides of a horizontal ridge. For photovoltaic arrays occupying more than 33 percent of the plan view total roof area, not less than a 36-inch (914 mm) clear setback is required on both sides of a horizontal ridge.

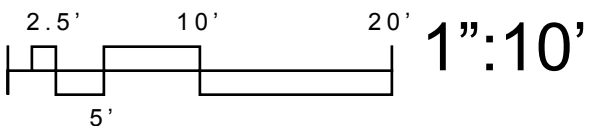
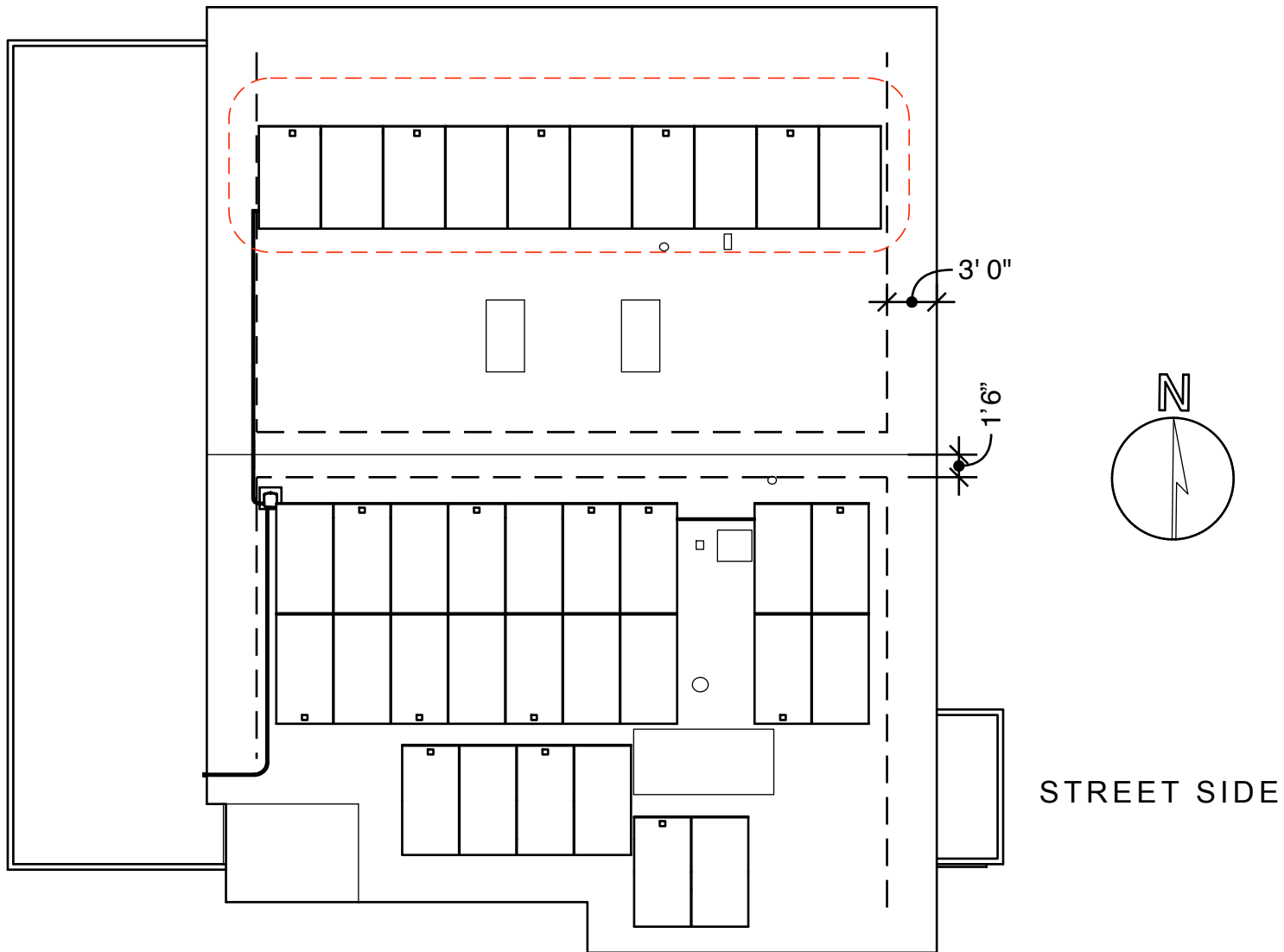

Designed By:



4509 NW 23rd Ave.
Suite.20
Gainesville, FL 32606
www.solarimpact.com
352.338.8221

REV#	DATE	REVISION NOTES
001	2/22/24	UPDATED CODE REFERENCES AND PW3
002	4/3/24	MOVED TILT ROW TO SOUTH EDGE OF ROOF PER CUSTOMER

Project Name:
KAREN ZETROUER

Project Address:
1262 SW BLUFF DR
FORT WHITE FL 32038

PAGE TITLE: FIRE SAFETY	PAGE # : A03
----------------------------	------------------------

EQUIPMENT SCHEDULE		
LETTER	TYPE	DESCRIPTION
A	UTILITY METER SOCKET	(E) 200A METER/MAIN 200A MAIN BREAKER 120/240V
B	TESLA GATEWAY	(E) TESLA ENERGY GATEWAY 2 YES 200A
C	BACKUP PANEL	(E) LOADCENTER 200A 200A 120/240V
D	SOLAR DISCONNECT	(E) DISCONNECT 100A FUSIBLE 100A 120/240V SERVICE RATED NEMA 3R (GENERIC)
E	INVERTER/BATTERY	(E) TESLA POWERWALL 3 60A TRUE
F	ROOF PENETRATION	(E) SOLADECK ROOF MOUNTED JUNCTION BOX
G	RAPID SHUTDOWN DEVICE	(N) TESLA SSD
H	MODULE	(E) Q CELLS Q.PEAK DUO XL-G10.3 BFG/485
I	MODULE	(N) SEG SEG-485-BTB-BG

CONDUCTOR SIZES	
A	(1 SET) 2X #3/0 CU + 1X #3/0 CU NTRL + 1X #6 CU GRD IN 2" PVC SCH 40/HPDE
B	(1 SET) 2X #1 CU + 1X #1 CU NTRL + 1X #6 CU GRD IN 1.5" PVC SCH 40/HPDE
C	(1 SET) 2X #3/0 CU + 1X #3/0 CU NTRL + 1X #6 CU GRD IN 2" PVC SCH 40/HPDE
D	(1 SET) 4X #6 CU + 2X #6 CU NTRL + 1X #10 CU GRD IN 1.25" EMT
E	(1 SET) 10X #10 CU + 2X #10 CU GRD IN 1" EMT
F	(5 SET) 2X #10 CU + 1X #4 CU GRD IN FREE AIR

FIELD APPLIED PLACARDS

1 SEE PLACARDS PAGE FOR DETAILS

*Note: NEC 705.95(B) says "Neutral Conductor for Instrumentation, Voltage Detection or Phase Detection. A conductor used solely for instrumentation, voltage detection, or phase detection and connected to a single-phase or 3-phase utility-interactive inverter, shall be permitted to be sized at less than the ampacity of the other current-carrying conductors and shall be sized equal to or larger than the equipment grounding conductor."

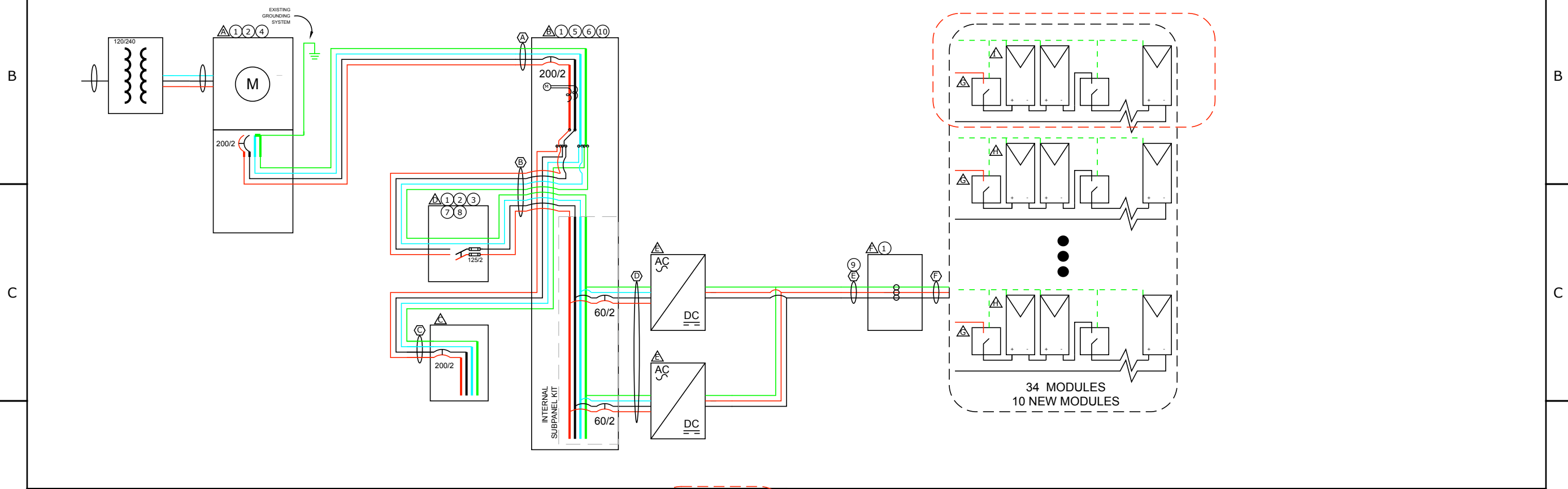

SOLAR SCHEDULE									
INVERTER	MODEL	MODULE	RSD	STRING # 1		STRING # 2		STRING # 3	
				MODULE	RSD	MODULE	RSD	MODULE	RSD
1	TESLA POWERWALL 3	Q Cells 485 W SEG 485 W	Tesla SSD	Q Cell 485 W 6	3	Q Cell 485 W 6	6	SEG 485 W 10	5
2	TESLA POWERWALL 3	Q Cells 485 W	Tesla SSD	Q Cell 485 W 6	3	Q Cell 485 W 6	6		

ADDITIONAL NOTES:

- EACH MODULE TO BE GROUNDED USING THE SUPPLIED CONNECTION POINT PER MANUFACTURER'S REQUIREMENTS. ALL SOLAR MODULES, EQUIPMENT, AND METALLIC COMPONENTS ARE TO BE BONDED. IF THE EXISTING GROUNDING ELECTRODE SYSTEM CAN NOT BE VERIFIED OR IS ONLY METALLIC WATER PIPING, IT IS THE CONTRACTOR'S RESPONSIBILITY TO INSTALL A SUPPLEMENTAL GROUNDING ELECTRODE.
- ALL PLAQUES AND SIGNAGE REQUIRED BY THE LATEST EDITION OF NATIONAL ELECTRICAL CODE. LABEL SHALL BE METALLIC OR PLASTIC, ENGRAVED OR MACHINE PRINTED IN A CONTRASTING COLOR TO THE PLAQUE. PLAQUE SHALL BE UV RESISTANT IF EXPOSED TO SUNLIGHT.
- DC CONDUCTORS SHALL BE RUN IN EMT AND SHALL BE LABELED, "CAUTION DC CIRCUIT" OR EQUIV. EVERY 5 FT.
- EXPOSED NON-CURRENT CARRYING METAL PARTS OF ELECTRICAL EQUIPMENT SHALL BE GROUNDED IN ACCORDANCE WITH 250.134 OR 250.136(A).
- CONFIRM LINE SIDE VOLTAGE AT ELECTRIC UTILITY SERVICE PRIOR TO CONNECTING INVERTER. VERIFY SERVICE VOLTAGE IS WITHIN INVERTER VOLTAGE OPERATIONAL RANGE.
- OUTDOOR EQUIPMENT SHALL BE NEMA-3R RATED OR BETTER.
- ELECTRICAL CONTRACTOR TO PROVIDE CONDUIT EXPANSION JOINTS AND ANCHOR CONDUIT RUNS AS REQUIRED PER NEC.
- ALL WIRING MUST BE PROPERLY SUPPORTED BY DEVICES OR MECHANICAL MEANS DESIGNED AND LISTED FOR SUCH USE, AND FOR ROOF-MOUNTED SYSTEMS, WIRING MUST BE PERMANENTLY AND COMPLETELY HELD OFF OF THE ROOF SURFACE. NEC 110.2 - 110.4 / 300.4
- TESLA INVERTERS AND POWERWALLS ARE PCS CONTROLLED TO NOT EXCEED THE LOAD CENTER'S BUS RAITING

ELECTRICAL NOTES

- ALL EQUIPMENT TO BE LISTED BY UL OR OTHER NRTL, AND LABELED FOR ITS APPLICATION.
- ALL CONDUCTORS SHALL BE COPPER, RATED FOR 600 V AND 90 DEGREE C WET ENVIRONMENT.
- WIRING, CONDUIT, AND RACEWAYS MOUNTED ON ROOFTOPS SHALL BE ROUTED DIRECTLY TO, AND LOCATED AS CLOSE AS POSSIBLE TO THE NEAREST RIDGE, HIP, OR VALLEY.
- WORKING CLEARANCES AROUND ALL NEW AND EXISTING ELECTRICAL EQUIPMENT SHALL COMPLY WITH NEC 110.26.
- DRAWINGS INDICATE THE GENERAL ARRANGEMENT OF SYSTEMS. CONTRACTOR SHALL FURNISH ALL NECESSARY OUTLETS, SUPPORTS, FITTINGS AND ACCESSORIES TO FULFILL APPLICABLE CODES AND STANDARDS.
- WHERE SIZES OF JUNCTION BOXES, RACEWAYS, AND CONDUITS ARE NOT SPECIFIED, THE CONTRACTOR SHALL SIZE THEM ACCORDINGLY.
- ALL WIRE TERMINATIONS SHALL BE APPROPRIATELY LABELED AND READILY VISIBLE.
- MODULE GROUNDING CLIPS TO BE INSTALLED BETWEEN MODULE FRAME AND MODULE SUPPORT RAIL, PER THE GROUNDING CLIP MANUFACTURER'S INSTRUCTION.
- MODULE SUPPORT RAIL TO BE BONDED TO CONTINUOUS COPPER G.E.C. VIA WEEB LUG OR ILSCO GBL-4DBT LAY-IN LUG.
- THE POLARITY OF THE GROUNDED CONDUCTORS IS NEGATIVE

REV#	DATE	REVISION NOTES
001	2/22/24	UPDATED CODE REFERENCES AND PW3
002	4/3/24	MOVED TILT ROW TO SOUTH EDGE OF ROOF PER CUSTOMER

Project Name: **KAREN ZETROUER**

Project Address: **1262 SW BLUFF DR FORT WHITE FL 32038**

PAGE TITLE: **LINE DIAGRAM**

PAGE #: **E01**

01 - LINE DIAGRAM

⚠ WARNING
ELECTRIC SHOCK HAZARD.
DO NOT TOUCH
TERMINALS. TERMINALS
ON BOTH THE LINE AND
LOAD SIDES MAY BE
ENERGIZED IN THE OPEN
POSITION

LOCATION: METER, MSD, BREAKER
PANEL, AC DISCONNECT, ROOF
MOUNTED JUNCTION BOX
REF: NEC 706.15 (C)(4) &
690.13(B)

X0

**WARNING: POWER
SOURCE OUTPUT
CONNECTION. DO
NOT RELOCATE THIS
OVERCURRENT
DEVICE**

LOCATION: PV BREAKER ON
LOADCENTER
REF: 705.12(B)(2)(c)

X0

CAUTION !

POWER TO THIS BUILDING IS ALSO SUPPLIED FROM
THE FOLLOWING SOURCES WITH DISCONNECTS
LOCATED AS SHOWN:

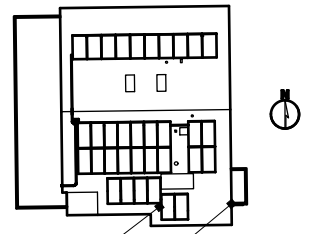

SOLAR DISCONNECT

MAIN SERVICE
DISCONNECT

1"=25"

LOCATION: SERVICE DISCONNECTS
REF: 690.10, 690.56(B)

X0

PHOTOVOLTAIC

AC DISCONNECT

LOCATION: PV AC DISCONNECT
REF: 690.13(B)
QTY: 1

X0

**PHOTOVOLTAIC AC
DISCONNECT**

RATED AC OUTPUT
CURRENT: **48.0AAC**
NOMINAL OPERATING AC
VOLTAGE: **240V**

X0

LOCATION: AC DISCONNECT
REF: 690.54

SOLAR PV DC CIRCUIT

x 6

LOCATION: DC CONDUIT EVERY 10' O.C.
REF: 690.31(G)(3)(4)

**PCS CONTROLLED
CURRENT SETTING** **200 A**

THE MAXIMUM OUTPUT CURRENT
FROM THIS SYSTEM TOWARDS
THE MAIN PANEL IS CONTROLLED
ELECTRONICALLY. REFER TO
MANUFACTURERS INSTRUCTIONS
FOR MORE INFORMATION.

X0

LOCATION: TESLA ENERGY
GATEWAY
REF: TESLA INSTALLATION
MANUAL

**SOLAR PV SYSTEM EQUIPPED
WITH RAPID SHUTDOWN**

TURN RAPID
SHUTDOWN SWITCH
TO THE "OFF"
POSITION TO
SHUTDOWN PV
SYSTEM AND
REDUCE SHOCK
HAZARD IN ARRAY

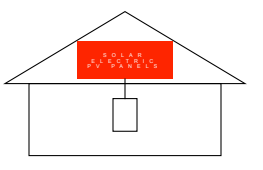

X0

LOCATION: AC & DC DISCONNECTS, POINT OF
INTERCONNECTION
REF: NEC 605.11.3.1(1) & 690.56(C)(1)(a)
QTY: 1

**⚠ WARNING: DUAL
POWER SOURCE
SECOND SOURCE IS
PHOTOVOLTAIC SYSTEM**

x 0

LOCATION: MAIN
SERVICE PANEL & NET
METER
REF: NEC 690.31(I)

**⚠ CAUTION
PHOTOVOLTAIC SYSTEM
CIRCUIT IS BACKFED**

x 0

LOCATION: MAIN SERVICE
PANEL
REF: NEC 690.13(F),
NEC 705.12(B)(3-4) &
NEC 690.59

⑩

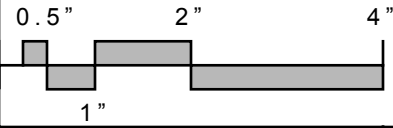

1/2":1"

REV#	DATE	REVISION NOTES
001	2/22/24	UPDATED CODE REFERENCES AND PW3
002	4/3/24	MOVED TILT ROW TO SOUTH EDGE OF ROOF PER CUSTOMER

Project Name:
**KAREN
ZETROUER**

Project Address:
**1262 SW BLUFF DR
FORT WHITE FL 32038**

PAGE TITLE: **PLACARDS**

PAGE #: **E02**

1	2	3	4	5	6	7		
LOCATION INFORMATION		CONDUCTOR, CONDUIT, & OCD SIZES 310.10(H)						
Location	Gainesville, FL	Conductor ID in Oneline	A	B	C	D	E	F
Temp, Ambient High (ASHRAE 2%)	34.0 C	Current-carrying Conductor	#3/0	#1	#3/0	#4	#10	#10
Temp, Ambient Low (ASHRAE Extreme)	-5.0 C	Insulation Type	THWN-2	THWN-2	THWN-2	THWN-2	THWN-2	PV Wire
Temp, Module Test	25.0 C	Side of Service	Load	Load	Load	Load	Load	Load
Temp, Delta Low	-30.0 C	Insulation Temp Rating	90 C	90 C	90 C	90 C	90 C	90 C
Temp, Below Ground	25.0 C	Conductor Material	CU	CU	CU	CU	CU	CU
MODULE SPECIFICATIONS AND CALCULATIONS		CURRENT SOURCE						
ITEM	MODULE 1	Current Type	AC	AC	AC	AC	DC	DC
Module Manufacturer	Q Cells	Current Source	Loads	Inverters	Loads	Inverter 1	Module 1	Module 1
Module Model	Q.Peak Duo XL-G10.3 BFG/485	Parallel Sources Combined	Not Combined	Not Combined	Not Combined	Not Combined	Not Combined	Not Combined
Module Power STC	485 W	# Parallel Sources	1	1	1	2	4	4
Module Operating Volt	45.63 VDC	# Sets of Conductors	1	1	1	2	4	4
Module Open-circuit Volt	53.63 VDC	# Conduits	1	1	1	1	1	4
Module Coeff Volt/Temp	-0.27 %/C	# Sets Conductors per OCD	1	1	1	1	1	1
Module Max Volt (Voc*(1+Td*VTCoeff))	57.97 VDC	# Conductors per Conduit	4	4	4	8	11	#N/A
Module Operating Current	10.63 A	# Current-Carrying Conductors per Conduit	2	2	2	4	10	2
Module Short-Circuit Current	11.16 A	# Grounds per Conduit	1	1	1	2	1	1
Module Max-Current (Isc*125%)	13.95 A	# Neutrals per Conduit	1	1	1	2	0	0
INVERTER SPECIFICATIONS AND CALCULATIONS		CONDITIONS OF USE CALCULATION 310.15 690.8(B)(2)(b)						
ITEM	INVERTER 1	Bottom of Conduit Distance Above Roof (or Below Ground)	#N/A	#N/A	#N/A	#N/A	4"	#N/A
Inverter Make	TESLA	Temperature Ambient High	34.0 C	34.0 C	34.0 C	34.0 C	34.0 C	34.0 C
Inverter Model	POWERWALL 3	Temperature Adjustment (roof/sun)	0.0 C	0.0 C	0.0 C	0.0 C	0.0 C	0.0 C
Inverter Qnty	1	Total Temperature	1.0 C	1.0 C	1.0 C	0.8 C	0.5 C	1.0 C
Inverter Power	11,500 W	Derate for Temp	96%	96%	96%	96%	96%	96%
Inverter Input Voltage, Max DC	600 VDC	Derate for Fill / Bundled	100%	100%	100%	80%	50%	100%
Inverter Input Voltage, Nominal DC	60-550	Conductor Ampacity, w/o derates	225.0 A	145.0 A	225.0 A	95.0 A	40.0 A	55.0 A
Inverter Output Voltage, AC	240 VAC	Min Ampacity required >= I _{max} conductor*125% 690.8(B)(1)	191.0 A	120.0 A	191.0 A	60.0 A	17.4 A	17.4 A
Inverter Input Current, Max DC	13.0 ADC	Conductor Ampacity, with derates and 240.4(D)	216.0 A	139.2 A	216.0 A	72.9 A	19.2 A	30.0 A
Inverter Output Current, AC	48.0 AAC	Min Ampacity required >= I _{max} conductor 690.8(B)(2)	191.0 A	96.0 A	191.0 A	48.0 A	13.9 A	13.9 A
Inverter Output Frequency	60 Hz	TERMINAL CALCULATION 110.14 310.15 690.8(B)(2)(a)						
Inverter Phase Qnty	1 Phase	Terminal Temp Rating	75 C	75 C	75 C	75 C	75 C	75 C
Inverter UL Listing	UL1741	Conductor Ampacity at terminals	200.0 A	130.0 A	200.0 A	85.0 A	30.0 A	50.0 A
Inverter Grounding	Ungrounded	Min Ampacity required >= I _{max} conductor*1.25 690.8(B)(1)	238.7 A	125.0 A	238.7 A	60.0 A	17.4 A	17.4 A
Max Modules in Series	#VALUE!	OVER-CURRENT 690.8, 690.9, 240.4B						
String Max Open Circuit Voltage	#VALUE!	# of Parallel Sources per OCD	1	1	1	1	1	1
		Min Ampacity required >= # parallel sources*I _{max} source x 1.25	191.0 A	120.0 A	191.0 A	60.0 A	17.4 A	17.4 A
		Over-current Device	200.0 A	125.0 A	200.0 A	60.0 A	#N/A	#N/A
		CONDUIT ANNEX C, CHAPTER 9 TABLE 1, 376.22						
		Conduit Type	PVC Sch 40/HPDE	PVC Sch 80	EMT	EMT	EMT	Free Air
		Nipple (less than or equal to 24-inches)	Not Nipple	Nipple	Not Nipple	Not Nipple	Not Nipple	Not Nipple
		Conduit diameter	2"	1.25"	2"	1.25"	1"	#N/A
		Max Allowable Conduit Fill	40%	60%	40%	40%	40%	#N/A
		Conduit Fill	26%	42%	25%	36%	27%	#N/A
		VOLTAGE DROP (WORST CASE), CHAPTER 9, TABLES 8 & 9						
		Conductor Length One-Way	25.3'	7.2'	111.1'	36.0'	46.6'	42.8'
		Power Factor	1	1	1	1	#N/A	#N/A
		Resistance	0.077 ohm/kft	0.15 ohm/kft	0.079 ohm/kft	0.31 ohm/kft	1.24 ohm/kft	1.24 ohm/kft
		Reactance	0.042 ohm/kft	0.046 ohm/kft	0.052 ohm/kft	0.06 ohm/kft	#N/A	#N/A
		Impedance	0.077 ohm/kft	0.15 ohm/kft	0.079 ohm/kft	0.31 ohm/kft	#N/A	#N/A
		Source Operating Current	191.0 A	96.0 A	191.0 A	48.0 A	10.6 A	10.6 A
		Conductor Operating Current,	191.0 A	96.0 A	191.0 A	48.0 A	10.6 A	10.6 A
		Nominal Operating Voltage	240.0 V	240.0 V	240.0 V	240.0 V	267.1 V	267.1 V
		Voltage Drop, total	0.74 V	0.20 V	3.27 V	1.69 V	1.23 V	1.13 V
		Voltage Drop, percentage	0.31%	0.08%	1.36%	0.70%	0.46%	0.42%

Designed By:



4509 NW 23rd Ave.
Suite.20
Gainesville, FL 32606
www.solarimpact.com
352.338.8221

REV#	DATE	REVISION NOTES
001	2/22/24	UPDATED CODE REFERENCES AND PW3
002	4/3/24	MOVED TILT ROW TO SOUTH EDGE OF ROOF PER CUSTOMER

Project Name: **KAREN ZETROUER**
Project Address: **1262 SW BLUFF DR FORT WHITE FL 32038**

PAGE TITLE: **ELECTRICAL CALCULATIONS** PAGE #: **E03**



www.segsolar.com



YUKON N Series SEG-XXX-BTB-BG-120Cells

Electrical Characteristics

Table with 4 columns: Module Type (SEG-470-BTB-BG, SEG-475-BTB-BG, SEG-480-BTB-BG, SEG-485-BTB-BG) and 3 rows of electrical parameters (Maximum Power, Open Circuit Voltage, Short Circuit Current, etc.)

STC: Irradiance 1000 W/m² module temperature 25°C AM=1.5 NOCT: Irradiance 800W/m² ambient temperature 20°C module temperature 45°C wind speed: 1m/s *Measuring tolerance: ±3%

Mechanical Specifications

Table with 2 columns: Specification (External Dimension, Weight, Solar Cells, etc.) and Value (1909 x 1134 x 30 mm, 27.3 kg, etc.)

*Refer to SEG installation manual for details

Temperature Characteristics

Table with 2 columns: Parameter (Pmax Temperature Coefficient, Voc Temperature Coefficient, etc.) and Value (-0.30 %/°C, -0.25 %/°C, etc.)

Packing Configuration

Table with 3 columns: Container (20'GP, 40'HQ, 40'HQ Per USA) and 2 rows of packing data (Pieces per Pallet, Pallets per Container, etc.)

I-V Curve

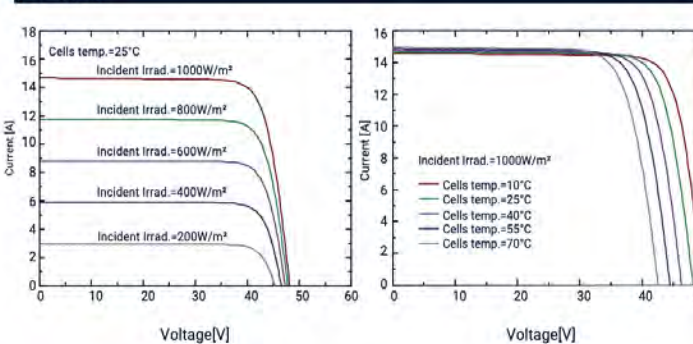

Technical Drawing

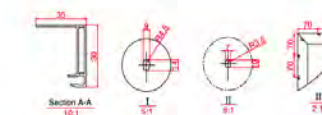
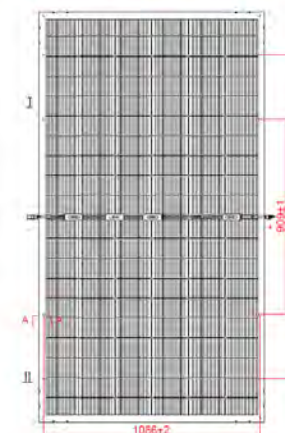
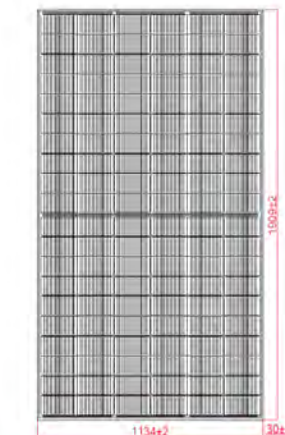

*Refer to SEG installation manual for details

www.segsolar.com

Specifications subject to technical changes SEG_DS_EN_2024V3.2 © Copyright 2024 SEG Solar

Designed By:



4509 NW 23rd Ave. Suite.20 Gainesville, FL 32606 www.solarimpact.com 352.338.8221

Table with 3 columns: REV#, DATE, REVISION NOTES. Includes revision 002 dated 4/3/24.

Project Name: KAREN ZETROUER Project Address: 1262 SW BLUFF DR FORT WHITE FL 32038

PAGE TITLE: MODULE DATA PAGE #: E04



YUKON N Series

Half-Cell N-Type Bifacial Module

470-485Wp | 22.40% Module Power Output | Max Efficiency

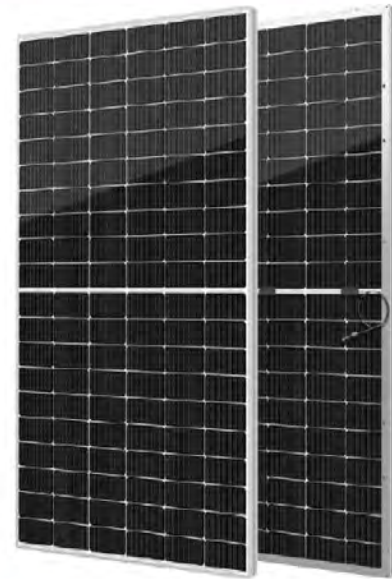

Key Features

- High module conversion efficiency, Better temperature coefficient, Super multi busbar technology, Low attenuation long warranty, Superior load capacity, Higher bifacially, USA based liability insurance, Houston, Texas based company

Warranty

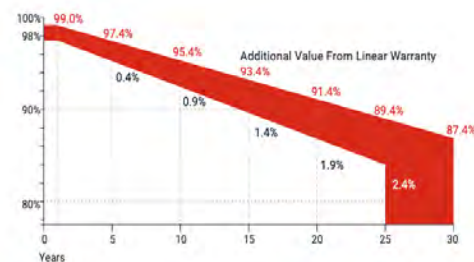

15 Years Guarantee on product material and workmanship, 30 Years Linear power output warranty

Product Certification

- IEC61215:2016; IEC 61730:2016; UL61215; UL61730, IEC62804, PID, IEC61701, Salt Mist, IEC62716, Ammonia Resistance, IEC60068, Dust and Sand, IEC61215, Hailstone, Fire Type (UL61730): Type 29, ISO14001:2015; ISO9001:2015; ISO45001:2018, FSC, PV CYCLE, CE, TÜV, DEKRA, CALIFORNIA ENERGY COMMISSION



Download Datasheet

About SEG Solar

Founded in 2016, SEG is a leading vertically integrated PV manufacturer headquartered in Houston, Texas, U.S., and is dedicated to delivering reliable and cost-effective solar modules to the utility, commercial and residential markets.

Designed By:



4509 NW 23rd Ave.
Suite 20
Gainesville, FL 32606
www.solarimpact.com
352.338.8221

SOLAR SHUTDOWN DEVICE

The Tesla Solar Shutdown Device is part of the PV system rapid shutdown (RSD) function in accordance with Article 690 of the applicable NEC. When paired with Powerwall+, solar array shutdown is initiated by turning the Powerwall+ Enable switch off, or by pushing the System Shutdown Switch if one is present.



ELECTRICAL SPECIFICATIONS

Nominal Input DC Current Rating (I_{mp})	12 A
Maximum Input Short Circuit Current (I_{sc})	15 A
Maximum System Voltage	600 V DC

MECHANICAL SPECIFICATIONS

Electrical Connections	MC4 Connector
Housing	Plastic
Dimensions	125 mm x 150 mm x 22 mm (5 in x 6 in x 1 in)
Weight	350 g (0.77 lb)
Mounting Options	ZEP Home Run Clip M4 Screw (#10) M8 Bolt (5/16") Nail / Wood screw

RSD MODULE PERFORMANCE

Maximum Number of Devices per String	5
Control	Power Line Excitation
Passive State	Normally open
Maximum Power Consumption	7 W
Warranty	25 years

COMPLIANCE INFORMATION

Certifications	UL 1741 PVRSE, UL 3741, PVRSA (Photovoltaic Rapid Shutdown Array)
RSD Initiation Method	External System Shutdown Switch
Compatible Equipment	See <i>Compatibility Table</i> below

ENVIRONMENTAL SPECIFICATIONS

Ambient Temperature	-40°C to 50°C (-40°F to 122°F)
Storage Temperature	-30°C to 70°C (-22°F to 158°F)
Enclosure Rating	NEMA 4 / IP65

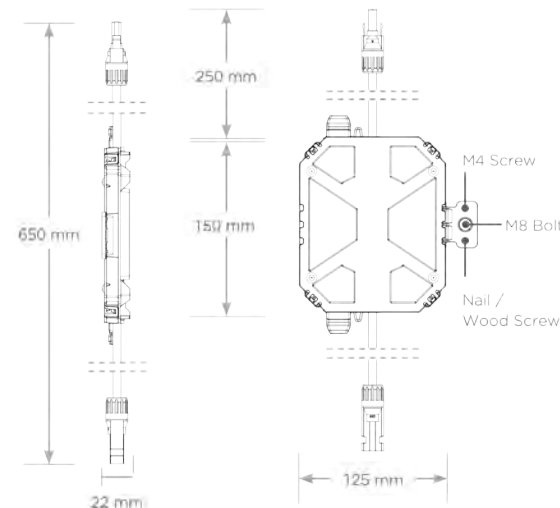

UL 3741 PV HAZARD CONTROL (AND PVRSA) COMPATIBILITY

Tesla Solar Roof and Tesla/Zep ZS Arrays using the following modules are certified to UL 3741 and UL 1741 PVRSA when installed with the Powerwall+ and Solar Shutdown Devices. See the Powerwall+ Installation Manual for detailed instructions and for guidance on installing Powerwall+ and Solar Shutdown Devices with other modules.

Brand	Model	Required Solar Shutdown Devices
Tesla	Solar Roof V3	1 Solar Shutdown Device per 10 modules
Tesla	Tesla TxxxS (where xxx = 405 to 450 W, increments of 5)	1 Solar Shutdown Device per 3 modules ¹
Hanwha	Q.PEAK DUO BLK-G5	1 Solar Shutdown Device per 3 modules
Hanwha	Q.PEAK DUO BLK-G6+	1 Solar Shutdown Device per 3 modules

Exception. Tesla solar modules installed in locations where the max Voc for three modules at low design temperatures exceeds 165 V shall be limited to two modules between MCIs.

T E S L A

NA 2021-09-08

TESLA.COM/ENERGY

REV#	DATE	REVISION NOTES
001	2/22/24	UPDATED CODE REFERENCES AND PW3
002	4/3/24	MOVED TILT ROW TO SOUTH EDGE OF ROOF PER CUSTOMER

Project Name:
KAREN ZETROUER

Project Address:
**1262 SW BLUFF DR
FORT WHITE FL 32038**

PAGE TITLE: TESLA RSD / GATEWAY
PAGE #: **E05**

The building has a gulflok roof. The roof support is hidden fastener roof with 26 ga steel on 24-inch centers. The section of the roof where the PV will be installed is Gabled with a roof slope of 5.58:12 slope. ASCE 7-22 with adjustment for rooftop solar modules parallel to the roof surface (29.4.4) was used for the roof section with solar. The design wind speed is 130 mph.

The solar modules and racking will add approximately 3 psf to the roof. This roof has been evaluated and deemed sufficient to support this added load.

Roof section with 5.58:12 slope and flush mounted non-exposed solar modules with A2 rails

Roof Zone	Max Force	Attachment Spacing	Nominal Attachment Spacing	Max Cantilever	# Rails per Module	Module Area per Attachment	Uplift
1	-17.40 psf	72 in	72 in	29 in	2	21.8 ft2	379.5 lbs
2	-26.85 psf	47 in	24 in	19 in	2	14.3 ft2	386.0 lbs
3	-32.01 psf	40 in	24 in	16 in	2	12.0 ft2	386.0 lbs

For angled solar panels, install legs using Unistrut P1000 or equivalent aluminum channel (1 5/8" x 1 5/8" C-channel). Channel can be solid or perforated. Legs are installed at the same spacing as detailed above for other roof attachments. Cross-brace legs using Unistrut P1000, IronRide XR10, Unirac SolarMount, rails or equivalent. Cross-bracing must be installed at both ends of the row and at least every fifth leg. Support legs must be installed at an angle between vertical to the ground and perpendicular to the solar modules (see Figure 3).

Roof Zone	Max Force	Attachment Spacing	Nominal Attachment Spacing	Max Cantilever	# Rails per Module	Module Area per Attachment	Uplift
1	-11.60 psf	72 in	72 in	29 in	2	21.8 ft2	253.0 lbs
2	-17.90 psf	71 in	48 in	28 in	2	21.5 ft2	386.0 lbs
3	-21.34 psf	60 in	48 in	24 in	2	18.0 ft2	385.0 lbs

Roof zone #1 is the interior area of the roof that is not within the other zones. Roof zone #2 is the area that is not within zone #3 and is within 4 ft 2 in of the roof ridges and rakes. Roof zone #3 is a 4 ft 2 in x 4 ft 2 in square at the upper corners of the roof.

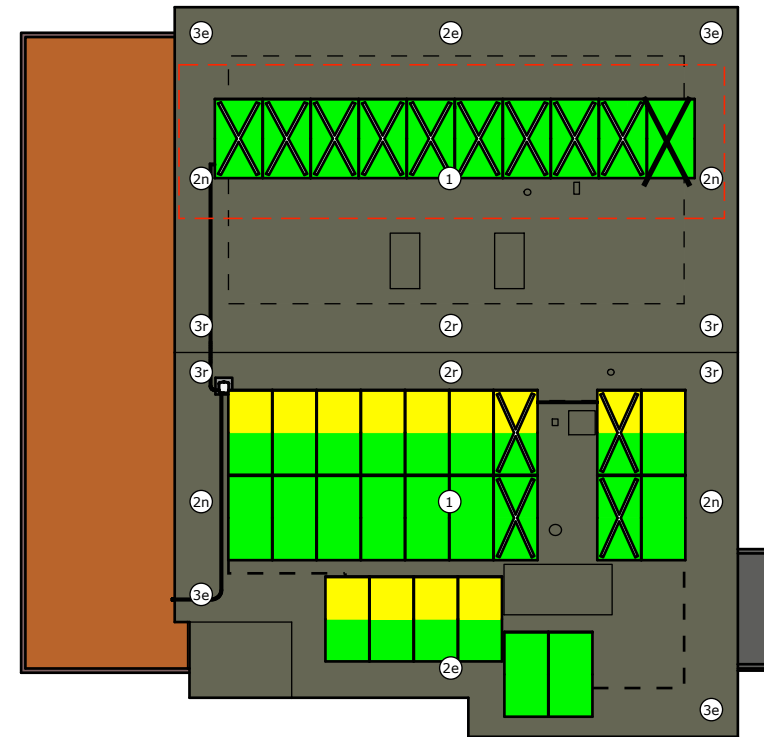

a = 4 ft 2 in X - EXPOSED MODULES

Installation Requirements

Expansion Joint Nut

Designed By:



4509 NW 23rd Ave.
Suite 20
Gainesville, FL 32606
www.solarimpact.com
352.338.8221

REV#	DATE	REVISION NOTES
001	2/22/24	UPDATED CODE REFERENCES AND PW3
002	4/3/24	MOVED TILT ROW TO SOUTH EDGE OF ROOF PER CUSTOMER

Project Name:
KAREN ZETROUER

Project Address:
1262 SW BLUFF DR
FORT WHITE FL 32038

PAGE TITLE: ROOF ZONES
PAGE #: S01

1	2	3	4	5	6	7		
IronRidge socket and torque settings		Fastener Qty	FastenQty	two				
		Eave Height	Eht	19.084248 ft				
		Building Width Perpendicular to Ridge	W	41.8 ft				
		Building Length Parallel to Ridge	L	49.0 ft				
Wind Speed	V	130 mph	Soffit Width	OH	24 in			
Roof Type	RoofType	Gabled	Slope of Roof	Slope	5.58:12			
Roof Material	RoofMat	GulfLok	Exposure Category	EC	B			
Attachment	Attach	S-5N	Module Model	ModModel	Q.Peak Duo XL-G10.3 BFG/485			
Substrate	Substrate	hidden fastener roof	Min Attachment Spacing	MinAS	24 in			
Substrate Material	SubstrateMat	26 ga steel	Max Attachment Spacing	MaxAS	72 in			
External Pressure Coefficients, (GC), for Enclosed and Partially Enclosed Buildings (Figure 30.3-2B to 30.3-2H and 29.4-7)		Module Orientation	Orient	Portrait				
		Low Module Height Above Roof	H1	3.5 in				
		Module Tilt from Roof	omega	34				
		Parapet Height	hpt	0 ft				
		Rail Type	railType	IronRidge				
Roof Zone	GCp min		Rail Selection	rail	A2			
1	-1.286		Safety Factor	SafetyFactor	2			
2	-1.985		Design Attachment Uplift	AttachUp	386 lbs			
3	-2.366		Module Length	Lp	87.2 in			
<p>For angled solar panels (see Figure 3), install legs using Unistrut P1000 or equivalent aluminum channel (1 5/8" x 1 5/8" C-channel). Channel can be solid or perforated. Legs are installed at the same spacing as detailed above for other roof attachments. Cross-brace legs using Unistrut P1000 or Unirac SolarMount rails or equivalent. Cross-bracing must be installed at both ends of the row and at least every fifth leg. Support legs must be installed at an angle between vertical to the ground and perpendicular to the solar modules.</p> <p>Figure 3 - Angled Bracing</p>			Module Width	Wp	41.1			
				Cell Count	CellCount	78		
				Min Strike Zone Distance	StrikeMin	11.8 in		
				Max Strike Zone Distance	StrikeMax	21.6 in		
				Roof Angle	Theta	24.9		
				Roof Slope Category	lowSlope	FALSE		
				Ridge Height	RHt	29.7 ft		
				Roof Height Reference	RoofHtRef	mean roof height above grade		
				Roof Height	h	24.4 ft		
				Half Roof Height	rh2	12.2 ft	Figure 29.4-8	
				Area of Solar Module	Asm	24.88 ft2	Figure 29.4-8	
				Solar Module Pressure Equalization Factor	Ga	0.626		
				Width for Zone 2 and 3 Determination	a	4.18 ft	$a = \max(3, 0.04 \cdot h, \min(0.4 \cdot h, 0.1 \cdot W, 0.1 \cdot L))$	
				Least Building Horiz Dist	B	41.87 ft	$B = \min(W, L)$	
				Mean Roof Height : Least Building Horiz Dist	h/B	0.58		
		Load Factor Based on Strength Design	LF	0.6	Load factor for FL Building Code and ASD = 0.6. 3.1.5 The weight of solar panels, their support system, and ballast shall be considered as dead load.			
		Topographic Factor	Kzt	1	Topographic Factor is 1 since no topographic feature specified			
		Wind Directionality Factor	Kd	0.85	Table 26.6-1 kd=0.85 for buildings			
		Ground Elevation Factor	Ke	1	Table 26.9-1. Value of 1.0 is permissible for all elevations			
		Velocity Pressure Exposure Coefficient	Kh	0.652	Table 26.10-1 if $h < 15$ then $Kh = 2.51 \cdot (15/zg)^{(2/\alpha)}$ else if $h \leq zg$ then $Kh = 2.51 \cdot (h/zg)^{(2/\alpha)}$			
		Velocity Pressure at Mean Roof Height	qh	16.9 psf	26.10.2 $qh = 0.00256 \cdot Kh \cdot Kzt \cdot Kd \cdot Ke \cdot V^2 \cdot LF$			
		Exposure Category Coefficient alpha	alpha	7.5	Table 26.11-1			
		Exposure Category Coefficient zg	zg	3,280 ft	Table 26.11-1			
		Parapet Height Factor	Gp	0.9 psf	Eqn 29.4-6 $Gp = \min(1.2, 0.9 + hpt/h)$			
		Panel Cord Factor	Gc	1.03	Eqn 29.4-6 $Gc = \max(0.6 + 0.06 \cdot Lp/12, 0.8)$			
		Normalized wind area	An	110.61	Figure 29.4-7 $An = 1000 / \max(Lb, 15)^2 \cdot Asm$			
		Normalized Building Length	Lb	14.52	Figure 29.4-7 $Lb = \min(0.4 \cdot (h \cdot \max(Wl, Ws))^{0.5}, h, B)$			
		High Module Height Above Roof	H2	40.00 in				
		Limit for Adjacent Modules	d1_limit	13.33 ft	$d1_limit = \max(4 \cdot h2, 4 \text{ ft})$			
		Min Horiz Dist Between Modules & Roof Edge	d_minHoriz	6.66 ft	$d_minHoriz = 2 \cdot h2$			

Designed By:



4509 NW 23rd Ave.
Suite.20
Gainesville, FL 32606
www.solarimpact.com
352.338.8221

REV#	DATE	REVISION NOTES
001	2/22/24	UPDATED CODE REFERENCES AND PW3
002	4/3/24	MOVED TILT ROW TO SOUTH EDGE OF ROOF
		PER CUSTOMER

Project Name: **KAREN ZETROUER**

Project Address: **1262 SW BLUFF DR
FORT WHITE FL 32038**

PAGE TITLE: **ROOF ZONE CALCS**

PAGE #: **S02**



CLIENT NAME	IRONRIDGE
PROJECT NAME	SLOPED ROOF MOUNT SYSTEM
PROJECT ADDRESS	
SYSTEM KW DC	

WIND SPEED, MPH	
SNOW LOAD, PSF	
EXPOSURE CAT	
RISK CAT	
MODULE TYPE	72-CELL, GENERIC
MODULE W/DC	
MODULE QTY	

NOT FOR CONSTRUCTION

REV	DESCRIPTION	DATE

SHEET NAME:
SLOPED ROOF PV SYSTEM DETAILS: S-5-U ASSEMBLY

3.1 SR
DEC 2018
IR 9.4
24X36

REV#	DATE	REVISION NOTES
001	2/22/24	UPDATED CODE REFERENCES AND PW3
002	4/3/24	MOVED TILT ROW TO SOUTH EDGE OF ROOF PER CUSTOMER

Project Name:
KAREN ZETROUER

Project Address:
1262 SW BLUFF DR
FORT WHITE FL 32038

PAGE TITLE: ATTACHMENT DATA
PAGE #: S03

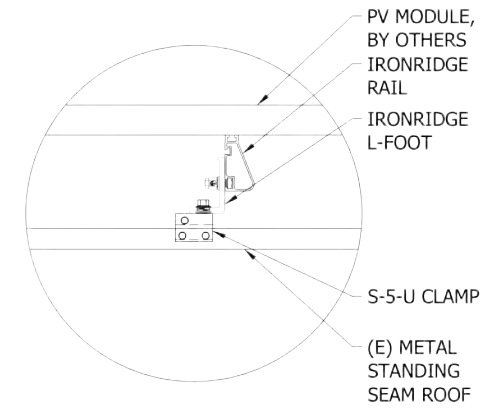

H STANDOFF DETAIL
Scale: 3"=1'-0"

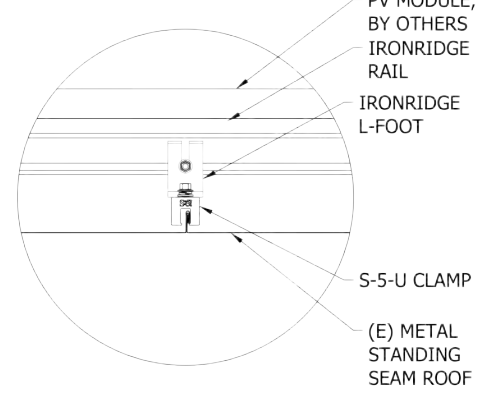

J STANDOFF DETAIL
Scale: 3"=1'-0"

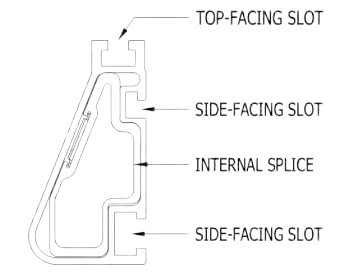

M DETAIL, SPLICE, XR1000
1'-0"=1'-0"

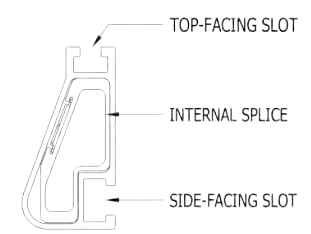

N DETAIL, SPLICE, XR100
1'-0"=1'-0"

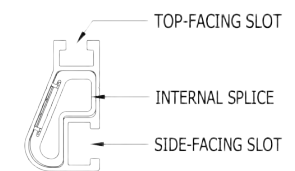

O DETAIL, SPLICE, XR10
1'-0"=1'-0"

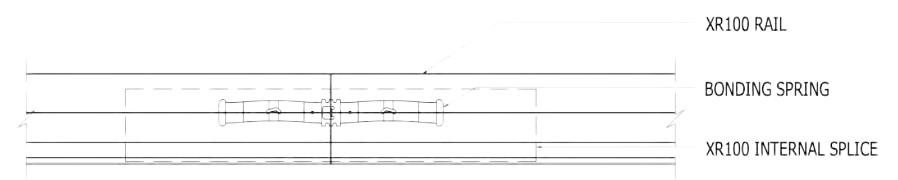

K DETAIL, SPLICE CONNECTION, XR100
6"=1'-0"

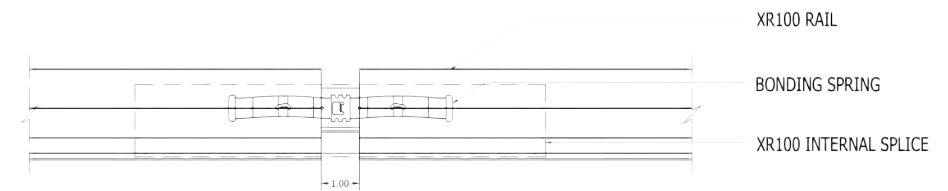

L DETAIL, THERMAL EXPANSION CONNECTION, XR100
6"=1'-0"

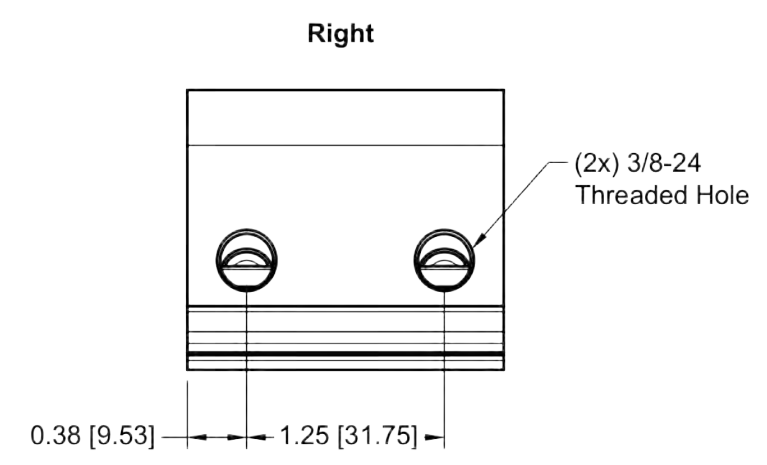
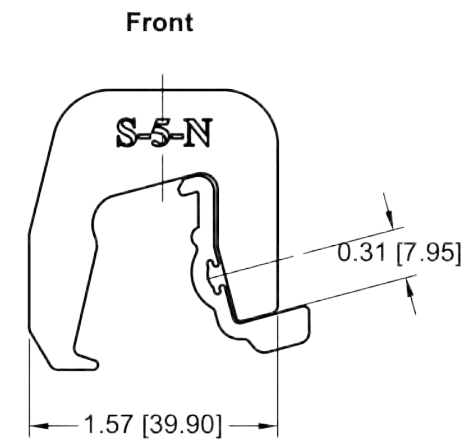
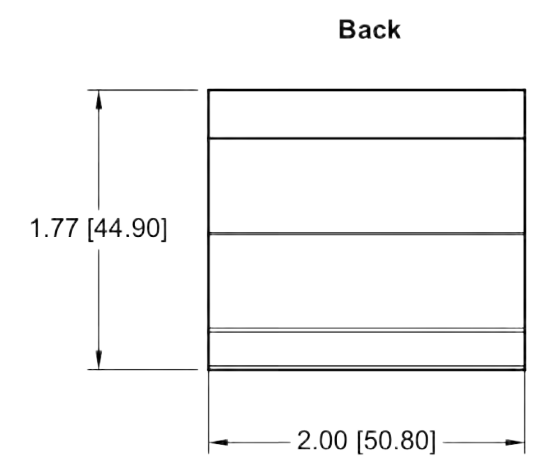
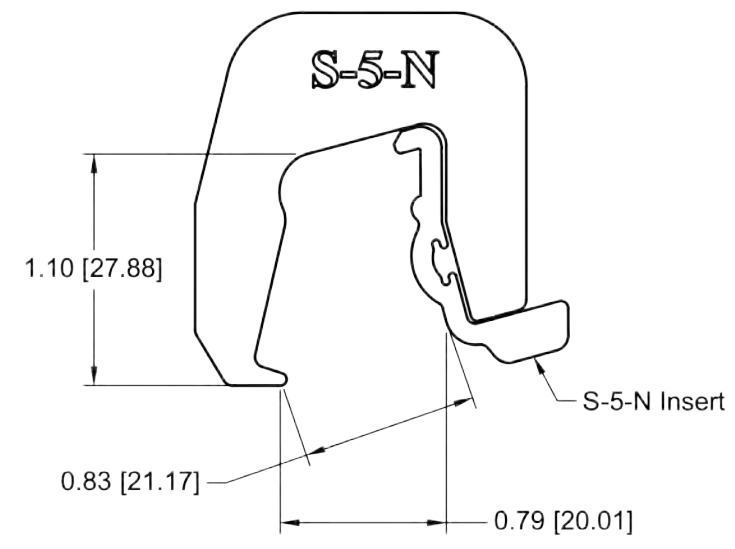
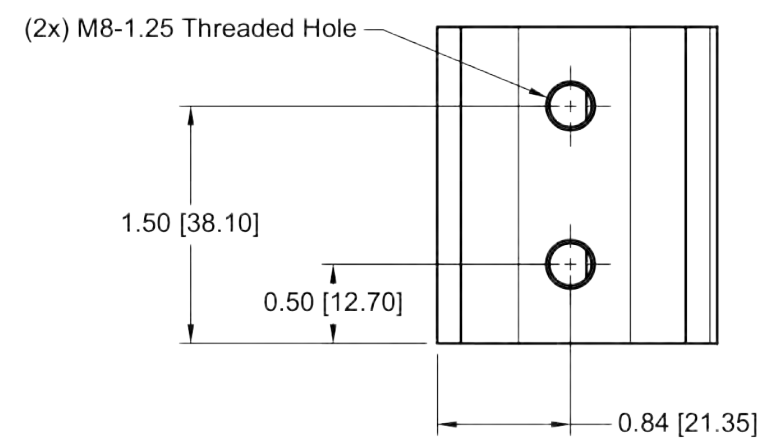
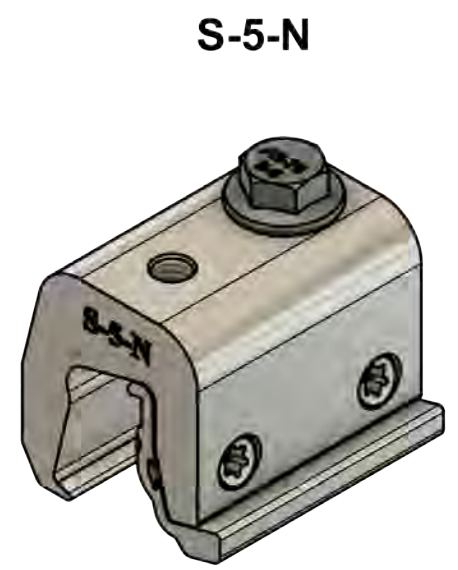

General Notes:

1. S-5-N Clamp
2. S-5-N Insert
3. 0.9" 3/8-24 T30 Drive Setscrew
4. M8-1.25 16 mm Bolt
5. Example Roof

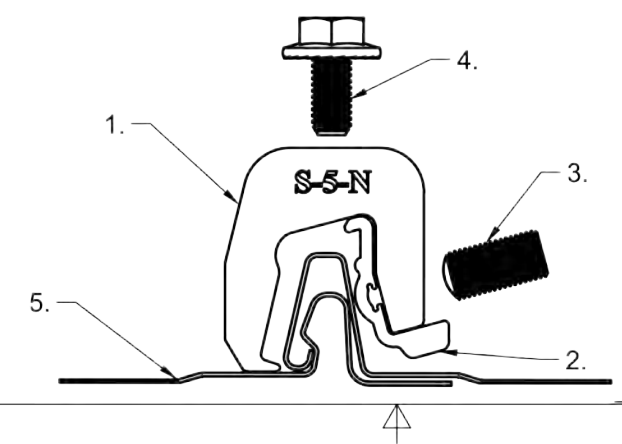

MATERIAL:	6000 Series AL		METAL ROOF INNOVATIONS, LTD.
EST ASSEMBLY WT:	.4065 lbs		8750 WALKER RD COLORADO SPRINGS, CO 80908 719-495-0518 719-495-0045 (FAX)
HARDWARE:	M8-1.25 16mm Bolt, 0.9" 3/8" T30 Setscrew	TITLE	S-5-N [CCD]
		DRAWING NO.	NG73-A-0-D
		DRAWN BY	SNLR
		DATE	3/8/2022
		SCALE	1:1
		FILE NAME	NG73-A-0-D (S-5-N) [CCD]
S-5!® PRODUCTS ARE PROTECTED BY MULTIPLE U.S. AND FOREIGN PATENTS. VISIT OUR WEBSITE AT WWW.S-5.COM FOR COMPLETE INFORMATION ON PATENTS AND TRADEMARKS			

REV#	DATE	REVISION NOTES
001	2/22/24	UPDATED CODE REFERENCES AND PW3
002	4/3/24	MOVED TILT ROW TO SOUTH EDGE OF ROOF PER CUSTOMER

Project Name:
KAREN ZETROUER

Project Address:
1262 SW BLUFF DR
FORT WHITE FL 32038

PAGE TITLE: ATTACHMENT DATA (CONT)

PAGE #: **S03B**



Tech Brief

AIRE

Racking Accelerated™

Aire® is a carefully-engineered, ergonomic racking system for pitched roofs—honoring both speed and precision. Each component has been designed to enforce a quality installation that can withstand the elements.

We've worked hand-in-glove with installers to provide the strongest, feature-rich, open-channel rail on the market. Two rail sizes come in black-anodized and mill finishes. Listed to UL 2703 and backed by a 25-year warranty.



Fully-Certified Cable Tray

Aire® is the only system listed as a cable tray. It uses NEC-compliant rail, with NEMA VE1 and C2.22 ratings. The high-strength open channel sheds water to keep wire connectors high and dry, while Wire Clips tame unruly PV & DG cables.

One-Tool 1/2" System

Glove-Friendly Components

Aire Lock® clamps are free-standing and universal, with Twist-n-Click® Technology for easy placement. The clamps do not impede wires in the tray below and they provide clean aesthetics with 1/2-inch module gaps.



Hassle-Free Rail Alignment

The Aire Dock® works with all of our attachments for composition shingle, tile, and metal roofs. The integrated bolt drops into open slots, allowing the rail to click-in and then easily Slide-n-Glide® into the optimal position.

Aire® Flush Mount System

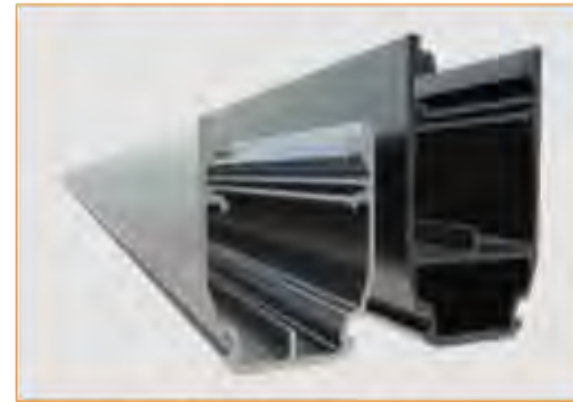

Two Optimized Aire® Rail Sizes

A1 Rail meets most load conditions, while the heftier A2 Rail is best in heavy-snow and high-wind regions.



Easy Hardware & Wire Placement

Quarter turn and Aire Lock® clamps stand freely. Wire Clips press in, with a flat-head slot for quick removal.

Racking Accelerated®



Internal Bonded Structural Splices

Aire® Ties connect two pieces of rail together without penetrations. Its water-relief "bridge" allows drainage.



Aesthetically-Pleasing Hidden Ends

Aire Lock® Stealth clamps module row ends. With a 15° angled bolt, rail cuts are not needed for access.

Rail Selection

The provided table* illustrates span differences for Aire® A1 and A2 Rails. It was prepared in compliance with applicable codes and standards.

Values based on the following criteria: ASCE 7-16, Gable Roof Flush Mount, Roof Zones 1 & 2e, Exposure B, Roof Slope of 8° to 20° and Mean Building Height of 30 ft.

Visit IronRidge.com for detailed certification letters.

External Load		Rail Span Between Attachments				
Snow (PSF)	Wind (MPH)	4'	5' 4"	6'	8'	10' 4"
None	120					
	150					
20	180	A1	A2			
	150					
30	180					
	150					
40	180					
	150					
80	180					
	150					
120	180					
	150					

Table is for illustration purposes only. Use approved certification letters for actual design guidance.



Designed By:



4509 NW 23rd Ave.
Suite 20
Gainesville, FL 32606
www.solarimpact.com
352.338.8221

REV#	DATE	REVISION NOTES
001	2/22/24	UPDATED CODE REFERENCES AND PW3
002	4/3/24	MOVED TILT ROW TO SOUTH EDGE OF ROOF PER CUSTOMER

Project Name:
KAREN ZETROUER

Project Address:
1262 SW BLUFF DR
FORT WHITE FL 32038

PAGE TITLE: RACKING DATA
PAGE #: S04