

COLUMBIA COUNTY Property Appraiser

Parcel 29-7S-17-10058-022

Owners

DUCKETT JOAN C
3035 SE WAKE RD
PORT ST LUCIE, FL 34984

Parcel Summary

Location	607 SW HEFLIN AVE
Use Code	0100: SINGLE FAMILY
Tax District	3: COUNTY
Acreage	5.0000
Section	29
Township	7S
Range	17
Subdivision	SANTA FE P

Legal Description

LOT 2 SANTA FE RIVER PLANTATIONS.

(DC FOR ROBERT THOMAS DUCKETT 1261-2783),
PROB 1264-588,



Working Values

	2026
Total Building	\$129,561
Total Extra Features	\$28,850
Total Market Land	\$76,500
Total Ag Land	\$0

	2026
Total Market	\$234,911
Total Assessed	\$234,911
Total Exempt	\$0
Total Taxable	\$234,911
SOH Diff	\$0

Value History

	2025	2024	2023	2022	2021	2020
Total Building	\$129,561	\$121,463	\$113,187	\$99,706	\$85,647	\$79,730
Total Extra Features	\$30,091	\$31,469	\$32,708	\$29,077	\$20,056	\$20,918
Total Market Land	\$76,500	\$76,500	\$76,500	\$76,500	\$53,125	\$53,125
Total Ag Land	\$0	\$0	\$0	\$0	\$0	\$0
Total Market	\$236,152	\$229,432	\$222,395	\$205,283	\$158,828	\$153,773
Total Assessed	\$236,152	\$143,988	\$139,794	\$135,722	\$131,769	\$129,950
Total Exempt	\$0	\$55,000	\$55,000	\$50,500	\$50,500	\$50,500
Total Taxable	\$236,152	\$88,988	\$84,794	\$85,222	\$81,269	\$79,450
SOH Diff	\$0	\$85,444	\$82,601	\$69,561	\$27,059	\$23,823

Document/Transfer/Sales History

Instrument / Official Record	Date	Q/U	Reason	Type	V/I	Sale Price	Ownership
<u>WD 0510/0032</u>	1983-03-01	<u>Q</u>		WARRANTY DEED	Vacant	\$12,000	

Buildings

Building # 1, Section # 1, 78306, SFR

Type	Models	Heated Sq Ft	Repl Cost New	YrBlt	Year Eff	Gross Area	Other % Dpr	Normal % Dpr	% Cond	Value
<u>0100</u>	<u>01</u>	1740	\$199,324	1995	1995	1,992	0.00%	35.00%	65.00%	\$129,561

Structural Elements

Type	Description	Code	Details
EW	Exterior Wall	08	WD OR PLY
RS	Roof Structure	03	GABLE/HIP
RC	Roof Cover	03	COMP SHNGL
IW	Interior Wall	05	DRYWALL
IF	Interior Flooring	08	SHT VINYL

Sub Areas

Type	Gross Area	Percent of Base	Adjusted Area
<u>BAS</u>	672	100%	672
<u>BAS</u>	1,068	100%	1,068
<u>FOP</u>	252	30%	76

Type	Description	Code	Details
AC	Air Conditioning	03	CENTRAL
HT	Heating Type	04	AIR DUCTED
BDR	Bedrooms	2.00	
BTH	Bathrooms	2.00	
FR	Frame	01	NONE
STR	Stories	1.	1.
AR	Architectual Type	05	CONV
COND	Condition Adjustment	03	03
KTCH	Kitchen Adjustment	01	01

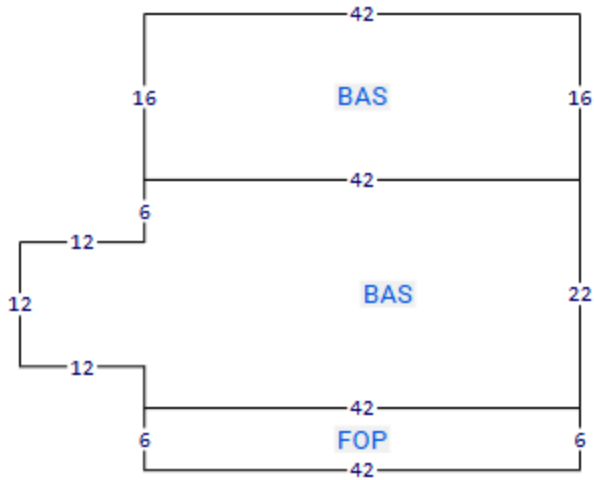

Extra Features

Code	Description	Length	Width	Units	Unit Price	AYB	% Good Condition	Final Value
0040	BARN,POLE	20	24	480.00	\$2.50	1995	100%	\$1,200
0280	POOL R/CON	14	28	392.00	\$70.00	2013	74%	\$20,306
0282	POOL ENCL	22	42	924.00	\$15.00	2013	40%	\$5,544
0080	DECKING	12	60	720.00	\$2.50	2013	100%	\$1,800

Land Lines

Code	Description	Zone	Front	Depth	Units	Rate/Unit	Acreage	Total Adj	Value
0100	SFR	00	.00	.00	5.00	\$18,000.00/AC	5.00	0.85	\$76,500

Personal Property

None

Permits

Date	Permit	Type	Status	Description
Jan 24, 2022	000043529	REROOF SFR	IMPORTED	Roof Replacement or Repair
May 7, 2013	30931	POOL ENCL	COMPLETED	POOL ENCL
May 3, 2013	30800	POOL	COMPLETED	POOL
Nov 17, 2010	28963	SFR	COMPLETED	SFR
	8860	SFR	COMPLETED	SFR

TRIM Notices

2025
2024
2023

Disclaimer

All parcel data on this page is for use by the Columbia County Assessor for assessment purposes only. The summary data on this page may not be a complete representation of the parcel or of the improvements thereon. Building information, including unit counts and number of permitted units, should be verified with the appropriate building and planning agencies. Zoning information should be verified with the appropriate planning agency. All parcels are reappraised each year. This is a true and accurate copy of the records of the Columbia County Assessor's Office as of February 02, 2026.