



Lumber design values are in accordance with ANSI/TPI 1 section 6.3  
 These truss designs rely on lumber values established by others.

RE: 5449020 -

MiTek, Inc.  
 16023 Swingley Ridge Rd.  
 Chesterfield, MO 63017  
 314.434.1200

**Site Information:**

Customer Info: IC CONSTRUCTION Project Name: Spec House Model: Custom  
 Lot/Block: 30 Subdivision: The Oaks  
 Address: TBD, TBD  
 City: Lake City State: FL

**Name Address and License # of Structural Engineer of Record, If there is one, for the building.**

Name: License #:  
 Address:  
 City: State:

**General Truss Engineering Criteria & Design Loads (Individual Truss Design Drawings Show Special Loading Conditions):**

Design Code: FBC2023/TPI2014 Design Program: MiTek 20/20 25.4  
 Wind Code: ASCE 7-22 Wind Speed: 130 mph  
 Roof Load: 40.0 psf Floor Load: N/A psf

This package includes 60 individual, Truss Design Drawings and 0 Additional Drawings.  
 With my seal affixed to this sheet, I hereby certify that I am the Truss Design Engineer and this index sheet conforms to 61G15-31.003, section 5 of the Florida Board of Professional Engineers Rules.

No.	Seal#	Truss Name	Date	No.	Seal#	Truss Name	Date
1	T41274273	CJ01	5/22/26	15	T41274287	PB02	5/22/26
2	T41274274	CJ02	5/22/26	16	T41274288	PB04	5/22/26
3	T41274275	EJ01	5/22/26	17	T41274289	PB04G	5/22/26
4	T41274276	EJ02	5/22/26	18	T41274290	T01	5/22/26
5	T41274277	EJ03	5/22/26	19	T41274291	T01G	5/22/26
6	T41274278	EJ04	5/22/26	20	T41274292	T02	5/22/26
7	T41274279	EJ04G	5/22/26	21	T41274293	T03	5/22/26
8	T41274280	EJ05	5/22/26	22	T41274294	T04	5/22/26
9	T41274281	EJ06	5/22/26	23	T41274295	T04G	5/22/26
10	T41274282	EJ07	5/22/26	24	T41274296	T05	5/22/26
11	T41274283	EJ08	5/22/26	25	T41274297	T05G	5/22/26
12	T41274284	HJ01	5/22/26	26	T41274298	T06	5/22/26
13	T41274285	PB01	5/22/26	27	T41274299	T07	5/22/26
14	T41274286	PB01G	5/22/26	28	T41274300	T08	5/22/26



This item has been digitally signed and sealed by ORegan, Philip, PE on the date adjacent to the seal.  
 Printed copies of this document are not considered signed and sealed and the signature must be verified on any electronic copies

The truss drawing(s) referenced above have been prepared by  
 MiTek USA, Inc. under my direct supervision based on the parameters  
 provided by Builders FirstSource-Lake City, FL.

Truss Design Engineer's Name: ORegan, Philip  
 My license renewal date for the state of Florida is February 28, 2027.

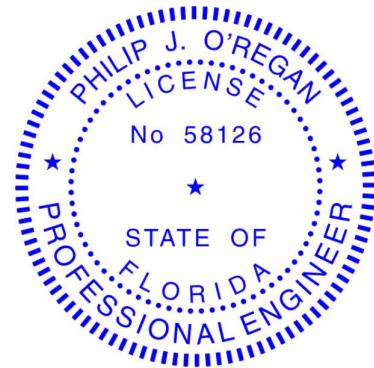

Philip J. O'Regan PE No.58126  
 MiTek Inc. DBA MiTek USA FL Cert 6634  
 16023 Swingley Ridge Rd. Chesterfield, MO 63017  
 Date:

**IMPORTANT NOTE:** The seal on these truss component designs is a certification that the engineer named is licensed in the jurisdiction(s) identified and that the designs comply with ANSI/TPI 1. These designs are based upon parameters shown (e.g., loads, supports, dimensions, shapes and design codes), which were given to MiTek or TRENCO. Any project specific information included is for MiTek's or TRENCO's customers file reference purpose only, and was not taken into account in the preparation of these designs. MiTek or TRENCO has not independently verified the applicability of the design parameters or the designs for any particular building. Before use, the building designer should verify applicability of design parameters and properly incorporate these designs into the overall building design per ANSI/TPI 1, Chapter 2.

May 22,2026



RE: 5449020 -

MiTek, Inc.  
16023 Swingley Ridge Rd.  
Chesterfield, MO 63017  
314.434.1200

**Site Information:**

Customer Info: IC CONSTRUCTION    Project Name: Spec House    Model: Custom  
Lot/Block: 30    Subdivision: The Oaks  
Address: TBD, TBD  
City: Lake City    State: FL

No.	Seal#	Truss Name	Date
29	T41274301	T09	5/22/26
30	T41274302	T10	5/22/26
31	T41274303	T11	5/22/26
32	T41274304	T12	5/22/26
33	T41274305	T12G	5/22/26
34	T41274306	T13	5/22/26
35	T41274307	T14	5/22/26
36	T41274308	T15	5/22/26
37	T41274309	T16	5/22/26
38	T41274310	T16G	5/22/26
39	T41274311	T17	5/22/26
40	T41274312	T17G	5/22/26
41	T41274313	T18	5/22/26
42	T41274314	T18G	5/22/26
43	T41274315	T19	5/22/26
44	T41274316	T20	5/22/26
45	T41274317	T21	5/22/26
46	T41274318	T21G	5/22/26
47	T41274319	T22	5/22/26
48	T41274320	T23	5/22/26
49	T41274321	T23G	5/22/26
50	T41274322	T24	5/22/26
51	T41274323	T24D	5/22/26
52	T41274324	T25	5/22/26
53	T41274325	T25G	5/22/26
54	T41274326	T26	5/22/26
55	T41274327	T27	5/22/26
56	T41274328	T27G	5/22/26
57	T41274329	T28	5/22/26
58	T41274330	T29	5/22/26
59	T41274331	TG01	5/22/26
60	T41274332	TG02	5/22/26

Job 5449020	Truss CJ01	Truss Type Jack-Open	Qty 1	Ply 1	Job Reference (optional) T41274273
----------------	---------------	-------------------------	----------	----------	---------------------------------------

Builders FirstSource (Lake City,FL), Lake City, FL - 32055,

Run: 25.40 S Apr 17 2026 Print: 25.4.0 S Apr 17 2026 MiTek Industries, Inc. Wed May 20 15:14:23  
ID:6BQ\_wpNpZ7ws0\_CHVfBw9zEcvc-RfC?PsB70Hq3NSgPqnL8w3uITXbGKWrCDoi7J4zJC?f

Page: 1

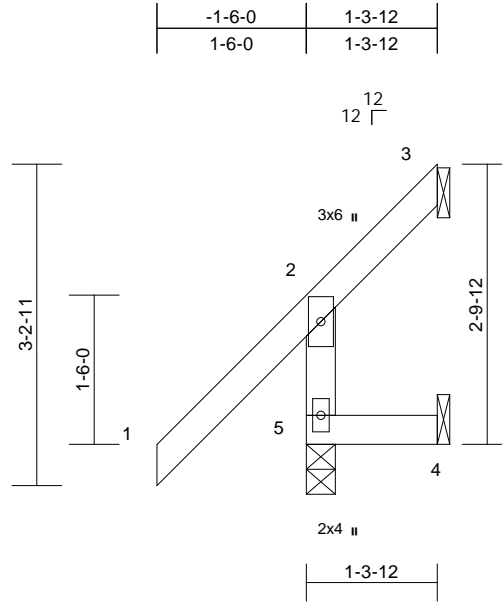

Scale = 1:23.1

Loading	(psf)	Spacing	2-0-0	CSI	DEFL	in	(loc)	l/defl	L/d	PLATES	GRIP	
TCLL (roof)	20.0	Plate Grip DOL	1.25	TC	0.37	Vert(LL)	0.00	4-5	>999	240	MT20	244/190
TCDL	10.0	Lumber DOL	1.25	BC	0.12	Vert(CT)	0.00	4-5	>999	180		
BCLL	0.0*	Rep Stress Incr	YES	WB	0.00	Horz(CT)	-0.01	3	n/a	n/a		
BCDL	10.0	Code	FBC2023/TPI2014	Matrix-MR							Weight: 10 lb	FT = 20%

#### LUMBER

TOP CHORD 2x4 SP No.2  
BOT CHORD 2x4 SP No.2  
WEBS 2x4 SP No.3

#### BRACING

TOP CHORD Structural wood sheathing directly applied, except end verticals.  
BOT CHORD Rigid ceiling directly applied or 10-0-0 oc bracing.

#### REACTIONS

(size) 3= Mechanical, 4= Mechanical,  
5=0-3-8  
Max Horiz 5=82 (LC 12)  
Max Uplift 3=-34 (LC 12), 4=-36 (LC 12), 5=-5 (LC 8)  
Max Grav 3=16 (LC 10), 4=33 (LC 10), 5=215 (LC 1)

#### FORCES

(lb) - Maximum Compression/Maximum Tension

TOP CHORD 2-5=-188/127, 1-2=0/70, 2-3=-63/54  
BOT CHORD 4-5=0/0

#### NOTES

- Unbalanced roof live loads have been considered for this design.
- Designed to ASCE 7-22 basic load combinations for allowable stress design unless otherwise noted.
- Wind: ASCE 7-22; Vult=130mph (3-second gust) Vasd=101mph; TC DL=4.2psf; BCDL=3.0psf; h=18ft; Cat. II; Exp B; Enclosed; MWFRS (envelope) exterior (2) zone and C-C Zone1 zone; end vertical left exposed; C-C for members and forces & MWFRS for reactions shown; Lumber DOL=1.60 plate grip DOL=1.60
- Building Designer / Project engineer responsible for verifying applied roof live load shown covers rain loading requirements specific to the use of this truss component.
- This truss has been designed for a 10.0 psf bottom chord live load nonconcurrent with any other live loads.

- \* This truss has been designed for a live load of 20.0psf on the bottom chord in all areas where a rectangle 3-06-00 tall by 2-00-00 wide will fit between the bottom chord and any other members.
- Refer to girder(s) for truss to truss connections.
- Provide mechanical connection (by others) of truss to bearing plate capable of withstanding 5 lb uplift at joint 5, 34 lb uplift at joint 3 and 36 lb uplift at joint 4.

LOAD CASE(S) Standard

This item has been digitally signed and sealed by ORegan, Philip, PE on the date indicated here. Printed copies of this document are not considered signed and sealed and the signature must be verified on any electronic copies.

Philip J. O'Regan PE No.58126  
MiTek Inc. DBA MiTek USA FL Cert 6634  
16023 Swingley Ridge Rd. Chesterfield, MO 63017  
Date:

May 22, 2026

#### WARNING - Verify design parameters and READ NOTES ON THIS AND INCLUDED MITEK REFERENCE PAGE MII-7473 rev. 1/2/2023 BEFORE USE.

Design valid for use only with MiTek® connectors. This design is based only upon parameters shown, and is for an individual building component, not a truss system. Before use, the building designer must verify the applicability of design parameters and properly incorporate this design into the overall building design. Bracing indicated is to prevent buckling of individual truss web and/or chord members only. Additional temporary and permanent bracing is always required for stability and to prevent collapse with possible personal injury and property damage. For general guidance regarding the fabrication, storage, delivery, erection and bracing of trusses and truss systems, see **ANSI/TPI1 Quality Criteria and DSB-22** available from Truss Plate Institute ([www.tpinst.org](http://www.tpinst.org)) and **BCSI Building Component Safety Information** available from the Structural Building Component Association ([www.sbcsccomponents.com](http://www.sbcsccomponents.com))

**MiTek®**

16023 Swingley Ridge Rd.  
Chesterfield, MO 63017  
314.434.1200 / MiTek-US.com

Job 5449020	Truss CJ02	Truss Type Jack-Open	Qty 1	Ply 1	Job Reference (optional) T41274274
----------------	---------------	-------------------------	----------	----------	---------------------------------------

Builders FirstSource (Lake City,FL), Lake City, FL - 32055,

Run: 25.40 S Apr 17 2026 Print: 25.4.0 S Apr 17 2026 MiTek Industries, Inc. Wed May 20 15:14:24  
ID:mfmXzP9eibZsmkWkAKFywMzEctl-RfC?PsB70Hq3NSgPqnL8w3uITXbGKWrCDoi7J4zJC?

Page: 1

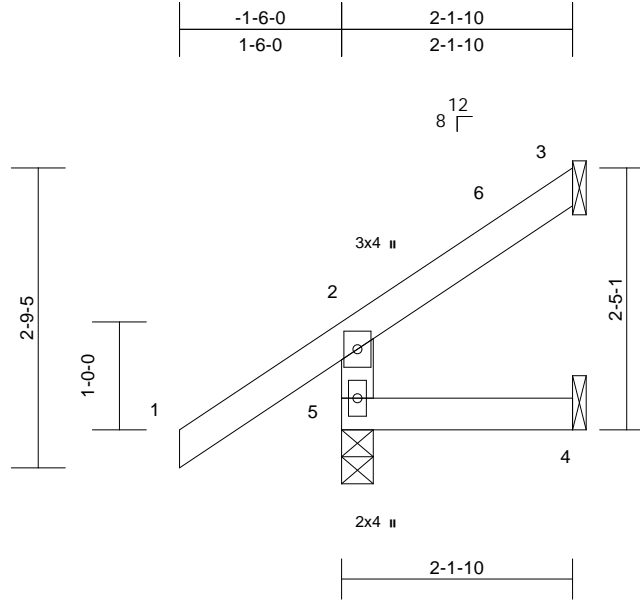

Scale = 1:21.3

Loading	(psf)	Spacing	2-0-0	CSI	DEFL	in	(loc)	l/defl	L/d	PLATES	GRIP	
TCLL (roof)	20.0	Plate Grip DOL	1.25	TC	0.30	Vert(LL)	0.00	4-5	>999	240	MT20	244/190
TCDL	10.0	Lumber DOL	1.25	BC	0.07	Vert(CT)	0.00	4-5	>999	180		
BCLL	0.0*	Rep Stress Incr	YES	WB	0.00	Horz(CT)	0.00	3	n/a	n/a		
BCDL	10.0	Code	FBC2023/TPI2014	Matrix-MR							Weight: 11 lb	FT = 20%

#### LUMBER

TOP CHORD 2x4 SP No.2  
BOT CHORD 2x4 SP No.2  
WEBS 2x4 SP No.3

#### BRACING

TOP CHORD Structural wood sheathing directly applied, except end verticals.  
BOT CHORD Rigid ceiling directly applied or 10-0-0 oc bracing.

#### REACTIONS

(size) 3= Mechanical, 4= Mechanical,  
5=0-3-8  
Max Horiz 5=76 (LC 12)  
Max Uplift 3=-39 (LC 12), 4=-6 (LC 12), 5=-43 (LC 12)  
Max Grav 3=37 (LC 19), 4=33 (LC 3), 5=218 (LC 1)

#### FORCES

(lb) - Maximum Compression/Maximum Tension

TOP CHORD 2-5=-188/180, 1-2=0/55, 2-3=-51/26  
BOT CHORD 4-5=0/0

#### NOTES

- Unbalanced roof live loads have been considered for this design.
- Designed to ASCE 7-22 basic load combinations for allowable stress design unless otherwise noted.
- Wind: ASCE 7-22; Vult=130mph (3-second gust) Vasd=101mph; TC DL=4.2psf; BCDL=3.0psf; h=18ft; Cat. II; Exp B; Enclosed; MWFRS (envelope) exterior (2) zone and C-C Zone3 -1-6-0 to 1-6-0, Zone1 1-6-0 to 2-0-14 zone; end vertical left exposed; C-C for members and forces & MWFRS for reactions shown; Lumber DOL=1.60 plate grip DOL=1.60
- Building Designer / Project engineer responsible for verifying applied roof live load shown covers rain loading requirements specific to the use of this truss component.
- This truss has been designed for a 10.0 psf bottom chord live load nonconcurrent with any other live loads.

- \* This truss has been designed for a live load of 20.0psf on the bottom chord in all areas where a rectangle 3-06-00 tall by 2-00-00 wide will fit between the bottom chord and any other members.
- Refer to girder(s) for truss to truss connections.
- Provide mechanical connection (by others) of truss to bearing plate capable of withstanding 43 lb uplift at joint 5, 39 lb uplift at joint 3 and 6 lb uplift at joint 4.

LOAD CASE(S) Standard

This item has been digitally signed and sealed by ORegan, Philip, PE on the date indicated here. Printed copies of this document are not considered signed and sealed and the signature must be verified on any electronic copies.

Philip J. O'Regan PE No.58126  
MiTek Inc. DBA MiTek USA FL Cert 6634  
16023 Swingley Ridge Rd. Chesterfield, MO 63017  
Date:

May 22, 2026

#### WARNING - Verify design parameters and READ NOTES ON THIS AND INCLUDED MITEK REFERENCE PAGE MII-7473 rev. 1/2/2023 BEFORE USE.

Design valid for use only with MiTek® connectors. This design is based only upon parameters shown, and is for an individual building component, not a truss system. Before use, the building designer must verify the applicability of design parameters and properly incorporate this design into the overall building design. Bracing indicated is to prevent buckling of individual truss web and/or chord members only. Additional temporary and permanent bracing is always required for stability and to prevent collapse with possible personal injury and property damage. For general guidance regarding the fabrication, storage, delivery, erection and bracing of trusses and truss systems, see **ANSI/TPI1 Quality Criteria and DSB-22** available from Truss Plate Institute ([www.tpinst.org](http://www.tpinst.org)) and **BCSI Building Component Safety Information** available from the Structural Building Component Association ([www.sbcsccomponents.com](http://www.sbcsccomponents.com))

**MiTek®**

16023 Swingley Ridge Rd.  
Chesterfield, MO 63017  
314.434.1200 / MiTek-US.com

Job 5449020	Truss EJ01	Truss Type Monopitch	Qty 2	Ply 1	Job Reference (optional) T41274275
----------------	---------------	-------------------------	----------	----------	---------------------------------------

Builders FirstSource (Lake City,FL), Lake City, FL - 32055,

Run: 25.40 S Apr 17 2026 Print: 25.4.0 S Apr 17 2026 MiTek Industries, Inc. Wed May 20 15:14:24

Page: 1

ID:bX3ZEHNf4?CED?lcDdXU6zEbnl-RfC?PsB70Hq3NSgPqnL8w3uITxbGKWrCDoi7J4zJC?

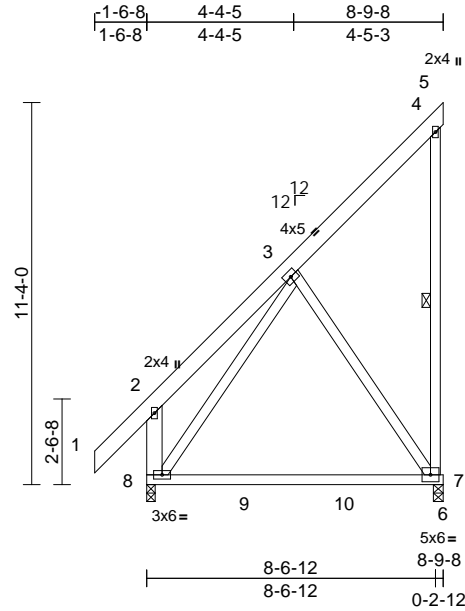

Scale = 1:68.3

Loading	(psf)	Spacing	2-0-0	CSI	DEFL	in	(loc)	l/defl	L/d	PLATES	GRIP
TCLL (roof)	20.0	Plate Grip DOL	1.25	TC	0.15	Vert(LL)	-0.33	7-8	>306	240	244/190
TCDL	10.0	Lumber DOL	1.25	BC	0.50	Vert(CT)	-0.54	7-8	>185	180	
BCLL	0.0*	Rep Stress Incr	YES	WB	0.47	Horz(CT)	0.00	7	n/a	n/a	
BCDL	10.0	Code	FBC2023/TPI2014	Matrix-MP						Weight: 90 lb	FT = 20%

**LUMBER**

TOP CHORD 2x6 SP No.2  
 BOT CHORD 2x4 SP 2700F 2.2E or 2x4 SP 2850F 2.0E or 2x4 SP M 31  
 WEBS 2x4 SP No.3 \*Except\* 8-2:2x6 SP No.2

**BRACING**

TOP CHORD Structural wood sheathing directly applied, except end verticals.  
 BOT CHORD Rigid ceiling directly applied or 10-0-0 oc bracing.  
 WEBS 1 Row at midpt 4-7

**REACTIONS**

(size) 7=0-3-8, 8=0-3-0  
 Max Horiz 8=357 (LC 12)  
 Max Uplift 7=366 (LC 12)  
 Max Grav 7=501 (LC 19), 8=482 (LC 21)

**FORCES**

(lb) - Maximum Compression/Maximum Tension  
 TOP CHORD 1-2=0/75, 2-3=-141/267, 3-4=-153/101, 4-5=-3/0, 4-7=-157/148, 2-8=-264/338  
 BOT CHORD 7-8=-209/189, 6-7=0/0  
 WEBS 3-7=-327/361, 3-8=-471/169

**NOTES**

- 1) Unbalanced roof live loads have been considered for this design.
- 2) Designed to ASCE 7-22 basic load combinations for allowable stress design unless otherwise noted.
- 3) Wind: ASCE 7-22; Vult=130mph (3-second gust) Vasd=101mph; TCDL=4.2psf; BCDL=3.0psf; h=18ft; Cat. II; Exp B; Enclosed; MWFRS (envelope) exterior (2) zone and C-C Zone1 zone; end vertical left exposed; C-C for members and forces & MWFRS for reactions shown; Lumber DOL=1.60 plate grip DOL=1.60
- 4) Building Designer / Project engineer responsible for verifying applied roof live load shown covers rain loading requirements specific to the use of this truss component.
- 5) This truss has been designed for a 10.0 psf bottom chord live load nonconcurrent with any other live loads.

- 6) \* This truss has been designed for a live load of 20.0psf on the bottom chord in all areas where a rectangle 3-06-00 tall by 2-00-00 wide will fit between the bottom chord and any other members, with BCDL = 10.0psf.
- 7) Provide mechanical connection (by others) of truss to bearing plate capable of withstanding 366 lb uplift at joint 7.

**LOAD CASE(S)** Standard

This item has been digitally signed and sealed by ORegan, Philip, PE on the date indicated here. Printed copies of this document are not considered signed and sealed and the signature must be verified on any electronic copies.

Philip J. O'Regan PE No.58126  
 MiTek Inc. DBA MiTek USA FL Cert 6634  
 16023 Swingley Ridge Rd. Chesterfield, MO 63017  
 Date:

May 22, 2026

**WARNING - Verify design parameters and READ NOTES ON THIS AND INCLUDED MITEK REFERENCE PAGE MII-7473 rev. 1/2/2023 BEFORE USE.**

Design valid for use only with MiTek® connectors. This design is based only upon parameters shown, and is for an individual building component, not a truss system. Before use, the building designer must verify the applicability of design parameters and properly incorporate this design into the overall building design. Bracing indicated is to prevent buckling of individual truss web and/or chord members only. Additional temporary and permanent bracing is always required for stability and to prevent collapse with possible personal injury and property damage. For general guidance regarding the fabrication, storage, delivery, erection and bracing of trusses and truss systems, see **ANSI/TPI1 Quality Criteria and DSB-22** available from Truss Plate Institute (www.tpinst.org) and **BCSI Building Component Safety Information** available from the Structural Building Component Association (www.sbcsccomponents.com)

**MiTek®**

16023 Swingley Ridge Rd.  
 Chesterfield, MO 63017  
 314.434.1200 / MiTek-US.com

Job 5449020	Truss EJ02	Truss Type Jack-Closed	Qty 2	Ply 1	Job Reference (optional) T41274276
----------------	---------------	---------------------------	----------	----------	---------------------------------------

Builders FirstSource (Lake City,FL), Lake City, FL - 32055,

Run: 25.40 S Apr 17 2026 Print: 25.4.0 S Apr 17 2026 MiTek Industries, Inc. Wed May 20 15:14:25  
ID:rXeOhAh5X3HVMC?l8g5dYbzEbmU-RfC?PsB70Hq3NSgPqnL8w3uITXbGKWrCDoi7J4zJC?f

Page: 1

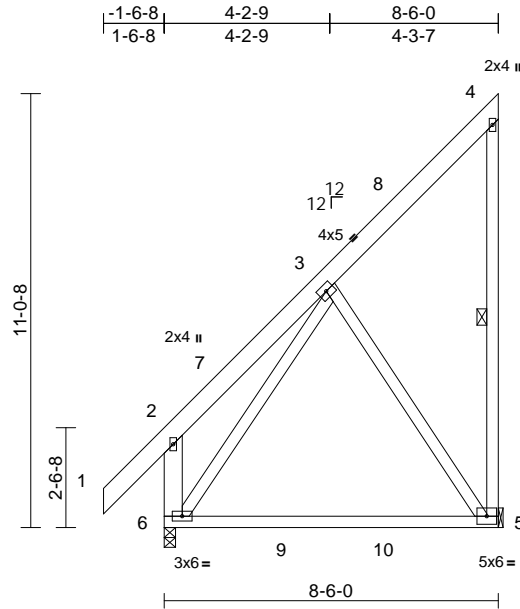

Scale = 1:58.6

Loading	(psf)	Spacing	2-0-0	CSI	DEFL	in	(loc)	l/defl	L/d	PLATES	GRIP	
TCLL (roof)	20.0	Plate Grip DOL	1.25	TC	0.18	Vert(LL)	-0.29	5-6	>340	240	MT20	244/190
TCDL	10.0	Lumber DOL	1.25	BC	0.46	Vert(CT)	-0.48	5-6	>203	180		
BCLL	0.0*	Rep Stress Incr	YES	WB	0.45	Horz(CT)	0.00	5	n/a	n/a		
BCDL	10.0	Code	FBC2023/TPI2014	Matrix-MP							Weight: 87 lb	FT = 20%

#### LUMBER

TOP CHORD 2x6 SP No.2  
BOT CHORD 2x4 SP 2700F 2.2E or 2x4 SP 2850F 2.0E or 2x4 SP M 31  
WEBS 2x4 SP No.3 \*Except\* 6-2:2x6 SP No.2

#### BRACING

TOP CHORD Structural wood sheathing directly applied, except end verticals.  
BOT CHORD Rigid ceiling directly applied or 10-0-0 oc bracing.  
WEBS 1 Row at midpt 4-5

#### REACTIONS

(size) 5= Mechanical, 6=0-3-8  
Max Horiz 6=314 (LC 12)  
Max Uplift 5=290 (LC 12)  
Max Grav 5=471 (LC 19), 6=464 (LC 20)

#### FORCES

(lb) - Maximum Compression/Maximum Tension  
TOP CHORD 1-2=0/75, 2-3=-138/308, 3-4=-123/73,  
4-5=-126/135, 2-6=-261/414  
BOT CHORD 5-6=-195/135  
WEBS 3-5=-231/335, 3-6=-478/99

#### NOTES

- Unbalanced roof live loads have been considered for this design.
- Designed to ASCE 7-22 basic load combinations for allowable stress design unless otherwise noted.
- Wind: ASCE 7-22; Vult=130mph (3-second gust)  
Vasd=101mph; TCDL=4.2psf; BCDL=3.0psf; h=18ft; Cat. II; Exp B; Enclosed; MWFRS (envelope) exterior (2) zone and C-C Zone3 -1-6-0 to 1-6-0, Zone1 1-6-0 to 8-4-12 zone; end vertical left exposed; C-C for members and forces & MWFRS for reactions shown; Lumber DOL=1.60 plate grip DOL=1.60
- Building Designer / Project engineer responsible for verifying applied roof live load shown covers rain loading requirements specific to the use of this truss component.
- This truss has been designed for a 10.0 psf bottom chord live load nonconcurrent with any other live loads.

- \* This truss has been designed for a live load of 20.0psf on the bottom chord in all areas where a rectangle 3-06-00 tall by 2-00-00 wide will fit between the bottom chord and any other members, with BCDL = 10.0psf.
- Refer to girder(s) for truss to truss connections.
- Provide mechanical connection (by others) of truss to bearing plate capable of withstanding 290 lb uplift at joint 5.

LOAD CASE(S) Standard

This item has been digitally signed and sealed by ORegan, Philip, PE on the date indicated here. Printed copies of this document are not considered signed and sealed and the signature must be verified on any electronic copies.

Philip J. O'Regan PE No.58126  
MiTek Inc. DBA MiTek USA FL Cert 6634  
16023 Swingley Ridge Rd. Chesterfield, MO 63017  
Date:

May 22, 2026

#### WARNING - Verify design parameters and READ NOTES ON THIS AND INCLUDED MITEK REFERENCE PAGE MII-7473 rev. 1/2/2023 BEFORE USE.

Design valid for use only with MiTek® connectors. This design is based only upon parameters shown, and is for an individual building component, not a truss system. Before use, the building designer must verify the applicability of design parameters and properly incorporate this design into the overall building design. Bracing indicated is to prevent buckling of individual truss web and/or chord members only. Additional temporary and permanent bracing is always required for stability and to prevent collapse with possible personal injury and property damage. For general guidance regarding the fabrication, storage, delivery, erection and bracing of trusses and truss systems, see **ANSI/TPI1 Quality Criteria and DSB-22** available from Truss Plate Institute ([www.tpinst.org](http://www.tpinst.org)) and **BCSI Building Component Safety Information** available from the Structural Building Component Association ([www.sbcsccomponents.com](http://www.sbcsccomponents.com))

**MiTek®**

16023 Swingley Ridge Rd.  
Chesterfield, MO 63017  
314.434.1200 / MiTek-US.com

Job 5449020	Truss EJ03	Truss Type Jack-Open	Qty 1	Ply 1	Job Reference (optional) T41274277
----------------	---------------	-------------------------	----------	----------	---------------------------------------

Builders FirstSource (Lake City,FL), Lake City, FL - 32055,

Run: 25.40 S Apr 17 2026 Print: 25.4.0 S Apr 17 2026 MiTek Industries, Inc. Wed May 20 15:14:25

Page: 1

ID:cLn2N5ekHucBZtaQWkzKXozEcsG-RfC?PsB70Hq3NSgPqnL8w3uTXbGKWrCDoi7J4zJC?&

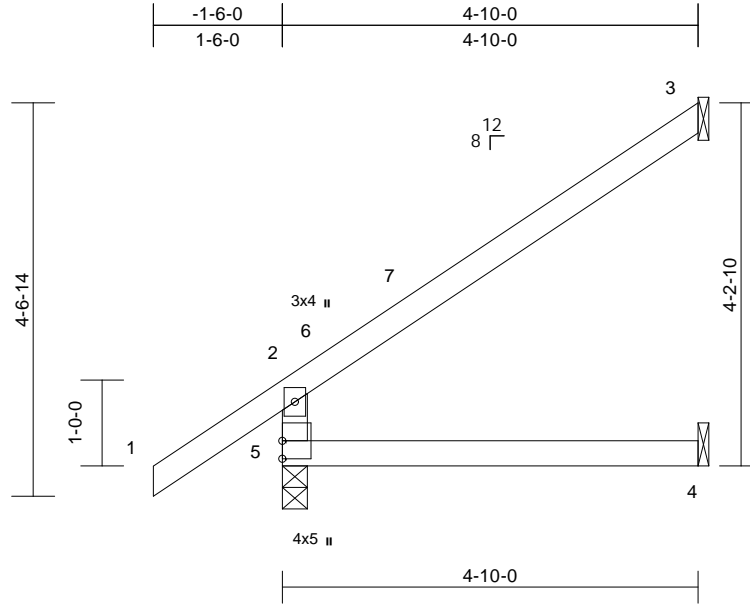

Scale = 1:26.8

Loading	(psf)	Spacing	2-0-0	CSI	DEFL	in	(loc)	l/defl	L/d	PLATES	GRIP	
TCLL (roof)	20.0	Plate Grip DOL	1.25	TC	0.44	Vert(LL)	0.03	4-5	>999	240	MT20	244/190
TCDL	10.0	Lumber DOL	1.25	BC	0.30	Vert(CT)	-0.05	4-5	>999	180		
BCLL	0.0*	Rep Stress Incr	YES	WB	0.00	Horz(CT)	-0.04	3	n/a	n/a		
BCDL	10.0	Code	FBC2023/TPI2014	Matrix-MR							Weight: 20 lb	FT = 20%

#### LUMBER

TOP CHORD 2x4 SP No.2  
BOT CHORD 2x4 SP No.2  
WEBS 2x4 SP No.3

#### BRACING

TOP CHORD Structural wood sheathing directly applied, except end verticals.  
BOT CHORD Rigid ceiling directly applied or 10-0-0 oc bracing.

#### REACTIONS

(size) 3= Mechanical, 4= Mechanical,  
5=0-3-8  
Max Horiz 5=145 (LC 12)  
Max Uplift 3=-101 (LC 12), 4=-8 (LC 12),  
5=-43 (LC 12)  
Max Grav 3=132 (LC 19), 4=87 (LC 3), 5=301  
(LC 1)

#### FORCES

(lb) - Maximum Compression/Maximum Tension

TOP CHORD 2-5=-258/197, 1-2=0/55, 2-3=-109/61  
BOT CHORD 4-5=0/0

#### NOTES

- Unbalanced roof live loads have been considered for this design.
- Designed to ASCE 7-22 basic load combinations for allowable stress design unless otherwise noted.
- Wind: ASCE 7-22; Vult=130mph (3-second gust) Vasd=101mph; TC DL=4.2psf; BCDL=3.0psf; h=18ft; Cat. II; Exp B; Enclosed; MWFRS (envelope) exterior (2) zone and C-C Zone3 -1-6-0 to 1-6-0, Zone1 1-6-0 to 4-9-4 zone; end vertical left exposed; C-C for members and forces & MWFRS for reactions shown; Lumber DOL=1.60 plate grip DOL=1.60
- Building Designer / Project engineer responsible for verifying applied roof live load shown covers rain loading requirements specific to the use of this truss component.
- This truss has been designed for a 10.0 psf bottom chord live load nonconcurrent with any other live loads.

- \* This truss has been designed for a live load of 20.0psf on the bottom chord in all areas where a rectangle 3-06-00 tall by 2-00-00 wide will fit between the bottom chord and any other members.
- Refer to girder(s) for truss to truss connections.
- Provide mechanical connection (by others) of truss to bearing plate capable of withstanding 43 lb uplift at joint 5, 101 lb uplift at joint 3 and 8 lb uplift at joint 4.

LOAD CASE(S) Standard

This item has been digitally signed and sealed by ORegan, Philip, PE on the date indicated here. Printed copies of this document are not considered signed and sealed and the signature must be verified on any electronic copies.

Philip J. O'Regan PE No.58126  
MiTek Inc. DBA MiTek USA FL Cert 6634  
16023 Swingley Ridge Rd. Chesterfield, MO 63017  
Date:

May 22, 2026

#### WARNING - Verify design parameters and READ NOTES ON THIS AND INCLUDED MITEK REFERENCE PAGE MII-7473 rev. 1/2/2023 BEFORE USE.

Design valid for use only with MiTek® connectors. This design is based only upon parameters shown, and is for an individual building component, not a truss system. Before use, the building designer must verify the applicability of design parameters and properly incorporate this design into the overall building design. Bracing indicated is to prevent buckling of individual truss web and/or chord members only. Additional temporary and permanent bracing is always required for stability and to prevent collapse with possible personal injury and property damage. For general guidance regarding the fabrication, storage, delivery, erection and bracing of trusses and truss systems, see ANSI/TPI1 Quality Criteria and DSB-22 available from Truss Plate Institute (www.tpinst.org) and BCSI Building Component Safety Information available from the Structural Building Component Association (www.sbcsccomponents.com)

**MiTek®**

16023 Swingley Ridge Rd.  
Chesterfield, MO 63017  
314.434.1200 / MiTek-US.com

Job 5449020	Truss EJ04	Truss Type Monopitch	Qty 3	Ply 1	Job Reference (optional)	T41274278
----------------	---------------	-------------------------	----------	----------	--------------------------	-----------

Builders FirstSource (Lake City,FL), Lake City, FL - 32055,

Run: 25.40 S Apr 17 2026 Print: 25.4.0 S Apr 17 2026 MiTek Industries, Inc. Wed May 20 15:14:25

Page: 1

ID:W3iznrkNkRuGkhd?CkTD9tzEciD-RfC?PsB70Hq3NSgPqnL8w3uITxBGKwRCDoi7J4zJC?f

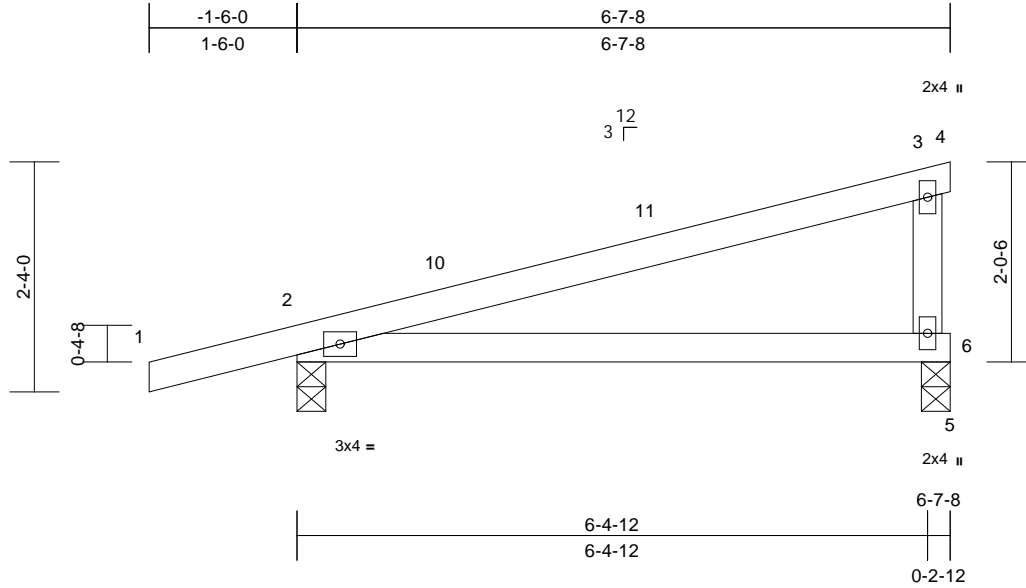

Scale = 1:23.4

Loading	(psf)	Spacing	2-0-0	CSI	DEFL	in	(loc)	l/defl	L/d	PLATES	GRIP	
TCLL (roof)	20.0	Plate Grip DOL	1.25	TC	0.54	Vert(LL)	0.09	6-9	>842	240	MT20	244/190
TCDL	10.0	Lumber DOL	1.25	BC	0.42	Vert(CT)	-0.16	6-9	>477	180		
BCLL	0.0*	Rep Stress Incr	YES	WB	0.00	Horz(CT)	0.01	2	n/a	n/a		
BCDL	10.0	Code	FBC2023/TPI2014	Matrix-MP							Weight: 25 lb	FT = 20%

#### LUMBER

TOP CHORD 2x4 SP No.2  
BOT CHORD 2x4 SP No.2  
WEBS 2x4 SP No.3

7) Provide mechanical connection (by others) of truss to bearing plate capable of withstanding 86 lb uplift at joint 6 and 141 lb uplift at joint 2.

LOAD CASE(S) Standard

#### BRACING

TOP CHORD Structural wood sheathing directly applied, except end verticals.  
BOT CHORD Rigid ceiling directly applied or 10-0-0 oc bracing.

#### REACTIONS

(size) 2=0-3-8, 6=0-3-8  
Max Horiz 2=83 (LC 8)  
Max Uplift 2=-141 (LC 8), 6=-86 (LC 12)  
Max Grav 2=356 (LC 1), 6=255 (LC 1)

#### FORCES

(lb) - Maximum Compression/Maximum Tension

TOP CHORD 1-2=0/22, 2-3=-110/32, 3-4=-1/0,  
3-6=-169/223  
BOT CHORD 2-6=-57/121, 5-6=0/0

#### NOTES

- Unbalanced roof live loads have been considered for this design.
- Designed to ASCE 7-22 basic load combinations for allowable stress design unless otherwise noted.
- Wind: ASCE 7-22; Vult=130mph (3-second gust) Vasd=101mph; TCDL=4.2psf; BCDL=3.0psf; h=18ft; Cat. II; Exp B; Enclosed; MWFRS (envelope) exterior (2) zone and C-C Zone3 -1-6-0 to 1-6-0, Zone1 1-6-0 to 6-7-8 zone;C-C for members and forces & MWFRS for reactions shown; Lumber DOL=1.60 plate grip DOL=1.60
- Building Designer / Project engineer responsible for verifying applied roof live load shown covers rain loading requirements specific to the use of this truss component.
- This truss has been designed for a 10.0 psf bottom chord live load nonconcurrent with any other live loads.
- \* This truss has been designed for a live load of 20.0psf on the bottom chord in all areas where a rectangle 3-06-00 tall by 2-00-00 wide will fit between the bottom chord and any other members.

This item has been digitally signed and sealed by ORegan, Philip, PE on the date indicated here. Printed copies of this document are not considered signed and sealed and the signature must be verified on any electronic copies.

Philip J. O'Regan PE No.58126  
MiTek Inc. DBA MiTek USA FL Cert 6634  
16023 Swingley Ridge Rd. Chesterfield, MO 63017  
Date:

May 22,2026

**WARNING - Verify design parameters and READ NOTES ON THIS AND INCLUDED MITEK REFERENCE PAGE MII-7473 rev. 1/2/2023 BEFORE USE.**

Design valid for use only with MiTek® connectors. This design is based only upon parameters shown, and is for an individual building component, not a truss system. Before use, the building designer must verify the applicability of design parameters and properly incorporate this design into the overall building design. Bracing indicated is to prevent buckling of individual truss web and/or chord members only. Additional temporary and permanent bracing is always required for stability and to prevent collapse with possible personal injury and property damage. For general guidance regarding the fabrication, storage, delivery, erection and bracing of trusses and truss systems, see **ANSI/TPI1 Quality Criteria and DSB-22** available from Truss Plate Institute ([www.tpinst.org](http://www.tpinst.org)) and **BCSI Building Component Safety Information** available from the Structural Building Component Association ([www.sbcsccomponents.com](http://www.sbcsccomponents.com))

**MiTek®**

16023 Swingley Ridge Rd.  
Chesterfield, MO 63017  
314.434.1200 / MiTek-US.com

Job 5449020	Truss EJ04G	Truss Type Monopitch Supported Gable	Qty 1	Ply 1	Job Reference (optional) T41274279
----------------	----------------	-----------------------------------------	----------	----------	---------------------------------------

Builders FirstSource (Lake City,FL), Lake City, FL - 32055,

Run: 25.40 S Apr 17 2026 Print: 25.4.0 S Apr 17 2026 MiTek Industries, Inc. Wed May 20 15:14:25

Page: 1

ID:604hHR6pRzosYS5yWIXUvQzEchk-RfC?PsB70Hq3NSgPqnL8w3ulTXbGKWrcDoi7J4zJC?f

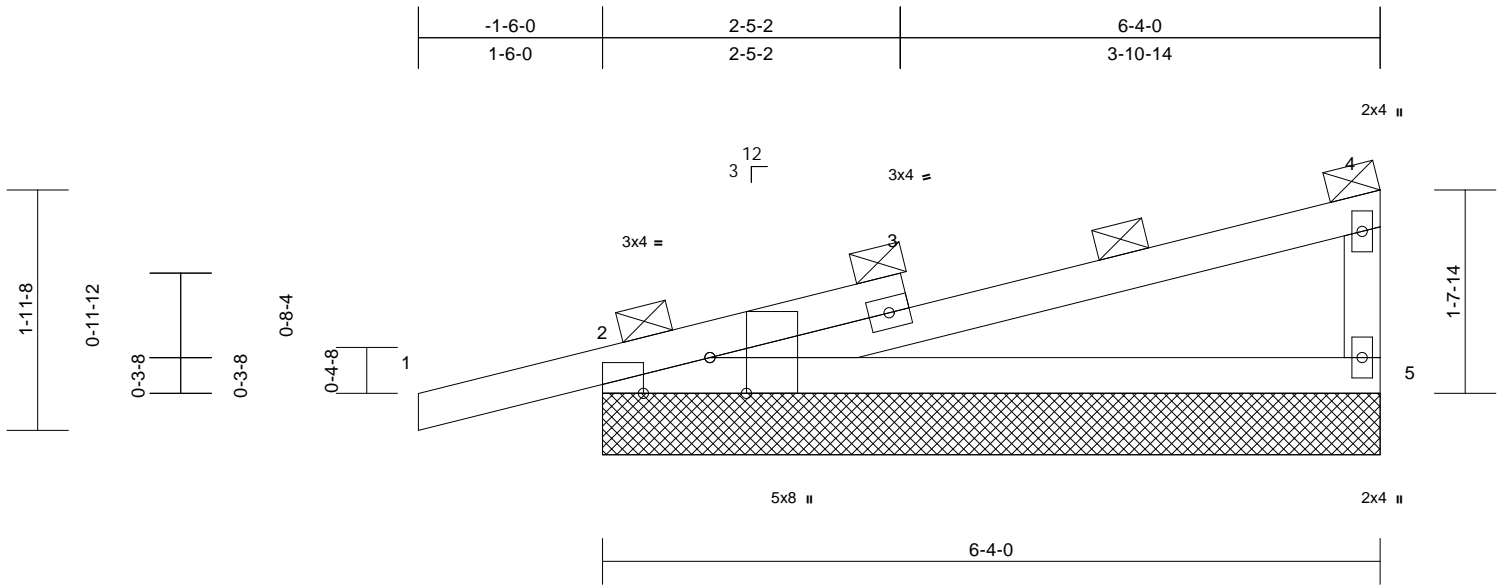

Scale = 1:18.8

Plate Offsets (X, Y): [2:0-3-8,Edge], [2:0-6-8,Edge]

Loading	(psf)	Spacing	2-0-0	CSI	DEFL	in	(loc)	l/defl	L/d	PLATES	GRIP	
TCLL (roof)	20.0	Plate Grip DOL	1.25	TC	0.77	Vert(LL)	n/a	-	n/a	999	MT20	244/190
TCDL	10.0	Lumber DOL	1.25	BC	0.49	Vert(CT)	n/a	-	n/a	999		
BCLL	0.0*	Rep Stress Incr	YES	WB	0.00	Horz(CT)	0.00	5	n/a	n/a		
BCDL	10.0	Code	FBC2023/TPI2014	Matrix-MP							Weight: 25 lb	FT = 20%

**LUMBER**  
TOP CHORD 2x4 SP No.2  
BOT CHORD 2x4 SP No.2  
WEBS 2x4 SP No.3

**BRACING**  
TOP CHORD 2-0-0 oc purlins, except end verticals.  
BOT CHORD Rigid ceiling directly applied or 10-0-0 oc bracing.

**REACTIONS** (size) 2=6-4-0, 5=6-4-0  
Max Horiz 2=67 (LC 8)  
Max Uplift 2=-143 (LC 8), 5=-75 (LC 12)  
Max Grav 2=348 (LC 1), 5=237 (LC 1)

**FORCES** (lb) - Maximum Compression/Maximum Tension  
TOP CHORD 1-2=0/22, 2-4=-81/33, 4-5=-175/262  
BOT CHORD 2-5=-1/1

- NOTES**
- Unbalanced roof live loads have been considered for this design.
  - Designed to ASCE 7-22 basic load combinations for allowable stress design unless otherwise noted.
  - Wind: ASCE 7-22; Vult=130mph (3-second gust) Vasd=101mph; TCDL=4.2psf; BCDL=3.0psf; h=18ft; Cat. II; Exp B; Enclosed; MWFRS (envelope) exterior (2) zone and C-C Zone3 zone;C-C for members and forces & MWFRS for reactions shown; Lumber DOL=1.60 plate grip DOL=1.60
  - Truss designed for wind loads in the plane of the truss only. For studs exposed to wind (normal to the face), see Standard Industry Gable End Details as applicable, or consult qualified building designer as per ANSI/TPI 1.
  - Building Designer / Project engineer responsible for verifying applied roof live load shown covers rain loading requirements specific to the use of this truss component.
  - Gable requires continuous bottom chord bearing.
  - Gable studs spaced at 2-0-0 oc.

- This truss has been designed for a 10.0 psf bottom chord live load nonconcurrent with any other live loads.
- \* This truss has been designed for a live load of 20.0psf on the bottom chord in all areas where a rectangle 3-06-00 tall by 2-00-00 wide will fit between the bottom chord and any other members.
- Provide mechanical connection (by others) of truss to bearing plate capable of withstanding 143 lb uplift at joint 2 and 75 lb uplift at joint 5.
- Graphical purlin representation does not depict the size or the orientation of the purlin along the top and/or bottom chord.

**LOAD CASE(S)** Standard

This item has been digitally signed and sealed by ORegan, Philip, PE on the date indicated here. Printed copies of this document are not considered signed and sealed and the signature must be verified on any electronic copies.

Philip J. O'Regan PE No.58126  
MiTek Inc. DBA MiTek USA FL Cert 6634  
16023 Swingley Ridge Rd. Chesterfield, MO 63017  
Date:

May 22,2026

**WARNING - Verify design parameters and READ NOTES ON THIS AND INCLUDED MITEK REFERENCE PAGE MII-7473 rev. 1/2/2023 BEFORE USE.**

Design valid for use only with MiTek® connectors. This design is based only upon parameters shown, and is for an individual building component, not a truss system. Before use, the building designer must verify the applicability of design parameters and properly incorporate this design into the overall building design. Bracing indicated is to prevent buckling of individual truss web and/or chord members only. Additional temporary and permanent bracing is always required for stability and to prevent collapse with possible personal injury and property damage. For general guidance regarding the fabrication, storage, delivery, erection and bracing of trusses and truss systems, see **ANSI/TPI1 Quality Criteria and DSB-22** available from Truss Plate Institute (www.tpinst.org) and **BCSI Building Component Safety Information** available from the Structural Building Component Association (www.sbcsccomponents.com)

**MiTek®**  
16023 Swingley Ridge Rd.  
Chesterfield, MO 63017  
314.434.1200 / MiTek-US.com



Job 5449020	Truss EJ06	Truss Type Monopitch	Qty 10	Ply 1	Job Reference (optional) T41274281
----------------	---------------	-------------------------	-----------	----------	---------------------------------------

Builders FirstSource (Lake City,FL), Lake City, FL - 32055,

Run: 25.40 S Apr 17 2026 Print: 25.4.0 S Apr 17 2026 MiTek Industries, Inc. Wed May 20 15:14:26  
ID:2UlpdtwSTiQ?NO\_kD4UwmlzEboqT-RfC?PsB70Hq3NSgPqnL8w3uITxbGKWrCDoi7J4zJC?F

Page: 1

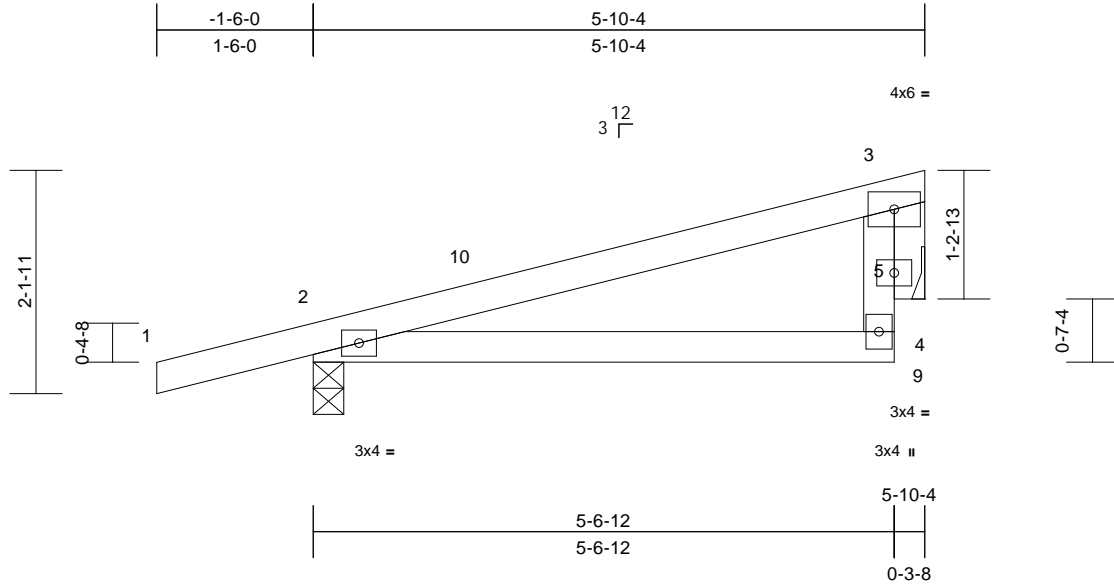

Scale = 1:22.1

Loading	(psf)	Spacing	2-0-0	CSI	DEFL	in	(loc)	l/defl	L/d	PLATES	GRIP	
TCLL (roof)	20.0	Plate Grip DOL	1.25	TC	0.37	Vert(LL)	0.03	4-8	>999	240	MT20	244/190
TCDL	10.0	Lumber DOL	1.25	BC	0.23	Vert(CT)	-0.04	4-8	>999	180		
BCLL	0.0*	Rep Stress Incr	YES	WB	0.00	Horz(CT)	0.00	2	n/a	n/a		
BCDL	10.0	Code	FBC2023/TPI2014	Matrix-MR							Weight: 23 lb	FT = 20%

**LUMBER**

TOP CHORD 2x4 SP No.2  
BOT CHORD 2x4 SP No.2  
WEBS 2x4 SP No.3  
OTHERS 2x4 SP No.3

**BRACING**

TOP CHORD Structural wood sheathing directly applied, except end verticals.  
BOT CHORD Rigid ceiling directly applied or 10-0-0 oc bracing.

**REACTIONS**

(size) 2=0-3-8, 9= Mechanical  
Max Horiz 2=72 (LC 8)  
Max Uplift 2=-189 (LC 8), 9=-106 (LC 8)  
Max Grav 2=332 (LC 1), 9=191 (LC 1)

**FORCES**

(lb) - Maximum Compression/Maximum Tension  
TOP CHORD 1-2=0/22, 2-3=-235/163, 4-5=-76/115, 3-5=-106/94  
BOT CHORD 2-4=-192/209  
WEBS 3-9=-96/49

**NOTES**

- 1) Unbalanced roof live loads have been considered for this design.
- 2) Designed to ASCE 7-22 basic load combinations for allowable stress design unless otherwise noted.
- 3) Wind: ASCE 7-22; Vult=130mph (3-second gust) Vasd=101mph; TC DL=4.2psf; BCDL=3.0psf; h=18ft; Cat. II; Exp B; Enclosed; MWFRS (envelope) exterior (2) zone and C-C Zone3 -1-6-0 to 1-6-0, Zone1 1-6-0 to 5-5-0 zone; porch left and right exposed; C-C for members and forces & MWFRS for reactions shown; Lumber DOL=1.60 plate grip DOL=1.60
- 4) Building Designer / Project engineer responsible for verifying applied roof live load shown covers rain loading requirements specific to the use of this truss component.
- 5) This truss has been designed for a 10.0 psf bottom chord live load nonconcurrent with any other live loads.

- 6) \* This truss has been designed for a live load of 20.0psf on the bottom chord in all areas where a rectangle 3-06-00 tall by 2-00-00 wide will fit between the bottom chord and any other members.
- 7) Refer to girder(s) for truss to truss connections.
- 8) Provide mechanical connection (by others) of truss to bearing plate capable of withstanding 189 lb uplift at joint 2 and 106 lb uplift at joint 9.

**LOAD CASE(S)** Standard

This item has been digitally signed and sealed by ORegan, Philip, PE on the date indicated here. Printed copies of this document are not considered signed and sealed and the signature must be verified on any electronic copies.

Philip J. O'Regan PE No.58126  
MiTek Inc. DBA MiTek USA FL Cert 6634  
16023 Swingley Ridge Rd. Chesterfield, MO 63017  
Date:

May 22, 2026

**WARNING - Verify design parameters and READ NOTES ON THIS AND INCLUDED MITEK REFERENCE PAGE MII-7473 rev. 1/2/2023 BEFORE USE.**

Design valid for use only with MiTek® connectors. This design is based only upon parameters shown, and is for an individual building component, not a truss system. Before use, the building designer must verify the applicability of design parameters and properly incorporate this design into the overall building design. Bracing indicated is to prevent buckling of individual truss web and/or chord members only. Additional temporary and permanent bracing is always required for stability and to prevent collapse with possible personal injury and property damage. For general guidance regarding the fabrication, storage, delivery, erection and bracing of trusses and truss systems, see **ANSI/TPI1 Quality Criteria and DSB-22** available from Truss Plate Institute (www.tpinst.org) and **BCSI Building Component Safety Information** available from the Structural Building Component Association (www.sbcsccomponents.com)

**MiTek®**

16023 Swingley Ridge Rd.  
Chesterfield, MO 63017  
314.434.1200 / MiTek-US.com

Job 5449020	Truss EJ07	Truss Type Jack-Closed	Qty 5	Ply 1	Job Reference (optional) T41274282
----------------	---------------	---------------------------	----------	----------	---------------------------------------

Builders FirstSource (Lake City,FL), Lake City, FL - 32055,

Run: 25.40 S Apr 17 2026 Print: 25.4.0 S Apr 17 2026 MiTek Industries, Inc. Wed May 20 15:14:26  
ID:egDtS5xLEtIbBhNhRsr7Z9zEcoQ-RfC?PsB70Hq3NSgPqnL8w3uITXbGKWrCDoi7J4zJC?f

Page: 1

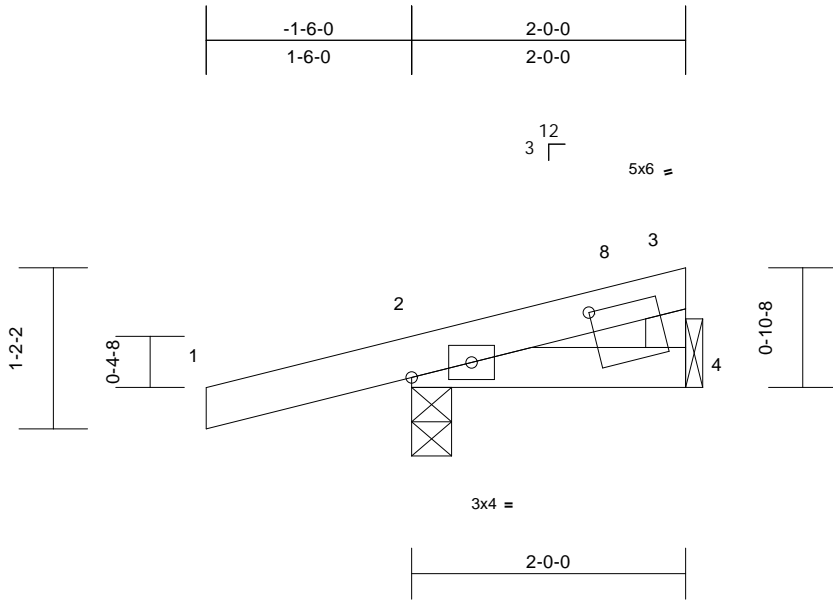

Scale = 1:16.8  
Plate Offsets (X, Y): [3:1-4-7,0-1-12]

Loading	(psf)	Spacing	2-0-0	CSI	DEFL	in	(loc)	l/defl	L/d	PLATES	GRIP	
TCLL (roof)	20.0	Plate Grip DOL	1.25	TC	0.16	Vert(LL)	0.00	7	>999	240	MT20	244/190
TCDL	10.0	Lumber DOL	1.25	BC	0.03	Vert(CT)	0.00	7	>999	180		
BCLL	0.0*	Rep Stress Incr	YES	WB	0.00	Horz(CT)	0.00	2	n/a	n/a		
BCDL	10.0	Code	FBC2023/TPI2014	Matrix-MP							Weight: 9 lb	FT = 20%

**LUMBER**  
TOP CHORD 2x4 SP No.2  
BOT CHORD 2x4 SP No.2  
WEBS 2x4 SP No.3

- 7) Refer to girder(s) for truss to truss connections.  
8) Provide mechanical connection (by others) of truss to bearing plate capable of withstanding 10 lb uplift at joint 4 and 111 lb uplift at joint 2.

**BRACING**  
TOP CHORD Structural wood sheathing directly applied, except end verticals.  
BOT CHORD Rigid ceiling directly applied or 10-0-0 oc bracing.

**LOAD CASE(S)** Standard

**REACTIONS** (size) 2=0-3-8, 4= Mechanical  
Max Horiz 2=37 (LC 8)  
Max Uplift 2=-111 (LC 8), 4=-10 (LC 12)  
Max Grav 2=201 (LC 1), 4=43 (LC 3)

**FORCES** (lb) - Maximum Compression/Maximum Tension  
TOP CHORD 1-2=0/22, 2-3=-102/50, 3-4=-31/24  
BOT CHORD 2-4=-48/93

- NOTES**  
1) Unbalanced roof live loads have been considered for this design.  
2) Designed to ASCE 7-22 basic load combinations for allowable stress design unless otherwise noted.  
3) Wind: ASCE 7-22; Vult=130mph (3-second gust) Vasd=101mph; TC DL=4.2psf; BCDL=3.0psf; h=18ft; Cat. II; Exp B; Enclosed; MWFRS (envelope) exterior (2) zone and C-C Zone3 -1-6-0 to 1-6-0, Zone1 1-6-0 to 1-10-4 zone;C-C for members and forces & MWFRS for reactions shown; Lumber DOL=1.60 plate grip DOL=1.60  
4) Building Designer / Project engineer responsible for verifying applied roof live load shown covers rain loading requirements specific to the use of this truss component.  
5) This truss has been designed for a 10.0 psf bottom chord live load nonconcurrent with any other live loads.  
6) \* This truss has been designed for a live load of 20.0psf on the bottom chord in all areas where a rectangle 3-06-00 tall by 2-00-00 wide will fit between the bottom chord and any other members.

This item has been digitally signed and sealed by ORegan, Philip, PE on the date indicated here. Printed copies of this document are not considered signed and sealed and the signature must be verified on any electronic copies.

Philip J. O'Regan PE No.58126  
MiTek Inc. DBA MiTek USA FL Cert 6634  
16023 Swingley Ridge Rd. Chesterfield, MO 63017  
Date:

May 22, 2026

**WARNING - Verify design parameters and READ NOTES ON THIS AND INCLUDED MITEK REFERENCE PAGE MII-7473 rev. 1/2/2023 BEFORE USE.**

Design valid for use only with MiTek® connectors. This design is based only upon parameters shown, and is for an individual building component, not a truss system. Before use, the building designer must verify the applicability of design parameters and properly incorporate this design into the overall building design. Bracing indicated is to prevent buckling of individual truss web and/or chord members only. Additional temporary and permanent bracing is always required for stability and to prevent collapse with possible personal injury and property damage. For general guidance regarding the fabrication, storage, delivery, erection and bracing of trusses and truss systems, see **ANSI/TPI1 Quality Criteria and DSB-22** available from Truss Plate Institute (www.tpinst.org) and **BCSI Building Component Safety Information** available from the Structural Building Component Association (www.sbcsccomponents.com)

**MiTek®**

16023 Swingley Ridge Rd.  
Chesterfield, MO 63017  
314.434.1200 / MiTek-US.com

Job 5449020	Truss EJ08	Truss Type Monopitch Supported Gable	Qty 2	Ply 1	Job Reference (optional) T41274283
----------------	---------------	-----------------------------------------	----------	----------	---------------------------------------

Builders FirstSource (Lake City,FL), Lake City, FL - 32055,

Run: 25.40 S Apr 17 2026 Print: 25.4.0 S Apr 17 2026 MiTek Industries, Inc. Wed May 20 15:14:26  
ID:PDIV8q1MLwtS9v\_EvY??urzeCol-RFC?PsB70Hq3NSgPqnL8w3uITXbGKWrCDoi7J4zJC?f

Page: 1

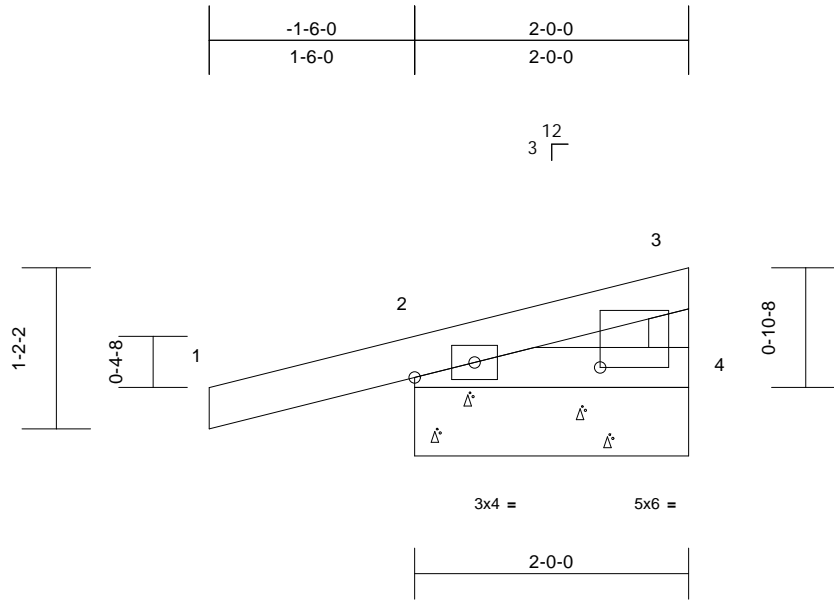

Scale = 1:16.8

Plate Offsets (X, Y): [4:1-4-4,0-0-14]

Loading	(psf)	Spacing	2-0-0	CSI	DEFL	in	(loc)	l/defl	L/d	PLATES	GRIP	
TCLL (roof)	20.0	Plate Grip DOL	1.25	TC	0.21	Vert(LL)	n/a	-	n/a	999	MT20	244/190
TCDL	10.0	Lumber DOL	1.25	BC	0.03	Vert(CT)	n/a	-	n/a	999		
BCLL	0.0*	Rep Stress Incr	YES	WB	0.00	Horz(CT)	0.00	2	n/a	n/a		
BCDL	10.0	Code	FBC2023/TPI2014	Matrix-MP							Weight: 9 lb	FT = 20%

**LUMBER**

TOP CHORD 2x4 SP No.2  
BOT CHORD 2x4 SP No.2  
WEBS 2x4 SP No.3

**BRACING**

TOP CHORD Structural wood sheathing directly applied, except end verticals.  
BOT CHORD Rigid ceiling directly applied or 10-0-0 oc bracing.

**REACTIONS**

(size) 2=2-0-0, 4=2-0-0  
Max Horiz 2=37 (LC 8)  
Max Uplift 2=-111 (LC 8), 4=-9 (LC 12)  
Max Grav 2=200 (LC 1), 4=50 (LC 3)

**FORCES**

(lb) - Maximum Compression/Maximum Tension

TOP CHORD 1-2=0/22, 2-3=-129/50, 3-4=-31/37  
BOT CHORD 2-4=-48/116

**NOTES**

- 1) Unbalanced roof live loads have been considered for this design.
- 2) Designed to ASCE 7-22 basic load combinations for allowable stress design unless otherwise noted.
- 3) Wind: ASCE 7-22; Vult=130mph (3-second gust) Vasd=101mph; TCDL=4.2psf; BCDL=3.0psf; h=18ft; Cat. II; Exp B; Enclosed; MWFRS (envelope) exterior (2) zone and C-C Zone3 zone;C-C for members and forces & MWFRS for reactions shown; Lumber DOL=1.60 plate grip DOL=1.60
- 4) Truss designed for wind loads in the plane of the truss only. For studs exposed to wind (normal to the face), see Standard Industry Gable End Details as applicable, or consult qualified building designer as per ANSI/TPI 1.
- 5) Building Designer / Project engineer responsible for verifying applied roof live load shown covers rain loading requirements specific to the use of this truss component.
- 6) Gable requires continuous bottom chord bearing.
- 7) Gable studs spaced at 1-4-0 oc.

- 8) This truss has been designed for a 10.0 psf bottom chord live load nonconcurrent with any other live loads.
- 9) \* This truss has been designed for a live load of 20.0psf on the bottom chord in all areas where a rectangle 3-06-00 tall by 2-00-00 wide will fit between the bottom chord and any other members.
- 10) Provide mechanical connection (by others) of truss to bearing plate capable of withstanding 111 lb uplift at joint 2, 9 lb uplift at joint 4 and 111 lb uplift at joint 2.

**LOAD CASE(S)** Standard

This item has been digitally signed and sealed by ORegan, Philip, PE on the date indicated here. Printed copies of this document are not considered signed and sealed and the signature must be verified on any electronic copies.

Philip J. O'Regan PE No.58126  
MiTek Inc. DBA MiTek USA FL Cert 6634  
16023 Swingley Ridge Rd. Chesterfield, MO 63017  
Date:

May 22,2026

**WARNING - Verify design parameters and READ NOTES ON THIS AND INCLUDED MITEK REFERENCE PAGE MII-7473 rev. 1/2/2023 BEFORE USE.**

Design valid for use only with MiTek® connectors. This design is based only upon parameters shown, and is for an individual building component, not a truss system. Before use, the building designer must verify the applicability of design parameters and properly incorporate this design into the overall building design. Bracing indicated is to prevent buckling of individual truss web and/or chord members only. Additional temporary and permanent bracing is always required for stability and to prevent collapse with possible personal injury and property damage. For general guidance regarding the fabrication, storage, delivery, erection and bracing of trusses and truss systems, see **ANSI/TPI1 Quality Criteria and DSB-22** available from Truss Plate Institute (www.tpinst.org) and **BCSI Building Component Safety Information** available from the Structural Building Component Association (www.sbcsccomponents.com)

**MiTek®**

16023 Swingley Ridge Rd.  
Chesterfield, MO 63017  
314.434.1200 / MiTek-US.com

Job 5449020	Truss HJ01	Truss Type Diagonal Hip Girder	Qty 1	Ply 1	Job Reference (optional) T41274284
----------------	---------------	-----------------------------------	----------	----------	---------------------------------------

Builders FirstSource (Lake City,FL), Lake City, FL - 32055,

Run: 25.40 S Apr 17 2026 Print: 25.4.0 S Apr 17 2026 MiTek Industries, Inc. Wed May 20 15:14:26  
ID:UrV8eeUaLuz1Vt4wFVEHW3zEcst-RfC?PsB70Hq3NSgPqnL8w3ulTXbGKWrCDoi7J4zJC?f

Page: 1

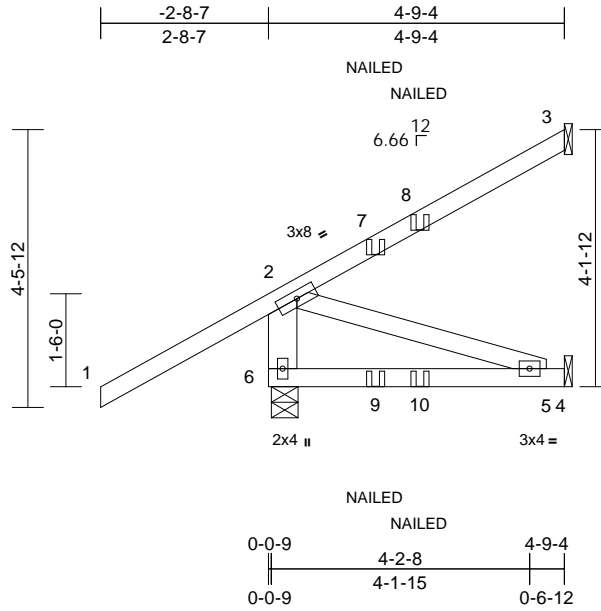

Scale = 1:37.1

Loading	(psf)	Spacing	2-0-0	CSI	DEFL	in	(loc)	l/defl	L/d	PLATES	GRIP	
TCLL (roof)	20.0	Plate Grip DOL	1.25	TC	0.68	Vert(LL)	-0.02	5-6	>999	240	244/190	
TCDL	10.0	Lumber DOL	1.25	BC	0.27	Vert(CT)	-0.05	5-6	>999	180		
BCLL	0.0*	Rep Stress Incr	NO	WB	0.04	Horz(CT)	0.00	3	n/a	n/a		
BCDL	10.0	Code	FBC2023/TPI2014	Matrix-MP								
											Weight: 29 lb	FT = 20%

#### LUMBER

TOP CHORD 2x4 SP No.2  
BOT CHORD 2x4 SP No.2  
WEBS 2x6 SP No.2 \*Except\* 5-2:2x4 SP No.3

#### BRACING

TOP CHORD Structural wood sheathing directly applied, except end verticals.  
BOT CHORD Rigid ceiling directly applied or 10-0-0 oc bracing.

#### REACTIONS

(size) 3= Mechanical, 4= Mechanical, 6=0-5-3  
Max Horiz 6=132 (LC 8)  
Max Uplift 3=-71 (LC 8), 4=-50 (LC 8), 6=-128 (LC 8)  
Max Grav 3=80 (LC 15), 4=90 (LC 3), 6=393 (LC 1)

#### FORCES

(lb) - Maximum Compression/Maximum Tension  
TOP CHORD 2-6=-353/114, 1-2=0/85, 2-3=-117/28  
BOT CHORD 5-6=-141/49, 4-5=0/0  
WEBS 2-5=-51/148

#### NOTES

- 1) Unbalanced roof live loads have been considered for this design.
- 2) Designed to ASCE 7-22 basic load combinations for allowable stress design unless otherwise noted.
- 3) Wind: ASCE 7-22; Vult=130mph (3-second gust) Vasd=101mph; TCDL=4.2psf; BCDL=3.0psf; h=18ft; Cat. II; Exp B; Enclosed; MWFRS (envelope) exterior (2) zone; end vertical left exposed; Lumber DOL=1.60 plate grip DOL=1.60
- 4) Building Designer / Project engineer responsible for verifying applied roof live load shown covers rain loading requirements specific to the use of this truss component.
- 5) This truss has been designed for a 10.0 psf bottom chord live load nonconcurrent with any other live loads.

- 6) \* This truss has been designed for a live load of 20.0psf on the bottom chord in all areas where a rectangle 3-06-00 tall by 2-00-00 wide will fit between the bottom chord and any other members.
- 7) Refer to girder(s) for truss to truss connections.
- 8) Provide mechanical connection (by others) of truss to bearing plate capable of withstanding 128 lb uplift at joint 6, 71 lb uplift at joint 3 and 50 lb uplift at joint 4.
- 9) "NAILED" indicates 3-10d (0.148"x3") or 2-12d (0.148"x3.25") toe-nails per NDS guidelines.
- 10) In the LOAD CASE(S) section, loads applied to the face of the truss are noted as front (F) or back (B).

#### LOAD CASE(S) Standard

- 1) Dead + Roof Live (balanced): Lumber Increase=1.25, Plate Increase=1.25  
Uniform Loads (lb/ft)  
Vert: 1-2=-60, 2-3=-60, 4-6=-20  
Concentrated Loads (lb)  
Vert: 8=30 (F), 9=6 (B)

This item has been digitally signed and sealed by ORegan, Philip, PE on the date indicated here. Printed copies of this document are not considered signed and sealed and the signature must be verified on any electronic copies.

Philip J. O'Regan PE No.58126  
MiTek Inc. DBA MiTek USA FL Cert 6634  
16023 Swingley Ridge Rd. Chesterfield, MO 63017  
Date:

May 22, 2026

#### WARNING - Verify design parameters and READ NOTES ON THIS AND INCLUDED MITEK REFERENCE PAGE MII-7473 rev. 1/2/2023 BEFORE USE.

Design valid for use only with MiTek® connectors. This design is based only upon parameters shown, and is for an individual building component, not a truss system. Before use, the building designer must verify the applicability of design parameters and properly incorporate this design into the overall building design. Bracing indicated is to prevent buckling of individual truss web and/or chord members only. Additional temporary and permanent bracing is always required for stability and to prevent collapse with possible personal injury and property damage. For general guidance regarding the fabrication, storage, delivery, erection and bracing of trusses and truss systems, see **ANSI/TPI1 Quality Criteria and DSB-22** available from Truss Plate Institute ([www.tpinst.org](http://www.tpinst.org)) and **BCSI Building Component Safety Information** available from the Structural Building Component Association ([www.sbcsccomponents.com](http://www.sbcsccomponents.com))

**MiTek®**

16023 Swingley Ridge Rd.  
Chesterfield, MO 63017  
314.434.1200 / MiTek-US.com

Job 5449020	Truss PB01	Truss Type Piggyback	Qty 26	Ply 1	Job Reference (optional) T41274285
----------------	---------------	-------------------------	-----------	----------	---------------------------------------

Builders FirstSource (Lake City,FL), Lake City, FL - 32055,

Run: 25.40 S Apr 17 2026 Print: 25.4.0 S Apr 17 2026 MiTek Industries, Inc. Wed May 20 15:14:26  
ID:Ztx7uYaBTBuoL\_pj4cDRGzEbPo-RfC?PsB70Hq3NSgPqnL8w3uITXbGKWrCDoi7J4zJC?

Page: 1

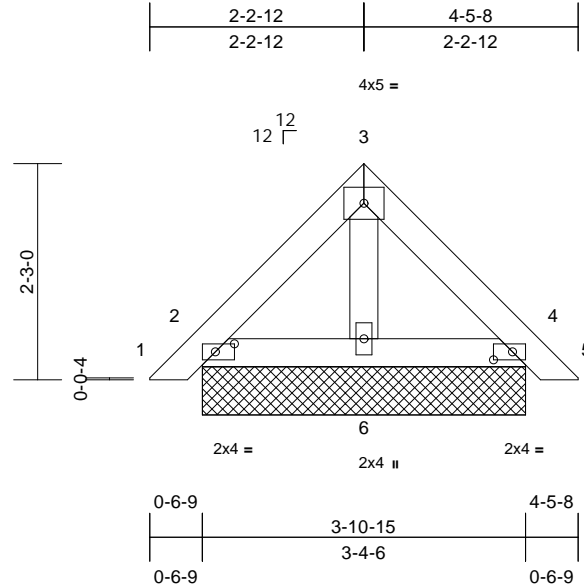

Scale = 1:24

Plate Offsets (X, Y): [2:0-2-6,0-1-0], [4:0-2-6,0-1-0]

Loading	(psf)	Spacing	2-0-0	CSI	DEFL	in	(loc)	l/defl	L/d	PLATES	GRIP	
TCLL (roof)	20.0	Plate Grip DOL	1.25	TC	0.05	Vert(LL)	n/a	-	n/a	999	MT20	244/190
TCDL	10.0	Lumber DOL	1.25	BC	0.06	Vert(CT)	n/a	-	n/a	999		
BCLL	0.0*	Rep Stress Incr	YES	WB	0.01	Horz(CT)	0.00	4	n/a	n/a		
BCDL	10.0	Code	FBC2023/TPI2014	Matrix-MP							Weight: 17 lb	FT = 20%

#### LUMBER

TOP CHORD 2x4 SP No.2  
BOT CHORD 2x4 SP No.2  
OTHERS 2x4 SP No.3

#### BRACING

TOP CHORD Structural wood sheathing directly applied.  
BOT CHORD Rigid ceiling directly applied or 10-0-0 oc bracing.

#### REACTIONS

(size) 2=3-4-6, 4=3-4-6, 6=3-4-6  
Max Horiz 2=50 (LC 11)  
Max Uplift 2=-26 (LC 13), 4=-32 (LC 13),  
6=-18 (LC 12)  
Max Grav 2=103 (LC 1), 4=103 (LC 1), 6=105 (LC 1)

#### FORCES

(lb) - Maximum Compression/Maximum Tension

TOP CHORD 1-2=0/15, 2-3=-64/69, 3-4=-60/64, 4-5=0/15  
BOT CHORD 2-6=-17/69, 4-6=-13/69  
WEBS 3-6=-38/1

#### NOTES

- 1) Unbalanced roof live loads have been considered for this design.
- 2) Designed to ASCE 7-22 basic load combinations for allowable stress design unless otherwise noted.
- 3) Wind: ASCE 7-22; Vult=130mph (3-second gust) Vasd=101mph; TC DL=4.2psf; BCDL=3.0psf; h=18ft; Cat. II; Exp B; Enclosed; MWFRS (envelope) exterior (2) zone and C-C Zone3 zone; C-C for members and forces & MWFRS for reactions shown; Lumber DOL=1.60 plate grip DOL=1.60
- 4) Truss designed for wind loads in the plane of the truss only. For studs exposed to wind (normal to the face), see Standard Industry Gable End Details as applicable, or consult qualified building designer as per ANSI/TPI 1.
- 5) Building Designer / Project engineer responsible for verifying applied roof live load shown covers rain loading requirements specific to the use of this truss component.
- 6) Gable requires continuous bottom chord bearing.

- 7) Gable studs spaced at 4-0-0 oc.
- 8) This truss has been designed for a 10.0 psf bottom chord live load nonconcurrent with any other live loads.
- 9) \* This truss has been designed for a live load of 20.0psf on the bottom chord in all areas where a rectangle 3-06-00 tall by 2-00-00 wide will fit between the bottom chord and any other members.
- 10) Provide mechanical connection (by others) of truss to bearing plate capable of withstanding 26 lb uplift at joint 2, 32 lb uplift at joint 4, 18 lb uplift at joint 6, 26 lb uplift at joint 2 and 32 lb uplift at joint 4.
- 11) See Standard Industry Piggyback Truss Connection Detail for Connection to base truss as applicable, or consult qualified building designer.

LOAD CASE(S) Standard

This item has been digitally signed and sealed by ORegan, Philip, PE on the date indicated here. Printed copies of this document are not considered signed and sealed and the signature must be verified on any electronic copies.

Philip J. O'Regan PE No.58126  
MiTek Inc. DBA MiTek USA FL Cert 6634  
16023 Swingley Ridge Rd. Chesterfield, MO 63017  
Date:

May 22, 2026

#### WARNING - Verify design parameters and READ NOTES ON THIS AND INCLUDED MITEK REFERENCE PAGE MII-7473 rev. 1/2/2023 BEFORE USE.

Design valid for use only with MiTek® connectors. This design is based only upon parameters shown, and is for an individual building component, not a truss system. Before use, the building designer must verify the applicability of design parameters and properly incorporate this design into the overall building design. Bracing indicated is to prevent buckling of individual truss web and/or chord members only. Additional temporary and permanent bracing is always required for stability and to prevent collapse with possible personal injury and property damage. For general guidance regarding the fabrication, storage, delivery, erection and bracing of trusses and truss systems, see **ANSI/TPI1 Quality Criteria and DSB-22** available from Truss Plate Institute (www.tpinst.org) and **BCSI Building Component Safety Information** available from the Structural Building Component Association (www.sbcsccomponents.com)

**MiTek®**

16023 Swingley Ridge Rd.  
Chesterfield, MO 63017  
314.434.1200 / MiTek-US.com

Job 5449020	Truss PB01G	Truss Type Piggyback	Qty 2	Ply 1	Job Reference (optional) T41274286
----------------	----------------	-------------------------	----------	----------	---------------------------------------

Builders FirstSource (Lake City,FL), Lake City, FL - 32055,

Run: 25.40 S Apr 17 2026 Print: 25.4.0 S Apr 17 2026 MiTek Industries, Inc. Wed May 20 15:14:26  
ID:08hDRex0horjsgV?ph3e1BzEbKA-RfC?PsB70Hq3NSgPqnL8w3uTXbGKWrCDoi7J4zJC?f

Page: 1

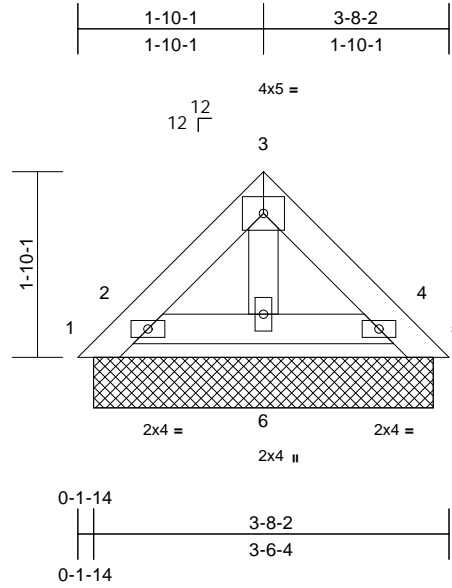

Scale = 1:22.8

Loading	(psf)	Spacing	2-0-0	CSI	DEFL	in	(loc)	l/defl	L/d	PLATES	GRIP	
TCLL (roof)	20.0	Plate Grip DOL	1.25	TC	0.03	Vert(LL)	n/a	-	n/a	999	MT20	244/190
TCDL	10.0	Lumber DOL	1.25	BC	0.05	Vert(TL)	n/a	-	n/a	999		
BCLL	0.0*	Rep Stress Incr	YES	WB	0.01	Horiz(TL)	0.00	2	n/a	n/a		
BCDL	10.0	Code	FBC2023/TPI2014	Matrix-MP							Weight: 13 lb	FT = 20%

LUMBER	
TOP CHORD	2x4 SP No.2
BOT CHORD	2x4 SP No.2
OTHERS	2x4 SP No.3
BRACING	
TOP CHORD	Structural wood sheathing directly applied.
BOT CHORD	Rigid ceiling directly applied or 6-0-0 oc bracing.
REACTIONS (size)	
1=3-4-6, 2=3-4-6, 4=3-4-6, 5=3-4-6, 6=3-4-6	
Max Horiz	1=40 (LC 8)
Max Uplift	1=18 (LC 13), 4=41 (LC 13), 5=9 (LC 20), 6=48 (LC 12)
Max Grav	1=63 (LC 20), 4=85 (LC 26), 5=13 (LC 13), 6=160 (LC 19)
FORCES (lb) - Maximum Compression/Maximum Tension	
TOP CHORD	1-2=-64/46, 2-3=-28/45, 3-4=-20/29, 4-5=-14/26
BOT CHORD	2-6=-36/71, 4-6=-36/71
WEBS	3-6=-82/34

- 6) Gable requires continuous bottom chord bearing.
  - 7) Gable studs spaced at 4-0-0 oc.
  - 8) This truss has been designed for a 10.0 psf bottom chord live load nonconcurrent with any other live loads.
  - 9) \* This truss has been designed for a live load of 20.0psf on the bottom chord in all areas where a rectangle 3-06-00 tall by 2-00-00 wide will fit between the bottom chord and any other members.
  - 10) Provide mechanical connection (by others) of truss to bearing plate capable of withstanding 41 lb uplift at joint 4, 48 lb uplift at joint 6, 18 lb uplift at joint 1, 9 lb uplift at joint 5 and 41 lb uplift at joint 4.
  - 11) See Standard Industry Piggyback Truss Connection Detail for Connection to base truss as applicable, or consult qualified building designer.
- LOAD CASE(S)** Standard

- NOTES**
- 1) Unbalanced roof live loads have been considered for this design.
  - 2) Designed to ASCE 7-22 basic load combinations for allowable stress design unless otherwise noted.
  - 3) Wind: ASCE 7-22; Vult=130mph (3-second gust) Vasd=101mph; TCDL=4.2psf; BCDL=3.0psf; h=18ft; Cat. II; Exp B; Enclosed; MWFRS (envelope) exterior (2) zone and C-C Zone3 zone;C-C for members and forces & MWFRS for reactions shown; Lumber DOL=1.60 plate grip DOL=1.60
  - 4) Truss designed for wind loads in the plane of the truss only. For studs exposed to wind (normal to the face), see Standard Industry Gable End Details as applicable, or consult qualified building designer as per ANSI/TPI 1.
  - 5) Building Designer / Project engineer responsible for verifying applied roof live load shown covers rain loading requirements specific to the use of this truss component.

This item has been digitally signed and sealed by ORegan, Philip, PE on the date indicated here. Printed copies of this document are not considered signed and sealed and the signature must be verified on any electronic copies.

Philip J. O'Regan PE No.58126  
MiTek Inc. DBA MiTek USA FL Cert 6634  
16023 Swingley Ridge Rd. Chesterfield, MO 63017  
Date:

May 22,2026

**WARNING - Verify design parameters and READ NOTES ON THIS AND INCLUDED MITEK REFERENCE PAGE MII-7473 rev. 1/2/2023 BEFORE USE.**

Design valid for use only with MiTek® connectors. This design is based only upon parameters shown, and is for an individual building component, not a truss system. Before use, the building designer must verify the applicability of design parameters and properly incorporate this design into the overall building design. Bracing indicated is to prevent buckling of individual truss web and/or chord members only. Additional temporary and permanent bracing is always required for stability and to prevent collapse with possible personal injury and property damage. For general guidance regarding the fabrication, storage, delivery, erection and bracing of trusses and truss systems, see **ANSI/TPI1 Quality Criteria and DSB-22** available from Truss Plate Institute ([www.tpinst.org](http://www.tpinst.org)) and **BCSI Building Component Safety Information** available from the Structural Building Component Association ([www.sbcsccomponents.com](http://www.sbcsccomponents.com))

**MiTek®**

16023 Swingley Ridge Rd.  
Chesterfield, MO 63017  
314.434.1200 / MiTek-US.com

Job 5449020	Truss PB02	Truss Type Piggyback	Qty 2	Ply 2	Job Reference (optional) T41274287
----------------	---------------	-------------------------	----------	----------	---------------------------------------

Builders FirstSource (Lake City,FL), Lake City, FL - 32055,

Run: 25.40 S Apr 17 2026 Print: 25.4.0 S Apr 17 2026 MiTek Industries, Inc. Wed May 20 15:14:26  
ID:ahXPb\_CBSsvZHBOcCl1B00zEbP?rFcf?PsB70Hq3NSgPqnL8w3uITXbGKWRCDoi7J4zJC?f

Page: 1

THIS TRUSS IS DESIGNED TO SUPPORT ONLY 2'-0" OF UNIFORM LOAD AS SHOWN.

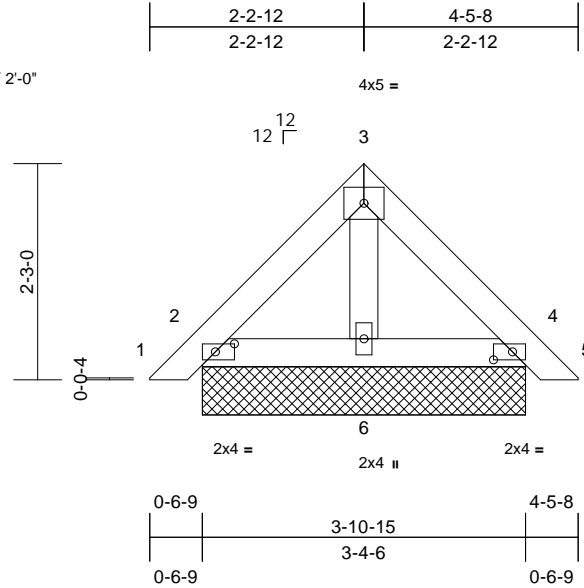

Scale = 1:24

Plate Offsets (X, Y): [2:0-2-6,0-1-0], [4:0-2-6,0-1-0]

Loading	(psf)	Spacing	2-0-0	CSI	DEFL	in	(loc)	l/defl	L/d	PLATES	GRIP	
TCLL (roof)	20.0	Plate Grip DOL	1.25	TC	0.03	Vert(LL)	n/a	-	n/a	999	MT20	244/190
TCDL	10.0	Lumber DOL	1.25	BC	0.03	Vert(CT)	n/a	-	n/a	999		
BCLL	0.0*	Rep Stress Incr	YES	WB	0.00	Horz(CT)	0.00	4	n/a	n/a		
BCDL	10.0	Code	FBC2023/TPI2014	Matrix-MP							Weight: 33 lb	FT = 20%

#### LUMBER

TOP CHORD 2x4 SP No.2  
BOT CHORD 2x4 SP No.2  
OTHERS 2x4 SP No.3

#### BRACING

TOP CHORD Structural wood sheathing directly applied.  
BOT CHORD Rigid ceiling directly applied or 10-0-0 oc bracing.

#### REACTIONS

(size) 2=3-4-6, 4=3-4-6, 6=3-4-6  
Max Horiz 2=50 (LC 11)  
Max Uplift 2=-27 (LC 13), 4=-32 (LC 13),  
6=-17 (LC 12)  
Max Grav 2=102 (LC 1), 4=102 (LC 1), 6=106 (LC 1)

#### FORCES

(lb) - Maximum Compression/Maximum Tension  
TOP CHORD 1-2=0/15, 2-3=-63/69, 3-4=-59/64, 4-5=0/15  
BOT CHORD 2-6=-20/69, 4-6=-13/69  
WEBS 3-6=-40/1

#### NOTES

- 2-ply truss to be connected together as follows:  
Top chords connected with 10d (0.131"x3") nails as follows: 2x4 - 1 row at 0-9-0 oc.  
Bottom chords connected with 10d (0.131"x3") nails as follows: 2x4 - 1 row at 0-9-0 oc.
- All loads are considered equally applied to all plies, except if noted as front (F) or back (B) face in the LOAD CASE(S) section. Ply to ply connections have been provided to distribute only loads noted as (F) or (B), unless otherwise indicated.
- Unbalanced roof live loads have been considered for this design.
- Designed to ASCE 7-22 basic load combinations for allowable stress design unless otherwise noted.

- Wind: ASCE 7-22; Vult=130mph (3-second gust) Vasd=101mph; TCDL=4.2psf; BCDL=3.0psf; h=18ft; Cat. II; Exp B; Enclosed; MWFRS (envelope) exterior (2) zone and C-C Zone3 zone;C-C for members and forces & MWFRS for reactions shown; Lumber DOL=1.60 plate grip DOL=1.60
- Truss designed for wind loads in the plane of the truss only. For studs exposed to wind (normal to the face), see Standard Industry Gable End Details as applicable, or consult qualified building designer as per ANSI/TPI 1.
- Building Designer / Project engineer responsible for verifying applied roof live load shown covers rain loading requirements specific to the use of this truss component.
- Gable requires continuous bottom chord bearing.
- Gable studs spaced at 4-0-0 oc.
- This truss has been designed for a 10.0 psf bottom chord live load nonconcurrent with any other live loads.
- \* This truss has been designed for a live load of 20.0psf on the bottom chord in all areas where a rectangle 3-06-00 tall by 2-00-00 wide will fit between the bottom chord and any other members.
- Provide mechanical connection (by others) of truss to bearing plate capable of withstanding 27 lb uplift at joint 2, 32 lb uplift at joint 4, 17 lb uplift at joint 6, 27 lb uplift at joint 2 and 32 lb uplift at joint 4.
- See Standard Industry Piggyback Truss Connection Detail for Connection to base truss as applicable, or consult qualified building designer.

LOAD CASE(S) Standard

This item has been digitally signed and sealed by ORegan, Philip, PE on the date indicated here. Printed copies of this document are not considered signed and sealed and the signature must be verified on any electronic copies.

Philip J. O'Regan PE No.58126  
MiTek Inc. DBA MiTek USA FL Cert 6634  
16023 Swingley Ridge Rd. Chesterfield, MO 63017  
Date:

May 22, 2026

#### WARNING - Verify design parameters and READ NOTES ON THIS AND INCLUDED MITEK REFERENCE PAGE MII-7473 rev. 1/2/2023 BEFORE USE.

Design valid for use only with MiTek® connectors. This design is based only upon parameters shown, and is for an individual building component, not a truss system. Before use, the building designer must verify the applicability of design parameters and properly incorporate this design into the overall building design. Bracing indicated is to prevent buckling of individual truss web and/or chord members only. Additional temporary and permanent bracing is always required for stability and to prevent collapse with possible personal injury and property damage. For general guidance regarding the fabrication, storage, delivery, erection and bracing of trusses and truss systems, see **ANSI/TPI1 Quality Criteria and DSB-22** available from Truss Plate Institute (www.tpinst.org) and **BCSI Building Component Safety Information** available from the Structural Building Component Association (www.sbcsccomponents.com)

**MiTek®**

16023 Swingley Ridge Rd.  
Chesterfield, MO 63017  
314.434.1200 / MiTek-US.com

Job 5449020	Truss PB04	Truss Type Piggyback	Qty 21	Ply 1	Job Reference (optional) T41274288
----------------	---------------	-------------------------	-----------	----------	---------------------------------------

Builders FirstSource (Lake City,FL), Lake City, FL - 32055,

Run: 25.40 S Apr 17 2026 Print: 25.4.0 S Apr 17 2026 MiTek Industries, Inc. Wed May 20 15:14:27  
ID: jcwdmv9R9fIM1\_ZwsCOSWDzEbu1-RfC?PsB70Hq3NSgPqnL8w3uTXbGKwRcDoi7J4zJC7f

Page: 1

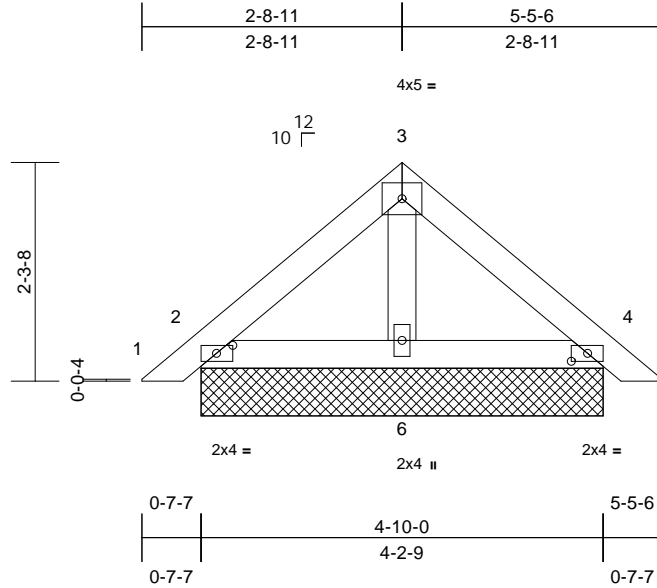

Scale = 1:24.1

Plate Offsets (X, Y): [2:0-2-1,0-1-0], [4:0-2-1,0-1-0]

Loading	(psf)	Spacing	2-0-0	CSI	DEFL	in	(loc)	l/defl	L/d	PLATES	GRIP	
TCLL (roof)	20.0	Plate Grip DOL	1.25	TC	0.07	Vert(LL)	n/a	-	n/a	999	MT20	244/190
TCDL	10.0	Lumber DOL	1.25	BC	0.07	Vert(CT)	n/a	-	n/a	999		
BCLL	0.0*	Rep Stress Incr	YES	WB	0.01	Horz(CT)	0.00	4	n/a	n/a		
BCDL	10.0	Code	FBC2023/TPI2014	Matrix-MP							Weight: 19 lb	FT = 20%

**LUMBER**

TOP CHORD 2x4 SP No.2  
BOT CHORD 2x4 SP No.2  
OTHERS 2x4 SP No.3

**BRACING**

TOP CHORD Structural wood sheathing directly applied.  
BOT CHORD Rigid ceiling directly applied or 10-0-0 oc bracing.

**REACTIONS**

(size) 2=4-2-9, 4=4-2-9, 6=4-2-9  
Max Horiz 2=-52 (LC 10)  
Max Uplift 2=-36 (LC 12), 4=-42 (LC 13),  
6=-20 (LC 12)  
Max Grav 2=123 (LC 1), 4=123 (LC 1), 6=139 (LC 1)

**FORCES**

(lb) - Maximum Compression/Maximum Tension

TOP CHORD 1-2=0/15, 2-3=-75/80, 3-4=-72/75, 4-5=0/15  
BOT CHORD 2-6=-16/57, 4-6=-9/57  
WEBS 3-6=-54/6

**NOTES**

- 1) Unbalanced roof live loads have been considered for this design.
- 2) Designed to ASCE 7-22 basic load combinations for allowable stress design unless otherwise noted.
- 3) Wind: ASCE 7-22; Vult=130mph (3-second gust) Vasd=101mph; TCDL=4.2psf; BCDL=3.0psf; h=18ft; Cat. II; Exp B; Enclosed; MWFRS (envelope) exterior (2) zone and C-C Zone3 zone;C-C for members and forces & MWFRS for reactions shown; Lumber DOL=1.60 plate grip DOL=1.60
- 4) Truss designed for wind loads in the plane of the truss only. For studs exposed to wind (normal to the face), see Standard Industry Gable End Details as applicable, or consult qualified building designer as per ANSI/TPI 1.
- 5) Building Designer / Project engineer responsible for verifying applied roof live load shown covers rain loading requirements specific to the use of this truss component.
- 6) Gable requires continuous bottom chord bearing.

- 7) Gable studs spaced at 4-0-0 oc.
- 8) This truss has been designed for a 10.0 psf bottom chord live load nonconcurrent with any other live loads.
- 9) \* This truss has been designed for a live load of 20.0psf on the bottom chord in all areas where a rectangle 3-06-00 tall by 2-00-00 wide will fit between the bottom chord and any other members.
- 10) Provide mechanical connection (by others) of truss to bearing plate capable of withstanding 36 lb uplift at joint 2, 42 lb uplift at joint 4, 20 lb uplift at joint 6, 36 lb uplift at joint 2 and 42 lb uplift at joint 4.
- 11) See Standard Industry Piggyback Truss Connection Detail for Connection to base truss as applicable, or consult qualified building designer.

**LOAD CASE(S)** Standard

This item has been digitally signed and sealed by ORegan, Philip, PE on the date indicated here. Printed copies of this document are not considered signed and sealed and the signature must be verified on any electronic copies.

Philip J. O'Regan PE No.58126  
MiTek Inc. DBA MiTek USA FL Cert 6634  
16023 Swingley Ridge Rd. Chesterfield, MO 63017  
Date:

May 22,2026

**WARNING - Verify design parameters and READ NOTES ON THIS AND INCLUDED MITEK REFERENCE PAGE MII-7473 rev. 1/2/2023 BEFORE USE.**

Design valid for use only with MiTek® connectors. This design is based only upon parameters shown, and is for an individual building component, not a truss system. Before use, the building designer must verify the applicability of design parameters and properly incorporate this design into the overall building design. Bracing indicated is to prevent buckling of individual truss web and/or chord members only. Additional temporary and permanent bracing is always required for stability and to prevent collapse with possible personal injury and property damage. For general guidance regarding the fabrication, storage, delivery, erection and bracing of trusses and truss systems, see **ANSI/TPI1 Quality Criteria and DSB-22** available from Truss Plate Institute (www.tpinst.org) and **BCSI Building Component Safety Information** available from the Structural Building Component Association (www.sbcsccomponents.com)

**MiTek®**

16023 Swingley Ridge Rd.  
Chesterfield, MO 63017  
314.434.1200 / MiTek-US.com

Job 5449020	Truss PB04G	Truss Type Piggyback	Qty 2	Ply 1	Job Reference (optional) T41274289
----------------	----------------	-------------------------	----------	----------	---------------------------------------

Builders FirstSource (Lake City,FL), Lake City, FL - 32055,

Run: 25.40 S Apr 17 2026 Print: 25.4.0 S Apr 17 2026 MiTek Industries, Inc. Wed May 20 15:14:27  
ID:LzWtjGAhG36QsJA8eEGiLpzEbjh-RfC?PsB70Hq3NSgPqnL8w3uITXbGKwRCDoi7J4zJC7f

Page: 1

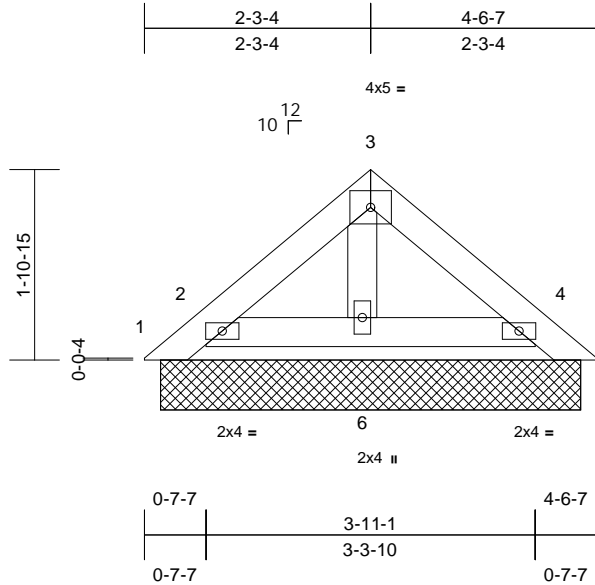

Scale = 1:23.1

Loading	(psf)	Spacing	2-0-0	CSI	DEFL	in	(loc)	l/defl	L/d	PLATES	GRIP	
TCLL (roof)	20.0	Plate Grip DOL	1.25	TC	0.04	Vert(LL)	n/a	-	n/a	999	MT20	244/190
TCDL	10.0	Lumber DOL	1.25	BC	0.04	Vert(TL)	n/a	-	n/a	999		
BCLL	0.0*	Rep Stress Incr	YES	WB	0.00	Horiz(TL)	0.00	4	n/a	n/a		
BCDL	10.0	Code	FBC2023/TPI2014	Matrix-MP							Weight: 15 lb	FT = 20%

**LUMBER**

TOP CHORD 2x4 SP No.2  
BOT CHORD 2x4 SP No.2  
OTHERS 2x4 SP No.3

**BRACING**

TOP CHORD Structural wood sheathing directly applied.  
BOT CHORD Rigid ceiling directly applied or 10-0-0 oc bracing.

**REACTIONS**

(size) 1=4-2-9, 2=4-2-9, 4=4-2-9, 5=4-2-9, 6=4-2-9  
Max Horiz 1=42 (LC 11)  
Max Uplift 1=-48 (LC 10), 2=-71 (LC 12), 4=-55 (LC 13), 5=-25 (LC 20), 6=-7 (LC 12)  
Max Grav 1=41 (LC 9), 2=182 (LC 19), 4=162 (LC 1), 5=19 (LC 13), 6=74 (LC 3)

**FORCES**

(lb) - Maximum Compression/Maximum Tension

TOP CHORD 1-2=-58/75, 2-3=-83/59, 3-4=-83/59, 4-5=-23/36  
BOT CHORD 2-6=-10/53, 4-6=-10/53

**NOTES**

- 1) Unbalanced roof live loads have been considered for this design.
- 2) Designed to ASCE 7-22 basic load combinations for allowable stress design unless otherwise noted.
- 3) Wind: ASCE 7-22; Vult=130mph (3-second gust) Vasd=101mph; TCDL=4.2psf; BCDL=3.0psf; h=18ft; Cat. II; Exp B; Enclosed; MWFRS (envelope) exterior (2) zone and C-C Zone3 zone;C-C for members and forces & MWFRS for reactions shown; Lumber DOL=1.60 plate grip DOL=1.60
- 4) Truss designed for wind loads in the plane of the truss only. For studs exposed to wind (normal to the face), see Standard Industry Gable End Details as applicable, or consult qualified building designer as per ANSI/TPI 1.
- 5) Building Designer / Project engineer responsible for verifying applied roof live load shown covers rain loading requirements specific to the use of this truss component.

- 6) Gable requires continuous bottom chord bearing.
- 7) Gable studs spaced at 1-4-0 oc.
- 8) This truss has been designed for a 10.0 psf bottom chord live load nonconcurrent with any other live loads.
- 9) \* This truss has been designed for a live load of 20.0psf on the bottom chord in all areas where a rectangle 3-06-00 tall by 2-00-00 wide will fit between the bottom chord and any other members.
- 10) Provide mechanical connection (by others) of truss to bearing plate capable of withstanding 71 lb uplift at joint 2, 55 lb uplift at joint 4, 7 lb uplift at joint 6, 48 lb uplift at joint 1, 25 lb uplift at joint 5, 71 lb uplift at joint 2 and 55 lb uplift at joint 4.
- 11) See Standard Industry Piggyback Truss Connection Detail for Connection to base truss as applicable, or consult qualified building designer.

**LOAD CASE(S)** Standard

This item has been digitally signed and sealed by ORegan, Philip, PE on the date indicated here. Printed copies of this document are not considered signed and sealed and the signature must be verified on any electronic copies.

Philip J. O'Regan PE No.58126  
MiTek Inc. DBA MiTek USA FL Cert 6634  
16023 Swingley Ridge Rd. Chesterfield, MO 63017  
Date:

May 22,2026

**WARNING - Verify design parameters and READ NOTES ON THIS AND INCLUDED MITEK REFERENCE PAGE MII-7473 rev. 1/2/2023 BEFORE USE.**

Design valid for use only with MiTek® connectors. This design is based only upon parameters shown, and is for an individual building component, not a truss system. Before use, the building designer must verify the applicability of design parameters and properly incorporate this design into the overall building design. Bracing indicated is to prevent buckling of individual truss web and/or chord members only. Additional temporary and permanent bracing is always required for stability and to prevent collapse with possible personal injury and property damage. For general guidance regarding the fabrication, storage, delivery, erection and bracing of trusses and truss systems, see **ANSI/TPI1 Quality Criteria and DSB-22** available from Truss Plate Institute (www.tpinst.org) and **BCSI Building Component Safety Information** available from the Structural Building Component Association (www.sbcsccomponents.com)

**MiTek®**

16023 Swingley Ridge Rd.  
Chesterfield, MO 63017  
314.434.1200 / MiTek-US.com

Job 5449020	Truss T01	Truss Type Attic	Qty 4	Ply 1	Job Reference (optional) T41274290
----------------	--------------	---------------------	----------	----------	---------------------------------------

Builders FirstSource (Lake City,FL), Lake City, FL - 32055,

Run: 25.40 S Apr 17 2026 Print: 25.4.0 S Apr 17 2026 MiTek Industries, Inc. Wed May 20 15:14:27  
ID:D7VjVjQPomuhjkTjyVV5vzEazb-RfC?PsB70Hq3NSgPqnL8w3ulTXbGKWRcDoi7J4zJC?f

Page: 1

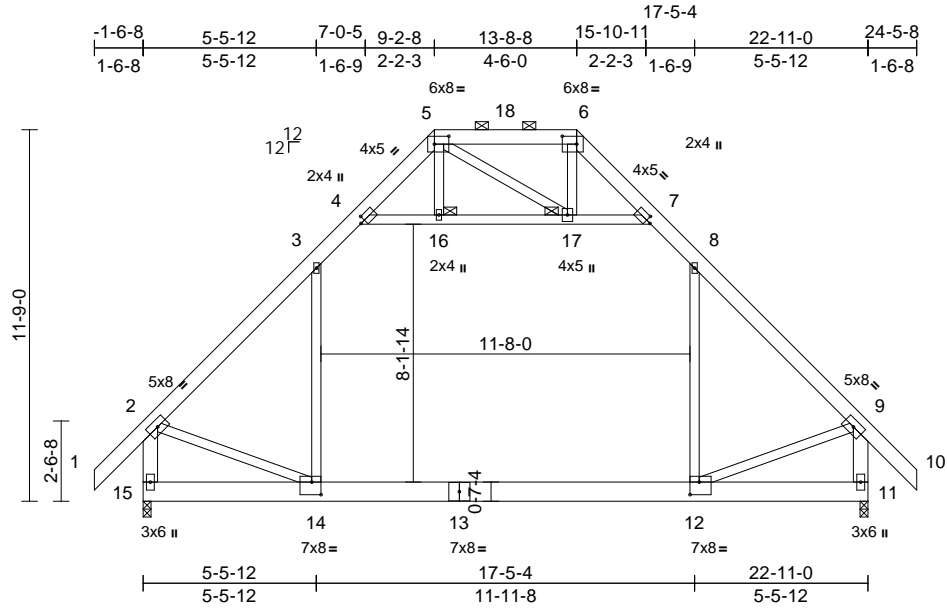

Scale = 1:72.8

Plate Offsets (X, Y): [4:0-1-13,0-2-0], [5:0-5-8,0-3-0], [6:0-5-8,0-3-0], [7:0-1-13,0-2-0], [12:0-3-8,0-4-12], [14:0-3-8,0-4-12]

Loading	(psf)	Spacing	2-0-0	CSI	DEFL	in	(loc)	l/defl	L/d	PLATES	GRIP	
TCLL (roof)	20.0	Plate Grip DOL	1.25	TC	0.57	Vert(LL)	-0.20	12-14	>999	240	MT20	244/190
TCDL	10.0	Lumber DOL	1.25	BC	0.42	Vert(CT)	-0.32	12-14	>835	180		
BCLL	0.0*	Rep Stress Incr	YES	WB	0.41	Horz(CT)	0.01	11	n/a	n/a		
BCDL	10.0	Code	FBC2023/TPI2014	Matrix-MS		Attic	-0.16	12-14	>878	360	Weight: 225 lb	FT = 20%

**LUMBER**  
TOP CHORD 2x6 SP No.2  
BOT CHORD 2x8 SP 2400F 2.0E  
WEBS 2x4 SP No.3 \*Except\* 15-2,11-9:2x6 SP No.2

**BRACING**  
TOP CHORD Structural wood sheathing directly applied, except end verticals, and 2-0-0 oc purlins: 5-6.  
BOT CHORD Rigid ceiling directly applied or 10-0-0 oc bracing.

**JOINTS**  
1 Brace at Jt(s): 16, 17

**REACTIONS** (size) 11=0-3-0, 15=0-3-0  
Max Horiz 15=-345 (LC 10)  
Max Uplift 11=-45 (LC 13), 15=-45 (LC 12)  
Max Grav 11=1487 (LC 2), 15=1487 (LC 2)

**FORCES** (lb) - Maximum Compression/Maximum Tension  
TOP CHORD 1-2=0/75, 2-3=-1508/59, 3-4=-909/139, 4-5=-346/94, 5-6=-169/131, 6-7=-342/95, 7-8=-909/139, 8-9=-1507/59, 9-10=0/75, 2-15=-1615/47, 9-11=-1615/47  
BOT CHORD 14-15=-339/411, 12-14=0/1018, 11-12=-80/109  
WEBS 3-14=0/715, 8-12=0/714, 4-16=-951/131, 16-17=-947/132, 7-17=-958/132, 2-14=-43/1045, 9-12=-46/1048, 5-16=0/58, 6-17=-24/97, 5-17=-98/92

**NOTES**  
1) Unbalanced roof live loads have been considered for this design.  
2) Designed to ASCE 7-22 basic load combinations for allowable stress design unless otherwise noted.

- Wind: ASCE 7-22; Vult=130mph (3-second gust) Vasd=101mph; TC DL=4.2psf; BCDL=3.0psf; h=18ft; Cat. II; Exp B; Enclosed; MWFRS (envelope) exterior (2) zone and C-C Zone1 -1-6-0 to 9-3-0, Zone3 9-3-0 to 13-9-0, Zone1 13-9-0 to 24-6-0 zone; end vertical left and right exposed; C-C for members and forces & MWFRS for reactions shown; Lumber DOL=1.60 plate grip DOL=1.60
- Building Designer / Project engineer responsible for verifying applied roof live load shown covers rain loading requirements specific to the use of this truss component.
- Provide adequate drainage to prevent water ponding.
- This truss has been designed for a 10.0 psf bottom chord live load nonconcurrent with any other live loads.
- \* This truss has been designed for a live load of 20.0psf on the bottom chord in all areas where a rectangle 3-06-00 tall by 2-00-00 wide will fit between the bottom chord and any other members.
- Ceiling dead load (5.0 psf) on member(s). 3-4, 7-8, 4-16, 16-17, 7-17; Wall dead load (5.0psf) on member(s).3-14, 8-12
- Bottom chord live load (40.0 psf) and additional bottom chord dead load (10.0 psf) applied only to room. 12-14
- Provide mechanical connection (by others) of truss to bearing plate capable of withstanding 45 lb uplift at joint 15 and 45 lb uplift at joint 11.
- Graphical purlin representation does not depict the size or the orientation of the purlin along the top and/or bottom chord.
- Attic room checked for L/360 deflection.

**LOAD CASE(S)** Standard

This item has been digitally signed and sealed by ORegan, Philip, PE on the date indicated here. Printed copies of this document are not considered signed and sealed and the signature must be verified on any electronic copies.

Philip J. O'Regan PE No.58126  
MiTek Inc. DBA MiTek USA FL Cert 6634  
16023 Swingley Ridge Rd. Chesterfield, MO 63017  
Date:

May 22, 2026

**WARNING - Verify design parameters and READ NOTES ON THIS AND INCLUDED MITEK REFERENCE PAGE MII-7473 rev. 1/2/2023 BEFORE USE.**

Design valid for use only with MiTek® connectors. This design is based only upon parameters shown, and is for an individual building component, not a truss system. Before use, the building designer must verify the applicability of the design parameters and properly incorporate this design into the overall building design. Bracing indicated is to prevent buckling of individual truss web and/or chord members only. Additional temporary and permanent bracing is always required for stability and to prevent collapse with possible personal injury and property damage. For general guidance regarding the fabrication, storage, delivery, erection and bracing of trusses and truss systems, see **ANSI/TPI1 Quality Criteria and DSB-22** available from Truss Plate Institute (www.tpinst.org) and **BCSI Building Component Safety Information** available from the Structural Building Component Association (www.sbcsccomponents.com)

**MiTek®**  
16023 Swingley Ridge Rd.  
Chesterfield, MO 63017  
314.434.1200 / MiTek-US.com

Job 5449020	Truss T01G	Truss Type Attic Girder	Qty 1	Ply 1	Job Reference (optional) T41274291
----------------	---------------	----------------------------	----------	----------	---------------------------------------

Builders FirstSource (Lake City,FL), Lake City, FL - 32055,

Run: 25.40 S Apr 17 2026 Print: 25.4.0 S Apr 17 2026 MiTek Industries, Inc. Wed May 20 15:14:27  
ID:UD38M1yh5Hl3rYxaSTYgPgZEai7-RfC?PsB70Hq3NSgPqnL8w3uITxBGKWrCDoi7J4zJC7f

Page: 1

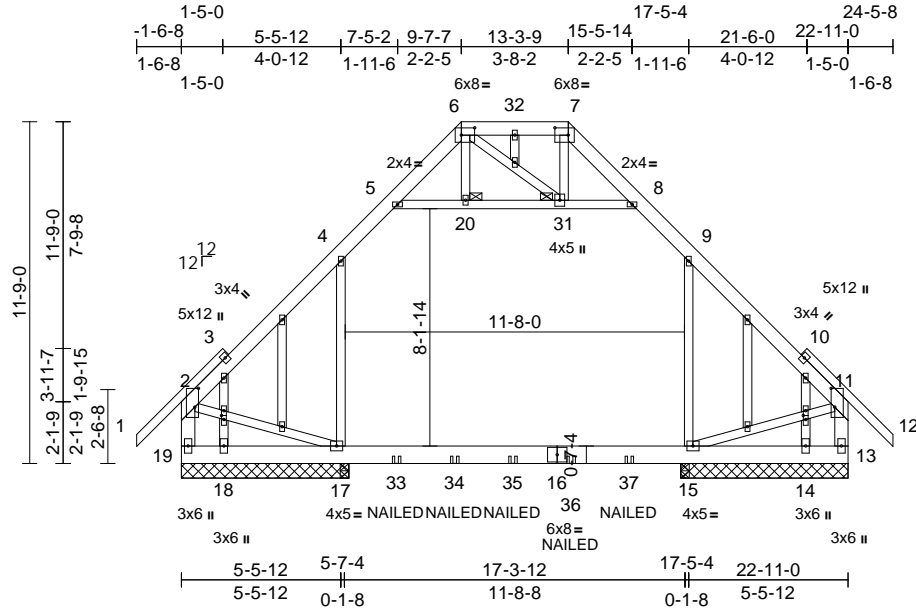

Scale = 1:79.2

Plate Offsets (X, Y): [2:0-7-12,0-1-8], [6:0-5-8,0-3-0], [7:0-5-8,0-3-0], [11:0-7-12,0-1-8], [25:0-1-10,0-1-0], [30:0-1-10,0-1-0]

Loading	(psf)	Spacing	2-0-0	CSI	DEFL	in (loc)	l/defl	L/d	PLATES	GRIP		
TCLL (roof)	20.0	Plate Grip DOL	1.25	TC	0.22	Vert(LL)	-0.12	15-17	>999	240	MT20	244/190
TCDL	10.0	Lumber DOL	1.25	BC	0.39	Vert(CT)	-0.19	15-17	>758	180		
BCLL	0.0*	Rep Stress Incr	NO	WB	0.13	Horz(CT)	0.00	13	n/a	n/a		
BCDL	10.0	Code	FBC2023/TPI2014	Matrix-MS		Attic	-0.12	15-17	>999	360	Weight: 243 lb	FT = 20%

**LUMBER**  
TOP CHORD 2x6 SP No.2 \*Except\* 1-3,10-12:2x4 SP No.2  
BOT CHORD 2x8 SP 2400F 2.0E  
WEBS 2x4 SP No.3 \*Except\* 19-2,13-11:2x6 SP No.2

OTHERS 2x4 SP No.3

**BRACING**  
TOP CHORD Structural wood sheathing directly applied, except end verticals.  
BOT CHORD Rigid ceiling directly applied or 10-0-0 oc bracing.

JOINTS 1 Brace at Jt(s):  
20, 31

**REACTIONS** (size)  
13=5-9-0, 14=5-9-0, 15=5-9-0,  
17=5-9-0, 18=5-9-0, 19=5-9-0  
Max Horiz 19=336 (LC 6)  
Max Uplift 13=57 (LC 5), 14=762 (LC 14),  
15=204 (LC 9), 17=207 (LC 8),  
18=762 (LC 14), 19=69 (LC 4)  
Max Grav 13=889 (LC 16), 14=39 (LC 5),  
15=1503 (LC 17), 17=1508 (LC 16),  
18=32 (LC 4), 19=899 (LC 17)

**FORCES** (lb) - Maximum Compression/Maximum Tension  
TOP CHORD 1-2=0/66, 2-4=450/126, 4-5=475/115,  
5-6=367/74, 6-7=240/98, 7-8=366/73,  
8-9=475/114, 9-11=450/119, 11-12=0/66,  
2-19=576/86, 11-13=576/81  
BOT CHORD 18-19=296/328, 17-18=296/328,  
15-17=110/307, 14-15=44/58, 13-14=44/58  
WEBS 4-17=452/286, 9-15=447/284, 5-20=58/92,  
20-31=56/93, 8-31=52/92, 2-17=113/309,  
11-15=115/310, 6-20=0/35, 7-31=12/67,  
6-31=54/54

**NOTES**  
1) Unbalanced roof live loads have been considered for this design.

- Designed to ASCE 7-22 basic load combinations for allowable stress design unless otherwise noted.
- Wind: ASCE 7-22; Vult=130mph (3-second gust) Vasd=101mph; TC DL=4.2psf; BCDL=3.0psf; h=18ft; Cat. II; Exp B; Enclosed; MWFRS (envelope) exterior (2) zone; end vertical left and right exposed; Lumber DOL=1.60 plate grip DOL=1.60
- Truss designed for wind loads in the plane of the truss only. For studs exposed to wind (normal to the face), see Standard Industry Gable End Details as applicable, or consult qualified building designer as per ANSI/TPI 1.
- Building Designer / Project engineer responsible for verifying applied roof live load shown covers rain loading requirements specific to the use of this truss component.
- Provide adequate drainage to prevent water ponding.
- All plates are 2x4 (||) MT20 unless otherwise indicated.
- Gable studs spaced at 2-0-0 oc.
- This truss has been designed for a 10.0 psf bottom chord live load nonconcurrent with any other live loads.
- \* This truss has been designed for a live load of 20.0psf on the bottom chord in all areas where a rectangle 3-06-00 tall by 2-00-00 wide will fit between the bottom chord and any other members.
- Ceiling dead load (5.0 psf) on member(s). 4-5, 8-9, 5-20, 20-31, 8-31; Wall dead load (5.0psf) on member(s).4-17, 9-15
- Bottom chord live load (40.0 psf) and additional bottom chord dead load (10.0 psf) applied only to room. 15-17
- Provide mechanical connection (by others) of truss to bearing plate capable of withstanding 207 lb uplift at joint 17, 204 lb uplift at joint 15, 69 lb uplift at joint 19, 57 lb uplift at joint 13, 762 lb uplift at joint 18 and 762 lb uplift at joint 14.
- "NAILED" indicates 3-10d (0.148"x3") or 3-12d (0.148"x3.25") toe-nails per NDS guidelines.
- Attic room checked for L/360 deflection.
- In the LOAD CASE(S) section, loads applied to the face of the truss are noted as front (F) or back (B).

LOAD CASE(S) Standard

- Dead + Roof Live (balanced): Lumber Increase=1.25, Plate Increase=1.25  
Uniform Loads (lb/ft)  
Vert: 1-2=-60, 2-4=-60, 4-5=-70, 5-6=-60, 6-7=-60, 7-8=-60, 8-9=-70, 9-11=-60, 11-12=-60, 5-20=-10, 20-31=-10, 8-31=-10, 17-19=-20, 15-17=-40, 13-15=-20  
Drag: 4-17=-10, 9-15=-10  
Concentrated Loads (lb)  
Vert: 33=-18 (F), 34=-18 (F), 35=-18 (F), 36=-18 (F), 37=-18 (F)

This item has been digitally signed and sealed by O'Regan, Philip, PE on the date indicated here. Printed copies of this document are not considered signed and sealed and the signature must be verified on any electronic copies.

Philip J. O'Regan PE No.58126  
MiTek Inc. DBA MiTek USA FL Cert 6634  
16023 Swingley Ridge Rd. Chesterfield, MO 63017  
Date:

May 22, 2026

**WARNING - Verify design parameters and READ NOTES ON THIS AND INCLUDED MITEK REFERENCE PAGE MII-7473 rev. 1/2/2023 BEFORE USE.**

Design valid for use only with MiTek® connectors. This design is based only upon parameters shown, and is for an individual building component, not a truss system. Before use, the building designer must verify the applicability of the design parameters and properly incorporate this design into the overall building design. Bracing indicated is to prevent buckling of individual truss web and/or chord members only. Additional temporary and permanent bracing is always required for stability and to prevent collapse with possible personal injury and property damage. For general guidance regarding the fabrication, storage, delivery, erection and bracing of trusses and truss systems, see **ANSI/TPI1 Quality Criteria and DSB-22** available from Truss Plate Institute (www.tpinst.org) and **BCSI Building Component Safety Information** available from the Structural Building Component Association (www.sbcsccomponents.com)

**MiTek®**

16023 Swingley Ridge Rd.  
Chesterfield, MO 63017  
314.434.1200 / MiTek-US.com



Job 5449020	Truss T03	Truss Type Attic Girder	Qty 1	Ply 2	Job Reference (optional) T41274293
----------------	--------------	----------------------------	----------	----------	---------------------------------------

Builders FirstSource (Lake City,FL), Lake City, FL - 32055,

Run: 25.40 S Apr 17 2026 Print: 25.4.0 S Apr 17 2026 MiTek Industries, Inc. Wed May 20 15:14:28  
 ID:zarx6tcdqN0dnbwzKWoTZzEag\_-RfC?PsB70Hq3NSgPqnL8w3uITxBGKWrCDoi7J4zJC7f

Page: 1

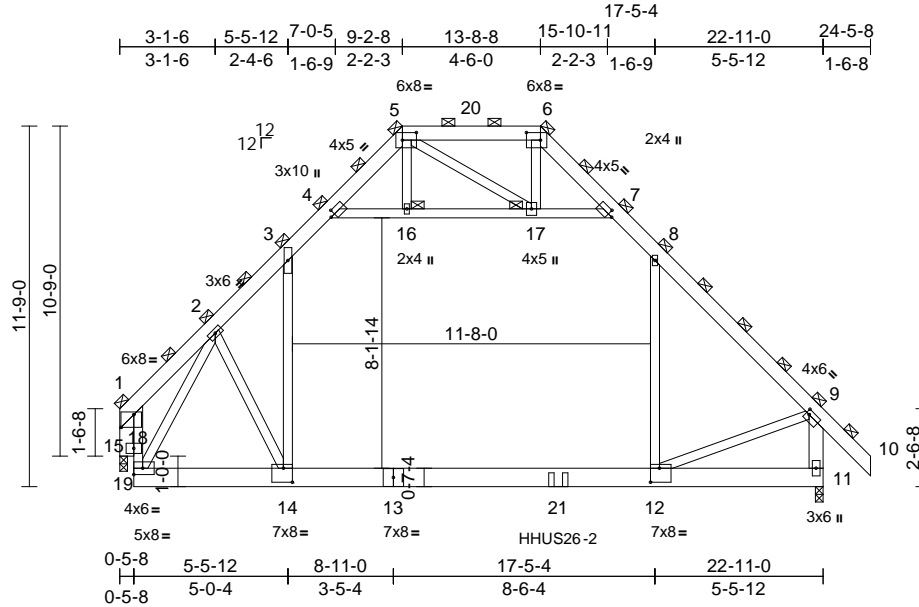

Scale = 1:75.1  
 Plate Offsets (X, Y): [1:0-5-0,Edge], [4:0-1-13,0-2-0], [5:0-5-8,0-3-0], [6:0-5-8,0-3-0], [7:0-1-13,0-2-0], [9:0-1-4,0-1-12], [12:0-3-8,0-5-8], [14:0-3-8,0-5-8]

Loading	(psf)	Spacing	5-0-0	CSI	DEFL	in (loc)	l/defl	L/d	PLATES	GRIP
TCLL (roof)	20.0	Plate Grip DOL	1.25	TC	0.86	Vert(LL)	-0.27	12-14	>995	240
TCDL	10.0	Lumber DOL	1.25	BC	0.63	Vert(CT)	-0.44	12-14	>612	180
BCLL	0.0*	Rep Stress Incr	NO	WB	0.55	Horz(CT)	0.03	11	n/a	n/a
BCDL	10.0	Code	FBC2023/TPI2014	Matrix-MS	Attic	-0.22	12-14	>659	360	Weight: 456 lb FT = 20%

**LUMBER**  
 TOP CHORD 2x6 SP No.2  
 BOT CHORD 2x8 SP 2400F 2.0E  
 WEBS 2x4 SP No.3 \*Except\* 15-1:2x4 SP No.2,  
 11-9:2x6 SP No.2  
 OTHERS 2x6 SP No.2

**BRACING**  
 TOP CHORD 2-0-0 oc purlins, except end verticals  
 (Switched from sheeted: Spacing > 2-0-0).  
 BOT CHORD Rigid ceiling directly applied or 10-0-0 oc  
 bracing.

**JOINTS**  
 1 Brace at Jt(s): 1,  
 5, 6, 9, 16, 17

**REACTIONS** (size) 11=0-3-0, 19=0-3-0  
 Max Horiz 19=740 (LC 4)  
 Max Uplift 11=374 (LC 9), 19=143 (LC 8)  
 Max Grav 11=4078 (LC 17), 19=3595 (LC 2)

**FORCES** (lb) - Maximum Compression/Maximum  
 Tension  
 TOP CHORD 1-2=-1381/283, 2-3=-4191/464,  
 3-4=-2436/484, 4-5=-856/284, 5-6=-387/329,  
 6-7=-844/286, 7-8=-2451/457, 8-9=-4174/402,  
 9-10=0/188, 15-18=0/2660, 1-18=0/2660,  
 9-11=-4442/371  
 BOT CHORD 14-15=-258/2674, 12-14=-110/2797,  
 11-12=-225/258  
 WEBS 3-14=-183/2322, 8-12=-178/1974,  
 4-16=-2736/562, 16-17=-2727/565,  
 7-17=-2653/493, 9-12=-215/2840,  
 2-14=-256/822, 2-15=-3478/132, 5-16=0/150,  
 6-17=-69/247, 5-17=-272/258,  
 1-19=-3738/149

- 2-ply truss to be connected together with 10d (0.131"x3") nails as follows:  
 Top chords connected as follows: 2x6 - 2 rows staggered at 0-9-0 oc, 2x4 - 1 row at 0-9-0 oc.  
 Bottom chords connected as follows: 2x8 - 2 rows staggered at 0-9-0 oc.  
 Web connected as follows: 2x4 - 1 row at 0-9-0 oc.  
 All loads are considered equally applied to all plies, except if noted as front (F) or back (B) face in the LOAD CASE(S) section. Ply to ply connections have been provided to distribute only loads noted as (F) or (B), unless otherwise indicated.
- Unbalanced roof live loads have been considered for this design.
- Designed to ASCE 7-22 basic load combinations for allowable stress design unless otherwise noted.
- Wind: ASCE 7-22; Vult=130mph (3-second gust) Vasd=101mph; TCDL=4.2psf; BCDL=3.0psf; h=18ft; Cat. II; Exp B; Enclosed; MWFRS (envelope) exterior (2) zone; end vertical right exposed; Lumber DOL=1.60 plate grip DOL=1.60
- Building Designer / Project engineer responsible for verifying applied roof live load shown covers rain loading requirements specific to the use of this truss component.
- Provide adequate drainage to prevent water ponding.
- This truss has been designed for a 10.0 psf bottom chord live load nonconcurrent with any other live loads.
- \* This truss has been designed for a live load of 20.0psf on the bottom chord in all areas where a rectangle 3-06-00 tall by 2-00-00 wide will fit between the bottom chord and any other members.
- Ceiling dead load (5.0 psf) on member(s). 3-4, 7-8, 4-16, 16-17, 7-17; Wall dead load (5.0psf) on member(s).3-14, 8-12
- Bottom chord live load (40.0 psf) and additional bottom chord dead load (10.0 psf) applied only to room. 12-14
- Bearing at joint(s) 19 considers parallel to grain value using ANSI/TPI 1 angle to grain formula. Building designer should verify capacity of bearing surface.

- Provide mechanical connection (by others) of truss to bearing plate at joint(s) 11, 19.
  - Provide mechanical connection (by others) of truss to bearing plate capable of withstanding 374 lb uplift at joint 11 and 143 lb uplift at joint 19.
  - Use Simpson Strong-Tie HHUS26-2 (14-10d Girder, 6-10d Truss, Single Ply Girder) or equivalent at 14-4-0 from the left end to connect truss(es) to back face of bottom chord.
  - Fill all nail holes where hanger is in contact with lumber.
  - Attic room checked for L/360 deflection.
- LOAD CASE(S)** Standard
- Dead + Roof Live (balanced): Lumber Increase=1.25, Plate Increase=1.25  
 Uniform Loads (lb/ft)  
 Vert: 1-3=-150, 3-4=-175, 4-5=-150, 5-6=-150,  
 6-7=-150, 7-8=-175, 8-9=-150, 9-10=-150, 14-15=-50,  
 12-14=-100, 11-12=-50, 4-16=-25, 16-17=-25,  
 7-17=-25  
 Drag: 3-14=-25, 8-12=-25  
 Concentrated Loads (lb)  
 Vert: 21=-460 (B)

This item has been digitally signed and sealed by O'Regan, Philip, PE on the date indicated here. Printed copies of this document are not considered signed and sealed and the signature must be verified on any electronic copies.

Philip J. O'Regan PE No.58126  
 MiTek Inc. DBA MiTek USA FL Cert 6634  
 16023 Swingley Ridge Rd. Chesterfield, MO 63017  
 Date:

May 22, 2026

<p><b>WARNING - Verify design parameters and READ NOTES ON THIS AND INCLUDED MITEK REFERENCE PAGE MII-7473 rev. 1/2/2023 BEFORE USE.</b></p> <p>Design valid for use only with MiTek® connectors. This design is based only upon parameters shown, and is for an individual building component, not a truss system. Before use, the building designer must verify the applicability of design parameters and properly incorporate this design into the overall building design. Bracing indicated is to prevent buckling of individual truss web and/or chord members only. Additional temporary and permanent bracing is always required for stability and to prevent collapse with possible personal injury and property damage. For general guidance regarding the fabrication, storage, delivery, erection and bracing of trusses and truss systems, see <b>ANSI/TPI1 Quality Criteria and DSB-22</b> available from Truss Plate Institute (www.tpinst.org) and <b>BCSI Building Component Safety Information</b> available from the Structural Building Component Association (www.sbcsccomponents.com)</p>	 <p>16023 Swingley Ridge Rd.        Chesterfield, MO 63017        314.434.1200 / MiTek-US.com</p>
------------------------------------------------------------------------------------------------------------------------------------------------------------------------------------------------------------------------------------------------------------------------------------------------------------------------------------------------------------------------------------------------------------------------------------------------------------------------------------------------------------------------------------------------------------------------------------------------------------------------------------------------------------------------------------------------------------------------------------------------------------------------------------------------------------------------------------------------------------------------------------------------------------------------------------------------------------------------------------------------------------------------------------------------------------------------------------------------------------------	------------------------------------------------------------------------------------------------------------------------------------------------------------------------------------------------

Job 5449020	Truss T04	Truss Type Monopitch Girder	Qty 1	Ply 1	Job Reference (optional) T41274294
----------------	--------------	--------------------------------	----------	----------	---------------------------------------

Builders FirstSource (Lake City,FL), Lake City, FL - 32055,

Run: 25.40 S Apr 17 2026 Print: 25.4.0 S Apr 17 2026 MiTek Industries, Inc. Wed May 20 15:14:28  
ID:9g4DYJkUUKzyhOiOxwwSBzEcpE-RfC?PsB70Hq3NSgPqnL8w3uITXbGKWrCDoi7J4zJC?f

Page: 1

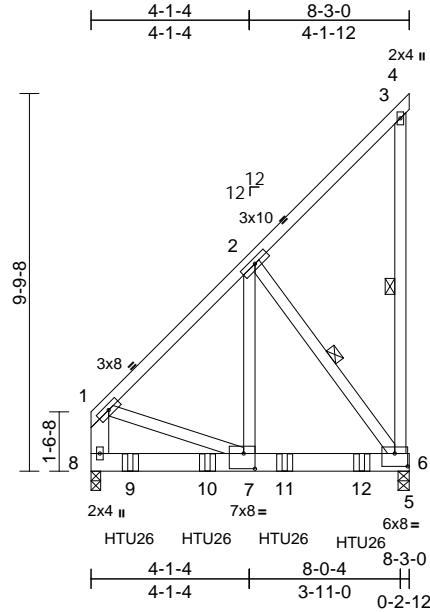

Scale = 1:59.7

Plate Offsets (X, Y): [6:0-4-0,0-4-0], [7:0-3-8,0-4-12]

Loading	(psf)	Spacing	2-0-0	CSI	DEFL	in	(loc)	l/defl	L/d	PLATES	GRIP	
TCLL (roof)	20.0	Plate Grip DOL	1.25	TC	0.25	Vert(LL)	-0.03	6-7	>999	240	MT20	244/190
TCDL	10.0	Lumber DOL	1.25	BC	0.92	Vert(CT)	-0.06	6-7	>999	180		
BCLL	0.0*	Rep Stress Incr	NO	WB	0.68	Horz(CT)	0.00	6	n/a	n/a		
BCDL	10.0	Code	FBC2023/TPI2014	Matrix-MP							Weight: 75 lb	FT = 20%

**LUMBER**  
TOP CHORD 2x4 SP No.2  
BOT CHORD 2x6 SP No.2  
WEBS 2x4 SP No.3 \*Except\* 8-1:2x6 SP No.2

**BRACING**  
TOP CHORD Structural wood sheathing directly applied, except end verticals.  
BOT CHORD Rigid ceiling directly applied or 9-11-1 oc bracing.  
WEBS 1 Row at midpt 3-6, 2-6

**REACTIONS** (size) 6=0-3-8, 8=0-3-0  
Max Horiz 8=291 (LC 8)  
Max Uplift 6=-682 (LC 8), 8=-346 (LC 4)  
Max Grav 6=1911 (LC 1), 8=1990 (LC 1)

**FORCES** (lb) - Maximum Compression/Maximum Tension  
TOP CHORD 1-2=-1296/232, 2-3=-136/64, 3-4=-3/0, 3-6=-114/116, 1-8=-1277/196  
BOT CHORD 7-8=-300/128, 6-7=-326/883, 5-6=0/0  
WEBS 2-7=-427/1798, 2-6=-1470/543, 1-7=-178/934

- NOTES**
- 1) Unbalanced roof live loads have been considered for this design.
  - 2) Designed to ASCE 7-22 basic load combinations for allowable stress design unless otherwise noted.
  - 3) Wind: ASCE 7-22; Vult=130mph (3-second gust) Vasd=101mph; TCDL=4.2psf; BCDL=3.0psf; h=18ft; Cat. II; Exp B; Enclosed; MWFRS (envelope) exterior (2) zone; end vertical left exposed; Lumber DOL=1.60 plate grip DOL=1.60
  - 4) Building Designer / Project engineer responsible for verifying applied roof live load shown covers rain loading requirements specific to the use of this truss component.
  - 5) This truss has been designed for a 10.0 psf bottom chord live load nonconcurrent with any other live loads.

- 6) \* This truss has been designed for a live load of 20.0psf on the bottom chord in all areas where a rectangle 3-06-00 tall by 2-00-00 wide will fit between the bottom chord and any other members.
  - 7) Provide mechanical connection (by others) of truss to bearing plate capable of withstanding 346 lb uplift at joint 8 and 682 lb uplift at joint 6.
  - 8) Use Simpson Strong-Tie HTU26 (20-16d Girder, 11-10dx1 1/2 Truss, Single Ply Girder) or equivalent spaced at 2-0-0 oc max. starting at 1-0-12 from the left end to 7-0-12 to connect truss(es) to back face of bottom chord.
  - 9) Fill all nail holes where hanger is in contact with lumber.
  - 10) In the LOAD CASE(S) section, loads applied to the face of the truss are noted as front (F) or back (B).
- LOAD CASE(S)** Standard
- 1) Dead + Roof Live (balanced): Lumber Increase=1.25, Plate Increase=1.25  
Uniform Loads (lb/ft)  
Vert: 1-3=-60, 3-4=-20, 5-8=-20  
Concentrated Loads (lb)  
Vert: 9=-819 (B), 10=-817 (B), 11=-817 (B), 12=-817 (B)

This item has been digitally signed and sealed by O'Regan, Philip, PE on the date indicated here. Printed copies of this document are not considered signed and sealed and the signature must be verified on any electronic copies.

Philip J. O'Regan PE No.58126  
MiTek Inc. DBA MiTek USA FL Cert 6634  
16023 Swingley Ridge Rd. Chesterfield, MO 63017  
Date:

May 22, 2026

**WARNING - Verify design parameters and READ NOTES ON THIS AND INCLUDED MITEK REFERENCE PAGE MII-7473 rev. 1/2023 BEFORE USE.**

Design valid for use only with MiTek® connectors. This design is based only upon parameters shown, and is for an individual building component, not a truss system. Before use, the building designer must verify the applicability of design parameters and properly incorporate this design into the overall building design. Bracing indicated is to prevent buckling of individual truss web and/or chord members only. Additional temporary and permanent bracing is always required for stability and to prevent collapse with possible personal injury and property damage. For general guidance regarding the fabrication, storage, delivery, erection and bracing of trusses and truss systems, see **ANSI/TPI1 Quality Criteria and DSB-22** available from Truss Plate Institute (www.tpinst.org) and **BCSI Building Component Safety Information** available from the Structural Building Component Association (www.sbcsccomponents.com)

**MiTek®**  
16023 Swingley Ridge Rd.  
Chesterfield, MO 63017  
314.434.1200 / MiTek-US.com

Job 5449020	Truss T04G	Truss Type Scissor	Qty 1	Ply 1	Job Reference (optional) T41274295
----------------	---------------	-----------------------	----------	----------	---------------------------------------

Builders FirstSource (Lake City,FL), Lake City, FL - 32055,

Run: 25.40 S Apr 17 2026 Print: 25.4.0 S Apr 17 2026 MiTek Industries, Inc. Wed May 20 15:14:29

Page: 1

ID:wQwAIRGqslA5VtwRVOEH9hzEbWf-RfC?PsB70Hq3NSgPqnL8w3uITXbGKWrCDoi7J4zJC?f

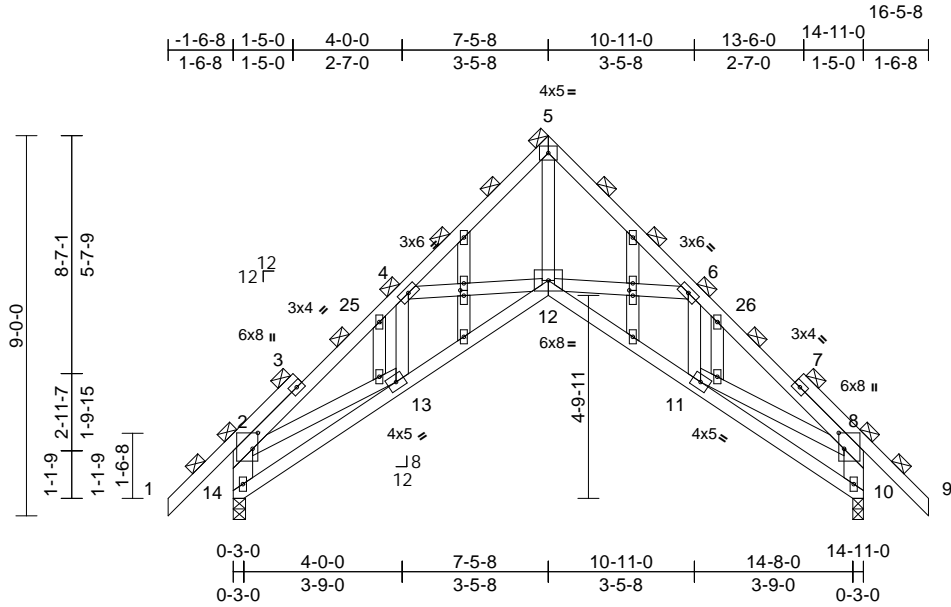

Scale = 1:54.5

Plate Offsets (X, Y): [2:0-4-8,0-1-8], [8:0-4-8,0-1-8], [15:0-1-8,0-1-0], [22:0-1-8,0-1-0]

Loading	(psf)	Spacing	2-0-0	CSI	DEFL	in	(loc)	l/defl	L/d	PLATES	GRIP	
TCLL (roof)	20.0	Plate Grip DOL	1.25	TC	0.28	Vert(LL)	-0.04	12	>999	240	MT20	244/190
TCDL	10.0	Lumber DOL	1.25	BC	0.22	Vert(CT)	-0.07	11-12	>999	180		
BCLL	0.0*	Rep Stress Incr	YES	WB	0.38	Horz(CT)	-0.11	14	n/a	n/a		
BCDL	10.0	Code	FBC2023/TPI2014	Matrix-MS							Weight: 121 lb	FT = 20%

**LUMBER**  
TOP CHORD 2x4 SP No.2  
BOT CHORD 2x4 SP No.2  
WEBS 2x4 SP No.3 \*Except\* 14-2,10-8:2x6 SP No.2  
OTHERS 2x4 SP No.3

**BRACING**  
TOP CHORD 2-0-0 oc purlins, except end verticals.  
BOT CHORD Rigid ceiling directly applied or 10-0-0 oc bracing.

**REACTIONS** (size) 10=0-3-0, 14=0-3-8  
Max Horiz 10=-255 (LC 10)  
Max Uplift 10=-153 (LC 13), 14=-153 (LC 12)  
Max Grav 10=685 (LC 1), 14=685 (LC 1)

**FORCES** (lb) - Maximum Compression/Maximum Tension  
TOP CHORD 1-2=0/70, 2-4=-1080/178, 4-5=-1022/149, 5-6=-986/117, 6-8=-1147/237, 8-9=0/70, 2-14=-716/259, 8-10=-759/253  
BOT CHORD 13-14=-30/167, 12-13=-43/915, 11-12=-280/1102, 10-11=-271/408  
WEBS 5-12=-145/1163, 4-12=-216/260, 4-13=-119/32, 6-12=-202/233, 6-11=-115/34, 2-13=-32/674, 8-11=-28/656

**NOTES**  
1) Unbalanced roof live loads have been considered for this design.  
2) Designed to ASCE 7-22 basic load combinations for allowable stress design unless otherwise noted.  
3) Wind: ASCE 7-22; Vult=130mph (3-second gust) Vasd=101mph; TC DL=4.2psf; BCDL=3.0psf; h=18ft; Cat. II; Exp B; Enclosed; MWFRS (envelope) exterior (2) zone and C-C Zone3 -1-6-8 to 1-5-8, Zone1 1-5-8 to 7-5-8, Zone2 7-5-8 to 11-8-7, Zone1 11-8-7 to 16-5-8 zone; end vertical left and right exposed; C-C for members and forces & MWFRS for reactions shown; Lumber DOL=1.60 plate grip DOL=1.60

- Truss designed for wind loads in the plane of the truss only. For studs exposed to wind (normal to the face), see Standard Industry Gable End Details as applicable, or consult qualified building designer as per ANSI/TPI 1.
- Building Designer / Project engineer responsible for verifying applied roof live load shown covers rain loading requirements specific to the use of this truss component.
- All plates are 2x4 (||) MT20 unless otherwise indicated.
- Gable studs spaced at 2-0-0 oc.
- This truss has been designed for a 10.0 psf bottom chord live load nonconcurrent with any other live loads.
- \* This truss has been designed for a live load of 20.0psf on the bottom chord in all areas where a rectangle 3-06-00 tall by 2-00-00 wide will fit between the bottom chord and any other members.
- Bearing at joint(s) 14, 10 considers parallel to grain value using ANSI/TPI 1 angle to grain formula. Building designer should verify capacity of bearing surface.
- Provide mechanical connection (by others) of truss to bearing plate capable of withstanding 153 lb uplift at joint 14 and 153 lb uplift at joint 10.
- Graphical purlin representation does not depict the size or the orientation of the purlin along the top and/or bottom chord.

**LOAD CASE(S)** Standard

This item has been digitally signed and sealed by O'Regan, Philip, PE on the date indicated here. Printed copies of this document are not considered signed and sealed and the signature must be verified on any electronic copies.

Philip J. O'Regan PE No.58126  
MiTek Inc. DBA MiTek USA FL Cert 6634  
16023 Swingley Ridge Rd. Chesterfield, MO 63017  
Date:

May 22, 2026

**WARNING - Verify design parameters and READ NOTES ON THIS AND INCLUDED MITEK REFERENCE PAGE MII-7473 rev. 1/2/2023 BEFORE USE.**

Design valid for use only with MiTek® connectors. This design is based only upon parameters shown, and is for an individual building component, not a truss system. Before use, the building designer must verify the applicability of design parameters and properly incorporate this design into the overall building design. Bracing indicated is to prevent buckling of individual truss web and/or chord members only. Additional temporary and permanent bracing is always required for stability and to prevent collapse with possible personal injury and property damage. For general guidance regarding the fabrication, storage, delivery, erection and bracing of trusses and truss systems, see **ANSI/TPI1 Quality Criteria and DSB-22** available from Truss Plate Institute (www.tpinst.org) and **BCSI Building Component Safety Information** available from the Structural Building Component Association (www.sbcsccomponents.com)

**MiTek®**  
16023 Swingley Ridge Rd.  
Chesterfield, MO 63017  
314.434.1200 / MiTek-US.com

Job 5449020	Truss T05	Truss Type Piggyback Base	Qty 4	Ply 1	Job Reference (optional)	T41274296
----------------	--------------	------------------------------	----------	----------	--------------------------	-----------

Builders FirstSource (Lake City,FL), Lake City, FL - 32055,

Run: 25.40 S Apr 17 2026 Print: 25.4.0 S Apr 17 2026 MiTek Industries, Inc. Wed May 20 15:14:29

Page: 1

ID:Zix7uYaBTBUogL\_pj4cDRGzEbPo-RfC?PsB70Hq3NSgPqnL8w3uITxbGKWrCDoi7J4zJC?F

TOP CHORD UNDER PIGGYBACKS TO BE LATERALLY BRACED BY PURLINS AT 2-0-0 OC. MAX. (TYPICAL)

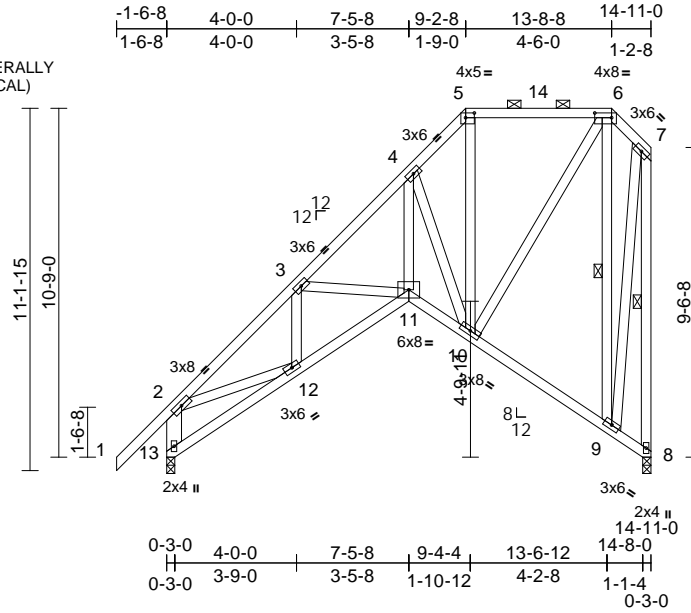

Scale = 1:71

Plate Offsets (X, Y): [5:0-3-4,0-1-12], [6:0-6-4,0-1-12]

Loading	(psf)	Spacing	2-0-0	CSI	DEFL	in	(loc)	l/defl	L/d	PLATES	GRIP	
TCLL (roof)	20.0	Plate Grip DOL	1.25	TC	0.27	Vert(LL)	0.06	11-12	>999	240	MT20	244/190
TCDL	10.0	Lumber DOL	1.25	BC	0.22	Vert(CT)	-0.07	11-12	>999	180		
BCLL	0.0*	Rep Stress Incr	YES	WB	0.48	Horz(CT)	0.10	8	n/a	n/a		
BCDL	10.0	Code	FBC2023/TPI2014	Matrix-MS							Weight: 152 lb	FT = 20%

**LUMBER**  
TOP CHORD 2x4 SP No.2  
BOT CHORD 2x4 SP No.2  
WEBS 2x4 SP No.3 \*Except\* 13-2:2x6 SP No.2

**BRACING**  
TOP CHORD Structural wood sheathing directly applied, except end verticals, and 2-0-0 oc purlins: 5-6.  
BOT CHORD Rigid ceiling directly applied or 6-0-0 oc bracing.  
WEBS 1 Row at midpt 6-9, 7-8

**REACTIONS** (size) 8=0-3-0, 13=0-3-0  
Max Horiz 13=383 (LC 12)  
Max Uplift 8=252 (LC 12), 13=89 (LC 12)  
Max Grav 8=575 (LC 1), 13=694 (LC 1)

**FORCES** (lb) - Maximum Compression/Maximum Tension  
TOP CHORD 1-2=0/75, 2-3=-954/431, 3-4=-852/415, 4-5=-457/248, 5-6=-341/202, 6-7=-110/56, 7-8=-555/234, 2-13=-660/345  
BOT CHORD 12-13=-451/346, 11-12=-664/949, 10-11=-469/737, 9-10=-39/109, 8-9=-9/26  
WEBS 5-10=-90/163, 6-10=-286/471, 6-9=-484/250, 7-9=-192/483, 2-12=-184/636, 3-11=-164/156, 3-12=-145/88, 4-11=-616/963, 4-10=-889/620

- Building Designer / Project engineer responsible for verifying applied roof live load shown covers rain loading requirements specific to the use of this truss component.
- Provide adequate drainage to prevent water ponding.
- This truss has been designed for a 10.0 psf bottom chord live load nonconcurrent with any other live loads.
- \* This truss has been designed for a live load of 20.0psf on the bottom chord in all areas where a rectangle 3-06-00 tall by 2-00-00 wide will fit between the bottom chord and any other members.
- Bearing at joint(s) 13, 8 considers parallel to grain value using ANSI/TPI 1 angle to grain formula. Building designer should verify capacity of bearing surface.
- Provide mechanical connection (by others) of truss to bearing plate at joint(s) 13.
- Provide mechanical connection (by others) of truss to bearing plate capable of withstanding 89 lb uplift at joint 13 and 252 lb uplift at joint 8.
- Graphical purlin representation does not depict the size or the orientation of the purlin along the top and/or bottom chord.

**LOAD CASE(S)** Standard

- NOTES**
- Unbalanced roof live loads have been considered for this design.
  - Designed to ASCE 7-22 basic load combinations for allowable stress design unless otherwise noted.
  - Wind: ASCE 7-22; Vult=130mph (3-second gust) Vasd=101mph; TC DL=4.2psf; BC DL=3.0psf; h=18ft; Cat. II; Exp B; Enclosed; MWFRS (envelope) exterior (2) zone and C-C Zone1 -1-6-8 to 9-2-8, Zone3 9-2-8 to 13-8-8, Zone1 13-8-8 to 14-9-4 zone;C-C for members and forces & MWFRS for reactions shown; Lumber DOL=1.60 plate grip DOL=1.60

This item has been digitally signed and sealed by ORegan, Philip, PE on the date indicated here. Printed copies of this document are not considered signed and sealed and the signature must be verified on any electronic copies.

Philip J. O'Regan PE No.58126  
MiTek Inc. DBA MiTek USA FL Cert 6634  
16023 Swingley Ridge Rd. Chesterfield, MO 63017  
Date:

May 22,2026

**WARNING - Verify design parameters and READ NOTES ON THIS AND INCLUDED MITEK REFERENCE PAGE MII-7473 rev. 1/2/2023 BEFORE USE.**

Design valid for use only with MiTek® connectors. This design is based only upon parameters shown, and is for an individual building component, not a truss system. Before use, the building designer must verify the applicability of the design parameters and properly incorporate this design into the overall building design. Bracing indicated is to prevent buckling of individual truss web and/or chord members only. Additional temporary and permanent bracing is always required for stability and to prevent collapse with possible personal injury and property damage. For general guidance regarding the fabrication, storage, delivery, erection and bracing of trusses and truss systems, see **ANSI/TPI1 Quality Criteria and DSB-22** available from Truss Plate Institute (www.tpinst.org) and **BCSI Building Component Safety Information** available from the Structural Building Component Association (www.sbcsccomponents.com)

**MiTek®**  
16023 Swingley Ridge Rd.  
Chesterfield, MO 63017  
314.434.1200 / MiTek-US.com

Job 5449020	Truss T05G	Truss Type Piggyback Base Structural Gable	Qty 1	Ply 1	Job Reference (optional) T41274297
----------------	---------------	-----------------------------------------------	----------	----------	---------------------------------------

Builders FirstSource (Lake City,FL), Lake City, FL - 32055,

Run: 25.40 S Apr 17 2026 Print: 25.4.0 S Apr 17 2026 MiTek Industries, Inc. Wed May 20 15:14:29  
ID:5oZctfWEaxNX7G5YgxD4vEbBg-RfC?PsB70Hq3NSgPqnL8w3uTXbGKWrCDoi7J4zJC?f

Page: 1

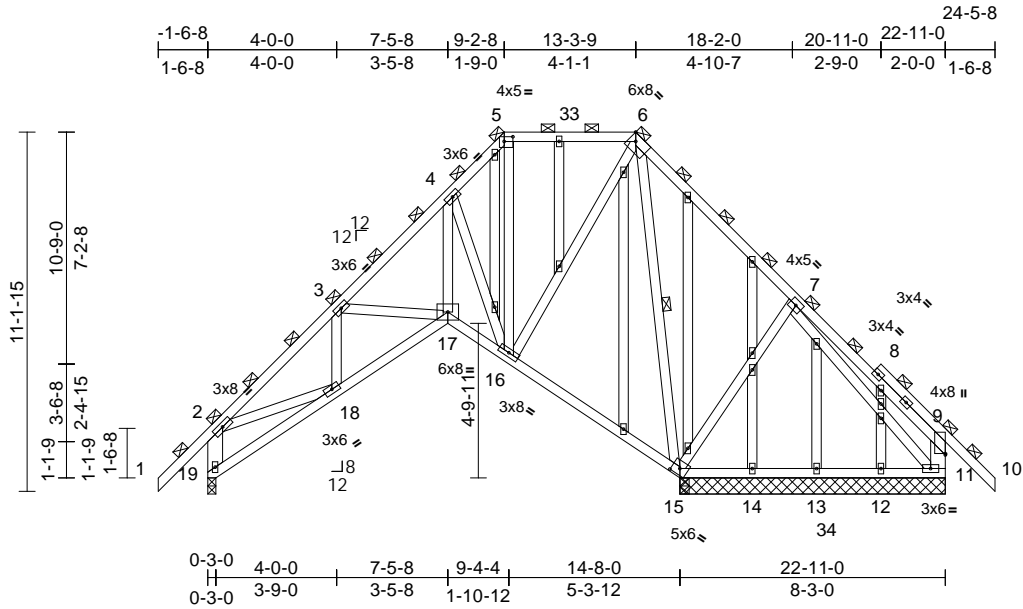

Scale = 1:71.6

Plate Offsets (X, Y): [5:0-3-4,0-1-12], [6:0-2-8,Edge], [15:0-3-0,0-2-3]

Loading	(psf)	Spacing	2-0-0	CSI	DEFL	in	(loc)	l/defl	L/d	PLATES	GRIP	
TCLL (roof)	20.0	Plate Grip DOL	1.25	TC	0.32	Vert(LL)	-0.03	15-16	>999	240	MT20	244/190
TCDL	10.0	Lumber DOL	1.25	BC	0.23	Vert(CT)	-0.06	15-16	>999	180		
BCLL	0.0*	Rep Stress Incr	YES	WB	0.55	Horz(CT)	0.06	15	n/a	n/a		
BCDL	10.0	Code	FBC2023/TPI2014	Matrix-MS							Weight: 242 lb	FT = 20%

**LUMBER**  
TOP CHORD 2x4 SP No.2  
BOT CHORD 2x4 SP No.2  
WEBS 2x4 SP No.3 \*Except\* 19-2,11-9:2x6 SP No.2  
OTHERS 2x4 SP No.3

**BRACING**  
TOP CHORD 2-0-0 oc purlins, except end verticals.  
BOT CHORD Rigid ceiling directly applied or 6-0-0 oc bracing.  
WEBS 1 Row at midpt 6-15

**REACTIONS** (size) 11=8-3-0, 12=8-3-0, 13=8-3-0, 14=8-3-0, 15=8-3-0, 19=0-3-0  
Max Horiz 19=268 (LC 11)  
Max Uplift 11=-233 (LC 13), 15=-364 (LC 12), 19=-180 (LC 13)  
Max Grav 11=218 (LC 26), 12=88 (LC 3), 13=113 (LC 18), 14=84 (LC 18), 15=1423 (LC 19), 19=574 (LC 20)

**FORCES** (lb) - Maximum Compression/Maximum Tension  
TOP CHORD 1-2=0/75, 2-3=-742/188, 3-4=-476/103, 4-5=-221/173, 5-6=-163/132, 6-7=-125/596, 7-9=-93/215, 9-10=0/70, 2-19=-565/225, 9-11=-228/216  
BOT CHORD 18-19=-309/351, 17-18=-303/792, 16-17=-192/568, 15-16=-297/205, 14-15=-197/97, 13-14=-197/97, 12-13=-197/97, 11-12=-197/97  
WEBS 5-16=-93/74, 6-16=-182/615, 6-15=-1064/269, 7-15=-299/257, 7-11=-126/264, 3-17=-241/210, 4-17=-263/764, 4-16=-741/270, 3-18=-67/59, 2-18=-14/453

**NOTES**  
1) Unbalanced roof live loads have been considered for this design.  
2) Designed to ASCE 7-22 basic load combinations for allowable stress design unless otherwise noted.

- Wind: ASCE 7-22; Vult=130mph (3-second gust) Vasd=101mph; TCCL=4.2psf; BCDL=3.0psf; h=18ft; Cat II; Exp B; Enclosed; MWFRS (envelope) exterior (2) zone and C-C Zone1 -1-6-8 to 9-2-8, Zone3 9-2-8 to 13-3-9, Zone1 13-3-9 to 24-5-8 zone; C-C for members and forces & MWFRS for reactions shown; Lumber DOL=1.60 plate grip DOL=1.60
- Truss designed for wind loads in the plane of the truss only. For studs exposed to wind (normal to the face), see Standard Industry Gable End Details as applicable, or consult qualified building designer as per ANSI/TPI 1.
- Building Designer / Project engineer responsible for verifying applied roof live load shown covers rain loading requirements specific to the use of this truss component.
- Provide adequate drainage to prevent water ponding.
- All plates are 2x4 (||) MT20 unless otherwise indicated.
- Gable studs spaced at 2-0-0 oc.
- This truss has been designed for a 10.0 psf bottom chord live load nonconcurrent with any other live loads.
- \* This truss has been designed for a live load of 20.0psf on the bottom chord in all areas where a rectangle 3-06-00 tall by 2-00-00 wide will fit between the bottom chord and any other members, with BCDL = 10.0psf.
- Bearing at joint(s) 19 considers parallel to grain value using ANSI/TPI 1 angle to grain formula. Building designer should verify capacity of bearing surface.
- Provide mechanical connection (by others) of truss to bearing plate at joint(s) 19.
- Provide mechanical connection (by others) of truss to bearing plate capable of withstanding 180 lb uplift at joint 19, 364 lb uplift at joint 15 and 233 lb uplift at joint 11.
- Graphical purlin representation does not depict the size or the orientation of the purlin along the top and/or bottom chord.

**LOAD CASE(S)** Standard

This item has been digitally signed and sealed by O'Regan, Philip, PE on the date indicated here. Printed copies of this document are not considered signed and sealed and the signature must be verified on any electronic copies.

Philip J. O'Regan PE No.58126  
MiTek Inc. DBA MiTek USA FL Cert 6634  
16023 Swingley Ridge Rd. Chesterfield, MO 63017  
Date:

May 22, 2026

**WARNING - Verify design parameters and READ NOTES ON THIS AND INCLUDED MITEK REFERENCE PAGE MII-7473 rev. 1/2023 BEFORE USE.**

Design valid for use only with MiTek® connectors. This design is based only upon parameters shown, and is for an individual building component, not a truss system. Before use, the building designer must verify the applicability of the design parameters and properly incorporate this design into the overall building design. Bracing indicated is to prevent buckling of individual truss web and/or chord members only. Additional temporary and permanent bracing is always required for stability and to prevent collapse with possible personal injury and property damage. For general guidance regarding the fabrication, storage, delivery, erection and bracing of trusses and truss systems, see **ANSI/TPI1 Quality Criteria and DSB-22** available from Truss Plate Institute (www.tpinst.org) and **BCSI Building Component Safety Information** available from the Structural Building Component Association (www.sbcsccomponents.com)

**MiTek®**

16023 Swingley Ridge Rd.  
Chesterfield, MO 63017  
314.434.1200 / MiTek-US.com

Job 5449020	Truss T06	Truss Type Piggyback Base	Qty 3	Ply 1	Job Reference (optional) T41274298
----------------	--------------	------------------------------	----------	----------	---------------------------------------

Builders FirstSource (Lake City,FL), Lake City, FL - 32055,

Run: 25.40 S Apr 17 2026 Print: 25.4.0 S Apr 17 2026 MiTek Industries, Inc. Wed May 20 15:14:29  
 ID:Xzk9\_Mf4y19OJn8soCIZQYzEbN6-RfC?PsB70Hq3NSgPqnL8w3uITXbGKWrCDoi7J4zJC?f

Page: 1

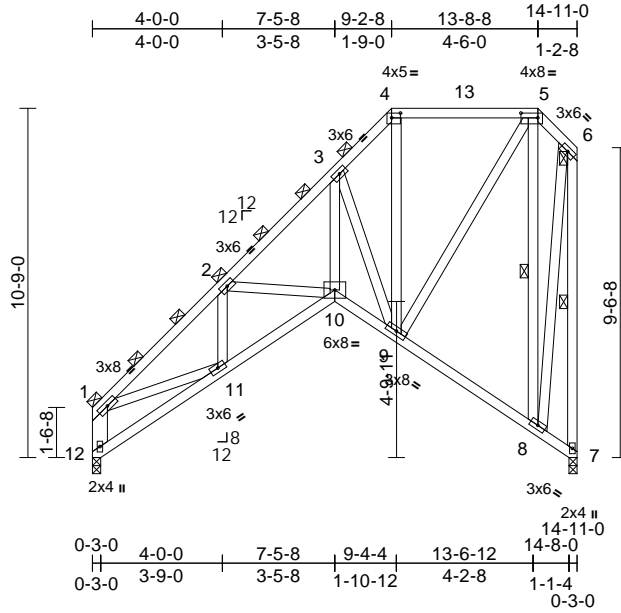

Scale = 1:70.9  
 Plate Offsets (X, Y): [4:0-3-4,0-1-12], [5:0-6-4,0-1-12]

Loading	(psf)	Spacing	2-0-0	CSI	DEFL	in (loc)	l/defl	L/d	PLATES	GRIP
TCLL (roof)	20.0	Plate Grip DOL	1.25	TC	0.25	Vert(LL)	0.06	10-11	>999	240
TCDL	10.0	Lumber DOL	1.25	BC	0.23	Vert(CT)	-0.07	10-11	>999	180
BCLL	0.0*	Rep Stress Incr	YES	WB	0.48	Horz(CT)	0.10	7	n/a	n/a
BCDL	10.0	Code	FBC2023/TPI2014	Matrix-MS						
										Weight: 149 lb FT = 20%

**LUMBER**  
 TOP CHORD 2x4 SP No.2  
 BOT CHORD 2x4 SP No.2  
 WEBS 2x4 SP No.3 \*Except\* 12-1:2x6 SP No.2

**BRACING**  
 TOP CHORD 2-0-0 oc purlins, except end verticals, and sheathed: 4-5.  
 BOT CHORD Rigid ceiling directly applied or 6-0-0 oc bracing.  
 WEBS 1 Row at midpt 5-8, 6-7

**REACTIONS** (size) 7=0-3-0, 12=0-3-0  
 Max Horiz 12=324 (LC 12)  
 Max Uplift 7=-252 (LC 12), 12=-44 (LC 12)  
 Max Grav 7=582 (LC 1), 12=582 (LC 1)

**FORCES** (lb) - Maximum Compression/Maximum Tension  
 TOP CHORD 1-2=-987/430, 2-3=-871/418, 3-4=-457/247, 4-5=-342/203, 5-6=-110/56, 6-7=-561/234, 1-12=-572/287  
 BOT CHORD 11-12=-425/334, 10-11=-672/958, 9-10=-470/739, 8-9=-39/109, 7-8=-10/26  
 WEBS 4-9=-88/163, 5-9=-287/473, 5-8=-490/251, 6-8=-193/488, 1-11=-213/629, 2-10=-170/163, 3-10=-621/970, 3-9=-891/619, 2-11=-142/99

- Building Designer / Project engineer responsible for verifying applied roof live load shown covers rain loading requirements specific to the use of this truss component.
- Provide adequate drainage to prevent water ponding.
- This truss has been designed for a 10.0 psf bottom chord live load nonconcurrent with any other live loads.
- \* This truss has been designed for a live load of 20.0psf on the bottom chord in all areas where a rectangle 3-06-00 tall by 2-00-00 wide will fit between the bottom chord and any other members.
- Bearing at joint(s) 7, 12 considers parallel to grain value using ANSI/TPI 1 angle to grain formula. Building designer should verify capacity of bearing surface.
- Provide mechanical connection (by others) of truss to bearing plate at joint(s) 7, 12.
- Provide mechanical connection (by others) of truss to bearing plate capable of withstanding 252 lb uplift at joint 7 and 44 lb uplift at joint 12.
- Graphical purlin representation does not depict the size or the orientation of the purlin along the top and/or bottom chord.

**LOAD CASE(S)** Standard

- NOTES**
- Unbalanced roof live loads have been considered for this design.
  - Designed to ASCE 7-22 basic load combinations for allowable stress design unless otherwise noted.
  - Wind: ASCE 7-22; Vult=130mph (3-second gust) Vasd=101mph; TC DL=4.2psf; BC DL=3.0psf; h=18ft; Cat. II; Exp B; Enclosed; MWFRS (envelope) exterior (2) zone and C-C Zone1 0-2-12 to 9-2-8, Zone3 9-2-8 to 13-8-8, Zone1 13-8-8 to 14-9-4 zone;C-C for members and forces & MWFRS for reactions shown; Lumber DOL=1.60 plate grip DOL=1.60

This item has been digitally signed and sealed by O'Regan, Philip, PE on the date indicated here. Printed copies of this document are not considered signed and sealed and the signature must be verified on any electronic copies.

Philip J. O'Regan PE No.58126  
 MiTek Inc. DBA MiTek USA FL Cert 6634  
 16023 Swingley Ridge Rd. Chesterfield, MO 63017  
 Date:

May 22,2026

<p><b>WARNING - Verify design parameters and READ NOTES ON THIS AND INCLUDED MITEK REFERENCE PAGE MII-7473 rev. 1/2/2023 BEFORE USE.</b></p> <p>Design valid for use only with MiTek® connectors. This design is based only upon parameters shown, and is for an individual building component, not a truss system. Before use, the building designer must verify the applicability of design parameters and properly incorporate this design into the overall building design. Bracing indicated is to prevent buckling of individual truss web and/or chord members only. Additional temporary and permanent bracing is always required for stability and to prevent collapse with possible personal injury and property damage. For general guidance regarding the fabrication, storage, delivery, erection and bracing of trusses and truss systems, see <b>ANSI/TPI1 Quality Criteria and DSB-22</b> available from Truss Plate Institute (www.tpinst.org) and <b>BCSI Building Component Safety Information</b> available from the Structural Building Component Association (www.sbcsccomponents.com)</p>	 <p>16023 Swingley Ridge Rd.          Chesterfield, MO 63017          314.434.1200 / MiTek-US.com</p>
------------------------------------------------------------------------------------------------------------------------------------------------------------------------------------------------------------------------------------------------------------------------------------------------------------------------------------------------------------------------------------------------------------------------------------------------------------------------------------------------------------------------------------------------------------------------------------------------------------------------------------------------------------------------------------------------------------------------------------------------------------------------------------------------------------------------------------------------------------------------------------------------------------------------------------------------------------------------------------------------------------------------------------------------------------------------------------------------------------------	----------------------------------------------------------------------------------------------------------------------------------------------------------------------------------------------------

Job 5449020	Truss T07	Truss Type Piggyback Base	Qty 3	Ply 1	Job Reference (optional) T41274299
----------------	--------------	------------------------------	----------	----------	---------------------------------------

Builders FirstSource (Lake City,FL), Lake City, FL - 32055,

Run: 25.40 S Apr 17 2026 Print: 25.4.0 S Apr 17 2026 MiTek Industries, Inc. Wed May 20 15:14:29  
ID:idYARICJMsq0Ch4Ww976k1zEbMP-RfC?PsB70Hq3NSgPqnL8w3uiTXbGKWrCDoi7J4zJC?f

Page: 1

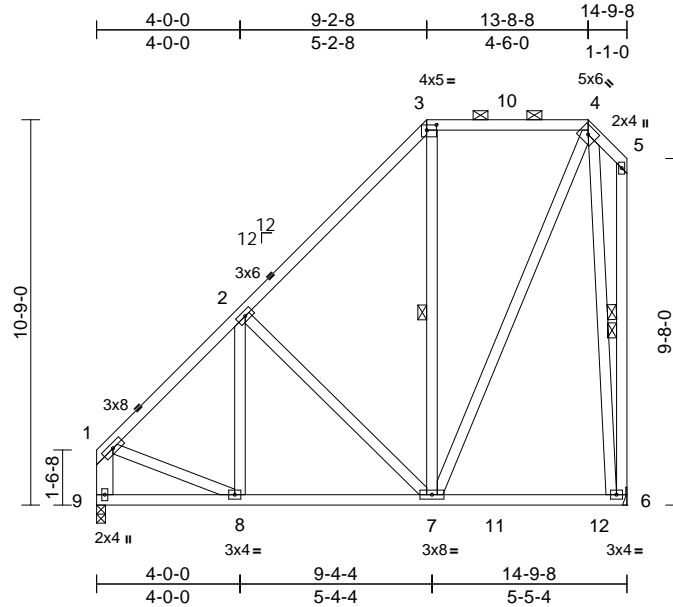

Scale = 1:64.3

Plate Offsets (X, Y): [3:0-3-4,0-1-12]

Loading	(psf)	Spacing	2-0-0	CSI	DEFL	in	(loc)	l/defl	L/d	PLATES	GRIP	
TCLL (roof)	20.0	Plate Grip DOL	1.25	TC	0.28	Vert(LL)	-0.04	6-7	>999	240	MT20	244/190
TCDL	10.0	Lumber DOL	1.25	BC	0.33	Vert(CT)	-0.07	6-7	>999	180		
BCLL	0.0*	Rep Stress Incr	YES	WB	0.61	Horz(CT)	-0.01	6	n/a	n/a		
BCDL	10.0	Code	FBC2023/TPI2014	Matrix-MS								Weight: 138 lb FT = 20%

**LUMBER**

- TOP CHORD 2x4 SP No.2
- BOT CHORD 2x4 SP No.2
- WEBS 2x4 SP No.3 \*Except\* 9-1:2x6 SP No.2

**BRACING**

- TOP CHORD Structural wood sheathing directly applied, except end verticals, and 2-0-0 oc purlins: 3-4.
- BOT CHORD Rigid ceiling directly applied or 10-0-0 oc bracing.
- WEBS 1 Row at midpt 3-7, 5-6, 4-6

**REACTIONS**

- (size) 6= Mechanical, 9=0-3-0
- Max Horiz 9=327 (LC 12)
- Max Uplift 6=-256 (LC 12), 9=-40 (LC 12)
- Max Grav 6=650 (LC 2), 9=619 (LC 2)

**FORCES**

- (lb) - Maximum Compression/Maximum Tension
- TOP CHORD 1-2=-566/48, 2-3=-409/85, 3-4=-235/140, 4-5=-27/48, 1-9=-562/49, 5-6=-35/20
- BOT CHORD 8-9=-337/244, 7-8=-299/449, 6-7=-23/52
- WEBS 2-7=-298/251, 3-7=-91/92, 4-7=-248/488, 2-8=-26/100, 1-8=0/359, 4-6=-541/253

**NOTES**

- Unbalanced roof live loads have been considered for this design.
- Designed to ASCE 7-22 basic load combinations for allowable stress design unless otherwise noted.
- Wind: ASCE 7-22; Vult=130mph (3-second gust) Vasd=101mph; TC DL=4.2psf; BC DL=3.0psf; h=18ft; Cat. II; Exp B; Enclosed; MWFRS (envelope) exterior (2) zone and C-C Zone1 0-2-12 to 9-2-8, Zone3 9-2-8 to 13-8-8, Zone1 13-8-8 to 14-7-12 zone;C-C for members and forces & MWFRS for reactions shown; Lumber DOL=1.60 plate grip DOL=1.60
- Building Designer / Project engineer responsible for verifying applied roof live load shown covers rain loading requirements specific to the use of this truss component.
- Provide adequate drainage to prevent water ponding.

- This truss has been designed for a 10.0 psf bottom chord live load nonconcurrent with any other live loads.
- \* This truss has been designed for a live load of 20.0psf on the bottom chord in all areas where a rectangle 3-06-00 tall by 2-00-00 wide will fit between the bottom chord and any other members, with BCDL = 10.0psf.
- Refer to girder(s) for truss to truss connections.
- Provide mechanical connection (by others) of truss to bearing plate capable of withstanding 40 lb uplift at joint 9 and 256 lb uplift at joint 6.
- Graphical purlin representation does not depict the size or the orientation of the purlin along the top and/or bottom chord.

**LOAD CASE(S)** Standard

This item has been digitally signed and sealed by O'Regan, Philip, PE on the date indicated here. Printed copies of this document are not considered signed and sealed and the signature must be verified on any electronic copies.

Philip J. O'Regan PE No.58126  
MiTek Inc. DBA MiTek USA FL Cert 6634  
16023 Swingley Ridge Rd. Chesterfield, MO 63017  
Date:

May 22,2026

**WARNING - Verify design parameters and READ NOTES ON THIS AND INCLUDED MITEK REFERENCE PAGE MII-7473 rev. 1/2/2023 BEFORE USE.**

Design valid for use only with MiTek® connectors. This design is based only upon parameters shown, and is for an individual building component, not a truss system. Before use, the building designer must verify the applicability of design parameters and properly incorporate this design into the overall building design. Bracing indicated is to prevent buckling of individual truss web and/or chord members only. Additional temporary and permanent bracing is always required for stability and to prevent collapse with possible personal injury and property damage. For general guidance regarding the fabrication, storage, delivery, erection and bracing of trusses and truss systems, see **ANSI/TPI1 Quality Criteria and DSB-22** available from Truss Plate Institute (www.tpinst.org) and **BCSI Building Component Safety Information** available from the Structural Building Component Association (www.sbcsccomponents.com)

**MiTek®**

16023 Swingley Ridge Rd.  
Chesterfield, MO 63017  
314.434.1200 / MiTek-US.com

Job 5449020	Truss T08	Truss Type Piggyback Base	Qty 4	Ply 1	Job Reference (optional)	T41274300
----------------	--------------	------------------------------	----------	----------	--------------------------	-----------

Builders FirstSource (Lake City,FL), Lake City, FL - 32055,

Run: 25.40 S Apr 17 2026 Print: 25.4.0 S Apr 17 2026 MiTek Industries, Inc. Wed May 20 15:14:30

Page: 1

ID:BdiqLXqw6qNdRh2Vz4xlr?zEbLb-RfC?PsB70Hq3NSgPqnL8w3uTXbGKWRcDoi7J4zJC?f

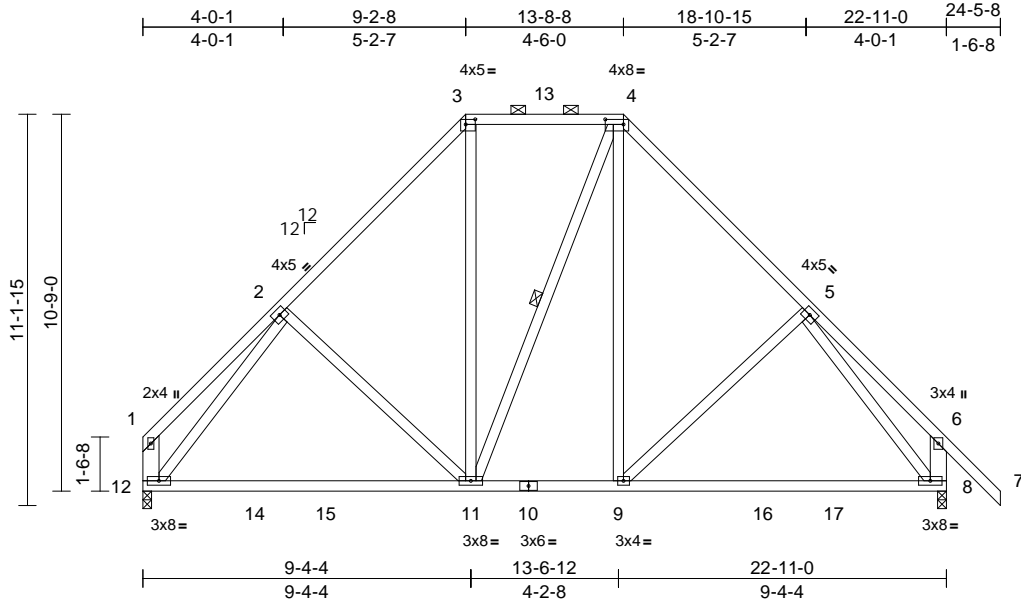

Scale = 1:65.7  
Plate Offsets (X, Y): [3:0-3-4,0-1-12], [4:0-6-4,0-1-12]

Loading	(psf)	Spacing	2-0-0	CSI	DEFL	in	(loc)	l/defl	L/d	PLATES	GRIP	
TCLL (roof)	20.0	Plate Grip DOL	1.25	TC	0.32	Vert(LL)	-0.25	8-9	>999	240	MT20	244/190
TCDL	10.0	Lumber DOL	1.25	BC	0.83	Vert(CT)	-0.44	8-9	>607	180		
BCLL	0.0*	Rep Stress Incr	YES	WB	0.61	Horz(CT)	0.02	8	n/a	n/a		
BCDL	10.0	Code	FBC2023/TPI2014	Matrix-MS							Weight: 175 lb	FT = 20%

**LUMBER**  
TOP CHORD 2x4 SP No.2  
BOT CHORD 2x4 SP No.2  
WEBS 2x4 SP No.3 \*Except\* 12-1,8-6:2x6 SP No.2

**BRACING**  
TOP CHORD Structural wood sheathing directly applied, except end verticals, and 2-0-0 oc purlins: 3-4.  
BOT CHORD Rigid ceiling directly applied or 10-0-0 oc bracing.  
WEBS 1 Row at midpt 4-11

**REACTIONS**  
(size) 8=0-3-0, 12=0-3-0  
Max Horiz 12=-252 (LC 8)  
Max Uplift 8=-229 (LC 13), 12=-185 (LC 12)  
Max Grav 8=1097 (LC 2), 12=999 (LC 2)

**FORCES**  
(lb) - Maximum Compression/Maximum Tension  
TOP CHORD 1-2=-268/72, 2-3=-869/265, 3-4=-544/266, 4-5=-869/266, 5-6=-231/91, 6-7=0/75, 1-12=-235/77, 6-8=-314/137  
BOT CHORD 11-12=-213/737, 9-11=-60/603, 8-9=-79/583  
WEBS 2-11=-174/237, 3-11=-113/355, 4-11=-122/125, 4-9=-117/372, 5-9=-170/235, 2-12=-786/201, 5-8=-830/184

- Building Designer / Project engineer responsible for verifying applied roof live load shown covers rain loading requirements specific to the use of this truss component.
- Provide adequate drainage to prevent water ponding.
- This truss has been designed for a 10.0 psf bottom chord live load nonconcurrent with any other live loads.
- \* This truss has been designed for a live load of 20.0psf on the bottom chord in all areas where a rectangle 3-06-00 tall by 2-00-00 wide will fit between the bottom chord and any other members, with BCDL = 10.0psf.
- Provide mechanical connection (by others) of truss to bearing plate at joint(s) 12.
- Provide mechanical connection (by others) of truss to bearing plate capable of withstanding 185 lb uplift at joint 12 and 229 lb uplift at joint 8.
- Graphical purlin representation does not depict the size or the orientation of the purlin along the top and/or bottom chord.

**LOAD CASE(S)** Standard

- NOTES**
- Unbalanced roof live loads have been considered for this design.
  - Designed to ASCE 7-22 basic load combinations for allowable stress design unless otherwise noted.
  - Wind: ASCE 7-22; Vult=130mph (3-second gust) Vasd=101mph; TC DL=4.2psf; BCDL=3.0psf; h=18ft; Cat. II; Exp B; Enclosed; MWFRS (envelope) exterior (2) zone and C-C Zone1 0-2-12 to 9-2-8, Zone3 9-2-8 to 13-8-8, Zone1 13-8-8 to 24-5-8 zone;C-C for members and forces & MWFRS for reactions shown; Lumber DOL=1.60 plate grip DOL=1.60

This item has been digitally signed and sealed by O'Regan, Philip, PE on the date indicated here. Printed copies of this document are not considered signed and sealed and the signature must be verified on any electronic copies.

Philip J. O'Regan PE No.58126  
MiTek Inc. DBA MiTek USA FL Cert 6634  
16023 Swingley Ridge Rd. Chesterfield, MO 63017  
Date:

May 22,2026

<p><b>WARNING - Verify design parameters and READ NOTES ON THIS AND INCLUDED MITEK REFERENCE PAGE MII-7473 rev. 1/2/2023 BEFORE USE.</b></p> <p>Design valid for use only with MiTek® connectors. This design is based only upon parameters shown, and is for an individual building component, not a truss system. Before use, the building designer must verify the applicability of design parameters and properly incorporate this design into the overall building design. Bracing indicated is to prevent buckling of individual truss web and/or chord members only. Additional temporary and permanent bracing is always required for stability and to prevent collapse with possible personal injury and property damage. For general guidance regarding the fabrication, storage, delivery, erection and bracing of trusses and truss systems, see <b>ANSI/TPI1 Quality Criteria and DSB-22</b> available from Truss Plate Institute (www.tpinst.org) and <b>BCSI Building Component Safety Information</b> available from the Structural Building Component Association (www.sbcsccomponents.com)</p>	 <p>16023 Swingley Ridge Rd. Chesterfield, MO 63017 314.434.1200 / MiTek-US.com</p>
------------------------------------------------------------------------------------------------------------------------------------------------------------------------------------------------------------------------------------------------------------------------------------------------------------------------------------------------------------------------------------------------------------------------------------------------------------------------------------------------------------------------------------------------------------------------------------------------------------------------------------------------------------------------------------------------------------------------------------------------------------------------------------------------------------------------------------------------------------------------------------------------------------------------------------------------------------------------------------------------------------------------------------------------------------------------------------------------------------------	----------------------------------------------------------------------------------------------------------------------------------------------------------------------------------

Job 5449020	Truss T09	Truss Type Piggyback Base Girder	Qty 1	Ply 2	Job Reference (optional) T41274301
----------------	--------------	-------------------------------------	----------	----------	---------------------------------------

Builders FirstSource (Lake City,FL), Lake City, FL - 32055,

Run: 25.40 S Apr 17 2026 Print: 25.4.0 S Apr 17 2026 MiTek Industries, Inc. Wed May 20 15:14:30  
ID:Y6WhWWDFrZwumZkIREqjXzEb0R-RfC?PsB70Hq3NSgPqnL8w3uITXbGKWRcDoi7J4zJC?f

Page: 1

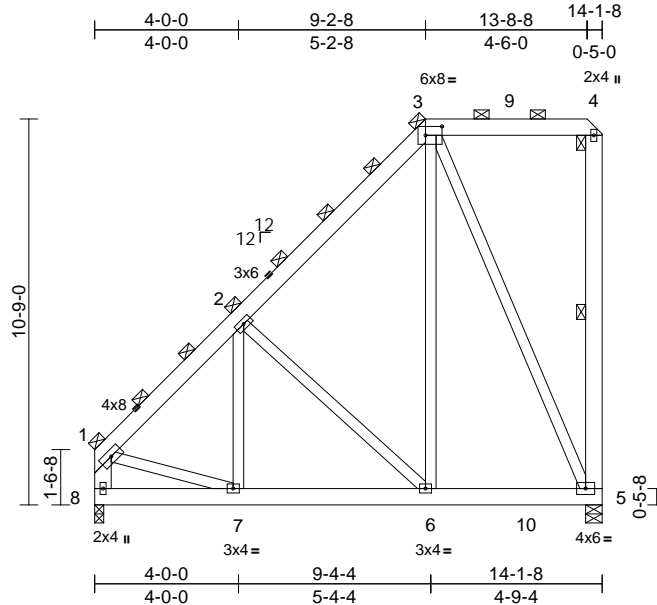

Scale = 1:64.1

Plate Offsets (X, Y): [3:0-5-8,0-3-0]

Loading	(psf)	Spacing	5-0-0	CSI	DEFL	in	(loc)	l/defl	L/d	PLATES	GRIP	
TCLL (roof)	20.0	Plate Grip DOL	1.25	TC	0.18	Vert(LL)	-0.01	6-7	>999	240	MT20	244/190
TCDL	10.0	Lumber DOL	1.25	BC	0.17	Vert(CT)	-0.03	6-7	>999	180		
BCLL	0.0*	Rep Stress Incr	NO	WB	0.63	Horz(CT)	-0.01	5	n/a	n/a		
BCDL	10.0	Code	FBC2023/TPI2014	Matrix-MS							Weight: 307 lb	FT = 20%

- LUMBER**  
TOP CHORD 2x6 SP No.2  
BOT CHORD 2x6 SP No.2  
WEBS 2x4 SP No.3 \*Except\* 8-1,5-4:2x6 SP No.2
- BRACING**  
TOP CHORD 2-0-0 oc purlins, except end verticals  
(Switched from sheeted: Spacing > 2-0-0).  
BOT CHORD Rigid ceiling directly applied or 10-0-0 oc  
bracing.  
WEBS 1 Row at midpt 4-5
- REACTIONS** (size) 5=0-5-8, 8=0-3-0  
Max Horiz 8=876 (LC 8)  
Max Uplift 5=-693 (LC 8), 8=-37 (LC 8)  
Max Grav 5=1529 (LC 2), 8=1492 (LC 15)
- FORCES** (lb) - Maximum Compression/Maximum  
Tension  
TOP CHORD 1-2=-1390/42, 2-3=-930/119, 3-4=-13/4,  
1-8=-1344/62, 4-5=-341/181  
BOT CHORD 7-8=-883/369, 6-7=-753/1089, 5-6=-294/540  
WEBS 2-7=-2/307, 2-6=-772/635, 3-6=-337/1070,  
3-5=-1278/702, 1-7=0/819

- Wind: ASCE 7-22; Vult=130mph (3-second gust)  
Vasd=101mph; TC DL=4.2psf; BCDL=3.0psf; h=18ft; Cat.  
II; Exp B; Enclosed; MWFRS (envelope) exterior (2)  
zone; Lumber DOL=1.60 plate grip DOL=1.60
- Building Designer / Project engineer responsible for  
verifying applied roof live load shown covers rain loading  
requirements specific to the use of this truss component.
- Provide adequate drainage to prevent water ponding.
- This truss has been designed for a 10.0 psf bottom chord  
live load nonconcurrent with any other live loads.
- \* This truss has been designed for a live load of 20.0psf  
on the bottom chord in all areas where a rectangle  
3-06-00 tall by 2-00-00 wide will fit between the bottom  
chord and any other members, with BCDL = 10.0psf.
- Provide mechanical connection (by others) of truss to  
bearing plate at joint(s) 8.
- Provide mechanical connection (by others) of truss to  
bearing plate capable of withstanding 37 lb uplift at joint 8  
and 693 lb uplift at joint 5.

**LOAD CASE(S)** Standard

- NOTES**
- 2-ply truss to be connected together with 10d (0.131"x3")  
nails as follows:  
Top chords connected as follows: 2x6 - 2 rows staggered  
at 0-9-0 oc.  
Bottom chords connected as follows: 2x6 - 2 rows  
staggered at 0-9-0 oc.  
Web connected as follows: 2x4 - 1 row at 0-9-0 oc.
  - All loads are considered equally applied to all plies,  
except if noted as front (F) or back (B) face in the LOAD  
CASE(S) section. Ply to ply connections have been  
provided to distribute only loads noted as (F) or (B),  
unless otherwise indicated.
  - Unbalanced roof live loads have been considered for this  
design.
  - Designed to ASCE 7-22 basic load combinations for  
allowable stress design unless otherwise noted.

This item has been  
digitally signed and  
sealed by O'Regan, Philip, PE  
on the date indicated here.  
Printed copies of this  
document are not considered  
signed and sealed and the  
signature must be verified  
on any electronic copies.

Philip J. O'Regan PE No.58126  
MiTek Inc. DBA MiTek USA FL Cert 6634  
16023 Swingley Ridge Rd. Chesterfield, MO 63017  
Date:

May 22, 2026

**WARNING - Verify design parameters and READ NOTES ON THIS AND INCLUDED MITEK REFERENCE PAGE MII-7473 rev. 1/2/2023 BEFORE USE.**

Design valid for use only with MiTek® connectors. This design is based only upon parameters shown, and is for an individual building component, not a truss system. Before use, the building designer must verify the applicability of design parameters and properly incorporate this design into the overall building design. Bracing indicated is to prevent buckling of individual truss web and/or chord members only. Additional temporary and permanent bracing is always required for stability and to prevent collapse with possible personal injury and property damage. For general guidance regarding the fabrication, storage, delivery, erection and bracing of trusses and truss systems, see **ANSI/TPI1 Quality Criteria and DSB-22** available from Truss Plate Institute (www.tpinst.org) and **BCSI Building Component Safety Information** available from the Structural Building Component Association (www.sbcsccomponents.com)

**MiTek®**

16023 Swingley Ridge Rd.  
Chesterfield, MO 63017  
314.434.1200 / MiTek-US.com

Job 5449020	Truss T10	Truss Type Hip Girder	Qty 1	Ply 1	Job Reference (optional) T41274302
----------------	--------------	--------------------------	----------	----------	---------------------------------------

Builders FirstSource (Lake City,FL), Lake City, FL - 32055,

Run: 25.40 S Apr 17 2026 Print: 25.40 S Apr 17 2026 MiTek Industries, Inc. Wed May 20 15:14:30  
ID:sn5jxlp07u9nXOmQVqhJiYzEcpT-RfC?PsB70Hq3NSgPqnL8w3ulTXbGkWrCdoi7J4zJC?f

Page: 1

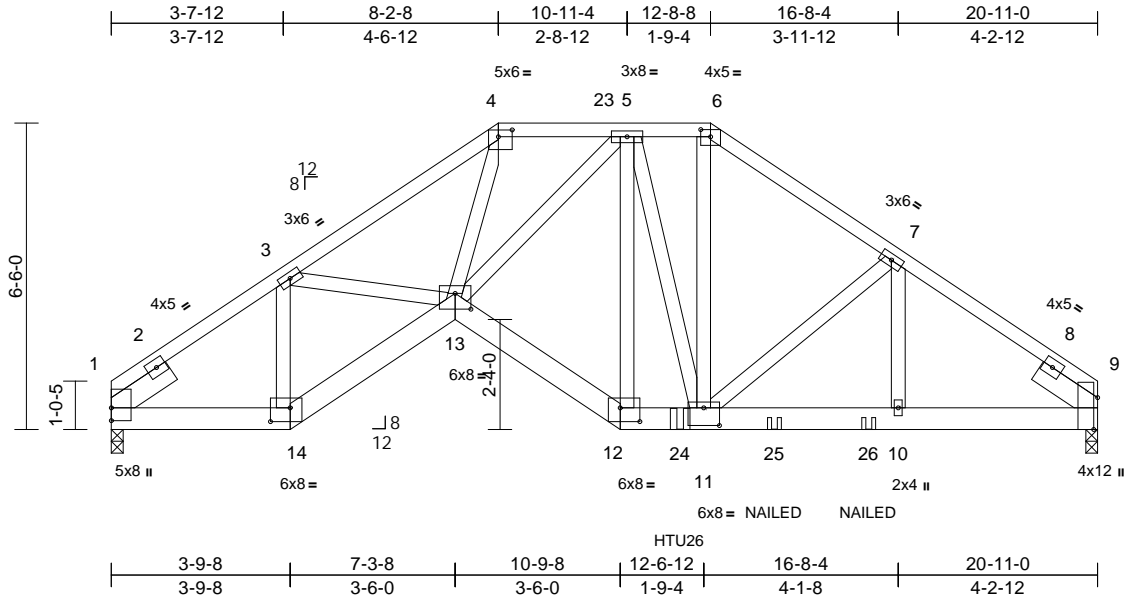

Scale = 1:48.9

Plate Offsets (X, Y): [4:0-3-8,0-1-12], [6:0-2-8,0-1-13], [9:0-8-2,Edge], [11:0-4-0,0-4-8], [12:0-5-0,0-3-8], [13:0-4-0,0-4-0], [14:0-5-0,0-3-8]

Loading	(psf)	Spacing	2-0-0	CSI	DEFL	in	(loc)	l/defl	L/d	PLATES	GRIP	
TCLL (roof)	20.0	Plate Grip DOL	1.25	TC	0.62	Vert(LL)	0.09	10-11	>999	240	MT20	244/190
TCDL	10.0	Lumber DOL	1.25	BC	0.83	Vert(CT)	-0.15	13	>999	180		
BCLL	0.0*	Rep Stress Incr	NO	WB	0.53	Horz(CT)	0.09	9	n/a	n/a		
BCDL	10.0	Code	FBC2023/TPI2014	Matrix-MS							Weight: 156 lb	FT = 20%

**LUMBER**  
TOP CHORD 2x4 SP No.2  
BOT CHORD 2x6 SP No.2  
WEBS 2x4 SP No.3  
SLIDER Left 2x6 SP No.2 -- 1-6-0, Right 2x6 SP No.2 -- 1-6-0

**BRACING**  
TOP CHORD Structural wood sheathing directly applied.  
BOT CHORD Rigid ceiling directly applied or 8-6-13 oc bracing.

**REACTIONS** (size) 1=0-3-0, 9=0-3-0  
Max Horiz 1=-136 (LC 6)  
Max Uplift 1=-432 (LC 8), 9=-644 (LC 9)  
Max Grav 1=1241 (LC 1), 9=1521 (LC 1)

**FORCES** (lb) - Maximum Compression/Maximum Tension  
TOP CHORD 1-3=-1633/602, 3-4=-2698/1044, 4-5=-1879/803, 5-6=-1494/730, 6-7=-1825/817, 7-9=-2030/916  
BOT CHORD 1-14=-529/1300, 13-14=-622/1535, 12-13=-634/1721, 11-12=-535/1443, 10-11=-681/1617, 9-10=-681/1617  
WEBS 3-14=-936/413, 3-13=-330/938, 4-13=-467/1255, 5-13=-223/663, 5-12=-738/322, 5-11=-259/355, 6-11=-380/774, 7-11=-273/223, 7-10=-106/165

**NOTES**  
1) Unbalanced roof live loads have been considered for this design.  
2) Designed to ASCE 7-22 basic load combinations for allowable stress design unless otherwise noted.  
3) Wind: ASCE 7-22; Vult=130mph (3-second gust) Vasd=101mph; TC DL=4.2psf; BC DL=3.0psf; h=18ft; Cat. II; Exp B; Enclosed; MWFRS (envelope) exterior (2) zone; end vertical left and right exposed; Lumber DOL=1.60 plate grip DOL=1.60

- Building Designer / Project engineer responsible for verifying applied roof live load shown covers rain loading requirements specific to the use of this truss component.
- Provide adequate drainage to prevent water ponding.
- This truss has been designed for a 10.0 psf bottom chord live load nonconcurrent with any other live loads.
- \* This truss has been designed for a live load of 20.0psf on the bottom chord in all areas where a rectangle 3-06-00 tall by 2-00-00 wide will fit between the bottom chord and any other members.
- Provide mechanical connection (by others) of truss to bearing plate capable of withstanding 432 lb uplift at joint 1 and 644 lb uplift at joint 9.
- Use Simpson Strong-Tie HTU26 (20-16d Girder, 11-10dx1 1/2 Truss, Single Ply Girder) or equivalent at 12-1-4 from the left end to connect truss(es) to back face of bottom chord.
- Fill all nail holes where hanger is in contact with lumber.
- "NAILED" indicates 3-10d (0.148"x3") or 3-12d (0.148"x3.25") toe-nails per NDS guidelines.
- In the LOAD CASE(S) section, loads applied to the face of the truss are noted as front (F) or back (B).

**LOAD CASE(S)** Standard  
1) Dead + Roof Live (balanced): Lumber Increase=1.25, Plate Increase=1.25  
Uniform Loads (lb/ft)  
Vert: 1-4=-60, 4-6=-60, 6-9=-60, 14-15=-20, 13-14=-20, 12-13=-20, 12-19=-20  
Concentrated Loads (lb)  
Vert: 24=-716 (B), 25=-151 (B), 26=-221 (B)

This item has been digitally signed and sealed by O'Regan, Philip, PE on the date indicated here. Printed copies of this document are not considered signed and sealed and the signature must be verified on any electronic copies.

Philip J. O'Regan PE No.58126  
MiTek Inc. DBA MiTek USA FL Cert 6634  
16023 Swingley Ridge Rd. Chesterfield, MO 63017  
Date:

May 22, 2026

**WARNING - Verify design parameters and READ NOTES ON THIS AND INCLUDED MITEK REFERENCE PAGE MII-7473 rev. 1/2/2023 BEFORE USE.**

Design valid for use only with MiTek® connectors. This design is based only upon parameters shown, and is for an individual building component, not a truss system. Before use, the building designer must verify the applicability of design parameters and properly incorporate this design into the overall building design. Bracing indicated is to prevent buckling of individual truss web and/or chord members only. Additional temporary and permanent bracing is always required for stability and to prevent collapse with possible personal injury and property damage. For general guidance regarding the fabrication, storage, delivery, erection and bracing of trusses and truss systems, see **ANSI/TPI1 Quality Criteria and DSB-22** available from Truss Plate Institute (www.tpinst.org) and **BCSI Building Component Safety Information** available from the Structural Building Component Association (www.sbcsccomponents.com)

**MiTek®**  
16023 Swingley Ridge Rd.  
Chesterfield, MO 63017  
314.434.1200 / MiTek-US.com

Job 5449020	Truss T11	Truss Type Roof Special	Qty 4	Ply 1	Job Reference (optional) T41274303
----------------	--------------	----------------------------	----------	----------	---------------------------------------

Builders FirstSource (Lake City,FL), Lake City, FL - 32055,

Run: 25.40 S Apr 17 2026 Print: 25.4.0 S Apr 17 2026 MiTek Industries, Inc. Wed May 20 15:14:30  
ID:Os3mlm?2MoAWSr\_uRBz3xwzEcpd-RfC?PsB70Hq3NSgPqnL8w3uITXbGKwRCDoi7J4zJC?f

Page: 1

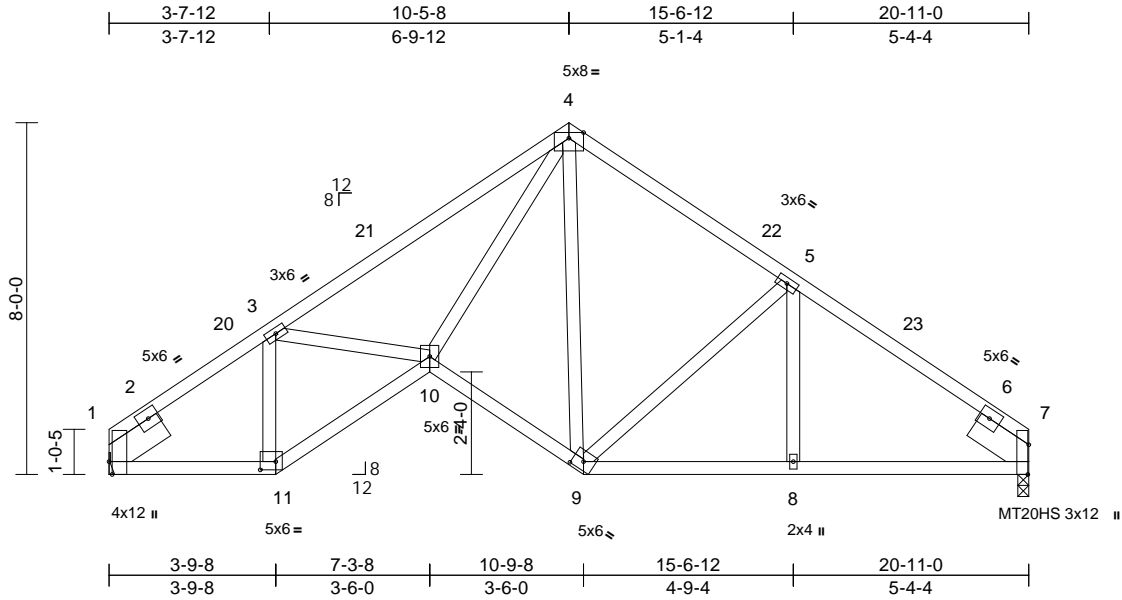

Scale = 1:52.4  
Plate Offsets (X, Y): [1:0-3-8,Edge], [7:0-8-2,Edge], [9:0-3-0,0-2-3], [11:0-4-4,0-2-4]

Loading	(psf)	Spacing	2-0-0	CSI	DEFL	in	(loc)	l/defl	L/d	PLATES	GRIP	
TCLL (roof)	20.0	Plate Grip DOL	1.25	TC	0.83	Vert(LL)	-0.07	10-11	>999	240	MT20	244/190
TCDL	10.0	Lumber DOL	1.25	BC	0.72	Vert(CT)	-0.13	10-11	>999	180	MT20HS	187/143
BCLL	0.0*	Rep Stress Incr	YES	WB	0.42	Horz(CT)	0.08	7	n/a	n/a		
BCDL	10.0	Code	FBC2023/TPI2014	Matrix-MS								Weight: 125 lb FT = 20%

- LUMBER**
- TOP CHORD 2x4 SP No.2
  - BOT CHORD 2x4 SP No.2
  - WEBS 2x4 SP No.3
  - SLIDER Left 2x8 SP 2400F 2.0E -- 1-6-0, Right 2x8 SP 2400F 2.0E -- 1-6-0

- BRACING**
- TOP CHORD Structural wood sheathing directly applied.
  - BOT CHORD Rigid ceiling directly applied or 10-0-0 oc bracing.

- REACTIONS** (size) 1= Mechanical, 7=0-3-0
- Max Horiz 1=-172 (LC 8)
  - Max Uplift 1=-186 (LC 12), 7=-186 (LC 13)
  - Max Grav 1=837 (LC 1), 7=837 (LC 1)

- FORCES** (lb) - Maximum Compression/Maximum Tension
- TOP CHORD 1-3=-1066/262, 3-4=-1528/380, 4-5=-801/250, 5-7=-1044/241
  - BOT CHORD 1-11=-293/890, 10-11=-348/1061, 9-10=-111/743, 8-9=-128/795, 7-8=-128/795
  - WEBS 3-11=-598/237, 3-10=0/368, 4-10=-282/1152, 4-9=-204/105, 5-9=-315/200, 5-8=0/167

- NOTES**
- Unbalanced roof live loads have been considered for this design.
  - Designed to ASCE 7-22 basic load combinations for allowable stress design unless otherwise noted.
  - Wind: ASCE 7-22; Vult=130mph (3-second gust) Vasd=101mph; TC DL=4.2psf; BC DL=3.0psf; h=18ft; Cat. II; Exp B; Enclosed; MWFRS (envelope) exterior (2) zone and C-C Zone3 0-0-8 to 3-0-8, Zone1 3-0-8 to 10-6-0, Zone2 10-6-0 to 14-8-15, Zone1 14-8-15 to 20-11-8 zone;C-C for members and forces & MWFRS for reactions shown; Lumber DOL=1.60 plate grip DOL=1.60
  - Building Designer / Project engineer responsible for verifying applied roof live load shown covers rain loading requirements specific to the use of this truss component.
  - All plates are MT20 plates unless otherwise indicated.

- This truss has been designed for a 10.0 psf bottom chord live load nonconcurrent with any other live loads.
- \* This truss has been designed for a live load of 20.0psf on the bottom chord in all areas where a rectangle 3-06-00 tall by 2-00-00 wide will fit between the bottom chord and any other members.
- Refer to girder(s) for truss to truss connections.
- Provide mechanical connection (by others) of truss to bearing plate capable of withstanding 186 lb uplift at joint 1 and 186 lb uplift at joint 7.

**LOAD CASE(S)** Standard

This item has been digitally signed and sealed by O'Regan, Philip, PE on the date indicated here. Printed copies of this document are not considered signed and sealed and the signature must be verified on any electronic copies.

Philip J. O'Regan PE No.58126  
MiTek Inc. DBA MiTek USA FL Cert 6634  
16023 Swingley Ridge Rd. Chesterfield, MO 63017  
Date:

May 22,2026

<p><b>WARNING - Verify design parameters and READ NOTES ON THIS AND INCLUDED MITEK REFERENCE PAGE MII-7473 rev. 1/2/2023 BEFORE USE.</b></p> <p>Design valid for use only with MiTek® connectors. This design is based only upon parameters shown, and is for an individual building component, not a truss system. Before use, the building designer must verify the applicability of design parameters and properly incorporate this design into the overall building design. Bracing indicated is to prevent buckling of individual truss web and/or chord members only. Additional temporary and permanent bracing is always required for stability and to prevent collapse with possible personal injury and property damage. For general guidance regarding the fabrication, storage, delivery, erection and bracing of trusses and truss systems, see <b>ANSI/TPI1 Quality Criteria and DSB-22</b> available from Truss Plate Institute (www.tpinst.org) and <b>BCSI Building Component Safety Information</b> available from the Structural Building Component Association (www.sbcsccomponents.com)</p>	 <p>16023 Swingley Ridge Rd. Chesterfield, MO 63017 314.434.1200 / MiTek-US.com</p>
------------------------------------------------------------------------------------------------------------------------------------------------------------------------------------------------------------------------------------------------------------------------------------------------------------------------------------------------------------------------------------------------------------------------------------------------------------------------------------------------------------------------------------------------------------------------------------------------------------------------------------------------------------------------------------------------------------------------------------------------------------------------------------------------------------------------------------------------------------------------------------------------------------------------------------------------------------------------------------------------------------------------------------------------------------------------------------------------------------------	----------------------------------------------------------------------------------------------------------------------------------------------------------------------------------



Job 5449020	Truss T12G	Truss Type Roof Special Structural Gable	Qty 1	Ply 1	Job Reference (optional) T41274305
----------------	---------------	---------------------------------------------	----------	----------	---------------------------------------

Builders FirstSource (Lake City,FL), Lake City, FL - 32055,

Run: 25.40 S Apr 17 2026 Print: 25.4.0 S Apr 17 2026 MiTek Industries, Inc. Wed May 20 15:14:30

Page: 1

ID:RsnSTCIPsr3G\_s1vLL6gj\_zEcrF-RfC?PsB70Hq3NSgPqnL8w3uITXbGKwRCDoi7J4zJC?f

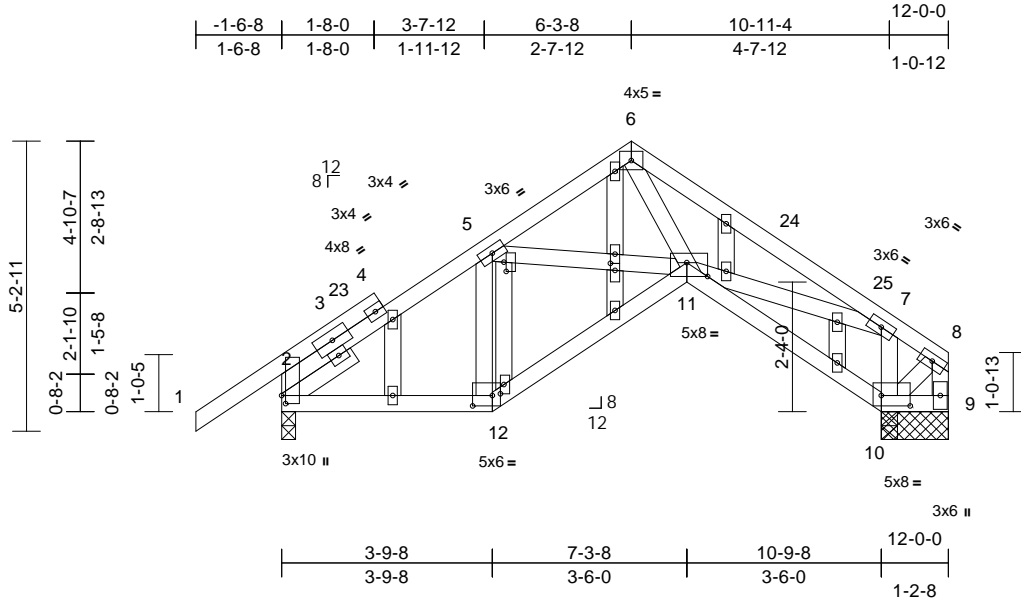

Scale = 1:41.5

Plate Offsets (X, Y): [2:0-1-12,0-0-14], [10:0-6-4,0-2-4], [11:0-4-8,Edge], [12:0-4-4,0-2-4], [14:0-2-0,0-0-12], [15:0-2-0,0-0-8], [16:0-1-8,0-1-0]

Loading	(psf)	Spacing	2-0-0	CSI	DEFL	in	(loc)	l/defl	L/d	PLATES	GRIP	
TCLL (roof)	20.0	Plate Grip DOL	1.25	TC	0.31	Vert(LL)	-0.01	11-12	>999	240	MT20	244/190
TCDL	10.0	Lumber DOL	1.25	BC	0.15	Vert(CT)	-0.03	11-12	>999	180		
BCLL	0.0*	Rep Stress Incr	YES	WB	0.26	Horz(CT)	0.02	10	n/a	n/a		
BCDL	10.0	Code	FBC2023/TPI2014	Matrix-MS							Weight: 84 lb	FT = 20%

**LUMBER**  
TOP CHORD 2x4 SP No.2  
BOT CHORD 2x4 SP No.2  
WEBS 2x4 SP No.3  
OTHERS 2x4 SP No.3  
SLIDER Left 2x4 SP No.3 -- 1-6-0

**BRACING**  
TOP CHORD Structural wood sheathing directly applied, except end verticals.  
BOT CHORD Rigid ceiling directly applied or 6-0-0 oc bracing.

**REACTIONS**  
(size) 2=0-3-0, 9=1-2-8, 10=1-2-8  
Max Horiz 2=113 (LC 9)  
Max Uplift 2=-134 (LC 12), 9=-423 (LC 1), 10=-195 (LC 12)  
Max Grav 2=487 (LC 1), 9=97 (LC 12), 10=975 (LC 1)

**FORCES** (lb) - Maximum Compression/Maximum Tension  
TOP CHORD 8-9=-125/403, 1-2=0/40, 2-5=-439/143, 5-6=-382/113, 6-7=-563/105, 7-8=-88/348  
BOT CHORD 2-12=-92/333, 11-12=-109/398, 10-11=-342/77, 9-10=-29/17  
WEBS 5-12=-177/86, 5-11=-83/107, 6-11=-30/313, 7-11=-79/694, 7-10=-577/297, 8-10=-245/38

**NOTES**  
1) Unbalanced roof live loads have been considered for this design.  
2) Designed to ASCE 7-22 basic load combinations for allowable stress design unless otherwise noted.  
3) Wind: ASCE 7-22; Vult=130mph (3-second gust) Vasd=101mph; TC DL=4.2psf; BCDL=3.0psf; h=18ft; Cat. II; Exp B; Enclosed; MWFRS (envelope) exterior (2) zone and C-C Zone3 -1-6-8 to 1-5-8, Zone1 1-5-8 to 6-3-8, Zone2 6-3-8 to 10-6-7, Zone1 10-6-7 to 11-10-4 zone; end vertical left exposed;C-C for members and forces & MWFRS for reactions shown; Lumber DOL=1.60 plate grip DOL=1.60

- Truss designed for wind loads in the plane of the truss only. For studs exposed to wind (normal to the face), see Standard Industry Gable End Details as applicable, or consult qualified building designer as per ANSI/TPI 1.
- Building Designer / Project engineer responsible for verifying applied roof live load shown covers rain loading requirements specific to the use of this truss component.
- All plates are 2x4 (||) MT20 unless otherwise indicated.
- Gable studs spaced at 2-0-0 oc.
- This truss has been designed for a 10.0 psf bottom chord live load nonconcurrent with any other live loads.
- \* This truss has been designed for a live load of 20.0psf on the bottom chord in all areas where a rectangle 3-06-00 tall by 2-00-00 wide will fit between the bottom chord and any other members.
- Provide mechanical connection (by others) of truss to bearing plate capable of withstanding 134 lb uplift at joint 2, 195 lb uplift at joint 10 and 423 lb uplift at joint 9.

**LOAD CASE(S)** Standard

This item has been digitally signed and sealed by O'Regan, Philip, PE on the date indicated here. Printed copies of this document are not considered signed and sealed and the signature must be verified on any electronic copies.

Philip J. O'Regan PE No.58126  
MiTek Inc. DBA MiTek USA FL Cert 6634  
16023 Swingley Ridge Rd. Chesterfield, MO 63017  
Date:

May 22,2026

**WARNING - Verify design parameters and READ NOTES ON THIS AND INCLUDED MITEK REFERENCE PAGE MII-7473 rev. 1/2/2023 BEFORE USE.**

Design valid for use only with MiTek® connectors. This design is based only upon parameters shown, and is for an individual building component, not a truss system. Before use, the building designer must verify the applicability of design parameters and properly incorporate this design into the overall building design. Bracing indicated is to prevent buckling of individual truss web and/or chord members only. Additional temporary and permanent bracing is always required for stability and to prevent collapse with possible personal injury and property damage. For general guidance regarding the fabrication, storage, delivery, erection and bracing of trusses and truss systems, see **ANSI/TPI1 Quality Criteria and DSB-22** available from Truss Plate Institute (www.tpinst.org) and **BCSI Building Component Safety Information** available from the Structural Building Component Association (www.sbcsccomponents.com)

**MiTek®**  
16023 Swingley Ridge Rd.  
Chesterfield, MO 63017  
314.434.1200 / MiTek-US.com

Job 5449020	Truss T13	Truss Type Half Hip Girder	Qty 1	Ply 1	Job Reference (optional) T41274306
----------------	--------------	-------------------------------	----------	----------	---------------------------------------

Builders FirstSource (Lake City,FL), Lake City, FL - 32055,

Run: 25.40 S Apr 17 2026 Print: 25.4.0 S Apr 17 2026 MiTek Industries, Inc. Wed May 20 15:14:31  
ID:B2dLtpW\_BNCE1f6KgDc6IzEcsS-RfC?PsB70Hq3NSgPqnL8w3uITXbGKWrCDoi7J4zJC?f

Page: 1

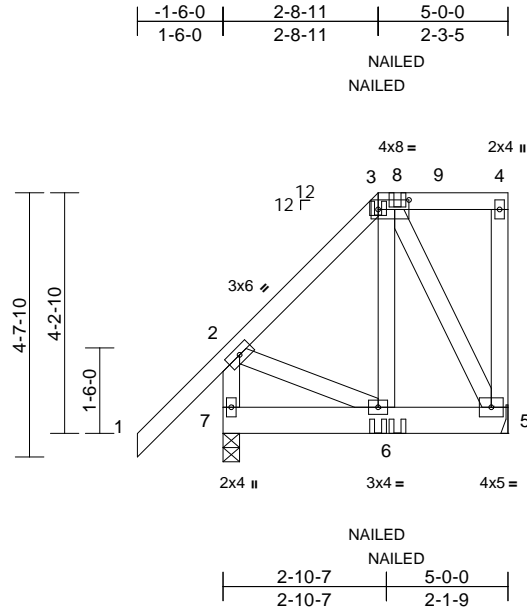

Scale = 1:40.4

Plate Offsets (X, Y): [3:0-6-8,0-2-0]

Loading	(psf)	Spacing	2-0-0	CSI	DEFL	in	(loc)	l/defl	L/d	PLATES	GRIP	
TCLL (roof)	20.0	Plate Grip DOL	1.25	TC	0.21	Vert(LL)	0.00	6	>999	240	MT20	244/190
TCDL	10.0	Lumber DOL	1.25	BC	0.03	Vert(CT)	0.00	6-7	>999	180		
BCLL	0.0*	Rep Stress Incr	NO	WB	0.08	Horz(CT)	0.00	5	n/a	n/a		
BCDL	10.0	Code	FBC2023/TPI2014	Matrix-MP							Weight: 46 lb	FT = 20%

**LUMBER**

TOP CHORD 2x4 SP No.2  
BOT CHORD 2x6 SP No.2  
WEBS 2x4 SP No.3

**BRACING**

TOP CHORD Structural wood sheathing directly applied, except end verticals.  
BOT CHORD Rigid ceiling directly applied or 10-0-0 oc bracing.

**REACTIONS**

(size) 5= Mechanical, 7=0-3-8  
Max Horiz 7=140 (LC 8)  
Max Uplift 5=-193 (LC 8), 7=-116 (LC 8)  
Max Grav 5=276 (LC 15), 7=359 (LC 15)

**FORCES**

(lb) - Maximum Compression/Maximum Tension  
TOP CHORD 1-2=0/70, 2-3=-207/92, 3-4=0/0, 4-5=-75/46, 2-7=-329/117  
BOT CHORD 6-7=-148/67, 5-6=-88/114  
WEBS 3-6=-68/157, 3-5=-234/182, 2-6=-71/221

**NOTES**

- 1) Unbalanced roof live loads have been considered for this design.
- 2) Designed to ASCE 7-22 basic load combinations for allowable stress design unless otherwise noted.
- 3) Wind: ASCE 7-22; Vult=130mph (3-second gust) Vasd=101mph; TC DL=4.2psf; BCDL=3.0psf; h=18ft; Cat. II; Exp B; Enclosed; MWFRS (envelope) exterior (2) zone; end vertical left exposed; Lumber DOL=1.60 plate grip DOL=1.60
- 4) Building Designer / Project engineer responsible for verifying applied roof live load shown covers rain loading requirements specific to the use of this truss component.
- 5) Provide adequate drainage to prevent water ponding.
- 6) This truss has been designed for a 10.0 psf bottom chord live load nonconcurrent with any other live loads.

- 7) \* This truss has been designed for a live load of 20.0psf on the bottom chord in all areas where a rectangle 3-06-00 tall by 2-00-00 wide will fit between the bottom chord and any other members.
- 8) Refer to girder(s) for truss to truss connections.
- 9) Provide mechanical connection (by others) of truss to bearing plate capable of withstanding 116 lb uplift at joint 7 and 193 lb uplift at joint 5.
- 10) "NAILED" indicates 3-10d (0.148"x3") or 2-12d (0.148"x3.25") toe-nails per NDS guidelines.
- 11) In the LOAD CASE(S) section, loads applied to the face of the truss are noted as front (F) or back (B).

**LOAD CASE(S)** Standard

- 1) Dead + Roof Live (balanced): Lumber Increase=1.25, Plate Increase=1.25  
Uniform Loads (lb/ft)  
Vert: 1-2=-60, 2-3=-60, 3-4=-60, 5-7=-20  
Concentrated Loads (lb)  
Vert: 3=-3 (B), 6=-48 (B), 8=-58 (B)

This item has been digitally signed and sealed by ORegan, Philip, PE on the date indicated here. Printed copies of this document are not considered signed and sealed and the signature must be verified on any electronic copies.

Philip J. O'Regan PE No.58126  
MiTek Inc. DBA MiTek USA FL Cert 6634  
16023 Swingley Ridge Rd. Chesterfield, MO 63017  
Date:

May 22, 2026

**WARNING - Verify design parameters and READ NOTES ON THIS AND INCLUDED MITEK REFERENCE PAGE MII-7473 rev. 1/2/2023 BEFORE USE.**

Design valid for use only with MiTek® connectors. This design is based only upon parameters shown, and is for an individual building component, not a truss system. Before use, the building designer must verify the applicability of design parameters and properly incorporate this design into the overall building design. Bracing indicated is to prevent buckling of individual truss web and/or chord members only. Additional temporary and permanent bracing is always required for stability and to prevent collapse with possible personal injury and property damage. For general guidance regarding the fabrication, storage, delivery, erection and bracing of trusses and truss systems, see **ANSI/TPI1 Quality Criteria and DSB-22** available from Truss Plate Institute (www.tpinst.org) and **BCSI Building Component Safety Information** available from the Structural Building Component Association (www.sbcsccomponents.com)

**MiTek®**

16023 Swingley Ridge Rd.  
Chesterfield, MO 63017  
314.434.1200 / MiTek-US.com

Job 5449020	Truss T14	Truss Type Half Hip	Qty 1	Ply 1	Job Reference (optional) T41274307
----------------	--------------	------------------------	----------	----------	---------------------------------------

Builders FirstSource (Lake City,FL), Lake City, FL - 32055,

Run: 25.40 S Apr 17 2026 Print: 25.4.0 S Apr 17 2026 MiTek Industries, Inc. Wed May 20 15:14:31

Page: 1

ID:rMMtq\_y29ttVhtZQ1CRRbHzEcsG-RfC?PsB70Hq3NSgPqnL8w3uITxbGKWrCDoi7J4zJC?f

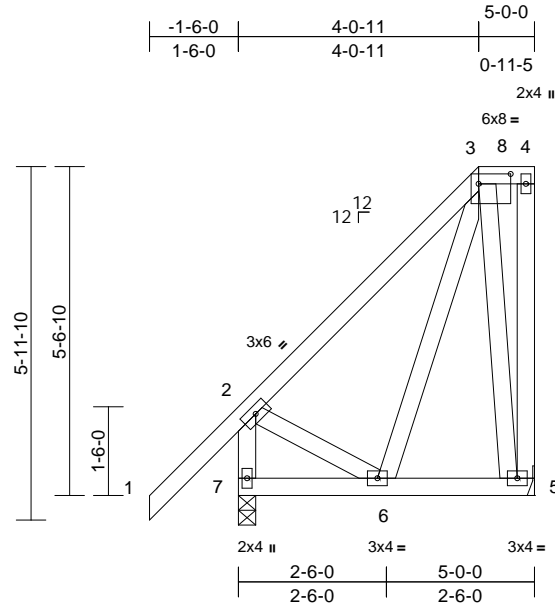

Scale = 1:38.9

Plate Offsets (X, Y): [3:0-6-8,0-2-0]

Loading	(psf)	Spacing	2-0-0	CSI	DEFL	in	(loc)	l/defl	L/d	PLATES	GRIP	
TCLL (roof)	20.0	Plate Grip DOL	1.25	TC	0.35	Vert(LL)	0.00	5-6	>999	240	MT20	244/190
TCDL	10.0	Lumber DOL	1.25	BC	0.05	Vert(CT)	0.00	5-6	>999	180		
BCLL	0.0*	Rep Stress Incr	YES	WB	0.12	Horz(CT)	0.00	5	n/a	n/a		
BCDL	10.0	Code	FBC2023/TPI2014	Matrix-MP							Weight: 48 lb	FT = 20%

**LUMBER**

TOP CHORD 2x4 SP No.2  
 BOT CHORD 2x4 SP No.2  
 WEBS 2x4 SP No.3

**BRACING**

TOP CHORD Structural wood sheathing directly applied, except end verticals.  
 BOT CHORD Rigid ceiling directly applied or 10-0-0 oc bracing.

**REACTIONS**

(size) 5= Mechanical, 7=0-3-8  
 Max Horiz 7=191 (LC 12)  
 Max Uplift 5=-153 (LC 12)  
 Max Grav 5=184 (LC 19), 7=304 (LC 1)

**FORCES**

(lb) - Maximum Compression/Maximum Tension

TOP CHORD 1-2=0/70, 2-3=-143/37, 3-4=0/0, 4-5=-24/24, 2-7=-286/58  
 BOT CHORD 6-7=-272/152, 5-6=-30/33  
 WEBS 3-6=-104/110, 3-5=-220/198, 2-6=-103/245

**NOTES**

- 1) Unbalanced roof live loads have been considered for this design.
- 2) Designed to ASCE 7-22 basic load combinations for allowable stress design unless otherwise noted.
- 3) Wind: ASCE 7-22; Vult=130mph (3-second gust) Vasd=101mph; TC DL=4.2psf; BCDL=3.0psf; h=18ft; Cat. II; Exp B; Enclosed; MWFRS (envelope) exterior (2) zone and C-C Zone1 -1-6-0 to 4-0-11, Zone3 4-0-11 to 4-10-4 zone; end vertical left exposed; C-C for members and forces & MWFRS for reactions shown; Lumber DOL=1.60 plate grip DOL=1.60
- 4) Building Designer / Project engineer responsible for verifying applied roof live load shown covers rain loading requirements specific to the use of this truss component.
- 5) Provide adequate drainage to prevent water ponding.
- 6) This truss has been designed for a 10.0 psf bottom chord live load nonconcurrent with any other live loads.

- 7) \* This truss has been designed for a live load of 20.0psf on the bottom chord in all areas where a rectangle 3-06-00 tall by 2-00-00 wide will fit between the bottom chord and any other members.
- 8) Refer to girder(s) for truss to truss connections.
- 9) Provide mechanical connection (by others) of truss to bearing plate capable of withstanding 153 lb uplift at joint 5.

**LOAD CASE(S)** Standard

This item has been digitally signed and sealed by ORegan, Philip, PE on the date indicated here. Printed copies of this document are not considered signed and sealed and the signature must be verified on any electronic copies.

Philip J. O'Regan PE No.58126  
 MiTek Inc. DBA MiTek USA FL Cert 6634  
 16023 Swingley Ridge Rd. Chesterfield, MO 63017  
 Date:

May 22, 2026

**WARNING - Verify design parameters and READ NOTES ON THIS AND INCLUDED MITEK REFERENCE PAGE MII-7473 rev. 1/2/2023 BEFORE USE.**

Design valid for use only with MiTek® connectors. This design is based only upon parameters shown, and is for an individual building component, not a truss system. Before use, the building designer must verify the applicability of design parameters and properly incorporate this design into the overall building design. Bracing indicated is to prevent buckling of individual truss web and/or chord members only. Additional temporary and permanent bracing is always required for stability and to prevent collapse with possible personal injury and property damage. For general guidance regarding the fabrication, storage, delivery, erection and bracing of trusses and truss systems, see **ANSI/TPI1 Quality Criteria and DSB-22** available from Truss Plate Institute (www.tpinst.org) and **BCSI Building Component Safety Information** available from the Structural Building Component Association (www.sbcsccomponents.com)

**MiTek®**

16023 Swingley Ridge Rd.  
 Chesterfield, MO 63017  
 314.434.1200 / MiTek-US.com

Job 5449020	Truss T15	Truss Type Jack-Closed Girder	Qty 1	Ply 1	Job Reference (optional) T41274308
----------------	--------------	----------------------------------	----------	----------	---------------------------------------

Builders FirstSource (Lake City,FL), Lake City, FL - 32055,

Run: 25.40 S Apr 17 2026 Print: 25.4.0 S Apr 17 2026 MiTek Industries, Inc. Wed May 20 15:14:31  
ID:k0HNne1SBCgN2xnT3kX8H4DzEqL-RfC?PsB70Hq3NSgPqnL8w3uTXbGKWrcDoi7J4zJC?f

Page: 1

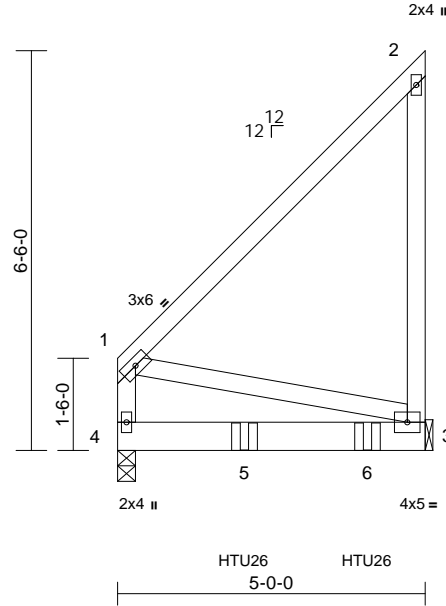

Scale = 1:37.4

Loading	(psf)	Spacing	2-0-0	CSI	DEFL	in	(loc)	l/defl	L/d	PLATES	GRIP	
TCLL (roof)	20.0	Plate Grip DOL	1.25	TC	0.48	Vert(LL)	-0.04	3-4	>999	240	MT20	244/190
TCDL	10.0	Lumber DOL	1.25	BC	0.78	Vert(CT)	-0.09	3-4	>631	180		
BCLL	0.0*	Rep Stress Incr	NO	WB	0.05	Horz(CT)	0.00	3	n/a	n/a		
BCDL	10.0	Code	FBC2023/TPI2014	Matrix-MP							Weight: 39 lb	FT = 20%

#### LUMBER

TOP CHORD 2x4 SP No.2  
BOT CHORD 2x6 SP No.2  
WEBS 2x4 SP No.3

#### BRACING

TOP CHORD Structural wood sheathing directly applied, except end verticals.  
BOT CHORD Rigid ceiling directly applied or 9-11-1 oc bracing.

#### REACTIONS (size)

3= Mechanical, 4=0-3-8  
Max Horiz 4=166 (LC 8)  
Max Uplift 3=-323 (LC 8), 4=-51 (LC 4)  
Max Grav 3=736 (LC 1), 4=524 (LC 1)

#### FORCES (lb) - Maximum Compression/Maximum Tension

TOP CHORD 1-4=-141/0, 1-2=-140/101, 2-3=-167/162  
BOT CHORD 3-4=-174/79  
WEBS 1-3=-82/179

#### NOTES

- Unbalanced roof live loads have been considered for this design.
- Designed to ASCE 7-22 basic load combinations for allowable stress design unless otherwise noted.
- Wind: ASCE 7-22; Vult=130mph (3-second gust)  
Vasd=101mph; TCDL=4.2psf; BCDL=3.0psf; h=18ft; Cat. II; Exp B; Enclosed; MWFRS (envelope) interior (1) zone; end vertical left exposed; Lumber DOL=1.60 plate grip DOL=1.60
- Building Designer / Project engineer responsible for verifying applied roof live load shown covers rain loading requirements specific to the use of this truss component.
- This truss has been designed for a 10.0 psf bottom chord live load nonconcurrent with any other live loads.
- \* This truss has been designed for a live load of 20.0psf on the bottom chord in all areas where a rectangle 3-06-00 tall by 2-00-00 wide will fit between the bottom chord and any other members.
- Refer to girder(s) for truss to truss connections.

- Provide mechanical connection (by others) of truss to bearing plate capable of withstanding 51 lb uplift at joint 4 and 323 lb uplift at joint 3.
- Use Simpson Strong-Tie HTU26 (20-16d Girder, 11-10dx1 1/2 Truss, Single Ply Girder) or equivalent spaced at 2-0-0 oc max. starting at 2-0-12 from the left end to 4-0-12 to connect truss(es) to front face of bottom chord.
- Fill all nail holes where hanger is in contact with lumber.
- In the LOAD CASE(S) section, loads applied to the face of the truss are noted as front (F) or back (B).

#### LOAD CASE(S) Standard

- Dead + Roof Live (balanced): Lumber Increase=1.25, Plate Increase=1.25  
Uniform Loads (lb/ft)  
Vert: 1-2=-60, 3-4=-20  
Concentrated Loads (lb)  
Vert: 5=-441 (F), 6=-443 (F)

This item has been digitally signed and sealed by ORegan, Philip, PE on the date indicated here. Printed copies of this document are not considered signed and sealed and the signature must be verified on any electronic copies.

Philip J. O'Regan PE No.58126  
MiTek Inc. DBA MiTek USA FL Cert 6634  
16023 Swingley Ridge Rd. Chesterfield, MO 63017  
Date:

May 22, 2026

#### WARNING - Verify design parameters and READ NOTES ON THIS AND INCLUDED MITEK REFERENCE PAGE MII-7473 rev. 1/2/2023 BEFORE USE.

Design valid for use only with MiTek® connectors. This design is based only upon parameters shown, and is for an individual building component, not a truss system. Before use, the building designer must verify the applicability of design parameters and properly incorporate this design into the overall building design. Bracing indicated is to prevent buckling of individual truss web and/or chord members only. Additional temporary and permanent bracing is always required for stability and to prevent collapse with possible personal injury and property damage. For general guidance regarding the fabrication, storage, delivery, erection and bracing of trusses and truss systems, see **ANSI/TPI1 Quality Criteria and DSB-22** available from Truss Plate Institute ([www.tpinst.org](http://www.tpinst.org)) and **BCSI Building Component Safety Information** available from the Structural Building Component Association ([www.sbcsccomponents.com](http://www.sbcsccomponents.com))

# MiTek®

16023 Swingley Ridge Rd.  
Chesterfield, MO 63017  
314.434.1200 / MiTek-US.com

Job 5449020	Truss T16	Truss Type Common	Qty 2	Ply 1	Job Reference (optional) T41274309
----------------	--------------	----------------------	----------	----------	---------------------------------------

Builders FirstSource (Lake City,FL), Lake City, FL - 32055,

Run: 25.40 S Apr 17 2026 Print: 25.4.0 S Apr 17 2026 MiTek Industries, Inc. Wed May 20 15:14:31  
ID:xZCN36R3a32nc\_?aLz5kjozEcnn-RfC?PsB70Hq3NSgPqnL8w3uITXbGKWRcDdoi7J4zJC?f

Page: 1

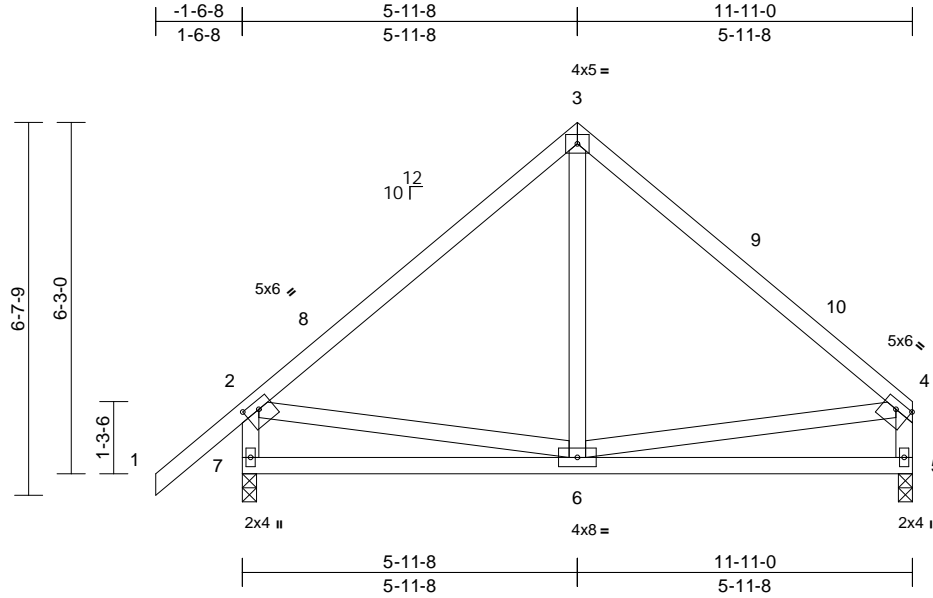

Scale = 1:41

Plate Offsets (X, Y): [2:0-3-0,0-1-12], [4:0-3-0,0-1-12]

Loading	(psf)	Spacing	2-0-0	CSI	DEFL	in	(loc)	l/defl	L/d	PLATES	GRIP	
TCLL (roof)	20.0	Plate Grip DOL	1.25	TC	0.44	Vert(LL)	-0.02	5-6	>999	240	MT20	244/190
TCDL	10.0	Lumber DOL	1.25	BC	0.30	Vert(CT)	-0.05	6-7	>999	180		
BCLL	0.0*	Rep Stress Incr	YES	WB	0.08	Horz(CT)	0.00	5	n/a	n/a		
BCDL	10.0	Code	FBC2023/TPI2014	Matrix-MS							Weight: 72 lb	FT = 20%

**LUMBER**

TOP CHORD 2x4 SP No.2  
BOT CHORD 2x4 SP No.2  
WEBS 2x4 SP No.3

**BRACING**

TOP CHORD Structural wood sheathing directly applied, except end verticals.  
BOT CHORD Rigid ceiling directly applied or 10-0-0 oc bracing.

**REACTIONS**

(size) 5=0-3-0, 7=0-3-0  
Max Horiz 7=181 (LC 9)  
Max Uplift 5=-94 (LC 13), 7=-137 (LC 12)  
Max Grav 5=458 (LC 1), 7=574 (LC 1)

**FORCES**

(lb) - Maximum Compression/Maximum Tension

TOP CHORD 1-2=0/65, 2-3=-446/164, 3-4=-437/166, 2-7=-522/284, 4-5=-406/192  
BOT CHORD 6-7=-223/263, 5-6=-110/131  
WEBS 3-6=-3/220, 2-6=-83/213, 4-6=-69/194

**NOTES**

- 1) Unbalanced roof live loads have been considered for this design.
- 2) Designed to ASCE 7-22 basic load combinations for allowable stress design unless otherwise noted.
- 3) Wind: ASCE 7-22; Vult=130mph (3-second gust) Vasd=101mph; TCDL=4.2psf; BCDL=3.0psf; h=18ft; Cat. II; Exp B; Enclosed; MWFRS (envelope) exterior (2) zone and C-C Zone3 -1-6-0 to 1-6-0, Zone1 1-6-0 to 6-0-0, Zone2 6-0-0 to 10-2-15, Zone1 10-2-15 to 11-9-12 zone; end vertical left and right exposed; C-C for members and forces & MWFRS for reactions shown; Lumber DOL=1.60 plate grip DOL=1.60
- 4) Building Designer / Project engineer responsible for verifying applied roof live load shown covers rain loading requirements specific to the use of this truss component.
- 5) This truss has been designed for a 10.0 psf bottom chord live load nonconcurrent with any other live loads.

- 6) \* This truss has been designed for a live load of 20.0psf on the bottom chord in all areas where a rectangle 3-06-00 tall by 2-00-00 wide will fit between the bottom chord and any other members.
- 7) Provide mechanical connection (by others) of truss to bearing plate at joint(s) 7.
- 8) Provide mechanical connection (by others) of truss to bearing plate capable of withstanding 137 lb uplift at joint 7 and 94 lb uplift at joint 5.

**LOAD CASE(S)** Standard

This item has been digitally signed and sealed by ORegan, Philip, PE on the date indicated here. Printed copies of this document are not considered signed and sealed and the signature must be verified on any electronic copies.

Philip J. O'Regan PE No.58126  
MiTek Inc. DBA MiTek USA FL Cert 6634  
16023 Swingley Ridge Rd. Chesterfield, MO 63017  
Date:

May 22, 2026

**WARNING - Verify design parameters and READ NOTES ON THIS AND INCLUDED MITEK REFERENCE PAGE MII-7473 rev. 1/2/2023 BEFORE USE.**

Design valid for use only with MiTek® connectors. This design is based only upon parameters shown, and is for an individual building component, not a truss system. Before use, the building designer must verify the applicability of design parameters and properly incorporate this design into the overall building design. Bracing indicated is to prevent buckling of individual truss web and/or chord members only. Additional temporary and permanent bracing is always required for stability and to prevent collapse with possible personal injury and property damage. For general guidance regarding the fabrication, storage, delivery, erection and bracing of trusses and truss systems, see **ANSI/TPI1 Quality Criteria and DSB-22** available from Truss Plate Institute (www.tpinst.org) and **BCSI Building Component Safety Information** available from the Structural Building Component Association (www.sbcsccomponents.com)

**MiTek®**

16023 Swingley Ridge Rd.  
Chesterfield, MO 63017  
314.434.1200 / MiTek-US.com

Job 5449020	Truss T16G	Truss Type Common Supported Gable	Qty 1	Ply 1	Job Reference (optional) T41274310
----------------	---------------	--------------------------------------	----------	----------	---------------------------------------

Builders FirstSource (Lake City,FL), Lake City, FL - 32055,

Run: 25.40 S Apr 17 2026 Print: 25.4.0 S Apr 17 2026 MiTek Industries, Inc. Wed May 20 15:14:31

Page: 1

ID:Rpf9ofXeHjJSKkanLkHm5ozEcjn-RfC?PsB70Hq3NSgPqnL8w3ulTXbGKwRCDoi7J4zJC?f

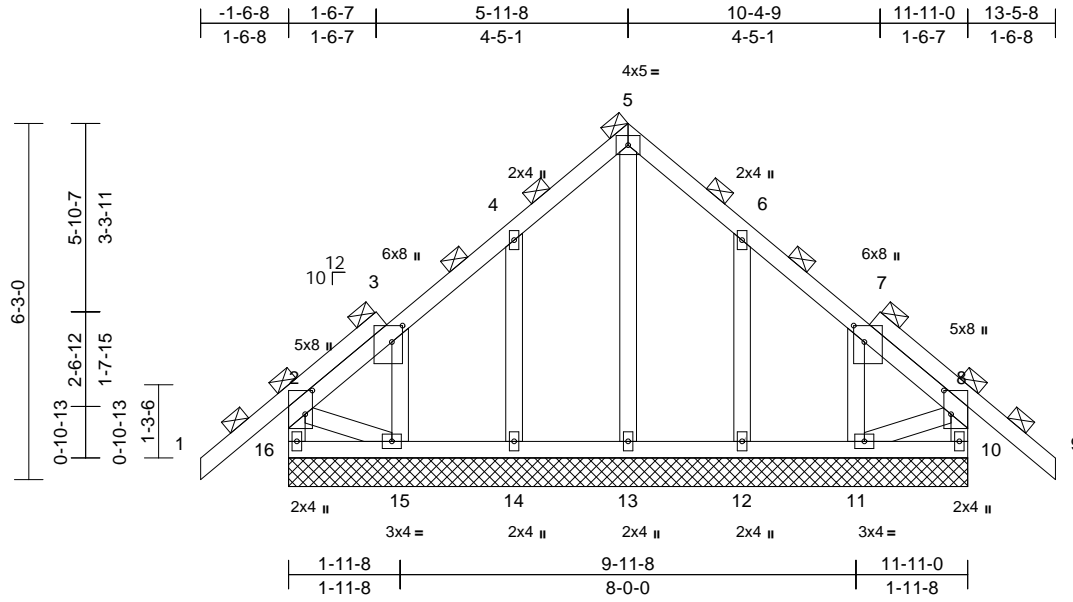

Scale = 1:40.4  
Plate Offsets (X, Y): [2:0-5-0,0-1-8], [3:0-3-7,0-2-4], [7:0-3-7,0-2-4], [8:0-5-0,0-1-8]

Loading	(psf)	Spacing	2-0-0	CSI	DEFL	in	(loc)	l/defl	L/d	PLATES	GRIP	
TCLL (roof)	20.0	Plate Grip DOL	1.25	TC	0.22	Vert(LL)	n/a	-	n/a	999	MT20	244/190
TCDL	10.0	Lumber DOL	1.25	BC	0.04	Vert(CT)	n/a	-	n/a	999		
BCLL	0.0*	Rep Stress Incr	YES	WB	0.06	Horz(CT)	0.00	10	n/a	n/a		
BCDL	10.0	Code	FBC2023/TPI2014	Matrix-MS							Weight: 85 lb	FT = 20%

**LUMBER**  
TOP CHORD 2x4 SP No.2  
BOT CHORD 2x4 SP No.2  
WEBS 2x4 SP No.3  
OTHERS 2x4 SP No.3

**BRACING**  
TOP CHORD 2-0-0 oc purlins, except end verticals.  
BOT CHORD Rigid ceiling directly applied or 6-0-0 oc bracing.

**REACTIONS** (size)  
10=11-11-0, 11=11-11-0,  
12=11-11-0, 13=11-11-0,  
14=11-11-0, 15=11-11-0,  
16=11-11-0  
Max Horiz 16=-176 (LC 10)  
Max Uplift 10=-29 (LC 9), 11=-127 (LC 13),  
12=-104 (LC 13), 14=-104 (LC 12),  
15=-133 (LC 12), 16=-60 (LC 8)  
Max Grav 10=217 (LC 1), 11=151 (LC 20),  
12=186 (LC 20), 13=148 (LC 22),  
14=185 (LC 19), 15=163 (LC 19),  
16=217 (LC 1)

**FORCES** (lb) - Maximum Compression/Maximum Tension  
TOP CHORD 2-16=-203/91, 1-2=0/58, 2-3=-107/82,  
3-4=-77/64, 4-5=-80/144, 5-6=-80/143,  
6-7=-52/45, 7-8=-89/46, 8-9=0/58,  
8-10=-203/86  
BOT CHORD 15-16=-160/148, 14-15=-77/179,  
13-14=-77/179, 12-13=-77/179,  
11-12=-77/179, 10-11=-29/42  
WEBS 5-13=-107/10, 4-14=-145/159, 3-15=-110/114,  
6-12=-146/159, 7-11=-109/114, 2-15=-83/154,  
8-11=-61/151

**NOTES**  
1) Unbalanced roof live loads have been considered for this design.  
2) Designed to ASCE 7-22 basic load combinations for allowable stress design unless otherwise noted.

- Wind: ASCE 7-22; Vult=130mph (3-second gust) Vasd=101mph; TC DL=4.2psf; BCDL=3.0psf; h=18ft; Cat. II; Exp B; Enclosed; MWFRS (envelope) exterior (2) zone and C-C Zone3 zone; end vertical left and right exposed; C-C for members and forces & MWFRS for reactions shown; Lumber DOL=1.60 plate grip DOL=1.60
- Truss designed for wind loads in the plane of the truss only. For studs exposed to wind (normal to the face), see Standard Industry Gable End Details as applicable, or consult qualified building designer as per ANSI/TPI 1.
- Building Designer / Project engineer responsible for verifying applied roof live load shown covers rain loading requirements specific to the use of this truss component.
- Gable requires continuous bottom chord bearing.
- Truss to be fully sheathed from one face or securely braced against lateral movement (i.e. diagonal web).
- Gable studs spaced at 2-0-0 oc.
- This truss has been designed for a 10.0 psf bottom chord live load nonconcurrent with any other live loads.
- \* This truss has been designed for a live load of 20.0psf on the bottom chord in all areas where a rectangle 3-06-00 tall by 2-00-00 wide will fit between the bottom chord and any other members.
- Provide mechanical connection (by others) of truss to bearing plate capable of withstanding 60 lb uplift at joint 16, 29 lb uplift at joint 10, 104 lb uplift at joint 14, 133 lb uplift at joint 15, 104 lb uplift at joint 12 and 127 lb uplift at joint 11.
- Graphical purlin representation does not depict the size or the orientation of the purlin along the top and/or bottom chord.

**LOAD CASE(S)** Standard

This item has been digitally signed and sealed by ORegan, Philip, PE on the date indicated here. Printed copies of this document are not considered signed and sealed and the signature must be verified on any electronic copies.

Philip J. O'Regan PE No.58126  
MiTek Inc. DBA MiTek USA FL Cert 6634  
16023 Swingley Ridge Rd. Chesterfield, MO 63017  
Date:

May 22, 2026

**WARNING - Verify design parameters and READ NOTES ON THIS AND INCLUDED MITEK REFERENCE PAGE MII-7473 rev. 1/2/2023 BEFORE USE.**

Design valid for use only with MiTek® connectors. This design is based only upon parameters shown, and is for an individual building component, not a truss system. Before use, the building designer must verify the applicability of the design parameters and properly incorporate this design into the overall building design. Bracing indicated is to prevent buckling of individual truss web and/or chord members only. Additional temporary and permanent bracing is always required for stability and to prevent collapse with possible personal injury and property damage. For general guidance regarding the fabrication, storage, delivery, erection and bracing of trusses and truss systems, see **ANSI/TPI1 Quality Criteria and DSB-22** available from Truss Plate Institute (www.tpinst.org) and **BCSI Building Component Safety Information** available from the Structural Building Component Association (www.sbcsccomponents.com)

**MiTek®**  
16023 Swingley Ridge Rd.  
Chesterfield, MO 63017  
314.434.1200 / MiTek-US.com

Job 5449020	Truss T17	Truss Type Roof Special	Qty 3	Ply 1	Job Reference (optional) T41274311
----------------	--------------	----------------------------	----------	----------	---------------------------------------

Builders FirstSource (Lake City,FL), Lake City, FL - 32055,

Run: 25.40 S Apr 17 2026 Print: 25.4.0 S Apr 17 2026 MiTek Industries, Inc. Wed May 20 15:14:31  
ID:ASYCaCiYu0zvw\_LNuXvzOlzEcgz-RfC?PsB70Hq3NSgPqnL8w3uITxBGKWrCDoi7J4zJC?f

Page: 1

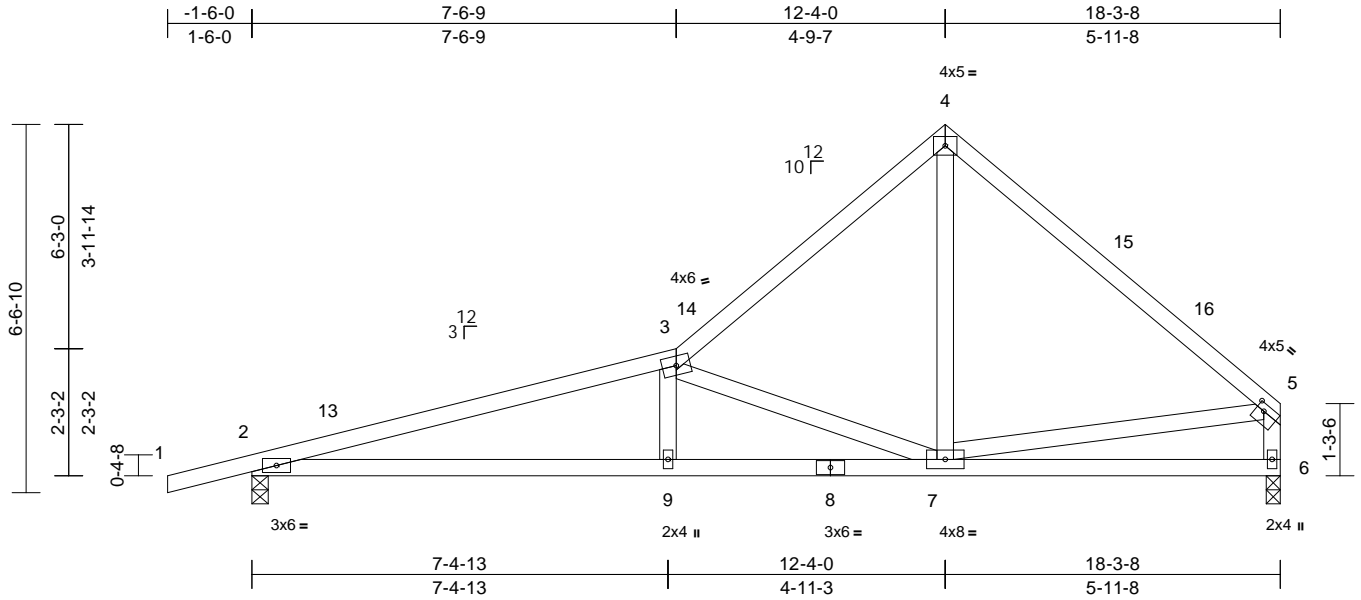

Scale = 1:41

Plate Offsets (X, Y): [5:0-1-12,0-1-8]

Loading	(psf)	Spacing	2-0-0	CSI	DEFL	in	(loc)	l/defl	L/d	PLATES	GRIP	
TCLL (roof)	20.0	Plate Grip DOL	1.25	TC	0.84	Vert(LL)	0.11	9-12	>999	240	MT20	244/190
TCDL	10.0	Lumber DOL	1.25	BC	0.75	Vert(CT)	-0.25	9-12	>880	180		
BCLL	0.0*	Rep Stress Incr	YES	WB	0.69	Horz(CT)	0.03	6	n/a	n/a		
BCDL	10.0	Code	FBC2023/TPI2014	Matrix-MS							Weight: 90 lb	FT = 20%

**LUMBER**

TOP CHORD 2x4 SP No.2  
BOT CHORD 2x4 SP No.2  
WEBS 2x4 SP No.3

**BRACING**

TOP CHORD Structural wood sheathing directly applied, except end verticals.  
BOT CHORD Rigid ceiling directly applied or 8-2-13 oc bracing.

**REACTIONS**

(size) 2=0-3-8, 6=0-3-0  
Max Horiz 2=154 (LC 9)  
Max Uplift 2=-226 (LC 12), 6=-153 (LC 12)  
Max Grav 2=820 (LC 1), 6=722 (LC 1)

**FORCES**

(lb) - Maximum Compression/Maximum Tension  
TOP CHORD 1-2=0/22, 2-3=-1819/487, 3-4=-773/257, 4-5=-769/257, 5-6=-661/263  
BOT CHORD 2-9=-484/1718, 7-9=-485/1707, 6-7=-99/151  
WEBS 3-9=0/252, 3-7=-1287/421, 4-7=-134/548, 5-7=-64/372

**NOTES**

- Unbalanced roof live loads have been considered for this design.
- Designed to ASCE 7-22 basic load combinations for allowable stress design unless otherwise noted.
- Wind: ASCE 7-22; Vult=130mph (3-second gust) Vasd=101mph; TC DL=4.2psf; BC DL=3.0psf; h=18ft; Cat. II; Exp B; Enclosed; MWFRS (envelope) exterior (2) zone and C-C Zone3 -1-6-0 to 1-6-0, Zone1 1-6-0 to 12-4-0, Zone2 12-4-0 to 16-6-15, Zone1 16-6-15 to 18-1-12 zone;C-C for members and forces & MWFRS for reactions shown; Lumber DOL=1.60 plate grip DOL=1.60
- Building Designer / Project engineer responsible for verifying applied roof live load shown covers rain loading requirements specific to the use of this truss component.
- This truss has been designed for a 10.0 psf bottom chord live load nonconcurrent with any other live loads.

- \* This truss has been designed for a live load of 20.0psf on the bottom chord in all areas where a rectangle 3-06-00 tall by 2-00-00 wide will fit between the bottom chord and any other members.
- Provide mechanical connection (by others) of truss to bearing plate capable of withstanding 153 lb uplift at joint 6 and 226 lb uplift at joint 2.

**LOAD CASE(S)** Standard

This item has been digitally signed and sealed by ORegan, Philip, PE on the date indicated here. Printed copies of this document are not considered signed and sealed and the signature must be verified on any electronic copies.

Philip J. O'Regan PE No.58126  
MiTek Inc. DBA MiTek USA FL Cert 63014  
16023 Swingley Ridge Rd. Chesterfield, MO 63017  
Date:

May 22,2026

**WARNING - Verify design parameters and READ NOTES ON THIS AND INCLUDED MITEK REFERENCE PAGE MII-7473 rev. 1/2/2023 BEFORE USE.**

Design valid for use only with MiTek® connectors. This design is based only upon parameters shown, and is for an individual building component, not a truss system. Before use, the building designer must verify the applicability of design parameters and properly incorporate this design into the overall building design. Bracing indicated is to prevent buckling of individual truss web and/or chord members only. Additional temporary and permanent bracing is always required for stability and to prevent collapse with possible personal injury and property damage. For general guidance regarding the fabrication, storage, delivery, erection and bracing of trusses and truss systems, see **ANSI/TPI1 Quality Criteria and DSB-22** available from Truss Plate Institute (www.tpinst.org) and **BCSI Building Component Safety Information** available from the Structural Building Component Association (www.sbcsccomponents.com)

**MiTek®**

16023 Swingley Ridge Rd.  
Chesterfield, MO 63017  
314.434.1200 / MiTek-US.com

Job 5449020	Truss T17G	Truss Type Roof Special Structural Gable	Qty 1	Ply 1	Job Reference (optional)	T41274312
----------------	---------------	---------------------------------------------	----------	----------	--------------------------	-----------

Builders FirstSource (Lake City,FL), Lake City, FL - 32055,

Run: 25.40 S Apr 17 2026 Print: 25.4.0 S Apr 17 2026 MiTek Industries, Inc. Wed May 20 15:14:31

Page: 1

ID:bvvt?qP8phk8g?XC8eocMbzEbou-RfC?PsB70Hq3NSgPqnL8w3uITxbGKWrCDoi7J4zJC?F

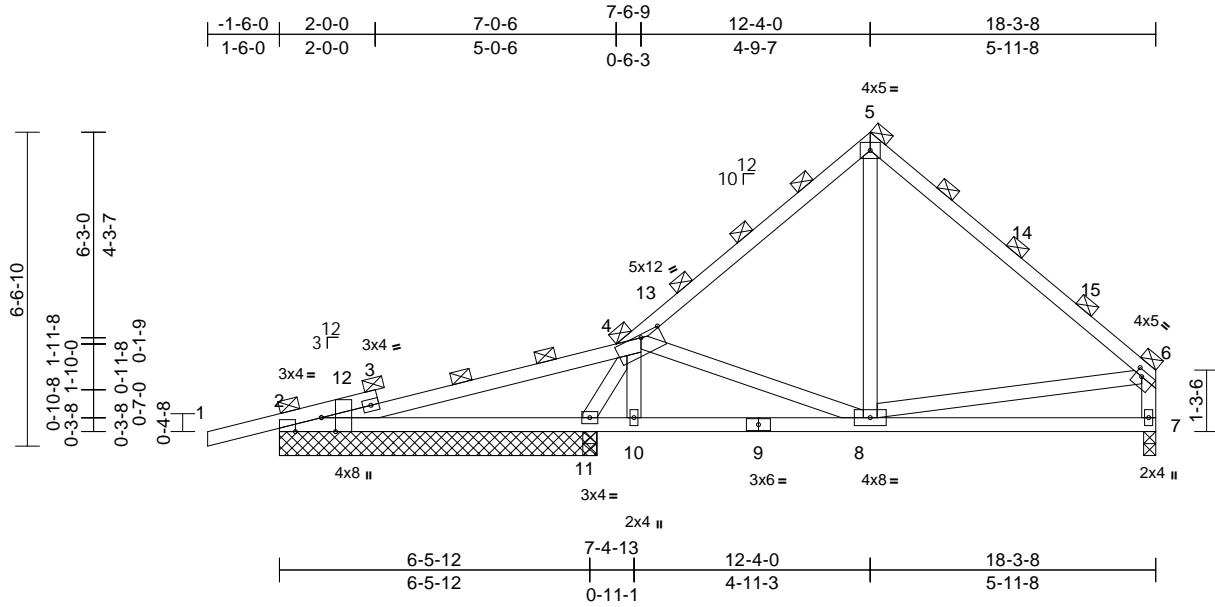

Scale = 1:48.1

Plate Offsets (X, Y): [2:0-3-8,Edge], [2:0-6-8,Edge], [4:0-5-0,0-0-12], [6:0-1-12,0-1-8]

Loading	(psf)	Spacing	2-0-0	CSI	DEFL	in	(loc)	l/defl	L/d	PLATES	GRIP	
TCLL (roof)	20.0	Plate Grip DOL	1.25	TC	0.64	Vert(LL)	0.04	2-11	>999	240	MT20	244/190
TCDL	10.0	Lumber DOL	1.25	BC	0.30	Vert(CT)	-0.08	2-11	>981	180		
BCLL	0.0*	Rep Stress Incr	YES	WB	0.16	Horz(CT)	-0.01	7	n/a	n/a		
BCDL	10.0	Code	FBC2023/TPI2014	Matrix-MS							Weight: 95 lb	FT = 20%

**LUMBER**  
 TOP CHORD 2x4 SP No.2  
 BOT CHORD 2x4 SP No.2  
 WEBS 2x4 SP No.3

**BRACING**  
 TOP CHORD 2-0-0 oc purlins, except end verticals.  
 BOT CHORD Rigid ceiling directly applied or 6-0-0 oc bracing, Except:  
 10-0-0 oc bracing: 7-8.

**REACTIONS** (size) 2=6-7-8, 7=0-3-0, 11=6-7-8  
 Max Horiz 2=153 (LC 9)  
 Max Uplift 2=-101 (LC 8), 7=-84 (LC 13),  
 11=-270 (LC 12)  
 Max Grav 2=203 (LC 25), 7=388 (LC 1),  
 11=952 (LC 1)

**FORCES** (lb) - Maximum Compression/Maximum Tension  
 TOP CHORD 1-2=0/22, 2-4=-338/728, 4-5=-340/141,  
 5-6=-351/141, 6-7=-333/173  
 BOT CHORD 2-11=-663/337, 10-11=-232/251,  
 8-10=-233/252, 7-8=-96/143  
 WEBS 4-10=-61/30, 4-8=-144/407, 5-8=-18/151,  
 6-8=-48/159, 4-11=-861/308

- NOTES**
- Unbalanced roof live loads have been considered for this design.
  - Designed to ASCE 7-22 basic load combinations for allowable stress design unless otherwise noted.
  - Wind: ASCE 7-22; Vult=130mph (3-second gust) Vasd=101mph; TC DL=4.2psf; BC DL=3.0psf; h=18ft; Cat. II; Exp B; Enclosed; MWFRS (envelope) exterior (2) zone and C-C Zone3 -1-6-0 to 1-6-0, Zone1 1-6-0 to 12-4-0, Zone2 12-4-0 to 16-6-15, Zone1 16-6-15 to 18-1-12 zone;C-C for members and forces & MWFRS for reactions shown; Lumber DOL=1.60 plate grip DOL=1.60
  - Building Designer / Project engineer responsible for verifying applied roof live load shown covers rain loading requirements specific to the use of this truss component.

- This truss has been designed for a 10.0 psf bottom chord live load nonconcurrent with any other live loads.
- \* This truss has been designed for a live load of 20.0psf on the bottom chord in all areas where a rectangle 3-06-00 tall by 2-00-00 wide will fit between the bottom chord and any other members.
- Provide mechanical connection (by others) of truss to bearing plate capable of withstanding 84 lb uplift at joint 7, 101 lb uplift at joint 2 and 270 lb uplift at joint 11.
- Graphical purlin representation does not depict the size or the orientation of the purlin along the top and/or bottom chord.

**LOAD CASE(S)** Standard

This item has been digitally signed and sealed by O'Regan, Philip, PE on the date indicated here. Printed copies of this document are not considered signed and sealed and the signature must be verified on any electronic copies.

Philip J. O'Regan PE No.58126  
 MiTek Inc. DBA MiTek USA FL Cert 6634  
 16023 Swingley Ridge Rd. Chesterfield, MO 63017  
 Date:

May 22,2026

**WARNING - Verify design parameters and READ NOTES ON THIS AND INCLUDED MITEK REFERENCE PAGE MII-7473 rev. 1/2/2023 BEFORE USE.**

Design valid for use only with MiTek® connectors. This design is based only upon parameters shown, and is for an individual building component, not a truss system. Before use, the building designer must verify the applicability of design parameters and properly incorporate this design into the overall building design. Bracing indicated is to prevent buckling of individual truss web and/or chord members only. Additional temporary and permanent bracing is always required for stability and to prevent collapse with possible personal injury and property damage. For general guidance regarding the fabrication, storage, delivery, erection and bracing of trusses and truss systems, see **ANSI/TPI1 Quality Criteria and DSB-22** available from Truss Plate Institute (www.tpinst.org) and **BCSI Building Component Safety Information** available from the Structural Building Component Association (www.sbcsccomponents.com)

**MiTek®**

16023 Swingley Ridge Rd.  
 Chesterfield, MO 63017  
 314.434.1200 / MiTek-US.com

Job 5449020	Truss T18	Truss Type Common	Qty 5	Ply 1	Job Reference (optional) T41274313
----------------	--------------	----------------------	----------	----------	---------------------------------------

Builders FirstSource (Lake City,FL), Lake City, FL - 32055,

Run: 25.40 S Apr 17 2026 Print: 25.4.0 S Apr 17 2026 MiTek Industries, Inc. Wed May 20 15:14:32

Page: 1

ID:ZbTV5vuTDx4BwxtY51DoJ6zEcjJ-RfC?PsB70Hq3NSgPqnL8w3uITXbGKwRCDoi7J4zJC7f

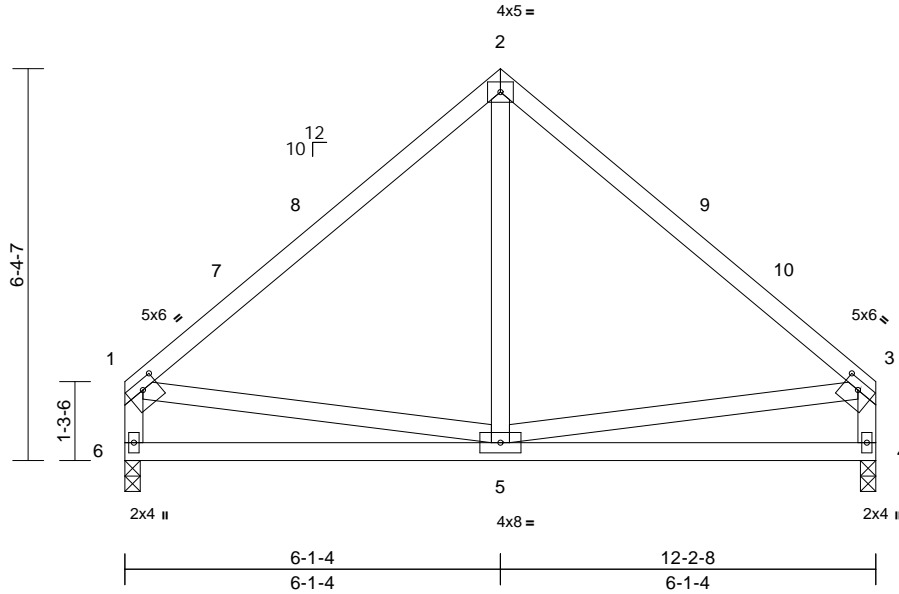

Scale = 1:37.5

Plate Offsets (X, Y): [1:0-3-0,0-1-12], [3:0-3-0,0-1-12]

Loading	(psf)	Spacing	2-0-0	CSI	DEFL	in	(loc)	l/defl	L/d	PLATES	GRIP	
TCLL (roof)	20.0	Plate Grip DOL	1.25	TC	0.46	Vert(LL)	-0.03	5-6	>999	240	MT20	244/190
TCDL	10.0	Lumber DOL	1.25	BC	0.31	Vert(CT)	-0.05	5-6	>999	180		
BCLL	0.0*	Rep Stress Incr	YES	WB	0.09	Horz(CT)	0.00	4	n/a	n/a		
BCDL	10.0	Code	FBC2023/TPI2014	Matrix-MS							Weight: 71 lb	FT = 20%

**LUMBER**

TOP CHORD 2x4 SP No.2  
 BOT CHORD 2x4 SP No.2  
 WEBS 2x4 SP No.3

**BRACING**

TOP CHORD Structural wood sheathing directly applied, except end verticals.  
 BOT CHORD Rigid ceiling directly applied or 10-0-0 oc bracing.

**REACTIONS**

(size) 4=0-3-0, 6=0-3-0  
 Max Horiz 6=123 (LC 9)  
 Max Uplift 4=-95 (LC 13), 6=-95 (LC 12)  
 Max Grav 4=477 (LC 1), 6=477 (LC 1)

**FORCES**

(lb) - Maximum Compression/Maximum Tension  
 TOP CHORD 1-2=-460/168, 2-3=-460/168, 1-6=-424/190, 3-4=-424/190  
 BOT CHORD 5-6=-173/234, 4-5=-98/143  
 WEBS 2-5=0/226, 1-5=-63/204, 3-5=-65/206

**NOTES**

- 1) Unbalanced roof live loads have been considered for this design.
- 2) Designed to ASCE 7-22 basic load combinations for allowable stress design unless otherwise noted.
- 3) Wind: ASCE 7-22; Vult=130mph (3-second gust) Vasd=101mph; TCDL=4.2psf; BCDL=3.0psf; h=18ft; Cat. II; Exp B; Enclosed; MWFRS (envelope) exterior (2) zone and C-C Zone3 0-2-4 to 3-2-4, Zone1 3-2-4 to 6-1-12, Zone2 6-1-12 to 10-4-11, Zone1 10-4-11 to 12-1-4 zone;C-C for members and forces & MWFRS for reactions shown; Lumber DOL=1.60 plate grip DOL=1.60
- 4) Building Designer / Project engineer responsible for verifying applied roof live load shown covers rain loading requirements specific to the use of this truss component.
- 5) This truss has been designed for a 10.0 psf bottom chord live load nonconcurrent with any other live loads.

- 6) \* This truss has been designed for a live load of 20.0psf on the bottom chord in all areas where a rectangle 3-06-00 tall by 2-00-00 wide will fit between the bottom chord and any other members.
- 7) Provide mechanical connection (by others) of truss to bearing plate at joint(s) 4.
- 8) Provide mechanical connection (by others) of truss to bearing plate capable of withstanding 95 lb uplift at joint 6 and 95 lb uplift at joint 4.

**LOAD CASE(S)** Standard

This item has been digitally signed and sealed by ORegan, Philip, PE on the date indicated here. Printed copies of this document are not considered signed and sealed and the signature must be verified on any electronic copies.

Philip J. O'Regan PE No.58126  
 MiTek Inc. DBA MiTek USA FL Cert 6634  
 16023 Swingley Ridge Rd. Chesterfield, MO 63017  
 Date:

May 22,2026

**WARNING - Verify design parameters and READ NOTES ON THIS AND INCLUDED MITEK REFERENCE PAGE MII-7473 rev. 1/2/2023 BEFORE USE.**

Design valid for use only with MiTek® connectors. This design is based only upon parameters shown, and is for an individual building component, not a truss system. Before use, the building designer must verify the applicability of design parameters and properly incorporate this design into the overall building design. Bracing indicated is to prevent buckling of individual truss web and/or chord members only. Additional temporary and permanent bracing is always required for stability and to prevent collapse with possible personal injury and property damage. For general guidance regarding the fabrication, storage, delivery, erection and bracing of trusses and truss systems, see **ANSI/TPI1 Quality Criteria and DSB-22** available from Truss Plate Institute (www.tpinst.org) and **BCSI Building Component Safety Information** available from the Structural Building Component Association (www.sbcsccomponents.com)

**MiTek®**

16023 Swingley Ridge Rd.  
 Chesterfield, MO 63017  
 314.434.1200 / MiTek-US.com

Job 5449020	Truss T18G	Truss Type Common Supported Gable	Qty 1	Ply 1	Job Reference (optional) T41274314
----------------	---------------	--------------------------------------	----------	----------	---------------------------------------

Builders FirstSource (Lake City,FL), Lake City, FL - 32055,

Run: 25.40 S Apr 17 2026 Print: 25.4.0 S Apr 17 2026 MiTek Industries, Inc. Wed May 20 15:14:32

Page: 1

ID:DRFuleSJO3tgr?ONoi2bApzEcib-RfC?PsB70Hq3NSgPqnLw3uITXbGKWrCdoi7J4zJC?f

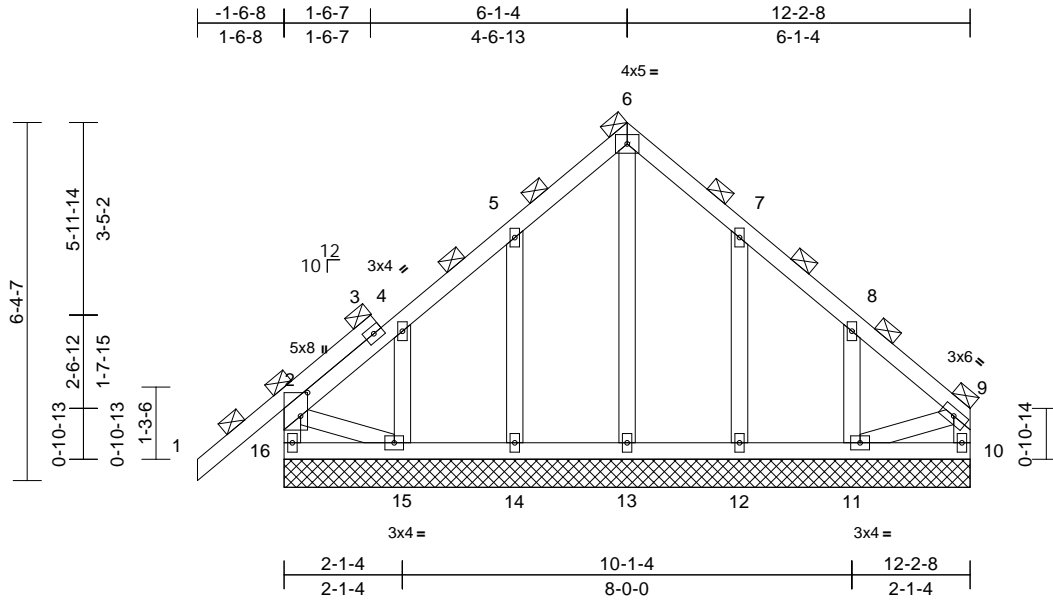

Scale = 1:41  
Plate Offsets (X, Y): [2:0-5:0,0-1-8]

Loading	(psf)	Spacing	2-0-0	CSI	DEFL	in	(loc)	l/defl	L/d	PLATES	GRIP	
TCLL (roof)	20.0	Plate Grip DOL	1.25	TC	0.22	Vert(LL)	n/a	-	n/a	999	MT20	244/190
TCDL	10.0	Lumber DOL	1.25	BC	0.03	Vert(CT)	n/a	-	n/a	999		
BCLL	0.0*	Rep Stress Incr	YES	WB	0.06	Horz(CT)	0.00	11	n/a	n/a		
BCDL	10.0	Code	FBC2023/TPI2014	Matrix-MS							Weight: 81 lb	FT = 20%

**LUMBER**  
TOP CHORD 2x4 SP No.2  
BOT CHORD 2x4 SP No.2  
WEBS 2x4 SP No.3  
OTHERS 2x4 SP No.3

**BRACING**  
TOP CHORD 2-0-0 oc purlins, except end verticals.  
BOT CHORD Rigid ceiling directly applied or 10-0-0 oc bracing. Except:  
6-0-0 oc bracing: 15-16.

**REACTIONS** (size)  
10=12-2-8, 11=12-2-8, 12=12-2-8,  
13=12-2-8, 14=12-2-8, 15=12-2-8,  
16=12-2-8  
Max Horiz 16=156 (LC 9)  
Max Uplift 10=-19 (LC 9), 11=-147 (LC 13),  
12=-104 (LC 13), 14=-110 (LC 12),  
15=-127 (LC 12), 16=-49 (LC 8)  
Max Grav 10=108 (LC 22), 11=201 (LC 20),  
12=181 (LC 20), 13=142 (LC 22),  
14=188 (LC 19), 15=160 (LC 19),  
16=229 (LC 1)

**FORCES** (lb) - Maximum Compression/Maximum Tension  
TOP CHORD 2-16=-213/85, 1-2=0/58, 2-4=-110/77,  
4-5=-87/62, 5-6=-85/139, 9-10=-90/24,  
6-7=-84/138, 7-8=-69/36, 8-9=-99/65  
BOT CHORD 15-16=-133/126, 14-15=-49/107,  
13-14=-49/107, 12-13=-49/107,  
11-12=-49/107, 10-11=-10/16  
WEBS 6-13=-102/15, 5-14=-150/161, 4-15=-111/116,  
7-12=-142/152, 8-11=-142/163, 2-15=-79/152,  
9-11=-63/124

**NOTES**  
1) Unbalanced roof live loads have been considered for this design.  
2) Designed to ASCE 7-22 basic load combinations for allowable stress design unless otherwise noted.

- Wind: ASCE 7-22; Vult=130mph (3-second gust) Vasd=101mph; TC DL=4.2psf; BCDL=3.0psf; h=18ft; Cat. II; Exp B; Enclosed; MWFRS (envelope) exterior (2) zone and C-C Zone3 zone; end vertical left exposed; C-C for members and forces & MWFRS for reactions shown; Lumber DOL=1.60 plate grip DOL=1.60
- Truss designed for wind loads in the plane of the truss only. For studs exposed to wind (normal to the face), see Standard Industry Gable End Details as applicable, or consult qualified building designer as per ANSI/TPI 1.
- Building Designer / Project engineer responsible for verifying applied roof live load shown covers rain loading requirements specific to the use of this truss component.
- All plates are 2x4 (||) MT20 unless otherwise indicated.
- Gable requires continuous bottom chord bearing.
- Truss to be fully sheathed from one face or securely braced against lateral movement (i.e. diagonal web).
- Gable studs spaced at 2-0-0 oc.
- This truss has been designed for a 10.0 psf bottom chord live load nonconcurrent with any other live loads.
- \* This truss has been designed for a live load of 20.0psf on the bottom chord in all areas where a rectangle 3-06-00 tall by 2-00-00 wide will fit between the bottom chord and any other members.
- Provide mechanical connection (by others) of truss to bearing plate capable of withstanding 49 lb uplift at joint 16, 19 lb uplift at joint 10, 110 lb uplift at joint 14, 127 lb uplift at joint 15, 104 lb uplift at joint 12 and 147 lb uplift at joint 11.
- Graphical purlin representation does not depict the size or the orientation of the purlin along the top and/or bottom chord.

**LOAD CASE(S)** Standard

This item has been digitally signed and sealed by O'Regan, Philip, PE on the date indicated here. Printed copies of this document are not considered signed and sealed and the signature must be verified on any electronic copies.

Philip J. O'Regan PE No.58126  
MiTek Inc. DBA MiTek USA FL Cert 6634  
16023 Swingley Ridge Rd. Chesterfield, MO 63017  
Date:

May 22, 2026

<p><b>WARNING - Verify design parameters and READ NOTES ON THIS AND INCLUDED MITEK REFERENCE PAGE MII-7473 rev. 1/2/2023 BEFORE USE.</b></p> <p>Design valid for use only with MiTek® connectors. This design is based only upon parameters shown, and is for an individual building component, not a truss system. Before use, the building designer must verify the applicability of the design parameters and properly incorporate this design into the overall building design. Bracing indicated is to prevent buckling of individual truss web and/or chord members only. Additional temporary and permanent bracing is always required for stability and to prevent collapse with possible personal injury and property damage. For general guidance regarding the fabrication, storage, delivery, erection and bracing of trusses and truss systems, see <b>ANSI/TPI1 Quality Criteria and DSB-22</b> available from Truss Plate Institute (www.tpinst.org) and <b>BCSI Building Component Safety Information</b> available from the Structural Building Component Association (www.sbcsccomponents.com)</p>	 <p>16023 Swingley Ridge Rd.  Chesterfield, MO 63017  314.434.1200 / MiTek-US.com</p>
----------------------------------------------------------------------------------------------------------------------------------------------------------------------------------------------------------------------------------------------------------------------------------------------------------------------------------------------------------------------------------------------------------------------------------------------------------------------------------------------------------------------------------------------------------------------------------------------------------------------------------------------------------------------------------------------------------------------------------------------------------------------------------------------------------------------------------------------------------------------------------------------------------------------------------------------------------------------------------------------------------------------------------------------------------------------------------------------------------------------	------------------------------------------------------------------------------------------------------------------------------------------------------------------------------------

Job 5449020	Truss T19	Truss Type Common Girder	Qty 1	Ply 2	Job Reference (optional) T41274315
----------------	--------------	-----------------------------	----------	----------	---------------------------------------

Builders FirstSource (Lake City,FL), Lake City, FL - 32055,

Run: 25.40 S Apr 17 2026 Print: 25.4.0 S Apr 17 2026 MiTek Industries, Inc. Wed May 20 15:14:32  
ID:XjrbQvYZenLOV4JsmToCQezEbhw-RfC?PsB70Hq3NSgPqnL8w3ulTXbGKWrCDoi7J4zJC7f

Page: 1

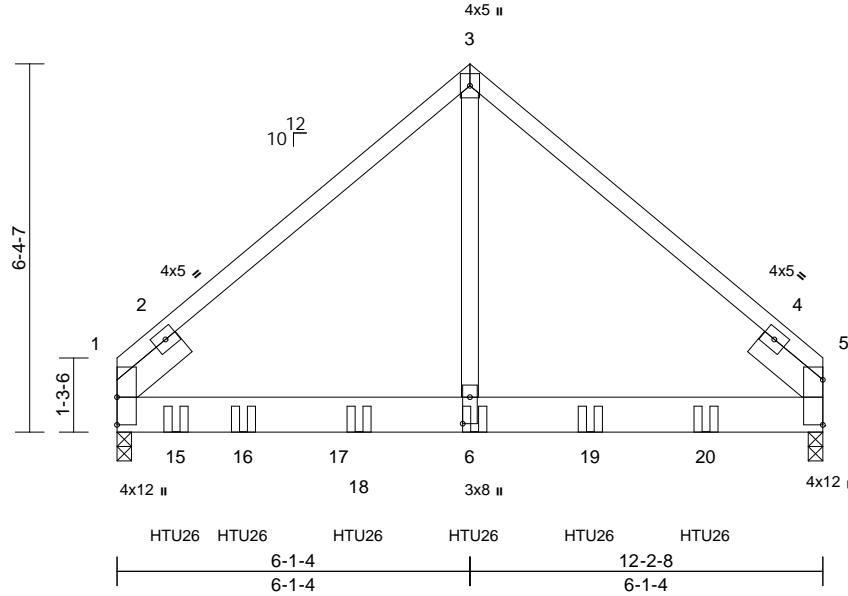

Scale = 1:39.9

Plate Offsets (X, Y): [5:Edge,0-0-0], [5:0-0-0,0-0-0], [6:0-5-8,0-1-8]

Loading	(psf)	Spacing	2-0-0	CSI	DEFL	in	(loc)	l/defl	L/d	PLATES	GRIP	
TCLL (roof)	20.0	Plate Grip DOL	1.25	TC	0.36	Vert(LL)	-0.04	6-9	>999	240	MT20	244/190
TCDL	10.0	Lumber DOL	1.25	BC	0.23	Vert(CT)	-0.07	6-9	>999	180		
BCLL	0.0*	Rep Stress Incr	NO	WB	0.61	Horz(CT)	0.01	5	n/a	n/a		
BCDL	10.0	Code	FBC2023/TPI2014	Matrix-MS							Weight: 154 lb	FT = 20%

LUMBER	
TOP CHORD	2x4 SP No.2
BOT CHORD	2x8 SP 2400F 2.0E
WEBS	2x4 SP No.3
SLIDER	Left 2x6 SP No.2 -- 1-6-0, Right 2x6 SP No.2 -- 1-6-0

BRACING	
TOP CHORD	Structural wood sheathing directly applied.
BOT CHORD	Rigid ceiling directly applied or 10-0-0 oc bracing.

REACTIONS	(size)	1=0-3-0, 5=0-3-0
Max Horiz	1=126 (LC 5)	
Max Uplift	1=-661 (LC 8), 5=-532 (LC 9)	
Max Grav	1=3734 (LC 2), 5=3000 (LC 2)	

FORCES	(lb) - Maximum Compression/Maximum Tension
TOP CHORD	1-3=-2792/563, 3-5=-2797/564
BOT CHORD	1-6=-359/2073, 5-6=-359/2073
WEBS	3-6=-567/3225

#### NOTES

- 2-ply truss to be connected together with 10d (0.131"x3") nails as follows:  
Top chords connected as follows: 2x4 - 1 row at 0-9-0 oc.  
Bottom chords connected as follows: 2x8 - 2 rows staggered at 0-9-0 oc.  
Web connected as follows: 2x4 - 1 row at 0-9-0 oc.
- All loads are considered equally applied to all plies, except if noted as front (F) or back (B) face in the LOAD CASE(S) section. Ply to ply connections have been provided to distribute only loads noted as (F) or (B), unless otherwise indicated.
- Unbalanced roof live loads have been considered for this design.
- Designed to ASCE 7-22 basic load combinations for allowable stress design unless otherwise noted.

- Wind: ASCE 7-22; Vult=130mph (3-second gust)  
Vasd=101mph; TCDL=4.2psf; BCDL=3.0psf; h=18ft; Cat. II; Exp B; Enclosed; MWFRS (envelope) exterior (2) zone; Lumber DOL=1.60 plate grip DOL=1.60
- Building Designer / Project engineer responsible for verifying applied roof live load shown covers rain loading requirements specific to the use of this truss component.
- This truss has been designed for a 10.0 psf bottom chord live load nonconcurrent with any other live loads.
- \* This truss has been designed for a live load of 20.0psf on the bottom chord in all areas where a rectangle 3-06-00 tall by 2-00-00 wide will fit between the bottom chord and any other members, with BCDL = 10.0psf.
- Provide mechanical connection (by others) of truss to bearing plate at joint(s) 5.
- Provide mechanical connection (by others) of truss to bearing plate capable of withstanding 661 lb uplift at joint 1 and 532 lb uplift at joint 5.
- Use Simpson Strong-Tie HTU26 (20-16d Girder, 11-10dx1 1/2 Truss, Single Ply Girder) or equivalent spaced at 2-0-0 oc max. starting at 1-0-12 from the left end to 10-2-12 to connect truss(es) to front face of bottom chord.
- Fill all nail holes where hanger is in contact with lumber.

#### LOAD CASE(S) Standard

- Dead + Roof Live (balanced): Lumber Increase=1.25, Plate Increase=1.25  
Uniform Loads (lb/ft)  
Vert: 1-3=-60, 3-5=-60, 7-11=-20  
Concentrated Loads (lb)  
Vert: 6=-862 (F), 15=-862 (F), 16=-862 (F), 18=-862 (F), 19=-862 (F), 20=-862 (F)

This item has been digitally signed and sealed by O'Regan, Philip, PE on the date indicated here. Printed copies of this document are not considered signed and sealed and the signature must be verified on any electronic copies.

Philip J. O'Regan PE No.58126  
MiTek Inc. DBA MiTek USA FL Cert 6634  
16023 Swingley Ridge Rd. Chesterfield, MO 63017  
Date:

May 22, 2026

#### WARNING - Verify design parameters and READ NOTES ON THIS AND INCLUDED MITEK REFERENCE PAGE MII-7473 rev. 1/2/2023 BEFORE USE.

Design valid for use only with MiTek® connectors. This design is based only upon parameters shown, and is for an individual building component, not a truss system. Before use, the building designer must verify the applicability of design parameters and properly incorporate this design into the overall building design. Bracing indicated is to prevent buckling of individual truss web and/or chord members only. Additional temporary and permanent bracing is always required for stability and to prevent collapse with possible personal injury and property damage. For general guidance regarding the fabrication, storage, delivery, erection and bracing of trusses and truss systems, see **ANSI/TPI1 Quality Criteria and DSB-22** available from Truss Plate Institute (www.tpinst.org) and **BCSI Building Component Safety Information** available from the Structural Building Component Association (www.sbcsccomponents.com)

**MiTek®**

16023 Swingley Ridge Rd.  
Chesterfield, MO 63017  
314.434.1200 / MiTek-US.com

Job 5449020	Truss T20	Truss Type Monopitch	Qty 10	Ply 1	Job Reference (optional) T41274316
----------------	--------------	-------------------------	-----------	----------	---------------------------------------

Builders FirstSource (Lake City,FL), Lake City, FL - 32055,

Run: 25.40 S Apr 17 2026 Print: 25.4.0 S Apr 17 2026 MiTek Industries, Inc. Wed May 20 15:14:32  
ID:Zjy4W5hoDixcOJ4HczPp7XzEcja-RfC?PsB70Hq3NSgPqnL8w3ulTXbGKWrCDoi7J4zJC?f

Page: 1

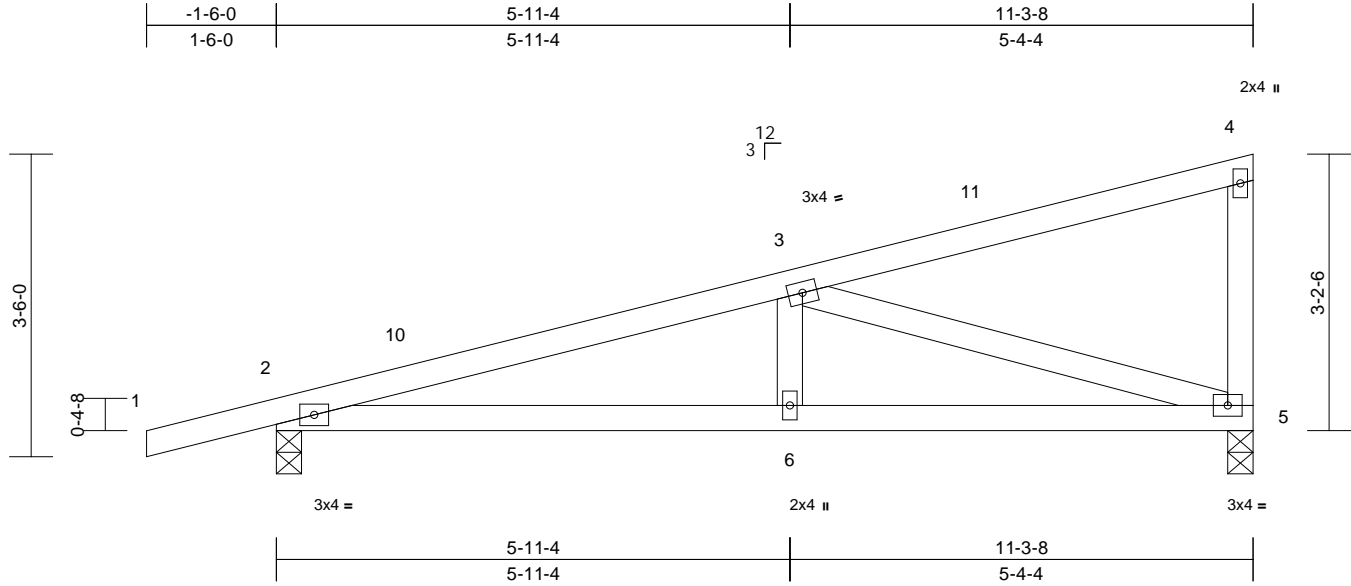

Loading	(psf)	Spacing	2-0-0	CSI	DEFL	in	(loc)	l/defl	L/d	PLATES	GRIP	
TCLL (roof)	20.0	Plate Grip DOL	1.25	TC	0.32	Vert(LL)	0.06	6-9	>999	240	MT20	244/190
TCDL	10.0	Lumber DOL	1.25	BC	0.37	Vert(CT)	-0.08	6-9	>999	180		
BCLL	0.0*	Rep Stress Incr	YES	WB	0.53	Horz(CT)	0.02	5	n/a	n/a		
BCDL	10.0	Code	FBC2023/TPI2014	Matrix-MS							Weight: 50 lb	FT = 20%

**LUMBER**  
TOP CHORD 2x4 SP No.2  
BOT CHORD 2x4 SP No.2  
WEBS 2x4 SP No.3

**BRACING**  
TOP CHORD Structural wood sheathing directly applied, except end verticals.  
BOT CHORD Rigid ceiling directly applied or 7-0-12 oc bracing.

**REACTIONS** (size) 2=0-3-8, 5=0-3-8  
Max Horiz 2=127 (LC 8)  
Max Uplift 2=-292 (LC 8), 5=-247 (LC 8)  
Max Grav 2=542 (LC 1), 5=440 (LC 1)

**FORCES** (lb) - Maximum Compression/Maximum Tension  
TOP CHORD 1-2=0/22, 2-3=-961/585, 3-4=-69/9, 4-5=-128/138  
BOT CHORD 2-6=-670/910, 5-6=-670/910  
WEBS 3-5=-924/673, 3-6=-110/243

- \* This truss has been designed for a live load of 20.0psf on the bottom chord in all areas where a rectangle 3-06-00 tall by 2-00-00 wide will fit between the bottom chord and any other members.
  - Provide mechanical connection (by others) of truss to bearing plate capable of withstanding 292 lb uplift at joint 2 and 247 lb uplift at joint 5.
- LOAD CASE(S)** Standard

- NOTES**
- Unbalanced roof live loads have been considered for this design.
  - Designed to ASCE 7-22 basic load combinations for allowable stress design unless otherwise noted.
  - Wind: ASCE 7-22; Vult=130mph (3-second gust) Vasd=101mph; TCDL=4.2psf; BCDL=3.0psf; h=18ft; Cat. II; Exp B; Enclosed; MWFRS (envelope) exterior (2) zone and C-C Zone3 -1-6-0 to 1-6-0, Zone1 1-6-0 to 11-1-12 zone; porch left and right exposed; C-C for members and forces & MWFRS for reactions shown; Lumber DOL=1.60 plate grip DOL=1.60
  - Building Designer / Project engineer responsible for verifying applied roof live load shown covers rain loading requirements specific to the use of this truss component.
  - This truss has been designed for a 10.0 psf bottom chord live load nonconcurrent with any other live loads.

This item has been digitally signed and sealed by ORegan, Philip, PE on the date indicated here. Printed copies of this document are not considered signed and sealed and the signature must be verified on any electronic copies.

Philip J. O'Regan PE No.58126  
MiTek Inc. DBA MiTek USA FL Cert 6634  
16023 Swingley Ridge Rd. Chesterfield, MO 63017  
Date:

May 22, 2026

<p><b>WARNING - Verify design parameters and READ NOTES ON THIS AND INCLUDED MITEK REFERENCE PAGE MII-7473 rev. 1/2/2023 BEFORE USE.</b></p> <p>Design valid for use only with MiTek® connectors. This design is based only upon parameters shown, and is for an individual building component, not a truss system. Before use, the building designer must verify the applicability of design parameters and properly incorporate this design into the overall building design. Bracing indicated is to prevent buckling of individual truss web and/or chord members only. Additional temporary and permanent bracing is always required for stability and to prevent collapse with possible personal injury and property damage. For general guidance regarding the fabrication, storage, delivery, erection and bracing of trusses and truss systems, see <b>ANSI/TPI1 Quality Criteria and DSB-22</b> available from Truss Plate Institute (www.tpinst.org) and <b>BCSI Building Component Safety Information</b> available from the Structural Building Component Association (www.sbcsccomponents.com)</p>	 <p>16023 Swingley Ridge Rd.  Chesterfield, MO 63017  314.434.1200 / MiTek-US.com</p>
------------------------------------------------------------------------------------------------------------------------------------------------------------------------------------------------------------------------------------------------------------------------------------------------------------------------------------------------------------------------------------------------------------------------------------------------------------------------------------------------------------------------------------------------------------------------------------------------------------------------------------------------------------------------------------------------------------------------------------------------------------------------------------------------------------------------------------------------------------------------------------------------------------------------------------------------------------------------------------------------------------------------------------------------------------------------------------------------------------------	------------------------------------------------------------------------------------------------------------------------------------------------------------------------------------

Job 5449020	Truss T21	Truss Type Piggyback Base	Qty 4	Ply 1	Job Reference (optional) T41274317
----------------	--------------	------------------------------	----------	----------	---------------------------------------

Builders FirstSource (Lake City,FL), Lake City, FL - 32055,

Run: 25.40 S Apr 17 2026 Print: 25.4.0 S Apr 17 2026 MiTek Industries, Inc. Wed May 20 15:14:32

Page: 1

ID:jcWdmv9R9fiM1\_ZwsCOSWDzEbu1-RfC?PsB70Hq3NSgPqnL8w3uITxBGKWrCDoi7J4zJC7f

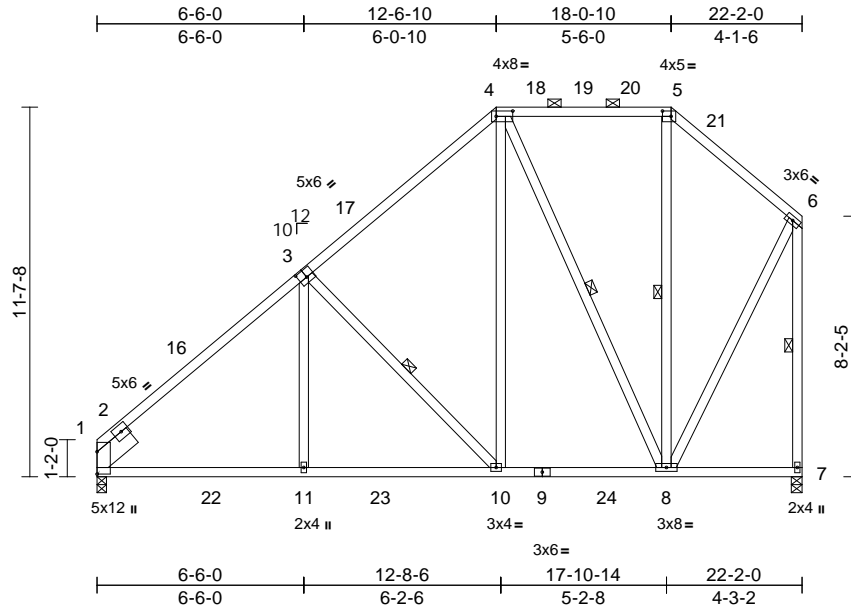

Scale = 1:72.5

Plate Offsets (X, Y): [3:0-3-0,0-3-0], [4:0-6-4,0-2-0], [5:0-3-4,0-2-0]

Loading	(psf)	Spacing	2-0-0	CSI	DEFL	in	(loc)	l/defl	L/d	PLATES	GRIP	
TCLL (roof)	20.0	Plate Grip DOL	1.25	TC	0.59	Vert(LL)	-0.07	10-11	>999	240	MT20	244/190
TCDL	10.0	Lumber DOL	1.25	BC	0.66	Vert(CT)	-0.14	10-11	>999	180		
BCLL	0.0*	Rep Stress Incr	YES	WB	0.42	Horz(CT)	-0.03	1	n/a	n/a		
BCDL	10.0	Code	FBC2023/TPI2014	Matrix-MS							Weight: 176 lb	FT = 20%

- LUMBER**
- TOP CHORD 2x4 SP No.2
  - BOT CHORD 2x4 SP No.2
  - WEBS 2x4 SP No.3 \*Except\* 8-4:2x4 SP No.2
  - SLIDER Left 2x8 SP 2400F 2.0E -- 1-6-0
- BRACING**
- TOP CHORD Structural wood sheathing directly applied, except end verticals, and 2-0-0 oc purlins: 4-5.
  - BOT CHORD Rigid ceiling directly applied or 9-3-4 oc bracing.
  - WEBS 1 Row at midpt 3-10, 4-8, 5-8, 6-7
- REACTIONS** (size) 1=0-3-8, 7=0-4-0
- Max Horiz 1=332 (LC 12)
  - Max Uplift 1=-170 (LC 12), 7=-251 (LC 12)
  - Max Grav 1=1024 (LC 19), 7=991 (LC 2)
- FORCES** (lb) - Maximum Compression/Maximum Tension
- TOP CHORD 1-4=-1129/217, 4-5=-308/162, 5-6=-458/155, 6-7=-935/261
  - BOT CHORD 1-11=-426/895, 10-11=-374/895, 8-10=-167/533, 7-8=-3/5
  - WEBS 3-11=0/306, 3-10=-524/297, 4-10=-167/624, 4-8=-533/213, 5-8=-120/110, 6-8=-162/662

- 4) Building Designer / Project engineer responsible for verifying applied roof live load shown covers rain loading requirements specific to the use of this truss component.
- 5) Provide adequate drainage to prevent water ponding.
- 6) This truss has been designed for a 10.0 psf bottom chord live load nonconcurrent with any other live loads.
- 7) \* This truss has been designed for a live load of 20.0psf on the bottom chord in all areas where a rectangle 3-06-00 tall by 2-00-00 wide will fit between the bottom chord and any other members, with BCDL = 10.0psf.
- 8) Provide mechanical connection (by others) of truss to bearing plate capable of withstanding 251 lb uplift at joint 7 and 170 lb uplift at joint 1.
- 9) Graphical purlin representation does not depict the size or the orientation of the purlin along the top and/or bottom chord.

**LOAD CASE(S)** Standard

- NOTES**
- 1) Unbalanced roof live loads have been considered for this design.
  - 2) Designed to ASCE 7-22 basic load combinations for allowable stress design unless otherwise noted.
  - 3) Wind: ASCE 7-22; Vult=130mph (3-second gust) Vasd=101mph; TC DL=4.2psf; BCDL=3.0psf; h=18ft; Cat. II; Exp B; Enclosed; MWFRS (envelope) exterior (2) zone and C-C Zone3 0-0-0 to 3-0-0, Zone1 3-0-0 to 12-6-10, Zone2 12-6-10 to 16-9-8, Zone1 16-9-8 to 18-0-10, Zone3 18-0-10 to 22-0-4 zone;C-C for members and forces & MWFRS for reactions shown; Lumber DOL=1.60 plate grip DOL=1.60

This item has been digitally signed and sealed by O'Regan, Philip, PE on the date indicated here. Printed copies of this document are not considered signed and sealed and the signature must be verified on any electronic copies.

Philip J. O'Regan PE No.58126  
MiTek Inc. DBA MiTek USA FL Cert 6634  
16023 Swingley Ridge Rd. Chesterfield, MO 63017  
Date:

May 22,2026

<p><b>WARNING - Verify design parameters and READ NOTES ON THIS AND INCLUDED MITEK REFERENCE PAGE MII-7473 rev. 1/2/2023 BEFORE USE.</b></p> <p>Design valid for use only with MiTek® connectors. This design is based only upon parameters shown, and is for an individual building component, not a truss system. Before use, the building designer must verify the applicability of design parameters and properly incorporate this design into the overall building design. Bracing indicated is to prevent buckling of individual truss web and/or chord members only. Additional temporary and permanent bracing is always required for stability and to prevent collapse with possible personal injury and property damage. For general guidance regarding the fabrication, storage, delivery, erection and bracing of trusses and truss systems, see <b>ANSI/TPI1 Quality Criteria and DSB-22</b> available from Truss Plate Institute (www.tpinst.org) and <b>BCSI Building Component Safety Information</b> available from the Structural Building Component Association (www.sbcsccomponents.com)</p>	 <p>16023 Swingley Ridge Rd. Chesterfield, MO 63017 314.434.1200 / MiTek-US.com</p>
------------------------------------------------------------------------------------------------------------------------------------------------------------------------------------------------------------------------------------------------------------------------------------------------------------------------------------------------------------------------------------------------------------------------------------------------------------------------------------------------------------------------------------------------------------------------------------------------------------------------------------------------------------------------------------------------------------------------------------------------------------------------------------------------------------------------------------------------------------------------------------------------------------------------------------------------------------------------------------------------------------------------------------------------------------------------------------------------------------------	----------------------------------------------------------------------------------------------------------------------------------------------------------------------------------

Job 5449020	Truss T21G	Truss Type Piggyback Base Girder	Qty 1	Ply 1	Job Reference (optional) T41274318
----------------	---------------	-------------------------------------	----------	----------	---------------------------------------

Builders FirstSource (Lake City,FL), Lake City, FL - 32055,

Run: 25.40 S Apr 17 2026 Print: 25.4.0 S Apr 17 2026 MiTek Industries, Inc. Wed May 20 15:14:32  
ID:LzWjGhA8eEgILpzEbjh-RfC?PsB70Hq3NSgPqnL8w3UuTxbGKwRCDoi7J4zJc7f

Page: 1

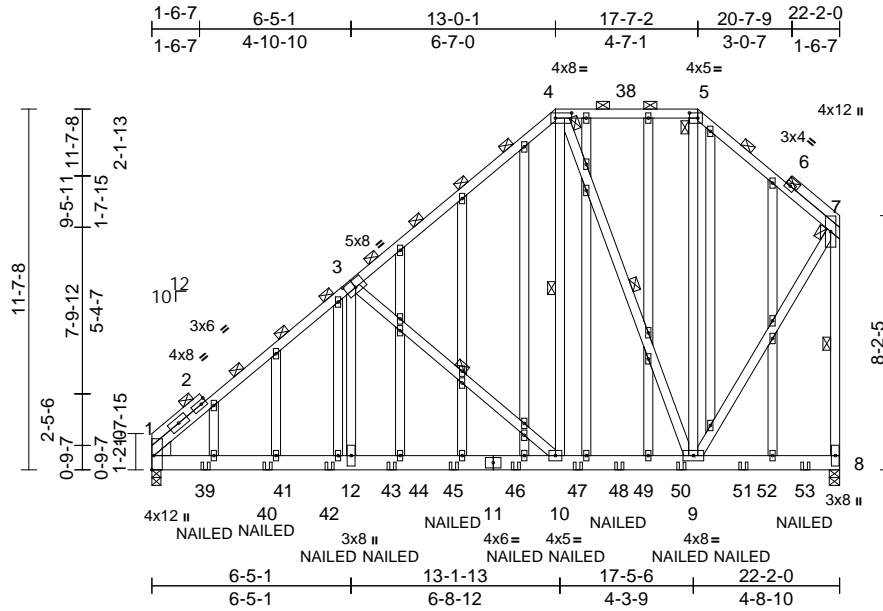

Scale = 1:74.2

Plate Offsets (X, Y): [1:Edge,0-0-12], [3:0-4-0,0-3-0], [4:0-6-4,0-2-0], [5:0-3-4,0-2-0]

Loading	(psf)	Spacing	2-0-0	CSI	DEFL	in	(loc)	l/defl	L/d	PLATES	GRIP	
TCLL (roof)	20.0	Plate Grip DOL	1.25	TC	0.81	Vert(LL)	0.10	1-12	>999	240	MT20	244/190
TCDL	10.0	Lumber DOL	1.25	BC	0.97	Vert(CT)	-0.18	1-12	>999	180		
BCLL	0.0*	Rep Stress Incr	NO	WB	0.69	Horz(CT)	0.02	8	n/a	n/a		
BCDL	10.0	Code	FBC2023/TPI2014	Matrix-MS							Weight: 307 lb	FT = 20%

**LUMBER**  
TOP CHORD 2x4 SP No.2 \*Except\* 1-3:2x4 SP No.1  
BOT CHORD 2x6 SP No.2  
WEBS 2x4 SP No.3 \*Except\* 9-4:2x4 SP No.2  
OTHERS 2x4 SP No.3  
WEDGE Left: 2x6 SP No.2

**BRACING**  
TOP CHORD 2-0-0 oc purlins, except end verticals.  
BOT CHORD Rigid ceiling directly applied or 6-0-0 oc bracing.  
WEBS 1 Row at midpt 3-10, 4-10, 4-9, 7-8

**REACTIONS** (size) 1=0-3-8, 8=0-4-0  
Max Horiz 1=337 (LC 8)  
Max Uplift 1=624 (LC 8), 8=728 (LC 8)  
Max Grav 1=2020 (LC 1), 8=2134 (LC 1)

**FORCES** (lb) - Maximum Compression/Maximum Tension  
TOP CHORD 7-8=-1889/660, 1-4=-2488/726, 4-5=-720/335, 5-7=-989/372  
BOT CHORD 1-12=-799/1888, 10-12=-792/1861, 9-10=-397/1054, 8-9=-4/2  
WEBS 3-12=-257/945, 3-10=-1126/531, 4-10=-544/1437, 4-9=-937/410, 5-9=-164/381, 7-9=-473/1389

**NOTES**  
1) Unbalanced roof live loads have been considered for this design.  
2) Designed to ASCE 7-22 basic load combinations for allowable stress design unless otherwise noted.  
3) Wind: ASCE 7-22; Vult=130mph (3-second gust) Vasd=101mph; TC DL=4.2psf; BCDL=3.0psf; h=18ft; Cat. II; Exp B; Enclosed; MWFRS (envelope) exterior (2) zone; Lumber DOL=1.60 plate grip DOL=1.60  
4) Truss designed for wind loads in the plane of the truss only. For studs exposed to wind (normal to the face), see Standard Industry Gable End Details as applicable, or consult qualified building designer as per ANSI/TPI 1.

- Building Designer / Project engineer responsible for verifying applied roof live load shown covers rain loading requirements specific to the use of this truss component.
- Provide adequate drainage to prevent water ponding.
- All plates are 2x4 (||) MT20 unless otherwise indicated.
- Gable studs spaced at 2-0-0 oc.
- This truss has been designed for a 10.0 psf bottom chord live load nonconcurrent with any other live loads.
- \* This truss has been designed for a live load of 20.0psf on the bottom chord in all areas where a rectangle 3-06-00 tall by 2-00-00 wide will fit between the bottom chord and any other members, with BCDL = 10.0psf.
- Provide mechanical connection (by others) of truss to bearing plate capable of withstanding 624 lb uplift at joint 1 and 728 lb uplift at joint 8.
- Graphical purlin representation does not depict the size or the orientation of the purlin along the top and/or bottom chord.
- "NAILED" indicates 3-10d (0.148"x3") or 3-12d (0.148"x3.25") toe-nails per NDS guidelines.
- In the LOAD CASE(S) section, loads applied to the face of the truss are noted as front (F) or back (B).

**LOAD CASE(S)** Standard  
1) Dead + Roof Live (balanced): Lumber Increase=1.25, Plate Increase=1.25  
Uniform Loads (lb/ft)  
Vert: 1-4=-60, 4-5=-60, 5-7=-60, 1-8=-20  
Concentrated Loads (lb)  
Vert: 39=-217 (F), 40=-217 (F), 42=-217 (F), 43=-217 (F), 45=-217 (F), 46=-217 (F), 47=-217 (F), 48=-217 (F), 50=-217 (F), 51=-217 (F), 53=-217 (F)

This item has been digitally signed and sealed by O'Regan, Philip, PE on the date indicated here. Printed copies of this document are not considered signed and sealed and the signature must be verified on any electronic copies.

Philip J. O'Regan PE No.58126  
MiTek Inc. DBA MiTek USA FL Cert 6634  
16023 Swingley Ridge Rd. Chesterfield, MO 63017  
Date:

May 22, 2026

**WARNING - Verify design parameters and READ NOTES ON THIS AND INCLUDED MITEK REFERENCE PAGE MII-7473 rev. 1/2/2023 BEFORE USE.**

Design valid for use only with MiTek® connectors. This design is based only upon parameters shown, and is for an individual building component, not a truss system. Before use, the building designer must verify the applicability of design parameters and properly incorporate this design into the overall building design. Bracing indicated is to prevent buckling of individual truss web and/or chord members only. Additional temporary and permanent bracing is always required for stability and to prevent collapse with possible personal injury and property damage. For general guidance regarding the fabrication, storage, delivery, erection and bracing of trusses and truss systems, see **ANSI/TPI1 Quality Criteria and DSB-22** available from Truss Plate Institute (www.tpinst.org) and **BCSI Building Component Safety Information** available from the Structural Building Component Association (www.sbcsccomponents.com)

**MiTek®**  
16023 Swingley Ridge Rd.  
Chesterfield, MO 63017  
314.434.1200 / MiTek-US.com

Job 5449020	Truss T22	Truss Type Piggyback Base	Qty 1	Ply 1	Job Reference (optional) T41274319
----------------	--------------	------------------------------	----------	----------	---------------------------------------

Builders FirstSource (Lake City,FL), Lake City, FL - 32055,

Run: 25.40 S Apr 17 2026 Print: 25.4.0 S Apr 17 2026 MiTek Industries, Inc. Wed May 20 15:14:33

Page: 1

ID:R9lyHCWhn3pTTB7RQjPj3qzEbsH-RfC?PsB70Hq3NSgPqnL8w3uITXbGKWrCDoi7J4zJC?f

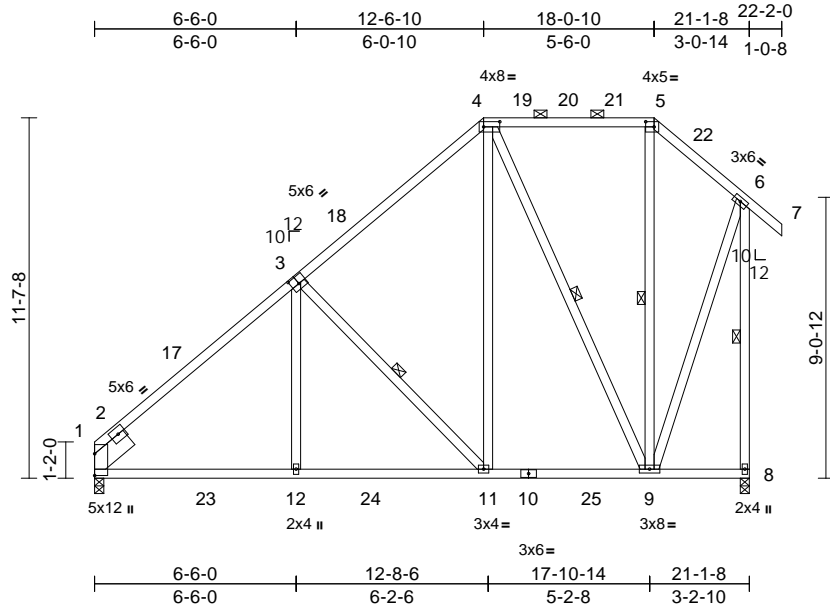

Scale = 1:74.3

Plate Offsets (X, Y): [3:0-3-0,0-3-0], [4:0-6-4,0-2-0], [5:0-3-4,0-2-0]

Loading	(psf)	Spacing	2-0-0	CSI	DEFL	in	(loc)	l/defl	L/d	PLATES	GRIP	
TCLL (roof)	20.0	Plate Grip DOL	1.25	TC	0.54	Vert(LL)	-0.07	11-12	>999	240	MT20	244/190
TCDL	10.0	Lumber DOL	1.25	BC	0.61	Vert(CT)	-0.13	11-12	>999	180		
BCLL	0.0*	Rep Stress Incr	YES	WB	0.42	Horz(CT)	-0.03	1	n/a	n/a		
BCDL	10.0	Code	FBC2023/TPI2014	Matrix-MS							Weight: 176 lb	FT = 20%

**LUMBER**

- TOP CHORD 2x4 SP No.2
- BOT CHORD 2x4 SP No.2
- WEBS 2x4 SP No.3 \*Except\* 9-4:2x4 SP No.2
- SLIDER Left 2x8 SP 2400F 2.0E -- 1-6-0

**BRACING**

- TOP CHORD Structural wood sheathing directly applied, except end verticals, and 2-0-0 oc purlins: 4-5.
- BOT CHORD Rigid ceiling directly applied or 9-4-8 oc bracing.
- WEBS 1 Row at midpt 3-11, 4-9, 5-9, 6-8

**REACTIONS**

- (size) 1=0-3-8, 8=0-3-8
- Max Horiz 1=335 (LC 12)
- Max Uplift 1=-156 (LC 12), 8=-267 (LC 12)
- Max Grav 1=975 (LC 19), 8=1011 (LC 2)

**FORCES**

- (lb) - Maximum Compression/Maximum Tension
- TOP CHORD 1-4=-1063/197, 4-5=-228/145, 5-6=-343/143, 6-7=0/46, 6-8=-975/273
- BOT CHORD 1-12=-424/851, 11-12=-363/851, 9-11=-155/484, 8-9=0/2
- WEBS 3-12=0/310, 3-11=-532/299, 4-11=-168/632, 4-9=-593/230, 5-9=-129/88, 6-9=-170/698

**NOTES**

- 1) Unbalanced roof live loads have been considered for this design.
- 2) Designed to ASCE 7-22 basic load combinations for allowable stress design unless otherwise noted.
- 3) Wind: ASCE 7-22; Vult=130mph (3-second gust) Vasd=101mph; TC DL=4.2psf; BCDL=3.0psf; h=18ft; Cat. II; Exp B; Enclosed; MWFRS (envelope) exterior (2) zone and C-C Zone3 0-0-0 to 3-0-0, Zone1 3-0-0 to 12-6-10, Zone2 12-6-10 to 16-9-8, Zone1 16-9-8 to 18-0-10, Zone3 18-0-10 to 22-2-0 zone;C-C for members and forces & MWFRS for reactions shown; Lumber DOL=1.60 plate grip DOL=1.60

- 4) Building Designer / Project engineer responsible for verifying applied roof live load shown covers rain loading requirements specific to the use of this truss component.
- 5) Provide adequate drainage to prevent water ponding.
- 6) This truss has been designed for a 10.0 psf bottom chord live load nonconcurrent with any other live loads.
- 7) \* This truss has been designed for a live load of 20.0psf on the bottom chord in all areas where a rectangle 3-06-00 tall by 2-00-00 wide will fit between the bottom chord and any other members, with BCDL = 10.0psf.
- 8) Provide mechanical connection (by others) of truss to bearing plate capable of withstanding 267 lb uplift at joint 8 and 156 lb uplift at joint 1.
- 9) Graphical purlin representation does not depict the size or the orientation of the purlin along the top and/or bottom chord.

**LOAD CASE(S)** Standard

This item has been digitally signed and sealed by O'Regan, Philip, PE on the date indicated here. Printed copies of this document are not considered signed and sealed and the signature must be verified on any electronic copies.

Philip J. O'Regan PE No.58126  
MiTek Inc. DBA MiTek USA FL Cert 6634  
16023 Swingley Ridge Rd. Chesterfield, MO 63017  
Date:

May 22,2026

**WARNING - Verify design parameters and READ NOTES ON THIS AND INCLUDED MITEK REFERENCE PAGE MII-7473 rev. 1/2/2023 BEFORE USE.**

Design valid for use only with MiTek® connectors. This design is based only upon parameters shown, and is for an individual building component, not a truss system. Before use, the building designer must verify the applicability of design parameters and properly incorporate this design into the overall building design. Bracing indicated is to prevent buckling of individual truss web and/or chord members only. Additional temporary and permanent bracing is always required for stability and to prevent collapse with possible personal injury and property damage. For general guidance regarding the fabrication, storage, delivery, erection and bracing of trusses and truss systems, see **ANSI/TPI1 Quality Criteria and DSB-22** available from Truss Plate Institute (www.tpinst.org) and **BCSI Building Component Safety Information** available from the Structural Building Component Association (www.sbcsccomponents.com)

**MiTek®**

16023 Swingley Ridge Rd.  
Chesterfield, MO 63017  
314.434.1200 / MiTek-US.com

Job 5449020	Truss T23	Truss Type Piggyback Base	Qty 6	Ply 1	Job Reference (optional)	T41274320
----------------	--------------	------------------------------	----------	----------	--------------------------	-----------

Builders FirstSource (Lake City,FL), Lake City, FL - 32055,

Run: 25.40 S Apr 17 2026 Print: 25.4.0 S Apr 17 2026 MiTek Industries, Inc. Wed May 20 15:14:33

Page: 1

ID:d51PIPgaB7dgvjsM3kWGavzEbrJ-RfC?PsB70Hq3NSgPqnL8w3uITxBGKwrcDoi7J4zJC7f

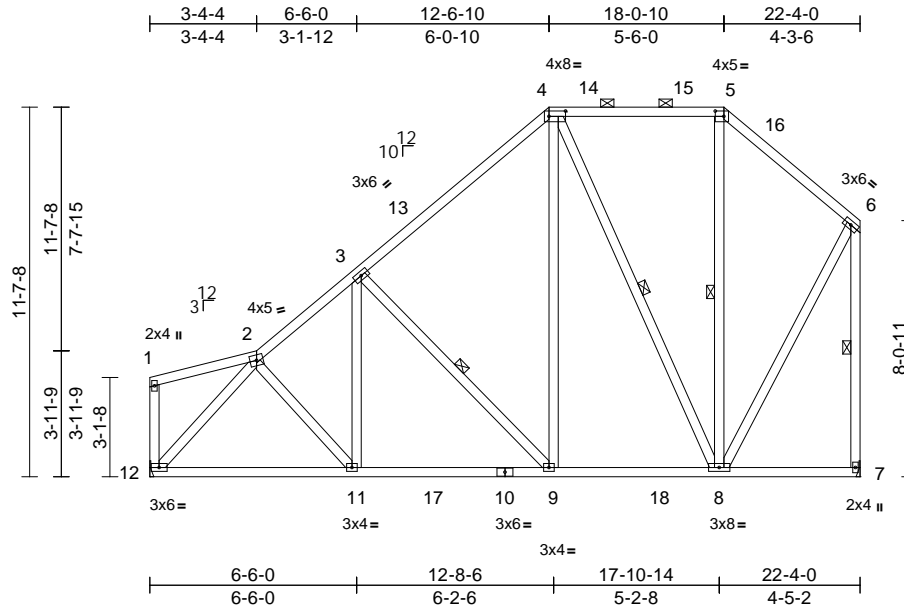

Scale = 1:72.5

Plate Offsets (X, Y): [4:0-6-4,0-2-0], [5:0-3-4,0-2-0]

Loading	(psf)	Spacing	2-0-0	CSI	DEFL	in	(loc)	l/defl	L/d	PLATES	GRIP	
TCLL (roof)	20.0	Plate Grip DOL	1.25	TC	0.39	Vert(LL)	-0.05	9-11	>999	240	MT20	244/190
TCDL	10.0	Lumber DOL	1.25	BC	0.44	Vert(CT)	-0.09	11-12	>999	180		
BCLL	0.0*	Rep Stress Incr	YES	WB	0.49	Horz(CT)	0.02	7	n/a	n/a		
BCDL	10.0	Code	FBC2023/TPI2014	Matrix-MS							Weight: 187 lb	FT = 20%

**LUMBER**  
TOP CHORD 2x4 SP No.2  
BOT CHORD 2x4 SP No.2  
WEBS 2x4 SP No.3 \*Except\* 8-4:2x4 SP No.2

**BRACING**  
TOP CHORD Structural wood sheathing directly applied, except end verticals, and 2-0-0 oc purlins: 4-5.  
BOT CHORD Rigid ceiling directly applied or 9-10-8 oc bracing.  
WEBS 1 Row at midpt 3-9, 4-8, 5-8, 6-7

**REACTIONS**  
(size) 7= Mechanical, 12= Mechanical  
Max Horiz 12=250 (LC 12)  
Max Uplift 7=-213 (LC 12), 12=-160 (LC 12)  
Max Grav 7=982 (LC 2), 12=978 (LC 2)

**FORCES**  
(lb) - Maximum Compression/Maximum Tension  
TOP CHORD 1-2=-49/29, 2-3=-1002/257, 3-4=-744/274, 4-5=-314/234, 5-6=-470/207, 6-7=-923/319, 1-12=-109/80  
BOT CHORD 11-12=-357/769, 9-11=-322/834, 8-9=-143/516, 7-8=-5/6  
WEBS 3-9=-462/257, 4-9=-150/569, 4-8=-490/187, 5-8=-118/108, 6-8=-128/645, 3-11=-1/251, 2-11=-1/101, 2-12=-1046/248

- Building Designer / Project engineer responsible for verifying applied roof live load shown covers rain loading requirements specific to the use of this truss component.
- Provide adequate drainage to prevent water ponding.
- This truss has been designed for a 10.0 psf bottom chord live load nonconcurrent with any other live loads.
- \* This truss has been designed for a live load of 20.0psf on the bottom chord in all areas where a rectangle 3-06-00 tall by 2-00-00 wide will fit between the bottom chord and any other members, with BCDL = 10.0psf.
- Refer to girder(s) for truss to truss connections.
- Provide mechanical connection (by others) of truss to bearing plate capable of withstanding 213 lb uplift at joint 7 and 160 lb uplift at joint 12.
- Graphical purlin representation does not depict the size or the orientation of the purlin along the top and/or bottom chord.

**LOAD CASE(S)** Standard

**NOTES**

- Unbalanced roof live loads have been considered for this design.
- Designed to ASCE 7-22 basic load combinations for allowable stress design unless otherwise noted.
- Wind: ASCE 7-22; Vult=130mph (3-second gust) Vasd=101mph; TC DL=4.2psf; BCDL=3.0psf; h=18ft; Cat. II; Exp B; Enclosed; MWFRS (envelope) exterior (2) zone and C-C Zone3 11-1-12 to 14-4-4, Zone1 14-4-4 to 23-6-10, Zone2 23-6-10 to 27-9-8, Zone1 27-9-8 to 29-0-10, Zone3 29-0-10 to 33-2-4 zone;C-C for members and forces & MWFRS for reactions shown; Lumber DOL=1.60 plate grip DOL=1.60

This item has been digitally signed and sealed by O'Regan, Philip, PE on the date indicated here. Printed copies of this document are not considered signed and sealed and the signature must be verified on any electronic copies.

Philip J. O'Regan PE No.58126  
MiTek Inc. DBA MiTek USA FL Cert 6634  
16023 Swingley Ridge Rd. Chesterfield, MO 63017  
Date:

May 22, 2026

**WARNING - Verify design parameters and READ NOTES ON THIS AND INCLUDED MITEK REFERENCE PAGE MII-7473 rev. 1/2/2023 BEFORE USE.**

Design valid for use only with MiTek® connectors. This design is based only upon parameters shown, and is for an individual building component, not a truss system. Before use, the building designer must verify the applicability of design parameters and properly incorporate this design into the overall building design. Bracing indicated is to prevent buckling of individual truss web and/or chord members only. Additional temporary and permanent bracing is always required for stability and to prevent collapse with possible personal injury and property damage. For general guidance regarding the fabrication, storage, delivery, erection and bracing of trusses and truss systems, see **ANSI/TPI1 Quality Criteria and DSB-22** available from Truss Plate Institute (www.tpinst.org) and **BCSI Building Component Safety Information** available from the Structural Building Component Association (www.sbcsccomponents.com)

**MiTek®**

16023 Swingley Ridge Rd.  
Chesterfield, MO 63017  
314.434.1200 / MiTek-US.com



Job 5449020	Truss T24	Truss Type Piggyback Base	Qty 5	Ply 1	Job Reference (optional) T41274322
----------------	--------------	------------------------------	----------	----------	---------------------------------------

Builders FirstSource (Lake City,FL), Lake City, FL - 32055,

Run: 25.40 S Apr 17 2026 Print: 25.4.0 S Apr 17 2026 MiTek Industries, Inc. Wed May 20 15:14:33  
ID:UQX40ST7HLrpXpzjyLK1UzEbbe-RfC?PsB70Hq3NSgPqnL8w3uITxBGKWrCDoi7J4zJC7f

Page: 1

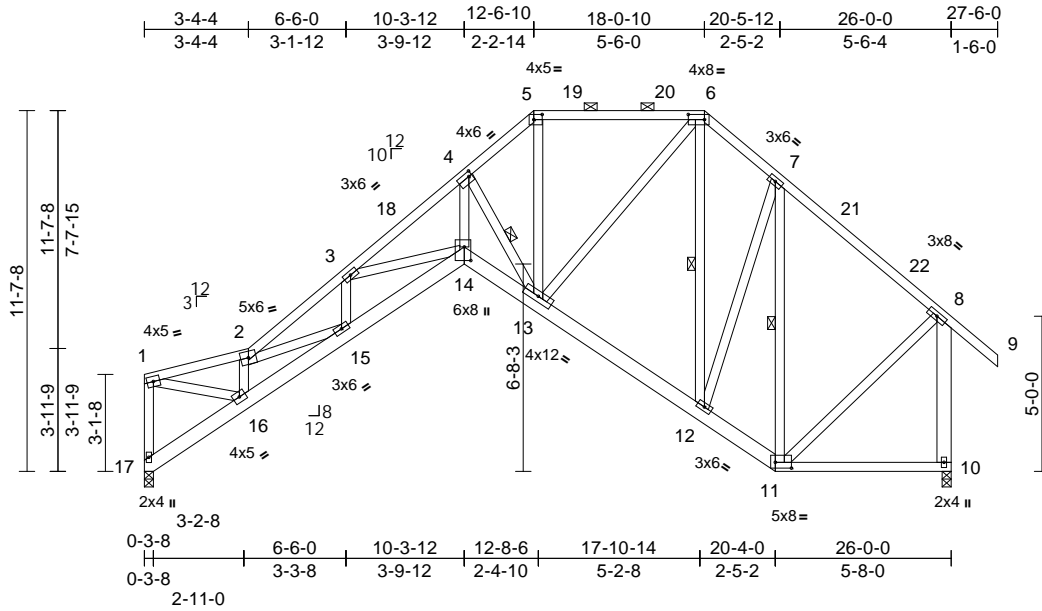

Scale = 1:74.2

Plate Offsets (X, Y): [4:0-1-4,0-1-12], [5:0-3-4,0-2-0], [6:0-6-4,0-2-0], [11:0-6-4,0-2-4], [14:0-5-4,0-2-8]

Loading	(psf)	Spacing	2-0-0	CSI	DEFL	in	(loc)	l/defl	L/d	PLATES	GRIP	
TCLL (roof)	20.0	Plate Grip DOL	1.25	TC	0.47	Vert(LL)	-0.20	14-15	>999	240	MT20	244/190
TCDL	10.0	Lumber DOL	1.25	BC	0.62	Vert(CT)	-0.40	14-15	>775	180		
BCLL	0.0*	Rep Stress Incr	YES	WB	0.69	Horz(CT)	0.49	10	n/a	n/a		
BCDL	10.0	Code	FBC2023/TPI2014	Matrix-MS							Weight: 229 lb	FT = 20%

**LUMBER**  
TOP CHORD 2x4 SP No.2  
BOT CHORD 2x6 SP No.2 \*Except\* 11-10:2x4 SP No.2  
WEBS 2x4 SP No.3 \*Except\* 10-8:2x6 SP No.2, 4-14:2x4 SP No.2

**BRACING**  
TOP CHORD Structural wood sheathing directly applied, except end verticals, and 2-0-0 oc purlins: 5-6.  
BOT CHORD Rigid ceiling directly applied or 7-3-15 oc bracing.  
WEBS 1 Row at midpt 6-12, 7-11, 4-13

**REACTIONS** (size) 10=0-3-8, 17=0-3-8  
Max Horiz 17=327 (LC 11)  
Max Uplift 10=221 (LC 13), 17=220 (LC 12)  
Max Grav 10=1132 (LC 1), 17=1021 (LC 1)

**FORCES** (lb) - Maximum Compression/Maximum Tension  
TOP CHORD 1-17=-969/267, 1-2=-1792/459, 2-3=-3227/828, 3-4=-3101/821, 4-5=-1427/461, 5-6=-1096/390, 6-7=-811/339, 7-8=-729/265, 8-9=0/66, 8-10=-1078/374  
BOT CHORD 16-17=-405/304, 15-16=-852/2310, 14-15=-1015/3036, 13-14=-921/2771, 12-13=-205/728, 11-12=-126/575, 10-11=-54/76  
WEBS 1-16=-434/1752, 2-16=-1655/451, 5-13=-187/646, 6-13=-308/832, 6-12=-368/251, 7-12=-193/369, 7-11=-644/158, 8-11=-100/612, 3-14=-201/272, 4-14=-1013/3129, 4-13=-2588/845, 3-15=-182/78, 2-15=-143/631

**NOTES**  
1) Unbalanced roof live loads have been considered for this design.  
2) Designed to ASCE 7-22 basic load combinations for allowable stress design unless otherwise noted.

- Wind: ASCE 7-22; Vult=130mph (3-second gust) Vasd=101mph; TCCL=4.2psf; BCDL=3.0psf; h=18ft; Cat. II; Exp B; Enclosed; MWFRS (envelope) exterior (2) zone and C-C Zone3 0-1-12 to 3-4-4, Zone1 3-4-4 to 12-6-10, Zone2 12-6-10 to 16-9-8, Zone1 16-9-8 to 18-0-10, Zone2 18-0-10 to 22-3-8, Zone1 22-3-8 to 27-6-0 zone; end vertical right exposed; C-C for members and forces & MWFRS for reactions shown; Lumber DOL=1.60 plate grip DOL=1.60
- Building Designer / Project engineer responsible for verifying applied roof live load shown covers rain loading requirements specific to the use of this truss component.
- Provide adequate drainage to prevent water ponding.
- This truss has been designed for a 10.0 psf bottom chord live load nonconcurrent with any other live loads.
- \* This truss has been designed for a live load of 20.0psf on the bottom chord in all areas where a rectangle 3-06-00 tall by 2-00-00 wide will fit between the bottom chord and any other members.
- Bearing at joint(s) 17 considers parallel to grain value using ANSI/TPI 1 angle to grain formula. Building designer should verify capacity of bearing surface.
- Provide mechanical connection (by others) of truss to bearing plate capable of withstanding 220 lb uplift at joint 17 and 221 lb uplift at joint 10.
- Graphical purlin representation does not depict the size or the orientation of the purlin along the top and/or bottom chord.

**LOAD CASE(S)** Standard

This item has been digitally signed and sealed by O'Regan, Philip, PE on the date indicated here. Printed copies of this document are not considered signed and sealed and the signature must be verified on any electronic copies.

Philip J. O'Regan PE No.58126  
MiTek Inc. DBA MiTek USA FL Cert 6634  
16023 Swingley Ridge Rd. Chesterfield, MO 63017  
Date:

May 22, 2026

**WARNING - Verify design parameters and READ NOTES ON THIS AND INCLUDED MITEK REFERENCE PAGE MII-7473 rev. 1/2/2023 BEFORE USE.**

Design valid for use only with MiTek® connectors. This design is based only upon parameters shown, and is for an individual building component, not a truss system. Before use, the building designer must verify the applicability of the design parameters and properly incorporate this design into the overall building design. Bracing indicated is to prevent buckling of individual truss web and/or chord members only. Additional temporary and permanent bracing is always required for stability and to prevent collapse with possible personal injury and property damage. For general guidance regarding the fabrication, storage, delivery, erection and bracing of trusses and truss systems, see **ANSI/TPI1 Quality Criteria and DSB-22** available from Truss Plate Institute (www.tpinst.org) and **BCSI Building Component Safety Information** available from the Structural Building Component Association (www.sbcsccomponents.com)

**MiTek®**

16023 Swingley Ridge Rd.  
Chesterfield, MO 63017  
314.434.1200 / MiTek-US.com

Job 5449020	Truss T24D	Truss Type Piggyback Base	Qty 5	Ply 1	Job Reference (optional) T41274323
----------------	---------------	------------------------------	----------	----------	---------------------------------------

Builders FirstSource (Lake City,FL), Lake City, FL - 32055,

Run: 25.40 S Apr 17 2026 Print: 25.4.0 S Apr 17 2026 MiTek Industries, Inc. Wed May 20 15:14:34  
ID:UQX40ST7HLrPxzjyLK1UzEbte-RfC?PsB70Hq3NSgPqnL8w3uITxBGKWrCDoi7J4zJC7f

Page: 1

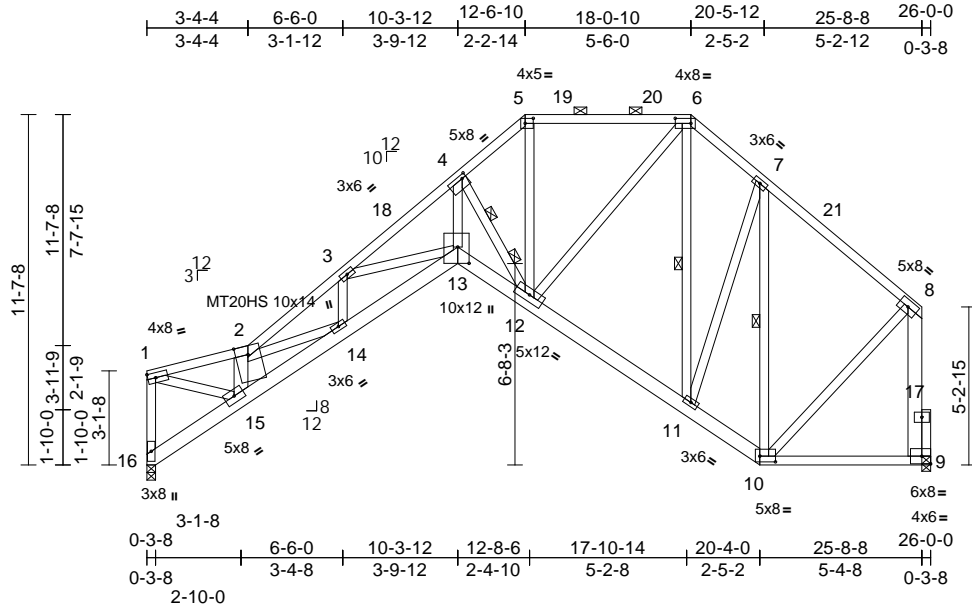

Scale = 1:76.4

Plate Offsets (X, Y): [4:0-1-12,0-1-8], [5:0-3-4,0-2-0], [6:0-6-4,0-2-0], [10:0-6-4,0-2-4], [13:0-6-8,0-4-8]

Loading	(psf)	Spacing	2-0-0	CSI	DEFL	in	(loc)	l/defl	L/d	PLATES	GRIP	
TCLL (roof)	20.0	Plate Grip DOL	1.25	TC	0.92	Vert(LL)	0.33	13-14	>922	240	MT20	244/190
TCDL	10.0	Lumber DOL	1.25	BC	0.52	Vert(CT)	-0.66	13-14	>464	180	MT20HS	187/143
BCLL	0.0*	Rep Stress Incr	NO	WB	0.96	Horz(CT)	0.80	9	n/a	n/a		
BCDL	10.0	Code	FBC2023/TPI2014	Matrix-MS								Weight: 230 lb FT = 20%

**LUMBER**

TOP CHORD 2x4 SP No.2 \*Except\* 2-5:2x4 SP No.1

BOT CHORD 2x6 SP 2400F 2.0E or 2x6 SP M 26 \*Except\* 10-9:2x4 SP No.2

WEBS 2x4 SP No.3 \*Except\* 15-1:2x4 SP No.2, 15-2,9-8:2x6 SP No.2, 4-13:2x4 SP No.1

**OTHERS**

2x4 SP No.2

**BRACING**

TOP CHORD Structural wood sheathing directly applied, except end verticals, and 2-0-0 oc purlins: 5-6.

BOT CHORD Rigid ceiling directly applied or 6-0-0 oc bracing.

WEBS 1 Row at midpt 6-11, 7-10

WEBS 2 Rows at 1/3 pts 4-12

**REACTIONS** (size) 9=0-3-8, 16=0-3-8

Max Horiz 16=318 (LC 11)

Max Uplift 9=-466 (LC 12), 16=-535 (LC 12)

Max Grav 9=1938 (LC 1), 16=2077 (LC 1)

**FORCES** (lb) - Maximum Compression/Maximum Tension

TOP CHORD 1-16=-1982/769, 1-2=-3405/1309, 2-3=-6407/2504, 3-4=-5890/2331, 4-5=-2676/1117, 5-6=-1996/880, 6-7=-1532/703, 7-8=-1409/554, 8-9=-1888/762

BOT CHORD 15-16=-396/277, 14-15=-1908/4645, 13-14=-2402/5992, 12-13=-2057/5230, 11-12=-475/1280, 10-11=-436/1063, 9-10=-114/164

WEBS 1-15=-1278/3331, 2-15=-3443/1374, 5-12=-542/1328, 6-12=-578/1551, 6-11=-543/319, 7-11=-241/482, 7-10=-1259/516, 8-10=-360/1084, 3-13=-536/363, 4-13=-2319/5934, 4-12=-5039/2054, 3-14=-379/189, 2-14=-436/1183

- Unbalanced roof live loads have been considered for this design.
  - Designed to ASCE 7-22 basic load combinations for allowable stress design unless otherwise noted.
  - Wind: ASCE 7-22; Vult=130mph (3-second gust) Vasd=101mph; TC DL=4.2psf; BCDL=3.0psf; h=18ft; Cat. II; Exp B; Enclosed; MWFRS (envelope) exterior (2) zone and C-C Zone3 0-1-12 to 3-4-4, Zone1 3-4-4 to 12-6-10, Zone2 12-6-10 to 16-9-8, Zone1 16-9-8 to 18-0-10, Zone2 18-0-10 to 22-3-8, Zone1 22-3-8 to 25-5-12 zone; end vertical right exposed; C-C for members and forces & MWFRS for reactions shown; Lumber DOL=1.60 plate grip DOL=1.60
  - Building Designer / Project engineer responsible for verifying applied roof live load shown covers rain loading requirements specific to the use of this truss component.
  - Provide adequate drainage to prevent water ponding.
  - All plates are MT20 plates unless otherwise indicated.
  - This truss has been designed for a 10.0 psf bottom chord live load nonconcurrent with any other live loads.
  - \* This truss has been designed for a live load of 20.0psf on the bottom chord in all areas where a rectangle 3-06-00 tall by 2-00-00 wide will fit between the bottom chord and any other members.
  - Bearing at joint(s) 16 considers parallel to grain value using ANSI/TPI 1 angle to grain formula. Building designer should verify capacity of bearing surface.
  - Provide mechanical connection (by others) of truss to bearing plate capable of withstanding 535 lb uplift at joint 16 and 466 lb uplift at joint 9.
  - Graphical purlin representation does not depict the size or the orientation of the purlin along the top and/or bottom chord.
  - In the LOAD CASE(S) section, loads applied to the face of the truss are noted as front (F) or back (B).
- LOAD CASE(S)** Standard
- Dead + Roof Live (balanced): Lumber Increase=1.25, Plate Increase=1.25 Uniform Loads (lb/ft)

Vert: 1-2=-160, 2-5=-160, 5-6=-60, 6-8=-160 (F=-100), 13-16=-20, 10-13=-20, 9-10=-20

This item has been digitally signed and sealed by O'Regan, Philip, PE on the date indicated here. Printed copies of this document are not considered signed and sealed and the signature must be verified on any electronic copies.

Philip J. O'Regan PE No.58126  
MiTek Inc. DBA MiTek USA FL Cert 6634  
16023 Swingley Ridge Rd. Chesterfield, MO 63017  
Date:

May 22, 2026

**NOTES**

**WARNING - Verify design parameters and READ NOTES ON THIS AND INCLUDED MITEK REFERENCE PAGE MII-7473 rev. 1/2/2023 BEFORE USE.**

Design valid for use only with MiTek® connectors. This design is based only upon parameters shown, and is for an individual building component, not a truss system. Before use, the building designer must verify the applicability of the design parameters and properly incorporate this design into the overall building design. Bracing indicated is to prevent buckling of individual truss web and/or chord members only. Additional temporary and permanent bracing is always required for stability and to prevent collapse with possible personal injury and property damage. For general guidance regarding the fabrication, storage, delivery, erection and bracing of trusses and truss systems, see **ANSI/TPI1 Quality Criteria and DSB-22** available from Truss Plate Institute (www.tpinst.org) and **BCSI Building Component Safety Information** available from the Structural Building Component Association (www.sbcsccomponents.com)

**MiTek®**  
16023 Swingley Ridge Rd.  
Chesterfield, MO 63017  
314.434.1200 / MiTek-US.com

Job 5449020	Truss T25	Truss Type Scissor	Qty 2	Ply 1	Job Reference (optional) T41274324
----------------	--------------	-----------------------	----------	----------	---------------------------------------

Builders FirstSource (Lake City,FL), Lake City, FL - 32055,

Run: 25.40 S Apr 17 2026 Print: 25.4.0 S Apr 17 2026 MiTek Industries, Inc. Wed May 20 15:14:34

Page: 1

ID:oufAnpYS\_JxKVA8gfs?9\_hzEcVZ-RfC?PsB70Hq3NSgPqnL8w3uITXbGKWrCDoi7J4zJC?f

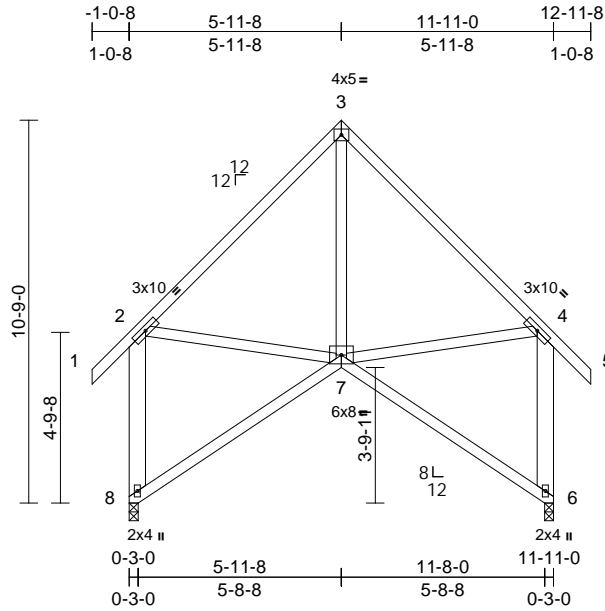

Scale = 1:64.7

Loading	(psf)	Spacing	2-0-0	CSI	DEFL	in	(loc)	l/defl	L/d	PLATES	GRIP
TCLL (roof)	20.0	Plate Grip DOL	1.25	TC	0.37	Vert(LL)	-0.04	6-7	>999	240	244/190
TCDL	10.0	Lumber DOL	1.25	BC	0.26	Vert(CT)	-0.08	6-7	>999	180	
BCLL	0.0*	Rep Stress Incr	YES	WB	0.13	Horz(CT)	0.02	6	n/a	n/a	
BCDL	10.0	Code	FBC2023/TPI2014	Matrix-MS						Weight: 99 lb	FT = 20%

**LUMBER**

TOP CHORD 2x4 SP No.2  
 BOT CHORD 2x4 SP No.2  
 WEBS 2x4 SP No.3 \*Except\* 8-2,6-4:2x6 SP No.2

**BRACING**

TOP CHORD Structural wood sheathing directly applied, except end verticals.  
 BOT CHORD Rigid ceiling directly applied or 8-11-14 oc bracing.

**REACTIONS**

(size) 6=0-3-0, 8=0-3-0  
 Max Horiz 8=-341 (LC 10)  
 Max Uplift 6=-116 (LC 12), 8=-116 (LC 13)  
 Max Grav 6=535 (LC 1), 8=535 (LC 1)

**FORCES**

(lb) - Maximum Compression/Maximum Tension

TOP CHORD 1-2=0/54, 2-3=-444/216, 3-4=-503/215,  
 4-5=0/54, 2-8=-514/234, 4-6=-500/278  
 BOT CHORD 7-8=-409/407, 6-7=-109/149  
 WEBS 3-7=-162/294, 2-7=0/197, 4-7=-179/321

**NOTES**

- Unbalanced roof live loads have been considered for this design.
- Designed to ASCE 7-22 basic load combinations for allowable stress design unless otherwise noted.
- Wind: ASCE 7-22; Vult=130mph (3-second gust) Vasd=101mph; TCDL=4.2psf; BCDL=3.0psf; h=18ft; Cat. II; Exp B; Enclosed; MWFRS (envelope) exterior (2) zone and C-C Zone1 zone; end vertical left and right exposed; C-C for members and forces & MWFRS for reactions shown; Lumber DOL=1.60 plate grip DOL=1.60
- Building Designer / Project engineer responsible for verifying applied roof live load shown covers rain loading requirements specific to the use of this truss component.
- This truss has been designed for a 10.0 psf bottom chord live load nonconcurrent with any other live loads.
- \* This truss has been designed for a live load of 20.0psf on the bottom chord in all areas where a rectangle 3-06-00 tall by 2-00-00 wide will fit between the bottom chord and any other members.

- Bearing at joint(s) 8, 6 considers parallel to grain value using ANSI/TPI 1 angle to grain formula. Building designer should verify capacity of bearing surface.
- Provide mechanical connection (by others) of truss to bearing plate at joint(s) 6.
- Provide mechanical connection (by others) of truss to bearing plate capable of withstanding 116 lb uplift at joint 8 and 116 lb uplift at joint 6.

**LOAD CASE(S)** Standard

This item has been digitally signed and sealed by ORegan, Philip, PE on the date indicated here. Printed copies of this document are not considered signed and sealed and the signature must be verified on any electronic copies.

Philip J. O'Regan PE No.58126  
 MiTek Inc. DBA MiTek USA FL Cert 6634  
 16023 Swingley Ridge Rd. Chesterfield, MO 63017  
 Date:

May 22, 2026

**WARNING - Verify design parameters and READ NOTES ON THIS AND INCLUDED MITEK REFERENCE PAGE MII-7473 rev. 1/2/2023 BEFORE USE.**

Design valid for use only with MiTek® connectors. This design is based only upon parameters shown, and is for an individual building component, not a truss system. Before use, the building designer must verify the applicability of design parameters and properly incorporate this design into the overall building design. Bracing indicated is to prevent buckling of individual truss web and/or chord members only. Additional temporary and permanent bracing is always required for stability and to prevent collapse with possible personal injury and property damage. For general guidance regarding the fabrication, storage, delivery, erection and bracing of trusses and truss systems, see **ANSI/TPI1 Quality Criteria and DSB-22** available from Truss Plate Institute (www.tpinst.org) and **BCSI Building Component Safety Information** available from the Structural Building Component Association (www.sbcsccomponents.com)

**MiTek®**

16023 Swingley Ridge Rd.  
 Chesterfield, MO 63017  
 314.434.1200 / MiTek-US.com

Job 5449020	Truss T25G	Truss Type Scissor Supported Gable	Qty 1	Ply 1	Job Reference (optional) T41274325
----------------	---------------	---------------------------------------	----------	----------	---------------------------------------

Builders FirstSource (Lake City,FL), Lake City, FL - 32055,

Run: 25.40 S Apr 17 2026 Print: 25.4.0 S Apr 17 2026 MiTek Industries, Inc. Wed May 20 15:14:34

Page: 1

ID:R?yfrGivhT?f76RDLz25zEbeP-RfC?PsB70Hq3NSgPqnL8w3ulTXbGKWrdCoI7J4zJC?f

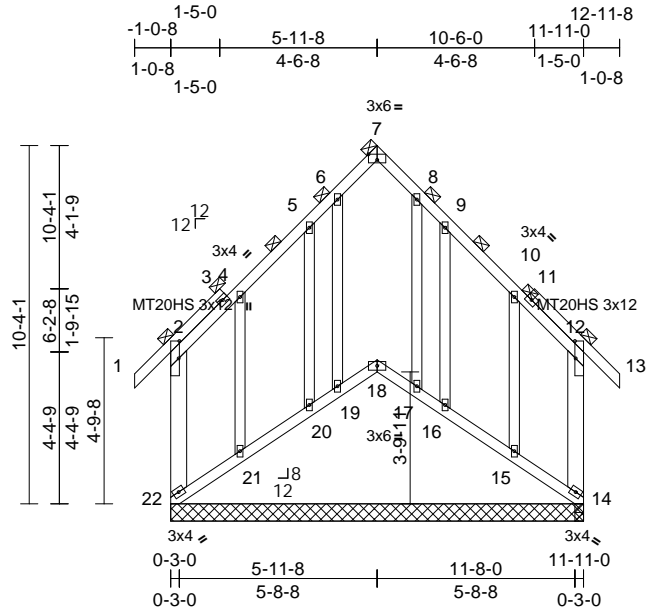

Scale = 1:66.5

Plate Offsets (X, Y): [2:0-6-0,0-0-4], [7:0-3-0,Edge], [12:0-6-0,0-0-4]

Loading	(psf)	Spacing	2-0-0	CSI	DEFL	in	(loc)	l/defl	L/d	PLATES	GRIP	
TCLL (roof)	20.0	Plate Grip DOL	1.25	TC	0.34	Vert(LL)	-0.01	21-22	>999	240	MT20	244/190
TCDL	10.0	Lumber DOL	1.25	BC	0.38	Vert(CT)	-0.01	21-22	>999	180	MT20HS	187/143
BCLL	0.0*	Rep Stress Incr	YES	WB	0.24	Horz(CT)	-0.01	14	n/a	n/a		
BCDL	10.0	Code	FBC2023/TPI2014	Matrix-MR								
											Weight: 125 lb	FT = 20%

**LUMBER**  
TOP CHORD 2x4 SP No.2  
BOT CHORD 2x4 SP No.2  
WEBS 2x6 SP No.2  
OTHERS 2x4 SP No.3

**BRACING**  
TOP CHORD 2-0-0 oc purlins, except end verticals.  
BOT CHORD Rigid ceiling directly applied or 6-0-0 oc bracing.

**REACTIONS** (size)  
14=11-11-0, 15=11-11-0,  
16=11-11-0, 17=11-11-0,  
18=11-11-0, 19=11-11-0,  
20=11-11-0, 21=11-11-0,  
22=11-11-0  
Max Horiz 22=-324 (LC 10)  
Max Uplift 14=-272 (LC 9), 15=-415 (LC 8),  
16=-177 (LC 13), 17=-34 (LC 10),  
18=-213 (LC 11), 19=-42 (LC 11),  
20=-177 (LC 12), 21=-421 (LC 9),  
22=-480 (LC 8)  
Max Grav 14=343 (LC 19), 15=505 (LC 11),  
16=131 (LC 19), 17=234 (LC 12),  
18=219 (LC 8), 19=233 (LC 13),  
20=134 (LC 20), 21=511 (LC 10),  
22=558 (LC 11)

**FORCES** (lb) - Maximum Compression/Maximum Tension  
TOP CHORD 2-22=-302/297, 1-2=0/49, 2-4=-249/247,  
4-5=-104/288, 5-6=-185/513, 6-7=-107/242,  
7-8=-107/242, 8-9=-184/511, 9-10=-106/290,  
10-12=-244/243, 12-13=0/49, 12-14=-298/293  
BOT CHORD 21-22=-299/265, 20-21=-209/201,  
19-20=-238/212, 18-19=-218/206,  
17-18=-223/208, 16-17=-208/196,  
15-16=-247/223, 14-15=-146/153  
WEBS 6-19=-392/94, 8-17=-390/92, 4-21=-290/305,  
5-20=-163/319, 10-15=-287/302,  
9-16=-162/318

**NOTES**

- Unbalanced roof live loads have been considered for this design.
- Designed to ASCE 7-22 basic load combinations for allowable stress design unless otherwise noted.
- Wind: ASCE 7-22; Vult=130mph (3-second gust) Vasd=101mph; TC DL=4.2psf; BC DL=3.0psf; h=18ft; Cat. II; Exp B; Enclosed; MWFRS (envelope) exterior (2) zone and C-C Zone3 zone; end vertical left and right exposed; C-C for members and forces & MWFRS for reactions shown; Lumber DOL=1.60 plate grip DOL=1.60
- Truss designed for wind loads in the plane of the truss only. For studs exposed to wind (normal to the face), see Standard Industry Gable End Details as applicable, or consult qualified building designer as per ANSI/TPI 1.
- Building Designer / Project engineer responsible for verifying applied roof live load shown covers rain loading requirements specific to the use of this truss component.
- All plates are MT20 plates unless otherwise indicated.
- All plates are 2x4 (||) MT20 unless otherwise indicated.
- Truss to be fully sheathed from one face or securely braced against lateral movement (i.e. diagonal web).
- Gable studs spaced at 2-0-0 oc.
- This truss has been designed for a 10.0 psf bottom chord live load nonconcurrent with any other live loads.
- \* This truss has been designed for a live load of 20.0psf on the bottom chord in all areas where a rectangle 3-06-00 tall by 2-00-00 wide will fit between the bottom chord and any other members.
- Provide mechanical connection (by others) of truss to bearing plate capable of withstanding 480 lb uplift at joint 22, 213 lb uplift at joint 18, 272 lb uplift at joint 14, 42 lb uplift at joint 19, 34 lb uplift at joint 17, 421 lb uplift at joint 21, 177 lb uplift at joint 20, 415 lb uplift at joint 15 and 177 lb uplift at joint 16.
- Graphical purlin representation does not depict the size or the orientation of the purlin along the top and/or bottom chord.

**LOAD CASE(S)** Standard

This item has been digitally signed and sealed by O'Regan, Philip, PE on the date indicated here. Printed copies of this document are not considered signed and sealed and the signature must be verified on any electronic copies.

Philip J. O'Regan PE No.58126  
MiTek Inc. DBA MiTek USA FL Cert 6634  
16023 Swingley Ridge Rd. Chesterfield, MO 63017  
Date:

May 22, 2026

**WARNING - Verify design parameters and READ NOTES ON THIS AND INCLUDED MITEK REFERENCE PAGE MII-7473 rev. 1/2/2023 BEFORE USE.**

Design valid for use only with MiTek® connectors. This design is based only upon parameters shown, and is for an individual building component, not a truss system. Before use, the building designer must verify the applicability of the design parameters and properly incorporate this design into the overall building design. Bracing indicated is to prevent buckling of individual truss web and/or chord members only. Additional temporary and permanent bracing is always required for stability and to prevent collapse with possible personal injury and property damage. For general guidance regarding the fabrication, storage, delivery, erection and bracing of trusses and truss systems, see **ANSI/TPI1 Quality Criteria and DSB-22** available from Truss Plate Institute (www.tpinst.org) and **BCSI Building Component Safety Information** available from the Structural Building Component Association (www.sbcsccomponents.com)

**MiTek®**

16023 Swingley Ridge Rd.  
Chesterfield, MO 63017  
314.434.1200 / MiTek-US.com

Job 5449020	Truss T26	Truss Type Scissor	Qty 3	Ply 1	Job Reference (optional) T41274326
----------------	--------------	-----------------------	----------	----------	---------------------------------------

Builders FirstSource (Lake City,FL), Lake City, FL - 32055,

Run: 25.40 S Apr 17 2026 Print: 25.4.0 S Apr 17 2026 MiTek Industries, Inc. Wed May 20 15:14:34

Page: 1

ID:FWEix1glDaSjSptFm1egR5zEcRX-RfC?PsB70Hq3NSgPqnL8w3uITxBGkWrCDoi7J4zJC?f

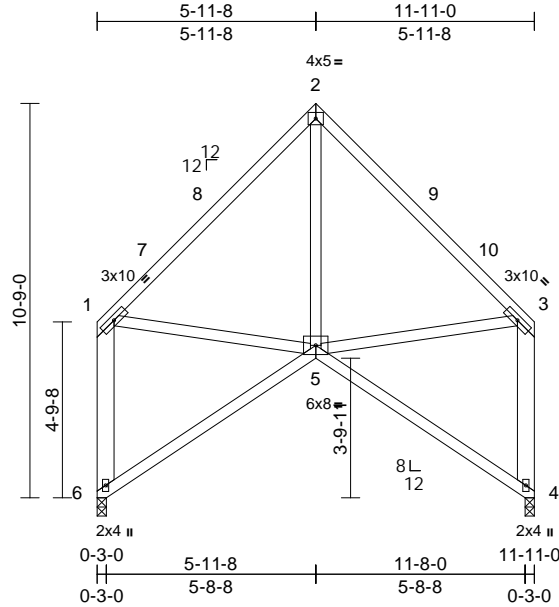

Scale = 1:62.8

Loading	(psf)	Spacing	2-0-0	CSI	DEFL	in	(loc)	l/defl	L/d	PLATES	GRIP
TCLL (roof)	20.0	Plate Grip DOL	1.25	TC	0.42	Vert(LL)	-0.04	5-6	>999	240	244/190
TCDL	10.0	Lumber DOL	1.25	BC	0.26	Vert(CT)	-0.08	5-6	>999	180	
BCLL	0.0*	Rep Stress Incr	YES	WB	0.08	Horz(CT)	0.01	4	n/a	n/a	
BCDL	10.0	Code	FBC2023/TPI2014	Matrix-MS						Weight: 95 lb	FT = 20%

**LUMBER**

- TOP CHORD 2x4 SP No.2
- BOT CHORD 2x4 SP No.2
- WEBS 2x4 SP No.3 \*Except\* 6-1,4-3:2x6 SP No.2

**BRACING**

- TOP CHORD Structural wood sheathing directly applied, except end verticals.
- BOT CHORD Rigid ceiling directly applied or 10-0-0 oc bracing.

**REACTIONS**

- (size) 4=0-3-0, 6=0-3-0
- Max Horiz 6=142 (LC 9)
- Max Uplift 4=-130 (LC 12), 6=-130 (LC 13)
- Max Grav 4=458 (LC 1), 6=458 (LC 1)

**FORCES**

(lb) - Maximum Compression/Maximum Tension

- TOP CHORD 1-2=-434/172, 2-3=-457/174, 1-6=-420/211, 3-4=-420/206
- BOT CHORD 5-6=-197/234, 4-5=-39/90
- WEBS 2-5=-60/218, 1-5=-5/203, 3-5=-88/265

**NOTES**

- Unbalanced roof live loads have been considered for this design.
- Designed to ASCE 7-22 basic load combinations for allowable stress design unless otherwise noted.
- Wind: ASCE 7-22; Vult=130mph (3-second gust) Vasd=101mph; TCDL=4.2psf; BCDL=3.0psf; h=18ft; Cat. II; Exp B; Enclosed; MWFRS (envelope) interior (1) zone and C-C Zone3 0-3-4 to 3-3-4, Zone1 3-3-4 to 6-0-0, Zone2 6-0-0 to 10-2-15, Zone1 10-2-15 to 11-8-12 zone;C-C for members and forces & MWFRS for reactions shown; Lumber DOL=1.60 plate grip DOL=1.60
- Building Designer / Project engineer responsible for verifying applied roof live load shown covers rain loading requirements specific to the use of this truss component.
- This truss has been designed for a 10.0 psf bottom chord live load nonconcurrent with any other live loads.

- \* This truss has been designed for a live load of 20.0psf on the bottom chord in all areas where a rectangle 3-06-00 tall by 2-00-00 wide will fit between the bottom chord and any other members.
- Bearing at joint(s) 6, 4 considers parallel to grain value using ANSI/TPI 1 angle to grain formula. Building designer should verify capacity of bearing surface.
- Provide mechanical connection (by others) of truss to bearing plate at joint(s) 4.
- Provide mechanical connection (by others) of truss to bearing plate capable of withstanding 130 lb uplift at joint 6 and 130 lb uplift at joint 4.

**LOAD CASE(S)** Standard

This item has been digitally signed and sealed by ORegan, Philip, PE on the date indicated here. Printed copies of this document are not considered signed and sealed and the signature must be verified on any electronic copies.

Philip J. O'Regan PE No.58126  
MiTek Inc. DBA MiTek USA FL Cert 6634  
16023 Swingley Ridge Rd. Chesterfield, MO 63017  
Date:

May 22,2026

**WARNING - Verify design parameters and READ NOTES ON THIS AND INCLUDED MITEK REFERENCE PAGE MII-7473 rev. 1/2/2023 BEFORE USE.**

Design valid for use only with MiTek® connectors. This design is based only upon parameters shown, and is for an individual building component, not a truss system. Before use, the building designer must verify the applicability of design parameters and properly incorporate this design into the overall building design. Bracing indicated is to prevent buckling of individual truss web and/or chord members only. Additional temporary and permanent bracing is always required for stability and to prevent collapse with possible personal injury and property damage. For general guidance regarding the fabrication, storage, delivery, erection and bracing of trusses and truss systems, see **ANSI/TPI1 Quality Criteria and DSB-22** available from Truss Plate Institute (www.tpinst.org) and **BCSI Building Component Safety Information** available from the Structural Building Component Association (www.sbcsccomponents.com)

**MiTek®**

16023 Swingley Ridge Rd.  
Chesterfield, MO 63017  
314.434.1200 / MiTek-US.com

Job 5449020	Truss T27	Truss Type Scissor	Qty 2	Ply 1	Job Reference (optional) T41274327
----------------	--------------	-----------------------	----------	----------	---------------------------------------

Builders FirstSource (Lake City,FL), Lake City, FL - 32055,

Run: 25.40 S Apr 17 2026 Print: 25.4.0 S Apr 17 2026 MiTek Industries, Inc. Wed May 20 15:14:34  
ID:7qX4v177GGEK0fnZ70Ja\_6zEcQx-RfC?PsB70Hq3NSgPqnL8w3uITXbGKWRcDoi7J4zJC7f

Page: 1

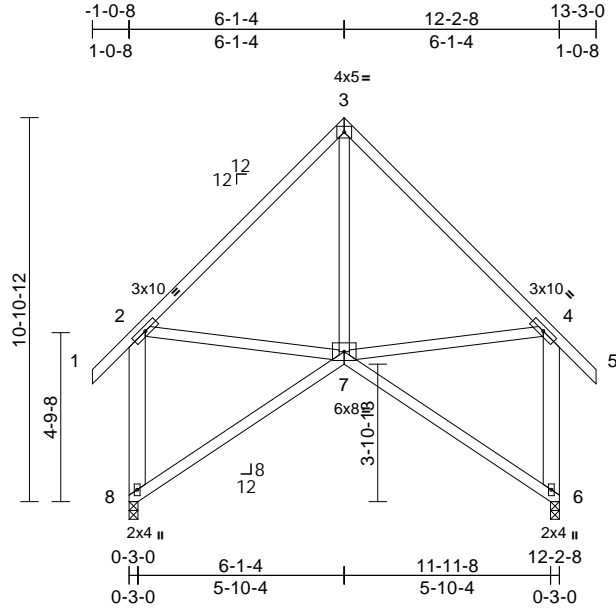

Scale = 1:65.4

Plate Offsets (X, Y): [4:0-0-0,0-0-0]

Loading	(psf)	Spacing	2-0-0	CSI	DEFL	in	(loc)	l/defl	L/d	PLATES	GRIP	
TCLL (roof)	20.0	Plate Grip DOL	1.25	TC	0.39	Vert(LL)	-0.04	7-8	>999	240	MT20	244/190
TCDL	10.0	Lumber DOL	1.25	BC	0.27	Vert(CT)	-0.09	7-8	>999	180		
BCLL	0.0*	Rep Stress Incr	YES	WB	0.13	Horz(CT)	0.02	6	n/a	n/a		
BCDL	10.0	Code	FBC2023/TPI2014	Matrix-MS							Weight: 101 lb	FT = 20%

**LUMBER**  
TOP CHORD 2x4 SP No.2  
BOT CHORD 2x4 SP No.2  
WEBS 2x4 SP No.3 \*Except\* 8-2,6-4:2x6 SP No.2

**BRACING**  
TOP CHORD Structural wood sheathing directly applied, except end verticals.  
BOT CHORD Rigid ceiling directly applied or 8-11-0 oc bracing.

**REACTIONS** (size) 6=0-3-0, 8=0-3-0  
Max Horiz 8=345 (LC 11)  
Max Uplift 6=-119 (LC 12), 8=-119 (LC 13)  
Max Grav 6=546 (LC 1), 8=546 (LC 1)

**FORCES** (lb) - Maximum Compression/Maximum Tension  
TOP CHORD 1-2=0/54, 2-3=-461/216, 3-4=-521/215, 4-5=0/54, 2-8=-527/236, 4-6=-511/277  
BOT CHORD 7-8=-414/415, 6-7=-111/154  
WEBS 3-7=-165/305, 2-7=0/205, 4-7=-181/331

**NOTES**

- 1) Unbalanced roof live loads have been considered for this design.
- 2) Designed to ASCE 7-22 basic load combinations for allowable stress design unless otherwise noted.
- 3) Wind: ASCE 7-22; Vult=130mph (3-second gust) Vasd=101mph; TCDL=4.2psf; BCDL=3.0psf; h=18ft; Cat. II; Exp B; Enclosed; MWFRS (envelope) exterior (2) zone and C-C Zone1 zone; end vertical left and right exposed;C-C for members and forces & MWFRS for reactions shown; Lumber DOL=1.60 plate grip DOL=1.60
- 4) Building Designer / Project engineer responsible for verifying applied roof live load shown covers rain loading requirements specific to the use of this truss component.
- 5) This truss has been designed for a 10.0 psf bottom chord live load nonconcurrent with any other live loads.

- 6) \* This truss has been designed for a live load of 20.0psf on the bottom chord in all areas where a rectangle 3-06-00 tall by 2-00-00 wide will fit between the bottom chord and any other members.
- 7) Bearing at joint(s) 6, 8 considers parallel to grain value using ANSI/TPI 1 angle to grain formula. Building designer should verify capacity of bearing surface.
- 8) Provide mechanical connection (by others) of truss to bearing plate at joint(s) 6.
- 9) Provide mechanical connection (by others) of truss to bearing plate capable of withstanding 119 lb uplift at joint 6 and 119 lb uplift at joint 8.

**LOAD CASE(S)** Standard

This item has been digitally signed and sealed by ORegan, Philip, PE on the date indicated here. Printed copies of this document are not considered signed and sealed and the signature must be verified on any electronic copies.

Philip J. O'Regan PE No.58126  
MiTek Inc. DBA MiTek USA FL Cert 63014  
16023 Swingley Ridge Rd. Chesterfield, MO 63017  
Date:

May 22,2026

**WARNING - Verify design parameters and READ NOTES ON THIS AND INCLUDED MITEK REFERENCE PAGE MII-7473 rev. 1/2/2023 BEFORE USE.**

Design valid for use only with MiTek® connectors. This design is based only upon parameters shown, and is for an individual building component, not a truss system. Before use, the building designer must verify the applicability of design parameters and properly incorporate this design into the overall building design. Bracing indicated is to prevent buckling of individual truss web and/or chord members only. Additional temporary and permanent bracing is always required for stability and to prevent collapse with possible personal injury and property damage. For general guidance regarding the fabrication, storage, delivery, erection and bracing of trusses and truss systems, see **ANSI/TPI1 Quality Criteria and DSB-22** available from Truss Plate Institute (www.tpinst.org) and **BCSI Building Component Safety Information** available from the Structural Building Component Association (www.sbcsccomponents.com)

**MiTek®**

16023 Swingley Ridge Rd.  
Chesterfield, MO 63017  
314.434.1200 / MiTek-US.com

Job 5449020	Truss T27G	Truss Type Scissor Supported Gable	Qty 1	Ply 1	Job Reference (optional) T41274328
----------------	---------------	---------------------------------------	----------	----------	---------------------------------------

Builders FirstSource (Lake City,FL), Lake City, FL - 32055,

Run: 25.40 S Apr 17 2026 Print: 25.4.0 S Apr 17 2026 MiTek Industries, Inc. Wed May 20 15:14:34

Page: 1

ID:3gberZhnKf0ycYtkjwR5hUzEbbG-RfC?PsB70Hq3NSgPqnL8w3uITXbGKwRcDoi7J4zJC?f

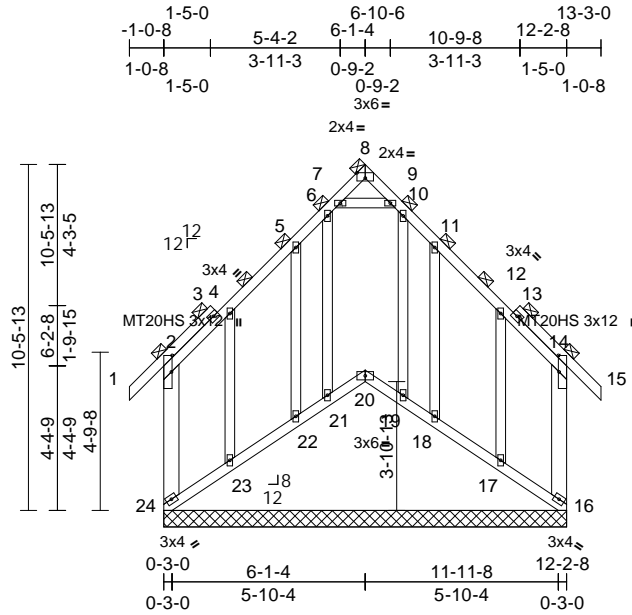

Scale = 1:69.8

Plate Offsets (X, Y): [2:0-6-0,0-0-4], [8:0-3-0,Edge], [10:0-0-0,Edge], [11:0-0-0,Edge], [12:0-0-0,Edge], [13:0-0-0,0-0-0], [14:0-6-0,0-0-4]

Loading	(psf)	Spacing	2-0-0	CSI	DEFL	in	(loc)	l/defl	L/d	PLATES	GRIP	
TCLL (roof)	20.0	Plate Grip DOL	1.25	TC	0.33	Vert(LL)	n/a	-	n/a	999	MT20	244/190
TCDL	10.0	Lumber DOL	1.25	BC	0.38	Vert(CT)	n/a	-	n/a	999	MT20HS	187/143
BCLL	0.0*	Rep Stress Incr	YES	WB	0.13	Horz(CT)	-0.01	16	n/a	n/a		
BCDL	10.0	Code	FBC2023/TPI2014	Matrix-MS								
											Weight: 129 lb	FT = 20%

**LUMBER**  
TOP CHORD 2x4 SP No.2  
BOT CHORD 2x4 SP No.2  
WEBS 2x6 SP No.2 \*Except\* 7-9:2x4 SP No.3  
OTHERS 2x4 SP No.3

**BRACING**  
TOP CHORD 2-0-0 oc purlins, except end verticals.  
BOT CHORD Rigid ceiling directly applied or 6-0-0 oc bracing, Except:  
9-7-8 oc bracing: 23-24  
10-0-0 oc bracing: 16-17.

**REACTIONS** (size)  
16=12-2-8, 17=12-2-8, 18=12-2-8,  
19=12-2-8, 20=12-2-8, 21=12-2-8,  
22=12-2-8, 23=12-2-8, 24=12-2-8  
Max Horiz 24=327 (LC 11)  
Max Uplift 16=-287 (LC 9), 17=-410 (LC 8),  
18=-91 (LC 13), 19=-22 (LC 10),  
20=-215 (LC 11), 21=-28 (LC 11),  
22=-91 (LC 12), 23=-415 (LC 9),  
24=-498 (LC 8)  
Max Grav 16=345 (LC 11), 17=507 (LC 11),  
18=136 (LC 19), 19=150 (LC 12),  
20=216 (LC 8), 21=150 (LC 13),  
22=137 (LC 20), 23=514 (LC 10),  
24=568 (LC 11)

**FORCES** (lb) - Maximum Compression/Maximum Tension  
TOP CHORD 2-24=-304/312, 1-2=0/49, 2-4=-255/261,  
4-5=-119/273, 5-6=-175/366, 6-7=-128/221,  
7-8=-63/5, 8-9=-63/5, 9-10=-128/221,  
10-11=-174/364, 11-12=-121/275,  
12-14=-250/256, 14-15=0/49, 14-16=-300/307  
BOT CHORD 23-24=-302/267, 22-23=-210/180,  
21-22=-237/204, 20-21=-220/191,  
19-20=-225/194, 18-19=-212/181,  
17-18=-248/212, 16-17=-146/143

**WEBS**  
6-21=-208/48, 10-19=-206/46, 4-23=-292/263,  
5-22=-126/131, 12-17=-288/259,  
11-18=-126/131, 7-9=-138/327

**NOTES**

- Unbalanced roof live loads have been considered for this design.
- Designed to ASCE 7-22 basic load combinations for allowable stress design unless otherwise noted.
- Wind: ASCE 7-22; Vult=130mph (3-second gust) Vasd=101mph; TC DL=4.2psf; BC DL=3.0psf; h=18ft; Cat. II; Exp B; Enclosed; MWFRS (envelope) exterior (2) zone and C-C Zone2 zone; end vertical left and right exposed; C-C for members and forces & MWFRS for reactions shown; Lumber DOL=1.60 plate grip DOL=1.60
- Truss designed for wind loads in the plane of the truss only. For studs exposed to wind (normal to the face), see Standard Industry Gable End Details as applicable, or consult qualified building designer as per ANSI/TPI 1.
- Building Designer / Project engineer responsible for verifying applied roof live load shown covers rain loading requirements specific to the use of this truss component.
- All plates are MT20 plates unless otherwise indicated.
- All plates are 2x4 (||) MT20 unless otherwise indicated.
- Gable requires continuous bottom chord bearing.
- Truss to be fully sheathed from one face or securely braced against lateral movement (i.e. diagonal web).
- Gable studs spaced at 2-0-0 oc.
- This truss has been designed for a 10.0 psf bottom chord live load nonconcurrent with any other live loads.
- \* This truss has been designed for a live load of 20.0psf on the bottom chord in all areas where a rectangle 3-06-00 tall by 2-00-00 wide will fit between the bottom chord and any other members.
- Provide mechanical connection (by others) of truss to bearing plate capable of withstanding 498 lb uplift at joint 24, 215 lb uplift at joint 20, 287 lb uplift at joint 16, 28 lb uplift at joint 21, 22 lb uplift at joint 19, 415 lb uplift at joint 23, 91 lb uplift at joint 22, 410 lb uplift at joint 17 and 91 lb uplift at joint 18.

- Beveled plate or shim required to provide full bearing surface with truss chord at joint(s) 20, 21, 19, 23, 22, 17, 18.
- Graphical purlin representation does not depict the size or the orientation of the purlin along the top and/or bottom chord.

**LOAD CASE(S)** Standard

This item has been digitally signed and sealed by O'Regan, Philip, PE on the date indicated here. Printed copies of this document are not considered signed and sealed and the signature must be verified on any electronic copies.

Philip J. O'Regan PE No.58126  
MiTek Inc. DBA MiTek USA FL Cert 6634  
16025 Swingley Ridge Rd. Chesterfield, MO 63017  
Date:

May 22, 2026

**WARNING - Verify design parameters and READ NOTES ON THIS AND INCLUDED MITEK REFERENCE PAGE MII-7473 rev. 1/2/2023 BEFORE USE.**

Design valid for use only with MiTek® connectors. This design is based only upon parameters shown, and is for an individual building component, not a truss system. Before use, the building designer must verify the applicability of the design parameters and properly incorporate this design into the overall building design. Bracing indicated is to prevent buckling of individual truss web and/or chord members only. Additional temporary and permanent bracing is always required for stability and to prevent collapse with possible personal injury and property damage. For general guidance regarding the fabrication, storage, delivery, erection and bracing of trusses and truss systems, see **ANSI/TPI1 Quality Criteria and DSB-22** available from Truss Plate Institute (www.tpinst.org) and **BCSI Building Component Safety Information** available from the Structural Building Component Association (www.sbcsccomponents.com)

**MiTek®**

16025 Swingley Ridge Rd.  
Chesterfield, MO 63017  
314.434.1200 / MiTek-US.com

Job 5449020	Truss T28	Truss Type Scissor	Qty 3	Ply 1	Job Reference (optional) T41274329
----------------	--------------	-----------------------	----------	----------	---------------------------------------

Builders FirstSource (Lake City,FL), Lake City, FL - 32055,

Run: 25.40 S Apr 17 2026 Print: 25.4.0 S Apr 17 2026 MiTek Industries, Inc. Wed May 20 15:14:35  
ID:uqzFS8ppOGy0ufnZTZrUwdzEcRL-RfC?PsB70Hq3NSgPqnL8w3ulTXbGKWrCDoi7J4zJC?f

Page: 1

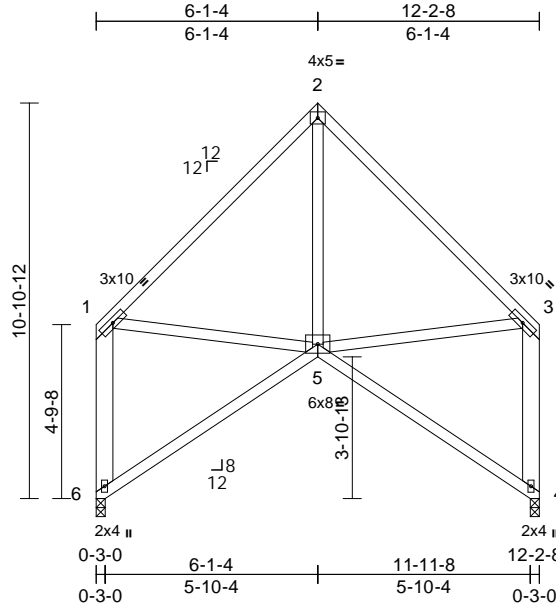

Scale = 1:63.5

Plate Offsets (X, Y): [3:0-0-0,0-0-0]

Loading	(psf)	Spacing	2-0-0	CSI	DEFL	in	(loc)	l/defl	L/d	PLATES	GRIP	
TCLL (roof)	20.0	Plate Grip DOL	1.25	TC	0.45	Vert(LL)	-0.04	5-6	>999	240	MT20	244/190
TCDL	10.0	Lumber DOL	1.25	BC	0.27	Vert(CT)	-0.09	5-6	>999	180		
BCLL	0.0*	Rep Stress Incr	YES	WB	0.09	Horz(CT)	0.02	4	n/a	n/a		
BCDL	10.0	Code	FBC2023/TPI2014	Matrix-MS							Weight: 96 lb	FT = 20%

**LUMBER**  
TOP CHORD 2x4 SP No.2  
BOT CHORD 2x4 SP No.2  
WEBS 2x4 SP No.3 \*Except\* 6-1,4-3:2x6 SP No.2

**BRACING**  
TOP CHORD Structural wood sheathing directly applied, except end verticals.  
BOT CHORD Rigid ceiling directly applied or 10-0-0 oc bracing.

**REACTIONS** (size) 4=0-3-0, 6=0-3-0  
Max Horiz 6=145 (LC 9)  
Max Uplift 4=-132 (LC 12), 6=-132 (LC 13)  
Max Grav 4=470 (LC 1), 6=470 (LC 1)

**FORCES** (lb) - Maximum Compression/Maximum Tension  
TOP CHORD 1-2=-451/126, 2-3=-474/179, 1-6=-431/153, 3-4=-431/155  
BOT CHORD 5-6=-201/240, 4-5=-41/93  
WEBS 2-5=-61/230, 1-5=-3/210, 3-5=-90/275

- 6) \* This truss has been designed for a live load of 20.0psf on the bottom chord in all areas where a rectangle 3-06-00 tall by 2-00-00 wide will fit between the bottom chord and any other members.
- 7) Bearing at joint(s) 4, 6 considers parallel to grain value using ANSI/TPI 1 angle to grain formula. Building designer should verify capacity of bearing surface.
- 8) Provide mechanical connection (by others) of truss to bearing plate capable of withstanding 132 lb uplift at joint 4 and 132 lb uplift at joint 6.

**LOAD CASE(S)** Standard

- NOTES**
- 1) Unbalanced roof live loads have been considered for this design.
  - 2) Designed to ASCE 7-22 basic load combinations for allowable stress design unless otherwise noted.
  - 3) Wind: ASCE 7-22; Vult=130mph (3-second gust) Vasd=101mph; TCDL=4.2psf; BCDL=3.0psf; h=18ft; Cat. II; Exp B; Enclosed; MWFRS (envelope) exterior (2) zone and C-C Zone1 zone;C-C for members and forces & MWFRS for reactions shown; Lumber DOL=1.60 plate grip DOL=1.60
  - 4) Building Designer / Project engineer responsible for verifying applied roof live load shown covers rain loading requirements specific to the use of this truss component.
  - 5) This truss has been designed for a 10.0 psf bottom chord live load nonconcurrent with any other live loads.

This item has been digitally signed and sealed by ORegan, Philip, PE on the date indicated here. Printed copies of this document are not considered signed and sealed and the signature must be verified on any electronic copies.

Philip J. O'Regan PE No.58126  
MiTek Inc. DBA MiTek USA FL Cert 63014  
16023 Swingley Ridge Rd. Chesterfield, MO 63017  
Date:

May 22,2026

<p><b>WARNING - Verify design parameters and READ NOTES ON THIS AND INCLUDED MITEK REFERENCE PAGE MII-7473 rev. 1/2/2023 BEFORE USE.</b></p> <p>Design valid for use only with MiTek® connectors. This design is based only upon parameters shown, and is for an individual building component, not a truss system. Before use, the building designer must verify the applicability of design parameters and properly incorporate this design into the overall building design. Bracing indicated is to prevent buckling of individual truss web and/or chord members only. Additional temporary and permanent bracing is always required for stability and to prevent collapse with possible personal injury and property damage. For general guidance regarding the fabrication, storage, delivery, erection and bracing of trusses and truss systems, see <b>ANSI/TPI1 Quality Criteria and DSB-22</b> available from Truss Plate Institute (www.tpinst.org) and <b>BCSI Building Component Safety Information</b> available from the Structural Building Component Association (www.sbcsccomponents.com)</p>	 <p>16023 Swingley Ridge Rd.  Chesterfield, MO 63017  314.434.1200 / MiTek-US.com</p>
------------------------------------------------------------------------------------------------------------------------------------------------------------------------------------------------------------------------------------------------------------------------------------------------------------------------------------------------------------------------------------------------------------------------------------------------------------------------------------------------------------------------------------------------------------------------------------------------------------------------------------------------------------------------------------------------------------------------------------------------------------------------------------------------------------------------------------------------------------------------------------------------------------------------------------------------------------------------------------------------------------------------------------------------------------------------------------------------------------------	------------------------------------------------------------------------------------------------------------------------------------------------------------------------------------

Job 5449020	Truss T29	Truss Type Common Girder	Qty 1	Ply 2	Job Reference (optional) T41274330
----------------	--------------	-----------------------------	----------	----------	---------------------------------------

Builders FirstSource (Lake City,FL), Lake City, FL - 32055,

Run: 25.40 S Apr 17 2026 Print: 25.4.0 S Apr 17 2026 MiTek Industries, Inc. Wed May 20 15:14:35  
ID:mjQRuostXmcd4IsHwGIU7zEbhW-RfC?PsB70Hq3NSgPqnL8w3uTXbGKWrCDoi7J4zJC?F

Page: 1

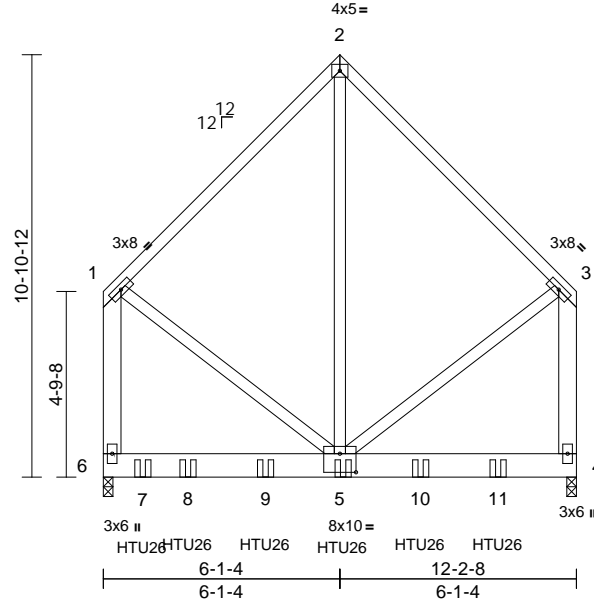

Scale = 1:59.4

Plate Offsets (X, Y): [3:0-0-0,0-0-0], [5:0-5-0,0-5-12]

Loading	(psf)	Spacing	2-0-0	CSI	DEFL	in	(loc)	l/defl	L/d	PLATES	GRIP	
TCLL (roof)	20.0	Plate Grip DOL	1.25	TC	0.32	Vert(LL)	-0.03	5-6	>999	240	MT20	244/190
TCDL	10.0	Lumber DOL	1.25	BC	0.23	Vert(CT)	-0.05	5-6	>999	180		
BCLL	0.0*	Rep Stress Incr	NO	WB	0.40	Horz(CT)	0.00	4	n/a	n/a		
BCDL	10.0	Code	FBC2023/TPI2014	Matrix-MS							Weight: 238 lb	FT = 20%

**LUMBER**  
TOP CHORD 2x4 SP No.2  
BOT CHORD 2x8 SP 2400F 2.0E  
WEBS 2x4 SP No.3 \*Except\* 6-1,4-3:2x6 SP No.2

**BRACING**  
TOP CHORD Structural wood sheathing directly applied, except end verticals.  
BOT CHORD Rigid ceiling directly applied or 10-0-0 oc bracing.

**REACTIONS** (size) 4=0-3-0, 6=0-3-0  
Max Horiz 6=145 (LC 5)  
Max Uplift 4=700 (LC 8), 6=877 (LC 9)  
Max Grav 4=2907 (LC 2), 6=3687 (LC 2)

**FORCES** (lb) - Maximum Compression/Maximum Tension  
TOP CHORD 1-2=-1703/469, 2-3=-1702/469, 1-6=-2074/532, 3-4=-2091/536  
BOT CHORD 5-6=-178/210, 4-5=-43/80  
WEBS 2-5=-465/2001, 1-5=-341/1338, 3-5=-348/1365

- NOTES**
- 2-ply truss to be connected together with 10d (0.131"x3") nails as follows:  
Top chords connected as follows: 2x4 - 1 row at 0-9-0 oc, 2x6 - 2 rows staggered at 0-9-0 oc.  
Bottom chords connected as follows: 2x8 - 2 rows staggered at 0-9-0 oc.  
Web connected as follows: 2x4 - 1 row at 0-9-0 oc.
  - All loads are considered equally applied to all plies, except if noted as front (F) or back (B) face in the LOAD CASE(S) section. Ply to ply connections have been provided to distribute only loads noted as (F) or (B), unless otherwise indicated.
  - Unbalanced roof live loads have been considered for this design.
  - Designed to ASCE 7-22 basic load combinations for allowable stress design unless otherwise noted.

- Wind: ASCE 7-22; Vult=130mph (3-second gust)  
Vasd=101mph; TC DL=4.2psf; BCDL=3.0psf; h=18ft; Cat. II; Exp B; Enclosed; MWFRS (envelope) exterior (2) zone; Lumber DOL=1.60 plate grip DOL=1.60
- Building Designer / Project engineer responsible for verifying applied roof live load shown covers rain loading requirements specific to the use of this truss component.
- This truss has been designed for a 10.0 psf bottom chord live load nonconcurrent with any other live loads.
- \* This truss has been designed for a live load of 20.0psf on the bottom chord in all areas where a rectangle 3-06-00 tall by 2-00-00 wide will fit between the bottom chord and any other members.
- Provide mechanical connection (by others) of truss to bearing plate at joint(s) 4.
- Provide mechanical connection (by others) of truss to bearing plate capable of withstanding 877 lb uplift at joint 6 and 700 lb uplift at joint 4.
- Use Simpson Strong-Tie HTU26 (20-16d Girder, 11-10dx1 1/2 Truss, Single Ply Girder) or equivalent spaced at 2-0-0 oc max. starting at 1-0-12 from the left end to 10-2-12 to connect truss(es) to back face of bottom chord.
- Fill all nail holes where hanger is in contact with lumber.

**LOAD CASE(S)** Standard

- Dead + Roof Live (balanced): Lumber Increase=1.25, Plate Increase=1.25  
Uniform Loads (lb/ft)  
Vert: 1-2=-60, 2-3=-60, 4-6=-20  
Concentrated Loads (lb)  
Vert: 5=-862 (B), 7=-864 (B), 8=-862 (B), 9=-862 (B), 10=-862 (B), 11=-862 (B)

This item has been digitally signed and sealed by O'Regan, Philip, PE on the date indicated here. Printed copies of this document are not considered signed and sealed and the signature must be verified on any electronic copies.

Philip J. O'Regan PE No.58126  
MiTek Inc. DBA MiTek USA FL Cert 6634  
16023 Swingley Ridge Rd. Chesterfield, MO 63017  
Date:

May 22, 2026

<p><b>WARNING - Verify design parameters and READ NOTES ON THIS AND INCLUDED MITEK REFERENCE PAGE MII-7473 rev. 1/2/2023 BEFORE USE.</b></p> <p>Design valid for use only with MiTek® connectors. This design is based only upon parameters shown, and is for an individual building component, not a truss system. Before use, the building designer must verify the applicability of design parameters and properly incorporate this design into the overall building design. Bracing indicated is to prevent buckling of individual truss web and/or chord members only. Additional temporary and permanent bracing is always required for stability and to prevent collapse with possible personal injury and property damage. For general guidance regarding the fabrication, storage, delivery, erection and bracing of trusses and truss systems, see <b>ANSI/TPI1 Quality Criteria and DSB-22</b> available from Truss Plate Institute (www.tpinst.org) and <b>BCSI Building Component Safety Information</b> available from the Structural Building Component Association (www.sbcsccomponents.com)</p>	 <p>16023 Swingley Ridge Rd.  Chesterfield, MO 63017  314.434.1200 / MiTek-US.com</p>
------------------------------------------------------------------------------------------------------------------------------------------------------------------------------------------------------------------------------------------------------------------------------------------------------------------------------------------------------------------------------------------------------------------------------------------------------------------------------------------------------------------------------------------------------------------------------------------------------------------------------------------------------------------------------------------------------------------------------------------------------------------------------------------------------------------------------------------------------------------------------------------------------------------------------------------------------------------------------------------------------------------------------------------------------------------------------------------------------------------	------------------------------------------------------------------------------------------------------------------------------------------------------------------------------------

Job 5449020	Truss TG01	Truss Type Flat Girder	Qty 1	Ply 1	Job Reference (optional) T41274331
----------------	---------------	---------------------------	----------	----------	---------------------------------------

Builders FirstSource (Lake City,FL), Lake City, FL - 32055,

Run: 25.40 S Apr 17 2026 Print: 25.4.0 S Apr 17 2026 MiTek Industries, Inc. Wed May 20 15:14:35  
ID:Wv1sNjzSsJ2H3yQfLC?u4izEbB5-RfC?PsB70Hq3NSgPqnL8w3u1TXbGKWrCDoi7J4zJC?f

Page: 1

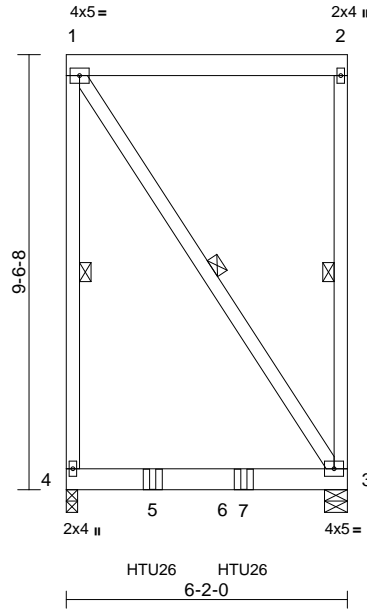

Scale = 1:50.5

Loading	(psf)	Spacing	2-0-0	CSI	DEFL	in	(loc)	l/defl	L/d	PLATES	GRIP
TCLL (roof)	20.0	Plate Grip DOL	1.25	TC	0.13	Vert(LL)	-0.12	3-4	>612	240	244/190
TCDL	10.0	Lumber DOL	1.25	BC	0.67	Vert(CT)	-0.21	3-4	>340	180	
BCLL	0.0*	Rep Stress Incr	NO	WB	0.00	Horz(CT)	0.00	3	n/a	n/a	
BCDL	10.0	Code	FBC2023/TPI2014	Matrix-MP							
										Weight: 70 lb	FT = 20%

**LUMBER**

TOP CHORD 2x6 SP 2400F 2.0E or 2x6 SP M 26  
BOT CHORD 2x6 SP 2400F 2.0E or 2x6 SP M 26  
WEBS 2x4 SP No.3

**BRACING**

TOP CHORD Structural wood sheathing directly applied, except end verticals.  
BOT CHORD Rigid ceiling directly applied or 9-5-0 oc bracing.  
WEBS 1 Row at midpt 1-4, 2-3, 1-3

**REACTIONS**

(size) 3=0-6-0, 4=0-3-0  
Max Uplift 3=-316 (LC 4), 4=-350 (LC 4)  
Max Grav 3=832 (LC 2), 4=928 (LC 2)

**FORCES**

(lb) - Maximum Compression/Maximum Tension  
TOP CHORD 1-4=-176/89, 1-2=0/0, 2-3=-176/89  
BOT CHORD 3-4=0/0  
WEBS 1-3=0/0

**NOTES**

- 1) Unbalanced roof live loads have been considered for this design.
- 2) Designed to ASCE 7-22 basic load combinations for allowable stress design unless otherwise noted.
- 3) Wind: ASCE 7-22; Vult=130mph (3-second gust)  
Vasd=101mph; TCDL=4.2psf; BCDL=3.0psf; h=18ft; Cat. II; Exp B; Enclosed; MWFRS (envelope) exterior (2) zone; Lumber DOL=1.60 plate grip DOL=1.60
- 4) Building Designer / Project engineer responsible for verifying applied roof live load shown covers rain loading requirements specific to the use of this truss component.
- 5) Provide adequate drainage to prevent water ponding.
- 6) This truss has been designed for a 10.0 psf bottom chord live load nonconcurrent with any other live loads.
- 7) \* This truss has been designed for a live load of 20.0psf on the bottom chord in all areas where a rectangle 3-06-00 tall by 2-00-00 wide will fit between the bottom chord and any other members, with BCDL = 10.0psf.

- 8) Provide mechanical connection (by others) of truss to bearing plate capable of withstanding 350 lb uplift at joint 4 and 316 lb uplift at joint 3.
- 9) Use Simpson Strong-Tie HTU26 (20-16d Girder, 11-10dx1 1/2 Truss, Single Ply Girder) or equivalent spaced at 2-0-0 oc max. starting at 1-10-12 from the left end to 3-10-12 to connect truss(es) to back face of bottom chord.
- 10) Fill all nail holes where hanger is in contact with lumber.
- 11) In the LOAD CASE(S) section, loads applied to the face of the truss are noted as front (F) or back (B).

**LOAD CASE(S)** Standard

- 1) Dead + Roof Live (balanced): Lumber Increase=1.25, Plate Increase=1.25  
Uniform Loads (lb/ft)  
Vert: 1-2=-60, 3-4=-20  
Concentrated Loads (lb)  
Vert: 5=-557 (B), 7=-557 (B)

This item has been digitally signed and sealed by ORegan, Philip, PE on the date indicated here. Printed copies of this document are not considered signed and sealed and the signature must be verified on any electronic copies.

Philip J. O'Regan PE No.58126  
MiTek Inc. DBA MiTek USA FL Cert 6634  
16023 Swingley Ridge Rd. Chesterfield, MO 63017  
Date:

May 22, 2026

**WARNING - Verify design parameters and READ NOTES ON THIS AND INCLUDED MITEK REFERENCE PAGE MII-7473 rev. 1/2/2023 BEFORE USE.**

Design valid for use only with MiTek® connectors. This design is based only upon parameters shown, and is for an individual building component, not a truss system. Before use, the building designer must verify the applicability of design parameters and properly incorporate this design into the overall building design. Bracing indicated is to prevent buckling of individual truss web and/or chord members only. Additional temporary and permanent bracing is always required for stability and to prevent collapse with possible personal injury and property damage. For general guidance regarding the fabrication, storage, delivery, erection and bracing of trusses and truss systems, see **ANSI/TPI1 Quality Criteria and DSB-22** available from Truss Plate Institute (www.tpinst.org) and **BCSI Building Component Safety Information** available from the Structural Building Component Association (www.sbcsccomponents.com)

**MiTek®**

16023 Swingley Ridge Rd.  
Chesterfield, MO 63017  
314.434.1200 / MiTek-US.com

Job 5449020	Truss TG02	Truss Type Flat Girder	Qty 1	Ply 2	Job Reference (optional) T41274332
----------------	---------------	---------------------------	----------	----------	---------------------------------------

Builders FirstSource (Lake City,FL), Lake City, FL - 32055,

Run: 25.40 S Apr 17 2026 Print: 25.4.0 S Apr 17 2026 MiTek Industries, Inc. Wed May 20 15:14:35  
ID:vz5vzwHq?7SZkkEAVTT71wzEbm7-RfC?PsB70Hq3NSgPqnL8w3ulTXbGKWrCDoi7J4zJC?ft

Page: 1

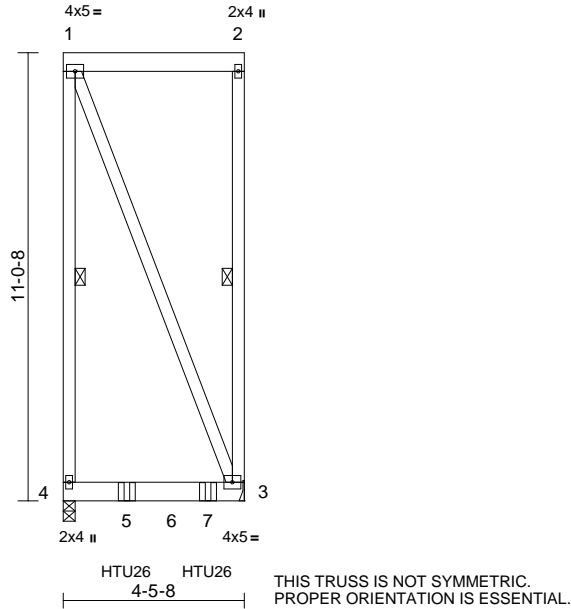

Scale = 1:56.8

Loading	(psf)	Spacing	2-0-0	CSI	DEFL	in	(loc)	l/defl	L/d	PLATES	GRIP	
TCLL (roof)	20.0	Plate Grip DOL	1.25	TC	0.07	Vert(LL)	0.02	3-4	>999	240	MT20	244/190
TCDL	10.0	Lumber DOL	1.25	BC	0.26	Vert(CT)	-0.02	3-4	>999	180		
BCLL	0.0*	Rep Stress Incr	NO	WB	0.00	Horz(CT)	0.00	3	n/a	n/a		
BCDL	10.0	Code	FBC2023/TPI2014	Matrix-MP							Weight: 134 lb	FT = 20%

#### LUMBER

TOP CHORD 2x6 SP No.2  
BOT CHORD 2x6 SP No.2  
WEBS 2x4 SP No.3

#### BRACING

TOP CHORD Structural wood sheathing directly applied, except end verticals.  
BOT CHORD Rigid ceiling directly applied or 10-0-0 oc bracing.  
WEBS 1 Row at midpt 1-4, 2-3

#### REACTIONS

(size) 3= Mechanical, 4=0-3-8  
Max Uplift 3=-394 (LC 4), 4=-298 (LC 4)  
Max Grav 3=651 (LC 15), 4=517 (LC 15)

#### FORCES

(lb) - Maximum Compression/Maximum Tension  
TOP CHORD 1-4=-125/63, 1-2=0/0, 2-3=-125/63  
BOT CHORD 3-4=0/0  
WEBS 1-3=0/0

#### NOTES

- 2-ply truss to be connected together with 10d (0.131"x3") nails as follows:  
Top chords connected as follows: 2x4 - 1 row at 0-9-0 oc, 2x6 - 2 rows staggered at 0-9-0 oc.  
Bottom chords connected as follows: 2x6 - 2 rows staggered at 0-9-0 oc.  
Web connected as follows: 2x4 - 1 row at 0-9-0 oc.
- All loads are considered equally applied to all plies, except if noted as front (F) or back (B) face in the LOAD CASE(S) section. Ply to ply connections have been provided to distribute only loads noted as (F) or (B), unless otherwise indicated.
- Unbalanced roof live loads have been considered for this design.
- Designed to ASCE 7-22 basic load combinations for allowable stress design unless otherwise noted.
- Wind: ASCE 7-22; Vult=130mph (3-second gust)  
Vasd=101mph; TCDL=4.2psf; BCDL=3.0psf; h=18ft; Cat. II; Exp B; Enclosed; MWFRS (envelope) exterior (2) zone; Lumber DOL=1.60 plate grip DOL=1.60

- Building Designer / Project engineer responsible for verifying applied roof live load shown covers rain loading requirements specific to the use of this truss component.
- Provide adequate drainage to prevent water ponding.
- This truss has been designed for a 10.0 psf bottom chord live load nonconcurrent with any other live loads.
- \* This truss has been designed for a live load of 20.0psf on the bottom chord in all areas where a rectangle 3-06-00 tall by 2-00-00 wide will fit between the bottom chord and any other members, with BCDL = 10.0psf.
- Refer to girder(s) for truss to truss connections.
- Provide mechanical connection (by others) of truss to bearing plate capable of withstanding 298 lb uplift at joint 4 and 394 lb uplift at joint 3.
- Use Simpson Strong-Tie HTU26 (20-16d Girder, 11-10dx1 1/2 Truss, Single Ply Girder) or equivalent spaced at 2-0-0 oc max. starting at 1-6-13 from the left end to 3-6-13 to connect truss(es) to back face of bottom chord.
- Fill all nail holes where hanger is in contact with lumber.

#### LOAD CASE(S) Standard

- Dead + Roof Live (balanced): Lumber Increase=1.25, Plate Increase=1.25  
Uniform Loads (lb/ft)  
Vert: 1-2=-60, 3-4=-20  
Concentrated Loads (lb)  
Vert: 5=-293 (B), 7=-296 (B)

This item has been digitally signed and sealed by O'Regan, Philip, PE on the date indicated here. Printed copies of this document are not considered signed and sealed and the signature must be verified on any electronic copies.

Philip J. O'Regan PE No.58126  
MiTek Inc. DBA MiTek USA FL Cert 6634  
16023 Swingley Ridge Rd. Chesterfield, MO 63017  
Date:

May 22, 2026

#### WARNING - Verify design parameters and READ NOTES ON THIS AND INCLUDED MITEK REFERENCE PAGE MII-7473 rev. 1/2/2023 BEFORE USE.

Design valid for use only with MiTek® connectors. This design is based only upon parameters shown, and is for an individual building component, not a truss system. Before use, the building designer must verify the applicability of design parameters and properly incorporate this design into the overall building design. Bracing indicated is to prevent buckling of individual truss web and/or chord members only. Additional temporary and permanent bracing is always required for stability and to prevent collapse with possible personal injury and property damage. For general guidance regarding the fabrication, storage, delivery, erection and bracing of trusses and truss systems, see **ANSI/TPI1 Quality Criteria and DSB-22** available from Truss Plate Institute (www.tpinst.org) and **BCSI Building Component Safety Information** available from the Structural Building Component Association (www.sbcsccomponents.com)

**MiTek®**

16023 Swingley Ridge Rd.  
Chesterfield, MO 63017  
314.434.1200 / MiTek-US.com

# Symbols

## PLATE LOCATION AND ORIENTATION

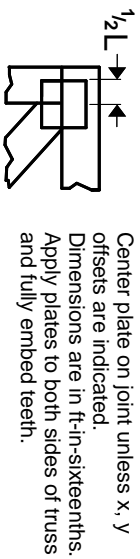

Center plate on joint unless x, y offsets are indicated. Dimensions are in ft-in-sixteenths. Apply plates to both sides of truss and fully embed teeth.

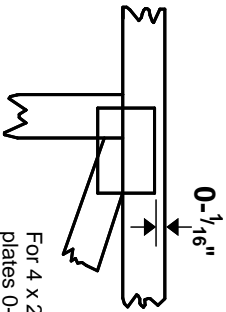

For 4 x 2 orientation, locate plates 0- 1/16" from outside edge of truss.



This symbol indicates the required direction of slots in connector plates.

\* Plate location details available in MITtek software or upon request.

## PLATE SIZE

4 X 4

The first dimension is the plate width measured perpendicular to slots. Second dimension is the length parallel to slots.

## LATERAL BRACING LOCATION



Indicated by symbol shown and/or by text in the bracing section of the output. Use T or I bracing if indicated.

## BEARING

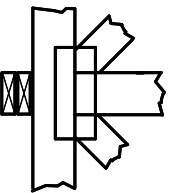

Indicates location where bearings (supports) occur. Icons vary but reaction section indicates joint number/letter where bearings occur. Min size shown is for crushing only.

## Industry Standards:

ANSI/TFP1: National Design Specification for Metal Plate Connected Wood Truss Construction.  
DSB-22: Design Standard for Bracing.  
BCSI: Building Component Safety Information, Guide to Good Practice for Handling, Installing, Restraining & Bracing of Metal Plate Connected Wood Trusses.

# Numbering System

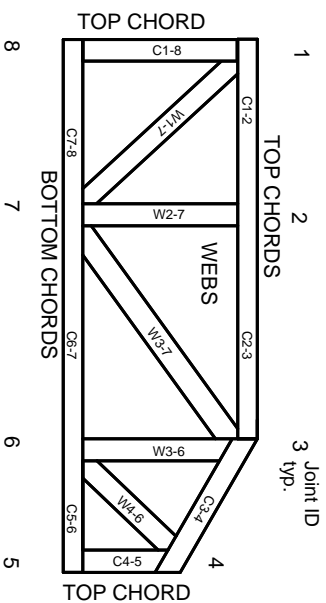

JOINTS ARE GENERALLY NUMBERED/LETTERED CLOCKWISE AROUND THE TRUSS STARTING AT THE JOINT FARTHEST TO THE LEFT.

CHORDS AND WEBS ARE IDENTIFIED BY END JOINT NUMBERS/LETTERS.

# Product Code Approvals

ICC-ES Reports:

ESR-1-1988, ESR-2362, ESR-2685, ESR-3282  
ESR-4722, ESL-1388

# Design General Notes

Trusses are designed for wind loads in the plane of the truss unless otherwise shown.

Lumber design values are in accordance with ANSI/TFP 1 section 6.3. These truss designs rely on Lumber values established by others.

© 2023 MITtek® All Rights Reserved

# General Safety Notes

## Failure to Follow Could Cause Property Damage or Personal Injury

1. Additional stability/bracing for truss system, e.g. diagonal or X-bracing, is always required. See BCSI.
2. Truss bracing must be designed by an engineer. For wide truss spacing, individual lateral braces themselves may require bracing, or alternative Tor I bracing should be considered.
3. Never exceed the design loading shown and never stack materials on inadequately braced trusses.
4. Provide copies of this truss design to the building designer, erection supervisor, property owner and all other interested parties.
5. Cut members to bear tightly against each other.
6. Place plates on each face of truss at each joint and embed fully. Knots and wane at joint locations are regulated by ANSI/TFP 1.
7. Design assumes trusses will be suitably protected from the environment in accord with ANSI/TFP 1.
8. Unless otherwise noted, moisture content of lumber shall not exceed 19% at time of fabrication.
9. Unless expressly noted, this design is not applicable for use with fire retardant, preservative treated, or green lumber.
10. Camber is a non-structural consideration and is the responsibility of truss fabricator. General practice is to camber for dead load deflection.
11. Plate type, size, orientation and location dimensions indicated are minimum plating requirements.
12. Lumber used shall be of the species and size, and in all respects, equal to or better than that specified.
13. Top chords must be sheathed or purlins provided at spacing indicated on design.
14. Bottom chords require lateral bracing at 10 ft. spacing, or less, if no ceiling is installed, unless otherwise noted.
15. Connections not shown are the responsibility of others.
16. Do not cut or alter truss member or plate without prior approval of an engineer.
17. Install and load vertically unless indicated otherwise.
18. Use of green or treated lumber may pose unacceptable environmental, health or performance risks. Consult with project engineer before use.
19. Review all portions of this design (front, back, words and pictures) before use. Reviewing pictures alone is not sufficient.
20. Design assumes manufacture in accordance with ANSI/TFP 1 Quality Criteria.
21. The design does not take into account any dynamic or other loads other than those expressly stated.

# MITek®

MITtek Engineering Reference Sheet: Mill-7473 rev. 1/2/2023