

BUILDING CHARACTERISTICS		CONSTRUCTION	
ELEMENT	CD		
Exterior Wall	19	COMMON BRK	100
Roof Structur	08	IRREGULAR	100
Roof Cover	03	COMP SHNGL	100
Interior Wall	05	DRYWALL	100
Interior Floo	12	HARDWOOD	80
Interior Floo	14	CARPET	20
Air Condition	03	CENTRAL	100
Heating Type	04	AIR DUCTED	100
Bedrooms		4	100
Bathrooms		3.5	100
Frame	02	WOOD FRAME	100
Stories	1.5	1.5	100
Architectual	05	CONV	100
Units		0	100
Condition Adj	03	03	100
Kitchen Adjus	01	01	100
Quality	09	09	
DOR CODE	0100	SINGLE FAMILY	
MAP NUM		MKT AREA	06
NEIGHBORHOOD/LOC	23316.010	1.00/	
AREA TYPE	TOTAL GROSS AREA	PCT OF BASE	YEAR
BAS	2,464	100	
FGR	552	55	
FOP	18	30	
FOP	100	30	
FSP	264	40	
FUS	880	100	
TOTALS	4,278		

MARKET ADJUSTMENTS											
TYPE	MDL	EFF. AREA	TOT ADJ PTS	EFF. BASE RATE	REPL. COST NEW	AYB	EYB	ECON	FNCT	NORM	% COND
1	SINGLE FAM	0%	- 2022								
Heated Area: 3344						HX Base Yr					

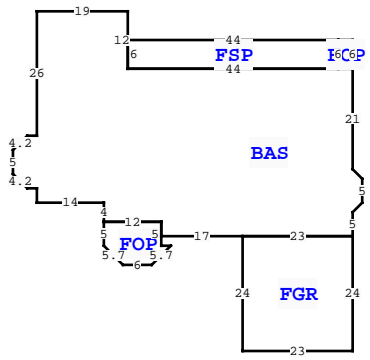
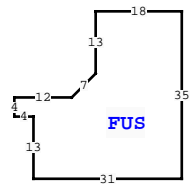

COLUMBIA COUNTY PROPERTY		PAGE 1 of 1	2
VALUATION SUMMARY			
VALUATION BY		STANDARD	
Tax Group: 2	Tax Dist:		
BUILDING MARKET VALUE		514,275	
TOTAL MARKET OB/XF VALUE		33,474	
TOTAL LAND VALUE - MARKET		38,500	
TOTAL MARKET VALUE		586,249	
SOH/AGL Deduction		0	
ASSESSED VALUE		586,249	
TOTAL EXEMPTION VALUE		0	
BASE TAXABLE VALUE		586,249	
TOTAL JUST VALUE		586,249	
NCON VALUE		0	
INCOME VALUE		0	
PREVIOUS YEAR MKT VALUE		593,915	

PERMIT NUM	DESCRIPTION	AMT	ISSUED
000050232	Roof Replacement	20,910	06/27/2024
25489	POOL ENCL	0	02/05/2007
21011	POOL	100	08/25/2003
17860	SFR	525	01/24/2001

SALES DATA						
OFF RECORD Number	DATE	TYPE INST	Q / U	V / I	RSN CD	SALE PRICE
1442/1147	7/01/2021	WD Q	Q	I	01	530,000
GRANTOR: EICHMAN BRUCE W & PAT						
GRANTEE: BESSONOFF PETER						
1062/0970	10/18/2005	WD Q	Q	I		434,000
GRANTOR: GUILMETTE						
GRANTEE: BRUCE AND PATSY EIC						

EXTRA FEATURES		225 NW SCENIC LAKE DR, LAKE CITY	
L N	OB/XF CODE	DESCRIPTION	BLD CAP
1	0166	CONC, PAVMT	0 0 0 0
2	0180	FPLC 1STRY	0 0 0 0
3	0280	POOL R/CON	0 0 0 0
4	0282	POOL ENCL	0 0 32 45
5	0120	CLFENCE 4	0 0 0 0
6	0060	CARPORT F	0 0 18 40
7	0294	SHED WOOD/	0 0 0 0

L N	OB/XF CODE	DESCRIPTION	BLD CAP	L	W	UNITS	UT	Adj R	ADJ UNIT PRICE	ORIG COND	YEAR ON	YEAR ACTUAL	Q	% COND	OB/XF MKT VALUE	NOTES
1	0166	CONC, PAVMT	0	0	0	2,430.00	UT	2.00	2.00	100	2001	2001	3	100	4,860	
2	0180	FPLC 1STRY	0	0	0	1.00	UT	2,000.00	2,000.00	100	2001	2001	3	100	2,000	
3	0280	POOL R/CON	0	0	0	428.00	UT	70.00	70.00	100	2003	2003	3	40	11,984	
4	0282	POOL ENCL	0	0	32	1,440.00	UT	15.00	15.00	100	2003	2003	3	40	8,640	
5	0120	CLFENCE 4	0	0	0	580.00	UT	6.50	6.50	100	2009	2009	3	100	3,770	
6	0060	CARPORT F	0	0	18	720.00	UT	4.50	4.50	50	2009	2009	3	50	1,620	
7	0294	SHED WOOD/	0	0	0	1.00	UT	0.00	0.00	100	2009	2009	3	100	600	
TOTAL OB/XF 33,474																

BUILDING NOTES	

BUILDING DIMENSIONS	
BAS= W19 S26 W2 L3 D3 S5 D3 R3 E2 S3 E14 S4 FOP= S5 D4 R4 E6 R4 U4 W2 N5 W12\$ E12 S3 E17 FGR= S24 E23 N24 W23\$ E23 N5 R2 U2 N5 U2 L2 N21 FOP= N6 W3 S6 E3\$ W3 FSP= N6 W44 S6 E44\$ W44 N12\$ PTR= N30 FUS= N35 W18 S13 D5 L5 W12 S4 E4 S13 E31\$ S30\$.	

LAND DESCRIPTION		TOTAL OB/XF 33,474																						
L N	USE CODE	CLS	LAND USE DESCRIPTION	CAP	R D	LOC ZONE	FRONT	DEPTH	TOT LND UTS	UNIT TYPE	D T	DPH FACT	% COND	TOT ADJ	UNIT PRICE	ADJ UNIT PRICE	LAND VALUE	OTHER ADJUSTMENTS AND NOTES	YEAR	DENSITY	DECL	FRZ	YR	CONSRV
1	0100	C	SFR	0		A-1	0.00	0.00	1.00	LT		1.00	1.00	1.10	35,000.00	38,500.00	38,500							