



Lumber design values are in accordance with ANSI/TPI 1 section 6.3  
These truss designs rely on lumber values established by others.

RE: 5152938 - THIERY RES.

MiTek, Inc.  
16023 Swingley Ridge Rd.  
Chesterfield, MO 63017  
314.434.1200

**Site Information:**

Customer Info: STEVE AYOUB CONST Project Name: Thiery Res. Model: Custom  
Lot/Block: N/A Subdivision: N/A  
Address: TBD, TBD  
City: Alachua Cty State: FL

**Name Address and License # of Structural Engineer of Record, If there is one, for the building.**

Name: License #:  
Address:  
City: State:

**General Truss Engineering Criteria & Design Loads (Individual Truss Design Drawings Show Special Loading Conditions):**

Design Code: FBC2023/TPI2014 Design Program: MiTek 20/20 8.8  
Wind Code: ASCE 7-22 Wind Speed: 130 mph  
Roof Load: 40.0 psf Floor Load: N/A psf

This package includes 29 individual, Truss Design Drawings and 0 Additional Drawings.  
With my seal affixed to this sheet, I hereby certify that I am the Truss Design Engineer and this index sheet conforms to 61G15-31.003, section 5 of the Florida Board of Professional Engineers Rules.

No.	Seal#	Truss Name	Date	No.	Seal#	Truss Name	Date
1	T39616957	CJ01	12/23/25	15	T39616971	T09	12/23/25
2	T39616958	CJ03	12/23/25	16	T39616972	T10	12/23/25
3	T39616959	CJ05	12/23/25	17	T39616973	T11	12/23/25
4	T39616960	EJ01	12/23/25	18	T39616974	T12	12/23/25
5	T39616961	HJ10	12/23/25	19	T39616975	T13	12/23/25
6	T39616962	T01	12/23/25	20	T39616976	T14	12/23/25
7	T39616963	T01G	12/23/25	21	T39616977	T15	12/23/25
8	T39616964	T02	12/23/25	22	T39616978	T16	12/23/25
9	T39616965	T03	12/23/25	23	T39616979	T17	12/23/25
10	T39616966	T04	12/23/25	24	T39616980	T18	12/23/25
11	T39616967	T05	12/23/25	25	T39616981	T19	12/23/25
12	T39616968	T06	12/23/25	26	T39616982	T20	12/23/25
13	T39616969	T07	12/23/25	27	T39616983	T21	12/23/25
14	T39616970	T08	12/23/25	28	T39616984	T21G	12/23/25

This item has been digitally signed and sealed by Velez, Joaquin, PE on the date adjacent to the seal.  
Printed copies of this document are not considered signed and sealed and the signature must be verified on any electronic copies

The truss drawing(s) referenced above have been prepared by  
MiTek USA, Inc. under my direct supervision based on the parameters  
provided by Builders FirstSource-Lake City, FL.

Truss Design Engineer's Name: Velez, Joaquin  
My license renewal date for the state of Florida is February 28, 2027.

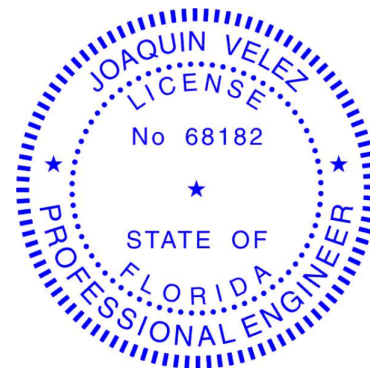

Joaquin Velez PE No.68182  
MiTek Inc. DBA MiTek USA FL Cert 6634  
16023 Swingley Ridge Rd. Chesterfield, MO 63017  
Date:

**IMPORTANT NOTE:** The seal on these truss component designs is a certification that the engineer named is licensed in the jurisdiction(s) identified and that the designs comply with ANSI/TPI 1. These designs are based upon parameters shown (e.g., loads, supports, dimensions, shapes and design codes), which were given to MiTek or TRENCO. Any project specific information included is for MiTek's or TRENCO's customers file reference purpose only, and was not taken into account in the preparation of these designs. MiTek or TRENCO has not independently verified the applicability of the design parameters or the designs for any particular building. Before use, the building designer should verify applicability of design parameters and properly incorporate these designs into the overall building design per ANSI/TPI 1, Chapter 2.

December 23,2025



---

RE: 5152938 - THIERY RES.

MiTek, Inc.  
16023 Swingley Ridge Rd.  
Chesterfield, MO 63017  
314.434.1200

**Site Information:**

Customer Info: STEVE AYOUB CONST    Project Name: Thiery Res.    Model: Custom  
Lot/Block: N/A    Subdivision: N/A  
Address: TBD, TBD  
City: Alachua Cty    State: FL

No.	Seal#	Truss Name	Date
29	T39616985	T22	12/23/25

Job 5152938	Truss CJ01	Truss Type Jack-Open	Qty 8	Ply 1	THIERY RES. T39616957
----------------	---------------	-------------------------	----------	----------	--------------------------

Builders FirstSource (Lake City,FL), Lake City, FL - 32055,

8.830 s Sep 3 2025 MiTek Industries, Inc. Mon Dec 22 07:34:51 2025 Page 1

ID:qPB6\_vd6KiSva2ixBwiw7Vy6Vgm-\_A6sP12FGnShT17BqpGROq71p37wbUNEHtK7XMy6U62



Scale = 1:9.5

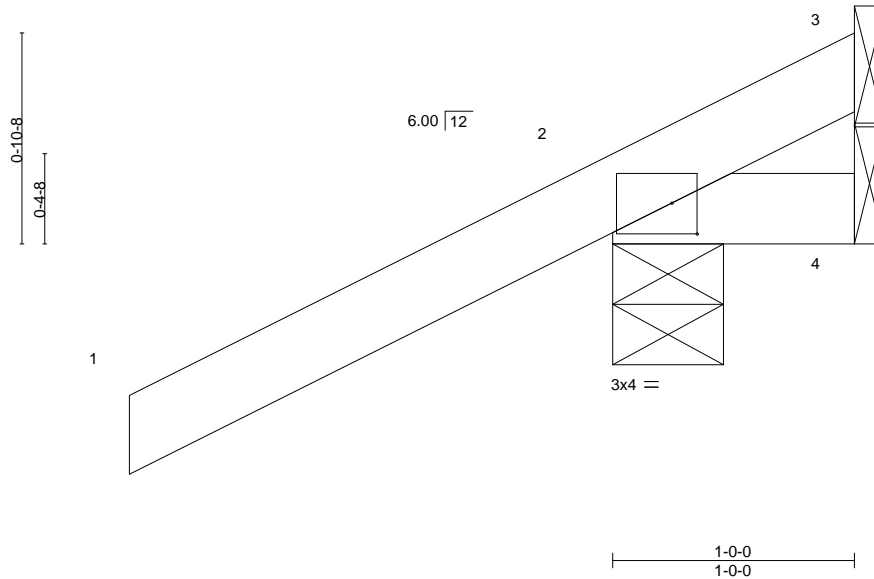

Plate Offsets (X,Y)--	[2:0-1-4,0-1-8]									
<b>LOADING</b> (psf)	<b>SPACING-</b>	2-0-0	<b>CSI.</b>	<b>DEFL.</b>	in (loc)	l/defl	L/d	<b>PLATES</b>	<b>GRIP</b>	
TCLL 20.0	Plate Grip DOL	1.25	TC 0.31	Vert(LL)	0.00	7	>999	240	MT20	244/190
TCDL 10.0	Lumber DOL	1.25	BC 0.07	Vert(CT)	0.00	7	>999	180		
BCLL 0.0 *	Rep Stress Incr	YES	WB 0.00	Horz(CT)	0.00	2	n/a	n/a		
BCDL 10.0	Code	FBC2023/TPI2014	Matrix-MP							
									Weight: 7 lb	FT = 20%

**LUMBER-**  
TOP CHORD 2x4 SP No.2  
BOT CHORD 2x4 SP No.2

**BRACING-**  
TOP CHORD Structural wood sheathing directly applied or 1-0-0 oc purlins.  
BOT CHORD Rigid ceiling directly applied or 10-0-0 oc bracing.

**REACTIONS.** (size) 3=Mechanical, 2=0-5-8, 4=Mechanical  
Max Horz 2=52(LC 12)  
Max Uplift 3=30(LC 1), 2=120(LC 12), 4=52(LC 1)  
Max Grav 3=15(LC 16), 2=281(LC 1), 4=32(LC 12)

**FORCES.** (lb) - Max. Comp./Max. Ten. - All forces 250 (lb) or less except when shown.

**NOTES-**

- 1) Wind: ASCE 7-22; Vult=130mph (3-second gust) Vasd=101mph; TC DL=4.2psf; BCDL=3.0psf; h=20ft; Cat. II; Exp B; Encl., GCpi=0.18; MWFRS (envelope) gable end zone and C-C Zone3 zone; porch left and right exposed;C-C for members and forces & MWFRS for reactions shown; Lumber DOL=1.60 plate grip DOL=1.60
- 2) Building Designer / Project engineer responsible for verifying applied roof live load shown covers rain loading requirements specific to the use of this truss component.
- 3) This truss has been designed for a 10.0 psf bottom chord live load nonconcurrent with any other live loads.
- 4) \* This truss has been designed for a live load of 20.0psf on the bottom chord in all areas where a rectangle 3-6-0 tall by 2-0-0 wide will fit between the bottom chord and any other members.
- 5) Refer to girder(s) for truss to truss connections.
- 6) Provide mechanical connection (by others) of truss to bearing plate capable of withstanding 100 lb uplift at joint(s) 3, 4 except (jt=lb) 2=120.

This item has been digitally signed and sealed by Velez, Joaquin, PE on the date indicated here. Printed copies of this document are not considered signed and sealed and the signature must be verified on any electronic copies.

Joaquin Velez PE No.68182  
MiTek Inc. DBA MiTek USA FL Cert 6634  
16023 Swingley Ridge Rd.  
Chesterfield, MO 63017

Date:  
December 23,2025

**WARNING - Verify design parameters and READ NOTES ON THIS AND INCLUDED MITEK REFERENCE PAGE MII-7473 rev. 1/2/2023 BEFORE USE.**

Design valid for use only with MiTek® connectors. This design is based only upon parameters shown, and is for an individual building component, not a truss system. Before use, the building designer must verify the applicability of design parameters and properly incorporate this design into the overall building design. Bracing indicated is to prevent buckling of individual truss web and/or chord members only. Additional temporary and permanent bracing is always required for stability and to prevent collapse with possible personal injury and property damage. For general guidance regarding the fabrication, storage, delivery, erection and bracing of trusses and truss systems, see **ANSI/TPI1 Quality Criteria and DSB-22** available from Truss Plate Institute (www.tpinst.org) and **BCSI Building Component Safety Information** available from the Structural Building Component Association (www.sbcsccomponents.com)

**MiTek®**

16023 Swingley Ridge Rd.  
Chesterfield, MO 63017  
314.434.1200 / MiTek-US.com

Job 5152938	Truss CJ03	Truss Type Jack-Open	Qty 8	Ply 1	THIERY RES. T39616958
----------------	---------------	-------------------------	----------	----------	--------------------------

Builders FirstSource (Lake City,FL), Lake City, FL - 32055, 8.830 s Sep 3 2025 MiTek Industries, Inc. Mon Dec 22 07:34:52 2025 Page 1  
 ID:qPB6\_vd6KiSva2ixBwiw7Vy6Vgm-SNgEcN3t14aY4SINNXogx1gCZSSAKxcNWX4h3py6U61

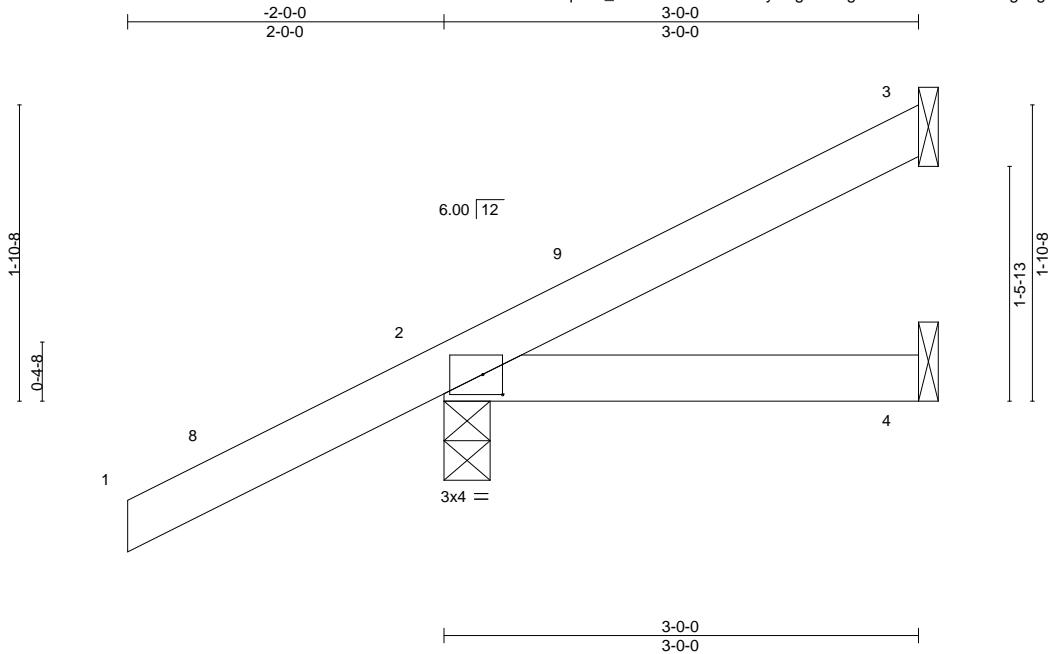

Scale = 1:14.6

Plate Offsets (X,Y)--	[2:0-1-8,0-1-9]				
<b>LOADING</b> (psf)	<b>SPACING-</b> 2-0-0	<b>CSI.</b>	<b>DEFL.</b> in (loc) l/defl L/d	<b>PLATES</b>	<b>GRIP</b>
TCLL 20.0	Plate Grip DOL 1.25	TC 0.31	Vert(LL) -0.00 4-7 >999 240	MT20	244/190
TCDL 10.0	Lumber DOL 1.25	BC 0.07	Vert(CT) -0.00 4-7 >999 180		
BCLL 0.0 *	Rep Stress Incr YES	WB 0.00	Horz(CT) 0.00 2 n/a n/a		
BCDL 10.0	Code FBC2023/TPI2014	Matrix-MP		Weight: 13 lb	FT = 20%

**LUMBER-**  
 TOP CHORD 2x4 SP No.2  
 BOT CHORD 2x4 SP No.2

**BRACING-**  
 TOP CHORD Structural wood sheathing directly applied or 3-0-0 oc purlins.  
 BOT CHORD Rigid ceiling directly applied or 10-0-0 oc bracing.

**REACTIONS.** (size) 3=Mechanical, 2=0-3-8, 4=Mechanical  
 Max Horz 2=90(LC 12)  
 Max Uplift 3=36(LC 12), 2=91(LC 12), 4=16(LC 9)  
 Max Grav 3=57(LC 1), 2=278(LC 1), 4=47(LC 3)

**FORCES.** (lb) - Max. Comp./Max. Ten. - All forces 250 (lb) or less except when shown.

**NOTES-**

- 1) Wind: ASCE 7-22; Vult=130mph (3-second gust) Vasd=101mph; TCDL=4.2psf; BCDL=3.0psf; h=20ft; Cat. II; Exp B; Encl., GCpi=0.18; MWFRS (envelope) gable end zone and C-C Zone3 -2-0-0 to 1-0-0, Zone1 1-0-0 to 2-1-1-4 zone; porch left and right exposed; C-C for members and forces & MWFRS for reactions shown; Lumber DOL=1.60 plate grip DOL=1.60
- 2) Building Designer / Project engineer responsible for verifying applied roof live load shown covers rain loading requirements specific to the use of this truss component.
- 3) This truss has been designed for a 10.0 psf bottom chord live load nonconcurrent with any other live loads.
- 4) \* This truss has been designed for a live load of 20.0psf on the bottom chord in all areas where a rectangle 3-6-0 tall by 2-0-0 wide will fit between the bottom chord and any other members.
- 5) Refer to girder(s) for truss to truss connections.
- 6) Provide mechanical connection (by others) of truss to bearing plate capable of withstanding 100 lb uplift at joint(s) 3, 2, 4.

This item has been digitally signed and sealed by Velez, Joaquin, PE on the date indicated here. Printed copies of this document are not considered signed and sealed and the signature must be verified on any electronic copies.

Joaquin Velez PE No.68182  
 MiTek Inc. DBA MiTek USA FL Cert 6634  
 16023 Swingley Ridge Rd.  
 Chesterfield, MO 63017

Date:  
 December 23, 2025

**WARNING - Verify design parameters and READ NOTES ON THIS AND INCLUDED MITEK REFERENCE PAGE MII-7473 rev. 1/2/2023 BEFORE USE.**

Design valid for use only with MiTek® connectors. This design is based only upon parameters shown, and is for an individual building component, not a truss system. Before use, the building designer must verify the applicability of design parameters and properly incorporate this design into the overall building design. Bracing indicated is to prevent buckling of individual truss web and/or chord members only. Additional temporary and permanent bracing is always required for stability and to prevent collapse with possible personal injury and property damage. For general guidance regarding the fabrication, storage, delivery, erection and bracing of trusses and truss systems, see **ANSI/TPI1 Quality Criteria and DSB-22** available from Truss Plate Institute (www.tpinst.org) and **BCSI Building Component Safety Information** available from the Structural Building Component Association (www.sbcsccomponents.com)

**MiTek®**

16023 Swingley Ridge Rd.  
 Chesterfield, MO 63017  
 314.434.1200 / MiTek-US.com



Job 5152938	Truss EJ01	Truss Type Jack-Partial	Qty 29	Ply 1	THIERY RES. Job Reference (optional)	T39616960
----------------	---------------	----------------------------	-----------	----------	---	-----------

Builders FirstSource (Lake City,FL),

Lake City, FL - 32055,

8.830 s Sep 3 2025 MiTek Industries, Inc. Mon Dec 22 07:34:52 2025 Page 1

ID:qPB6\_vd6KiSva2ixBwiw7Vy6Vgm-SNgEcN3t14aY4SiNNXogx1g61SL2KxcNWX4h3py6U61

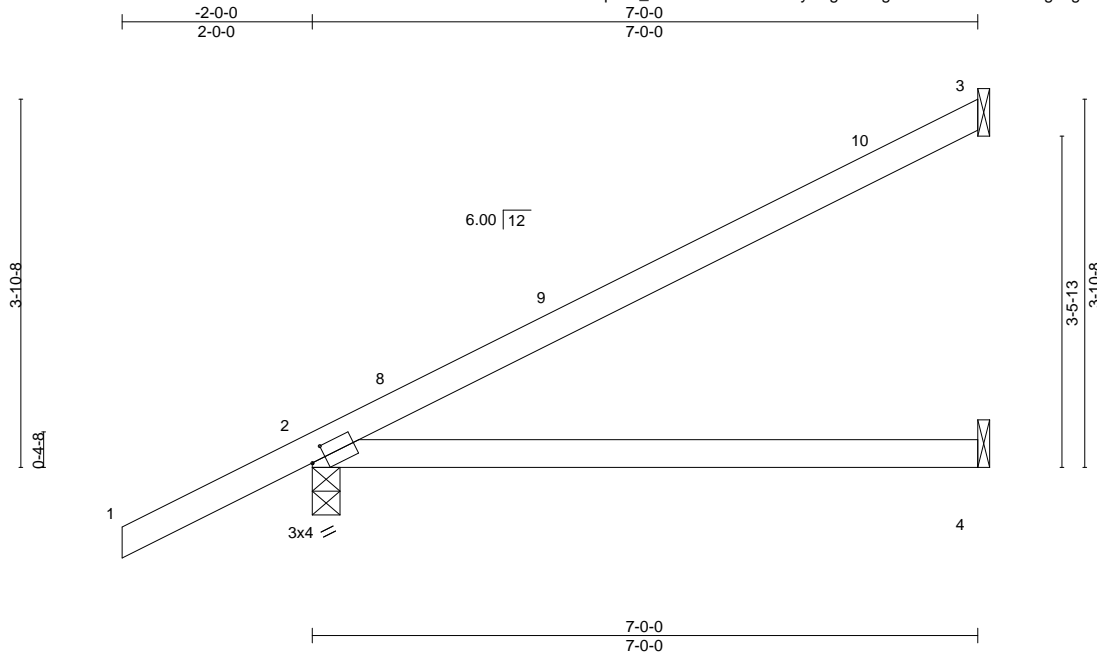

Scale: 1/2"=1'

Plate Offsets (X,Y)--	[2:0-1-13,0-1-8]							
<b>LOADING</b> (psf)	<b>SPACING-</b>	<b>CSI.</b>	<b>DEFL.</b>	in (loc)	l/defl	L/d	<b>PLATES</b>	<b>GRIP</b>
TCLL 20.0	2-0-0	TC 0.66	Vert(LL) 0.18	4-7	>474	240	MT20	244/190
TCDL 10.0	Plate Grip DOL 1.25	BC 0.52	Vert(CT) -0.22	4-7	>374	180		
BCLL 0.0 *	Lumber DOL 1.25	WB 0.00	Horz(CT) 0.01	2	n/a	n/a		
BCDL 10.0	Rep Stress Incr YES	Matrix-MS					Weight: 26 lb	FT = 20%
	Code FBC2023/TPI2014							

**LUMBER-**  
TOP CHORD 2x4 SP No.2  
BOT CHORD 2x4 SP No.2

**BRACING-**  
TOP CHORD Structural wood sheathing directly applied or 6-0-0 oc purlins.  
BOT CHORD Rigid ceiling directly applied or 10-0-0 oc bracing.

**REACTIONS.** (size) 3=Mechanical, 2=0-3-8, 4=Mechanical  
Max Horz 2=161(LC 12)  
Max Uplift 3=97(LC 12), 2=-110(LC 12), 4=-47(LC 9)  
Max Grav 3=177(LC 1), 2=415(LC 1), 4=127(LC 3)

**FORCES.** (lb) - Max. Comp./Max. Ten. - All forces 250 (lb) or less except when shown.

**NOTES-**

- 1) Wind: ASCE 7-22; Vult=130mph (3-second gust) Vasd=101mph; TCDL=4.2psf; BCDL=3.0psf; h=20ft; Cat. II; Exp B; Encl., GCpi=0.18; MWFRS (envelope) gable end zone and C-C Zone3 -2-0-0 to 1-0-0, Zone1 1-0-0 to 6-11-4 zone; porch left and right exposed;C-C for members and forces & MWFRS for reactions shown; Lumber DOL=1.60 plate grip DOL=1.60
- 2) Building Designer / Project engineer responsible for verifying applied roof live load shown covers rain loading requirements specific to the use of this truss component.
- 3) This truss has been designed for a 10.0 psf bottom chord live load nonconcurrent with any other live loads.
- 4) \* This truss has been designed for a live load of 20.0psf on the bottom chord in all areas where a rectangle 3-6-0 tall by 2-0-0 wide will fit between the bottom chord and any other members.
- 5) Refer to girder(s) for truss to truss connections.
- 6) Provide mechanical connection (by others) of truss to bearing plate capable of withstanding 100 lb uplift at joint(s) 3, 4 except (jt=lb) 2=110.

This item has been digitally signed and sealed by Velez, Joaquin, PE on the date indicated here. Printed copies of this document are not considered signed and sealed and the signature must be verified on any electronic copies.

Joaquin Velez PE No.68182  
MiTek Inc. DBA MiTek USA FL Cert 6634  
16023 Swingley Ridge Rd.  
Chesterfield, MO 63017

Date:

December 23,2025

**WARNING - Verify design parameters and READ NOTES ON THIS AND INCLUDED MITEK REFERENCE PAGE MII-7473 rev. 1/2/2023 BEFORE USE.**

Design valid for use only with MiTek® connectors. This design is based only upon parameters shown, and is for an individual building component, not a truss system. Before use, the building designer must verify the applicability of design parameters and properly incorporate this design into the overall building design. Bracing indicated is to prevent buckling of individual truss web and/or chord members only. Additional temporary and permanent bracing is always required for stability and to prevent collapse with possible personal injury and property damage. For general guidance regarding the fabrication, storage, delivery, erection and bracing of trusses and truss systems, see **ANSI/TPI1 Quality Criteria and DSB-22** available from Truss Plate Institute (www.tpinst.org) and **BCSI Building Component Safety Information** available from the Structural Building Component Association (www.sbcsccomponents.com)

**MiTek®**

16023 Swingley Ridge Rd.  
Chesterfield, MO 63017  
314.434.1200 / MiTek-US.com

Job 5152938	Truss HJ10	Truss Type Diagonal Hip Girder	Qty 4	Ply 1	THIERY RES. Job Reference (optional)	T39616961
----------------	---------------	-----------------------------------	----------	----------	---	-----------

Builders FirstSource (Lake City,FL), Lake City, FL - 32055,

8.830 s Sep 3 2025 MiTek Industries, Inc. Mon Dec 22 07:34:53 2025 Page 1  
ID:qPB6\_vd6KiSva2ixBwiw7Vy6Vgm-xZEcqj4VoOiPicHZxEJvTFCITsjP3JhXkBPebFy6U60

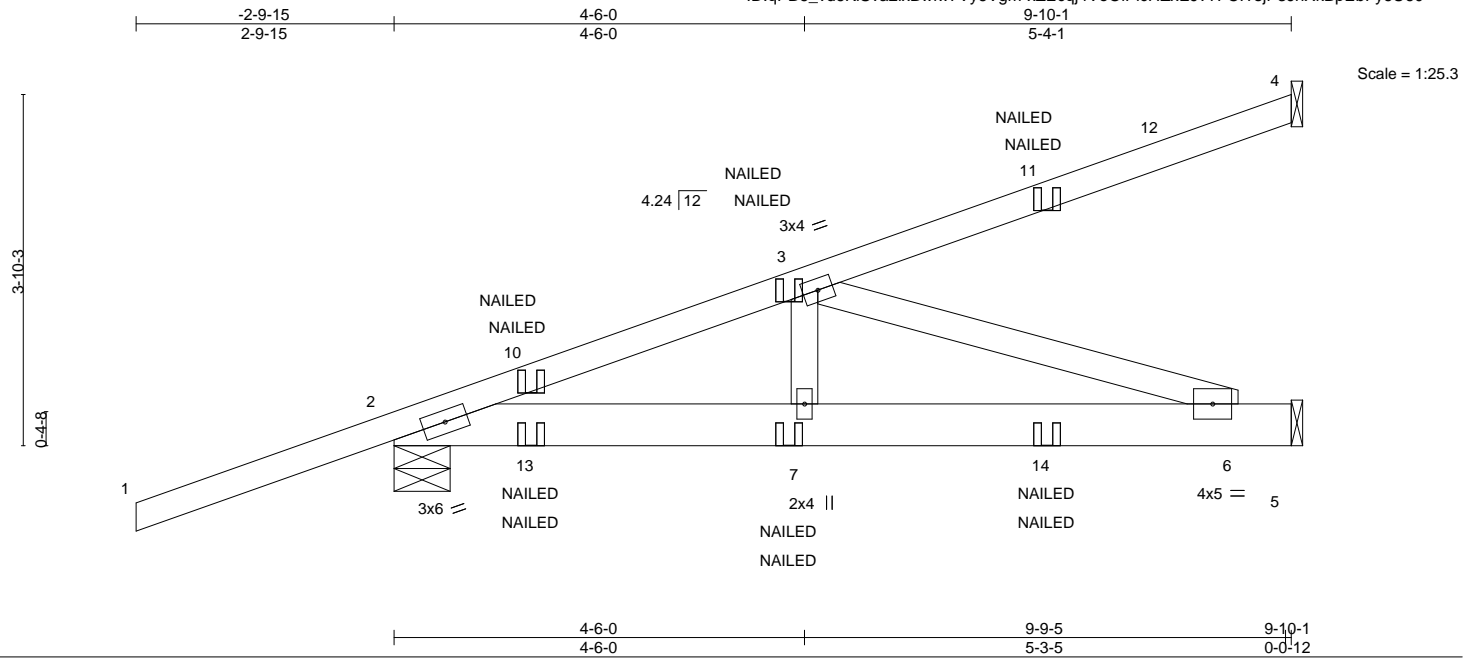

<b>LOADING</b> (psf)	<b>SPACING-</b>	2-0-0	<b>CSI.</b>	<b>DEFL.</b>	in (loc)	l/defl	L/d	<b>PLATES</b>	<b>GRIP</b>
TCLL 20.0	Plate Grip DOL	1.25	TC 0.62	Vert(LL)	0.04 6-7	>999	240	MT20	244/190
TCDL 10.0	Lumber DOL	1.25	BC 0.39	Vert(CT)	-0.05 6-7	>999	180		
BCLL 0.0 *	Rep Stress Incr	NO	WB 0.33	Horz(CT)	0.01 5	n/a	n/a		
BCDL 10.0	Code FBC2023/TPI2014		Matrix-MS					Weight: 52 lb	FT = 20%

<b>LUMBER-</b>	<b>BRACING-</b>
TOP CHORD 2x4 SP No.2	TOP CHORD Structural wood sheathing directly applied or 6-0-0 oc purlins.
BOT CHORD 2x6 SP No.2	BOT CHORD Rigid ceiling directly applied or 10-0-0 oc bracing.
WEBS 2x4 SP No.3	

**REACTIONS.** (size) 4=Mechanical, 2=0-7-6, 5=Mechanical  
 Max Horz 2=180(LC 4)  
 Max Uplift 4=89(LC 4), 2=282(LC 4), 5=166(LC 5)  
 Max Grav 4=161(LC 1), 2=484(LC 1), 5=281(LC 3)

**FORCES.** (lb) - Max. Comp./Max. Ten. - All forces 250 (lb) or less except when shown.  
 TOP CHORD 2-3=-653/369  
 BOT CHORD 2-7=-401/618, 6-7=-401/618  
 WEBS 3-6=-651/422

- NOTES-**
- 1) Wind: ASCE 7-22; Vult=130mph (3-second gust) Vasd=101mph; TCDL=4.2psf; BCDL=3.0psf; h=20ft; Cat. II; Exp B; Encl., GCpi=0.18; MWFRS (envelope) gable end zone; porch left and right exposed; Lumber DOL=1.60 plate grip DOL=1.60
  - 2) Building Designer / Project engineer responsible for verifying applied roof live load shown covers rain loading requirements specific to the use of this truss component.
  - 3) This truss has been designed for a 10.0 psf bottom chord live load nonconcurrent with any other live loads.
  - 4) \* This truss has been designed for a live load of 20.0psf on the bottom chord in all areas where a rectangle 3-6-0 tall by 2-0-0 wide will fit between the bottom chord and any other members.
  - 5) Refer to girder(s) for truss to truss connections.
  - 6) Provide mechanical connection (by others) of truss to bearing plate capable of withstanding 100 lb uplift at joint(s) 4 except (jt=lb) 2=282, 5=166.
  - 7) "NAILED" indicates 3-10d (0.148"x3") or 2-12d (0.148"x3.25") toe-nails per NDS guidelines.
  - 8) In the LOAD CASE(S) section, loads applied to the face of the truss are noted as front (F) or back (B).

**LOAD CASE(S)** Standard  
 1) Dead + Roof Live (balanced): Lumber Increase=1.25, Plate Increase=1.25  
 Uniform Loads (plf)  
 Vert: 1-4=-60, 2-5=-20  
 Concentrated Loads (lb)  
 Vert: 7=5(F=2, B=2) 10=73(F=37, B=37) 11=-69(F=-34, B=-34) 13=81(F=41, B=41) 14=-51(F=-26, B=-26)

This item has been digitally signed and sealed by Velez, Joaquin, PE on the date indicated here. Printed copies of this document are not considered signed and sealed and the signature must be verified on any electronic copies.

Joaquin Velez PE No.68182  
 MiTek Inc. DBA MiTek USA FL Cert 6634  
 16023 Swingley Ridge Rd.  
 Chesterfield, MO 63017  
 Date:

December 23,2025

<p><b>WARNING - Verify design parameters and READ NOTES ON THIS AND INCLUDED MITEK REFERENCE PAGE MII-7473 rev. 1/2/2023 BEFORE USE.</b></p> <p>Design valid for use only with MiTek® connectors. This design is based only upon parameters shown, and is for an individual building component, not a truss system. Before use, the building designer must verify the applicability of design parameters and properly incorporate this design into the overall building design. Bracing indicated is to prevent buckling of individual truss web and/or chord members only. Additional temporary and permanent bracing is always required for stability and to prevent collapse with possible personal injury and property damage. For general guidance regarding the fabrication, storage, delivery, erection and bracing of trusses and truss systems, see <b>ANSI/TPI1 Quality Criteria and DSB-22</b> available from Truss Plate Institute (www.tpinst.org) and <b>BCSI Building Component Safety Information</b> available from the Structural Building Component Association (www.sbcsccomponents.com)</p>	 <p>16023 Swingley Ridge Rd.        Chesterfield, MO 63017        314.434.1200 / MiTek-US.com</p>
--	--

Job 5152938	Truss T01	Truss Type Common	Qty 7	Ply 1	THIERY RES. Job Reference (optional)	T39616962
----------------	--------------	----------------------	----------	----------	---	-----------

Builders FirstSource (Lake City,FL), Lake City, FL - 32055,

8.830 s Sep 3 2025 MiTek Industries, Inc. Mon Dec 22 07:34:54 2025 Page 1

ID:qPB6\_vd6KiSva2ixBwiw7Vy6Vgm-Plo\_1347ZiqGKmmVxq80SIVDG2TjigzrZo8hy6U6?

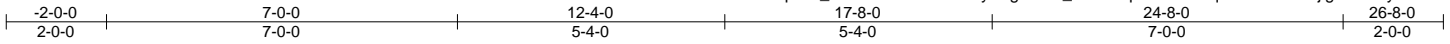

Scale = 1:46.0

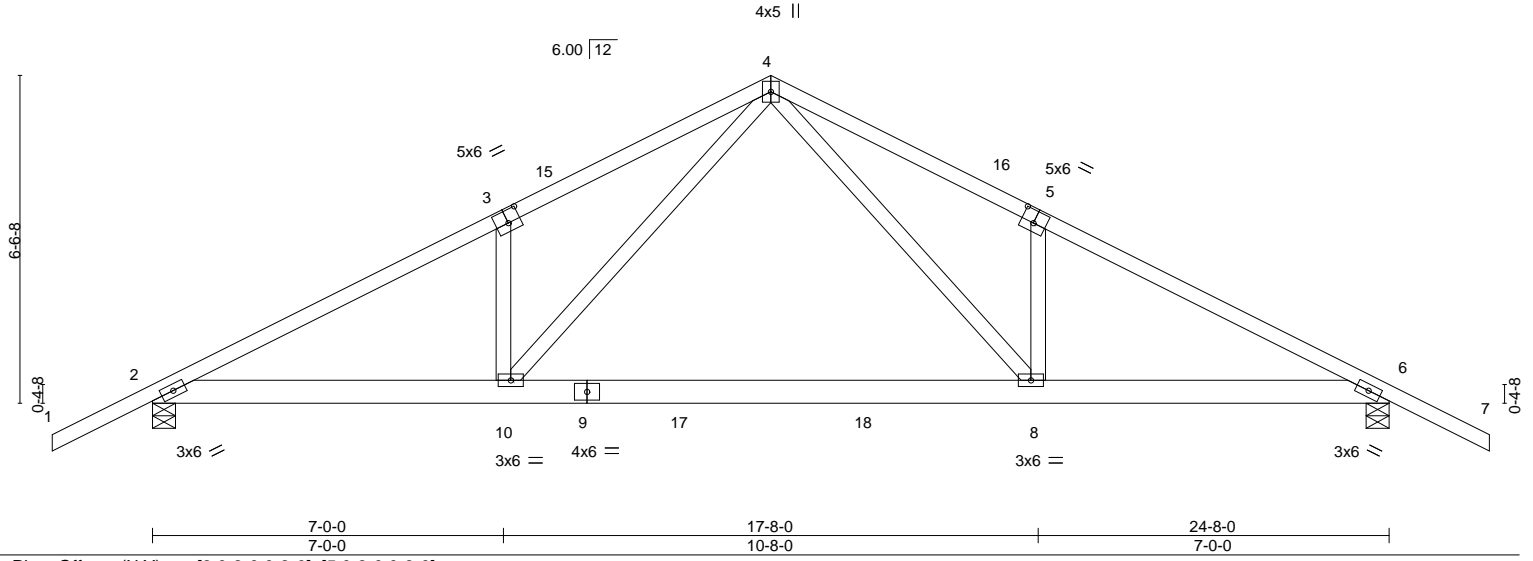

Plate Offsets (X,Y)--	[3:0-3-0,0-3-0], [5:0-3-0,0-3-0]
-----------------------	----------------------------------

<b>LOADING</b> (psf)	<b>SPACING-</b>	2-0-0	<b>CSI.</b>	<b>DEFL.</b>	in (loc)	l/defl	L/d	<b>PLATES</b>	<b>GRIP</b>	
TCLL 20.0	Plate Grip DOL	1.25	TC 0.49	Vert(LL)	-0.23	8-10	>999	240	MT20	244/190
TCDL 10.0	Lumber DOL	1.25	BC 0.46	Vert(CT)	-0.47	8-10	>624	180		
BCLL 0.0 *	Rep Stress Incr	NO	WB 0.54	Horz(CT)	0.04	6	n/a	n/a		
BCDL 10.0	Code	FBC2023/TPI2014	Matrix-MS							
									Weight: 138 lb	FT = 20%

<b>LUMBER-</b>	<b>BRACING-</b>
TOP CHORD 2x4 SP No.2	TOP CHORD Structural wood sheathing directly applied or 3-3-0 oc purlins.
BOT CHORD 2x6 SP 2400F 2.0E or 2x6 SP M 26	BOT CHORD Rigid ceiling directly applied or 10-0-0 oc bracing.
WEBS 2x4 SP No.3	

**REACTIONS.** (size) 2=0-5-8, 6=0-5-8  
 Max Horz 2=120(LC 16)  
 Max Uplift 2=-382(LC 12), 6=-382(LC 13)  
 Max Grav 2=1456(LC 2), 6=1456(LC 2)

**FORCES.** (lb) - Max. Comp./Max. Ten. - All forces 250 (lb) or less except when shown.  
 TOP CHORD 2-3=-2664/618, 3-4=-2658/751, 4-5=-2658/751, 5-6=-2664/617  
 BOT CHORD 2-10=-554/2359, 8-10=-272/1443, 6-8=-434/2318  
 WEBS 4-8=-433/1401, 5-8=-364/249, 4-10=-433/1402, 3-10=-364/249

**NOTES-**

- Unbalanced roof live loads have been considered for this design.
- Wind: ASCE 7-22; Vult=130mph (3-second gust) Vasd=101mph; TCCL=4.2psf; BCDL=3.0psf; h=20ft; Cat. II; Exp B; Encl., GCpi=0.18; MWFRS (envelope) gable end zone and C-C Zone3 -2-0-0 to 0-9-14, Zone1 0-9-14 to 12-4-0, Zone2 12-4-0 to 16-6-15, Zone1 16-6-15 to 26-8-0 zone;C-C for members and forces & MWFRS for reactions shown; Lumber DOL=1.60 plate grip DOL=1.60
- Building Designer / Project engineer responsible for verifying applied roof live load shown covers rain loading requirements specific to the use of this truss component.
- This truss has been designed for a 10.0 psf bottom chord live load nonconcurrent with any other live loads.
- \* This truss has been designed for a live load of 20.0psf on the bottom chord in all areas where a rectangle 3-6-0 tall by 2-0-0 wide will fit between the bottom chord and any other members, with BCDL = 10.0psf.
- Provide mechanical connection (by others) of truss to bearing plate capable of withstanding 100 lb uplift at joint(s) except (jt=lb) 2=382, 6=382.
- In the LOAD CASE(S) section, loads applied to the face of the truss are noted as front (F) or back (B).

**LOAD CASE(S)** Standard

- Dead + Roof Live (balanced): Lumber Increase=1.25, Plate Increase=1.25  
 Uniform Loads (plf)  
 Vert: 1-4=-60, 4-7=-60, 2-10=-20, 8-10=-80(F=-60), 6-8=-20

This item has been digitally signed and sealed by Velez, Joaquin, PE on the date indicated here. Printed copies of this document are not considered signed and sealed and the signature must be verified on any electronic copies.

Joaquin Velez PE No.68182  
 MiTek Inc. DBA MiTek USA FL Cert 6634  
 16023 Swingley Ridge Rd.  
 Chesterfield, MO 63017

Date:  
 December 23,2025

<p><b>WARNING - Verify design parameters and READ NOTES ON THIS AND INCLUDED MITEK REFERENCE PAGE MII-7473 rev. 1/2/2023 BEFORE USE.</b></p> <p>Design valid for use only with MiTek® connectors. This design is based only upon parameters shown, and is for an individual building component, not a truss system. Before use, the building designer must verify the applicability of design parameters and properly incorporate this design into the overall building design. Bracing indicated is to prevent buckling of individual truss web and/or chord members only. Additional temporary and permanent bracing is always required for stability and to prevent collapse with possible personal injury and property damage. For general guidance regarding the fabrication, storage, delivery, erection and bracing of trusses and truss systems, see <b>ANSI/TPI1 Quality Criteria and DSB-22</b> available from Truss Plate Institute (www.tpinst.org) and <b>BCSI Building Component Safety Information</b> available from the Structural Building Component Association (www.sbcsccomponents.com)</p>	<p>16023 Swingley Ridge Rd.          Chesterfield, MO 63017          314.434.1200 / MiTek-US.com</p>
--	--

Job 5152938	Truss T01G	Truss Type Common Supported Gable	Qty 1	Ply 1	THIERY RES. Job Reference (optional)	T39616963
----------------	---------------	--------------------------------------	----------	----------	---	-----------

Builders FirstSource (Lake City,FL), Lake City, FL - 32055,

8.830 s Sep 3 2025 MiTek Industries, Inc. Mon Dec 22 07:34:54 2025 Page 1

ID:qPB6\_vd6KiSva2ixBwiw7Vy6Vgm-Plo\_1347ZiqGKmrMvxq80SIYcG96oqngzrZo8hy6U6?

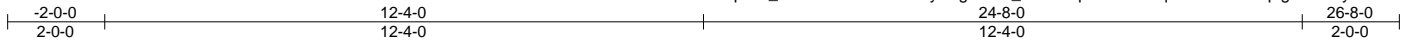

Scale = 1:47.5

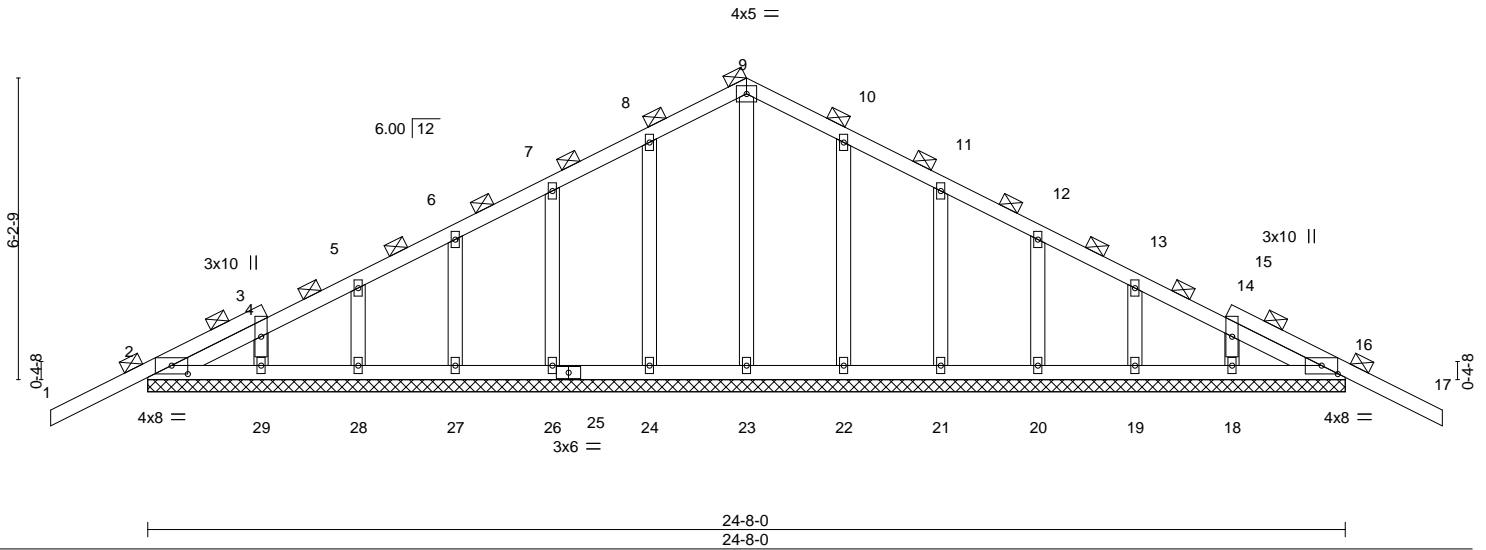

Plate Offsets (X,Y)--	[2:0-4-0,0-2-1], [16:0-4-0,0-2-1]				
<b>LOADING</b> (psf)	<b>SPACING-</b> 2-0-0	<b>CSI.</b>	<b>DEFL.</b> in (loc) l/defl L/d	<b>PLATES</b>	<b>GRIP</b>
TCLL 20.0	Plate Grip DOL 1.25	TC 0.27	Vert(LL) -0.02 17 n/r 120	MT20	244/190
TCDL 10.0	Lumber DOL 1.25	BC 0.04	Vert(CT) -0.03 17 n/r 120		
BCLL 0.0 *	Rep Stress Incr YES	WB 0.09	Horz(CT) 0.00 16 n/a n/a		
BCDL 10.0	Code FBC2023/TPI2014	Matrix-S		Weight: 139 lb	FT = 20%

<b>LUMBER-</b>	<b>BRACING-</b>
TOP CHORD 2x4 SP No.2	TOP CHORD 2-0-0 oc purlins (6-0-0 max.).
BOT CHORD 2x4 SP No.2	BOT CHORD Rigid ceiling directly applied or 10-0-0 oc bracing.
OTHERS 2x4 SP No.3	

**REACTIONS.** All bearings 24-8-0.  
 (lb) - Max Horz 2=114(LC 17)  
 Max Uplift All uplift 100 lb or less at joint(s) 2, 16, 24, 26, 27, 28, 29, 22, 21, 20, 19, 18  
 Max Grav All reactions 250 lb or less at joint(s) 23, 24, 26, 27, 28, 29, 22, 21, 20, 19, 18 except 2=258(LC 1), 16=258(LC 1)

**FORCES.** (lb) - Max. Comp./Max. Ten. - All forces 250 (lb) or less except when shown.

- NOTES-**
- 1) Unbalanced roof live loads have been considered for this design.
  - 2) Wind: ASCE 7-22; Vult=130mph (3-second gust) Vasd=101mph; TCDL=4.2psf; BCDL=3.0psf; h=20ft; Cat. II; Exp B; Encl., GCpi=0.18; MWFRS (envelope) gable end zone and C-C Zone3 zone; C-C for members and forces & MWFRS for reactions shown; Lumber DOL=1.60 plate grip DOL=1.60
  - 3) Truss designed for wind loads in the plane of the truss only. For studs exposed to wind (normal to the face), see Standard Industry Gable End Details as applicable, or consult qualified building designer as per ANSI/TPI 1.
  - 4) Building Designer / Project engineer responsible for verifying applied roof live load shown covers rain loading requirements specific to the use of this truss component.
  - 5) All plates are 2x4 MT20 unless otherwise indicated.
  - 6) Gable requires continuous bottom chord bearing.
  - 7) Gable studs spaced at 2-0-0 oc.
  - 8) This truss has been designed for a 10.0 psf bottom chord live load nonconcurrent with any other live loads.
  - 9) \* This truss has been designed for a live load of 20.0psf on the bottom chord in all areas where a rectangle 3-6-0 tall by 2-0-0 wide will fit between the bottom chord and any other members.
  - 10) Provide mechanical connection (by others) of truss to bearing plate capable of withstanding 100 lb uplift at joint(s) 2, 16, 24, 26, 27, 28, 29, 22, 21, 20, 19, 18.
  - 11) Graphical purlin representation does not depict the size or the orientation of the purlin along the top and/or bottom chord.

This item has been digitally signed and sealed by Velez, Joaquin, PE on the date indicated here. Printed copies of this document are not considered signed and sealed and the signature must be verified on any electronic copies.

Joaquin Velez PE No.68182  
 MiTek Inc. DBA MiTek USA FL Cert 6634  
 16023 Swingley Ridge Rd.  
 Chesterfield, MO 63017  
 Date:

December 23,2025

<p><b>WARNING - Verify design parameters and READ NOTES ON THIS AND INCLUDED MITEK REFERENCE PAGE MII-7473 rev. 1/2/2023 BEFORE USE.</b></p> <p>Design valid for use only with MiTek® connectors. This design is based only upon parameters shown, and is for an individual building component, not a truss system. Before use, the building designer must verify the applicability of design parameters and properly incorporate this design into the overall building design. Bracing indicated is to prevent buckling of individual truss web and/or chord members only. Additional temporary and permanent bracing is always required for stability and to prevent collapse with possible personal injury and property damage. For general guidance regarding the fabrication, storage, delivery, erection and bracing of trusses and truss systems, see <b>ANSI/TPI1 Quality Criteria and DSB-22</b> available from Truss Plate Institute (www.tpinst.org) and <b>BCSI Building Component Safety Information</b> available from the Structural Building Component Association (www.sbcsccomponents.com)</p>	 <p>16023 Swingley Ridge Rd.        Chesterfield, MO 63017        314.434.1200 / MiTek-US.com</p>
--	--

Job 5152938	Truss T02	Truss Type Common	Qty 2	Ply 1	THIERY RES. Job Reference (optional)	T39616964
----------------	--------------	----------------------	----------	----------	---	-----------

Builders FirstSource (Lake City,FL), Lake City, FL - 32055,

8.830 s Sep 3 2025 MiTek Industries, Inc. Mon Dec 22 07:34:55 2025 Page 1

ID:qPB6\_vd6KiSva2ixBwiw7Vy6Vgm-tyMNEP5IK?z7xwQy3fLNZgleWgOIXArqCVILg7y6U6\_



Scale = 1:44.0

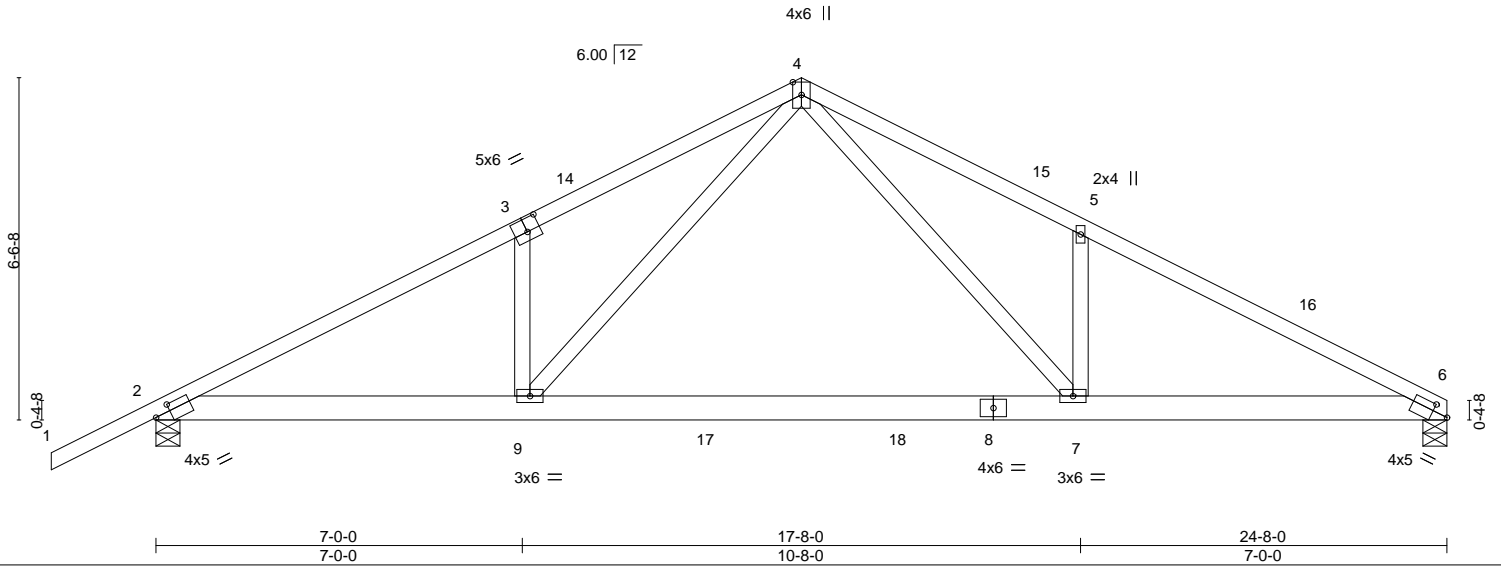

Plate Offsets (X,Y)--	[2:0-3-8,0-1-10], [3:0-3-0,0-3-0], [6:0-3-8,0-1-10]
-----------------------	---

LOADING (psf)	SPACING-	CSI.	DEFL.	in (loc)	l/defl	L/d	PLATES	GRIP
TCLL 20.0	2-0-0	TC 0.52	Vert(LL)	-0.23	7-9	>999	MT20	244/190
TCDL 10.0	Plate Grip DOL 1.25	BC 0.46	Vert(CT)	-0.47	7-9	>626		
BCLL 0.0 *	Lumber DOL 1.25	WB 0.56	Horz(CT)	0.04	6	n/a		
BCDL 10.0	Rep Stress Incr NO	Matrix-MS						
	Code FBC2023/TPI2014						Weight: 135 lb	FT = 20%

LUMBER-	BRACING-
TOP CHORD 2x4 SP No.2	TOP CHORD Structural wood sheathing directly applied or 3-2-14 oc purlins.
BOT CHORD 2x6 SP 2400F 2.0E or 2x6 SP M 26	BOT CHORD Rigid ceiling directly applied or 10-0-0 oc bracing.
WEBS 2x4 SP No.3	

**REACTIONS.** (size) 6=0-5-8, 2=0-5-8  
 Max Horz 2=136(LC 16)  
 Max Uplift 6=330(LC 13), 2=383(LC 12)  
 Max Grav 6=1352(LC 2), 2=1460(LC 2)

**FORCES.** (lb) - Max. Comp./Max. Ten. - All forces 250 (lb) or less except when shown.  
 TOP CHORD 2-3=-2671/624, 3-4=-2666/753, 4-5=-2687/769, 5-6=-2693/649  
 BOT CHORD 2-9=-572/2350, 7-9=-291/1436, 6-7=-496/2346  
 WEBS 4-7=-449/1423, 5-7=-367/250, 4-9=-433/1399, 3-9=-364/249

- NOTES-**
- 1) Unbalanced roof live loads have been considered for this design.
  - 2) Wind: ASCE 7-22; Vult=130mph (3-second gust) Vasd=101mph; TCCL=4.2psf; BCDL=3.0psf; h=20ft; Cat. II; Exp B; Encl., GCpi=0.18; MWFRS (envelope) gable end zone and C-C Zone3 -2-0-0 to 0-9-14, Zone1 0-9-14 to 12-4-0, Zone2 12-4-0 to 16-6-15, Zone1 16-6-15 to 24-8-0 zone;C-C for members and forces & MWFRS for reactions shown; Lumber DOL=1.60 plate grip DOL=1.60
  - 3) Building Designer / Project engineer responsible for verifying applied roof live load shown covers rain loading requirements specific to the use of this truss component.
  - 4) This truss has been designed for a 10.0 psf bottom chord live load nonconcurrent with any other live loads.
  - 5) \* This truss has been designed for a live load of 20.0psf on the bottom chord in all areas where a rectangle 3-6-0 tall by 2-0-0 wide will fit between the bottom chord and any other members, with BCDL = 10.0psf.
  - 6) Provide mechanical connection (by others) of truss to bearing plate capable of withstanding 100 lb uplift at joint(s) except (jt=lb) 6=330, 2=383.
  - 7) In the LOAD CASE(S) section, loads applied to the face of the truss are noted as front (F) or back (B).

**LOAD CASE(S)** Standard  
 1) Dead + Roof Live (balanced): Lumber Increase=1.25, Plate Increase=1.25  
 Uniform Loads (plf)  
 Vert: 1-4=-60, 4-6=-60, 2-9=-20, 7-9=-80(F=-60), 6-7=-20

This item has been digitally signed and sealed by Velez, Joaquin, PE on the date indicated here. Printed copies of this document are not considered signed and sealed and the signature must be verified on any electronic copies.

Joaquin Velez PE No.68182  
 MiTek Inc. DBA MiTek USA FL Cert 6634  
 16023 Swingley Ridge Rd.  
 Chesterfield, MO 63017  
 Date:

December 23,2025

<p><b>WARNING - Verify design parameters and READ NOTES ON THIS AND INCLUDED MITEK REFERENCE PAGE MII-7473 rev. 1/2/2023 BEFORE USE.</b></p> <p>Design valid for use only with MiTek® connectors. This design is based only upon parameters shown, and is for an individual building component, not a truss system. Before use, the building designer must verify the applicability of design parameters and properly incorporate this design into the overall building design. Bracing indicated is to prevent buckling of individual truss web and/or chord members only. Additional temporary and permanent bracing is always required for stability and to prevent collapse with possible personal injury and property damage. For general guidance regarding the fabrication, storage, delivery, erection and bracing of trusses and truss systems, see <b>ANSI/TPI1 Quality Criteria and DSB-22</b> available from Truss Plate Institute (www.tpinst.org) and <b>BCSI Building Component Safety Information</b> available from the Structural Building Component Association (www.sbcsccomponents.com)</p>	 <p>16023 Swingley Ridge Rd.          Chesterfield, MO 63017          314.434.1200 / MiTek-US.com</p>
--	--

Job 5152938	Truss T03	Truss Type Common Girder	Qty 1	Ply 3	THIERY RES. T39616965
----------------	--------------	-----------------------------	----------	----------	--------------------------

Builders FirstSource (Lake City,FL), Lake City, FL - 32055,

8.830 s Sep 3 2025 MiTek Industries, Inc. Mon Dec 22 07:34:56 2025 Page 1

ID:qPB6\_vd6KiSva2ixBwiw7Vy6Vgm-L8wISl6N5J5\_Z4?8cMsc5tqoH4IbGbMzR92uBay6U5z



4x5 ||

Scale = 1:44.8

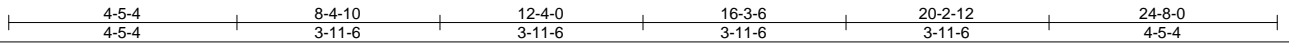
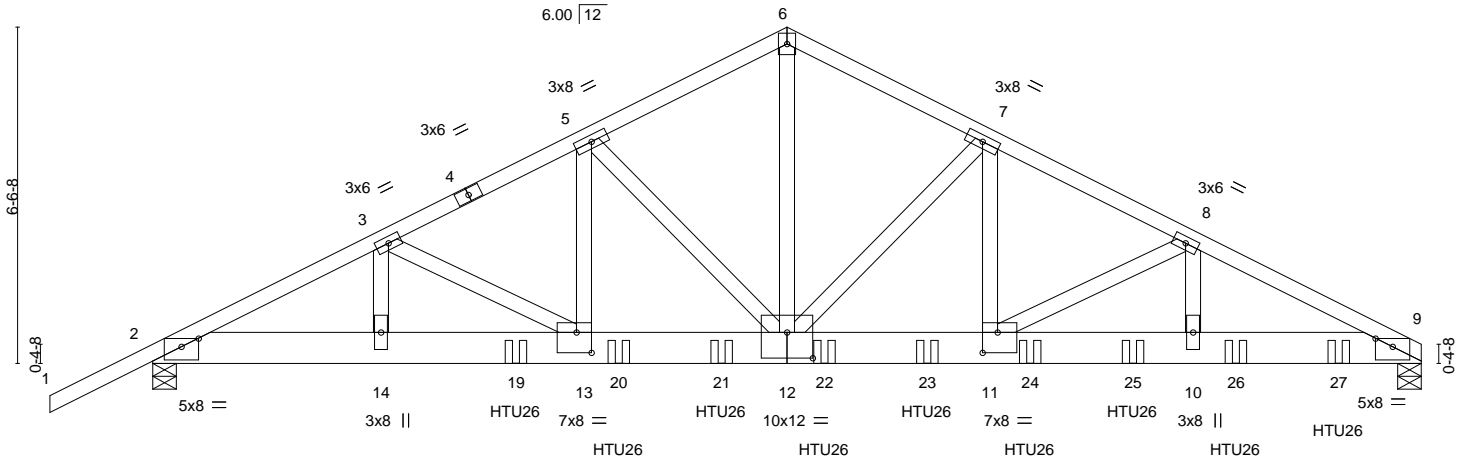

Plate Offsets (X,Y)-- [2:0-4-0,0-1-15], [9:0-4-0,0-1-15], [11:0-3-8,0-4-12], [12:0-6-0,0-6-0], [13:0-3-8,0-4-12]

LOADING (psf)	SPACING-	2-0-0	CSI.	DEFL.	in (loc)	l/defl	L/d	PLATES	GRIP
TCLL 20.0	Plate Grip DOL	1.25	TC 0.58	Vert(LL)	-0.16 11-12	>999	240	MT20	244/190
TCDL 10.0	Lumber DOL	1.25	BC 0.42	Vert(CT)	-0.32 11-12	>916	180		
BCLL 0.0 *	Rep Stress Incr	NO	WB 0.66	Horz(CT)	0.07 9	n/a	n/a		
BCDL 10.0	Code FBC2023/TPI2014		Matrix-MS						
								Weight: 518 lb	FT = 20%

LUMBER-	BRACING-
TOP CHORD 2x4 SP No.2	TOP CHORD Structural wood sheathing directly applied or 4-10-10 oc purlins.
BOT CHORD 2x8 SP 2400F 2.0E	BOT CHORD Rigid ceiling directly applied or 10-0-0 oc bracing.
WEBS 2x4 SP No.3 *Except* 6-12: 2x4 SP No.2	

**REACTIONS.** (size) 9=0-5-8, 2=0-5-8  
 Max Horz 2=136(LC 33)  
 Max Uplift 9=2231(LC 9), 2=2191(LC 8)  
 Max Grav 9=8511(LC 2), 2=6594(LC 1)

**FORCES.** (lb) - Max. Comp./Max. Ten. - All forces 250 (lb) or less except when shown.  
 TOP CHORD 2-3=-14169/4735, 3-5=-13208/4293, 5-6=-10095/3033, 6-7=-10106/3031,  
 7-8=-13254/3732, 8-9=-16529/4429  
 BOT CHORD 2-14=-4279/12637, 13-14=-4279/12637, 12-13=-3816/11782, 11-12=-3221/11822,  
 10-11=-3907/14772, 9-10=-3907/14772  
 WEBS 6-12=-2608/8724, 7-12=-4288/1033, 7-11=-939/4382, 8-11=-3423/792, 8-10=-573/2927,  
 5-12=-4019/1761, 5-13=-1712/4050, 3-13=-976/526, 3-14=-351/702

- NOTES-**
- 3-ply truss to be connected together with 10d (0.131"x3") nails as follows:  
 Top chords connected as follows: 2x4 - 1 row at 0-7-0 oc.  
 Bottom chords connected as follows: 2x8 - 3 rows staggered at 0-4-0 oc.  
 Webs connected as follows: 2x4 - 1 row at 0-9-0 oc.
  - All loads are considered equally applied to all plies, except if noted as front (F) or back (B) face in the LOAD CASE(S) section. Ply to ply connections have been provided to distribute only loads noted as (F) or (B), unless otherwise indicated.
  - Unbalanced roof live loads have been considered for this design.
  - Wind: ASCE 7-22; Vult=130mph (3-second gust) Vasd=101mph; TC DL=4.2psf; TCDL=4.2psf; BCDL=3.0psf; h=20ft; Cat. II; Exp B; Encl., GCpi=0.18; MWFRS (envelope) gable end zone; Lumber DOL=1.60 plate grip DOL=1.60
  - Building Designer / Project engineer responsible for verifying applied roof live load shown covers rain loading requirements specific to the use of this truss component.
  - This truss has been designed for a 10.0 psf bottom chord live load nonconcurrent with any other live loads.
  - \* This truss has been designed for a live load of 20.0psf on the bottom chord in all areas where a rectangle 3-6-0 tall by 2-0-0 wide will fit between the bottom chord and any other members.
  - Provide mechanical connection (by others) of truss to bearing plate capable of withstanding 100 lb uplift at joint(s) except (jt=lb) 9=2231, 2=2191.
  - Use Simpson Strong-Tie HTU26 (20-10d Girder, 20-10dx1 1/2 Truss, Single Ply Girder) or equivalent at 7-0-12 from the left end to connect truss(es) to back face of bottom chord.
  - Use Simpson Strong-Tie HTU26 (20-10d Girder, 11-10dx1 1/2 Truss) or equivalent spaced at 2-0-0 oc max. starting at 9-0-12 from the left end to 23-0-12 to connect truss(es) to back face of bottom chord.
  - Fill all nail holes where hanger is in contact with lumber.

This item has been digitally signed and sealed by Velez, Joaquin, PE on the date indicated here. Printed copies of this document are not considered signed and sealed and the signature must be verified on any electronic copies.

Joaquin Velez PE No.68182  
 MiTek Inc. DBA MiTek USA FL Cert 6634  
 16023 Swingley Ridge Rd.  
 Chesterfield, MO 63017  
 Date:

December 23,2025

Continued on page 2

**LOAD CASE(S)** Standard

**WARNING - Verify design parameters and READ NOTES ON THIS AND INCLUDED MITEK REFERENCE PAGE MII-7473 rev. 1/2/2023 BEFORE USE.**

Design valid for use only with MiTek® connectors. This design is based only upon parameters shown, and is for an individual building component, not a truss system. Before use, the building designer must verify the applicability of design parameters and properly incorporate this design into the overall building design. Bracing indicated is to prevent buckling of individual truss web and/or chord members only. Additional temporary and permanent bracing is always required for stability and to prevent collapse with possible personal injury and property damage. For general guidance regarding the fabrication, storage, delivery, erection and bracing of trusses and truss systems, see **ANSI/TPI1 Quality Criteria and DSB-22** available from Truss Plate Institute (www.tpinst.org) and **BCSI Building Component Safety Information** available from the Structural Building Component Association (www.sbcsccomponents.com)



16023 Swingley Ridge Rd.  
 Chesterfield, MO 63017  
 314.434.1200 / MiTek-US.com

Job 5152938	Truss T03	Truss Type Common Girder	Qty 1	Ply <b>3</b>	THIERY RES.  Job Reference (optional)	T39616965
----------------	--------------	-----------------------------	----------	-----------------	---	-----------

Builders FirstSource (Lake City,FL), Lake City, FL - 32055,

8.830 s Sep 3 2025 MiTek Industries, Inc. Mon Dec 22 07:34:56 2025 Page 2  
ID:qPB6\_vd6KiSva2ixBwiw7Vy6Vgm-L8wISl6N5J5\_Z4?8cMsc5tqoH4IbGbMzR92uBay6U5z

**LOAD CASE(S)** Standard

1) Dead + Roof Live (balanced): Lumber Increase=1.25, Plate Increase=1.25

Uniform Loads (plf)

Vert: 1-6=-60, 6-9=-60, 2-9=-20

Concentrated Loads (lb)

Vert: 19=-2724(B) 20=-1268(B) 21=-1268(B) 22=-1268(B) 23=-1268(B) 24=-1268(B) 25=-1268(B) 26=-1268(B) 27=-1268(B)

**WARNING - Verify design parameters and READ NOTES ON THIS AND INCLUDED MITEK REFERENCE PAGE MII-7473 rev. 1/2/2023 BEFORE USE.**

Design valid for use only with MiTek® connectors. This design is based only upon parameters shown, and is for an individual building component, not a truss system. Before use, the building designer must verify the applicability of design parameters and properly incorporate this design into the overall building design. Bracing indicated is to prevent buckling of individual truss web and/or chord members only. Additional temporary and permanent bracing is always required for stability and to prevent collapse with possible personal injury and property damage. For general guidance regarding the fabrication, storage, delivery, erection and bracing of trusses and truss systems, see **ANSI/TPI1 Quality Criteria and DSB-22** available from Truss Plate Institute ([www.tpinst.org](http://www.tpinst.org)) and **BCSI Building Component Safety Information** available from the Structural Building Component Association ([www.sbcsccomponents.com](http://www.sbcsccomponents.com))

**MiTek**®

16023 Swingley Ridge Rd.  
Chesterfield, MO 63017  
314.434.1200 / MiTek-US.com



Job	Truss	Truss Type	Qty	Ply	THIERY RES.	T39616966
5152938	T04	Half Hip Girder	1	1	Job Reference (optional)	

Builders FirstSource (Lake City,FL), Lake City, FL - 32055,

8.830 s Sep 3 2025 MiTek Industries, Inc. Mon Dec 22 07:34:57 2025 Page 2  
 ID:qPB6\_vd6KiSva2ixBwiw7Vy6Vgm-pKT7f470sdDrBDaLA4Nre5NxfTzb?zp6fpmSk0y6U5y

**LOAD CASE(S)** Standard

1) Dead + Roof Live (balanced): Lumber Increase=1.25, Plate Increase=1.25

Uniform Loads (plf)

Vert: 1-4=-60, 4-10=-60, 2-11=-20

Concentrated Loads (lb)

Vert: 4=-76(F) 7=-117(F) 16=-239(F) 14=-63(F) 6=-117(F) 12=-63(F) 9=-117(F) 19=-117(F) 20=-117(F) 21=-117(F) 22=-117(F) 23=-117(F) 25=-117(F) 26=-117(F) 27=-117(F) 28=-117(F) 29=-117(F) 30=-63(F) 31=-63(F) 32=-63(F) 33=-63(F) 34=-63(F) 35=-63(F) 36=-63(F) 37=-63(F) 38=-63(F) 39=-63(F) 40=-63(F)

**WARNING - Verify design parameters and READ NOTES ON THIS AND INCLUDED MITEK REFERENCE PAGE MII-7473 rev. 1/2/2023 BEFORE USE.**

Design valid for use only with MiTek® connectors. This design is based only upon parameters shown, and is for an individual building component, not a truss system. Before use, the building designer must verify the applicability of design parameters and properly incorporate this design into the overall building design. Bracing indicated is to prevent buckling of individual truss web and/or chord members only. Additional temporary and permanent bracing is always required for stability and to prevent collapse with possible personal injury and property damage. For general guidance regarding the fabrication, storage, delivery, erection and bracing of trusses and truss systems, see **ANSI/TPI1 Quality Criteria and DSB-22** available from Truss Plate Institute ([www.tpinst.org](http://www.tpinst.org)) and **BCSI Building Component Safety Information** available from the Structural Building Component Association ([www.sbcsccomponents.com](http://www.sbcsccomponents.com))

**MiTek®**

16023 Swingley Ridge Rd.  
 Chesterfield, MO 63017  
 314.434.1200 / MiTek-US.com

Job 5152938	Truss T05	Truss Type Half Hip	Qty 1	Ply 1	THIERY RES. T39616967
----------------	--------------	------------------------	----------	----------	--------------------------

Builders FirstSource (Lake City,FL), Lake City, FL - 32055,

8.830 s Sep 3 2025 MiTek Industries, Inc. Mon Dec 22 07:34:57 2025 Page 1

ID:qPB6\_vd6KiSva2ixBwiw7Vy6Vgm-pKT7f470sdDrBDaLA4Nre5Nu3T\_5??A6fnpSk0y6U5y



Scale = 1:58.0

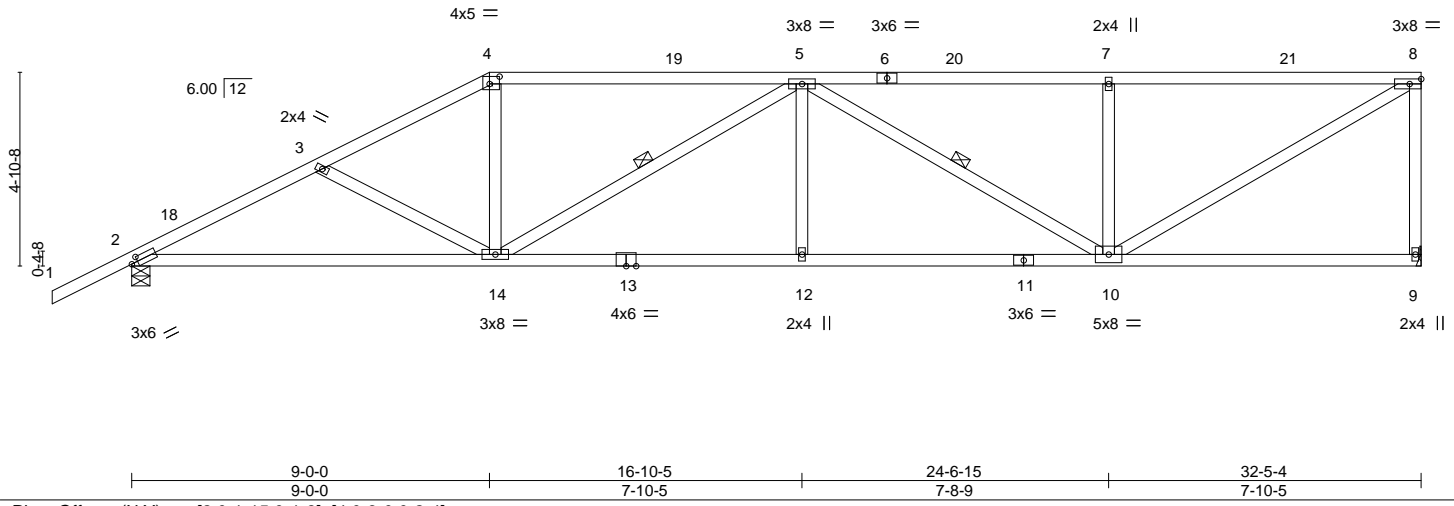

Plate Offsets (X,Y)-- [2:0-1-15,0-1-8], [4:0-3-0,0-2-4]

LOADING (psf)	SPACING-	2-0-0	CSI.	DEFL.	in (loc)	l/defl	L/d	PLATES	GRIP
TCLL 20.0	Plate Grip DOL	1.25	TC 0.90	Vert(LL)	-0.15 14-17	>999	240	MT20	244/190
TCDL 10.0	Lumber DOL	1.25	BC 0.85	Vert(CT)	-0.33 14-17	>999	180		
BCLL 0.0 *	Rep Stress Incr	YES	WB 0.88	Horz(CT)	0.09 9	n/a	n/a		
BCDL 10.0	Code	FBC2023/TPI2014	Matrix-MS					Weight: 173 lb	FT = 20%

**LUMBER-**  
TOP CHORD 2x4 SP No.2  
BOT CHORD 2x4 SP No.2  
WEBS 2x4 SP No.3

**BRACING-**  
TOP CHORD Structural wood sheathing directly applied, except end verticals.  
BOT CHORD Rigid ceiling directly applied or 7-1-1 oc bracing.  
WEBS 1 Row at midpt 5-14, 5-10

**REACTIONS.** (size) 9=Mechanical, 2=0-5-8  
Max Horz 2=207(LC 12)  
Max Uplift 9=-379(LC 9), 2=-395(LC 12)  
Max Grav 9=1288(LC 1), 2=1415(LC 1)

**FORCES.** (lb) - Max. Comp./Max. Ten. - All forces 250 (lb) or less except when shown.  
TOP CHORD 2-3=-2403/648, 3-4=-2132/566, 4-5=-1876/546, 5-7=-1742/508, 7-8=-1742/508, 8-9=-1217/397  
BOT CHORD 2-14=-693/2100, 12-14=-678/2348, 10-12=-678/2348  
WEBS 3-14=-275/169, 4-14=-86/605, 5-14=-646/247, 5-12=0/291, 5-10=-704/296, 7-10=-490/248, 8-10=-578/1985

**NOTES-**

- Unbalanced roof live loads have been considered for this design.
- Wind: ASCE 7-22; Vult=130mph (3-second gust) Vasd=101mph; TCCL=4.2psf; BCDL=3.0psf; h=20ft; Cat. II; Exp B; Encl., GCpi=0.18; MWFRS (envelope) gable end zone and C-C Zone3 -2-0-0 to 1-2-15, Zone1 1-2-15 to 9-0-0, Zone2 9-0-0 to 13-7-1, Zone1 13-7-1 to 32-3-8 zone;C-C for members and forces & MWFRS for reactions shown; Lumber DOL=1.60 plate grip DOL=1.60
- Building Designer / Project engineer responsible for verifying applied roof live load shown covers rain loading requirements specific to the use of this truss component.
- Provide adequate drainage to prevent water ponding.
- This truss has been designed for a 10.0 psf bottom chord live load nonconcurrent with any other live loads.
- \* This truss has been designed for a live load of 20.0psf on the bottom chord in all areas where a rectangle 3-6-0 tall by 2-0-0 wide will fit between the bottom chord and any other members.
- Refer to girder(s) for truss to truss connections.
- Provide mechanical connection (by others) of truss to bearing plate capable of withstanding 100 lb uplift at joint(s) except (jt=lb) 9=379, 2=395.

This item has been digitally signed and sealed by Velez, Joaquin, PE on the date indicated here. Printed copies of this document are not considered signed and sealed and the signature must be verified on any electronic copies.

Joaquin Velez PE No.68182  
MiTek Inc. DBA MiTek USA FL Cert 6634  
16023 Swingley Ridge Rd.  
Chesterfield, MO 63017

Date:

December 23,2025

**WARNING - Verify design parameters and READ NOTES ON THIS AND INCLUDED MITEK REFERENCE PAGE MII-7473 rev. 1/2023 BEFORE USE.**

Design valid for use only with MiTek® connectors. This design is based only upon parameters shown, and is for an individual building component, not a truss system. Before use, the building designer must verify the applicability of design parameters and properly incorporate this design into the overall building design. Bracing indicated is to prevent buckling of individual truss web and/or chord members only. Additional temporary and permanent bracing is always required for stability and to prevent collapse with possible personal injury and property damage. For general guidance regarding the fabrication, storage, delivery, erection and bracing of trusses and truss systems, see **ANSI/TPI1 Quality Criteria and DSB-22** available from Truss Plate Institute (www.tpinst.org) and **BCSI Building Component Safety Information** available from the Structural Building Component Association (www.sbcsccomponents.com)

**MiTek®**

16023 Swingley Ridge Rd.  
Chesterfield, MO 63017  
314.434.1200 / MiTek-US.com

Job 5152938	Truss T06	Truss Type Half Hip	Qty 1	Ply 1	THIERY RES. T39616968
----------------	--------------	------------------------	----------	----------	--------------------------

Builders FirstSource (Lake City,FL), Lake City, FL - 32055,

8.830 s Sep 3 2025 MiTek Industries, Inc. Mon Dec 22 07:34:58 2025 Page 1  
ID:qPB6\_vd6KiSva2ixBwiw7Vy6Vgm-HX1VtQ7edwLioN9Xknu4Alv72tL0kTbGuTX?GSy6U5x

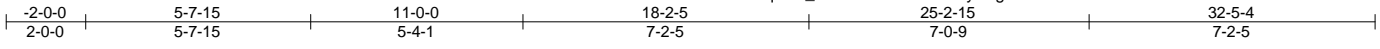

Scale = 1:58.0

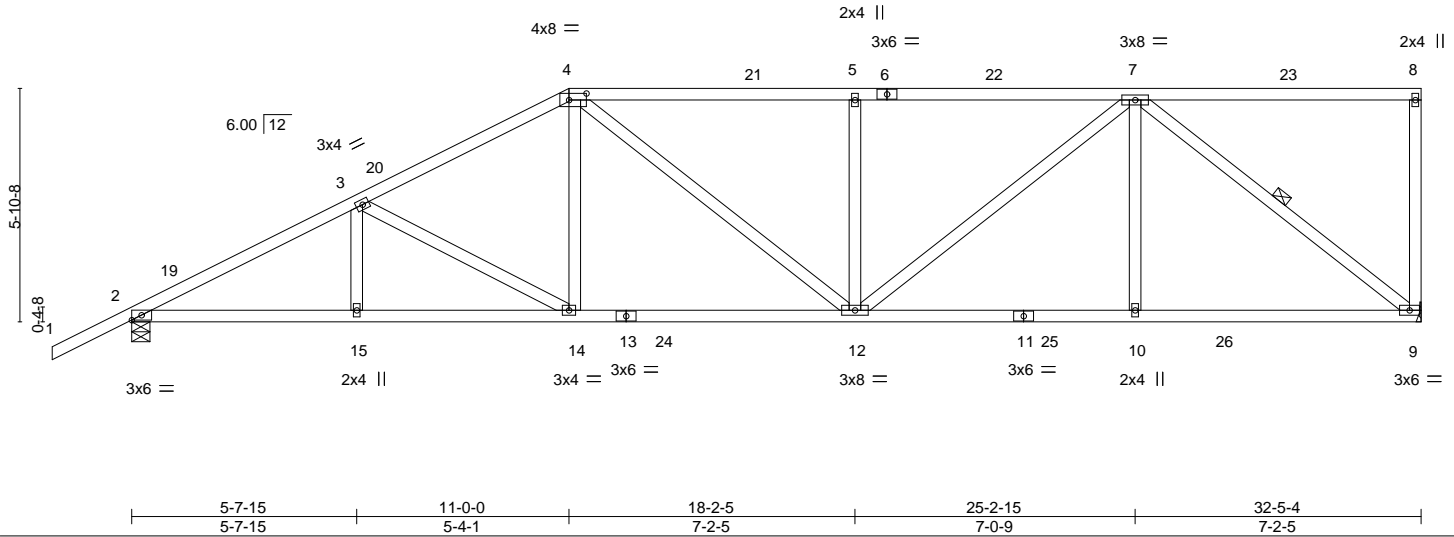

Plate Offsets (X,Y)--	[4:0-5-4,0-2-0]
-----------------------	-----------------

<b>LOADING</b> (psf)	<b>SPACING-</b> 2-0-0	<b>CSI.</b>	<b>DEFL.</b> in (loc) l/defl L/d	<b>PLATES</b>	<b>GRIP</b>
TCLL 20.0	Plate Grip DOL 1.25	TC 0.69	Vert(LL) -0.17 12-14 >999 240	MT20	244/190
TCDL 10.0	Lumber DOL 1.25	BC 0.74	Vert(CT) -0.31 12-14 >999 180		
BCLL 0.0 *	Rep Stress Incr YES	WB 0.80	Horz(CT) 0.10 9 n/a n/a		
BCDL 10.0	Code FBC2023/TPI2014	Matrix-MS			
				Weight: 184 lb	FT = 20%

<b>LUMBER-</b>	<b>BRACING-</b>
TOP CHORD 2x4 SP No.2	TOP CHORD Structural wood sheathing directly applied or 2-11-8 oc purlins, except end verticals.
BOT CHORD 2x4 SP No.2	BOT CHORD Rigid ceiling directly applied or 7-0-13 oc bracing.
WEBS 2x4 SP No.3	WEBS 1 Row at midpt 7-9

**REACTIONS.** (size) 9=Mechanical, 2=0-5-8  
 Max Horz 2=246(LC 12)  
 Max Uplift 9=373(LC 9), 2=394(LC 12)  
 Max Grav 9=1433(LC 2), 2=1510(LC 2)

**FORCES.** (lb) - Max. Comp./Max. Ten. - All forces 250 (lb) or less except when shown.  
 TOP CHORD 2-3=-2632/624, 3-4=-2157/536, 4-5=-2090/532, 5-7=-2090/532  
 BOT CHORD 2-15=-705/2305, 14-15=-705/2305, 12-14=-521/1886, 10-12=-383/1499, 9-10=-383/1499  
 WEBS 3-14=-504/210, 4-14=-61/496, 4-12=-158/367, 5-12=-453/229, 7-12=-282/754,  
 7-10=0/385, 7-9=-1882/481

**NOTES-**

- 1) Unbalanced roof live loads have been considered for this design.
- 2) Wind: ASCE 7-22; Vult=130mph (3-second gust) Vasd=101mph; TCDL=4.2psf; BCDL=3.0psf; h=20ft; Cat. II; Exp B; Encl., GCpi=0.18; MWFRS (envelope) gable end zone and C-C Zone3 -2-0-0 to 1-2-15, Zone1 1-2-15 to 11-0-0, Zone2 11-0-0 to 15-7-1, Zone1 15-7-1 to 32-3-8 zone;C-C for members and forces & MWFRS for reactions shown; Lumber DOL=1.60 plate grip DOL=1.60
- 3) Building Designer / Project engineer responsible for verifying applied roof live load shown covers rain loading requirements specific to the use of this truss component.
- 4) Provide adequate drainage to prevent water ponding.
- 5) This truss has been designed for a 10.0 psf bottom chord live load nonconcurrent with any other live loads.
- 6) \* This truss has been designed for a live load of 20.0psf on the bottom chord in all areas where a rectangle 3-6-0 tall by 2-0-0 wide will fit between the bottom chord and any other members, with BCDL = 10.0psf.
- 7) Refer to girder(s) for truss to truss connections.
- 8) Provide mechanical connection (by others) of truss to bearing plate capable of withstanding 100 lb uplift at joint(s) except (jt=lb) 9=373, 2=394.

This item has been digitally signed and sealed by Velez, Joaquin, PE on the date indicated here. Printed copies of this document are not considered signed and sealed and the signature must be verified on any electronic copies.

Joaquin Velez PE No.68182  
 MiTek Inc. DBA MiTek USA FL Cert 6634  
 16023 Swingley Ridge Rd.  
 Chesterfield, MO 63017

Date:  
 December 23,2025

<p><b>WARNING - Verify design parameters and READ NOTES ON THIS AND INCLUDED MITEK REFERENCE PAGE MII-7473 rev. 1/2/2023 BEFORE USE.</b></p> <p>Design valid for use only with MiTek® connectors. This design is based only upon parameters shown, and is for an individual building component, not a truss system. Before use, the building designer must verify the applicability of design parameters and properly incorporate this design into the overall building design. Bracing indicated is to prevent buckling of individual truss web and/or chord members only. Additional temporary and permanent bracing is always required for stability and to prevent collapse with possible personal injury and property damage. For general guidance regarding the fabrication, storage, delivery, erection and bracing of trusses and truss systems, see <b>ANSI/TPI1 Quality Criteria and DSB-22</b> available from Truss Plate Institute (www.tpinst.org) and <b>BCSI Building Component Safety Information</b> available from the Structural Building Component Association (www.sbcsccomponents.com)</p>	 <p>16023 Swingley Ridge Rd.        Chesterfield, MO 63017        314.434.1200 / MiTek-US.com</p>
--	--

Job 5152938	Truss T07	Truss Type Hip	Qty 1	Ply 1	THIERY RES. Job Reference (optional)	T39616969
----------------	--------------	-------------------	----------	----------	---	-----------

Builders FirstSource (Lake City,FL), Lake City, FL - 32055,

8.830 s Sep 3 2025 MiTek Industries, Inc. Mon Dec 22 07:34:59 2025 Page 1

ID:qPB6\_vd6KiSva2ixBwiw7Vy6Vgm-ljbt4m8GOETZQXkjVQJjWSK\_HgZTz2P77GZovy6U5w

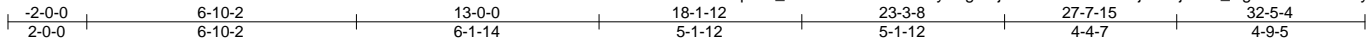

Scale = 1:58.5

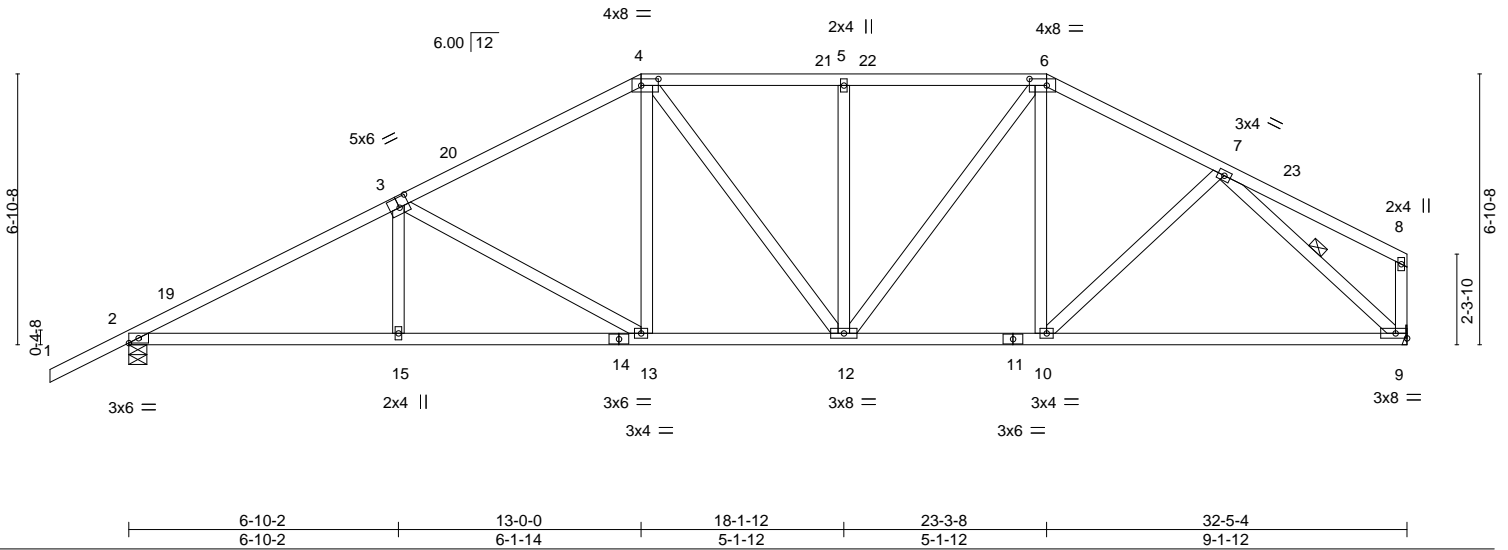

Job 5152938	Truss T08	Truss Type Hip	Qty 1	Ply 1	THIERY RES. Job Reference (optional)	T39616970
----------------	--------------	-------------------	----------	----------	---	-----------

Builders FirstSource (Lake City,FL), Lake City, FL - 32055,

8.830 s Sep 3 2025 MiTek Industries, Inc. Mon Dec 22 07:34:59 2025 Page 1  
ID:qPB6\_vd6KiSva2ixBwiw7Vy6Vgm-ljbt4m8GOETZQXkjlVQJjWSI8HfVT\_vP77GZovy6U5w

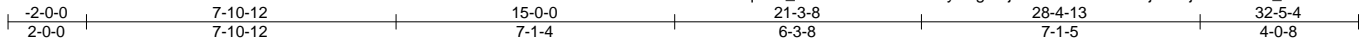

Scale = 1:58.8

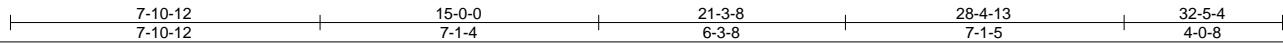
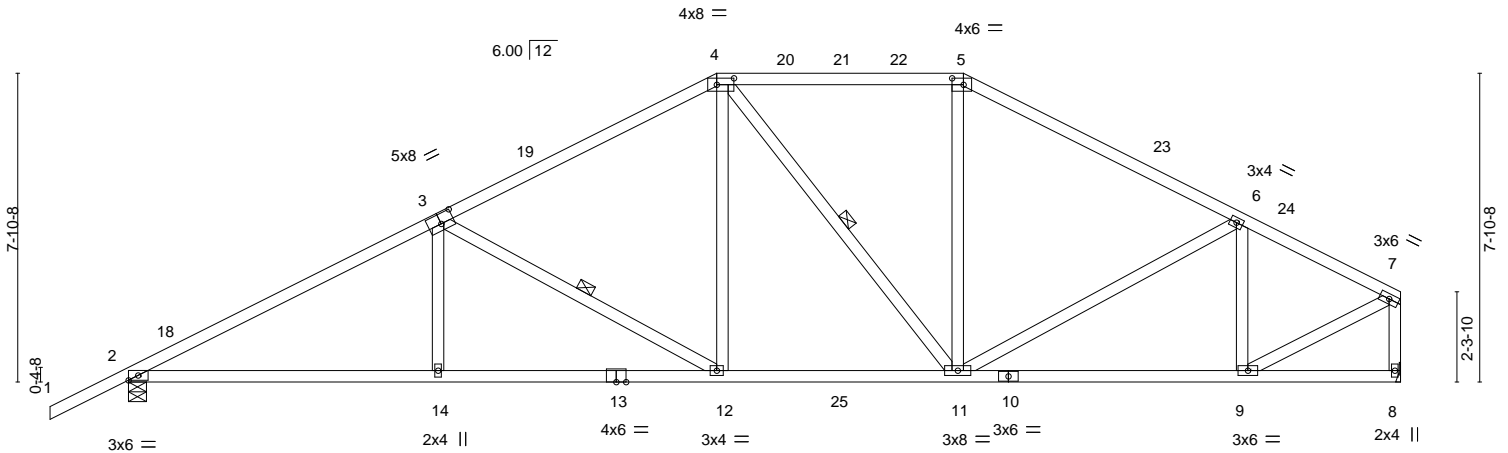

Plate Offsets (X, Y)--	[3:0-4-0,0-3-0], [4:0-5-4,0-2-0], [5:0-3-8,0-2-0]
------------------------	---

<b>LOADING</b> (psf)	<b>SPACING-</b> 2-0-0	<b>CSI.</b>	<b>DEFL.</b> in (loc) l/defl L/d	<b>PLATES</b>	<b>GRIP</b>
TCLL 20.0	Plate Grip DOL 1.25	TC 0.67	Vert(LL) -0.14 14-17 >999 240	MT20	244/190
TCDL 10.0	Lumber DOL 1.25	BC 0.86	Vert(CT) -0.28 14-17 >999 180		
BCLL 0.0 *	Rep Stress Incr YES	WB 0.54	Horz(CT) 0.08 8 n/a n/a		
BCDL 10.0	Code FBC2023/TPI2014	Matrix-MS		Weight: 184 lb	FT = 20%

<b>LUMBER-</b>	<b>BRACING-</b>
TOP CHORD 2x4 SP No.2	TOP CHORD Structural wood sheathing directly applied or 2-10-4 oc purlins, except end verticals.
BOT CHORD 2x4 SP No.2	BOT CHORD Rigid ceiling directly applied or 7-7-1 oc bracing.
WEBS 2x4 SP No.3	WEBS 1 Row at midpt 3-12, 4-11

<b>REACTIONS.</b>	(size) 2=0-5-8, 8=Mechanical
	Max Horz 2=202(LC 12)
	Max Uplift 2=374(LC 12), 8=293(LC 13)
	Max Grav 2=1497(LC 2), 8=1392(LC 2)

<b>FORCES.</b>	(lb) - Max. Comp./Max. Ten. - All forces 250 (lb) or less except when shown.
TOP CHORD	2-3=-2504/556, 3-4=-1780/421, 4-5=-1382/373, 5-6=-1623/360, 6-7=-1437/315, 7-8=-1349/297
BOT CHORD	2-14=-578/2175, 12-14=-578/2174, 11-12=-306/1522, 9-11=-254/1265
WEBS	3-14=0/325, 3-12=-766/314, 4-12=-111/624, 4-11=-303/135, 5-11=-56/383, 6-9=-494/175, 7-9=-287/1420

- NOTES-**
- 1) Unbalanced roof live loads have been considered for this design.
  - 2) Wind: ASCE 7-22; Vult=130mph (3-second gust) Vasd=101mph; TCDL=4.2psf; BCDL=3.0psf; h=20ft; Cat. II; Exp B; Encl., GCpi=0.18; MWFRS (envelope) gable end zone and C-C Zone3 -2-0-0 to 1-2-15, Zone1 1-2-15 to 15-0-0, Zone2 15-0-0 to 19-7-1, Zone1 19-7-1 to 21-3-8, Zone2 21-3-8 to 25-10-9, Zone1 25-10-9 to 32-3-8 zone; C-C for members and forces & MWFRS for reactions shown; Lumber DOL=1.60 plate grip DOL=1.60
  - 3) Building Designer / Project engineer responsible for verifying applied roof live load shown covers rain loading requirements specific to the use of this truss component.
  - 4) Provide adequate drainage to prevent water ponding.
  - 5) This truss has been designed for a 10.0 psf bottom chord live load nonconcurrent with any other live loads.
  - 6) \* This truss has been designed for a live load of 20.0psf on the bottom chord in all areas where a rectangle 3-6-0 tall by 2-0-0 wide will fit between the bottom chord and any other members, with BCDL = 10.0psf.
  - 7) Refer to girder(s) for truss to truss connections.
  - 8) Provide mechanical connection (by others) of truss to bearing plate capable of withstanding 100 lb uplift at joint(s) except (jt=lb) 2=374, 8=293.

This item has been digitally signed and sealed by Velez, Joaquin, PE on the date indicated here. Printed copies of this document are not considered signed and sealed and the signature must be verified on any electronic copies.

Joaquin Velez PE No.68182  
MiTek Inc. DBA MiTek USA FL Cert 6634  
16023 Swingley Ridge Rd.  
Chesterfield, MO 63017

Date: December 23, 2025

<p><b>WARNING - Verify design parameters and READ NOTES ON THIS AND INCLUDED MITEK REFERENCE PAGE MII-7473 rev. 1/2/2023 BEFORE USE.</b></p> <p>Design valid for use only with MiTek® connectors. This design is based only upon parameters shown, and is for an individual building component, not a truss system. Before use, the building designer must verify the applicability of design parameters and properly incorporate this design into the overall building design. Bracing indicated is to prevent buckling of individual truss web and/or chord members only. Additional temporary and permanent bracing is always required for stability and to prevent collapse with possible personal injury and property damage. For general guidance regarding the fabrication, storage, delivery, erection and bracing of trusses and truss systems, see <b>ANSI/TPI1 Quality Criteria and DSB-22</b> available from Truss Plate Institute (www.tpinst.org) and <b>BCSI Building Component Safety Information</b> available from the Structural Building Component Association (www.sbcsccomponents.com)</p>	<p>16023 Swingley Ridge Rd. Chesterfield, MO 63017 314.434.1200 / MiTek-US.com</p>
--	--

Job 5152938	Truss T09	Truss Type Hip	Qty 1	Ply 1	THIERI RES. Job Reference (optional)	T39616971
----------------	--------------	-------------------	----------	----------	---	-----------

Builders FirstSource (Lake City,FL), Lake City, FL - 32055,

8.830 s Sep 3 2025 MiTek Industries, Inc. Mon Dec 22 07:35:00 2025 Page 1

ID:qPB6\_vd6KiSva2ixBwiw7Vy6Vgm-Dv9FI69u9YbQ2hJwrCxYgJ?VPh\_FCRESLn06KLy6U5v

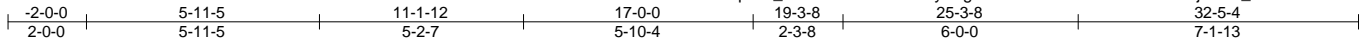

Scale = 1:58.8

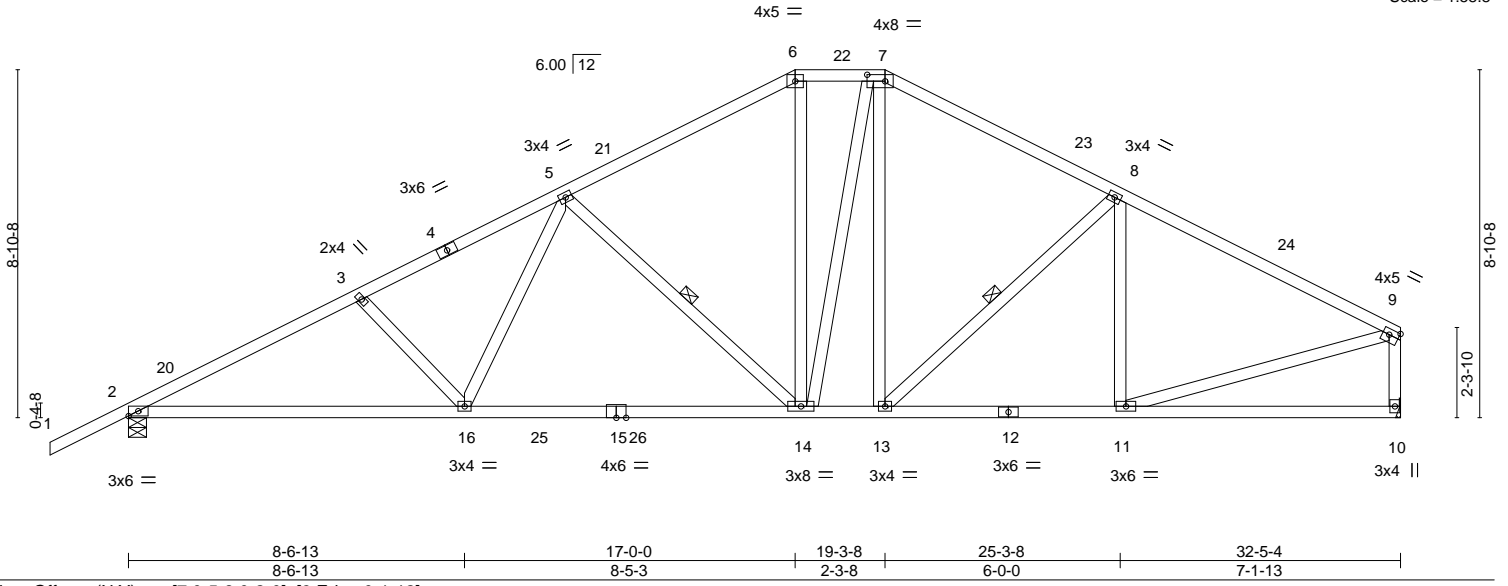

Plate Offsets (X,Y)--	[7:0-5-8,0-2-0], [9:Edge,0-1-12]				
<b>LOADING</b> (psf)	<b>SPACING-</b> 2-0-0	<b>CSI.</b>	<b>DEFL.</b> in (loc) l/defl L/d	<b>PLATES</b>	<b>GRIP</b>
TCLL 20.0	Plate Grip DOL 1.25	TC 0.57	Vert(LL) -0.21 14-16 >999 240	MT20	244/190
TCDL 10.0	Lumber DOL 1.25	BC 0.95	Vert(CT) -0.39 14-16 >999 180		
BCLL 0.0 *	Rep Stress Incr YES	WB 0.54	Horz(CT) 0.07 10 n/a n/a		
BCDL 10.0	Code FBC2023/TPI2014	Matrix-MS		Weight: 202 lb	FT = 20%

<b>LUMBER-</b>	<b>BRACING-</b>
TOP CHORD 2x4 SP No.2	TOP CHORD Structural wood sheathing directly applied or 3-3-11 oc purlins, except end verticals.
BOT CHORD 2x4 SP No.2	BOT CHORD Rigid ceiling directly applied or 2-2-0 oc bracing.
WEBS 2x4 SP No.3	WEBS 1 Row at midpt 5-14, 8-13

**REACTIONS.** (size) 2=0-5-8, 10=Mechanical  
 Max Horz 2=219(LC 12)  
 Max Uplift 2=370(LC 12), 10=289(LC 13)  
 Max Grav 2=1500(LC 2), 10=1383(LC 2)

**FORCES.** (lb) - Max. Comp./Max. Ten. - All forces 250 (lb) or less except when shown.  
 TOP CHORD 2-3=-2553/573, 3-5=-2363/541, 5-6=-1556/384, 6-7=-1334/386, 7-8=-1496/379, 8-9=-1672/351, 9-10=-1271/306  
 BOT CHORD 2-16=-628/2237, 14-16=-459/1820, 13-14=-214/1268, 11-13=-242/1432  
 WEBS 3-16=-299/190, 5-16=-98/586, 5-14=-679/298, 6-14=-108/470, 7-14=-119/363, 8-13=-280/185, 9-11=-232/1406

- NOTES-**
- 1) Unbalanced roof live loads have been considered for this design.
  - 2) Wind: ASCE 7-22; Vult=130mph (3-second gust) Vasd=101mph; TCDL=4.2psf; BCDL=3.0psf; h=20ft; Cat. II; Exp B; Encl., GCpi=0.18; MWFRS (envelope) gable end zone and C-C Zone3 -2-0-0 to 1-2-15, Zone1 1-2-15 to 17-0-0, Zone3 17-0-0 to 19-3-8, Zone2 19-3-8 to 23-10-9, Zone1 23-10-9 to 32-3-8 zone;C-C for members and forces & MWFRS for reactions shown; Lumber DOL=1.60 plate grip DOL=1.60
  - 3) Building Designer / Project engineer responsible for verifying applied roof live load shown covers rain loading requirements specific to the use of this truss component.
  - 4) Provide adequate drainage to prevent water ponding.
  - 5) This truss has been designed for a 10.0 psf bottom chord live load nonconcurrent with any other live loads.
  - 6) \* This truss has been designed for a live load of 20.0psf on the bottom chord in all areas where a rectangle 3-6-0 tall by 2-0-0 wide will fit between the bottom chord and any other members, with BCDL = 10.0psf.
  - 7) Refer to girder(s) for truss to truss connections.
  - 8) Provide mechanical connection (by others) of truss to bearing plate capable of withstanding 100 lb uplift at joint(s) except (jt=lb) 2=370, 10=289.

This item has been digitally signed and sealed by Velez, Joaquin, PE on the date indicated here. Printed copies of this document are not considered signed and sealed and the signature must be verified on any electronic copies.

Joaquin Velez PE No.68182  
 MiTek Inc. DBA MiTek USA FL Cert 6634  
 16023 Swingley Ridge Rd.  
 Chesterfield, MO 63017

Date: December 23,2025

<p><b>WARNING - Verify design parameters and READ NOTES ON THIS AND INCLUDED MITEK REFERENCE PAGE MII-7473 rev. 1/2/2023 BEFORE USE.</b></p> <p>Design valid for use only with MiTek® connectors. This design is based only upon parameters shown, and is for an individual building component, not a truss system. Before use, the building designer must verify the applicability of design parameters and properly incorporate this design into the overall building design. Bracing indicated is to prevent buckling of individual truss web and/or chord members only. Additional temporary and permanent bracing is always required for stability and to prevent collapse with possible personal injury and property damage. For general guidance regarding the fabrication, storage, delivery, erection and bracing of trusses and truss systems, see <b>ANSI/TPI1 Quality Criteria and DSB-22</b> available from Truss Plate Institute (www.tpinst.org) and <b>BCSI Building Component Safety Information</b> available from the Structural Building Component Association (www.sbcsccomponents.com)</p>	<p>16023 Swingley Ridge Rd.        Chesterfield, MO 63017        314.434.1200 / MiTek-US.com</p>
--	--

Job 5152938	Truss T10	Truss Type Common	Qty 3	Ply 1	THIERY RES. Job Reference (optional)	T39616972
----------------	--------------	----------------------	----------	----------	---	-----------

Builders FirstSource (Lake City,FL), Lake City, FL - 32055,

8.830 s Sep 3 2025 MiTek Industries, Inc. Mon Dec 22 07:35:00 2025 Page 1

ID:qPB6\_vd6KiSva2ixBwiw7Vy6Vgm-Dv9F169u9YbQ2hJwrCxYGj?URh?9CRzZLn06KLy6U5v

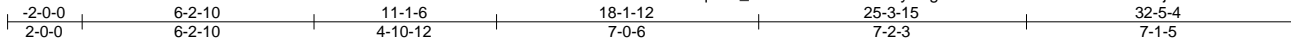

Scale = 1:61.8

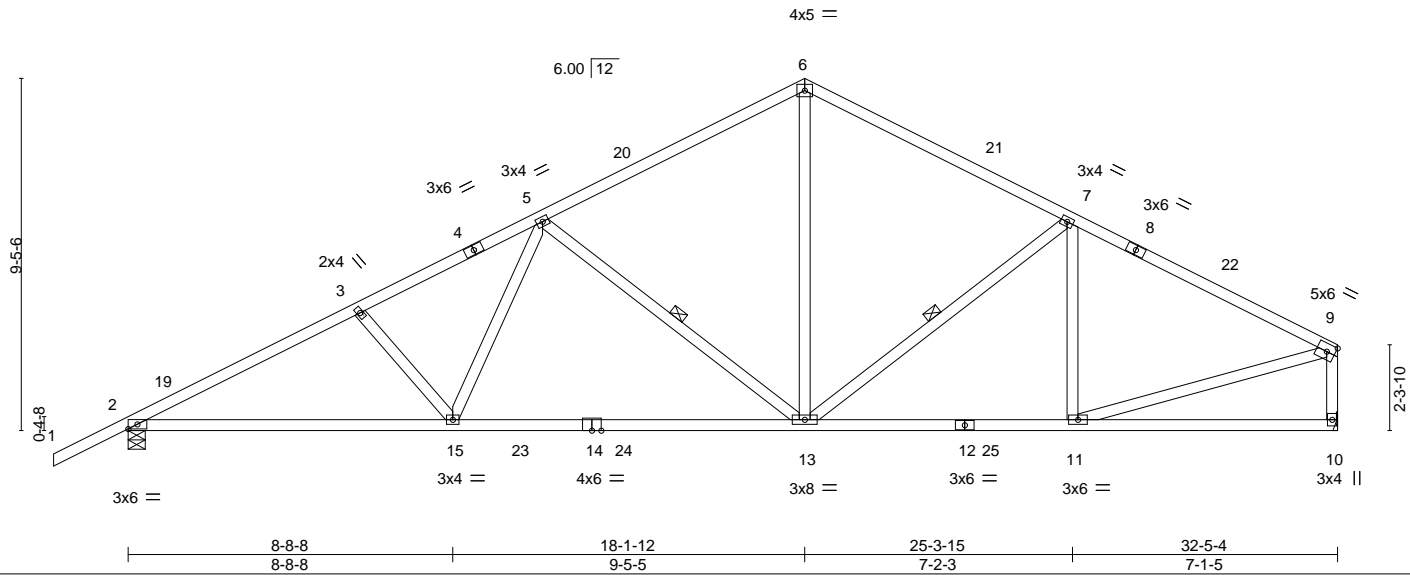

<b>LOADING</b> (psf)	<b>SPACING-</b>	2-0-0	<b>CSI.</b>	<b>DEFL.</b>	in (loc)	l/defl	L/d	<b>PLATES</b>	<b>GRIP</b>
TCLL 20.0	Plate Grip DOL	1.25	TC 0.63	Vert(LL)	-0.26 13-15	>999	240	MT20	244/190
TCDL 10.0	Lumber DOL	1.25	BC 0.89	Vert(CT)	-0.47 13-15	>819	180		
BCLL 0.0 *	Rep Stress Incr	YES	WB 0.55	Horz(CT)	0.07 10	n/a	n/a		
BCDL 10.0	Code FBC2023/TPI2014		Matrix-MS					Weight: 180 lb	FT = 20%

<b>LUMBER-</b>	<b>BRACING-</b>
TOP CHORD 2x4 SP No.2	TOP CHORD Structural wood sheathing directly applied or 3-2-5 oc purlins, except end verticals.
BOT CHORD 2x4 SP No.2 *Except* 2-14: 2x4 SP No.1	BOT CHORD Rigid ceiling directly applied or 7-11-13 oc bracing.
WEBS 2x4 SP No.3	WEBS 1 Row at midpt 5-13, 7-13

**REACTIONS.** (size) 2=0-5-8, 10=Mechanical  
 Max Horz 2=228(LC 12)  
 Max Uplift 2=368(LC 12), 10=286(LC 13)  
 Max Grav 2=1510(LC 2), 10=1410(LC 2)

**FORCES.** (lb) - Max. Comp./Max. Ten. - All forces 250 (lb) or less except when shown.  
 TOP CHORD 2-3=-2566/557, 3-5=-2387/536, 5-6=-1501/360, 6-7=-1507/383, 7-9=-1710/352, 9-10=-1298/303  
 BOT CHORD 2-15=-619/2243, 13-15=-470/1853, 11-13=-245/1469  
 WEBS 3-15=-276/177, 5-15=-91/604, 5-13=-757/329, 6-13=-176/940, 7-13=-323/213, 9-11=-238/1449

- NOTES-**
- 1) Unbalanced roof live loads have been considered for this design.
  - 2) Wind: ASCE 7-22; Vult=130mph (3-second gust) Vasd=101mph; TCCL=4.2psf; BCDL=3.0psf; h=20ft; Cat. II; Exp B; Encl., GCpi=0.18; MWFRS (envelope) gable end zone and C-C Zone3 -2-0-0 to 1-2-15, Zone1 1-2-15 to 18-1-12, Zone2 18-1-12 to 22-8-13, Zone1 22-8-13 to 32-3-8 zone;C-C for members and forces & MWFRS for reactions shown; Lumber DOL=1.60 plate grip DOL=1.60
  - 3) Building Designer / Project engineer responsible for verifying applied roof live load shown covers rain loading requirements specific to the use of this truss component.
  - 4) This truss has been designed for a 10.0 psf bottom chord live load nonconcurrent with any other live loads.
  - 5) \* This truss has been designed for a live load of 20.0psf on the bottom chord in all areas where a rectangle 3-6-0 tall by 2-0-0 wide will fit between the bottom chord and any other members, with BCDL = 10.0psf.
  - 6) Refer to girder(s) for truss to truss connections.
  - 7) Provide mechanical connection (by others) of truss to bearing plate capable of withstanding 100 lb uplift at joint(s) except (jt=lb) 2=368, 10=286.

This item has been digitally signed and sealed by Velez, Joaquin, PE on the date indicated here. Printed copies of this document are not considered signed and sealed and the signature must be verified on any electronic copies.

Joaquin Velez PE No.68182  
 MiTek Inc. DBA MiTek USA FL Cert 6634  
 16023 Swingley Ridge Rd.  
 Chesterfield, MO 63017

Date: December 23,2025

<p><b>WARNING - Verify design parameters and READ NOTES ON THIS AND INCLUDED MITEK REFERENCE PAGE MII-7473 rev. 1/2/2023 BEFORE USE.</b></p> <p>Design valid for use only with MiTek® connectors. This design is based only upon parameters shown, and is for an individual building component, not a truss system. Before use, the building designer must verify the applicability of design parameters and properly incorporate this design into the overall building design. Bracing indicated is to prevent buckling of individual truss web and/or chord members only. Additional temporary and permanent bracing is always required for stability and to prevent collapse with possible personal injury and property damage. For general guidance regarding the fabrication, storage, delivery, erection and bracing of trusses and truss systems, see <b>ANSI/TPI1 Quality Criteria and DSB-22</b> available from Truss Plate Institute (www.tpinst.org) and <b>BCSI Building Component Safety Information</b> available from the Structural Building Component Association (www.sbcsccomponents.com)</p>	<p>16023 Swingley Ridge Rd.        Chesterfield, MO 63017        314.434.1200 / MiTek-US.com</p>
--	--



Job 5152938	Truss T12	Truss Type Roof Special	Qty 6	Ply 1	THIERY RES. Job Reference (optional)	T39616974
----------------	--------------	----------------------------	----------	----------	---	-----------

Builders FirstSource (Lake City,FL), Lake City, FL - 32055,

8.830 s Sep 3 2025 MiTek Industries, Inc. Mon Dec 22 07:35:02 2025 Page 1

ID:qPB6\_vd6KiSva2ixBwiw7Vy6Vgm-AIH0joB8h9r7H?Tlzd0L84muUlpqNCsp5VDPEy6U5t



Scale = 1:67.7

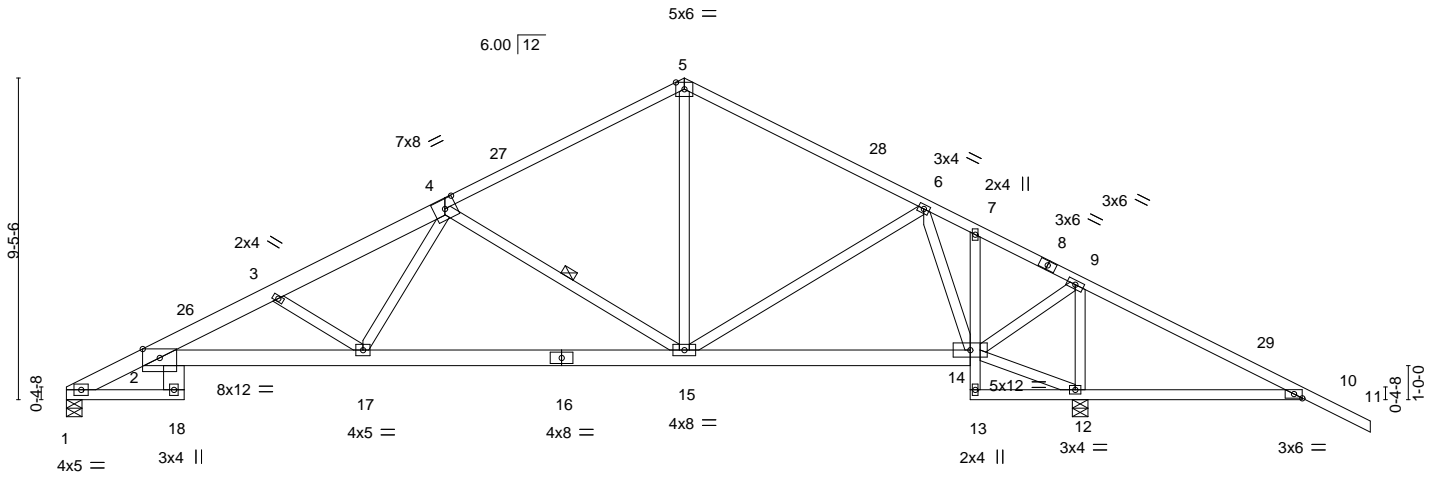

Plate Offsets (X,Y)--	[2:0-6-0,0-3-2], [4:0-4-0,0-3-4], [10:0-2-15,Edge]
-----------------------	--

LOADING (psf)	SPACING-	CSi.	DEFL.	PLATES	GRIP
TCLL 20.0	2-0-0	TC 0.89	in (loc) l/defl L/d	MT20	244/190
TCDL 10.0	Plate Grip DOL 1.25	BC 0.62	Vert(LL) 0.26 2-17 >999 240		
BCLL 0.0 *	Lumber DOL 1.25	WB 0.44	Vert(CT) -0.52 2-17 >690 180		
BCDL 10.0	Rep Stress Incr YES	Matrix-MS	Horz(CT) 0.29 12 n/a n/a		
	Code FBC2023/TPI2014			Weight: 227 lb	FT = 20%

LUMBER-	BRACING-
TOP CHORD 2x4 SP No.2 *Except* 1-4: 2x6 SP 2400F 2.0E or 2x6 SP M 26	TOP CHORD Structural wood sheathing directly applied or 2-2-0 oc purlins.
BOT CHORD 2x4 SP No.2 *Except* 2-18: 2x8 SP 2400F 2.0E, 2-16: 2x6 SP 2400F 2.0E or 2x6 SP M 26	BOT CHORD Rigid ceiling directly applied or 6-0-0 oc bracing.
WEBS 2x4 SP No.3	WEBS 1 Row at midpt 4-15

REACTIONS.
(size) 1=0-5-8, 12=0-5-8
Max Horz 1=-185(LC 13)
Max Uplift 1=-283(LC 12), 12=-481(LC 13)
Max Grav 1=1106(LC 1), 12=1912(LC 1)

FORCES.
(lb) - Max. Comp./Max. Ten. - All forces 250 (lb) or less except when shown.
TOP CHORD 2-22=-558/245, 2-3=-2852/788, 3-4=-2367/650, 4-5=-1075/310, 5-6=-1074/334, 6-7=-406/139, 7-9=-461/146, 9-10=-540/856
BOT CHORD 2-17=-819/2722, 15-17=-457/1651, 14-15=-80/572, 10-12=-683/585
WEBS 3-17=-832/331, 4-17=-194/834, 4-15=-931/413, 5-15=-137/567, 6-15=-177/354, 6-14=-1007/450, 12-14=-656/585, 9-14=-200/1148, 9-12=-1519/373

- NOTES-**
- 1) Unbalanced roof live loads have been considered for this design.
  - 2) Wind: ASCE 7-22; Vult=130mph (3-second gust) Vasd=101mph; TCDL=4.2psf; BCDL=3.0psf; h=20ft; Cat. II; Exp B; Encl., GCpi=0.18; MWFRS (envelope) gable end zone and C-C Zone3 0-2-12 to 3-10-5, Zone1 3-10-5 to 18-1-12, Zone2 18-1-12 to 23-3-5, Zone1 23-3-5 to 38-3-8 zone; cantilever right exposed ;C-C for members and forces & MWFRS for reactions shown; Lumber DOL=1.60 plate grip DOL=1.60
  - 3) Building Designer / Project engineer responsible for verifying applied roof live load shown covers rain loading requirements specific to the use of this truss component.
  - 4) This truss has been designed for a 10.0 psf bottom chord live load nonconcurrent with any other live loads.
  - 5) \* This truss has been designed for a live load of 20.0psf on the bottom chord in all areas where a rectangle 3-6-0 tall by 2-0-0 wide will fit between the bottom chord and any other members.
  - 6) Provide mechanical connection (by others) of truss to bearing plate capable of withstanding 100 lb uplift at joint(s) except (jt=lb) 1=283, 12=481.

This item has been digitally signed and sealed by Velez, Joaquin, PE on the date indicated here. Printed copies of this document are not considered signed and sealed and the signature must be verified on any electronic copies.

Joaquin Velez PE No.68182  
MiTek Inc. DBA MiTek USA FL Cert 6634  
16023 Swingley Ridge Rd.  
Chesterfield, MO 63017

Date: December 23,2025

<p><b>WARNING - Verify design parameters and READ NOTES ON THIS AND INCLUDED MITEK REFERENCE PAGE MII-7473 rev. 1/2/2023 BEFORE USE.</b></p> <p>Design valid for use only with MiTek® connectors. This design is based only upon parameters shown, and is for an individual building component, not a truss system. Before use, the building designer must verify the applicability of design parameters and properly incorporate this design into the overall building design. Bracing indicated is to prevent buckling of individual truss web and/or chord members only. Additional temporary and permanent bracing is always required for stability and to prevent collapse with possible personal injury and property damage. For general guidance regarding the fabrication, storage, delivery, erection and bracing of trusses and truss systems, see <b>ANSI/TPI1 Quality Criteria and DSB-22</b> available from Truss Plate Institute (www.tpinst.org) and <b>BCSI Building Component Safety Information</b> available from the Structural Building Component Association (www.sbcsccomponents.com)</p>	<p>16023 Swingley Ridge Rd. Chesterfield, MO 63017 314.434.1200 / MiTek-US.com</p>
--	--

Job 5152938	Truss T13	Truss Type Hip Girder	Qty 1	Ply 1	THIERY RES. Job Reference (optional)	T39616975
----------------	--------------	--------------------------	----------	----------	---	-----------

Builders FirstSource (Lake City,FL), Lake City, FL - 32055,

8.830 s Sep 3 2025 MiTek Industries, Inc. Mon Dec 22 07:35:03 2025 Page 1

ID:qPB6\_vd6KiSva2ixBwiw7Vy6Vgm-eUrOw8BmSTz\_v82UXKUFIMdwku9zPjB?2IEmxgy6U5s



Scale = 1:54.7

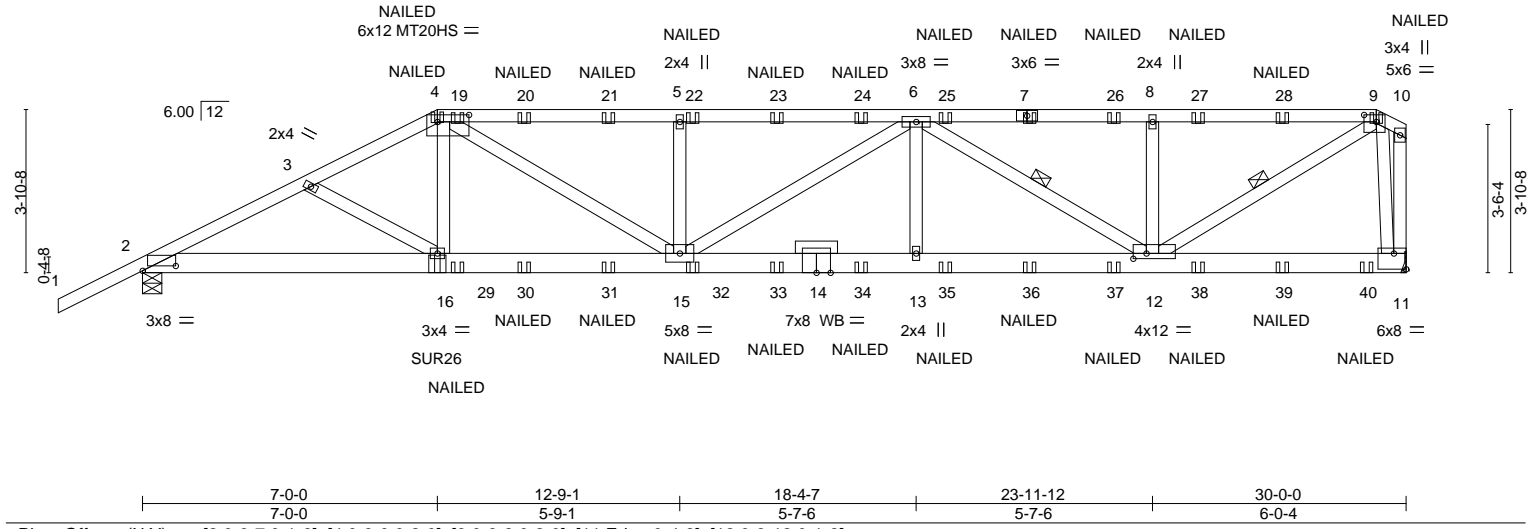

Plate Offsets (X, Y)--	[2:0-9-7,0-1-6], [4:0-9-0,0-2-0], [9:0-3-8,0-2-0], [11:Edge,0-4-8], [12:0-3-12,0-1-8]
------------------------	---

LOADING (psf)	SPACING-	CSi.	DEFL.	PLATES	GRIP
TCLL 20.0	2-0-0	TC 0.95	in (loc) l/defl L/d	MT20	244/190
TCDL 10.0	Plate Grip DOL 1.25	BC 0.37	Vert(LL) 0.32 13-15 >999 240	MT20HS	187/143
BCLL 0.0 *	Lumber DOL 1.25	WB 0.84	Vert(CT) -0.47 13-15 >762 180		
BCDL 10.0	Rep Stress Incr NO	Matrix-MS	Horz(CT) 0.08 11 n/a n/a		
	Code FBC2023/TPI2014			Weight: 190 lb	FT = 20%

LUMBER-	BRACING-
TOP CHORD 2x4 SP No.2 *Except* 4-7: 2x4 SP 2700F 2.2E or 2x4 SP 2850F 2.0E or 2x4 SP M 31	TOP CHORD Structural wood sheathing directly applied, except end verticals.
BOT CHORD 2x6 SP 2400F 2.0E or 2x6 SP M 26	BOT CHORD Rigid ceiling directly applied or 6-1-14 oc bracing.
WEBS 2x4 SP No.3 *Except* 9-12: 2x4 SP No.2	WEBS 1 Row at midpt 6-12, 9-12
OTHERS 2x4 SP No.3	

**REACTIONS.** (size) 2=0-5-8, 11=Mechanical  
 Max Horz 2=162(LC 8)  
 Max Uplift 2=-1128(LC 8), 11=-1278(LC 5)  
 Max Grav 2=2409(LC 21), 11=2585(LC 1)

**FORCES.** (lb) - Max. Comp./Max. Ten. - All forces 250 (lb) or less except when shown.  
 TOP CHORD 2-3=-4698/2295, 3-4=-4535/2258, 4-5=-5487/2746, 5-6=-5487/2746, 6-8=-3551/1767, 8-9=-3551/1767  
 BOT CHORD 2-16=-2124/4154, 15-16=-2057/4062, 13-15=-2634/5292, 12-13=-2634/5292, 11-12=-219/435  
 WEBS 4-16=-299/711, 4-15=-864/1711, 5-15=-727/392, 6-13=-123/470, 6-12=-2052/1042, 8-12=-681/369, 9-12=-1849/3730, 9-11=-2467/1245

- NOTES-**
- Unbalanced roof live loads have been considered for this design.
  - Wind: ASCE 7-22; Vult=130mph (3-second gust) Vasd=101mph; TCDL=4.2psf; BCDL=3.0psf; h=20ft; Cat. II; Exp B; Encl., GCpi=0.18; MWFRS (envelope) gable end zone; Lumber DOL=1.60 plate grip DOL=1.60
  - Building Designer / Project engineer responsible for verifying applied roof live load shown covers rain loading requirements specific to the use of this truss component.
  - Provide adequate drainage to prevent water ponding.
  - All plates are MT20 plates unless otherwise indicated.
  - This truss has been designed for a 10.0 psf bottom chord live load nonconcurrent with any other live loads.
  - \* This truss has been designed for a live load of 20.0psf on the bottom chord in all areas where a rectangle 3-6-0 tall by 2-0-0 wide will fit between the bottom chord and any other members.
  - Refer to girder(s) for truss to truss connections.
  - Provide mechanical connection (by others) of truss to bearing plate capable of withstanding 100 lb uplift at joint(s) except (jt=lb) 2=1128, 11=1278.
  - Use Simpson Strong-Tie SUR26 (6-10dx1 1/2 Girder, 6-10dx1 1/2 Truss, Single Ply Girder) or equivalent at 7-0-0 from the left end to connect truss(es) to back face of bottom chord, skewed 45.0 deg.to the right, sloping 0.0 deg. down.
  - Fill all nail holes where hanger is in contact with lumber.
  - "NAILED" indicates 3-10d (0.148"x3") or 2-12d (0.148"x3.25") toe-nails per NDS guidelines.
  - In the LOAD CASE(S) section, loads applied to the face of the truss are noted as front (F) or back (B).

This item has been digitally signed and sealed by Velez, Joaquin, PE on the date indicated here. Printed copies of this document are not considered signed and sealed and the signature must be verified on any electronic copies.

Joaquin Velez PE No.68182  
 MiTek Inc. DBA MiTek USA FL Cert 6634  
 16023 Swingley Ridge Rd.  
 Chesterfield, MO 63017  
 Date:

December 23,2025

**LOAD CASE(S)** Standard

**WARNING - Verify design parameters and READ NOTES ON THIS AND INCLUDED MITEK REFERENCE PAGE MII-7473 rev. 1/2/2023 BEFORE USE.**  
 Design valid for use only with MiTek® connectors. This design is based only upon parameters shown, and is for an individual building component, not a truss system. Before use, the building designer must verify the applicability of design parameters and properly incorporate this design into the overall building design. Bracing indicated is to prevent buckling of individual truss web and/or chord members only. Additional temporary and permanent bracing is always required for stability and to prevent collapse with possible personal injury and property damage. For general guidance regarding the fabrication, storage, delivery, erection and bracing of trusses and truss systems, see **ANSI/TPI1 Quality Criteria and DSB-22** available from Truss Plate Institute (www.tpinst.org) and **BCSI Building Component Safety Information** available from the Structural Building Component Association (www.sbcsccomponents.com)



Job	Truss	Truss Type	Qty	Ply	THIERY RES.	T39616975
5152938	T13	Hip Girder	1	1	Job Reference (optional)	

Builders FirstSource (Lake City,FL), Lake City, FL - 32055,

8.830 s Sep 3 2025 MiTek Industries, Inc. Mon Dec 22 07:35:03 2025 Page 2  
ID:qPB6\_vd6KiSva2ixBwiv7Vy6Vgm-eUrOw8BmSTz\_v82UXKUFtMdwku9zPjB?2IEmxgy6U5s

**LOAD CASE(S)** Standard

1) Dead + Roof Live (balanced): Lumber Increase=1.25, Plate Increase=1.25

Uniform Loads (plf)

Vert: 1-4=-60, 4-9=-60, 9-10=-60, 2-11=-20

Concentrated Loads (lb)

Vert: 4=-76(B) 7=-117(B) 9=-123(B) 16=-239(B) 19=-117(B) 20=-117(B) 21=-117(B) 22=-117(B) 23=-117(B) 24=-117(B) 25=-117(B) 26=-117(B) 27=-117(B) 28=-117(B) 29=-63(B) 30=-63(B) 31=-63(B) 32=-63(B) 33=-63(B) 34=-63(B) 35=-63(B) 36=-63(B) 37=-63(B) 38=-63(B) 39=-63(B) 40=-65(B)

**WARNING - Verify design parameters and READ NOTES ON THIS AND INCLUDED MITEK REFERENCE PAGE MII-7473 rev. 1/2/2023 BEFORE USE.**

Design valid for use only with MiTek® connectors. This design is based only upon parameters shown, and is for an individual building component, not a truss system. Before use, the building designer must verify the applicability of design parameters and properly incorporate this design into the overall building design. Bracing indicated is to prevent buckling of individual truss web and/or chord members only. Additional temporary and permanent bracing is always required for stability and to prevent collapse with possible personal injury and property damage. For general guidance regarding the fabrication, storage, delivery, erection and bracing of trusses and truss systems, see **ANSI/TPI1 Quality Criteria and DSB-22** available from Truss Plate Institute ([www.tpinst.org](http://www.tpinst.org)) and **BCSI Building Component Safety Information** available from the Structural Building Component Association ([www.sbcsccomponents.com](http://www.sbcsccomponents.com))

**MiTek**®

16023 Swingley Ridge Rd.  
Chesterfield, MO 63017  
314.434.1200 / [MiTek-US.com](http://MiTek-US.com)

Job 5152938	Truss T14	Truss Type Hip	Qty 1	Ply 1	THIERY RES.	T39616976
----------------	--------------	-------------------	----------	----------	-------------	-----------

Builders FirstSource (Lake City,FL), Lake City, FL - 32055,

8.830 s Sep 3 2025 MiTek Industries, Inc. Mon Dec 22 07:35:03 2025 Page 1

ID:qPB6\_vd6KiSva2ixBwiw7Vy6Vgm-eUrOw8BmSTz\_v82UXKUfMd1Vu1QPp0?2IEmxgy6U5s



Scale = 1:53.8

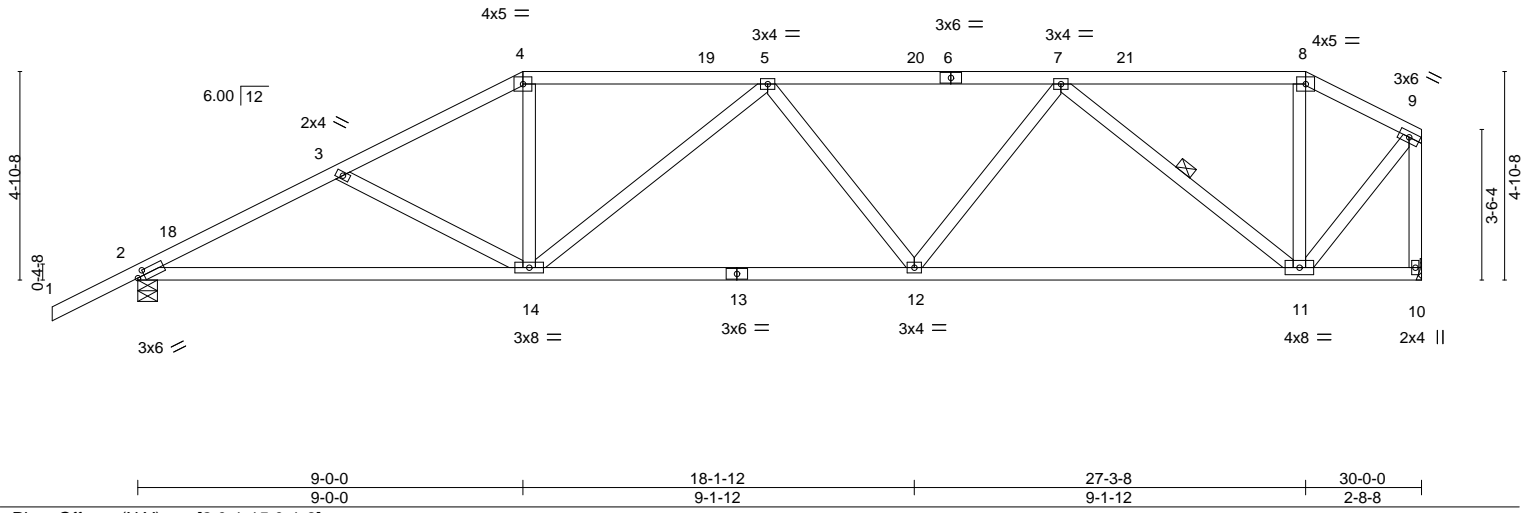

Plate Offsets (X,Y)--	[2:0-1-15,0-1-8]						
<b>LOADING</b> (psf)	<b>SPACING</b> - 2-0-0	<b>CSI.</b>	<b>DEFL.</b> in (loc)	l/defl	L/d	<b>PLATES</b>	<b>GRIP</b>
TCLL 20.0	Plate Grip DOL 1.25	TC 0.45	Vert(LL) -0.14 11-12	>999	240	MT20	244/190
TCDL 10.0	Lumber DOL 1.25	BC 0.86	Vert(CT) -0.31 11-12	>999	180		
BCLL 0.0 *	Rep Stress Incr YES	WB 0.47	Horz(CT) 0.08 10	n/a	n/a		
BCDL 10.0	Code FBC2023/TPI2014	Matrix-MS				Weight: 162 lb	FT = 20%

<b>LUMBER-</b>	<b>BRACING-</b>
TOP CHORD 2x4 SP No.2	TOP CHORD Structural wood sheathing directly applied or 3-10-7 oc purlins, except end verticals.
BOT CHORD 2x4 SP No.2	BOT CHORD Rigid ceiling directly applied or 6-0-0 oc bracing.
WEBS 2x4 SP No.3	WEBS 1 Row at midpt 7-11

**REACTIONS.** (size) 2=0-5-8, 10=Mechanical  
 Max Horz 2=179(LC 12)  
 Max Uplift 2=-365(LC 12), 10=-286(LC 8)  
 Max Grav 2=1318(LC 1), 10=1190(LC 1)

**FORCES.** (lb) - Max. Comp./Max. Ten. - All forces 250 (lb) or less except when shown.  
 TOP CHORD 2-3=-2200/586, 3-4=-1914/496, 4-5=-1673/480, 5-7=-1845/500, 7-8=-670/185, 8-9=-774/191, 9-10=-1200/280  
 BOT CHORD 2-14=-610/1921, 12-14=-555/1966, 11-12=-458/1586  
 WEBS 3-14=-300/183, 4-14=-95/561, 5-14=-465/216, 7-12=-109/473, 7-11=-1194/382, 9-11=-253/1044

- NOTES-**
- 1) Unbalanced roof live loads have been considered for this design.
  - 2) Wind: ASCE 7-22; Vult=130mph (3-second gust) Vasd=101mph; TCCL=4.2psf; BCCL=3.0psf; h=20ft; Cat. II; Exp B; Encl., GCpi=0.18; MWFRS (envelope) gable end zone and C-C Zone3 -2-0-0 to 1-0-0, Zone1 1-0-0 to 9-0-0, Zone2 9-0-0 to 13-2-15, Zone1 13-2-15 to 27-3-8, Zone3 27-3-8 to 29-10-4 zone; C-C for members and forces & MWFRS for reactions shown; Lumber DOL=1.60 plate grip DOL=1.60
  - 3) Building Designer / Project engineer responsible for verifying applied roof live load shown covers rain loading requirements specific to the use of this truss component.
  - 4) Provide adequate drainage to prevent water ponding.
  - 5) This truss has been designed for a 10.0 psf bottom chord live load nonconcurrent with any other live loads.
  - 6) \* This truss has been designed for a live load of 20.0psf on the bottom chord in all areas where a rectangle 3-6-0 tall by 2-0-0 wide will fit between the bottom chord and any other members.
  - 7) Refer to girder(s) for truss to truss connections.
  - 8) Provide mechanical connection (by others) of truss to bearing plate capable of withstanding 100 lb uplift at joint(s) except (jt=lb) 2=365, 10=286.

This item has been digitally signed and sealed by Velez, Joaquin, PE on the date indicated here. Printed copies of this document are not considered signed and sealed and the signature must be verified on any electronic copies.

Joaquin Velez PE No.68182  
 MiTek Inc. DBA MiTek USA FL Cert 6634  
 16023 Swingley Ridge Rd.  
 Chesterfield, MO 63017

Date: December 23, 2025

<p><b>WARNING - Verify design parameters and READ NOTES ON THIS AND INCLUDED MITEK REFERENCE PAGE MII-7473 rev. 1/2/2023 BEFORE USE.</b></p> <p>Design valid for use only with MiTek® connectors. This design is based only upon parameters shown, and is for an individual building component, not a truss system. Before use, the building designer must verify the applicability of design parameters and properly incorporate this design into the overall building design. Bracing indicated is to prevent buckling of individual truss web and/or chord members only. Additional temporary and permanent bracing is always required for stability and to prevent collapse with possible personal injury and property damage. For general guidance regarding the fabrication, storage, delivery, erection and bracing of trusses and truss systems, see <b>ANSI/TPI1 Quality Criteria and DSB-22</b> available from Truss Plate Institute (www.tpinst.org) and <b>BCSI Building Component Safety Information</b> available from the Structural Building Component Association (www.sbcsccomponents.com)</p>	<p>16023 Swingley Ridge Rd.          Chesterfield, MO 63017          314.434.1200 / MiTek-US.com</p>
--	--

Job 5152938	Truss T15	Truss Type Hip	Qty 1	Ply 1	THIERY RES.	T39616977
----------------	--------------	-------------------	----------	----------	-------------	-----------

Builders FirstSource (Lake City,FL), Lake City, FL - 32055,

8.830 s Sep 3 2025 MiTek Industries, Inc. Mon Dec 22 07:35:04 2025 Page 1

ID:qPB6\_vd6KiSva2ixBwiw7Vy6Vgm-6gPm7UCPDm5rWich42?UQZ99JIP18HI8GP\_KT6y6U5r

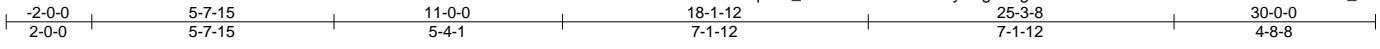

Scale = 1:53.8

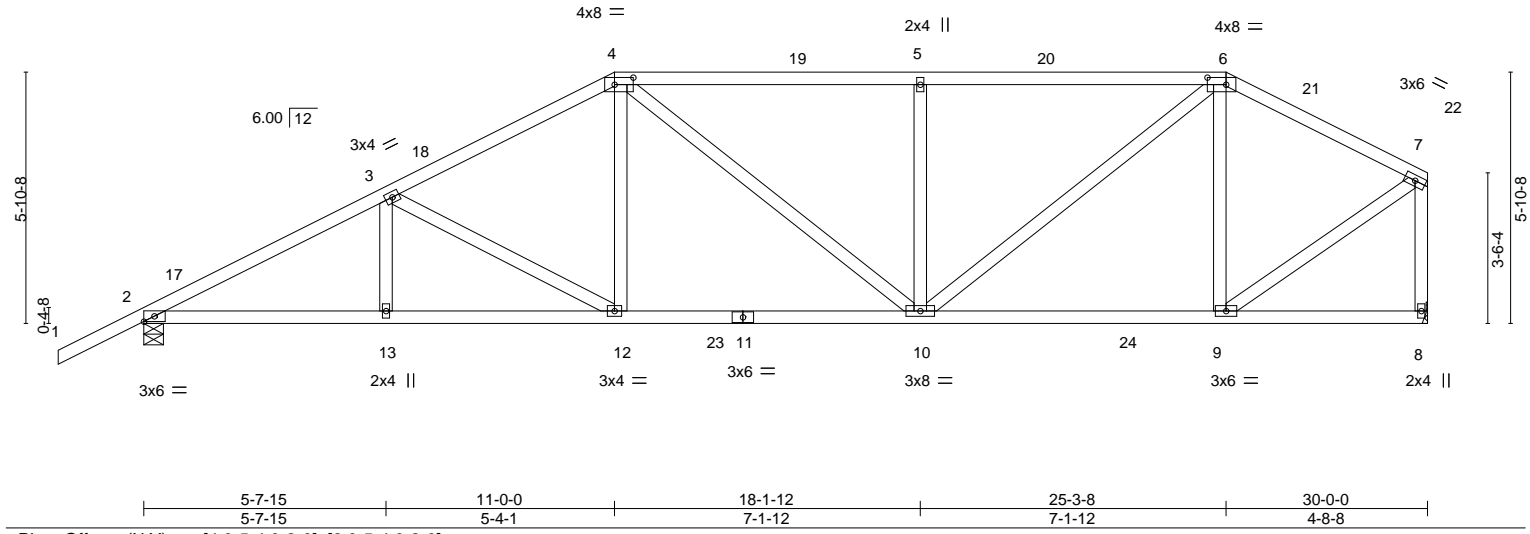

Plate Offsets (X, Y)--	[4:0-5-4,0-2-0], [6:0-5-4,0-2-0]				
<b>LOADING</b> (psf)	<b>SPACING-</b> 2-0-0	<b>CSI.</b>	<b>DEFL.</b> in (loc) l/defl L/d	<b>PLATES</b>	<b>GRIP</b>
TCLL 20.0	Plate Grip DOL 1.25	TC 0.64	Vert(LL) -0.13 10-12 >999 240	MT20	244/190
TCDL 10.0	Lumber DOL 1.25	BC 0.69	Vert(CT) -0.25 10-12 >999 180		
BCLL 0.0 *	Rep Stress Incr YES	WB 0.44	Horz(CT) 0.07 8 n/a n/a		
BCDL 10.0	Code FBC2023/TPI2014	Matrix-MS		Weight: 170 lb	FT = 20%

<b>LUMBER-</b>	<b>BRACING-</b>
TOP CHORD 2x4 SP No.2	TOP CHORD Structural wood sheathing directly applied or 3-7-6 oc purlins, except end verticals.
BOT CHORD 2x4 SP No.2	BOT CHORD Rigid ceiling directly applied or 7-8-6 oc bracing.
WEBS 2x4 SP No.3	

**REACTIONS.** (size) 2=0-5-8, 8=Mechanical  
 Max Horz 2=196(LC 12)  
 Max Uplift 2=-362(LC 12), 8=-267(LC 13)  
 Max Grav 2=1398(LC 2), 8=1305(LC 2)

**FORCES.** (lb) - Max. Comp./Max. Ten. - All forces 250 (lb) or less except when shown.  
 TOP CHORD 2-3=-2390/554, 3-4=-1907/465, 4-5=-1735/428, 5-6=-1735/428, 6-7=-1123/240, 7-8=-1246/276  
 BOT CHORD 2-13=-592/2089, 12-13=-592/2089, 10-12=-407/1662, 9-10=-186/951  
 WEBS 3-12=-511/211, 4-12=-62/493, 5-10=-494/251, 6-10=-273/1016, 6-9=-468/171, 7-9=-234/1152

- NOTES-**
- 1) Unbalanced roof live loads have been considered for this design.
  - 2) Wind: ASCE 7-22; Vult=130mph (3-second gust) Vasd=101mph; TCDL=4.2psf; BCDL=3.0psf; h=20ft; Cat. II; Exp B; Encl., GCpi=0.18; MWFRS (envelope) gable end zone and C-C Zone3 -2-0-0 to 1-0-0, Zone1 1-0-0 to 11-0-0, Zone2 11-0-0 to 15-2-15, Zone1 15-2-15 to 25-3-8, Zone2 25-3-8 to 29-6-7, Zone1 29-6-7 to 29-10-4 zone;C-C for members and forces & MWFRS for reactions shown; Lumber DOL=1.60 plate grip DOL=1.60
  - 3) Building Designer / Project engineer responsible for verifying applied roof live load shown covers rain loading requirements specific to the use of this truss component.
  - 4) Provide adequate drainage to prevent water ponding.
  - 5) This truss has been designed for a 10.0 psf bottom chord live load nonconcurrent with any other live loads.
  - 6) \* This truss has been designed for a live load of 20.0psf on the bottom chord in all areas where a rectangle 3-6-0 tall by 2-0-0 wide will fit between the bottom chord and any other members, with BCDL = 10.0psf.
  - 7) Refer to girder(s) for truss to truss connections.
  - 8) Provide mechanical connection (by others) of truss to bearing plate capable of withstanding 100 lb uplift at joint(s) except (jt=lb) 2=362, 8=267.

This item has been digitally signed and sealed by Velez, Joaquin, PE on the date indicated here. Printed copies of this document are not considered signed and sealed and the signature must be verified on any electronic copies.

Joaquin Velez PE No.68182  
 MiTek Inc. DBA MiTek USA FL Cert 6634  
 16023 Swingley Ridge Rd.  
 Chesterfield, MO 63017

Date: December 23,2025

**WARNING - Verify design parameters and READ NOTES ON THIS AND INCLUDED MITEK REFERENCE PAGE MII-7473 rev. 1/2/2023 BEFORE USE.**

Design valid for use only with MiTek® connectors. This design is based only upon parameters shown, and is for an individual building component, not a truss system. Before use, the building designer must verify the applicability of design parameters and properly incorporate this design into the overall building design. Bracing indicated is to prevent buckling of individual truss web and/or chord members only. Additional temporary and permanent bracing is always required for stability and to prevent collapse with possible personal injury and property damage. For general guidance regarding the fabrication, storage, delivery, erection and bracing of trusses and truss systems, see **ANSI/TPI1 Quality Criteria and DSB-22** available from Truss Plate Institute (www.tpinst.org) and **BCSI Building Component Safety Information** available from the Structural Building Component Association (www.sbcsccomponents.com)

**MiTek®**

16023 Swingley Ridge Rd.  
 Chesterfield, MO 63017  
 314.434.1200 / MiTek-US.com

Job 5152938	Truss T16	Truss Type Hip	Qty 1	Ply 1	THIERY RES. T39616978
----------------	--------------	-------------------	----------	----------	--------------------------

Builders FirstSource (Lake City,FL), Lake City, FL - 32055,

8.830 s Sep 3 2025 MiTek Industries, Inc. Mon Dec 22 07:35:04 2025 Page 1

ID:qPB6\_vd6KiSva2ixBwiw7Vy6Vgm-6gPm7UCPDm5rWich42?UQZ998IQo8D?8GP\_KT6y6U5r

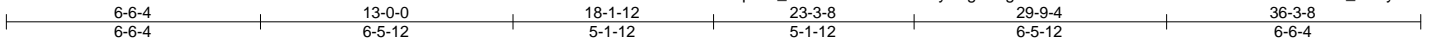

Scale = 1:59.1

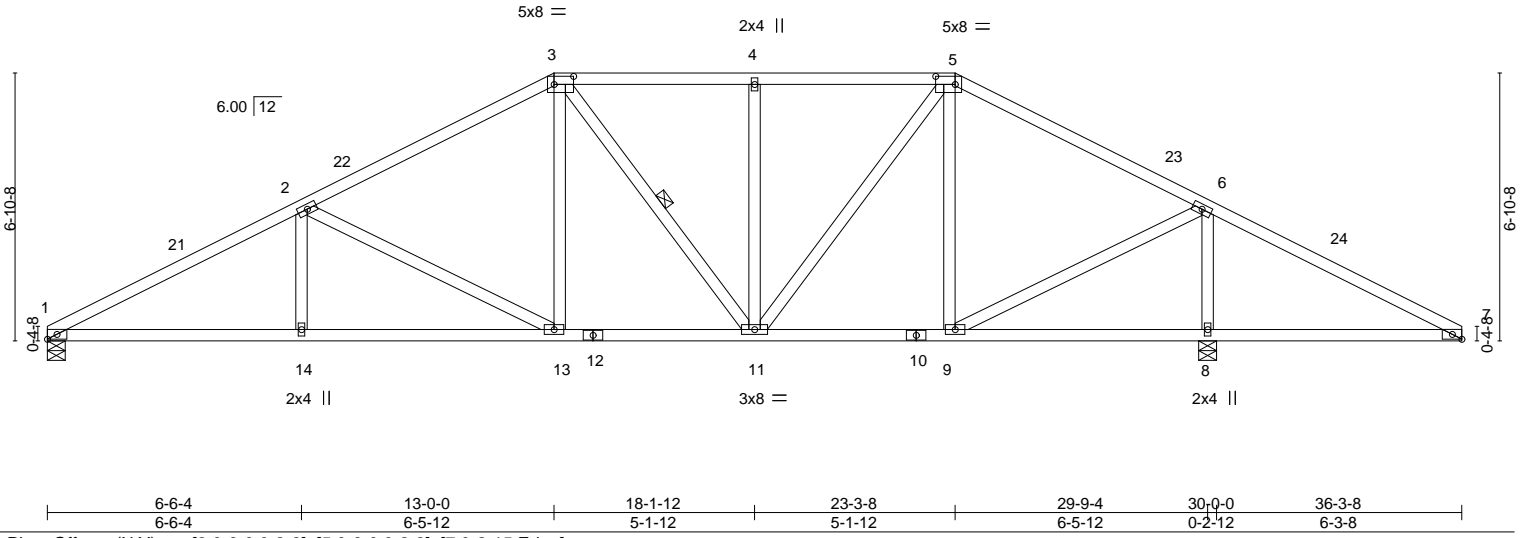

Plate Offsets (X,Y)--	[3:0-6-0,0-2-8], [5:0-6-0,0-2-8], [7:0-2-15,Edge]				
<b>LOADING</b> (psf)	<b>SPACING-</b> 2-0-0	<b>CSI.</b>	<b>DEFL.</b> in (loc) l/defl L/d	<b>PLATES</b>	<b>GRIP</b>
TCLL 20.0	Plate Grip DOL 1.25	TC 0.65	Plate(LL) -0.07 13 >999 240	MT20	244/190
TCDL 10.0	Lumber DOL 1.25	BC 0.59	Vert(CT) -0.17 13-14 >999 180		
BCLL 0.0 *	Rep Stress Incr YES	WB 0.68	Horz(CT) 0.05 8 n/a n/a		
BCDL 10.0	Code FBC2023/TPI2014	Matrix-MS			Weight: 194 lb FT = 20%

<b>LUMBER-</b>	<b>BRACING-</b>
TOP CHORD 2x4 SP No.2	TOP CHORD Structural wood sheathing directly applied or 3-7-13 oc purlins.
BOT CHORD 2x4 SP No.2	BOT CHORD Rigid ceiling directly applied or 6-0-0 oc bracing.
WEBS 2x4 SP No.3	WEBS 1 Row at midpt 3-11

**REACTIONS.** (size) 1=0-5-8, 8=0-5-8  
 Max Horz 1=-109(LC 13)  
 Max Uplift 1=-305(LC 12), 8=-431(LC 13)  
 Max Grav 1=1134(LC 25), 8=1770(LC 1)

**FORCES.** (lb) - Max. Comp./Max. Ten. - All forces 250 (lb) or less except when shown.  
 TOP CHORD 1-2=-2090/556, 2-3=-1472/421, 3-4=-1154/368, 4-5=-1154/368, 5-6=-936/250, 6-7=-260/532  
 BOT CHORD 1-14=-536/1809, 13-14=-536/1809, 11-13=-281/1237, 9-11=-99/735, 8-9=-385/268, 7-8=-385/268  
 WEBS 2-14=0/278, 2-13=-650/287, 3-13=-90/454, 4-11=-343/177, 5-11=-205/685, 5-9=-464/177, 6-9=-267/1265, 6-8=-1587/450

**NOTES-**

- Unbalanced roof live loads have been considered for this design.
- Wind: ASCE 7-22; Vult=130mph (3-second gust) Vasd=101mph; TCDL=4.2psf; BCDL=3.0psf; h=20ft; Cat. II; Exp B; Encl., GCpi=0.18; MWFRS (envelope) gable end zone and C-C Zone3 0-0-0 to 3-7-9, Zone1 3-7-9 to 13-0-0, Zone2 13-0-0 to 18-1-12, Zone1 18-1-12 to 23-3-8, Zone2 23-3-8 to 28-5-1, Zone1 28-5-1 to 36-3-8 zone; cantilever right exposed ;C-C for members and forces & MWFRS for reactions shown; Lumber DOL=1.60 plate grip DOL=1.60
- Building Designer / Project engineer responsible for verifying applied roof live load shown covers rain loading requirements specific to the use of this truss component.
- Provide adequate drainage to prevent water ponding.
- All plates are 3x6 MT20 unless otherwise indicated.
- This truss has been designed for a 10.0 psf bottom chord live load nonconcurrent with any other live loads.
- \* This truss has been designed for a live load of 20.0psf on the bottom chord in all areas where a rectangle 3-6-0 tall by 2-0-0 wide will fit between the bottom chord and any other members.
- Provide mechanical connection (by others) of truss to bearing plate capable of withstanding 100 lb uplift at joint(s) except (jt=lb) 1=305, 8=431.

This item has been digitally signed and sealed by Velez, Joaquin, PE on the date indicated here. Printed copies of this document are not considered signed and sealed and the signature must be verified on any electronic copies.

Joaquin Velez PE No.68182  
 MiTek Inc. DBA MiTek USA FL Cert 6634  
 16023 Swingley Ridge Rd.  
 Chesterfield, MO 63017

Date: December 23,2025

**WARNING - Verify design parameters and READ NOTES ON THIS AND INCLUDED MITEK REFERENCE PAGE MII-7473 rev. 1/2/2023 BEFORE USE.**

Design valid for use only with MiTek® connectors. This design is based only upon parameters shown, and is for an individual building component, not a truss system. Before use, the building designer must verify the applicability of design parameters and properly incorporate this design into the overall building design. Bracing indicated is to prevent buckling of individual truss web and/or chord members only. Additional temporary and permanent bracing is always required for stability and to prevent collapse with possible personal injury and property damage. For general guidance regarding the fabrication, storage, delivery, erection and bracing of trusses and truss systems, see **ANSI/TPI1 Quality Criteria and DSB-22** available from Truss Plate Institute (www.tpinst.org) and **BCSI Building Component Safety Information** available from the Structural Building Component Association (www.sbcsccomponents.com)

**MiTek®**  
 16023 Swingley Ridge Rd.  
 Chesterfield, MO 63017  
 314.434.1200 / MiTek-US.com

Job 5152938	Truss T17	Truss Type Hip	Qty 1	Ply 1	THIERY RES.	T39616979
----------------	--------------	-------------------	----------	----------	-------------	-----------

Builders FirstSource (Lake City,FL), Lake City, FL - 32055,

8.830 s Sep 3 2025 MiTek Industries, Inc. Mon Dec 22 07:35:05 2025 Page 1

ID:qPB6\_vd6KiSva2ixBwiv7Vy6Vgm-aty8LqD1z4Di8SBtelWjzniFsj9tjUjV3jt0Yy6U5q

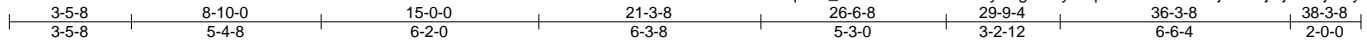

Scale = 1:65.3

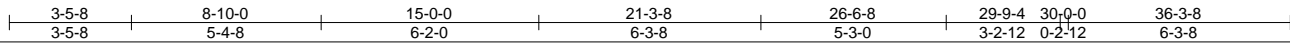
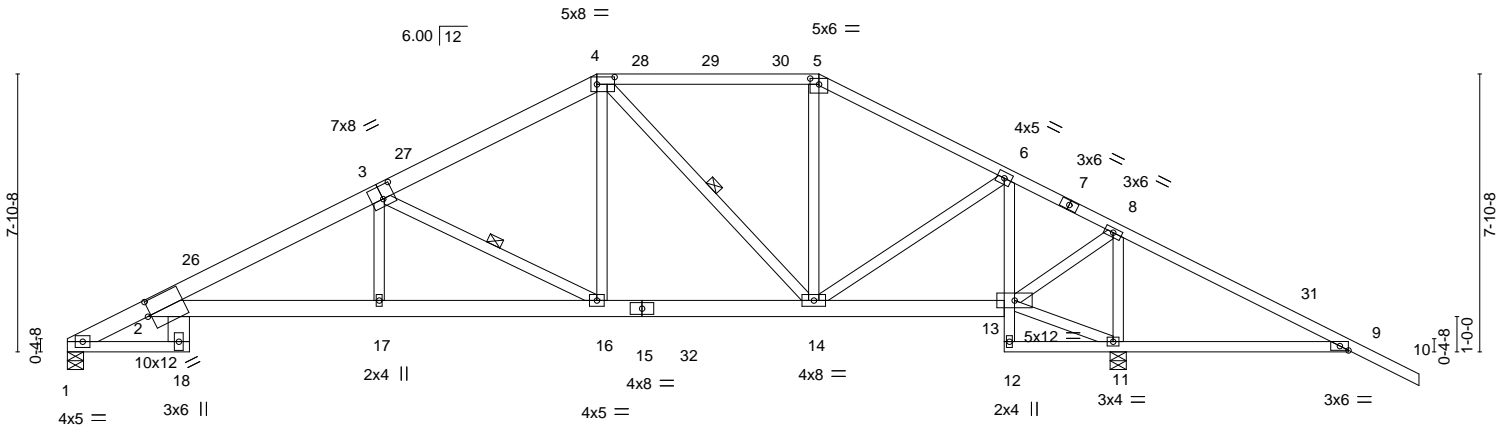

Plate Offsets (X, Y)-- [2:0-1-2,0-5-0], [3:0-4-0,0-4-8], [4:0-6-0,0-2-8], [5:0-3-0,0-2-0], [9:0-2-15,Edge]

LOADING (psf)	SPACING-	CSi.	DEFL.	PLATES	GRIP
TCLL 20.0	2-0-0	TC 0.97	in (loc) l/defl L/d	MT20	244/190
TCDL 10.0	Plate Grip DOL 1.25	BC 0.78	Vert(LL) -0.36 2-17 >996 240		
BCLL 0.0 *	Lumber DOL 1.25	WB 0.47	Vert(CT) -0.67 2-17 >531 180		
BCDL 10.0	Rep Stress Incr YES	Matrix-MS	Horz(CT) 0.36 11 n/a n/a		
	Code FBC2023/TPI2014			Weight: 231 lb	FT = 20%

LUMBER-	BRACING-
TOP CHORD 2x4 SP No.2 *Except* 3-4: 2x6 SP No.2, 1-3: 2x6 SP 2400F 2.0E or 2x6 SP M 26	TOP CHORD Structural wood sheathing directly applied.
BOT CHORD 2x4 SP No.2 *Except* 2-18: 2x8 SP 2400F 2.0E, 2-15: 2x6 SP 2400F 2.0E or 2x6 SP M 26 6-12: 2x4 SP No.3, 13-15: 2x6 SP No.2	BOT CHORD Rigid ceiling directly applied or 6-0-0 oc bracing.
WEBS 2x4 SP No.3	WEBS 1 Row at midpt 3-16, 4-14

**REACTIONS.** (size) 1=0-5-8, 11=0-5-8  
 Max Horz 1=-159(LC 13)  
 Max Uplift 1=-290(LC 12), 11=-488(LC 13)  
 Max Grav 1=1207(LC 27), 11=2017(LC 2)

**FORCES.** (lb) - Max. Comp./Max. Ten. - All forces 250 (lb) or less except when shown.

TOP CHORD	BOT CHORD	WEBS
2-22=-601/220, 2-3=-2618/659, 3-4=-1531/403, 4-5=-959/284, 5-6=-1129/294, 6-8=-546/145, 8-9=-450/859	2-17=-610/2382, 16-17=-613/2387, 14-16=-220/1297, 13-14=-22/497, 6-13=-880/341, 9-11=-688/487	3-17=-46/492, 3-16=-1255/447, 4-16=-147/751, 4-14=-488/171, 5-14=-38/261, 6-14=-256/701, 11-13=-713/492, 8-13=-180/1235, 8-11=-1507/364

- NOTES-**
- Unbalanced roof live loads have been considered for this design.
  - Wind: ASCE 7-22; Vult=130mph (3-second gust) Vasd=101mph; TCDL=4.2psf; BCDL=3.0psf; h=20ft; Cat. II; Exp B; Encl., GCpi=0.18; MWFRS (envelope) gable end zone and C-C Zone3 0-2-12 to 3-10-5, Zone1 3-10-5 to 15-0-0, Zone2 15-0-0 to 20-1-9, Zone1 20-1-9 to 21-3-8, Zone2 21-3-8 to 26-8-4, Zone1 26-8-4 to 38-3-8 zone; cantilever right exposed ;C-C for members and forces & MWFRS for reactions shown; Lumber DOL=1.60 plate grip DOL=1.60
  - Building Designer / Project engineer responsible for verifying applied roof live load shown covers rain loading requirements specific to the use of this truss component.
  - Provide adequate drainage to prevent water ponding.
  - This truss has been designed for a 10.0 psf bottom chord live load nonconcurrent with any other live loads.
  - \* This truss has been designed for a live load of 20.0psf on the bottom chord in all areas where a rectangle 3-6-0 tall by 2-0-0 wide will fit between the bottom chord and any other members, with BCDL = 10.0psf.
  - Provide mechanical connection (by others) of truss to bearing plate capable of withstanding 100 lb uplift at joint(s) except (jt=lb) 1=290, 11=488.

This item has been digitally signed and sealed by Velez, Joaquin, PE on the date indicated here. Printed copies of this document are not considered signed and sealed and the signature must be verified on any electronic copies.

Joaquin Velez PE No.68182  
 MiTek Inc. DBA MiTek USA FL Cert 6634  
 16023 Swingley Ridge Rd.  
 Chesterfield, MO 63017  
 Date:

December 23,2025

<p><b>WARNING - Verify design parameters and READ NOTES ON THIS AND INCLUDED MITEK REFERENCE PAGE MII-7473 rev. 1/2/2023 BEFORE USE.</b></p> <p>Design valid for use only with MiTek® connectors. This design is based only upon parameters shown, and is for an individual building component, not a truss system. Before use, the building designer must verify the applicability of design parameters and properly incorporate this design into the overall building design. Bracing indicated is to prevent buckling of individual truss web and/or chord members only. Additional temporary and permanent bracing is always required for stability and to prevent collapse with possible personal injury and property damage. For general guidance regarding the fabrication, storage, delivery, erection and bracing of trusses and truss systems, see <b>ANSI/TPI1 Quality Criteria and DSB-22</b> available from Truss Plate Institute (www.tpinst.org) and <b>BCSI Building Component Safety Information</b> available from the Structural Building Component Association (www.sbcsccomponents.com)</p>	<p>16023 Swingley Ridge Rd.        Chesterfield, MO 63017        314.434.1200 / MiTek-US.com</p>
--	--

Job 5152938	Truss T18	Truss Type Hip	Qty 1	Ply 1	THIERY RES. T39616980
----------------	--------------	-------------------	----------	----------	--------------------------

Builders FirstSource (Lake City,FL), Lake City, FL - 32055,

8.830 s Sep 3 2025 MiTek Industries, Inc. Mon Dec 22 07:35:06 2025 Page 1

ID:qPB6\_vd6KiSva2ixBwiw7Vy6Vgm-23WXY9EfkOLZmcm3CT2yV\_FSu66lc3MRkjTQY?y6U5p

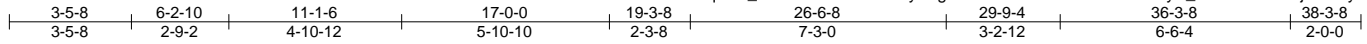

Scale = 1:65.3

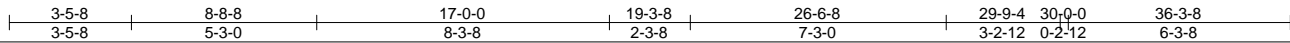
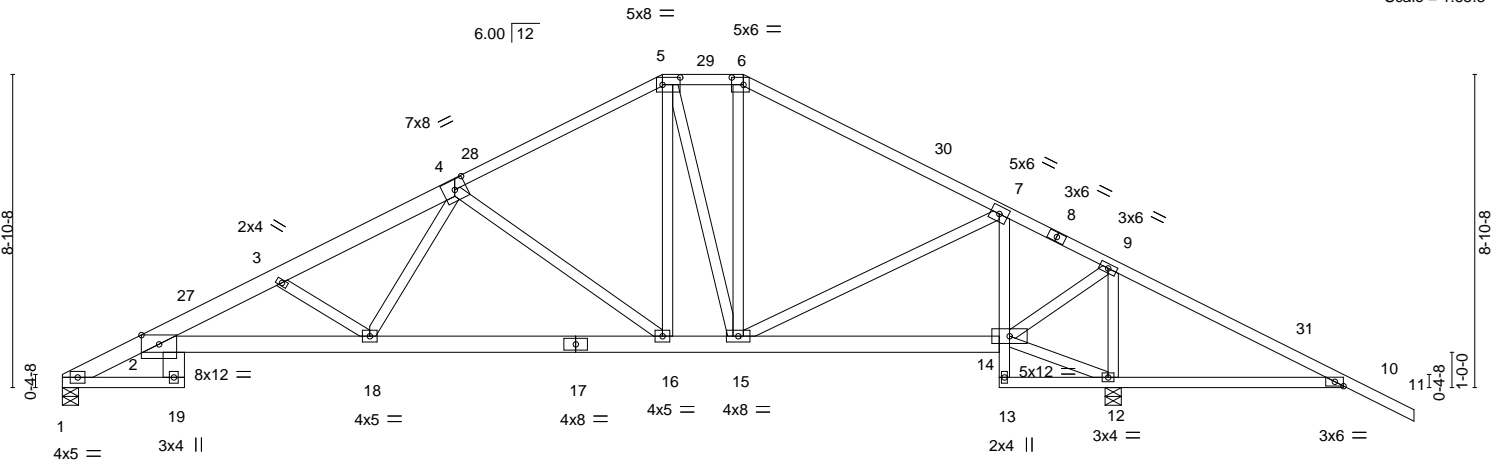

<b>LOADING</b> (psf)	<b>SPACING-</b>	2-0-0	<b>CSI.</b>	<b>DEFL.</b>	in (loc)	l/defl	L/d	<b>PLATES</b>	<b>GRIP</b>
TCLL 20.0	Plate Grip DOL	1.25	TC 0.89	Vert(LL)	-0.25	2-18	>999	MT20	244/190
TCDL 10.0	Lumber DOL	1.25	BC 0.62	Vert(CT)	-0.52	2-18	>693		
BCLL 0.0 *	Rep Stress Incr	YES	WB 0.94	Horz(CT)	0.28	12	n/a		
BCDL 10.0	Code	FBC2023/TPI2014	Matrix-MS						
								Weight: 240 lb	FT = 20%

<b>LUMBER-</b>	<b>BRACING-</b>
TOP CHORD 2x4 SP No.2 *Except* 1-4: 2x6 SP 2400F 2.0E or 2x6 SP M 26	TOP CHORD Structural wood sheathing directly applied or 2-2-0 oc purlins.
BOT CHORD 2x4 SP No.2 *Except* 2-19: 2x8 SP 2400F 2.0E, 2-17: 2x6 SP 2400F 2.0E or 2x6 SP M 26 7-13: 2x4 SP No.3, 14-17: 2x6 SP No.2	BOT CHORD Rigid ceiling directly applied or 6-0-0 oc bracing.
WEBS 2x4 SP No.3	

<b>REACTIONS.</b>	(size) 1=0-5-8, 12=0-5-8 Max Horz 1=-176(LC 13) Max Uplift 1=-285(LC 12), 12=-484(LC 13) Max Grav 1=1106(LC 1), 12=1912(LC 1)
-------------------	--

<b>FORCES.</b> (lb) - Max. Comp./Max. Ten. - All forces 250 (lb) or less except when shown.
TOP CHORD 2-23=-558/236, 2-3=-2868/804, 3-4=-2371/657, 4-5=-1145/343, 5-6=-879/314, 6-7=-1089/322, 7-9=-482/151, 9-10=-451/863
BOT CHORD 2-18=-826/2738, 16-18=-440/1635, 15-16=-147/954, 14-15=-38/416, 7-14=-886/356, 10-12=-693/489
WEBS 3-18=-855/349, 4-18=-212/861, 4-16=-867/371, 5-16=-166/539, 5-15=-330/130, 6-15=-75/277, 7-15=-235/592, 12-14=-720/508, 9-14=-185/1203, 9-12=-1470/351

- NOTES-**
- Unbalanced roof live loads have been considered for this design.
  - Wind: ASCE 7-22; Vult=130mph (3-second gust) Vasd=101mph; TCCL=4.2psf; BCDL=3.0psf; h=20ft; Cat. II; Exp B; Encl., GCpi=0.18; MWFRS (envelope) gable end zone and C-C Zone3 0-2-12 to 3-10-5, Zone1 3-10-5 to 17-0-0, Zone3 17-0-0 to 19-3-8, Zone2 19-3-8 to 24-5-1, Zone1 24-5-1 to 38-3-8 zone; cantilever right exposed ;C-C for members and forces & MWFRS for reactions shown; Lumber DOL=1.60 plate grip DOL=1.60
  - Building Designer / Project engineer responsible for verifying applied roof live load shown covers rain loading requirements specific to the use of this truss component.
  - Provide adequate drainage to prevent water ponding.
  - This truss has been designed for a 10.0 psf bottom chord live load nonconcurrent with any other live loads.
  - \* This truss has been designed for a live load of 20.0psf on the bottom chord in all areas where a rectangle 3-6-0 tall by 2-0-0 wide will fit between the bottom chord and any other members.
  - Provide mechanical connection (by others) of truss to bearing plate capable of withstanding 100 lb uplift at joint(s) except (jt=lb) 1=285, 12=484.

This item has been digitally signed and sealed by Velez, Joaquin, PE on the date indicated here. Printed copies of this document are not considered signed and sealed and the signature must be verified on any electronic copies.

Joaquin Velez PE No.68182  
MiTek Inc. DBA MiTek USA FL Cert 6634  
16023 Swingley Ridge Rd.  
Chesterfield, MO 63017  
Date:

December 23,2025

<p><b>WARNING - Verify design parameters and READ NOTES ON THIS AND INCLUDED MITEK REFERENCE PAGE MII-7473 rev. 1/2/2023 BEFORE USE.</b></p> <p>Design valid for use only with MiTek® connectors. This design is based only upon parameters shown, and is for an individual building component, not a truss system. Before use, the building designer must verify the applicability of design parameters and properly incorporate this design into the overall building design. Bracing indicated is to prevent buckling of individual truss web and/or chord members only. Additional temporary and permanent bracing is always required for stability and to prevent collapse with possible personal injury and property damage. For general guidance regarding the fabrication, storage, delivery, erection and bracing of trusses and truss systems, see <b>ANSI/TPI1 Quality Criteria and DSB-22</b> available from Truss Plate Institute (www.tpinst.org) and <b>BCSI Building Component Safety Information</b> available from the Structural Building Component Association (www.sbcsccomponents.com)</p>	 <p>16023 Swingley Ridge Rd. Chesterfield, MO 63017 314.434.1200 / MiTek-US.com</p>
--	--

Job 5152938	Truss T19	Truss Type Hip Girder	Qty 1	Ply 1	THIERI RES. Job Reference (optional)	T39616981
----------------	--------------	--------------------------	----------	----------	---	-----------

Builders FirstSource (Lake City,FL), Lake City, FL - 32055,

8.830 s Sep 3 2025 MiTek Industries, Inc. Mon Dec 22 07:35:06 2025 Page 1

ID:qPB6\_vd6KiSva2ixBwiw7Vy6Vgm-23WXY9EfKOLZmcm3CT2yV\_FXT67ucDxRkjTQY?y6U5p

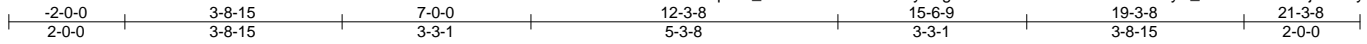

Scale = 1:39.7

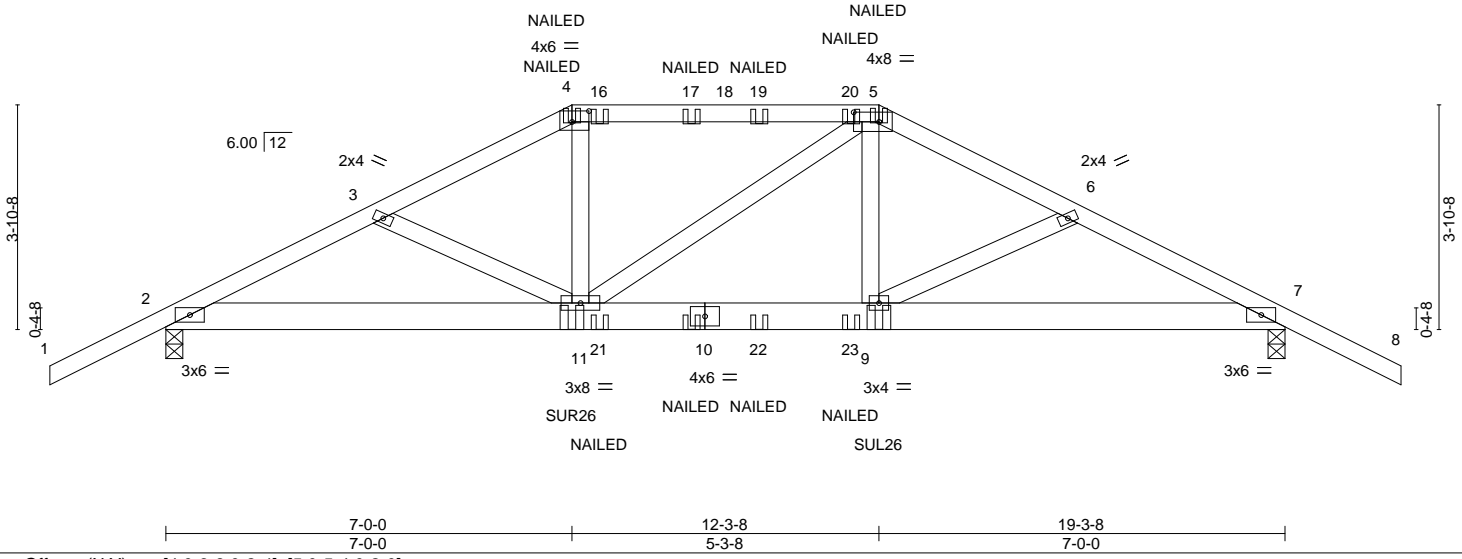

Plate Offsets (X,Y)--	[4:0-3-8,0-2-4], [5:0-5-4,0-2-0]				
<b>LOADING</b> (psf)	<b>SPACING-</b> 2-0-0	<b>CSI.</b>	<b>DEFL.</b> in (loc) l/defl L/d	<b>PLATES</b>	<b>GRIP</b>
TCLL 20.0	Plate Grip DOL 1.25	TC 0.54	Vert(LL) 0.12 9-11 >999 240	MT20	244/190
TCDL 10.0	Lumber DOL 1.25	BC 0.55	Vert(CT) -0.17 9-11 >999 180		
BCLL 0.0 *	Rep Stress Incr NO	WB 0.27	Horz(CT) 0.05 7 n/a n/a		
BCDL 10.0	Code FBC2023/TPI2014	Matrix-MS		Weight: 112 lb	FT = 20%

<b>LUMBER-</b>	<b>BRACING-</b>
TOP CHORD 2x4 SP No.2 *Except* 4-5: 2x4 SP 2700F 2.2E or 2x4 SP 2850F 2.0E or 2x4 SP M 31	TOP CHORD Structural wood sheathing directly applied or 3-4-5 oc purlins. BOT CHORD Rigid ceiling directly applied or 6-6-3 oc bracing.
BOT CHORD 2x6 SP No.2	
WEBS 2x4 SP No.3	

<b>REACTIONS.</b>	(size) 2=0-3-8, 7=0-3-8
	Max Horz 2=75(LC 33)
	Max Uplift 2=730(LC 8), 7=731(LC 9)
	Max Grav 2=1567(LC 1), 7=1568(LC 1)

<b>FORCES.</b>	(lb) - Max. Comp./Max. Ten. - All forces 250 (lb) or less except when shown.
TOP CHORD	2-3=-2832/1431, 3-4=-2657/1419, 4-5=-2381/1306, 5-6=-2659/1421, 6-7=-2835/1433
BOT CHORD	2-11=-1266/2494, 9-11=-1215/2383, 7-9=-1231/2497
WEBS	4-11=-313/693, 5-9=-333/697

- NOTES-**
- 1) Unbalanced roof live loads have been considered for this design.
  - 2) Wind: ASCE 7-22; Vult=130mph (3-second gust) Vasd=101mph; TCDL=4.2psf; BCDL=3.0psf; h=20ft; Cat. II; Exp B; Encl., GCpi=0.18; MWFRS (envelope) gable end zone; porch left and right exposed; Lumber DOL=1.60 plate grip DOL=1.60
  - 3) Building Designer / Project engineer responsible for verifying applied roof live load shown covers rain loading requirements specific to the use of this truss component.
  - 4) Provide adequate drainage to prevent water ponding.
  - 5) This truss has been designed for a 10.0 psf bottom chord live load nonconcurrent with any other live loads.
  - 6) \* This truss has been designed for a live load of 20.0psf on the bottom chord in all areas where a rectangle 3-6-0 tall by 2-0-0 wide will fit between the bottom chord and any other members.
  - 7) Provide mechanical connection (by others) of truss to bearing plate capable of withstanding 100 lb uplift at joint(s) except (jt=lb) 2=730, 7=731.
  - 8) Use Simpson Strong-Tie SUR26 (6-10dx1 1/2 Girder, 6-10dx1 1/2 Truss, Single Ply Girder) or equivalent at 7-0-0 from the left end to connect truss(es) to back face of bottom chord, skewed 45.0 deg.to the right, sloping 0.0 deg. down.
  - 9) Use Simpson Strong-Tie SUL26 (6-16d Girder, 6-10dx1 1/2 Truss) or equivalent at 12-3-8 from the left end to connect truss(es) to back face of bottom chord, skewed 45.0 deg.to the left, sloping 0.0 deg. down.
  - 10) Fill all nail holes where hanger is in contact with lumber.
  - 11) "NAILED" indicates 3-10d (0.148"x3") or 2-12d (0.148"x3.25") toe-nails per NDS guidelines.
  - 12) In the LOAD CASE(S) section, loads applied to the face of the truss are noted as front (F) or back (B).

<b>LOAD CASE(S)</b> Standard
1) Dead + Roof Live (balanced): Lumber Increase=1.25, Plate Increase=1.25
Uniform Loads (plf)
Vert: 1-4=-60, 4-5=-60, 5-8=-60, 2-7=-20

This item has been digitally signed and sealed by Velez, Joaquin, PE on the date indicated here. Printed copies of this document are not considered signed and sealed and the signature must be verified on any electronic copies.

Joaquin Velez PE No.68182  
MiTek Inc. DBA MiTek USA FL Cert 6634  
16023 Swingley Ridge Rd.  
Chesterfield, MO 63017  
Date:

December 23,2025

Continued on page 2

<p><b>WARNING - Verify design parameters and READ NOTES ON THIS AND INCLUDED MITEK REFERENCE PAGE MII-7473 rev. 1/2/2023 BEFORE USE.</b></p> <p>Design valid for use only with MiTek® connectors. This design is based only upon parameters shown, and is for an individual building component, not a truss system. Before use, the building designer must verify the applicability of design parameters and properly incorporate this design into the overall building design. Bracing indicated is to prevent buckling of individual truss web and/or chord members only. Additional temporary and permanent bracing is always required for stability and to prevent collapse with possible personal injury and property damage. For general guidance regarding the fabrication, storage, delivery, erection and bracing of trusses and truss systems, see <b>ANSI/TPI1 Quality Criteria and DSB-22</b> available from Truss Plate Institute (www.tpinst.org) and <b>BCSI Building Component Safety Information</b> available from the Structural Building Component Association (www.sbcsccomponents.com)</p>	<p>16023 Swingley Ridge Rd. Chesterfield, MO 63017 314.434.1200 / MiTek-US.com</p>
--	--

Job 5152938	Truss T19	Truss Type Hip Girder	Qty 1	Ply 1	THIERY RES.  Job Reference (optional)	T39616981
----------------	--------------	--------------------------	----------	----------	---	-----------

Builders FirstSource (Lake City,FL), Lake City, FL - 32055,

8.830 s Sep 3 2025 MiTek Industries, Inc. Mon Dec 22 07:35:07 2025 Page 2  
ID:qPB6\_vd6KiSva2ixBwiw7Vy6Vgm-WF4vmVEHVhTQNmLgMAZB2CniCVT7LgBbyNC\_4Ry6U5o

**LOAD CASE(S)** Standard

Concentrated Loads (lb)

Vert: 4=-76(B) 5=-76(B) 10=-63(B) 11=-239(B) 9=-239(B) 16=-117(B) 17=-117(B) 19=-117(B) 20=-117(B) 21=-63(B) 22=-63(B) 23=-63(B)

**WARNING - Verify design parameters and READ NOTES ON THIS AND INCLUDED MITEK REFERENCE PAGE MII-7473 rev. 1/2/2023 BEFORE USE.**

Design valid for use only with MiTek® connectors. This design is based only upon parameters shown, and is for an individual building component, not a truss system. Before use, the building designer must verify the applicability of design parameters and properly incorporate this design into the overall building design. Bracing indicated is to prevent buckling of individual truss web and/or chord members only. Additional temporary and permanent bracing is always required for stability and to prevent collapse with possible personal injury and property damage. For general guidance regarding the fabrication, storage, delivery, erection and bracing of trusses and truss systems, see **ANSI/TPI1 Quality Criteria and DSB-22** available from Truss Plate Institute ([www.tpinst.org](http://www.tpinst.org)) and **BCSI Building Component Safety Information** available from the Structural Building Component Association ([www.sbcsccomponents.com](http://www.sbcsccomponents.com))

**MiTek®**

16023 Swingley Ridge Rd.  
Chesterfield, MO 63017  
314.434.1200 / MiTek-US.com

Job 5152938	Truss T20	Truss Type Hip	Qty 1	Ply 1	THIERY RES. T39616982
----------------	--------------	-------------------	----------	----------	--------------------------

Builders FirstSource (Lake City,FL), Lake City, FL - 32055,

8.830 s Sep 3 2025 MiTek Industries, Inc. Mon Dec 22 07:35:07 2025 Page 1

ID:qPB6\_vd6KiSva2ixBwiw7Vy6Vgm-WF4vmVEHVhTQNmLgMAZB2Cnk\_VQ6LiPbyNC\_4Ry6U5o

Job Reference (optional)

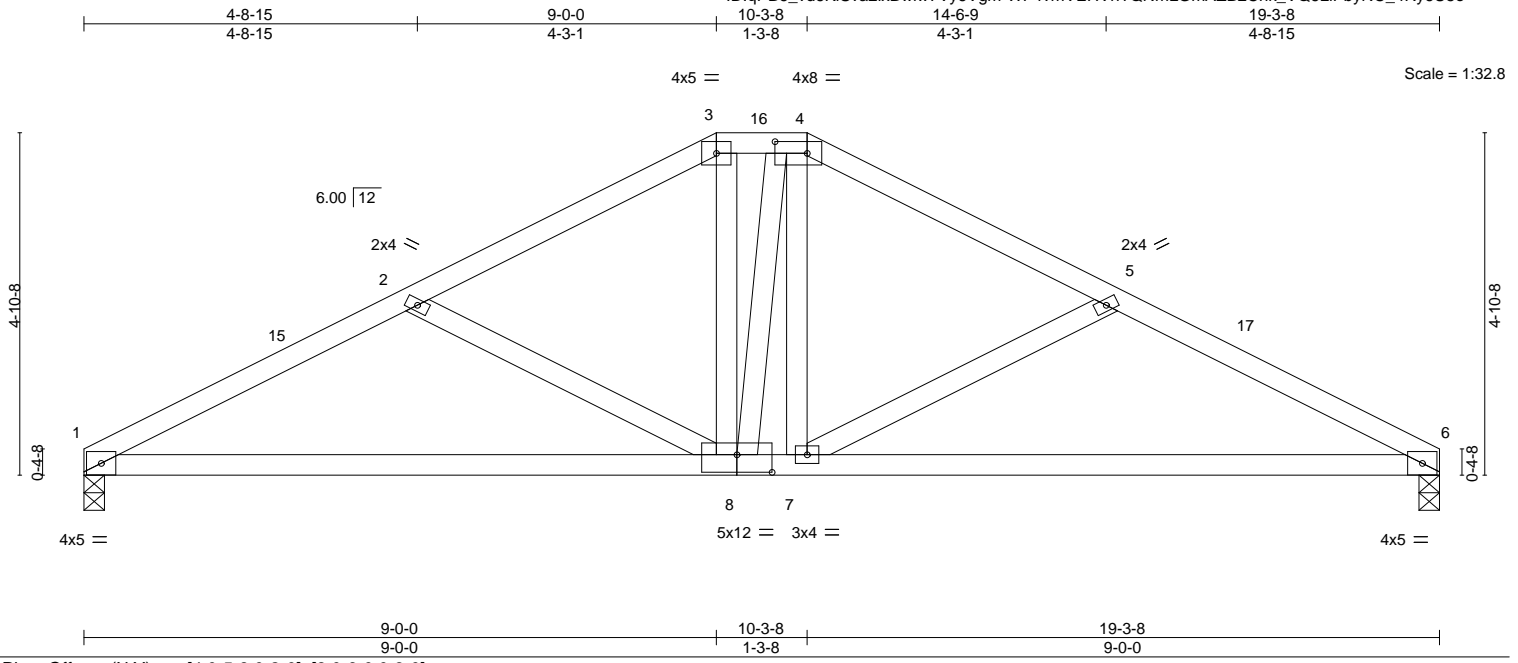

Plate Offsets (X, Y)--	[4:0-5-8,0-2-0], [8:0-6-0,0-3-0]				
<b>LOADING</b> (psf)	<b>SPACING-</b> 2-0-0	<b>CSI.</b>	<b>DEFL.</b> in (loc) l/defl L/d	<b>PLATES</b>	<b>GRIP</b>
TCLL 20.0	Plate Grip DOL 1.25	TC 0.42	Vert(LL) 0.15 8-11 >999 240	MT20	244/190
TCDL 10.0	Lumber DOL 1.25	BC 0.74	Vert(CT) -0.29 8-11 >809 180		
BCLL 0.0 *	Rep Stress Incr YES	WB 0.19	Horz(CT) 0.03 6 n/a n/a		
BCDL 10.0	Code FBC2023/TPI2014	Matrix-MS		Weight: 95 lb	FT = 20%

<b>LUMBER-</b>	<b>BRACING-</b>
TOP CHORD 2x4 SP No.2	TOP CHORD Structural wood sheathing directly applied or 4-9-8 oc purlins.
BOT CHORD 2x4 SP No.2	BOT CHORD Rigid ceiling directly applied or 8-0-10 oc bracing.
WEBS 2x4 SP No.3	

**REACTIONS.** (size) 1=0-3-8, 6=0-3-8  
 Max Horz 1=-75(LC 13)  
 Max Uplift 1=-244(LC 9), 6=-244(LC 8)  
 Max Grav 1=772(LC 1), 6=772(LC 1)

**FORCES.** (lb) - Max. Comp./Max. Ten. - All forces 250 (lb) or less except when shown.  
 TOP CHORD 1-2=-1318/587, 2-3=-1001/494, 3-4=-849/471, 4-5=-1006/497, 5-6=-1319/588  
 BOT CHORD 1-8=-502/1158, 7-8=-337/844, 6-7=-498/1159  
 WEBS 2-8=-369/210, 3-8=-177/286, 4-7=-160/268, 5-7=-367/209

- NOTES-**
- Unbalanced roof live loads have been considered for this design.
  - Wind: ASCE 7-22; Vult=130mph (3-second gust) Vasd=101mph; TC DL=4.2psf; BCDL=3.0psf; h=20ft; Cat. II; Exp B; Encl., GCpi=0.18; MWFRS (envelope) gable end zone and C-C Zone3 0-0-0 to 3-0-0, Zone1 3-0-0 to 9-0-0, Zone3 9-0-0 to 10-3-8, Zone2 10-3-8 to 14-8-8, Zone1 14-8-8 to 19-3-8 zone; porch left and right exposed; C-C for members and forces & MWFRS for reactions shown; Lumber DOL=1.60 plate grip DOL=1.60
  - Building Designer / Project engineer responsible for verifying applied roof live load shown covers rain loading requirements specific to the use of this truss component.
  - Provide adequate drainage to prevent water ponding.
  - This truss has been designed for a 10.0 psf bottom chord live load nonconcurrent with any other live loads.
  - \* This truss has been designed for a live load of 20.0psf on the bottom chord in all areas where a rectangle 3-6-0 tall by 2-0-0 wide will fit between the bottom chord and any other members.
  - Provide mechanical connection (by others) of truss to bearing plate capable of withstanding 100 lb uplift at joint(s) except (jt=lb) 1=244, 6=244.

This item has been digitally signed and sealed by Velez, Joaquin, PE on the date indicated here. Printed copies of this document are not considered signed and sealed and the signature must be verified on any electronic copies.

Joaquin Velez PE No.68182  
 MiTek Inc. DBA MiTek USA FL Cert 6634  
 16023 Swingley Ridge Rd.  
 Chesterfield, MO 63017  
 Date:

December 23,2025

<p><b>WARNING - Verify design parameters and READ NOTES ON THIS AND INCLUDED MITEK REFERENCE PAGE MII-7473 rev. 1/2/2023 BEFORE USE.</b></p> <p>Design valid for use only with MiTek® connectors. This design is based only upon parameters shown, and is for an individual building component, not a truss system. Before use, the building designer must verify the applicability of design parameters and properly incorporate this design into the overall building design. Bracing indicated is to prevent buckling of individual truss web and/or chord members only. Additional temporary and permanent bracing is always required for stability and to prevent collapse with possible personal injury and property damage. For general guidance regarding the fabrication, storage, delivery, erection and bracing of trusses and truss systems, see <b>ANSI/TPI1 Quality Criteria and DSB-22</b> available from Truss Plate Institute (www.tpinst.org) and <b>BCSI Building Component Safety Information</b> available from the Structural Building Component Association (www.sbcsccomponents.com)</p>	 <p>16023 Swingley Ridge Rd.        Chesterfield, MO 63017        314.434.1200 / MiTek-US.com</p>
--	--

Job 5152938	Truss T21	Truss Type Common	Qty 3	Ply 1	THIERY RES. T39616983
----------------	--------------	----------------------	----------	----------	--------------------------

Builders FirstSource (Lake City,FL), Lake City, FL - 32055,

8.830 s Sep 3 2025 MiTek Industries, Inc. Mon Dec 22 07:35:07 2025 Page 1

ID:qPB6\_vd6KiSva2ixBwiw7Vy6Vgm-WF4vmVEHVhTQNmLGmAZB2CniWVUNLjXbyNC\_4Ry6U5o

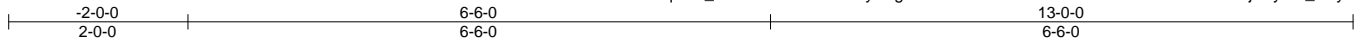

Scale = 1:25.7

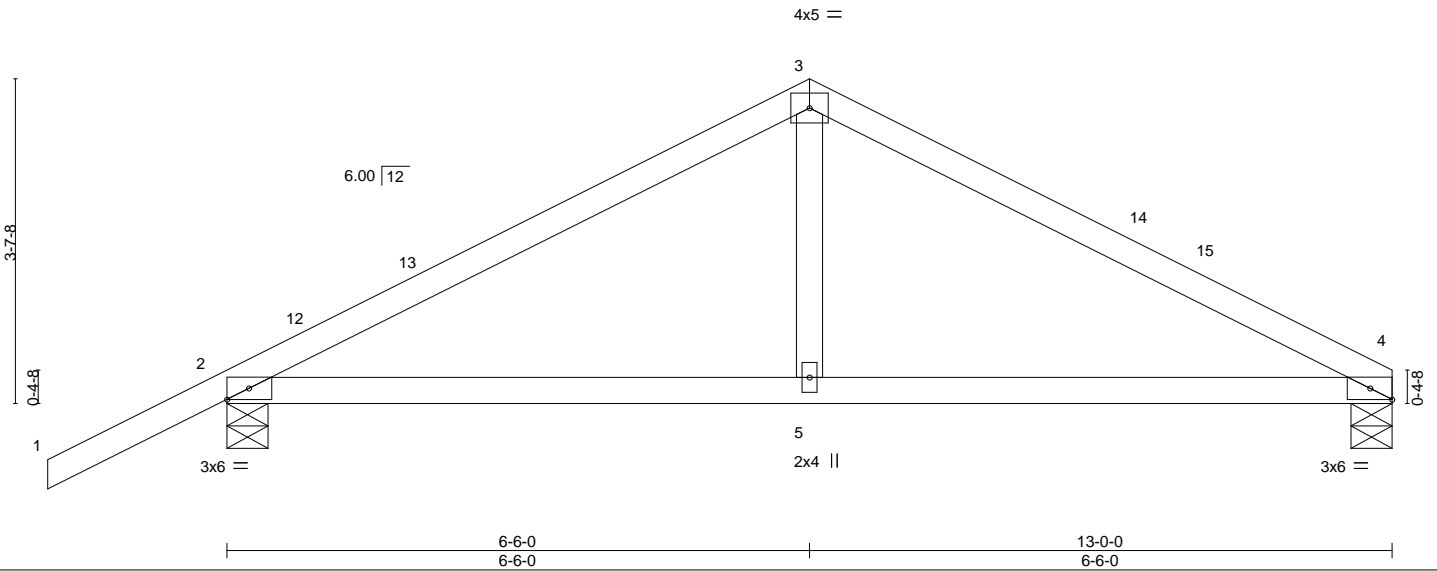

Plate Offsets (X,Y)--	[4:0-2-15,Edge]									
<b>LOADING</b> (psf)	<b>SPACING-</b>	2-0-0	<b>CSI.</b>	<b>DEFL.</b>	in	(loc)	l/defl	L/d	<b>PLATES</b>	<b>GRIP</b>
TCLL 20.0	Plate Grip DOL	1.25	TC 0.52	Vert(LL)	0.07	5-8	>999	240	MT20	244/190
TCDL 10.0	Lumber DOL	1.25	BC 0.47	Vert(CT)	-0.12	5-8	>999	180		
BCLL 0.0 *	Rep Stress Incr	YES	WB 0.12	Horz(CT)	0.01	4	n/a	n/a		
BCDL 10.0	Code	FBC2023/TPI2014	Matrix-MS						Weight: 49 lb	FT = 20%

<b>LUMBER-</b>		<b>BRACING-</b>	
TOP CHORD	2x4 SP No.2	TOP CHORD	Structural wood sheathing directly applied or 6-0-0 oc purlins.
BOT CHORD	2x4 SP No.2	BOT CHORD	Rigid ceiling directly applied or 10-0-0 oc bracing.
WEBS	2x4 SP No.3		

**REACTIONS.** (size) 4=0-5-8, 2=0-5-8  
 Max Horz 2=87(LC 12)  
 Max Uplift 4=-121(LC 13), 2=-177(LC 12)  
 Max Grav 4=511(LC 1), 2=649(LC 1)

**FORCES.** (lb) - Max. Comp./Max. Ten. - All forces 250 (lb) or less except when shown.  
 TOP CHORD 2-3=-722/243, 3-4=-718/253  
 BOT CHORD 2-5=-133/574, 4-5=-133/574  
 WEBS 3-5=-12/302

**NOTES-**

- Unbalanced roof live loads have been considered for this design.
- Wind: ASCE 7-22; Vult=130mph (3-second gust) Vasd=101mph; TC DL=4.2psf; BCDL=3.0psf; h=20ft; Cat. II; Exp B; Encl., GCpi=0.18; MWFRS (envelope) gable end zone and C-C Zone3 -2-0-0 to 1-0-0, Zone1 1-0-0 to 6-6-0, Zone2 6-6-0 to 10-8-15, Zone1 10-8-15 to 13-0-0 zone;C-C for members and forces & MWFRS for reactions shown; Lumber DOL=1.60 plate grip DOL=1.60
- Building Designer / Project engineer responsible for verifying applied roof live load shown covers rain loading requirements specific to the use of this truss component.
- This truss has been designed for a 10.0 psf bottom chord live load nonconcurrent with any other live loads.
- \* This truss has been designed for a live load of 20.0psf on the bottom chord in all areas where a rectangle 3-6-0 tall by 2-0-0 wide will fit between the bottom chord and any other members.
- Provide mechanical connection (by others) of truss to bearing plate capable of withstanding 100 lb uplift at joint(s) except (jt=lb) 4=121, 2=177.

This item has been digitally signed and sealed by Velez, Joaquin, PE on the date indicated here. Printed copies of this document are not considered signed and sealed and the signature must be verified on any electronic copies.

Joaquin Velez PE No.68182  
 MiTek Inc. DBA MiTek USA FL Cert 6634  
 16023 Swingley Ridge Rd.  
 Chesterfield, MO 63017

Date: December 23,2025

<p><b>WARNING - Verify design parameters and READ NOTES ON THIS AND INCLUDED MITEK REFERENCE PAGE MII-7473 rev. 1/2/2023 BEFORE USE.</b></p> <p>Design valid for use only with MiTek® connectors. This design is based only upon parameters shown, and is for an individual building component, not a truss system. Before use, the building designer must verify the applicability of design parameters and properly incorporate this design into the overall building design. Bracing indicated is to prevent buckling of individual truss web and/or chord members only. Additional temporary and permanent bracing is always required for stability and to prevent collapse with possible personal injury and property damage. For general guidance regarding the fabrication, storage, delivery, erection and bracing of trusses and truss systems, see <b>ANSI/TPI1 Quality Criteria and DSB-22</b> available from Truss Plate Institute (www.tpinst.org) and <b>BCSI Building Component Safety Information</b> available from the Structural Building Component Association (www.sbcsccomponents.com)</p>	 <p>16023 Swingley Ridge Rd.          Chesterfield, MO 63017          314.434.1200 / MiTek-US.com</p>
--	--

Job 5152938	Truss T21G	Truss Type Common Supported Gable	Qty 1	Ply 1	THIERY RES. Job Reference (optional)	T39616984
----------------	---------------	--------------------------------------	----------	----------	---	-----------

Builders FirstSource (Lake City,FL), Lake City, FL - 32055,

8.830 s Sep 3 2025 MiTek Industries, Inc. Mon Dec 22 07:35:08 2025 Page 1

ID:qPB6\_vd6KiSva2ixBwiw7Vy6Vgm-\_SeHzrFvG?bH?wwSJU4QaPKx0vxL4AzkB1yXcty6U5n

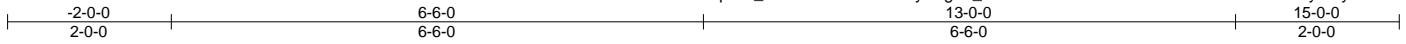

Scale = 1:28.1

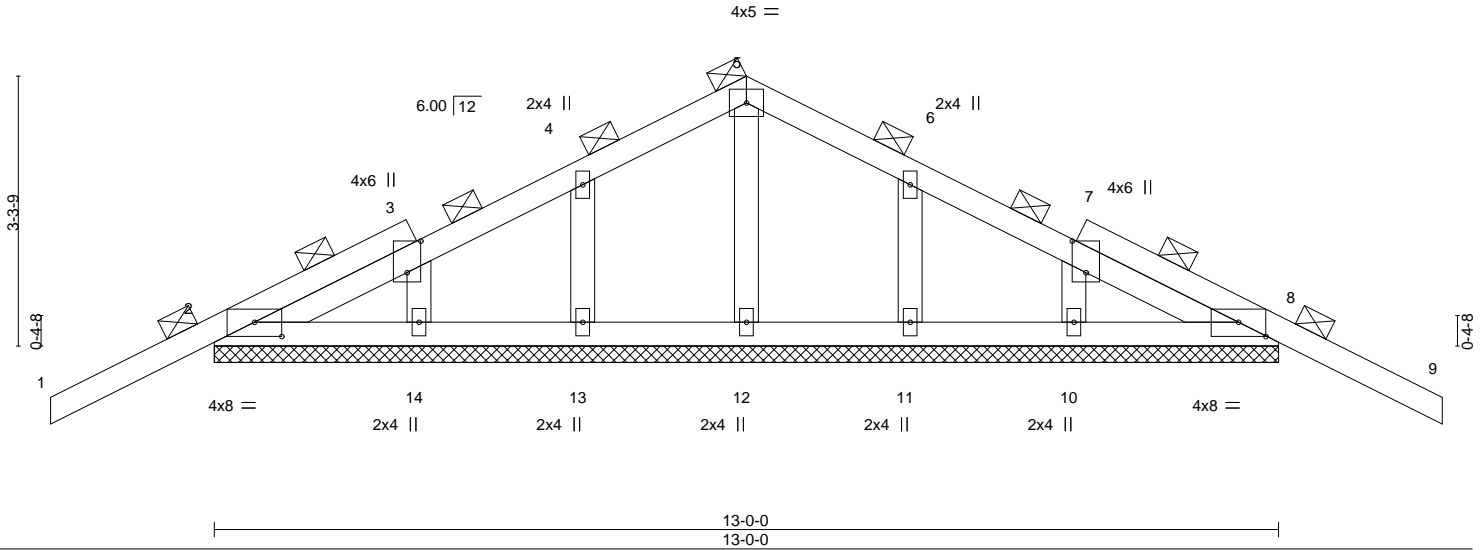

Plate Offsets (X, Y)--	[2:0-4-0,0-2-1], [3:0-4-10,0-2-0], [7:0-4-10,0-2-0], [8:0-4-0,0-2-1]
------------------------	--

LOADING (psf)	SPACING-	2-0-0	CSI.	DEFL.	in (loc)	l/defl	L/d	PLATES	GRIP
TCLL 20.0	Plate Grip DOL	1.25	TC 0.28	Vert(LL)	-0.02	9	n/r	MT20	244/190
TCDL 10.0	Lumber DOL	1.25	BC 0.04	Vert(CT)	-0.03	9	n/r		
BCLL 0.0 *	Rep Stress Incr	YES	WB 0.04	Horz(CT)	0.00	8	n/a		
BCDL 10.0	Code	FBC2023/TPI2014	Matrix-S					Weight: 66 lb	FT = 20%

LUMBER-	BRACING-
TOP CHORD 2x4 SP No.2	TOP CHORD 2-0-0 oc purlins (6-0-0 max.).
BOT CHORD 2x4 SP No.2	BOT CHORD Rigid ceiling directly applied or 10-0-0 oc bracing.
OTHERS 2x4 SP No.3	

**REACTIONS.** All bearings 13-0-0.  
 (lb) - Max Horz 2=65(LC 13)  
 Max Uplift All uplift 100 lb or less at joint(s) 2, 8, 13, 14, 11, 10  
 Max Grav All reactions 250 lb or less at joint(s) 12, 13, 14, 11, 10 except 2=263(LC 1), 8=263(LC 1)

**FORCES.** (lb) - Max. Comp./Max. Ten. - All forces 250 (lb) or less except when shown.

- NOTES-**
- 1) Unbalanced roof live loads have been considered for this design.
  - 2) Wind: ASCE 7-22; Vult=130mph (3-second gust) Vasd=101mph; TC DL=4.2psf; TCDL=3.0psf; h=20ft; Cat. II; Exp B; Encl., GCpi=0.18; MWFRS (envelope) gable end zone and C-C Zone3 zone; C-C for members and forces & MWFRS for reactions shown; Lumber DOL=1.60 plate grip DOL=1.60
  - 3) Truss designed for wind loads in the plane of the truss only. For studs exposed to wind (normal to the face), see Standard Industry Gable End Details as applicable, or consult qualified building designer as per ANSI/TPI 1.
  - 4) Building Designer / Project engineer responsible for verifying applied roof live load shown covers rain loading requirements specific to the use of this truss component.
  - 5) Gable requires continuous bottom chord bearing.
  - 6) Gable studs spaced at 2-0-0 oc.
  - 7) This truss has been designed for a 10.0 psf bottom chord live load nonconcurrent with any other live loads.
  - 8) \* This truss has been designed for a live load of 20.0psf on the bottom chord in all areas where a rectangle 3-6-0 tall by 2-0-0 wide will fit between the bottom chord and any other members.
  - 9) Provide mechanical connection (by others) of truss to bearing plate capable of withstanding 100 lb uplift at joint(s) 2, 8, 13, 14, 11, 10.
  - 10) Graphical purlin representation does not depict the size or the orientation of the purlin along the top and/or bottom chord.

This item has been digitally signed and sealed by Velez, Joaquin, PE on the date indicated here. Printed copies of this document are not considered signed and sealed and the signature must be verified on any electronic copies.

Joaquin Velez PE No.68182  
 MiTek Inc. DBA MiTek USA FL Cert 6634  
 16023 Swingley Ridge Rd.  
 Chesterfield, MO 63017

Date: December 23, 2025

<p><b>WARNING - Verify design parameters and READ NOTES ON THIS AND INCLUDED MITEK REFERENCE PAGE MII-7473 rev. 1/2/2023 BEFORE USE.</b></p> <p>Design valid for use only with MiTek® connectors. This design is based only upon parameters shown, and is for an individual building component, not a truss system. Before use, the building designer must verify the applicability of design parameters and properly incorporate this design into the overall building design. Bracing indicated is to prevent buckling of individual truss web and/or chord members only. Additional temporary and permanent bracing is always required for stability and to prevent collapse with possible personal injury and property damage. For general guidance regarding the fabrication, storage, delivery, erection and bracing of trusses and truss systems, see <b>ANSI/TPI1 Quality Criteria and DSB-22</b> available from Truss Plate Institute (www.tpinst.org) and <b>BCSI Building Component Safety Information</b> available from the Structural Building Component Association (www.sbcsccomponents.com)</p>	<p>16023 Swingley Ridge Rd.          Chesterfield, MO 63017          314.434.1200 / MiTek-US.com</p>
--	--

Job 5152938	Truss T22	Truss Type Common Girder	Qty 1	Ply 2	THIERY RES. Job Reference (optional)	T39616985
----------------	--------------	-----------------------------	----------	----------	---	-----------

Builders FirstSource (Lake City,FL), Lake City, FL - 32055,

8.830 s Sep 3 2025 MiTek Industries, Inc. Mon Dec 22 07:35:09 2025 Page 1

ID:qPB6\_vd6KiSva2ixBwiw7Vy6Vgm-TeCfBBGX1Jj8d3Vetbf7dt6JJDWpS7tQhh49Ky6U5m

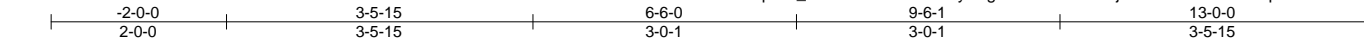

Scale = 1:26.3

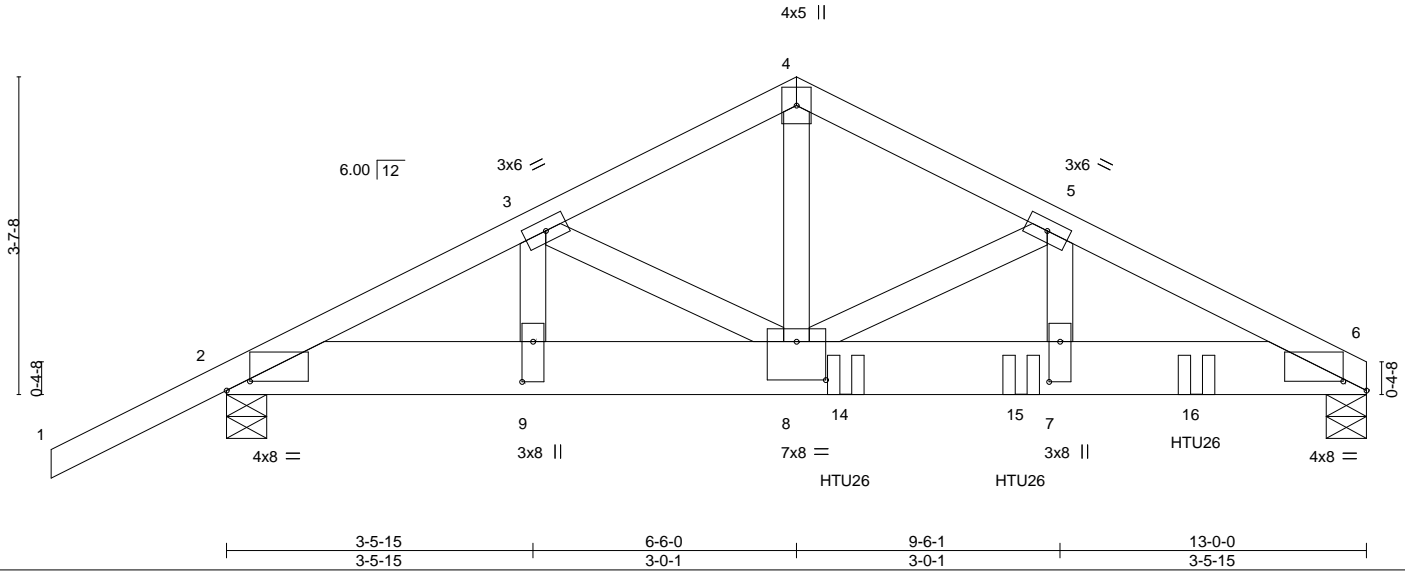

Plate Offsets (X,Y)--	[2:0-3-3,0-1-4], [6:0-3-3,0-1-4], [7:0-5-8,0-1-8], [8:0-4-0,0-5-4], [9:0-5-8,0-1-8]
-----------------------	---

LOADING (psf)	SPACING-	CSI.	DEFL.	PLATES	GRIP
TCLL 20.0	2-0-0	TC 0.28	in (loc) l/defl L/d	MT20	244/190
TCDL 10.0	Plate Grip DOL 1.25	BC 0.30	Vert(LL) -0.06 7-8 >999 240		
BCLL 0.0 *	Lumber DOL 1.25	WB 0.75	Vert(CT) -0.11 7-8 >999 180		
BCDL 10.0	Rep Stress Incr NO	Matrix-MS	Horz(CT) 0.02 6 n/a n/a		
	Code FBC2023/TPI2014			Weight: 164 lb	FT = 20%

<b>LUMBER-</b>	<b>BRACING-</b>
TOP CHORD 2x4 SP No.2	TOP CHORD Structural wood sheathing directly applied or 4-7-5 oc purlins.
BOT CHORD 2x8 SP 2400F 2.0E	BOT CHORD Rigid ceiling directly applied or 10-0-0 oc bracing.
WEBS 2x4 SP No.3	

**REACTIONS.** (size) 6=0-5-8, 2=0-5-8  
 Max Horz 2=87(LC 8)  
 Max Uplift 6=-1255(LC 9), 2=-894(LC 8)  
 Max Grav 6=3716(LC 1), 2=2350(LC 1)

**FORCES.** (lb) - Max. Comp./Max. Ten. - All forces 250 (lb) or less except when shown.  
 TOP CHORD 2-3=-4424/1691, 3-4=-4682/1862, 4-5=-4679/1855, 5-6=-6894/2468  
 BOT CHORD 2-9=-1519/3931, 8-9=-1519/3931, 7-8=-2161/6147, 6-7=-2161/6147  
 WEBS 4-8=-1573/3934, 5-8=-2274/692, 5-7=-534/1945, 3-8=-309/378, 3-9=-381/224

- NOTES-**
- 2-ply truss to be connected together with 10d (0.131"x3") nails as follows:  
 Top chords connected as follows: 2x4 - 1 row at 0-9-0 oc.  
 Bottom chords connected as follows: 2x8 - 2 rows staggered at 0-4-0 oc.  
 Webs connected as follows: 2x4 - 1 row at 0-9-0 oc.
  - All loads are considered equally applied to all plies, except if noted as front (F) or back (B) face in the LOAD CASE(S) section. Ply to ply connections have been provided to distribute only loads noted as (F) or (B), unless otherwise indicated.
  - Unbalanced roof live loads have been considered for this design.
  - Wind: ASCE 7-22; Vult=130mph (3-second gust) Vasd=101mph; TCDL=4.2psf; BCDL=3.0psf; h=20ft; Cat. II; Exp B; Encl., GCpi=0.18; MWFRS (envelope) gable end zone; Lumber DOL=1.60 plate grip DOL=1.60
  - Building Designer / Project engineer responsible for verifying applied roof live load shown covers rain loading requirements specific to the use of this truss component.
  - This truss has been designed for a 10.0 psf bottom chord live load nonconcurrent with any other live loads.
  - \* This truss has been designed for a live load of 20.0psf on the bottom chord in all areas where a rectangle 3-6-0 tall by 2-0-0 wide will fit between the bottom chord and any other members.
  - Provide mechanical connection (by others) of truss to bearing plate capable of withstanding 100 lb uplift at joint(s) except (jt=lb) 6=1255, 2=894.
  - Use Simpson Strong-Tie HTU26 (20-10d Girder, 20-10dx1 1/2 Truss, Single Ply Girder) or equivalent at 7-0-12 from the left end to connect truss(es) to front face of bottom chord.
  - Use Simpson Strong-Tie HTU26 (20-10d Girder, 11-10dx1 1/2 Truss) or equivalent spaced at 2-0-0 oc max. starting at 9-0-12 from the left end to 11-0-12 to connect truss(es) to front face of bottom chord.
  - Fill all nail holes where hanger is in contact with lumber.

**LOAD CASE(S)** Standard

This item has been digitally signed and sealed by Velez, Joaquin, PE on the date indicated here. Printed copies of this document are not considered signed and sealed and the signature must be verified on any electronic copies.

Joaquin Velez PE No.68182  
 MiTek Inc. DBA MiTek USA FL Cert 6634  
 16023 Swingley Ridge Rd.  
 Chesterfield, MO 63017  
 Date:

December 23,2025

Continued on page 2

<p><b>WARNING - Verify design parameters and READ NOTES ON THIS AND INCLUDED MITEK REFERENCE PAGE MII-7473 rev. 1/2/2023 BEFORE USE.</b></p> <p>Design valid for use only with MiTek® connectors. This design is based only upon parameters shown, and is for an individual building component, not a truss system. Before use, the building designer must verify the applicability of design parameters and properly incorporate this design into the overall building design. Bracing indicated is to prevent buckling of individual truss web and/or chord members only. Additional temporary and permanent bracing is always required for stability and to prevent collapse with possible personal injury and property damage. For general guidance regarding the fabrication, storage, delivery, erection and bracing of trusses and truss systems, see <b>ANSI/TPI1 Quality Criteria and DSB-22</b> available from Truss Plate Institute (www.tpinst.org) and <b>BCSI Building Component Safety Information</b> available from the Structural Building Component Association (www.sbcsccomponents.com)</p>	 <p>16023 Swingley Ridge Rd.        Chesterfield, MO 63017        314.434.1200 / MiTek-US.com</p>
--	--

Job 5152938	Truss T22	Truss Type Common Girder	Qty 1	Ply <b>2</b>	THIERY RES. Job Reference (optional)	T39616985
----------------	--------------	-----------------------------	----------	-----------------	---	-----------

Builders FirstSource (Lake City,FL), Lake City, FL - 32055,

8.830 s Sep 3 2025 MiTek Industries, Inc. Mon Dec 22 07:35:09 2025 Page 2  
ID:qPB6\_vd6KiSva2ixBwiw7Vy6Vgm-TeCfBBGX1Jj8d3Vetbbf7dt6JDWpS7tQhh49Ky6U5m

**LOAD CASE(S)** Standard

- 1) Dead + Roof Live (balanced): Lumber Increase=1.25, Plate Increase=1.25  
Uniform Loads (plf)  
Vert: 1-4=-60, 4-6=-60, 2-6=-20  
Concentrated Loads (lb)  
Vert: 14=-2565(F) 15=-1170(F) 16=-1170(F)

**WARNING - Verify design parameters and READ NOTES ON THIS AND INCLUDED MITEK REFERENCE PAGE MII-7473 rev. 1/2/2023 BEFORE USE.**

Design valid for use only with MiTek® connectors. This design is based only upon parameters shown, and is for an individual building component, not a truss system. Before use, the building designer must verify the applicability of design parameters and properly incorporate this design into the overall building design. Bracing indicated is to prevent buckling of individual truss web and/or chord members only. Additional temporary and permanent bracing is always required for stability and to prevent collapse with possible personal injury and property damage. For general guidance regarding the fabrication, storage, delivery, erection and bracing of trusses and truss systems, see **ANSI/TPI1 Quality Criteria and DSB-22** available from Truss Plate Institute ([www.tpinst.org](http://www.tpinst.org)) and **BCSI Building Component Safety Information** available from the Structural Building Component Association ([www.sbcsccomponents.com](http://www.sbcsccomponents.com))

**MiTek**®

16023 Swingley Ridge Rd.  
Chesterfield, MO 63017  
314.434.1200 / MiTek-US.com

# Symbols

## PLATE LOCATION AND ORIENTATION

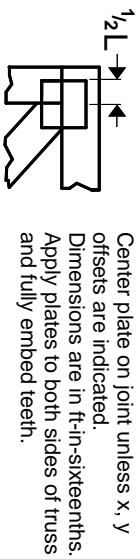

Center plate on joint unless x, y offsets are indicated. Dimensions are in ft-in-sixteenths. Apply plates to both sides of truss and fully embed teeth.

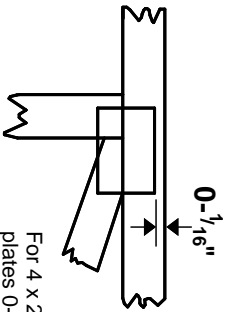

For 4 x 2 orientation, locate plates 0- 1/16" from outside edge of truss.



This symbol indicates the required direction of slots in connector plates.

\* Plate location details available in MITtek software or upon request.

## PLATE SIZE

4 X 4

The first dimension is the plate width measured perpendicular to slots. Second dimension is the length parallel to slots.

## LATERAL BRACING LOCATION



Indicated by symbol shown and/or by text in the bracing section of the output. Use T or I bracing if indicated.

## BEARING

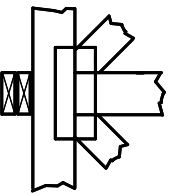

Indicates location where bearings (supports) occur. Icons vary but reaction section indicates joint number/letter where bearings occur. Min size shown is for crushing only.

## Industry Standards:

ANSI/TFP1: National Design Specification for Metal Plate Connected Wood Truss Construction.  
DSB-22: Design Standard for Bracing.  
BCSI: Building Component Safety Information, Guide to Good Practice for Handling, Installing, Restraining & Bracing of Metal Plate Connected Wood Trusses.

# Numbering System

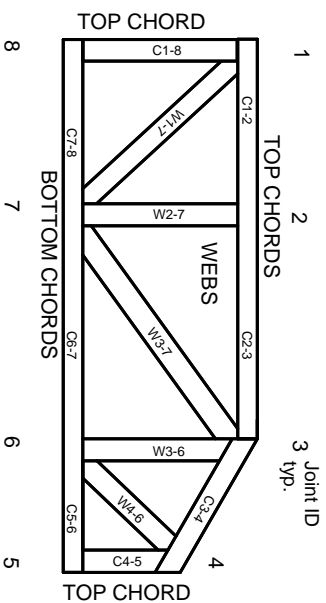

JOINTS ARE GENERALLY NUMBERED/LETTERED CLOCKWISE AROUND THE TRUSS STARTING AT THE JOINT FARTHEST TO THE LEFT.

CHORDS AND WEBS ARE IDENTIFIED BY END JOINT NUMBERS/LETTERS.

## Product Code Approvals

ICC-ES Reports:

ESR-1-1988, ESR-2362, ESR-2685, ESR-3282  
ESR-4722, ESL-1388

## Design General Notes

Trusses are designed for wind loads in the plane of the truss unless otherwise shown.

Lumber design values are in accordance with ANSI/TFP 1 section 6.3. These truss designs rely on Lumber values established by others.

© 2023 MITtek® All Rights Reserved

# General Safety Notes

## Failure to Follow Could Cause Property Damage or Personal Injury

1. Additional stability/bracing for truss system, e.g. diagonal or X-bracing, is always required. See BCSI.
2. Truss bracing must be designed by an engineer. For wide truss spacing, individual lateral braces themselves may require bracing, or alternative Tor I bracing should be considered.
3. Never exceed the design loading shown and never stack materials on inadequately braced trusses.
4. Provide copies of this truss design to the building designer, erection supervisor, property owner and all other interested parties.
5. Cut members to bear tightly against each other.
6. Place plates on each face of truss at each joint and embed fully. Knots and wane at joint locations are regulated by ANSI/TFP 1.
7. Design assumes trusses will be suitably protected from the environment in accord with ANSI/TFP 1.
8. Unless otherwise noted, moisture content of lumber shall not exceed 19% at time of fabrication.
9. Unless expressly noted, this design is not applicable for use with fire retardant, preservative treated, or green lumber.
10. Camber is a non-structural consideration and is the responsibility of truss fabricator. General practice is to camber for dead load deflection.
11. Plate type, size, orientation and location dimensions indicated are minimum plating requirements.
12. Lumber used shall be of the species and size, and in all respects, equal to or better than that specified.
13. Top chords must be sheathed or purlins provided at spacing indicated on design.
14. Bottom chords require lateral bracing at 10 ft. spacing, or less, if no ceiling is installed, unless otherwise noted.
15. Connections not shown are the responsibility of others.
16. Do not cut or alter truss member or plate without prior approval of an engineer.
17. Install and load vertically unless indicated otherwise.
18. Use of green or treated lumber may pose unacceptable environmental, health or performance risks. Consult with project engineer before use.
19. Review all portions of this design (front, back, words and pictures) before use. Reviewing pictures alone is not sufficient.
20. Design assumes manufacture in accordance with ANSI/TFP 1 Quality Criteria.
21. The design does not take into account any dynamic or other loads other than those expressly stated.

# MITek®

MITtek Engineering Reference Sheet: Mill-7473 rev. 1/2/2023