

APPLICABLE CODES AND STANDARDS

- 2023 FLORIDA BUILDING CODE (8TH EDITION)
- 2021 INTERNATIONAL BUILDING CODE
- ASCE 7-22: MINIMUM DESIGN LOADS ON BUILDINGS AND OTHER STRUCTURES
- AISC STEEL CONSTRUCTION MANUAL (15TH EDITION)
- ACI 318-14: BUILDING CODE REQUIREMENTS FOR STRUCTURAL CONCRETE
- TMS 402-16: BUILDING CODE REQUIREMENTS FOR MASONRY STRUCTURES
- AWS D1.1: STRUCTURAL WELDING

DESIGN LOADS

- DEAD LOAD = 15 PSF
- LIVE LOAD = 20 PSF
- WIND LOAD (SEE TABLE 1)

ENCLOSED METAL BUILDING DESIGN

30FT WIDE X 40FT LONG X 12FT EAVE HT.

INSTALLATION NOTES AND SPECIFICATIONS

- ROOF PITCH SHALL NOT BE GREATER THAN 12H:4V
- END WALL COLUMNS (POST) AND SIDE WALL COLUMNS ARE THE SAME U.N.O.
- 29 GA METAL PANELS SHALL BE FASTENED DIRECTLY TO 2.5" x 2.5" x 14 GA TUBE STEEL (TS) FRAMING MEMBERS FOR VERTICAL PANELS.
 - 29 GA METAL PANELS SHALL BE FASTENED DIRECTLY TO 18 GA HAT CHANNELS U.N.O.
 - 18 GA HAT CHANNELS SHALL BE SPACED 48" O.C. UNLESS DESIGN PRESSURES FROM TABLE 3 EXCEED THE MAX ALLOWABLE PRESSURES IN TABLE 2. THEN THE SPACING SHALL BE 24" O.C. IN THE ZONES THAT EXCEED THE MAX PRESSURES.
- FASTENER SPACING ON-CENTERS ALONG RAFTERS OR PURLINS, AND POSTS SHALL BE:
 - INTERIOR = 9"
 - END = 6"
- FASTENERS SHALL BE #12-14 x 3/4" SELF-DRILLING SCREWS (SDS), USE CONTROL SEAL WASHER WITH EXTERIOR FASTENERS. APPLICABLE ONLY FOR:
 - MEAN ROOF HEIGHT OF 20'-0" OR LESS
 - ROOF SLOPES OF 18° (4:12 PITCH) OR LESS.
 - SPACING REQUIREMENTS FOR OTHER ROOF HEIGHTS AND/OR SLOPES MAY VARY.
- ANCHORS SHALL BE INSTALLED THROUGH THE BASE RAIL WITHIN 6" OF EACH RAFTER COLUMN ALONG SIDES AND ENDS.
- STANDARD GROUND ANCHORS (SOIL NAILS) CONSIST OF #4 REBAR WITH WELDED NUT x 30" LONG AND MAY BE USED IN SUITABLE SOILS.
 - OPTIONAL ANCHORAGE MAY BE USED IN SUITABLE SOILS AND MUST BE USED IN UNSUITABLE SOILS AS NOTED. SOIL NAILS MAY BE USED FOR WIND SPEEDS LESS THAN OR EQUAL TO 145 MPH.

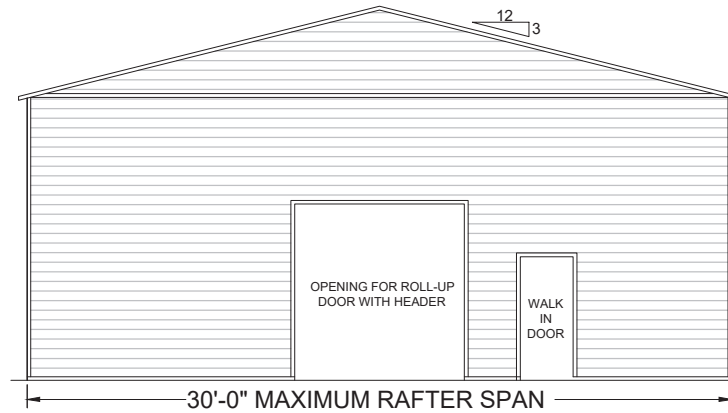

TYPICAL ELEVATION - BOX EAVE
SCALE: NTS

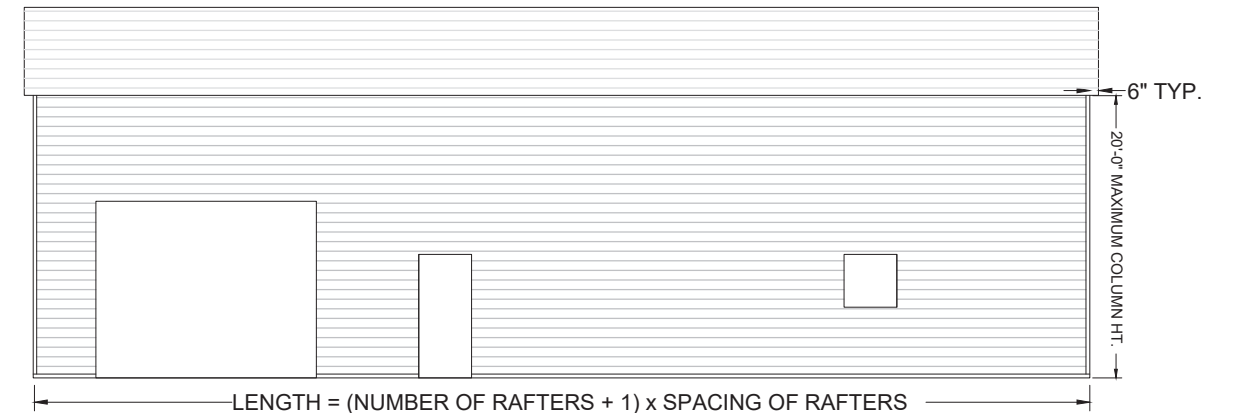

TYPICAL SIDE ELEVATION
SCALE: NTS

TABLE 1 BOW/RAFTER FRAME, END POST, GROUND ANCHOR AND PANEL FASTENER SPACING SPECIFICATIONS						
RISK CATEGORY	WIND EXPOSURE CATEGORY	ULT WIND SPEED (MPH)	NOMINAL WIND SPEED (MPH)	MAXIMUM RAFTER/BOW AND END POST SPACING (FEET)	FASTENER SPACING O.C FOR RAFTERS/PURLINS, & POSTS (INCHES)	
					INTERIOR BOWS/RAFTERS	END BOWS/RAFTERS
I, II, III, or IV	B, C, or D	115 - 150	89 - 116	5.0	6	6
		151 - 180	117 - 139	4.0	6	6

NOTES:
1. SPECIFICATIONS APPLICABLE TO 26 OR 29 GAUGE METAL PANELS FASTENED DIRECTLY TO 12 OR 14 GAUGE STEEL TUBE BOW FRAMES.
2. FASTENERS CONSIST OF 1/4"-14X1" SELF-DRILLING SCREWS WITH CONTROL SEAL WASHER.
3. SPECIFICATIONS APPLICABLE ONLY FOR MEAN ROOF HEIGHT OF 20 FEET OR LESS, AND ROOF SLOPES OF 14°(3:12 PITCH). SPACING REQUIREMENTS FOR OTHER ROOF HEIGHTS AND/OR SLOPES MAY VARY.
4. GROUND ANCHOR REQUIREMENTS ARE 1 @ EACH CORNER AND ONE EVERY OTHER INTERIOR BOW/RAFTER POST LOCATION, AT MAXIMUM OF 10' O.C., AND BOTH SIDES OF OPENINGS WHERE BASE RAIL IS ABSENT.
5. GROUND ANCHORS ARE NOT REQUIRED WITH CONCRETE SLAB CONSTRUCTION.

TABLE 2		
MEMBER	PRODUCT APPROVAL NUMBER	MAX WIND DESIGN PRESSURES
ROOF PANELS	FL39466	+41.6 PSF / -31.2 PSF
WALL PANELS	FL39594	+55.4 PSF / -41.6 PSF
GARAGE DOOR	CTP	CTP
WALK-IN DOOR	CTP	CTP

CTP = CONTRACTOR TO PROVIDE 2023 FBC APPROVED PRODUCTS THAT MEET OR EXCEED DESIGN PRESSURES AS TABULATED.

LEAN-TO INDEX	
BUILDING SIDE	LEAN-TO SIZE (FT)
LEFT	
RIGHT	
FRONT	
REAR	

DRAWING INDEX

PAGE NO.	DESCRIPTION
S-1	NOTES AND SPECIFICATIONS
S-2	BOX-BOW EAVE FRAME RAFTER ENCLOSED BUILDING
S-3	CONNECTION DETAILS (1 OF 4)
S-4	BASE RAIL AND ANCHORAGE DETAILS
S-5	BOX EAVE RAFTER END WALL, SIDE WALL AND OPENING FRAMING
S-6	CONNECTION DETAILS (2 OF 4)
S-7	CONNECTION DETAILS (3 OF 4)
S-8	BOX EAVE RAFTER LEAN-TO OPTIONS
S-9	FREESTANDING BOX EAVE RAFTER LEAN-TO OPTIONS
S-10	CONNECTION DETAILS (4 OF 4)
S-11	BOX EAVE RAFTER VERTICAL ROOF-SIDING OPTION
S-12	OPTIONAL CONCRETE STRIP FOOTING
S-13	OPTIONAL HELICAL ANCHORING DETAIL

TABLE 3 COMPONENTS AND CLADDING DESIGN PRESSURES MEAN ROOF HT 25 FT, EXPOSURE C (PSF)														
Zone	120		130		140		150		160		170		180	
	POS	NEG	POS	NEG	POS	NEG	POS	NEG	POS	NEG	POS	NEG	POS	NEG
1	9.7	-20.7	11.5	-24.3	13.2	-28.2	15.3	-32.4	17.4	-36.9	19.6	-41.6	22.0	-46.6
2	9.7	-27.9	11.5	-32.8	13.2	-38.1	15.3	-43.7	17.4	-49.7	19.6	-56.2	22.0	-62.9
3	11.1	-44.8	13.0	-52.7	15.0	-61.0	17.1	-70.1	19.6	-79.8	22.1	-90.0	24.7	-100.8
4	17.8	-19.6	20.9	-23.1	24.3	-26.7	27.9	-30.6	31.7	-34.8	35.8	-39.4	40.1	-44.1
5	18.8	-23.8	22.0	-27.8	25.5	-32.3	29.3	-37.0	33.3	-42.1	37.7	-47.5	42.3	-53.3

s:\ace dropbox\PROJECTS\lite-22047\support\30-enclosed-building\Enclosed-Building-30.dwg, USER, 9/22/2023 1:08 PM

NO.	REVISIONS	DATE	DATE	2026.02.17	SUBMITTALS	DATE	PREPARED BY	CLIENT	SHEET TITLE	PROJECT	SHEET NO.
			DRAWN	SM			 ADAM COLLINS ENGINEERING INC. <small>CA# 31728 - P. 386.320.7400 - WWW.COLLINSENG.COM</small>	ELITE METAL MANUFACTURING 10121 88TH TRACE	NOTES AND SPECIFICATIONS	Brandon Reeves 1432 SE CR 349 Lake City, FL 32025	S-1
			DESIGNED	DMC							SCALE
			CHECKED	ATC							AS-SHOWN
			JOB No.	22047							

THIS DOCUMENT HAS BEEN DIGITALLY SIGNED AND SEALED BY ADAM T. COLLINS, P.E. ON 2026.02.17. PRINTED COPIES OF THIS DOCUMENT ARE NOT CONSIDERED SIGNED AND SEALED AND THE SIGNATURE MUST BE VERIFIED ON ANY ELECTRONIC COPIES.

ADAM T. COLLINS
LICENSE
No. 75584
STATE OF FLORIDA
PROFESSIONAL ENGINEER

d:\ACE\ace - projects\elite-22047\Cadd\enclosed-building-302.dwg, USER, 12/12/2022 1:49 PM

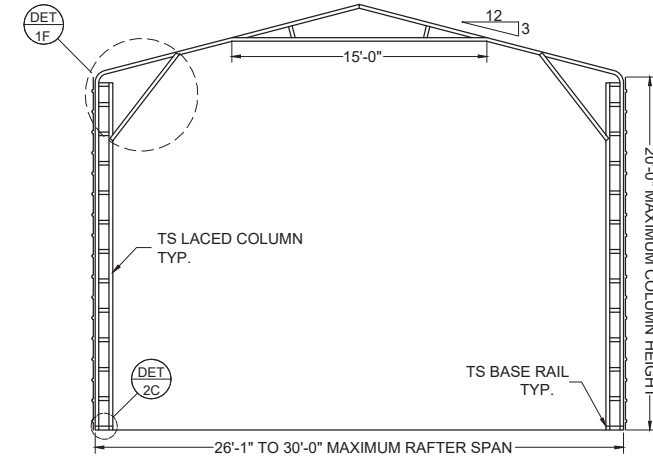
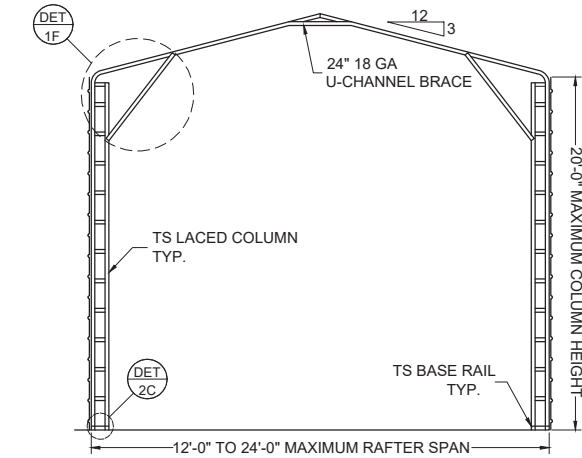
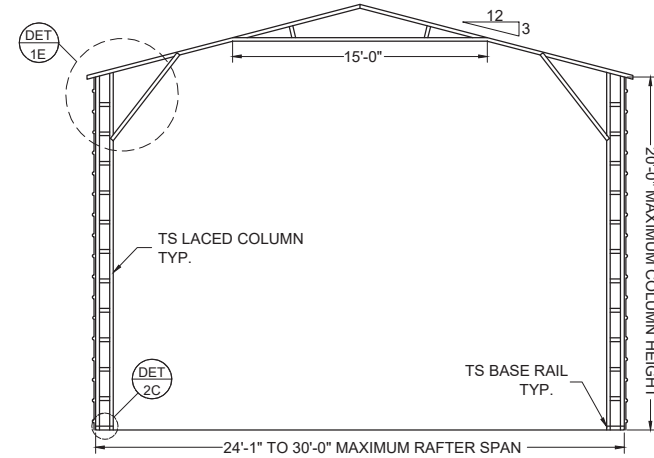
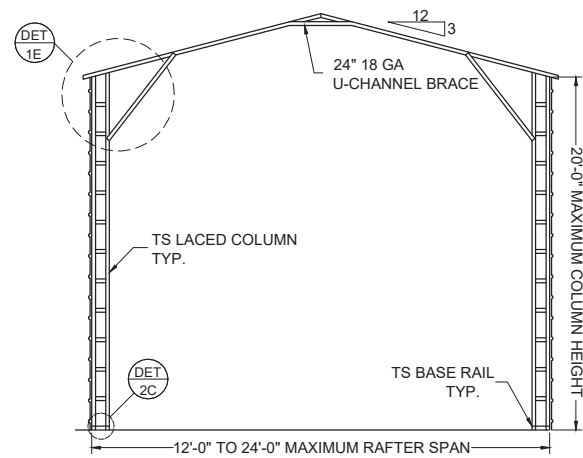
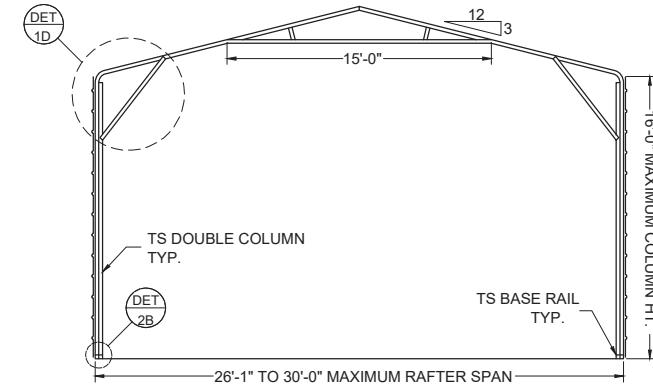
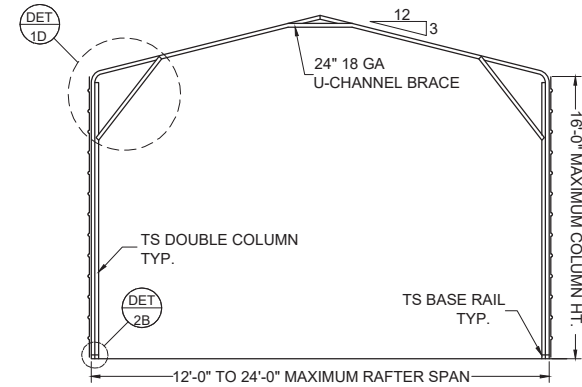
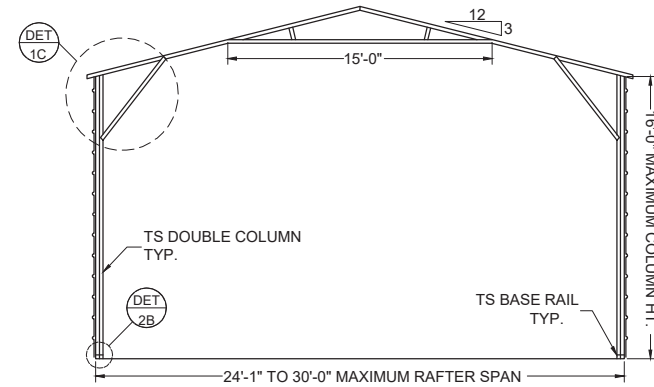
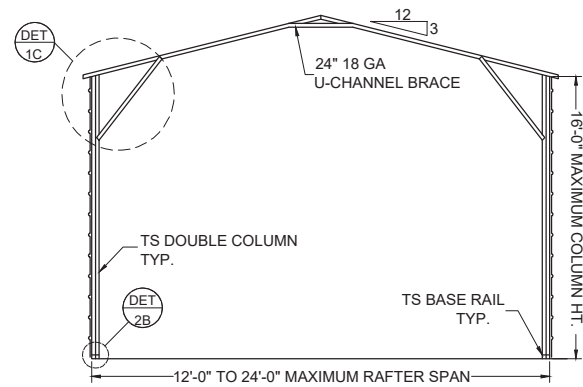
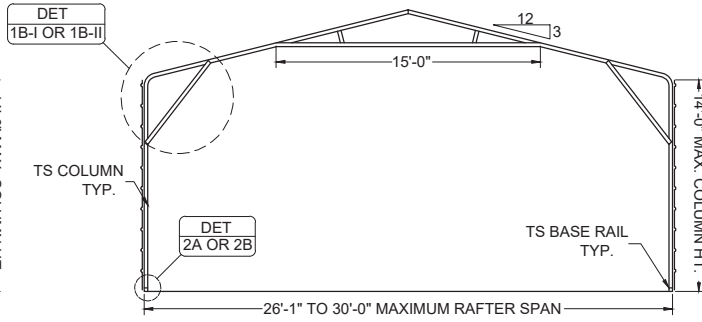
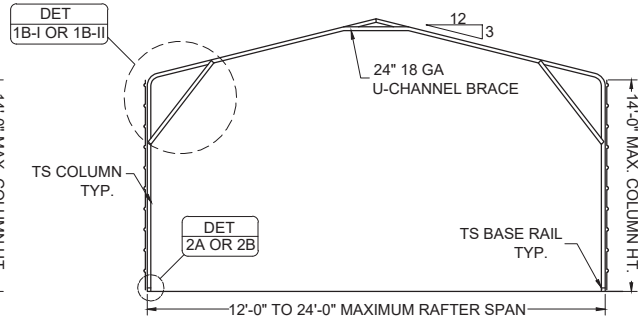
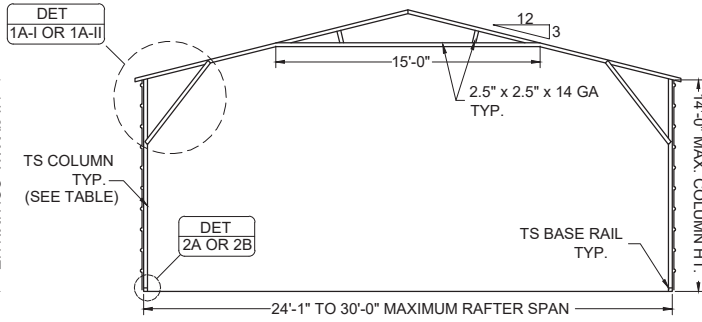
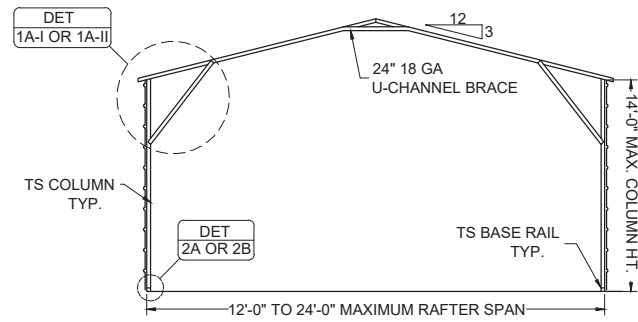

BOX EAVE FRAME

SCALE: NTS

BOW EAVE FRAME

SCALE: NTS

THIS DOCUMENT HAS BEEN DIGITALLY SIGNED AND SEALED BY ADAM T. COLLINS, P.E. ON 2026.02.17. PRINTED COPIES OF THIS DOCUMENT ARE NOT CONSIDERED SIGNED AND SEALED AND THE SIGNATURE MUST BE VERIFIED ON ANY ELECTRONIC COPIES.

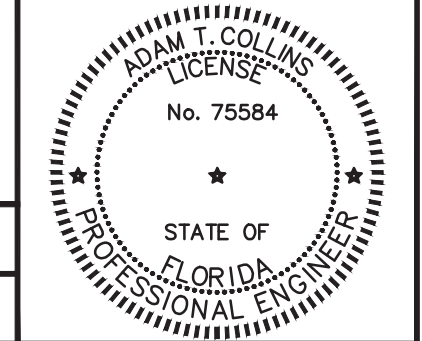

NO.	REVISIONS	DATE	DATE	2026.02.17	SUBMITTALS	DATE	PREPARED BY	CLIENT	SHEET TITLE	PROJECT	SHEET NO.
			DRAWN	SM			ADAM COLLINS ENGINEERING INC. CA# 31728 - P: 386.320.7400 - WWW.COLLINSENG.COM	ELITE METAL MANUFACTURING 10121 88TH TRACE	BOX-BOW EAVE FRAME RAFTER ENCLOSED BUILDING	Brandon Reeves 1432 SE CR 349 Lake City, FL 32025	S-2
			DESIGNED	DMC		SCALE					
			CHECKED	ATC		AS-SHOWN					
			JOB No.	22047							

d:\ACE\ace - projects\elite-22047\Cadd\enclosed-building-30\3.dwg, USER: 12/12/2022 1:49 PM

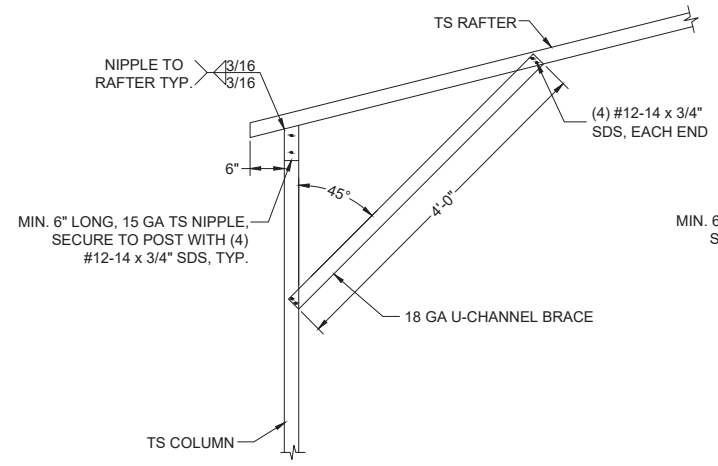

1A-I BOX EAVE RAFTER/CORNER POST CONNECTION 30'(MAX.)W x 14'H
SCALE: NTS

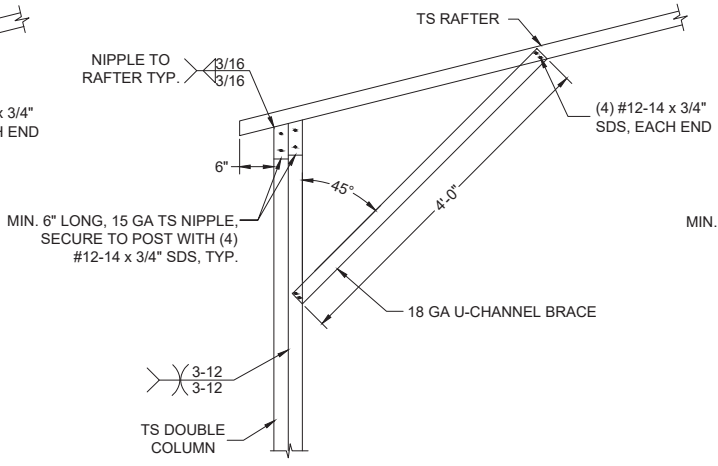

1A-II BOX EAVE RAFTER/CORNER POST CONNECTION 30'(MAX.)W x 14'H
SCALE: NTS

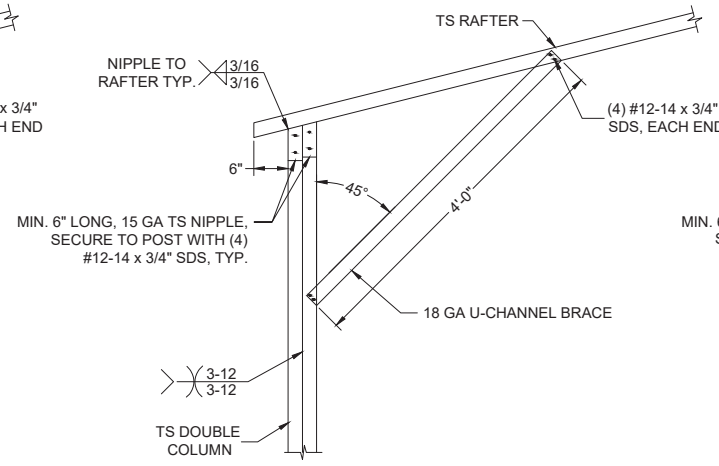

1C BOX EAVE RAFTER/CORNER POST CONNECTION 30'(MAX.)W x 16'H
SCALE: NTS

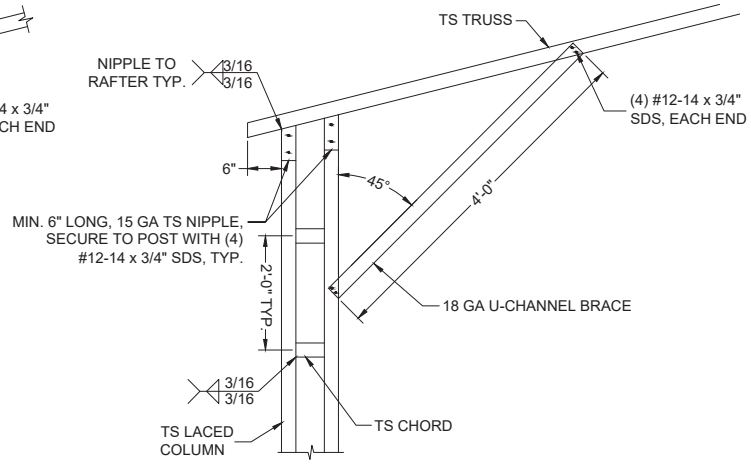

1E BOX EAVE RAFTER/CORNER POST CONNECTION 30'(MAX.)W x 20'H
SCALE: NTS

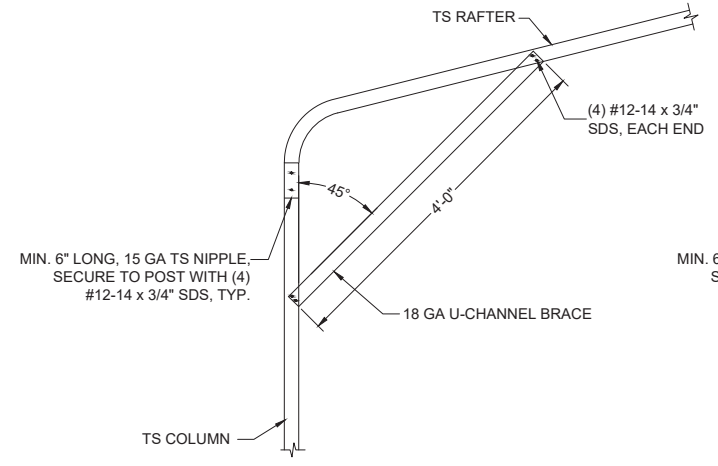

1B-I BOW EAVE RAFTER/CORNER POST CONNECTION 30'(MAX.)W x 14'H
SCALE: NTS

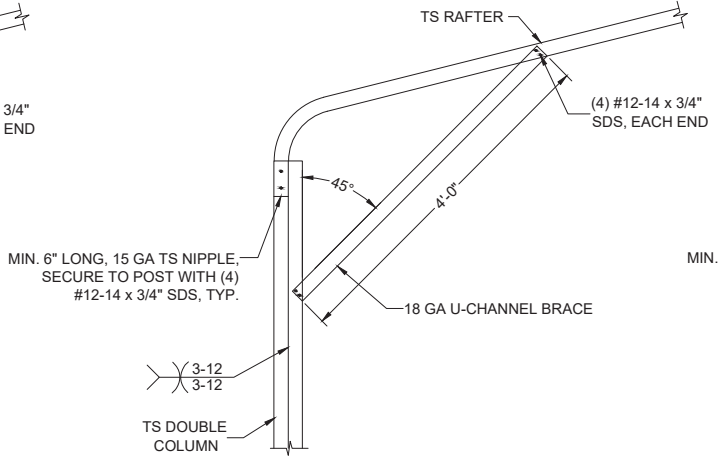

1B-II BOW EAVE RAFTER/CORNER POST CONNECTION 30'(MAX.)W x 14'H
SCALE: NTS

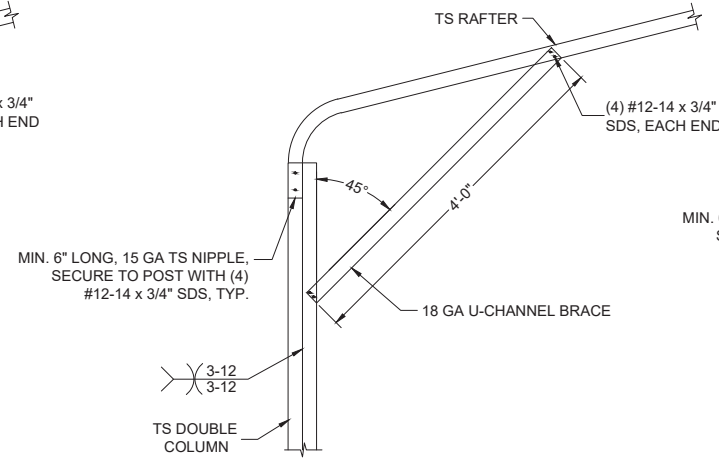

1D BOW EAVE RAFTER/CORNER POST CONNECTION 30'(MAX.)W x 16'H
SCALE: NTS

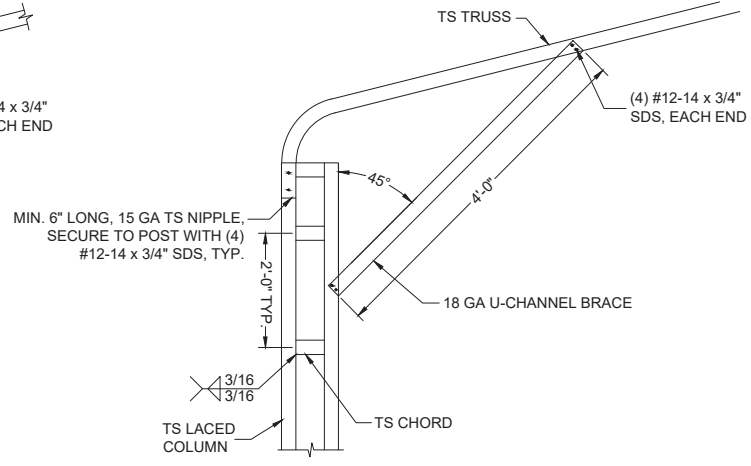

1F BOW EAVE RAFTER/CORNER POST CONNECTION 30'(MAX.)W x 20'H
SCALE: NTS

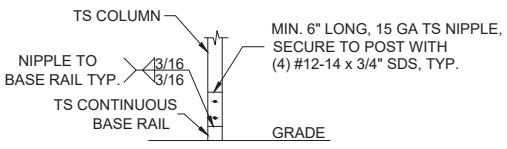

2A POST/BASE RAIL CONNECTION
SCALE: NTS

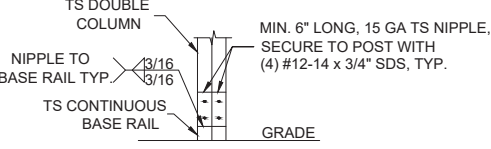

2B POST/BASE RAIL CONNECTION
SCALE: NTS

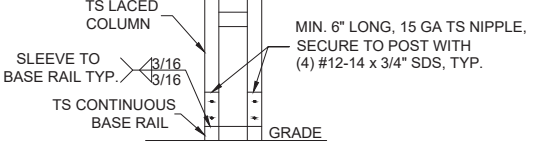

2C POST/BASE RAIL CONNECTION
SCALE: NTS

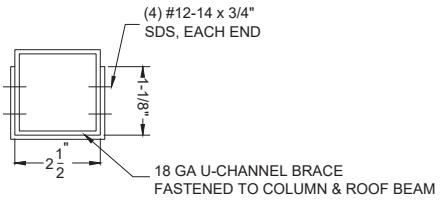

BRACE SECTION
SCALE: NTS

THIS DOCUMENT HAS BEEN DIGITALLY SIGNED AND SEALED BY ADAM T. COLLINS, P.E. ON 2026.02.17. PRINTED COPIES OF THIS DOCUMENT ARE NOT CONSIDERED SIGNED AND SEALED AND THE SIGNATURE MUST BE VERIFIED ON ANY ELECTRONIC COPIES.

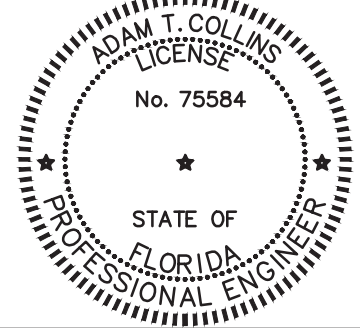

NO.	REVISIONS	DATE	DATE	2026.02.17	SUBMITTALS	DATE	PREPARED BY	CLIENT	SHEET TITLE	PROJECT	SHEET NO.
							ADAM COLLINS ENGINEERING INC.	ELITE METAL MANUFACTURING 10121 88TH TRACE	CONNECTION DETAILS (1 OF 4)	Brandon Reeves 1432 SE CR 349 Lake City, FL 32025	S-3
											SCALE AS-SHOWN

GENERAL NOTES

MINIMUM SOIL BEARING CAPACITY: 1500 PSF.
 CONCRETE STRENGTH: 3000 PSI @ 28 DAYS

REINFORCING STEEL

1. REBAR SHALL BE ASTM A615 GRADE 60
2. SLAB REINFORCEMENT = WELDED WIRE FABRIC PER ASTM A185 OR FIBERGLASS FIBER REINFORCEMENT
3. CONCRETE COVER SHALL BE
 - 3.1. 3" WHERE EXPOSED TO SOIL OR WATER.
 - 3.2. 2" EVERYWHERE ELSE.
4. REBAR SHALL BE BENT WITHOUT HEATING.
5. MINIMUM BEND = 6 X BAR DIAMETER
6. REINFORCEMENT PARTIALLY EMBEDDED IN CONCRETE SHALL NOT BE FIELD BENT.

HELIX ANCHOR NOTES

1. USE MINIMUM (2) 4" HELICES WITH 30" EMBEDMENT FOR THE FOLLOWING SOILS:
 - 1.1. VERY DENSE AND/OR CEMENTED SANDS
 - 1.2. COARSE GRAVEL AND COBBLES
 - 1.3. CALICHE
 - 1.4. PRELOADED SILTS AND CLAYS
 - 1.5. CORALS
 - 1.6. MEDIUM DENSE COARSE SANDS
 - 1.7. SANDY GRAVEL
 - 1.8. VERY STIFF SILTS AND CLAYS
2. USE MINIMUM (2) 6" HELICES WITH MINIMUM 48" EMBEDMENT FOR
 - 2.1. LOOSE TO MEDIUM DENSE SANDS
 - 2.2. FIRM TO STIFF CLAYS AND SILTS
 - 2.3. ALLUVIAL FILL
3. USE MINIMUM (2) 8" HELICES WITH MINIMUM 60" EMBEDMENT.
 - 3.1. FOR VERY LOOSE TO MEDIUM DENSE SANDS
 - 3.2. FIRM TO STIFFER CLAYS AND SILTS
 - 3.3. ALLUVIAL FILL,

MONOLITHIC FOOTER SIZE	
110 C - 140 C	8" x 12" - (2) #4
ABOVE 140 C	12" x 16" - (2) #4

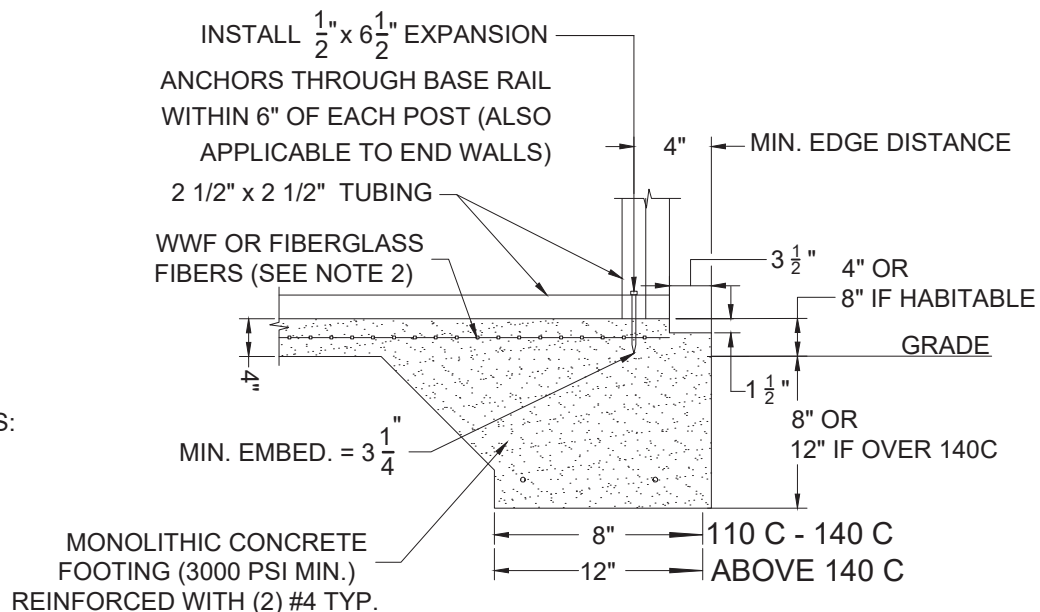

3A
SCALE: NTS

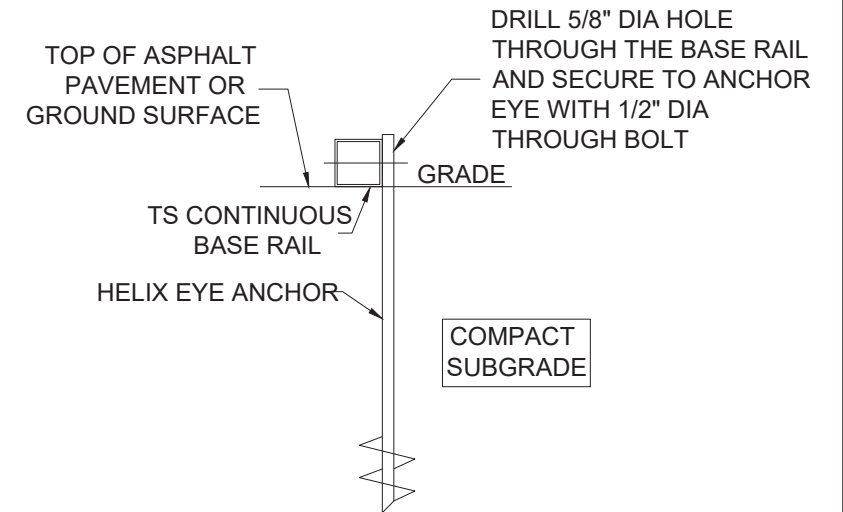

3B
SCALE: NTS

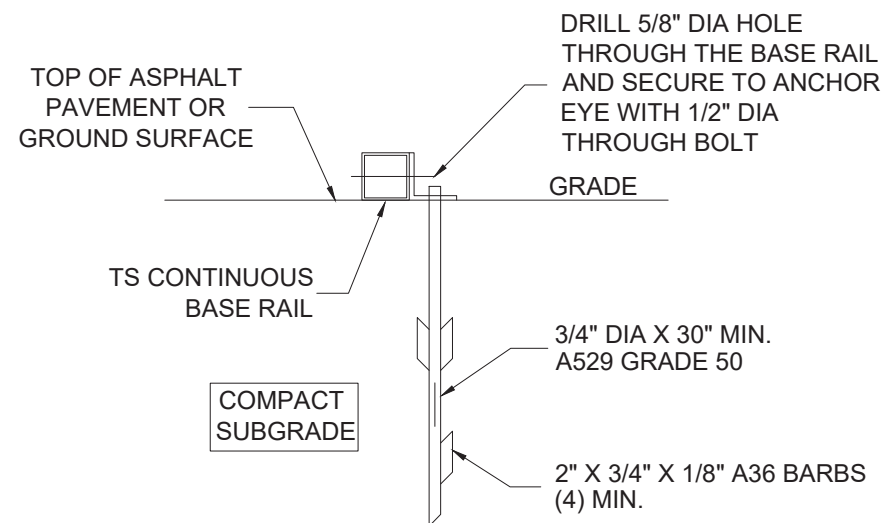

3C
SCALE: NTS

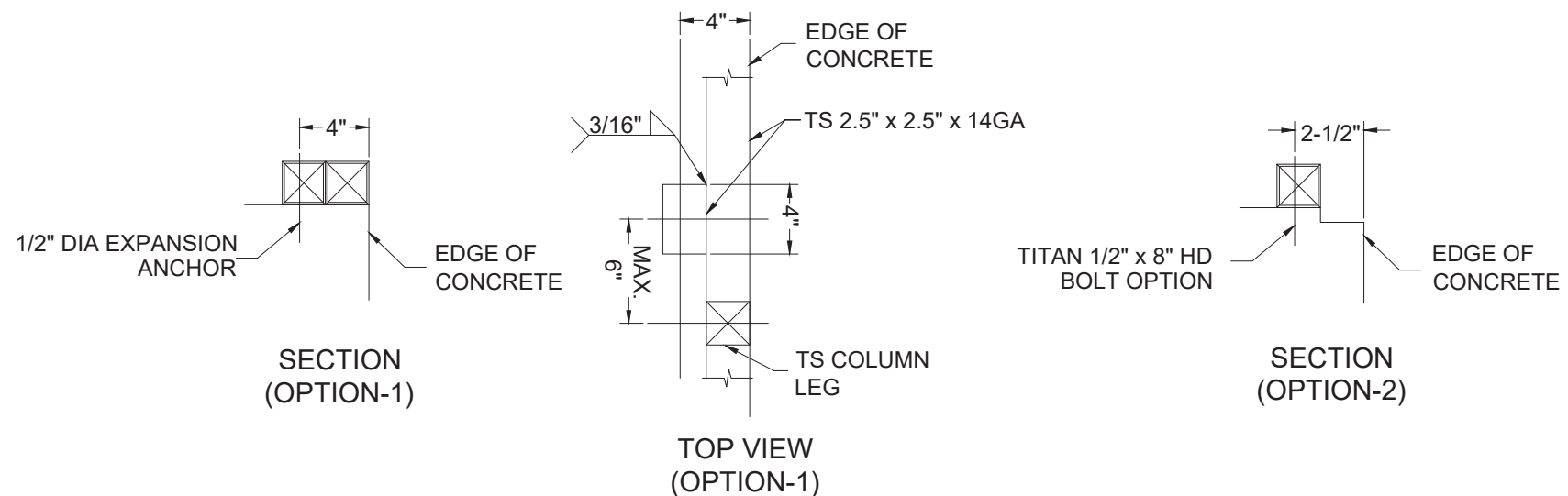

TYPICAL ANCHOR DETAIL WHEN BASE RAIL IS NEAR EDGE OF CONCRETE
SCALE: NTS

THIS DOCUMENT HAS BEEN DIGITALLY SIGNED AND SEALED BY ADAM T. COLLINS, P.E. ON 2026.02.17. PRINTED COPIES OF THIS DOCUMENT ARE NOT CONSIDERED SIGNED AND SEALED AND THE SIGNATURE MUST BE VERIFIED ON ANY ELECTRONIC COPIES.

ADAM T. COLLINS
 LICENSE
 No. 75584
 STATE OF
 FLORIDA
 PROFESSIONAL ENGINEER

d:\ACE\ace - projects\elite-22047\Cadd\enclosed-building-304.dwg, USER: 12/12/2022 1:49 PM

NO.	REVISIONS	DATE	DATE	2026.02.17	SUBMITTALS	DATE	PREPARED BY	CLIENT	SHEET TITLE	PROJECT	SHEET NO.
				2026.02.17			ADAM COLLINS ENGINEERING INC.	ELITE METAL MANUFACTURING 10121 88TH TRACE	BASE RAIL AND ANCHORAGE DETAILS	Brandon Reeves 1432 SE CR 349 Lake City, FL 32025	S-4
											SCALE AS-SHOWN

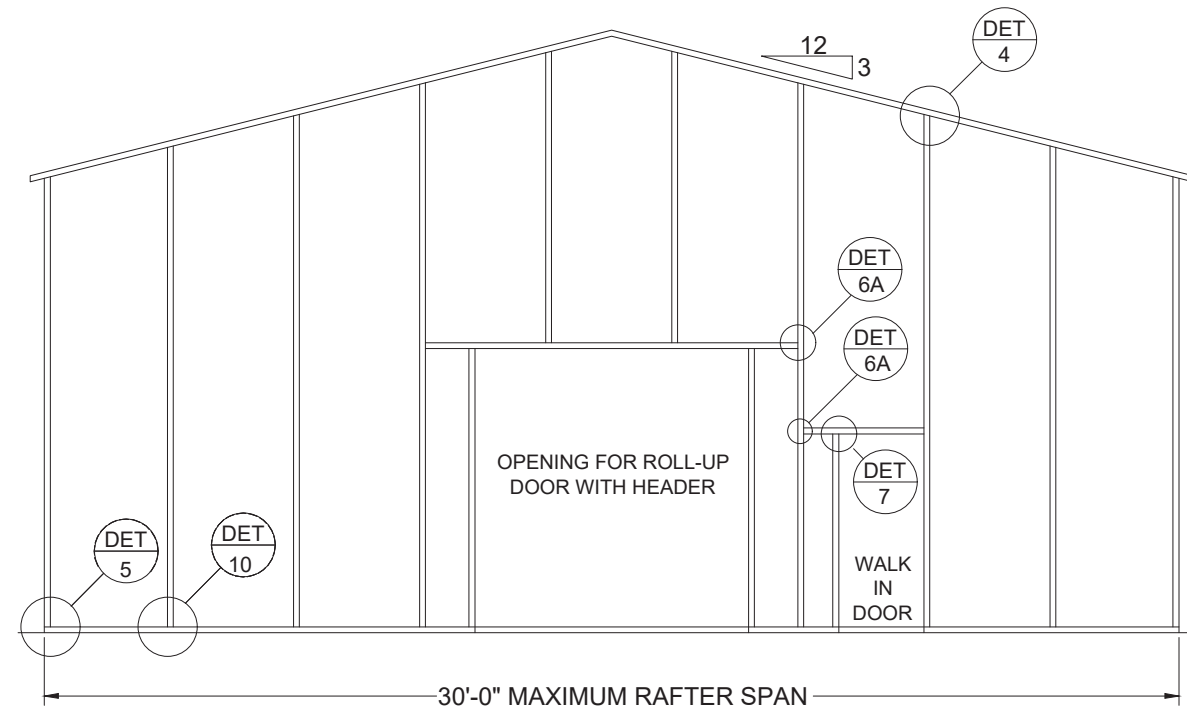

SPACING = 5'-0" FOR WIND SPEEDS BETWEEN 110 MPH AND 140 MPH
 SPACING = 4'-0" FOR WIND SPEEDS BETWEEN 140 MPH AND 180 MPH

TYPICAL BOX EAVE RAFTER END WALL FRAMING SECTION
 SCALE: NTS

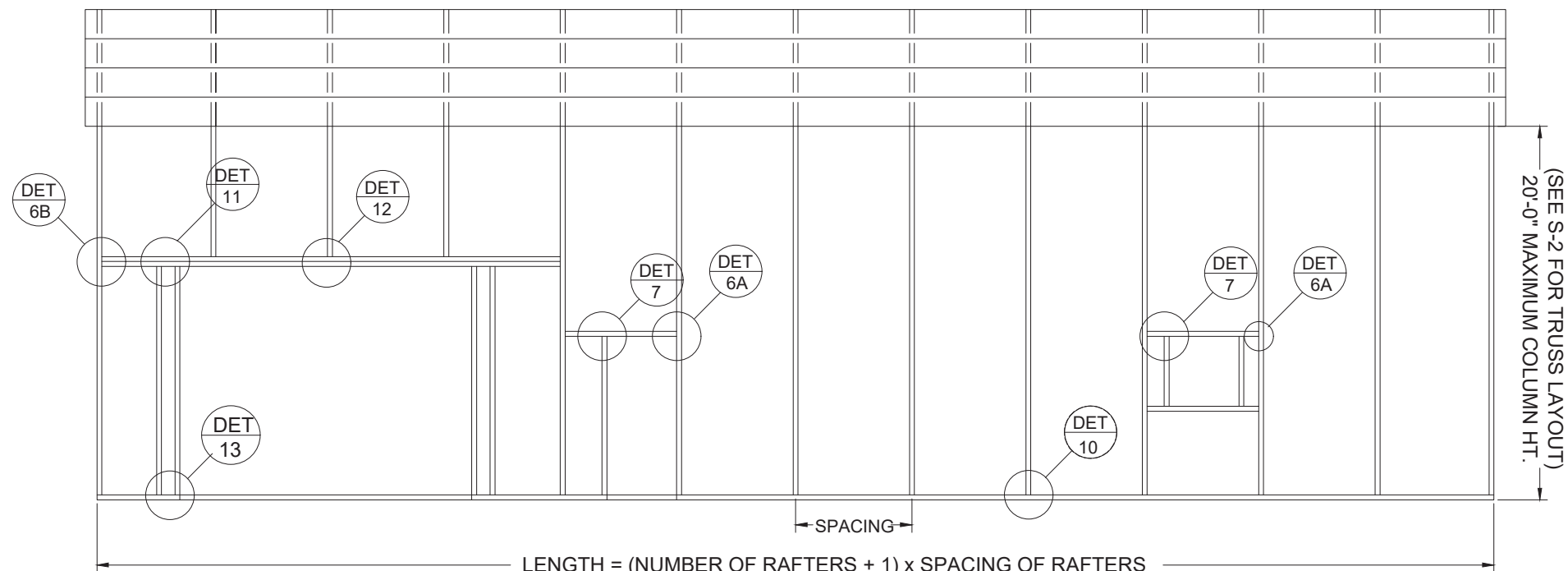

LENGTH = (NUMBER OF RAFTERS + 1) x SPACING OF RAFTERS
 SPACING = 5'-0" FOR WIND SPEEDS BETWEEN 110 MPH AND 140 MPH
 SPACING = 4'-0" FOR WIND SPEEDS BETWEEN 140 MPH AND 180 MPH

TYPICAL BOX EAVE RAFTER SIDE FRAMING SECTION
 SCALE: NTS

d:\ACE\ace - projects\elite-22047\Cadd\enclosed-building-3015.dwg, USER, 12/12/2022 1:49 PM

NO.	REVISIONS	DATE	DATE	2026.02.17	SUBMITTALS	DATE	PREPARED BY	CLIENT	SHEET TITLE	PROJECT	SHEET NO.
			DRAWN	SM			ADAM COLLINS ENGINEERING INC. CA# 31728 - P. 386.320.7400 - WWW.COLLINSENG.COM	ELITE METAL MANUFACTURING 10121 88TH TRACE	BOX EAVE RAFTER END WALL, SIDE WALL AND OPENING FRAMING	Brandon Reeves 1432 SE CR 349 Lake City, FL 32025	S-5
			DESIGNED	DMC							SCALE
			CHECKED	ATC							AS-SHOWN
			JOB No.	22047							

THIS DOCUMENT HAS BEEN DIGITALLY SIGNED AND SEALED BY ADAM T. COLLINS, P.E. ON 2026.02.17. PRINTED COPIES OF THIS DOCUMENT ARE NOT CONSIDERED SIGNED AND SEALED AND THE SIGNATURE MUST BE VERIFIED ON ANY ELECTRONIC COPIES.

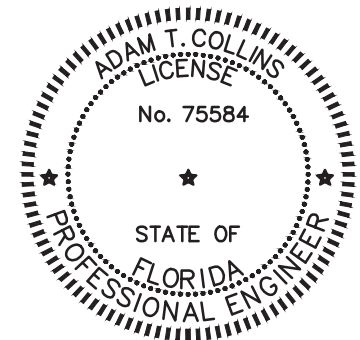

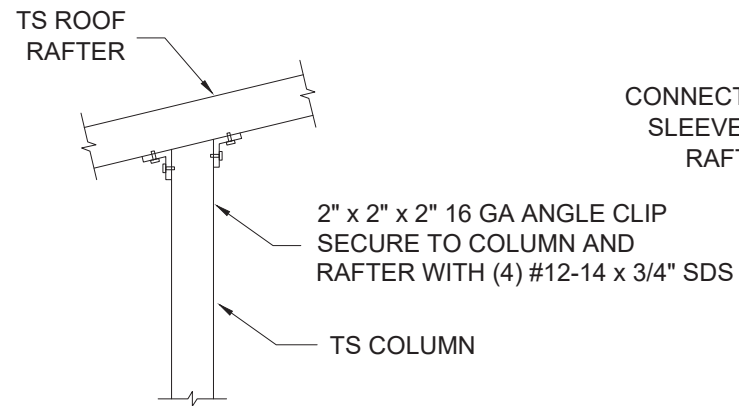

4 POST/RAFTER CONNECTION
SCALE: NTS

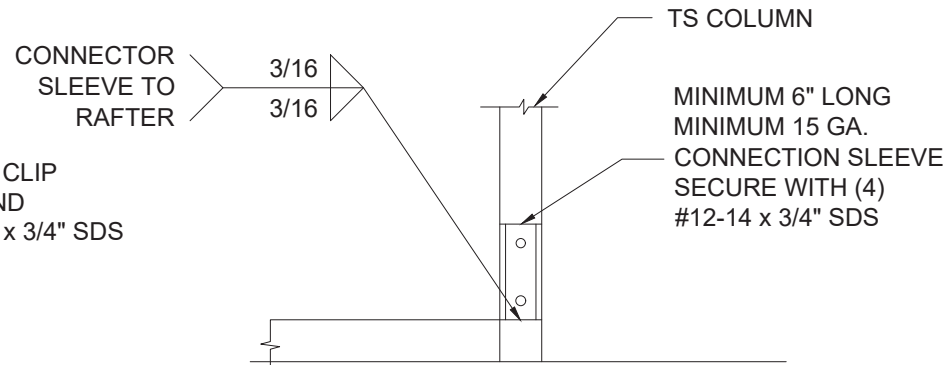

5 POST/BASE RAIL CONNECTION
SCALE: NTS

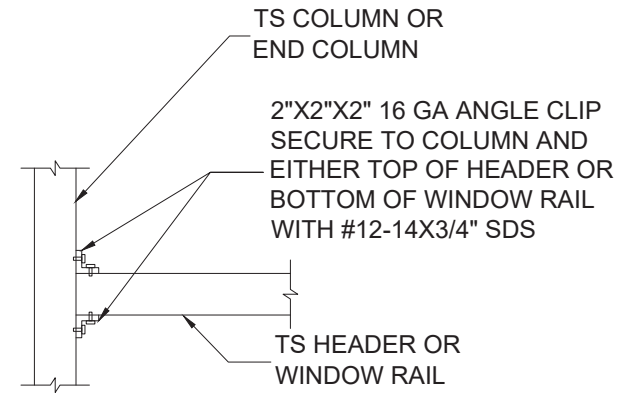

6A HEADER TO POST CONNECTION
SCALE: NTS

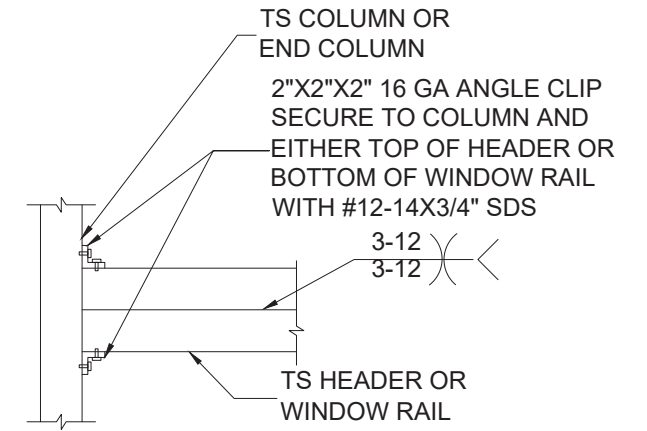

6B DOUBLE HEADER TO POST CONNECTION
SCALE: NTS

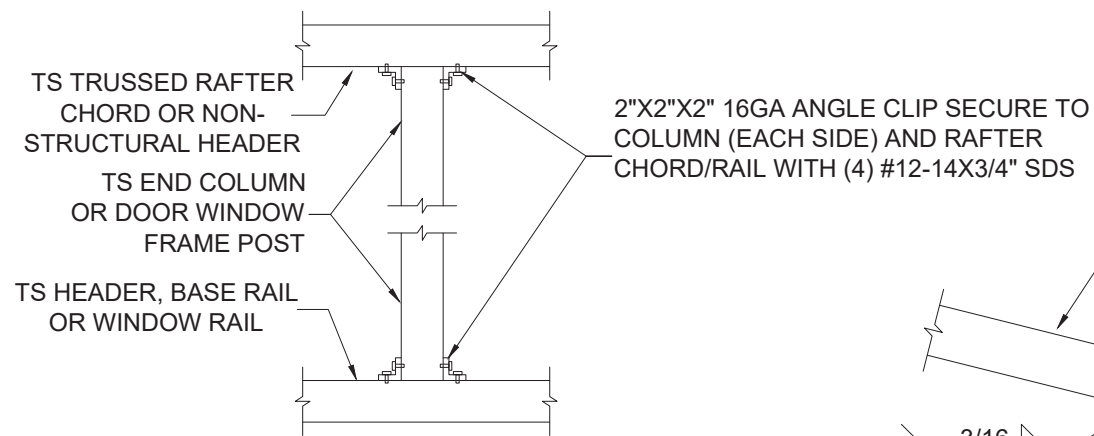

7 POST TO HEADER, BASE RAIL OR WINDOW RAIL CONNECTION
SCALE: NTS

NOTE AT ROLL-UP DOOR OPENINGS, COLUMN SHOULD BE FLUSH WITH RAIL END CLIP SIDE OPPOSITE THE OPENING

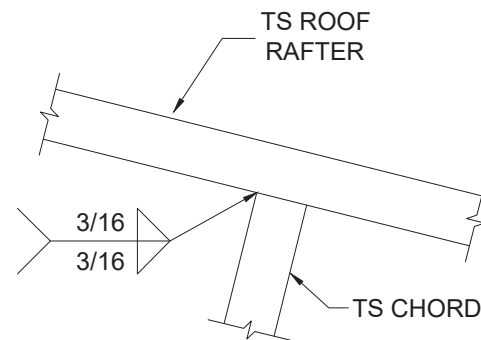

8 RAFTER TO CHORD CONNECTION
SCALE: NTS

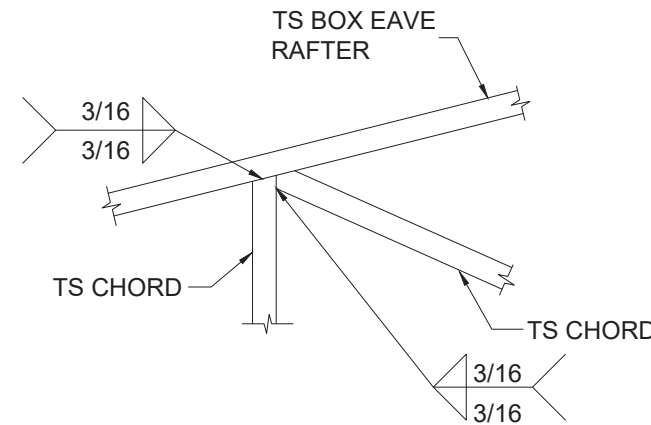

9 TRUSS POST AND CHORD TO RAFTER CONNECTION
SCALE: NTS

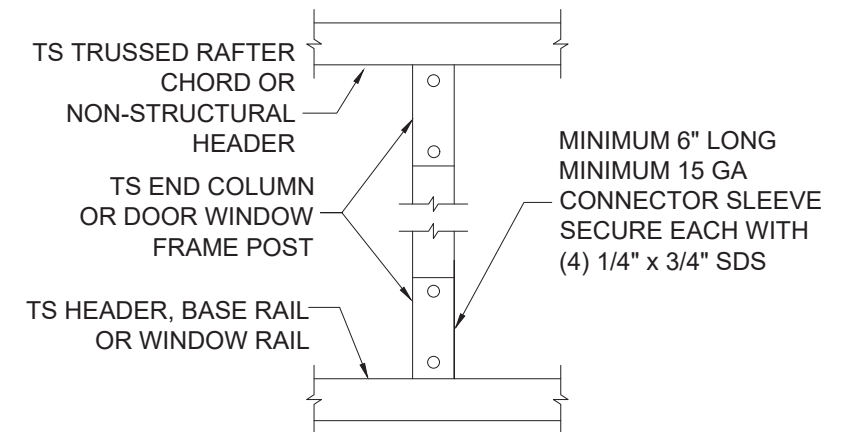

10 POST TO HEADER, BASE RAIL CONNECTION
SCALE: NTS

d:\ACE\ace - projects\elite-22047\Cadd\enclosed-building-3016.dwg, USER: 12/12/2022 1:49 PM

NO.	REVISIONS	DATE	DATE	2026.02.17	SUBMITTALS	DATE	PREPARED BY	CLIENT	SHEET TITLE	PROJECT	SHEET NO.
			DRAWN	SM			 ADAM COLLINS ENGINEERING INC. <small>CA# 31728 - P: 386.320.7400 - WWW.COLLINSENG.COM</small>	ELITE METAL MANUFACTURING 10121 88TH TRACE	CONNECTION DETAILS (2 OF 4)	Brandon Reeves 1432 SE CR 349 Lake City, FL 32025	S-6
			DESIGNED	DMC		SCALE					
			CHECKED	ATC		AS-SHOWN					
			JOB No.	22047							

THIS DOCUMENT HAS BEEN DIGITALLY SIGNED AND SEALED BY ADAM T. COLLINS, P.E. ON 2026.02.17. PRINTED COPIES OF THIS DOCUMENT ARE NOT CONSIDERED SIGNED AND SEALED AND THE SIGNATURE MUST BE VERIFIED ON ANY ELECTRONIC COPIES.

ADAM T. COLLINS
LICENSE
No. 75584
STATE OF FLORIDA
PROFESSIONAL ENGINEER

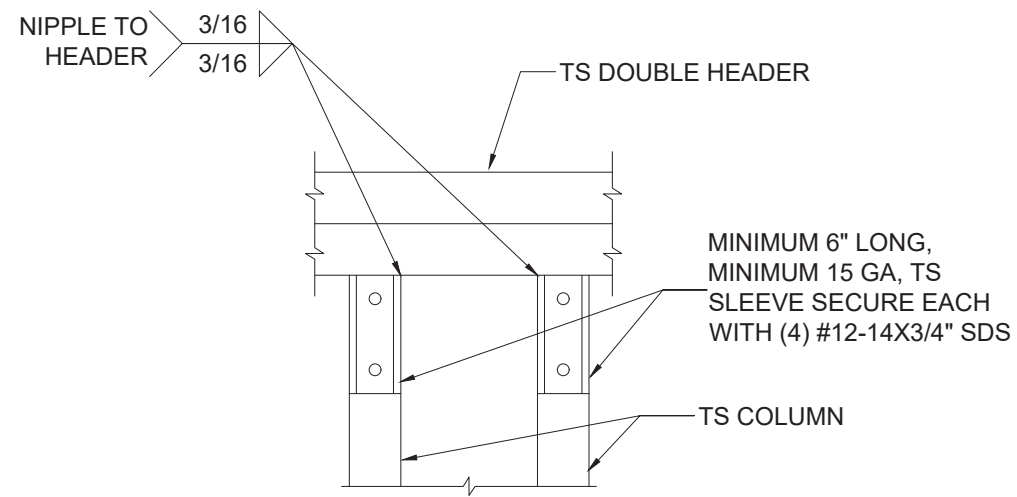

11 DOUBLE HEADER TO POST CONNECTION
SCALE: NTS

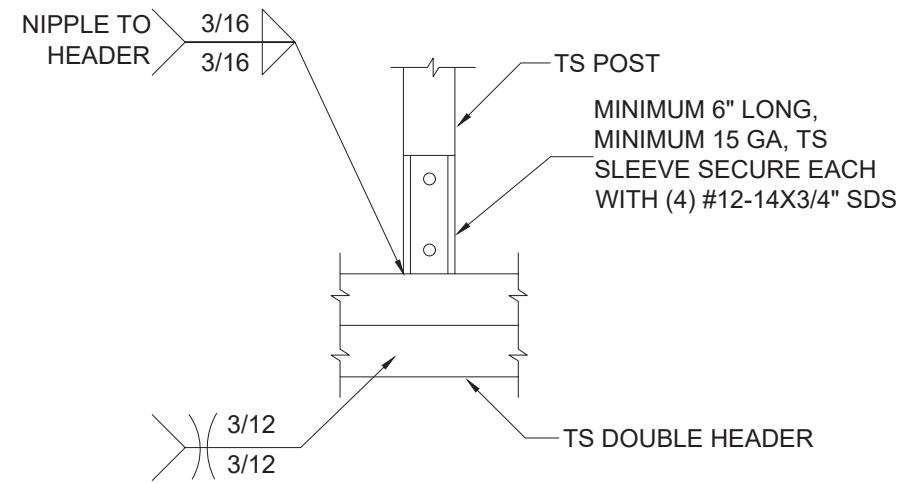

12 POST/DOUBLE HEADER CONNECTION
SCALE: NTS

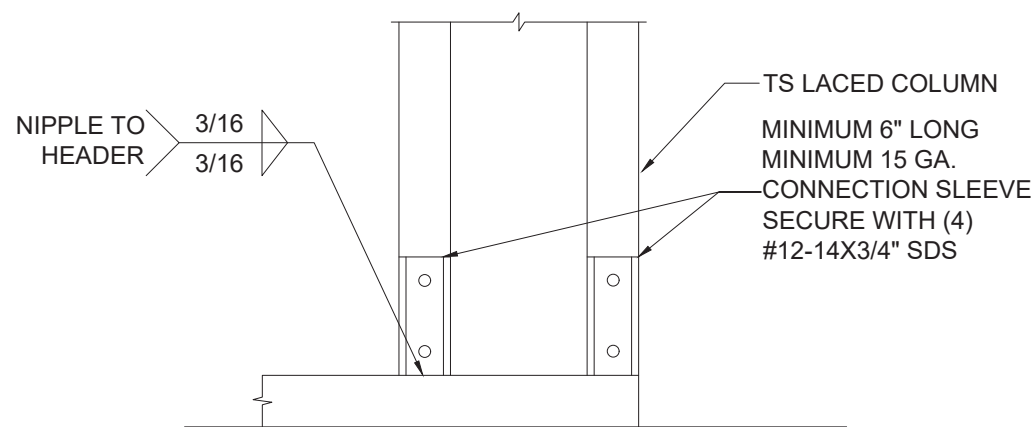

13A POST/BASE RAIL CONNECTION
SCALE: NTS

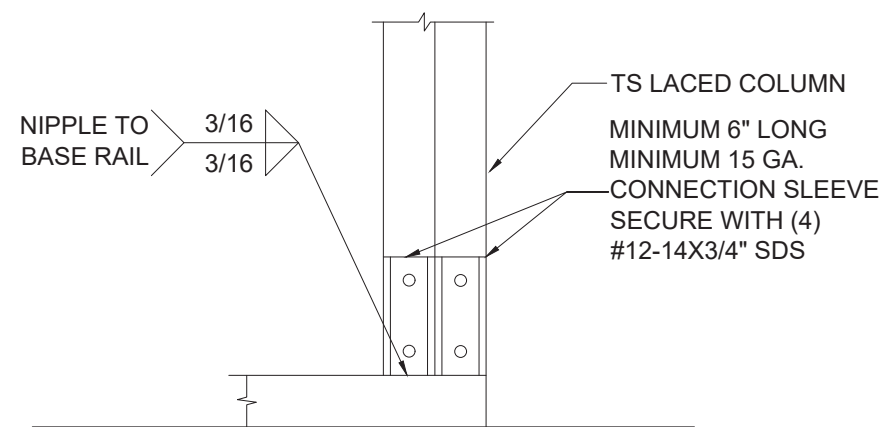

13B POST/BASE RAIL CONNECTION
SCALE: NTS

d:\ACE\ace - projects\elite-22047\Cadd\enclosed-building-3017.dwg, USER: 12/12/2022 1:49 PM

NO.	REVISIONS	DATE	DATE	2026.02.17	SUBMITTALS	DATE	PREPARED BY	CLIENT	SHEET TITLE	PROJECT	SHEET NO.
			DRAWN	SM			 ADAM COLLINS ENGINEERING INC. <small>CA# 31728 - P: 386.320.7400 - WWW.COLLINSENG.COM</small>	ELITE METAL MANUFACTURING 10121 88TH TRACE	CONNECTION DETAILS (3 OF 4)	Brandon Reeves 1432 SE CR 349 Lake City, FL 32025	S-7
			DESIGNED	DMC		SCALE					
			CHECKED	ATC		AS-SHOWN					
			JOB No.	22047							

THIS DOCUMENT HAS BEEN DIGITALLY SIGNED AND SEALED BY ADAM T. COLLINS, P.E. ON 2026.02.17. PRINTED COPIES OF THIS DOCUMENT ARE NOT CONSIDERED SIGNED AND SEALED AND THE SIGNATURE MUST BE VERIFIED ON ANY ELECTRONIC COPIES.

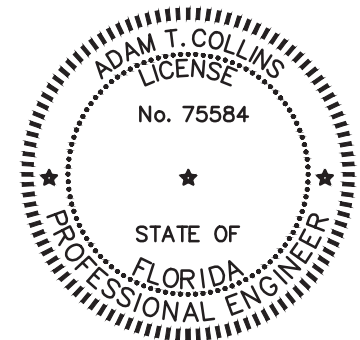

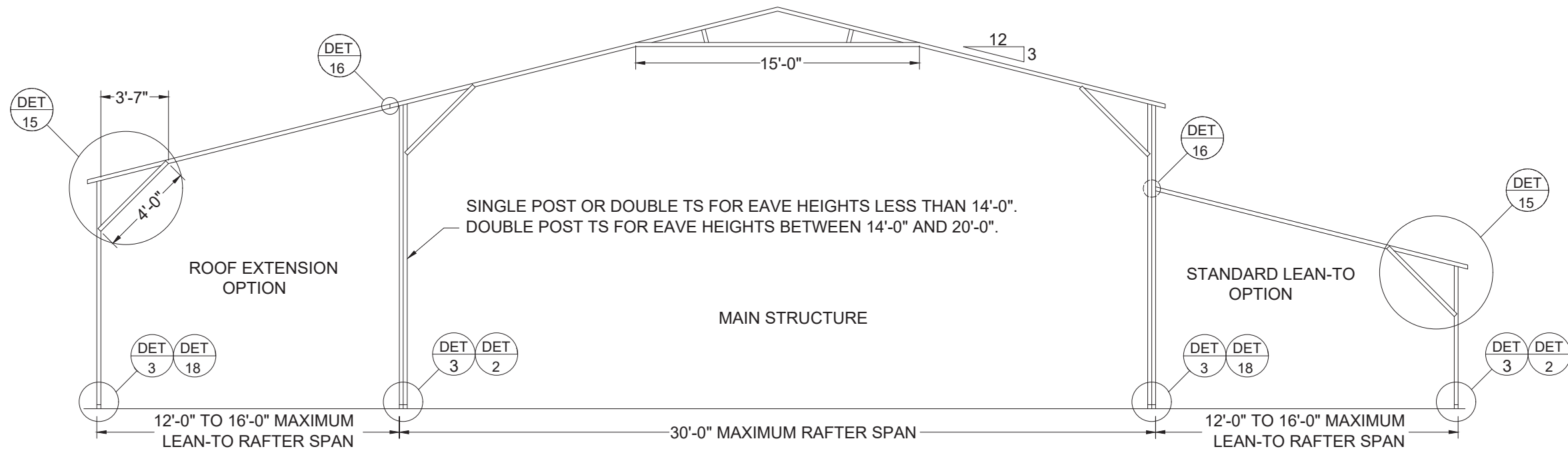

TYPICAL BOX EAVE RAFTER LEAN-TO OPTIONS FRAMING SECTION
SCALE: NTS

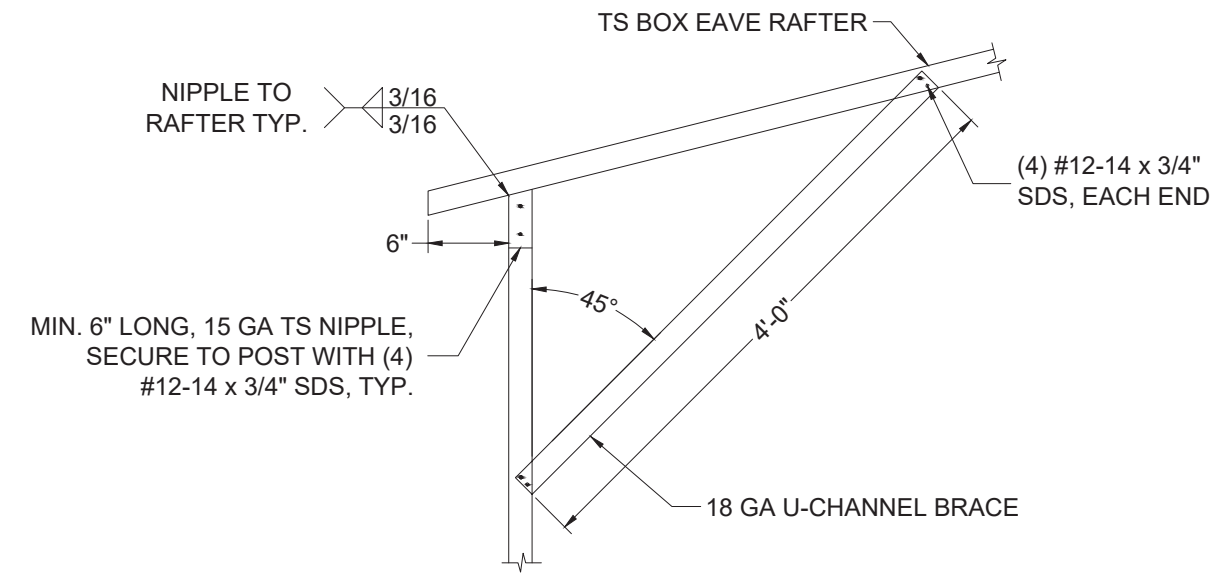

LEAN-TO RAFTER/CORNER POST CONNECTION
SCALE: NTS

THIS DOCUMENT HAS BEEN DIGITALLY SIGNED AND SEALED BY ADAM T. COLLINS, P.E. ON 2026.02.17. PRINTED COPIES OF THIS DOCUMENT ARE NOT CONSIDERED SIGNED AND SEALED AND THE SIGNATURE MUST BE VERIFIED ON ANY ELECTRONIC COPIES.

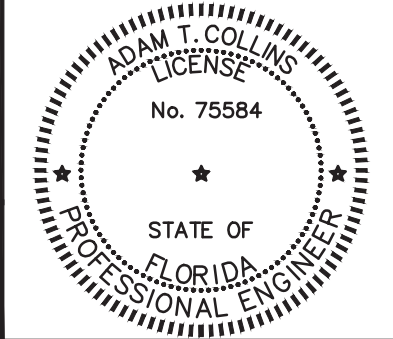

d:\ACE\ace - projects\elite-22047\Cadd\enclosed-building-3018.dwg, USER, 12/12/2022 1:50 PM

NO.	REVISIONS	DATE	DATE	2026.02.17	SUBMITTALS	DATE	PREPARED BY	CLIENT	SHEET TITLE	PROJECT	SHEET NO.
			DRAWN	SM			ADAM COLLINS ENGINEERING INC. CA# 31728 - P. 386.320.7400 - WWW.COLLINSENG.COM	ELITE METAL MANUFACTURING 10121 88TH TRACE	BOX EAVE RAFTER LEAN TO OPTIONS	Brandon Reeves 1432 SE CR 349 Lake City, FL 32025	S-8
			DESIGNED	DMC							SCALE
			CHECKED	ATC							AS-SHOWN
			JOB No.	22047							

26 OR 29 GA. METAL ROOF PANELS
FASTENED TO BOW FRAME WITH 1/4" X 3/4" SDF'S
WITH CONTROL SEAL WASHER.
(SEE TABLE 1 FOR FASTENER SPACING)

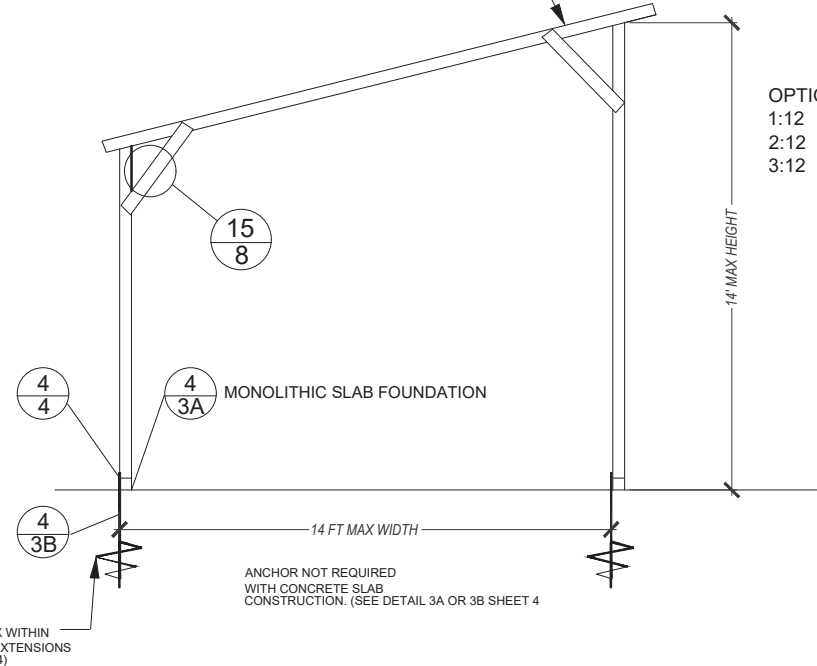

14 FT MAX WIDTH FREESTANDING LEAN-TO
SCALE: NTS

26 OR 29 GA. GALVANIZED METAL ROOF PANELS
FASTENED TO RAFTER/BOW FRAME WITH
#12-14 X 3/4" SDF'S WITH CONTROL SEAL WASHER
(SEE TABLE 1 FOR FASTENER SPACING)

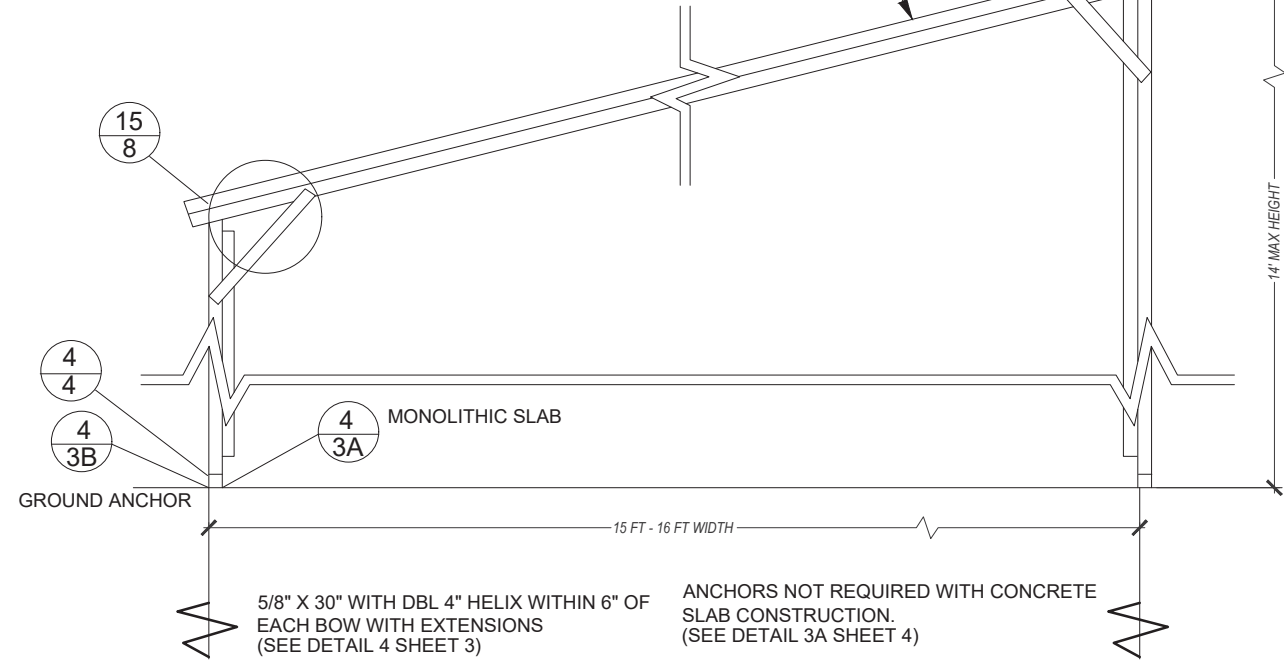

15 FT - 16 FT WIDTH FREESTANDING LEAN-TO LEAN-TO
SCALE: NTS

26 OR 29 GA. GALVANIZED METAL ROOF PANELS
FASTENED TO RAFTER/BOW FRAME WITH
#12-14 X 3/4" SDF'S WITH CONTROL SEAL WASHER
(SEE TABLE 1 FOR FASTENER SPACING)

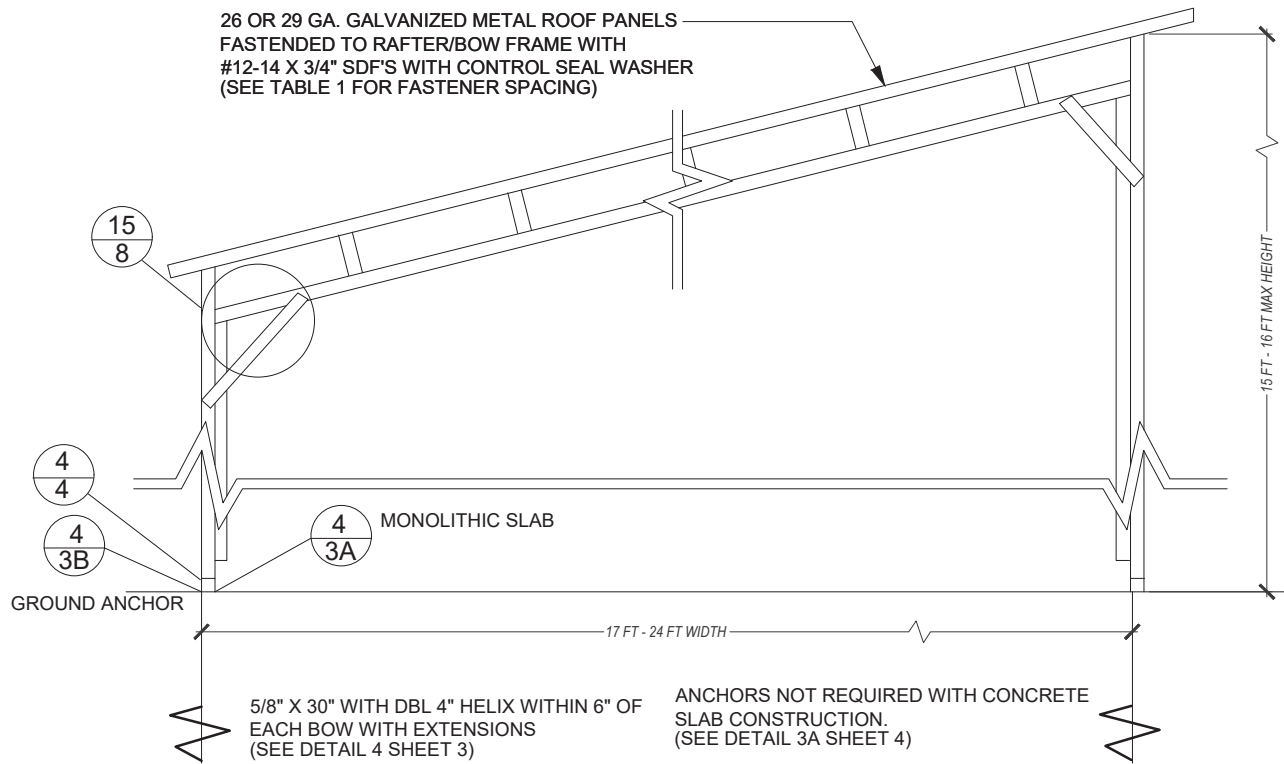

17 FT - 24 FT WIDTH FREESTANDING LEAN-TO LEAN-TO
SCALE: NTS

26 OR 29 GA. GALVANIZED METAL ROOF PANELS
FASTENED TO RAFTER/BOW FRAME WITH
#12-14 X 3/4" SDF'S WITH CONTROL SEAL WASHER
(SEE TABLE 1 FOR FASTENER SPACING)

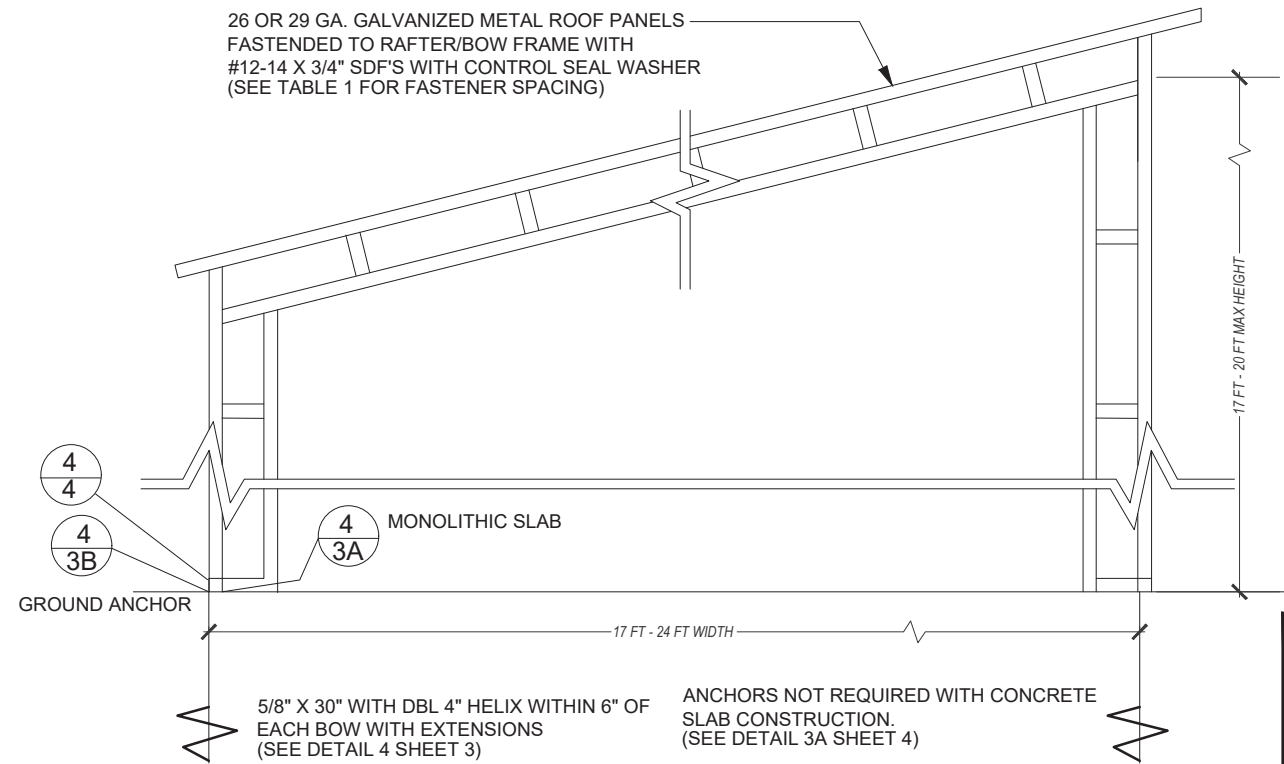

17 FT - 24 FT WIDTH FREESTANDING LEAN-TO LEAN-TO
SCALE: NTS

s:\ace dropbox\PROJECTS\lite-22047\support\30-enclosed-building\Enclosed-Building-30.dwg USER: 9/22/2023 12:37 PM

NO.	REVISIONS	DATE	DATE	#	SUBMITTALS	DATE	PREPARED BY	CLIENT	SHEET TITLE	PROJECT	SHEET NO.
				20201027			ADAM COLLINS	ELITE METAL MANUFACTURING	FREESTANDING BOX EAVE RAFTER LEAN-TO OPTIONS	Brandon Reeves	S-9
							SM	10121 88TH TRACE		1432 SE CR 349	SCALE
							DMC			Lake City, FL 32025	AS-SHOWN
							ATC				
							JOB No. 22047				



THIS DOCUMENT HAS BEEN DIGITALLY SIGNED AND SEALED BY ADAM T. COLLINS, P.E. ON 2026.02.17. PRINTED COPIES OF THIS DOCUMENT ARE NOT CONSIDERED SIGNED AND SEALED AND THE SIGNATURE MUST BE VERIFIED ON ANY ELECTRONIC COPIES.

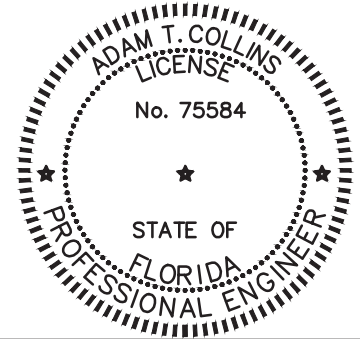

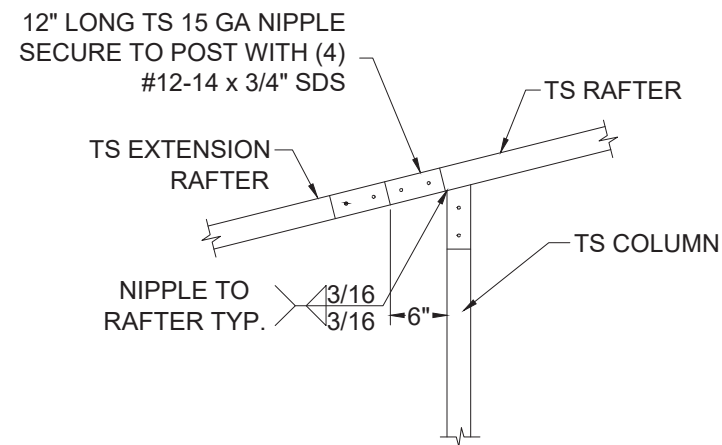

16A SIDE EXTENSION RAFTER/POST CONNECTION
 RAFTER SPAN LESS THAN 12'-0"
 SCALE: NTS

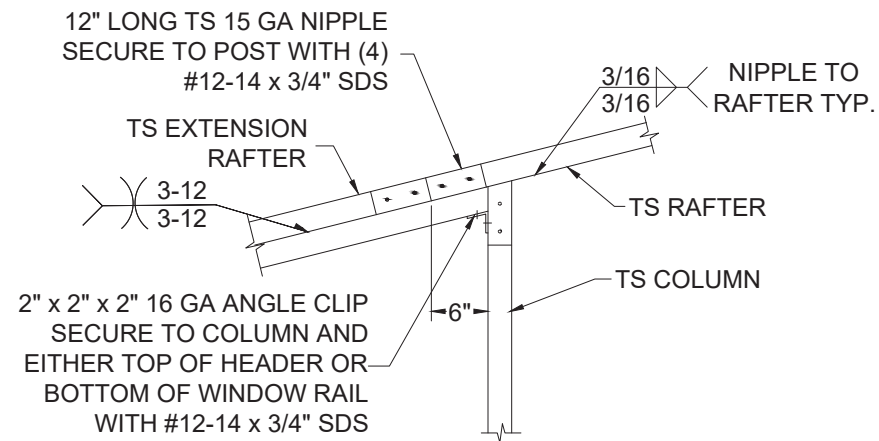

16B SIDE EXTENSION RAFTER/POST CONNECTION
 RAFTER SPAN BETWEEN 12'-0" AND 16'-0"
 SCALE: NTS

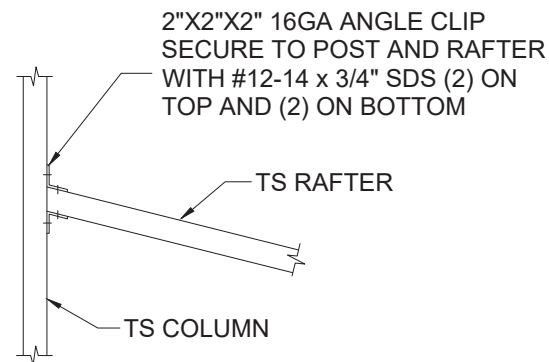

17A LEAN TO RAFTER/COLUMN CONNECTION
 RAFTER SPAN LESS THAN 12'-0"
 SCALE: NTS

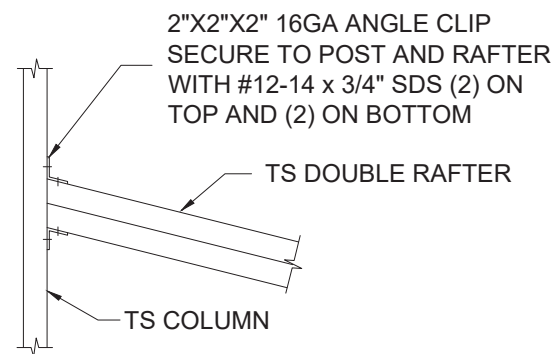

17B LEAN TO RAFTER/COLUMN CONNECTION
 RAFTER SPAN BETWEEN 12'-0" AND 16'-0"
 SCALE: NTS

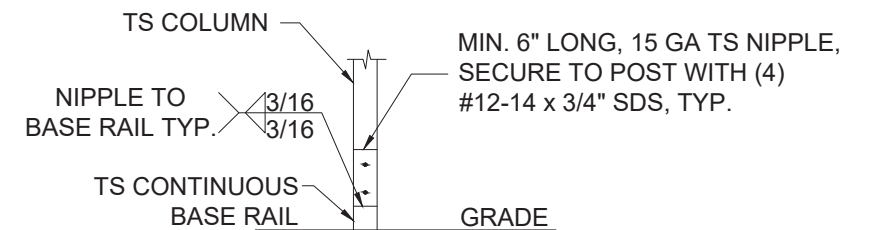

18 LEAN-TO POST CONNECTION
 SCALE: NTS

d:\ACE\ace - projects\elite-22047\Cadd\enclosed-building-3019.dwg, USER: 12/12/2022 1:50 PM

NO.	REVISIONS	DATE	DATE	2026.02.17	SUBMITTALS	DATE	PREPARED BY	CLIENT	SHEET TITLE	PROJECT	SHEET NO.
			DRAWN	SM			ADAM COLLINS ENGINEERING INC. <small>CA# 31728 - P. 386.320.7400 - WWW.COLLINSENG.COM</small>	ELITE METAL MANUFACTURING 10121 88TH TRACE	CONNECTION DETAILS (4 OF 4)	Brandon Reeves 1432 SE CR 349 Lake City, FL 32025	S-10
			DESIGNED	DMC							SCALE
			CHECKED	ATC							AS-SHOWN
			JOB No.	22047							

THIS DOCUMENT HAS BEEN DIGITALLY SIGNED AND SEALED BY ADAM T. COLLINS, P.E. ON 2026.02.17. PRINTED COPIES OF THIS DOCUMENT ARE NOT CONSIDERED SIGNED AND SEALED AND THE SIGNATURE MUST BE VERIFIED ON ANY ELECTRONIC COPIES.

ADAM T. COLLINS
 LICENSE
 No. 75584
 STATE OF
 FLORIDA
 PROFESSIONAL ENGINEER

d:\ACE\ace - projects\elite-22047\Cadd\enclosed-building-30\10.dwg, USER, 12/12/2022 1:50 PM

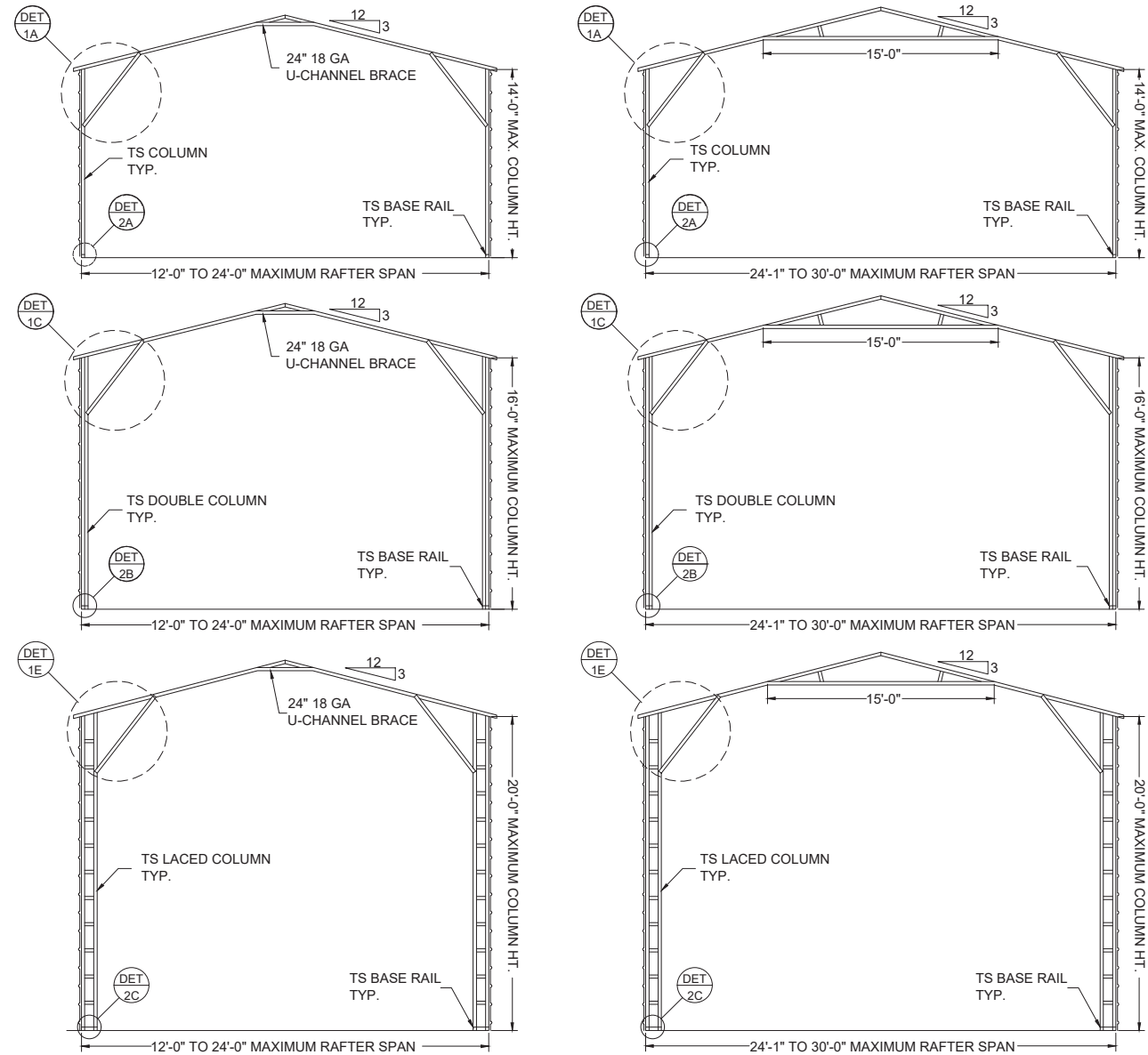

BOX EAVE FRAME
SCALE: NTS

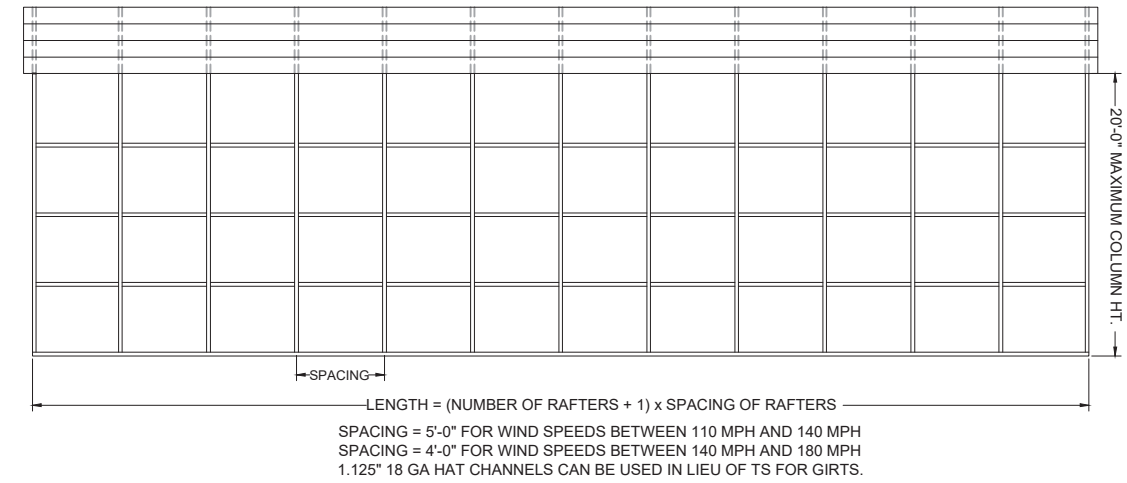

TYPICAL SIDE FRAME SECTION
SCALE: NTS

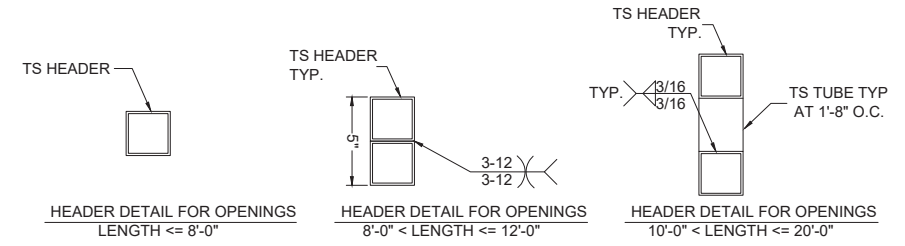

SIDE WALL OPTION HEADER
SCALE: NTS

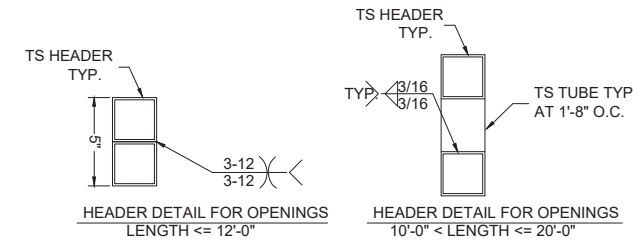

END WALL OPTION HEADER
SCALE: NTS

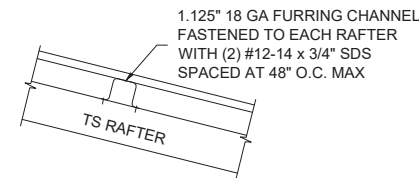

PANEL ATTACHMENT
(ALTERNATE FOR VERTICAL ROOF PANELS)
SCALE: NTS

NO.	REVISIONS	DATE	DATE	2026.02.17	SUBMITTALS	DATE	PREPARED BY	CLIENT	SHEET TITLE	PROJECT	SHEET NO.
			DRAWN	SM			ADAM COLLINS ENGINEERING INC. CA# 31728 - P: 386.320.7400 - WWW.COLLINSENG.COM	ELITE METAL MANUFACTURING 10121 88TH TRACE	BOX EAVE RAFTER VERTICAL ROOF-SIDING OPTION	Brandon Reeves 1432 SE CR 349 Lake City, FL 32025	S-11
		DESIGNED	DMC			SCALE					
		CHECKED	ATC			AS-SHOWN					
		JOB No.	22047								

THIS DOCUMENT HAS BEEN DIGITALLY SIGNED AND SEALED BY ADAM T. COLLINS, P.E. ON 2026.02.17. PRINTED COPIES OF THIS DOCUMENT ARE NOT CONSIDERED SIGNED AND SEALED AND THE SIGNATURE MUST BE VERIFIED ON ANY ELECTRONIC COPIES.

ADAM T. COLLINS
LICENSE
No. 75584
STATE OF
FLORIDA
PROFESSIONAL ENGINEER

GENERAL NOTES

MINIMUM SOIL BEARING CAPACITY: 1500 PSF.
 CONCRETE STRENGTH: 3000 PSI @ 28 DAYS

REINFORCING STEEL

1. REBAR SHALL BE ASTM A615 GRADE 60
2. SLAB REINFORCEMENT = WELDED WIRE FABRIC PER ASTM A185 OR FIBERGLASS FIBER REINFORCEMENT
3. CONCRETE COVER SHALL BE
 - 3.1. 3" WHERE EXPOSED TO SOIL OR WATER.
 - 3.2. 2" EVERYWHERE ELSE.
4. REBAR SHALL BE BENT WITHOUT HEATING.
5. MINIMUM BEND = 6 X BAR DIAMETER
6. REINFORCEMENT PARTIALLY EMBEDDED IN CONCRETE SHALL NOT BE FIELD BENT.

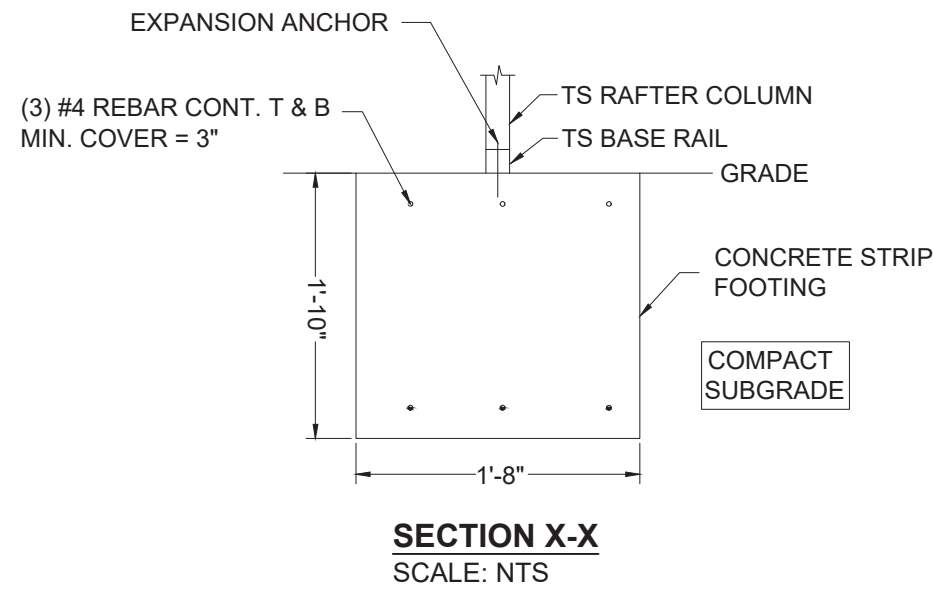
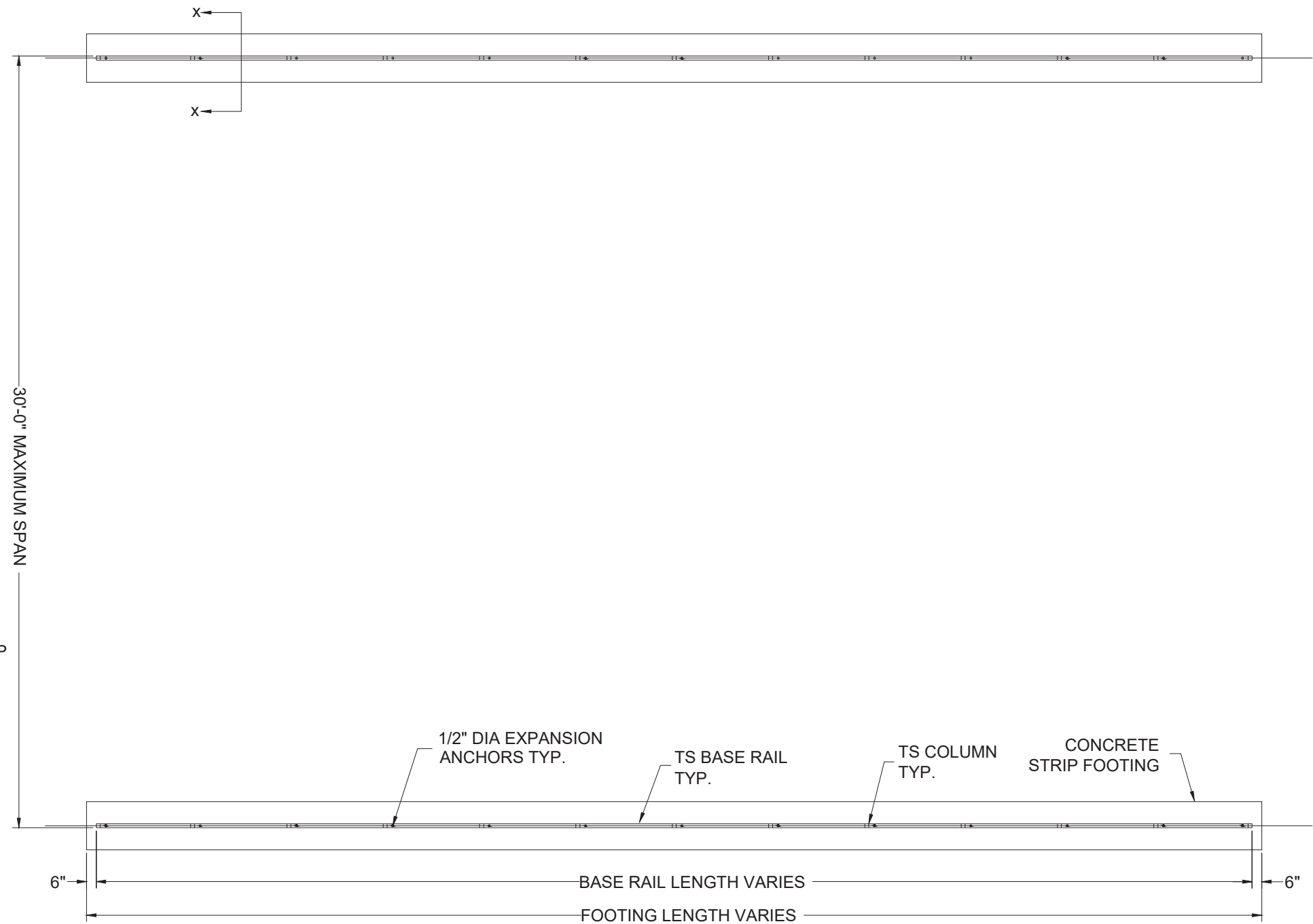

CONCRETE STRIP FOOTING PLAN
 SCALE: NTS

THIS DOCUMENT HAS BEEN DIGITALLY SIGNED AND SEALED BY ADAM T. COLLINS, P.E. ON 2026.02.17. PRINTED COPIES OF THIS DOCUMENT ARE NOT CONSIDERED SIGNED AND SEALED AND THE SIGNATURE MUST BE VERIFIED ON ANY ELECTRONIC COPIES.

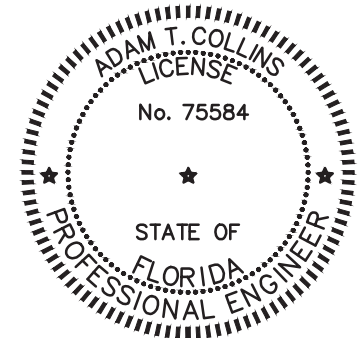

d:\ACE\ace - projects\elite-22047\Cadd\enclosed-building-30\11.dwg, USER, 12/12/2022, 1:50 PM

NO.	REVISIONS	DATE	DATE	2026.02.17	SUBMITTALS	DATE	PREPARED BY	CLIENT	SHEET TITLE	PROJECT	SHEET NO.
			DRAWN	SM			ADAM COLLINS ENGINEERING INC. CA# 31728 - P: 386.320.7400 - WWW.COLLINSENG.COM	ELITE METAL MANUFACTURING 10121 88TH TRACE	OPTIONAL CONCRETE STRIP FOOTING	Brandon Reeves 1432 SE CR 349 Lake City, FL 32025	S-12
			DESIGNED	DMC		SCALE					
			CHECKED	ATC		AS-SHOWN					
			JOB No.	22047							

HELIX ANCHOR NOTES

1. USE MINIMUM (2) 4" HELICES WITH 30" EMBEDMENT FOR THE FOLLOWING SOILS:
 - 1.1. VERY DENSE AND/OR CEMENTED SANDS
 - 1.2. COARSE GRAVEL AND COBBLES
 - 1.3. CALICHE
 - 1.4. PRELOADED SILTS AND CLAYS
 - 1.5. CORALS
 - 1.6. MEDIUM DENSE COARSE SANDS
 - 1.7. SANDY GRAVEL
 - 1.8. VERY STIFF SILTS AND CLAYS
2. USE MINIMUM (2) 6" HELICES WITH MINIMUM 50" EMBEDMENT FOR
 - 2.1. LOOSE TO MEDIUM DENSE SANDS
 - 2.2. FIRM TO STIFF CLAYS AND SILTS
 - 2.3. ALLUVIAL FILL
3. USE MINIMUM (2) 8" HELICES WITH MINIMUM 60" EMBEDMENT.
 - 3.1. FOR VERY LOOSE TO MEDIUM DENSE SANDS
 - 3.2. FIRM TO STIFFER CLAYS AND SILTS
 - 3.3. ALLUVIAL FILL,

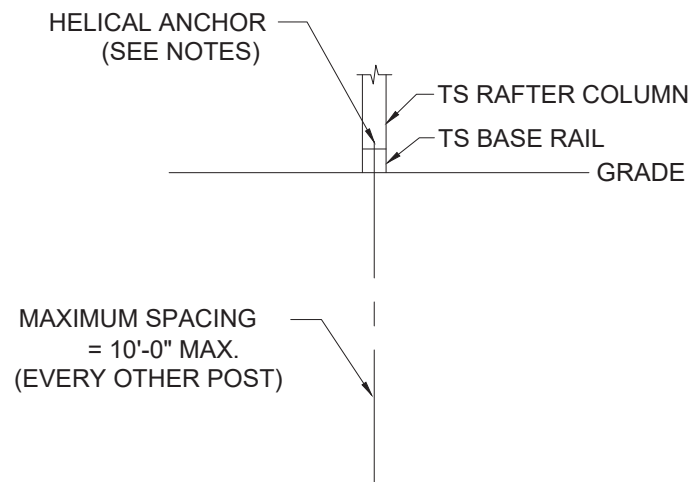
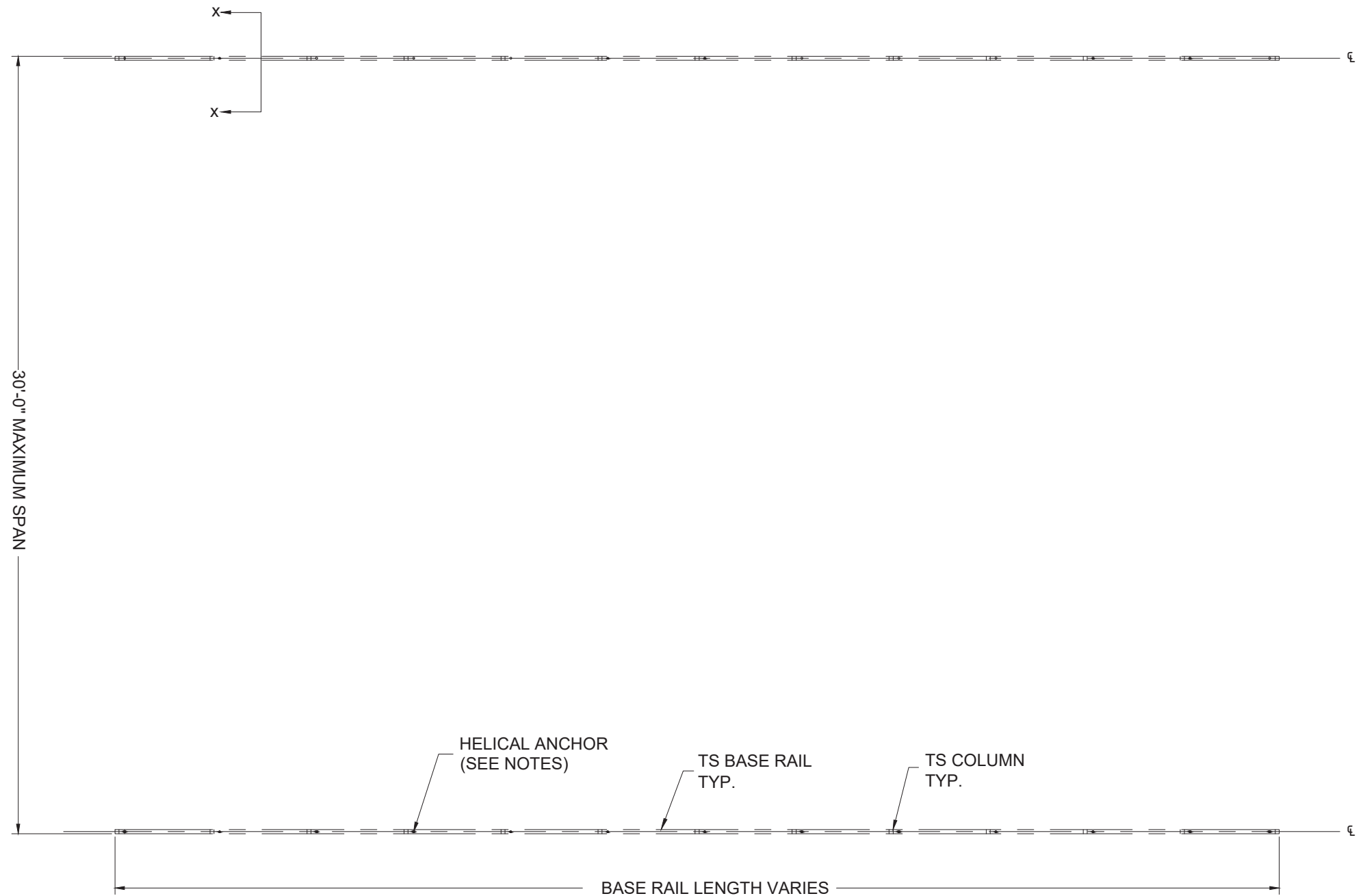

SECTION X-X
SCALE: NTS

BASE RAIL PLAN
SCALE: NTS

THIS DOCUMENT HAS BEEN DIGITALLY SIGNED AND SEALED BY ADAM T. COLLINS, P.E. ON 2026.02.17. PRINTED COPIES OF THIS DOCUMENT ARE NOT CONSIDERED SIGNED AND SEALED AND THE SIGNATURE MUST BE VERIFIED ON ANY ELECTRONIC COPIES.

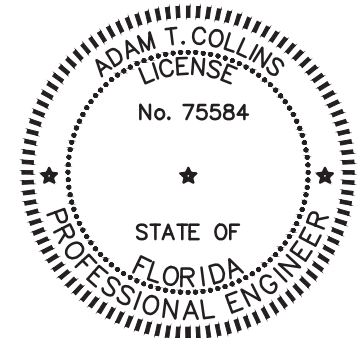

d:\ACE\ace - projects\elite-22047\Cadd\enclosed-building-30'x12.dwg, USER, 12/12/2022, 1:50 PM

NO.	REVISIONS	DATE	DATE	2026.02.17	SUBMITTALS	DATE	PREPARED BY	CLIENT	SHEET TITLE	PROJECT	SHEET NO.
			DRAWN	SM			<p>ADAM COLLINS ENGINEERING INC. CA# 31728 - P. 386.320.7400 - WWW.COLLINSENG.COM</p>	ELITE METAL MANUFACTURING 10121 88TH TRACE	OPTIONAL HELICAL ANCHORING DETAIL	Brandon Reeves 1432 SE CR 349 Lake City, FL 32025	S-13
			DESIGNED	DMC		SCALE					
			CHECKED	ATC		AS-SHOWN					
			JOB No.	22047							