



DEPARTMENT OF REGULATORY AND ECONOMIC RESOURCES (RER)
BOARD AND CODE ADMINISTRATION DIVISION

NOTICE OF ACCEPTANCE (NOA)

MIAMI-DADE COUNTY
PRODUCT CONTROL SECTION
11805 SW 26 Street, Room 208
Miami, Florida 33175-2474
T (786) 315-2590 F (786) 315-2599
www.miamidade.gov/economy

GAF
1 Campus Drive
Parsippany, NJ 07054

SCOPE:

This NOA is being issued under the applicable rules and regulations governing the use of construction materials. The documentation submitted has been reviewed and accepted by Miami-Dade County RER - Product Control Section to be used in Miami Dade County and other areas where allowed by the Authority Having Jurisdiction (AHJ).

This NOA shall not be valid after the expiration date stated below. The Miami-Dade County Product Control Section (In Miami Dade County) and/or the AHJ (in areas other than Miami Dade County) reserve the right to have this product or material tested for quality assurance purposes. If this product or material fails to perform in the accepted manner, the manufacturer will incur the expense of such testing and the AHJ may immediately revoke, modify, or suspend the use of such product or material within their jurisdiction. RER reserves the right to revoke this acceptance, if it is determined by Miami-Dade County Product Control Section that this product or material fails to meet the requirements of the applicable building code.

This product is approved as described herein, and has been designed to comply with the Florida Building Code including the High Velocity Hurricane Zone of the Florida Building Code.

DESCRIPTION: GAF Timberline® Natural Shadow®, Timberline® NS, Timberline® American Harvest®, Timberline® AH, Timberline HDZ®, Timberline® CS and Fortitude®, Timberline® UHDZ™ Shingles

LABELING: Each unit shall bear a permanent label with the manufacturer's name or logo, city, state and following statement: "Miami-Dade County Product Control Approved", unless otherwise noted herein.

RENEWAL of this NOA shall be considered after a renewal application has been filed and there has been no change in the applicable building code negatively affecting the performance of this product.

TERMINATION of this NOA will occur after the expiration date or if there has been a revision or change in the materials, use, and/or manufacture of the product or process. Misuse of this NOA as an endorsement of any product, for sales, advertising or any other purposes shall automatically terminate this NOA. Failure to comply with any section of this NOA shall be cause for termination and removal of NOA.

ADVERTISEMENT: The NOA number preceded by the words Miami-Dade County, Florida, and followed by the expiration date may be displayed in advertising literature. If any portion of the NOA is displayed, then it shall be done in its entirety.

INSPECTION: A copy of this entire NOA shall be provided to the user by the manufacturer or its distributors and shall be available for inspection at the job site at the request of the Building Official.

This NOA revises NOA #21-1209.01 and consists of pages 1 through 6.
The submitted documentation was reviewed by Alex Tigera.



NOA No.: 22-1221.04
Expiration Date: 02/21/27
Approval Date: 09/07/23
Page 1 of 6

ROOFING ASSEMBLY APPROVAL

Category:	Roofing
Sub-Category:	Asphalt Shingles
Materials:	Laminate
Deck Type:	Wood

SCOPE

This approves GAF Timberline® Natural Shadow®, Timberline® NS, Timberline American® Harvest®, Timberline® AH, Timberline HDZ®, Timberline® CS and Fortitude® Shingles as manufactured by GAF as described in this Notice of Acceptance.

PRODUCT DESCRIPTION

<u>Product</u>	<u>Dimensions</u>	<u>Test Specifications</u>	<u>Product Description</u>
GAF Timberline® Natural Shadow® and Timberline® NS <i>Manufacturing</i> <i>Locations #1, 2, 3, 4, 5, 6, 7</i>	13 1/4" x 39 3/8"	TAS 110	Fiberglass reinforced heavy weight asphalt roof shingle, with a laminate profile
GAF Timberline® American Harvest® <i>Manufacturing</i> <i>Locations #2, 4, 6</i>	13 1/4" x 39 3/8"	TAS 110	Fiberglass reinforced heavy weight asphalt roof shingle, with a laminate profile
GAF Timberline® AH <i>Manufacturing</i> <i>Locations #2, 4, 6, 9</i>	13 1/4" x 39 3/8"	TAS 110	Fiberglass reinforced heavy weight asphalt roof shingle, with a laminate profile
GAF Timberline HDZ® <i>Manufacturing</i> <i>Locations #1, 2, 3, 4, 5, 6, 7, 8, 9, 10</i>	13 1/4" x 39 3/8"	TAS 110	Fiberglass reinforced heavy weight asphalt roof shingle, with a laminate profile
GAF Fortitude® <i>Manufacturing</i> <i>Location #4</i>	13 1/4" x 39 3/8"	TAS 110	Fiberglass reinforced heavy weight asphalt roof shingle, with a laminate profile
GAF Timberline® CS <i>Manufacturing</i> <i>Location #9</i>	13 1/4" x 39 3/8"	TAS 110	Fiberglass reinforced heavy weight asphalt roof shingle, with a laminate profile
GAF Timberline® UHDZ™ <i>Manufacturing Location #2, 4, 6, 8</i>	13 1/4" x 39 3/8"	TAS 110	Fiberglass reinforced heavy weight asphalt roof shingle, with a laminate profile



MANUFACTURING LOCATION

1. Tampa, FL
2. Michigan City, IN
3. Baltimore, MD
4. Myerstown, PA
5. Ennis, TX
6. Tuscaloosa, AL
7. Dallas, TX
8. Shafter, CA
9. Fontana, CA
10. Minneapolis, MN

EVIDENCE SUBMITTED

<u>Test Agency</u>	<u>Test Identifier</u>	<u>Test Name/Report</u>	<u>Date</u>
Underwriters Laboratories, LLC	ASTM D3462	4790488380	08/22/22
	ASTM D3462	4788932264	12/13/19
	ASTM D3462	4788717529	01/31/19
	ASTM D3462	4787344101	07/25/16
	TAS 107	4789225984	11/1/19
	TAS 107	4788717529	01/31/19
	TAS 107	01NK45803	04/13/94
	TAS 107	06NK05159	08/09/06
	TAS 107	04NK04273	02/20/04
	TAS 107	05CA42840	11/11/05
	TAS 107	02NK41811	11/11/02
	TAS 107	03CA35209	10/17/03
	TAS 107	04CA13850	08/30/04
	PRI Asphalt Technologies, Inc.	TAS 100	GAF-912-02-01
TAS 100		GAF-044-02-01	01/13/04
TAS 100		GAF-098-02-01	11/08/05
TAS 100		GAF-101-02-01	11/09/05
TAS 100		GAF-116-02-02	03/23/06
TAS-100		ELK-083-02-01	10/16/02
		ELK-084-02-01	10/15/02
		ELK-085-02-01	10/14/02
		ELK-086-02-01	10/24/02
		ELK-087-02-01	10/21/02
		ELK-088-02-01	10/16/02
	ELK-107-02-01	10/09/03	
	ELK-108-02-01	10/09/03	
	ELK-109-02-01	10/09/03	



LIMITATIONS

1. Fire classification is not part of this acceptance; refer to a current Approved Roofing Materials Directory for fire ratings of this product.
2. Shall not be installed on roof mean heights in excess of 33 ft.
3. All products listed herein shall have a quality assurance audit in accordance with the Florida Building Code and Rule 61G20-3 of the Florida Administrative Code.

INSTALLATION

1. Shingles shall be installed in compliance with Roofing Application Standard RAS 115.
2. Flashing shall be in accordance with Roofing Application Standard RAS 115
3. The manufacturer shall provide clearly written application instructions.
4. Exposure and course layout shall be in compliance with Detail 'A', attached.
5. Nailing shall be in compliance with Detail 'B', attached.

LABELING

Shingles shall bear the imprint or identifiable marking of the manufacturer's name or logo, city and state of manufacturing facility, and following statement: "Miami-Dade County Product Control Approved" or the Miami-Dade County Product Control Seal as shown below.



BUILDING PERMIT REQUIREMENTS

1. Application for building permit shall be accompanied by copies of the following:
 - 1.1 This Notice of Acceptance.
 - 1.2 Any other documents required by the Building Official or the applicable code in order to properly evaluate the installation of this system.



DETAIL A COURSE LAYOUT

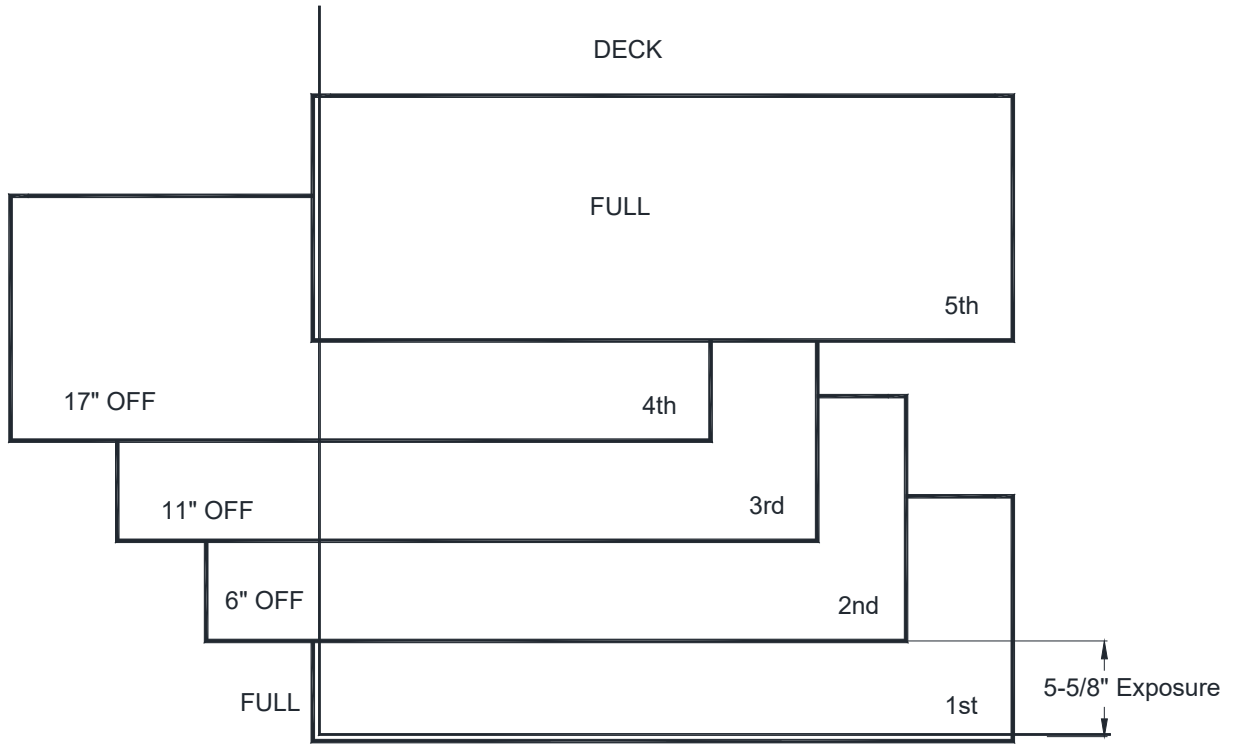

DETAIL B
OVERALL DIMENSIONS AND NAILING PATTERN
FOR GAF TIMBERLINE® NATURAL SHADOW® AND TIMBERLINE® NS

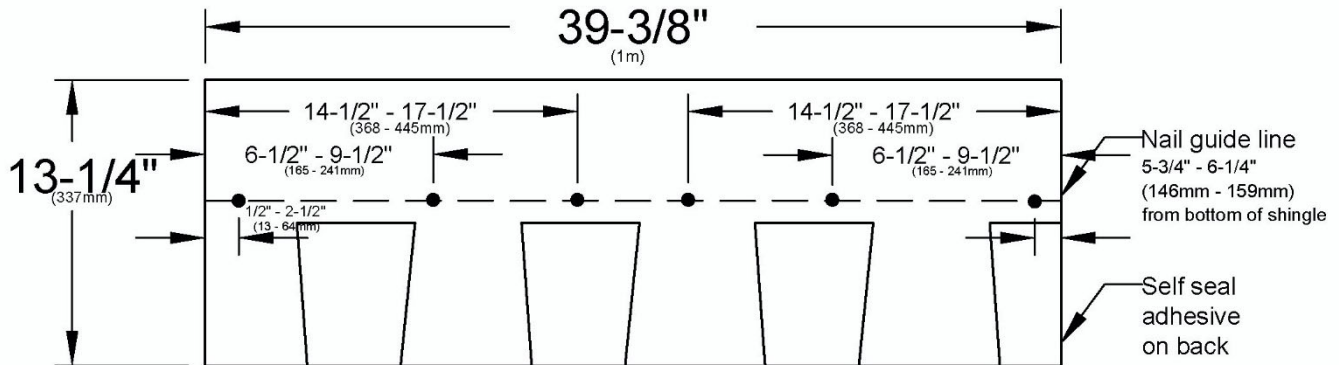

ENHANCED NAILING PATTERN - six nails per shingle*

* required by some local codes and required for enhanced wind coverage on certain products.
 See limited warranty for details.

These shingles **MUST** be nailed a nominal 6" (152mm) from bottom of of shingle, above the cut outs, as shown. Nails must **not** be exposed.

OVERALL DIMENSIONS AND NAILING PATTERN
FOR TIMBERLINE HDZ®, TIMBERLINE® CS, TIMBERLINE® AH, TIMBERLINE®
UHDZ®, AND FORTITUDE®

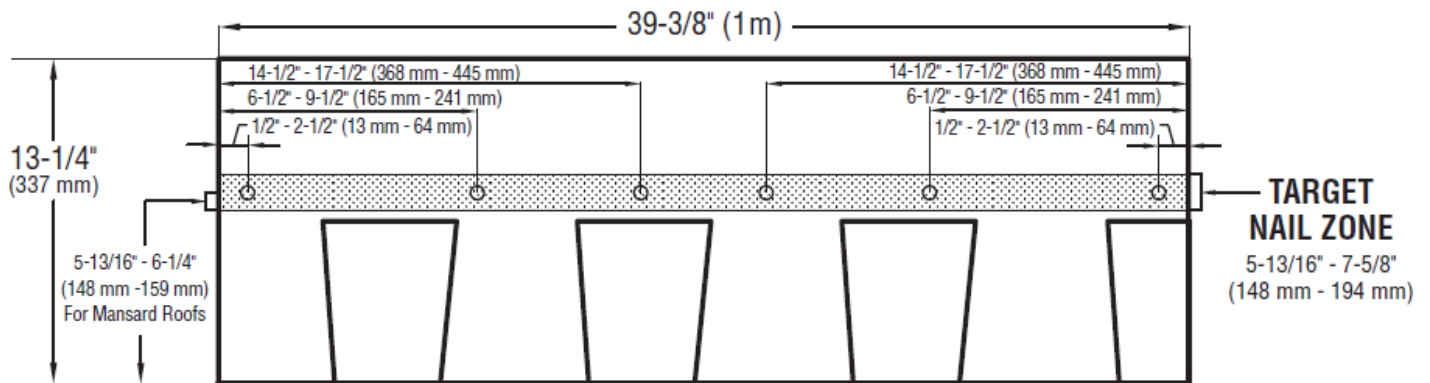

END OF THIS ACCEPTANCE

