

# emporía

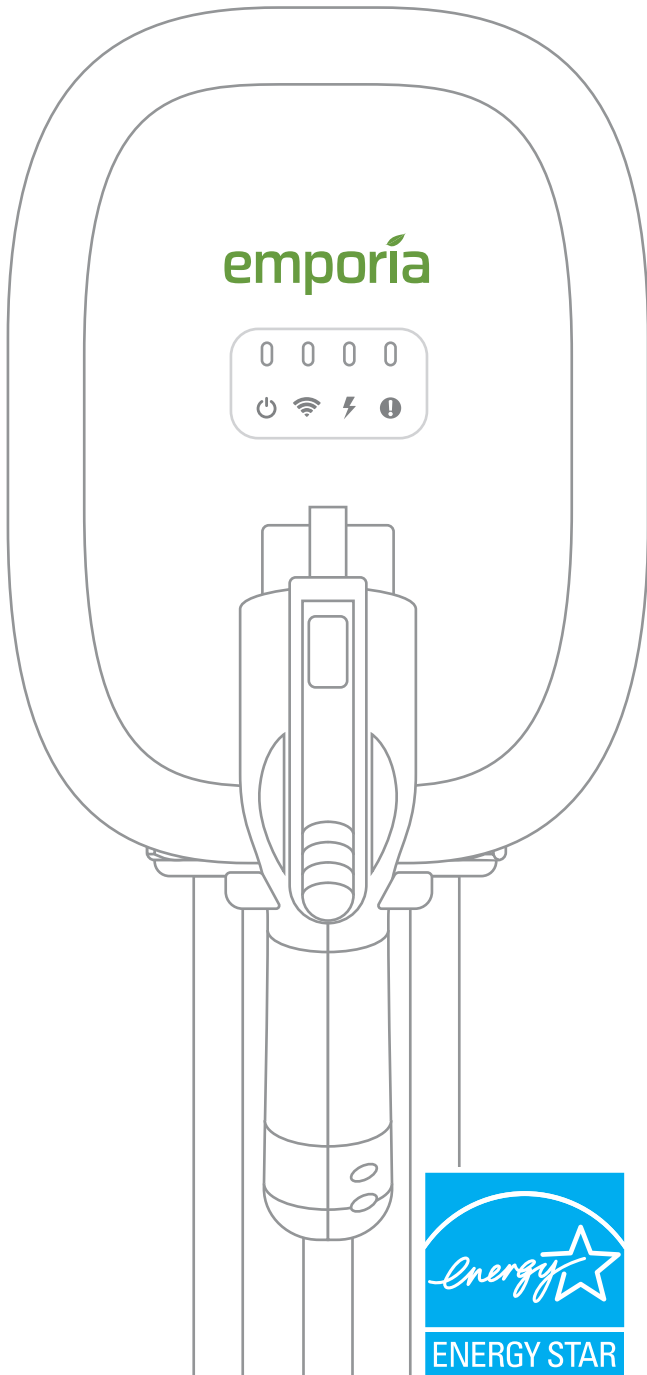

Smart Home  
**EV Charger**

**INSTALLATION  
AND USAGE GUIDE**



## **IMPORTANT SAFETY INSTRUCTIONS**

### **SAVE THESE INSTRUCTIONS**

#### **INSTRUCTIONS PERTAINING TO A RISK OF FIRE OR ELECTRIC SHOCK!**

Improper connection of the equipment- grounding conductor may result in a risk of electric shock, leading to death or serious injury. Emporia recommends that installation be performed by a licensed electrician or other qualified professional in accordance with the regional electrical code where it is being installed to ensure the Emporia EV Charger is properly grounded. Do not modify the provided plug – if it will not fit the outlet, have a proper outlet installed by a licensed electrician or other qualified professional.

#### **GROUNDING INSTRUCTIONS**

##### **For Plugged-In Installation:**

This product must be grounded. If it should malfunction or break down, grounding provides a path of least resistance for electric current to reduce the risk of electric shock. This product is equipped with a cord having an equipment grounding conductor and a grounding plug. The plug must be plugged into an appropriate outlet that is properly installed and grounded in accordance with all local codes and ordinances.

**WARNING** - Improper connection of the equipment-grounding conductor is able to result in a risk of electric shock. Check with a qualified electrician or serviceman if you are in doubt as to whether the product is properly grounded. Do not modify the plug provided with the product - if it will not fit the outlet, have a proper outlet installed by a qualified electrician.

##### **For Hardwired Installation:**

This product must be connected to a grounded, metal, permanent wiring system, or an equipment-grounding conductor must be run with the circuit conductors and connected to the equipment grounding terminal or lead on the product.

# Safety information

## IMPORTANT SAFETY INSTRUCTIONS

### SAVE THESE INSTRUCTIONS

#### INSTRUCTIONS PERTAINING TO A RISK OF FIRE OR ELECTRIC SHOCK

- Read all the instructions before using this product.
- This device should be supervised when used around children.
- Do not put fingers into the electric vehicle connector.
- The Emporia EV Charger is intended for use with electric vehicles only. Specifically, it is intended only for electric vehicles not requiring ventilation during charging.
- The Emporia EV Charger is intended to be installed in stationary, grid-tied power systems. Do not use the Emporia EV Charger with back-up generators.
- Do not use the Emporia EV Charger in any manner other than specified in this installation guide.
- Do not attempt to disassemble or repair any of the components of the Emporia EV Charger. There are no user serviceable parts inside.
- Do not use this product if the flexible power cord or EV cable is frayed, has broken insulation, or any other signs of damage.
- Do not use this product if the enclosure or the EV connector is broken, cracked, open, or shows any other indication of damage.
- Do not install the Emporia EV Charger in environments with explosive gas or vapors; nor where temperatures are outside its operating range of -22°F to 122°F (-30°C to 50°C)
- Use 90°C wire, 6 AWG copper for setting 48A rating intended for field wiring connection.

# Moving and storage Instructions

- Improper moving or storage of the Emporia EV Charger may result in damage to the product that could result in a risk of fire or electric shock during subsequent use.
- Handle charger and packaging with care and avoid dropping it. When moving or lifting the Emporia EV Charger, always grasp the unit by the charging station enclosure. Never carry or lift the Emporia EV Charger by either the power cable or charging cord.
- Store the Emporia EV Charger indoors and in its original packaging until it is ready to be installed. Storage temperature should be between -22°F to 122°F (-30°C to 50°C)

## Need help?

-  [emporiaenergy.com/support](https://emporiaenergy.com/support)
-  [support@emporiaenergy.com](mailto:support@emporiaenergy.com)
-  1-844-EMPORIA (367-6742)

# What's in the box

Your new Emporia EV Charger contains the following items. **If any of these items are missing or if you believe they've been damaged, call support immediately.**

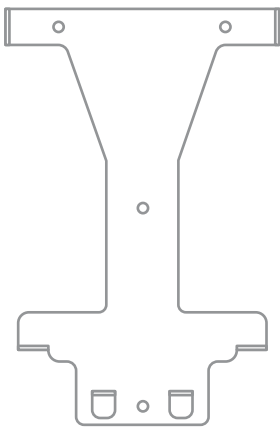
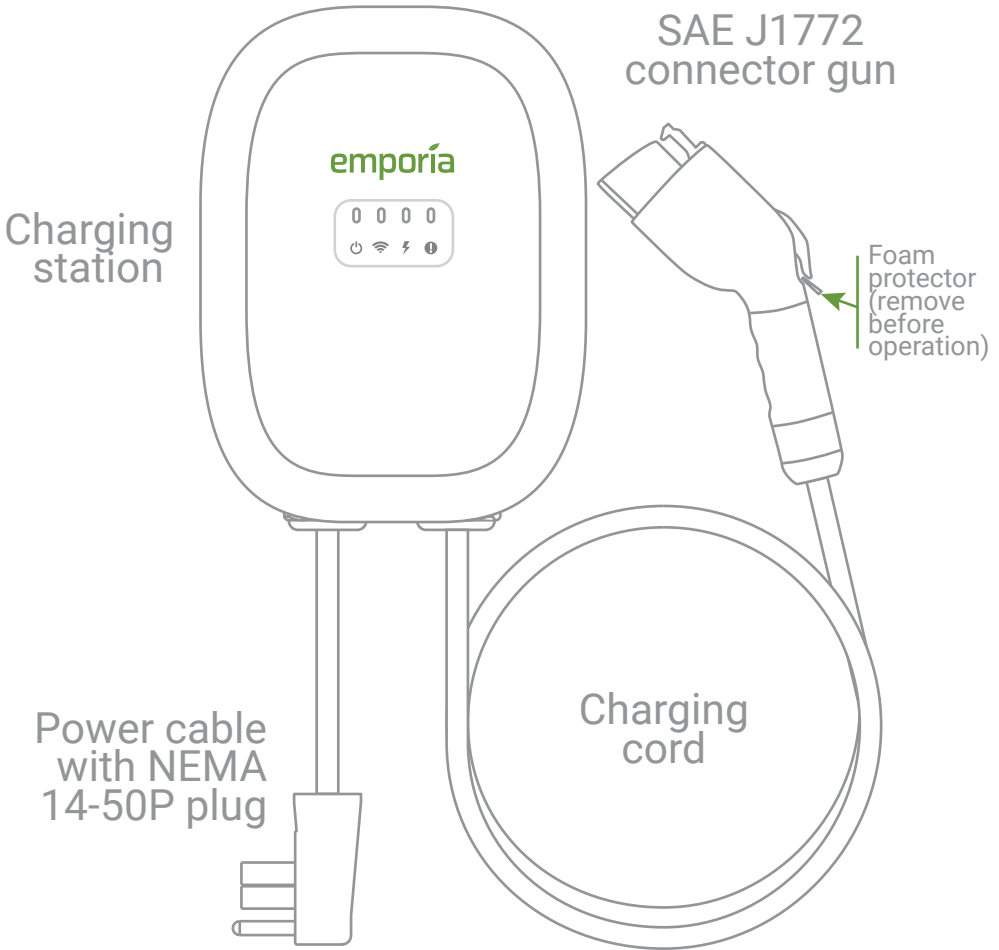

Mounting bracket

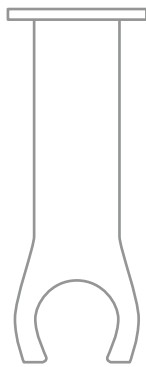

Gun cradle



Four M5X10 Phillips screws



Allen wrench

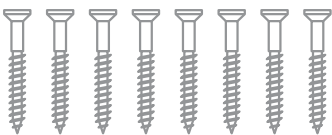

Eight  $\frac{7}{32}$  inch #12 Phillips screws

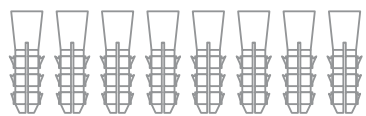

8 drywall anchors

# Before you get started

Here are the tools you will need to install the EV Charger.

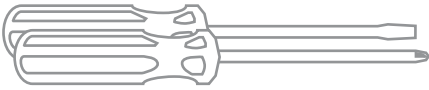

Phillips and flathead screwdrivers



Bubble level



Pencil



Hammer



iOS or Android phone or tablet

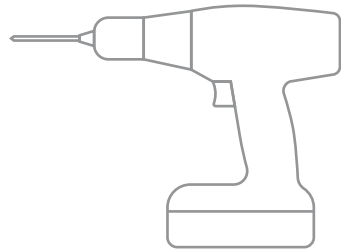

Drill with a 5/16" drill bit

## Need help?

-  [emporiaenergy.com/support](https://emporiaenergy.com/support)
-  [support@emporiaenergy.com](mailto:support@emporiaenergy.com)
-  1-844-EMPORIA (367-6742)

## Step 1: Get the App

Use your phone to check the signal strength of your Wi-Fi network where the EV Charger will be installed. Low/no signal may require a Wi-Fi extender for the Charger to work. Download the **Emporia Energy app** onto your phone or tablet from the Apple App Store, from Google Play, or from [emporiaenergy.com/app](http://emporiaenergy.com/app). **Create an account and begin the setup process.**



Download on the  
**App Store**



GET IT ON  
**Google Play**

[emporiaenergy.com/app](http://emporiaenergy.com/app)

## Step 2: How is the EV Charger powered?



### Hardwired installation See Step 8a

- EV Charger can supply a maximum charge of 48A to the EV
- Requires a dedicated dual pole breaker. We recommend 60A. **CAUTION: To reduce the risk of fire, connect only to a circuit provided with 60 amperes maximum branch circuit over current protection in accordance with the National Electrical Code, ANSI/NFPA 70 and the Canadian Electrical Code, Part I, C22.1.**

Dedicated Breaker	Charge Power @ 240V	
15A	2.9kW	12A
20A	3.8kW	16A
25A	4.8kW	20A
30A	5.8kW	24A
35A	6.7kW	28A
40A	7.7kW	32A
45A	8.6kW	36A
50A	9.6kW	40A
60A	11.5kW	48A



### Plugged-in installation See Step 8b

- EV Charger can supply a maximum charge of 40A to the EV
- Requires a dedicated, 50A dual pole breaker.
- Requires a NEMA 14-50R receptacle outlet

## Step 3: Find a place for the EV Charger

This device shall be mounted at a sufficient height from grade such that the height of the storage means for the coupling device is located between 24" (600 mm) and 48" (1.2 m) from grade; the distance from the vehicle allows slack for charging cable; temperatures are between -22°F to 122°F; the charger is within range of WiFi signal; and if plugged-in, the distance from the NEMA outlet allows slack for a short cable.

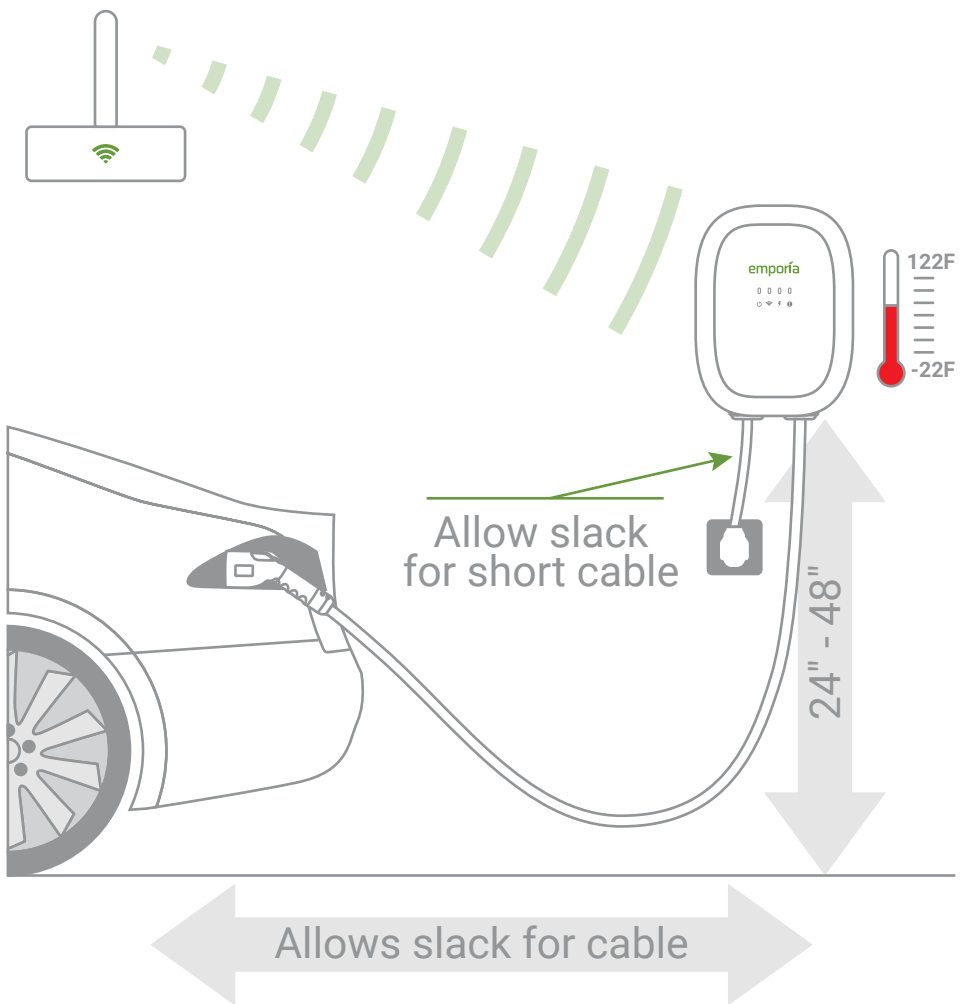

## Need help?

-  [emporiaenergy.com/support](https://emporiaenergy.com/support)
-  [support@emporiaenergy.com](mailto:support@emporiaenergy.com)
-  1-844-EMPORIA (367-6742)

## Step 4: Mark the mounting bracket location

On the plasterboard / drywall where the charger will be installed, use a bubble level to **draw a horizontal line** where the top of the EV Charger will sit on the wall ensuring it is mounted at a sufficient height from grade such that the height of the storage means for the coupling device is located between 24" (600 mm) and 48" (1.2 m) from grade and allows slack for the NEMA cable if it will be plugged in. Then, align the top of the mounting bracket to the line and **mark the 4 mounting holes**.

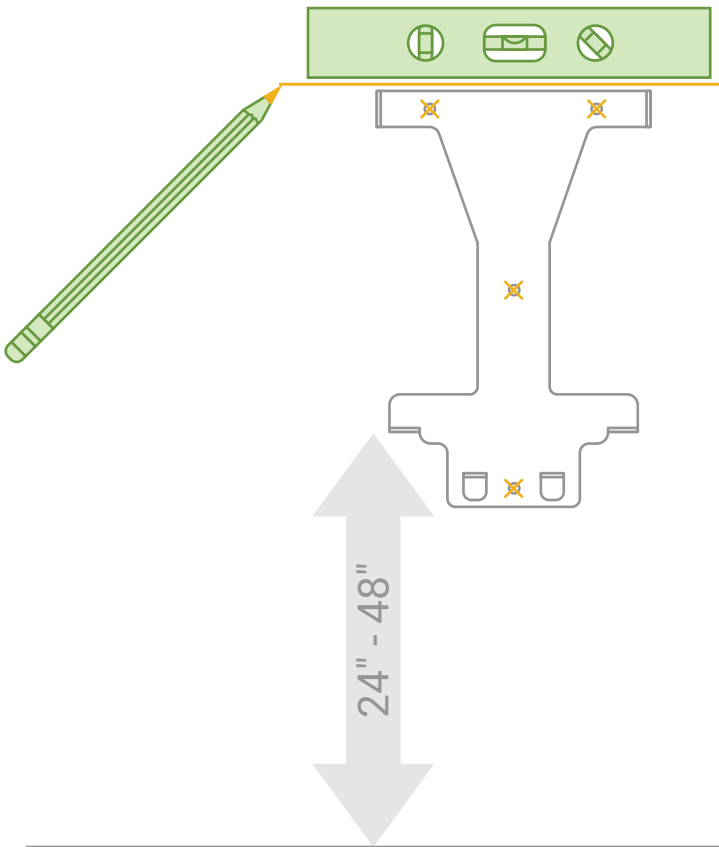

## Need help?

-  [emporiaenergy.com/support](https://emporiaenergy.com/support)
-  [support@emporiaenergy.com](mailto:support@emporiaenergy.com)
-  1-844-EMPORIA (367-6742)

## Step 5: Install the mounting bracket

For each mark, drill a 5/16" hole in the wall. Use a hammer to tap in the 4 drywall anchors. **If you would like to install the gun cradle under the EV Charger**, install the mounting bracket with 3 Phillips screws into the top 3 anchors, **omitting the bottom screw, and go to Step 6a.** **If you'd like to install the gun cradle off to the side of the EV Charger**, install the mounting bracket with the 4 Phillips screws into the anchors and proceed to Step 6b.

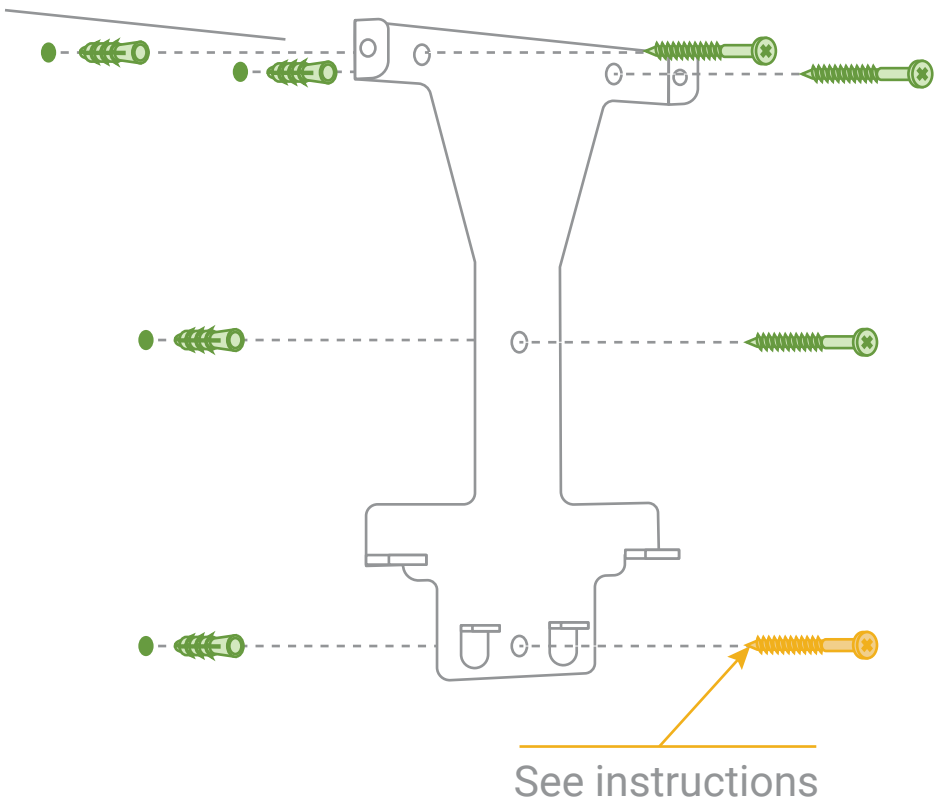

## Need help?

-  [emporiaenergy.com/support](https://emporiaenergy.com/support)
-  [support@emporiaenergy.com](mailto:support@emporiaenergy.com)
-  1-844-EMPORIA (367-6742)

## Step 6a: Install the gun cradle under the Charger

The gun cradle is designed to be installed directly under the EV Charger. **If you wish to install it off to the side of the EV Charger, skip to Step 6b.** Hang the gun cradle on the mounting bracket hooks. Mark the bottom mounting hole of the gun cradle. Drill a 5/16" hole in the wall at your mark. Use a hammer to tap in a drywall anchor. Install the gun cradle with 2 Phillips screws into the anchors.

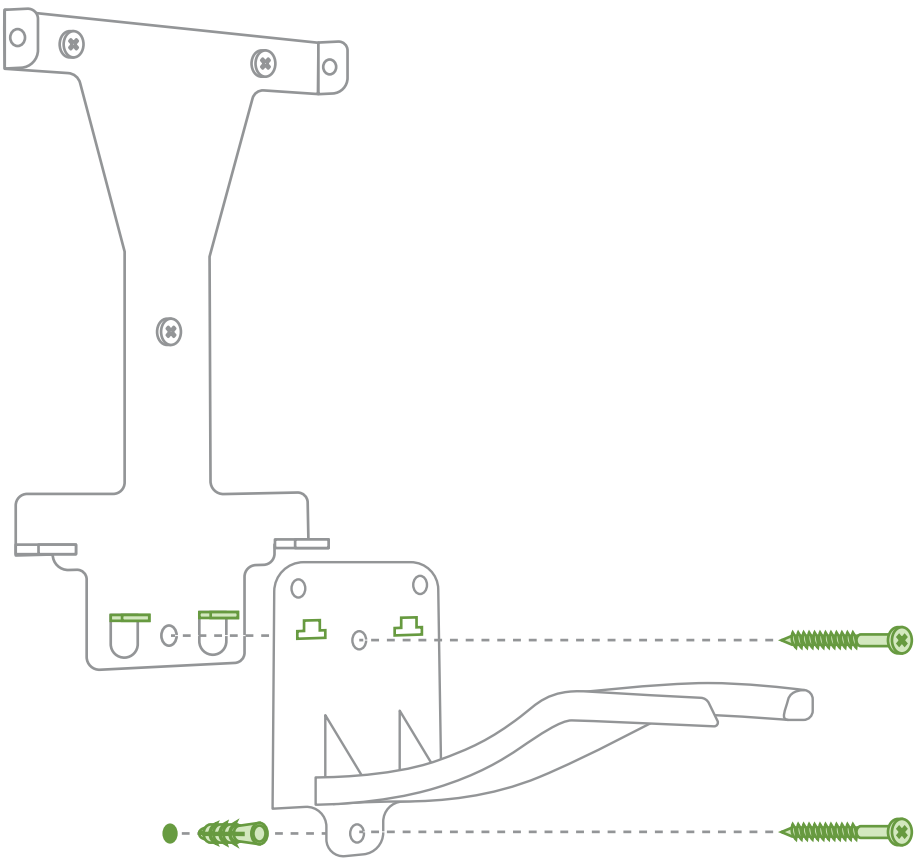

## Need help?

-  [emporiaenergy.com/support](https://emporiaenergy.com/support)
-  [support@emporiaenergy.com](mailto:support@emporiaenergy.com)
-  1-844-EMPORIA (367-6742)

## Step 6b: Install the gun cradle beside the Charger

Use a bubble level to **draw a horizontal line** at least 12" away from the mounting bracket at the height you'd like the cradle beside your EV Charger. Holding the gun cradle up to your line, mark the top two and bottom mounting holes of the gun cradle. Drill a 5/16" hole in the wall for each mark. Use a hammer to tap in 4 drywall anchors. Install the gun cradle with 4 Phillips screws into the anchors.

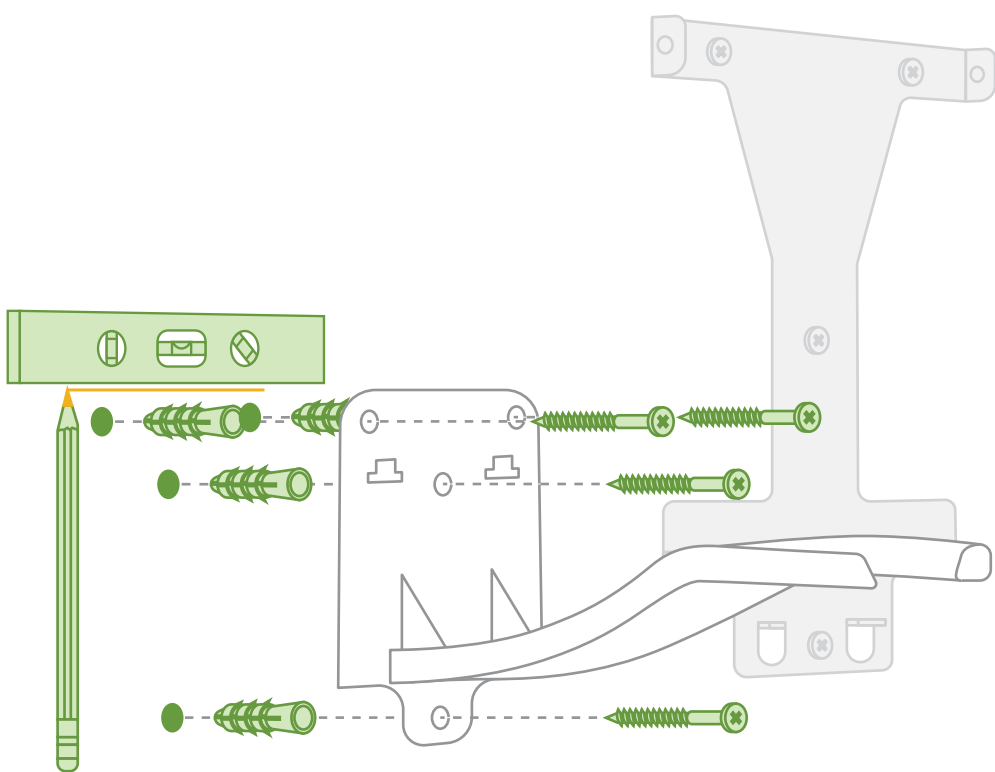

## Need help?

-  [emporiaenergy.com/support](https://emporiaenergy.com/support)
-  [support@emporiaenergy.com](mailto:support@emporiaenergy.com)
-  1-844-EMPORIA (367-6742)

## Step 7: Mount the EV Charger

Use a Phillips screwdriver and the 4 Phillips bolts to install the EV Charger on the mounting bracket.

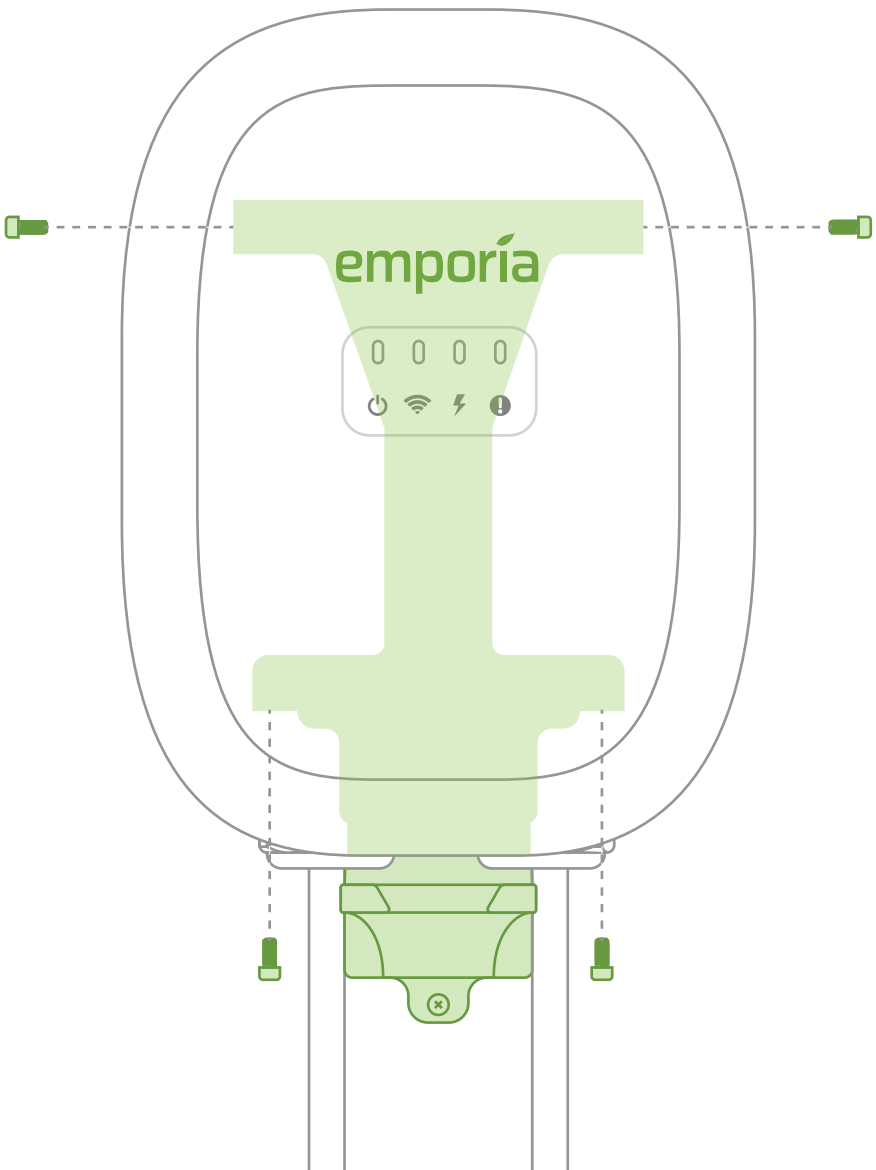

## Need help?

-  [emporiaenergy.com/support](https://emporiaenergy.com/support)
-  [support@emporiaenergy.com](mailto:support@emporiaenergy.com)
-  1-844-EMPORIA (367-6742)

# Step 8a-1: Hardwired instructions for electricians



A licensed electrician or other qualified professional can follow these instructions to hardwire the EV Charger to a breaker. **If you plan to power your EV Charger with a NEMA 14-50R receptacle outlet, skip to Step 8b.** First, turn off the dedicated dual-pole breaker that will power the EV Charger.

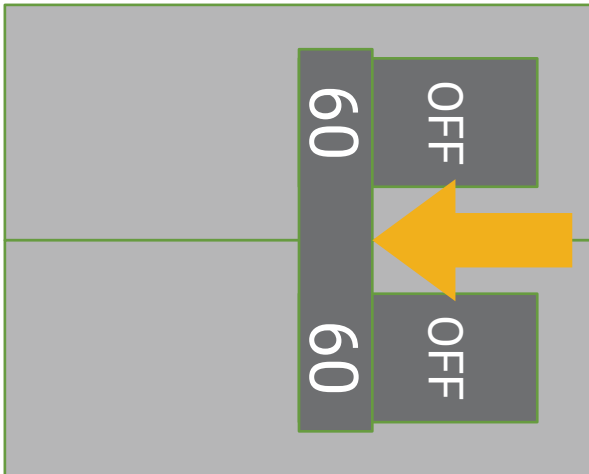

## Need help?

-  [emporiaenergy.com/support](https://emporiaenergy.com/support)
-  [support@emporiaenergy.com](mailto:support@emporiaenergy.com)
-  1-844-EMPORIA (367-6742)

## Step 8a-2: Hardwired instructions for electricians

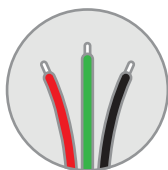

**From the back of the EV Charger**, use the Allen wrench to remove the 8 screws to detach the front cover. **Caution: there's a cable connecting the cover to the circuit board in the Charger. To remove the cable, gently grab the cable bundle and pull it away from the circuit board.**

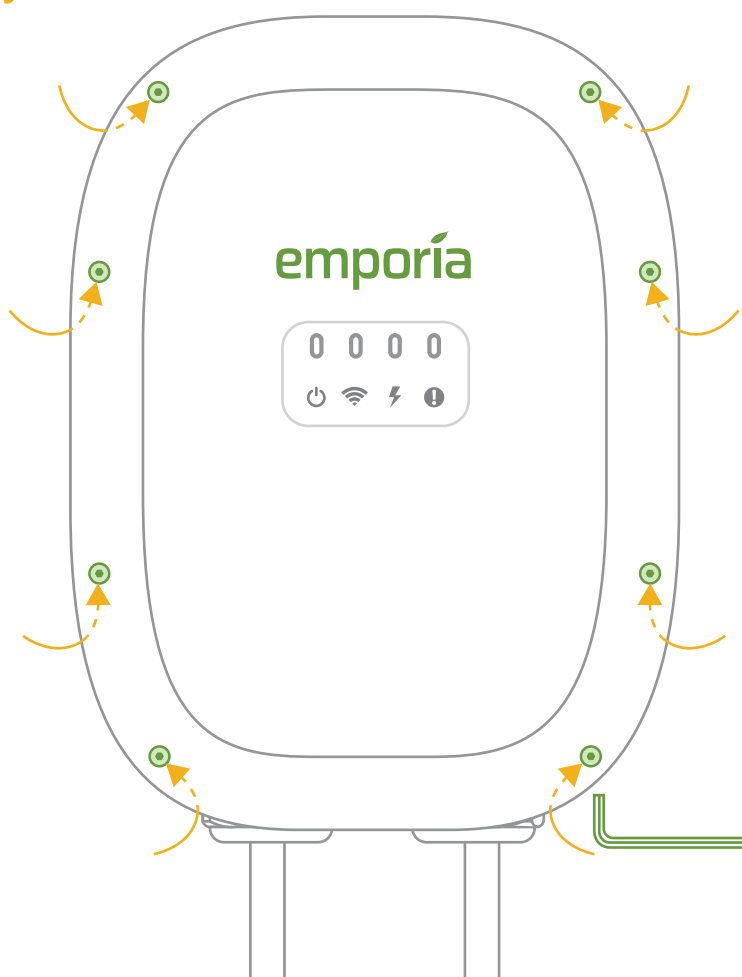

### Need help?

-  [emporiaenergy.com/support](https://emporiaenergy.com/support)
-  [support@emporiaenergy.com](mailto:support@emporiaenergy.com)
-  1-844-EMPORIA (367-6742)

## Step 8a-3: Hardwired instructions for electricians

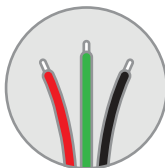

Unscrew the screws for terminals 1, 2, and 3 to remove the Black, Red, and Green NEMA cable wires

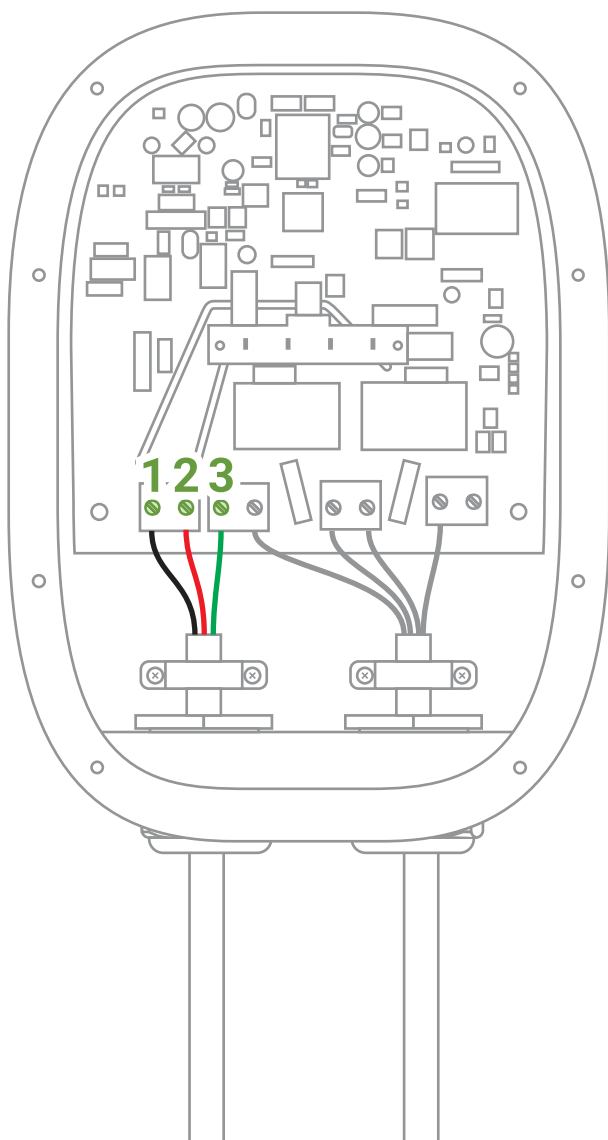

## Need help?

-  [emporiaenergy.com/support](https://emporiaenergy.com/support)
-  [support@emporiaenergy.com](mailto:support@emporiaenergy.com)
-  1-844-EMPORIA (367-6742)

## Step 8a-4: Hardwired instructions for electricians



Unscrew the screws to remove the clamp securing NEMA cable. Then, remove the NEMA cable from the assembly. Finally, unscrew the nut holding the cable gland in place and remove it from the assembly.

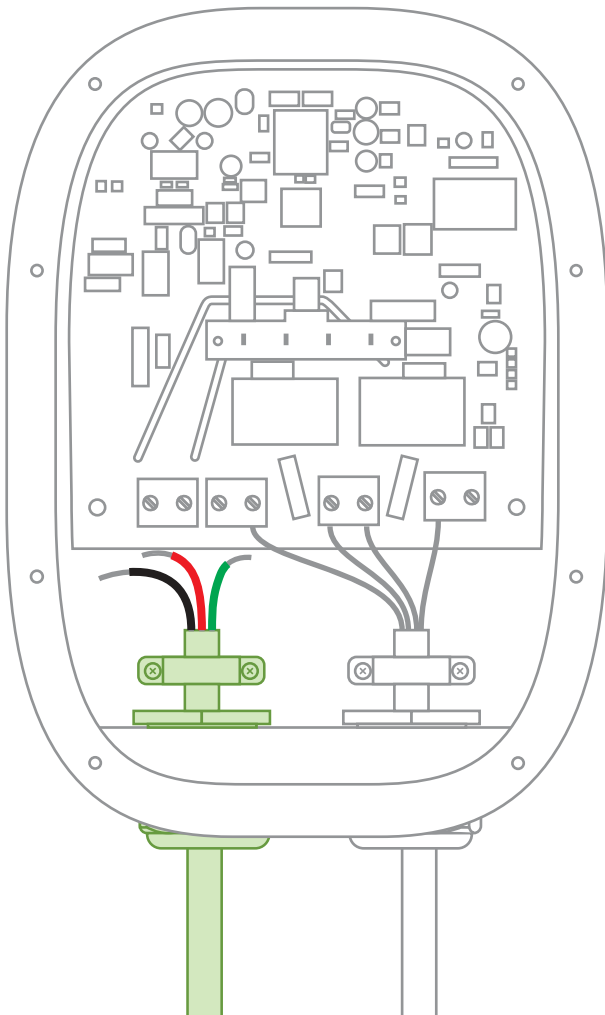

## Need help?

-  [emporiaenergy.com/support](https://emporiaenergy.com/support)
-  [support@emporiaenergy.com](mailto:support@emporiaenergy.com)
-  1-844-EMPORIA (367-6742)

# Step 8a-5: Hardwired instructions for electricians



Using 1-¼" conduit and proper fittings for the connections, use 90°C wire, 6 AWG copper for setting 48A rating from both phases of the breaker along with a ground/earth lead into the EV Charger assembly. Insert the phase 1 lead into terminal 1, the phase 2 lead into terminal 2, and the ground into terminal 3 and secure them with the screws, **applying a tightening torque of 1.2 Nm.**

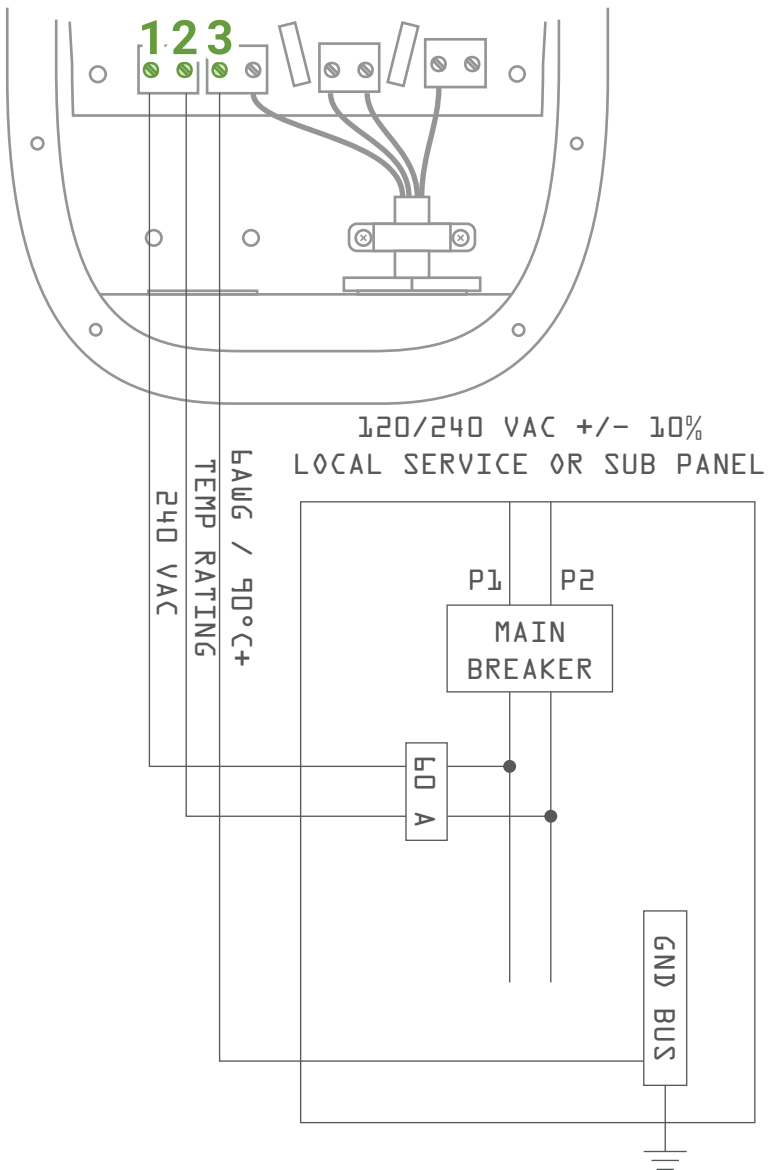

## Step 8a-6: Hardwired instructions for electricians



**Gently reattach the cable to the cover and the circuit board. Then, from the back of the EV Charger, use the Allen wrench to replace the 8 screws to reattach the front cover.**

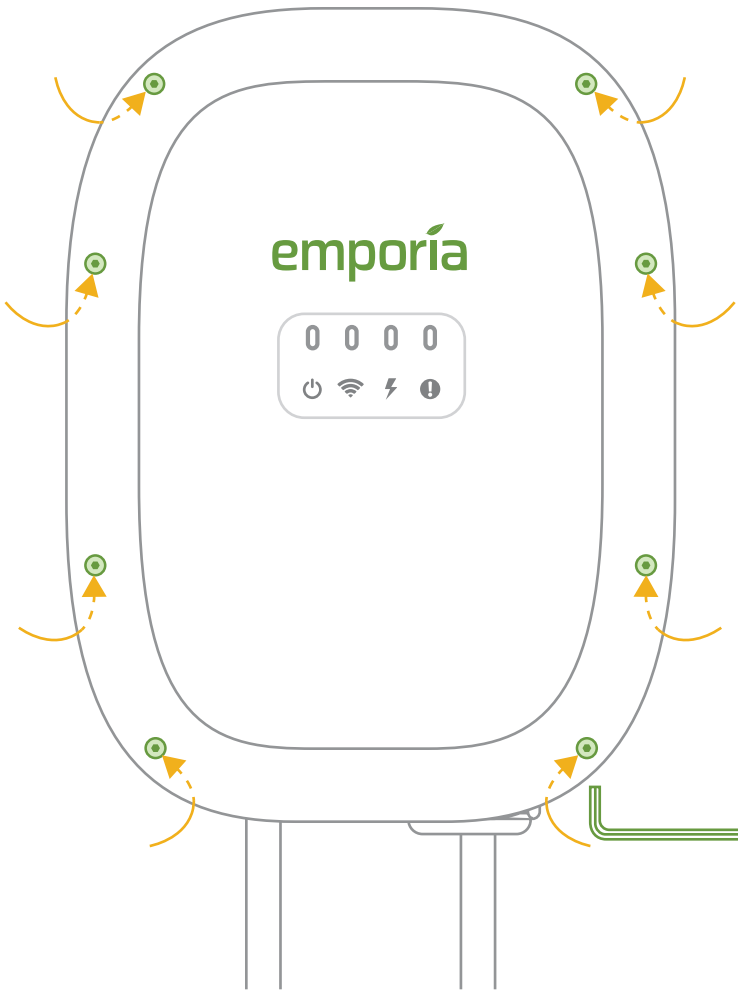

## Need help?

-  [emporiaenergy.com/support](https://emporiaenergy.com/support)
-  [support@emporiaenergy.com](mailto:support@emporiaenergy.com)
-  1-844-EMPORIA (367-6742)

## Step 8a-7: Hardwired instructions for electricians



Turn on the breaker and ensure that the power light on the front of the EV Charger is illuminated.

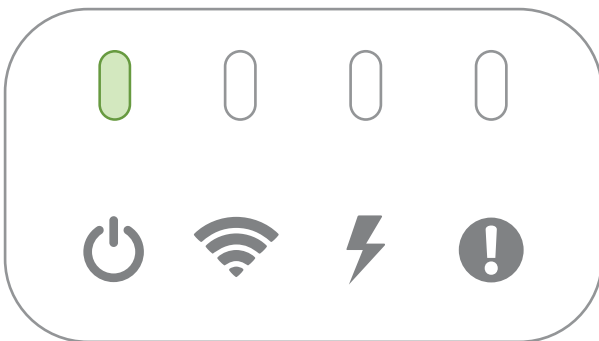
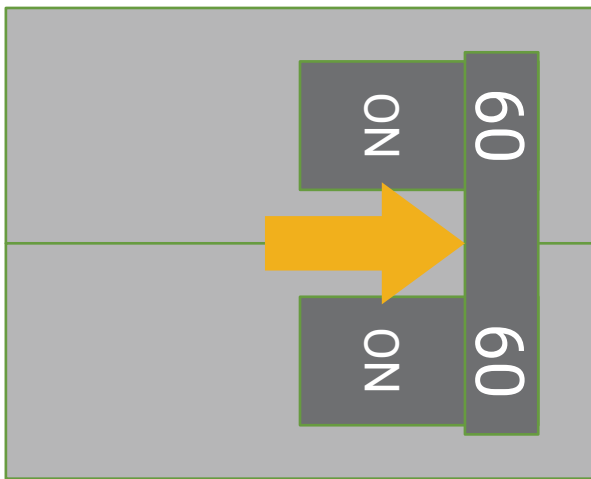

## Need help?

-  [emporiaenergy.com/support](https://emporiaenergy.com/support)
-  [support@emporiaenergy.com](mailto:support@emporiaenergy.com)
-  1-844-EMPORIA (367-6742)

# Step 8b-1: Plugged in instructions for electricians



If a NEMA 14-50R receptacle outlet is not already at the EV Charger location, a licensed electrician or other qualified professional can follow these instructions to install one. First, turn off the dedicated dual-pole breaker that will power the EV Charger.

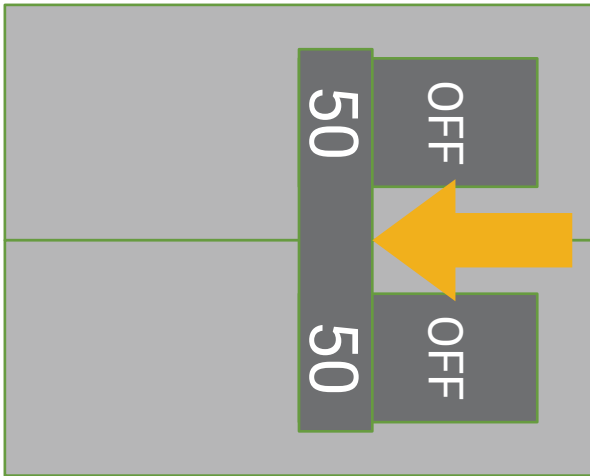

## Need help?

-  [emporiaenergy.com/support](https://emporiaenergy.com/support)
-  [support@emporiaenergy.com](mailto:support@emporiaenergy.com)
-  1-844-EMPORIA (367-6742)

# Step 8b-2: Plugged in instructions for electricians



Install a NEMA 14-50R receptacle outlet with the ground facing downward ensuring the distance between the NEMA outlet and the EV Charger allows slack for a short cable. Bring leads from both phases of the breaker along with a ground/earth lead to the outlet and connect them. **Neutral is not required.**

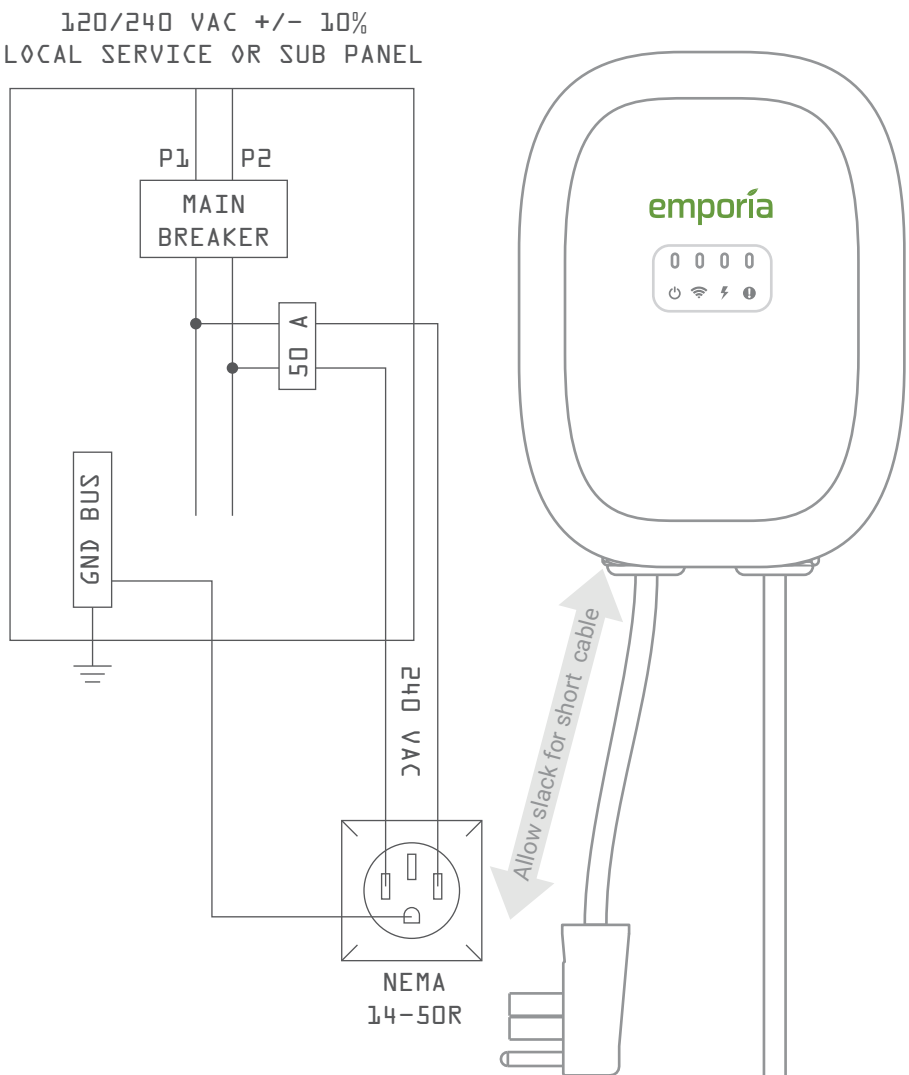

## Step 8b-3: Plugged in instructions for electricians



Plug in the NEMA 14-50P plug from the EV Charger into the receptacle outlet. Turn on the breaker and ensure that the power light on the front of the EV Charger is illuminated.

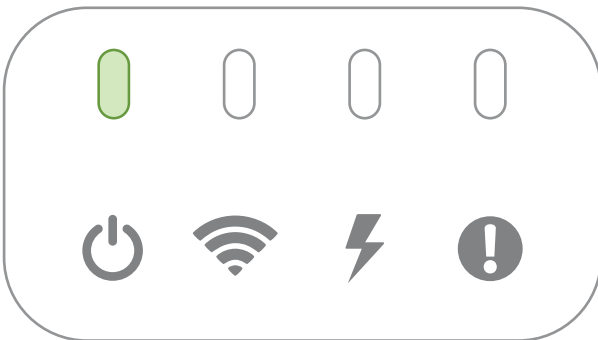
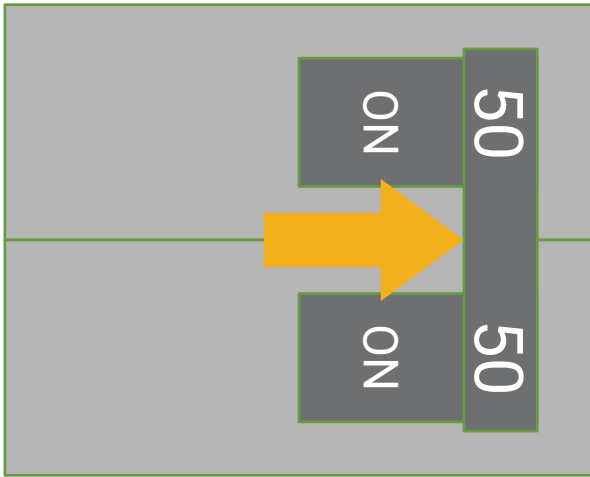

## Need help?

- [emporiaenergy.com/support](https://emporiaenergy.com/support)
- [support@emporiaenergy.com](mailto:support@emporiaenergy.com)
- 1-844-EMPORIA (367-6742)

## Step 9: Complete setup

**Your EV Charger is now ready to charge your vehicle.** It is set from the factory to charge at 40 Amps. To raise or lower the charge rate to match your breaker size and to take advantage of the numerous other features available from Emporia, return to the Emporia App, choose Add a Device under Manage Devices and follow the instructions to set up your EV Charger. Your phone will connect via Bluetooth to the system and then you'll connect to a nearby Wi-Fi router. Make sure you have your Wi-Fi name and password.



## Need help?

-  [emporiaenergy.com/support](https://emporiaenergy.com/support)
-  [support@emporiaenergy.com](mailto:support@emporiaenergy.com)
-  1-844-EMPORIA (367-6742)

# Charging your vehicle

**Your charger is set from the factory to charge at 40 Amps. You can raise or lower this rate only through the Emporia app.** To charge your vehicle, open the port door and plug the EV Charger gun into the port. You will see the charge light on the EV Charger switch to solid blue when it is connected to the vehicle. It will begin breathing blue as the vehicle charges. Additionally, most EVs have indicator lights on the dashboard to let you know that you're charging. Do not attempt to drive your vehicle while the charge cable is connected to your vehicle.

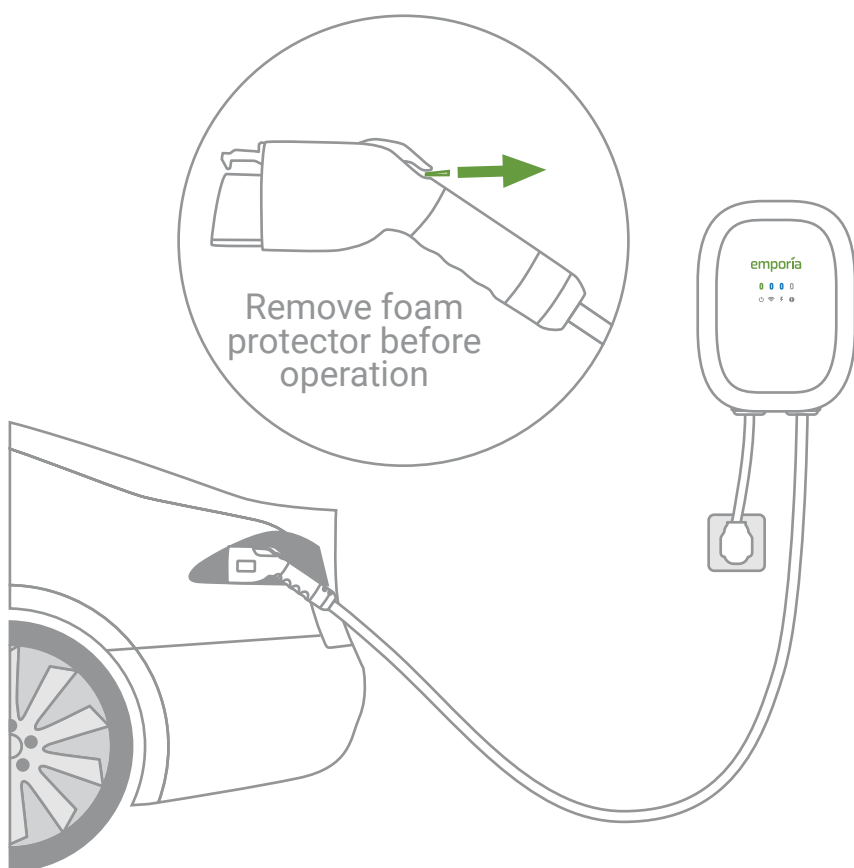

## Need help?

- 🗨 [emporiaenergy.com/support](https://emporiaenergy.com/support)
- ✉ [support@emporiaenergy.com](mailto:support@emporiaenergy.com)
- ☎ 1-844-EMPORIA (367-6742)

## Charging your Tesla EV

The Emporia EV Charger requires a Tesla J1772 adapter to charge a Tesla. If you don't already own one, these can be purchased directly from [shop.tesla.com](https://shop.tesla.com).

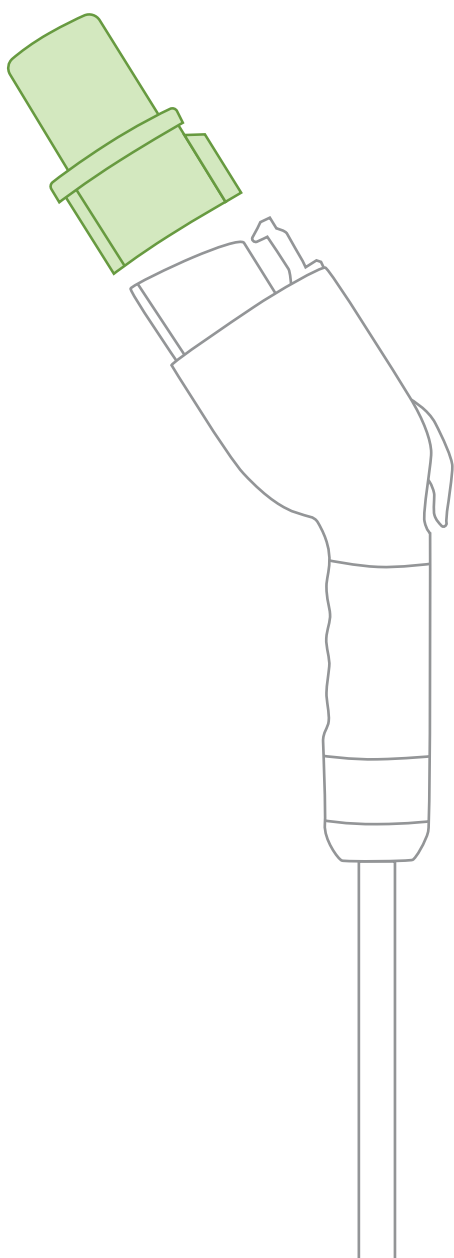

## Need help?

-  [emporiaenergy.com/support](https://emporiaenergy.com/support)
-  [support@emporiaenergy.com](mailto:support@emporiaenergy.com)
-  1-844-EMPORIA (367-6742)

# EV Charger LED lights

🔌 Power	
Off	Charger does not have power
Solid green	Charger has power
⚡ Charge	
Off	No vehicle connected
Solid Blue	Vehicle connected
Flashing Blue	Offering charge
Breathing Blue	Vehicle charging
📶 WiFi	
Solid Red	Not connected to router
Flashing Red	Lost connection to router
Flashing Green	Connecting to router
Solid Green	Connected to router, but not the Internet
Solid Blue	Connected to the router and the Internet
! Fault	
Flashing orange 1 slow/1 fast	Abnormal control pilot circuit Unplug and plug-in Emporia EV Charger. If issue persists, contact Support.
Flashing orange 1 slow/2 fast	Charger has exceeded operating temperature lower bound. Ensure the charger is installed where temperatures do not drop below -22F (-30C)
Flashing orange 1 slow/3 fast	Input voltage is too low If plugged in, check that the NEMA 14-50P is plugged in securely. Check the supply breaker in your breaker panel for damage and replace if necessary. If issue persists, contact Support.
Flashing orange 1 slow/4 fast	Input voltage is too high If plugged in, check that the NEMA 14-50P is plugged in securely. Check the supply breaker in your breaker panel for damage and replace if necessary. If issue persists, contact Support.
Flashing orange 1 slow/5 fast	Charger has exceeded nominal temperature Ensure the charger is installed where ambient temperatures will not exceed 122°F (50°C). If issue persists, contact Support.

## Need help?

- 🗨️ [emporiaenergy.com/support](https://emporiaenergy.com/support)
- ✉️ [support@emporiaenergy.com](mailto:support@emporiaenergy.com)
- ☎️ 1-844-EMPORIA (367-6742)

# EV Charger LED lights (cont.)

! Fault (cont.)	
Flashing orange 1 slow/6 fast	Output surge current Unplug from car. Disconnect charger from power. Confirm there is no visible damage or foreign material in the EV gun. Return power to charger. If issue persists, contact Support.
Flashing orange 1 slow/7 fast	Current leakage Unplug from car. Disconnect charger from power. Confirm there is no visible damage or foreign material in the EV gun. Return power to charger. If issue persists, contact Support.
Flashing orange 1 slow/8 fast	Output short circuit Unplug from car. Disconnect charger from power. Confirm there is no visible damage or foreign material in the EV gun. Return power to charger. If issue persists, contact Support.
Flashing orange 1 slow/9 fast	Output over current Unplug from car. Disconnect charger from power. Confirm there is no visible damage or foreign material in the EV gun. Return power to charger. If issue persists, contact Support.
Flashing orange 2 slow/1 fast	Vehicle is not responding. Ensure that the latch on the EV charging cable handle is locked into place. If the handle is not latched securely, the vehicle will not charge. If the latch is pressed down during charging, charging automatically stops. Ensure that the vehicle is not set up to begin charging at a specific time of day.
Flashing orange 2 slow/2 fast	Vehicle interface issue. Ensure that the latch on the EV charging cable handle is locked into place. If the handle is not latched securely, the vehicle will not charge. If the latch is pressed down during charging, charging automatically stops. Ensure that the vehicle is not set up to begin charging at a specific time of day.
Flashing orange 2 slow/3 fast	Relay fused in position Disconnect from power immediately. Contact Support.
Flashing orange 2 slow/5 fast	Charger is not grounded Ensure that the EV Charger is properly wired and grounded. Check the line and neutral connections, as they may be reversed in the adapter or outlet. Unplug and reboot EV charger. If issue persists, contact Support.
Flashing orange 3 slow/1 fast	The car is requesting ventilation during charging, which is not supported by the Emporia EV Charger. Contact Support.
Flashing orange 3 slow/2 fast	The car is requesting charge but the charger is not ready. Unplug the gun from the port and plug it back in again. If issue persists, contact Support.

## Need help?

-  [emporiaenergy.com/support](https://emporiaenergy.com/support)
-  [support@emporiaenergy.com](mailto:support@emporiaenergy.com)
-  1-844-EMPORIA (367-6742)

# Troubleshooting Tips

## The Emporia app is not finding my EV Charger after I've installed it.

- Ensure the Charger has power:
  - Check for a green power light.
  - Check the EV Charger is wired properly.
  - Check that the breaker powering the EV Charger is turned on.
- Ensure your phone can connect to the EV Charger.
  - Check your phone's Bluetooth is on.
  - If you're using an Android, turn on Location Services for your phone to properly scan for Bluetooth devices.
- Try power cycling the breaker to which the EV Charger is connected.
- Try restarting the Emporia App.
- Try rebooting your phone.

## My vehicle is not responding or charging.

- Ensure that the latch on the EV charging cable handle is locked into place. If the handle is not latched securely, the vehicle will not charge. If the latch is pressed down during charging, charging automatically stops.
- Ensure that the vehicle is not set up to begin charging at a specific time of day.

## Need help?

-  [emporiaenergy.com/support](https://emporiaenergy.com/support)
-  [support@emporiaenergy.com](mailto:support@emporiaenergy.com)
-  1-844-EMPORIA (367-6742)

# Technical Specifications

<b>Input Voltage</b>	208/240VAC 50/60Hz
<b>Power Charge</b>	11.5kW (240V/48A) / 9.6kW (240V/40A) / 10kW (208V/48A) / 8.3kW (208V/40A)
<b>Required Breaker</b>	Dedicated 50A+ dual pole for 40A Dedicated 60A+ dual pole for 48A
<b>Connector</b>	24' cable SAE J1772 connector
<b>Power Wiring</b>	NEMA Type 14-50P (up to 40A) with 24" cable compliant with 2017 NEC Section 625.17(A)(3) / Hardwired (up to 48A)
<b>Enclosure</b>	Watertight NEMA Type 4 indoor/outdoor
<b>Temp Range</b>	-22°F to 122°F (-30°C to 50°C)



FCC ID: 2AS6P-EMEVSE1  
Model: EMEVSE1



IC: 28084-EMEVSE1

The Emporia Smart Home EV Charger contains FCC ID: 2AS6P-EMEVSE1. This device complies with part 15 of the FCC Rules. Operation is subject to the following two conditions: (1) this device may not cause harmful interference, and (2) this device must accept any interference received, including interference that may cause undesired operation. This equipment complies with FCC RF radiation exposure limits set forth for an uncontrolled environment. This equipment should be installed and operated with a minimum distance of 20 centimeters between the radiator and your body.

**Caution:** Any changes or modifications not expressly approved by Emporia void the user's authority to operate the equipment.

# Automate your Charging



## Peak Demand Management

With the Emporia Vue, set a Peak Demand Goal for your system and let Emporia take care of the rest – automatically adjusting your Emporia EV Charger charge rates to meet this goal.

## Charge with Solar

For homes that generate solar or other renewable energy, the Vue can adjust your EV Charger to automatically charge your vehicle to consume the excess generation.

Learn more: [emporiaenergy.com](https://emporiaenergy.com)