

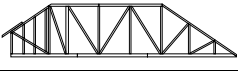

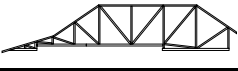















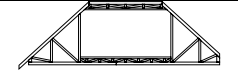
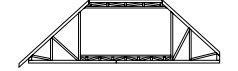

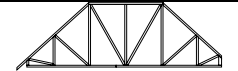
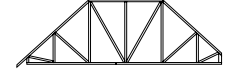
Builder: Amira Builders
Subdivision: SHORT RES.
Jurisdiction:
State: FL
Lot: N/A
Model: CUSTOM
Shipment: Roof
Elevation: GABLE
Option:

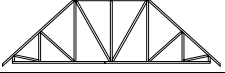
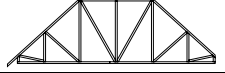
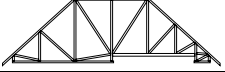
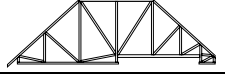
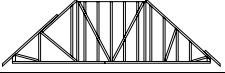
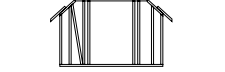
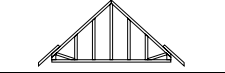
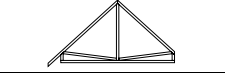
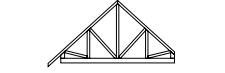
OnLine Job No:
Pick Ticket:
Sales No:
Acct No:
Ship Date: 12/25/2022
Designer: Conard, Ryan
AppWrt JobNo: 3039076

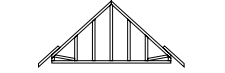
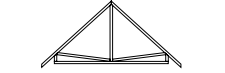
	A01 1 (2Ply)	Jnt-25 123.5" Gravity: 840 lbs (plf) Uplift: -318 lbs (plf)	Jnt-21 3.5" Gravity: 19442 lbs Uplift: -6453 lbs	Jnt-13 5.5" Gravity: 9737 lbs Uplift: -3598 lbs
	A02 6	Jnt-2 3.0" Gravity: 135 lbs Uplift: -347 lbs	Jnt-24 5.5" Gravity: 2240 lbs Uplift: -858 lbs	Jnt-13 5.0" Gravity: 1835 lbs Uplift: -546 lbs
	A03 6	Jnt-15 5.0" Gravity: 588 lbs Uplift: -324 lbs	Jnt-11 3.5" Gravity: 1715 lbs Uplift: -890 lbs	Jnt-8 5.0" Gravity: 620 lbs Uplift: -345 lbs
	A04 1	Jnt-25 5.0" Gravity: 623 lbs Uplift: -263 lbs	Jnt-21 3.5" Gravity: 1854 lbs Uplift: -879 lbs	Jnt-15 5.0" Gravity: 710 lbs Uplift: -286 lbs
	A05 3	Jnt-16 1.5" Gravity: 1541 lbs Uplift: -566 lbs	Jnt-8 1.5" Gravity: 1524 lbs Uplift: -597 lbs	
	A06 1	Jnt-40 1.5" Gravity: 1376 lbs Uplift: -570 lbs	Jnt-22 1.5" Gravity: 1376 lbs Uplift: -601 lbs	
	A07 1 (2Ply)	Jnt-14 1.5" Gravity: 2922 lbs Uplift: -2980 lbs	Jnt-7 1.5" Gravity: 3027 lbs Uplift: -3113 lbs	
	A08 4	Jnt-8 5.0" Gravity: 731 lbs Uplift: -324 lbs	Jnt-5 3.5" Gravity: 731 lbs Uplift: -434 lbs	
	B01 1	Jnt-2 95.5" Gravity: 143 lbs (plf) Uplift: -107 lbs (plf)	Jnt-45 3.5" Gravity: 1607 lbs Uplift: 0 lbs	Jnt-27 3.5" Gravity: 1571 lbs Uplift: 0 lbs
	(cont) B01 1	Jnt-22 95.5" Gravity: 149 lbs (plf) Uplift: -116 lbs (plf)		
	B02 1	Jnt-38 5.5" Gravity: 1984 lbs Uplift: -278 lbs	Jnt-16 5.5" Gravity: 1984 lbs Uplift: -278 lbs	
	B02A 3	Jnt-37 5.5" Gravity: 1986 lbs Uplift: -279 lbs	Jnt-15 5.5" Gravity: 1895 lbs Uplift: -202 lbs	
	B02B 5	Jnt-36 5.5" Gravity: 1957 lbs Uplift: -277 lbs	Jnt-15 3.5" Gravity: 1892 lbs Uplift: -187 lbs	
	B02C 6	Jnt-36 5.5" Gravity: 1926 lbs Uplift: -356 lbs	Jnt-16 4.0" Gravity: 769 lbs Uplift: -554 lbs	Jnt-15 1.5" Gravity: 1901 lbs Uplift: -544 lbs
	B02D 1	Jnt-38 5.5" Gravity: 2036 lbs Uplift: -651 lbs	Jnt-27 3.5" Gravity: 2707 lbs Uplift: -573 lbs	Jnt-18 116.0" Gravity: 192 lbs (plf) Uplift: -279 lbs (plf)
	(cont) B02D 1	Jnt-15 1.5" Gravity: 1871 lbs Uplift: -637 lbs		
	B04 7	Jnt-16 5.5" Gravity: 1374 lbs Uplift: -547 lbs	Jnt-9 3.5" Gravity: 1289 lbs Uplift: -470 lbs	
	B04A 1	Jnt-17 190.0" Gravity: 138 lbs (plf) Uplift: -64 lbs (plf)	Jnt-12 3.5" Gravity: 98 lbs Uplift: 0 lbs	Jnt-9 3.5" Gravity: 614 lbs Uplift: -209 lbs

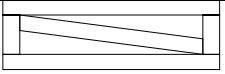

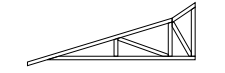
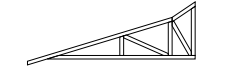
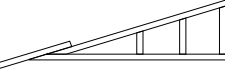







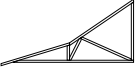
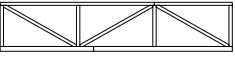

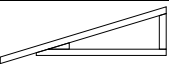
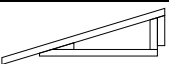

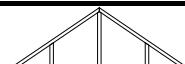

Builder: Amira Builders
Subdivision: SHORT RES.
Jurisdiction:
State: FL
Lot: N/A
Model: CUSTOM
Shipment: Roof
Elevation: GABLE
Option:

OnLine Job No:
Pick Ticket:
Sales No:
Acct No:
Ship Date: 12/25/2022
Designer: Conard, Ryan
AppWrt JobNo: 3039076

	B05 1	Jnt-17 5.5"		Jnt-10 5.5"			
		Gravity: 1395 lbs Uplift: -554 lbs	Gravity: 1395 lbs Uplift: -554 lbs				
	B05A 2	Jnt-16 5.5"		Jnt-9 5.5"			
		Gravity: 1398 lbs Uplift: -554 lbs	Gravity: 1311 lbs Uplift: -482 lbs				
	B06 4	Jnt-22 5.5"		Jnt-11 5.5"			
		Gravity: 1367 lbs Uplift: -553 lbs	Gravity: 1387 lbs Uplift: -549 lbs				
	B06A 2	Jnt-21 5.5"		Jnt-10 5.5"			
		Gravity: 1369 lbs Uplift: -553 lbs	Gravity: 1303 lbs Uplift: -477 lbs				
	B07 1	Jnt-34 5.5"		Jnt-30 3.5"		Jnt-28 203.5"	
		Gravity: 612 lbs Uplift: -241 lbs	Gravity: 209 lbs Uplift: -131 lbs	Gravity: 123 lbs (plf) Uplift: -84 lbs (plf)			
	B08 1	Jnt-22 180.0"					
		Gravity: 357 lbs (plf) Uplift: -311 lbs (plf)					
	D01 1	Jnt-18 162.0"					
		Gravity: 121 lbs (plf) Uplift: -90 lbs (plf)					
	D02 3	Jnt-7 5.5"		Jnt-5 5.5"			
		Gravity: 633 lbs Uplift: -252 lbs	Gravity: 522 lbs Uplift: -203 lbs				
	D03 2 (2Ply)	Jnt-11 5.5"		Jnt-7 5.5"			
		Gravity: 3937 lbs Uplift: -2902 lbs	Gravity: 5444 lbs Uplift: -3104 lbs				
	D04 1	Jnt-14 91.5"		Jnt-12 3.5"		Jnt-11 5.5"	
		Gravity: 102 lbs (plf) Uplift: -98 lbs (plf)	Gravity: 513 lbs Uplift: -470 lbs	Gravity: 267 lbs Uplift: -66 lbs			
	D05 1	Jnt-18 162.0"					
		Gravity: 121 lbs (plf) Uplift: -88 lbs (plf)					
	D06 1	Jnt-8 5.5"		Jnt-6 5.5"			
		Gravity: 627 lbs Uplift: -252 lbs	Gravity: 627 lbs Uplift: -252 lbs				
	EJ07 17	Jnt-6 5.5"		Jnt-3 1.5"		Jnt-4 1.5"	
		Gravity: 307 lbs Uplift: 0 lbs	Gravity: 178 lbs Uplift: -243 lbs	Gravity: 95 lbs Uplift: -69 lbs			
	F01 4	Jnt-4 2.5"		Jnt-3 1.5"			
		Gravity: 207 lbs Uplift: -82 lbs	Gravity: 207 lbs Uplift: -82 lbs				
	F02 1	Jnt-4 2.5"		Jnt-3 1.5"			
		Gravity: 510 lbs Uplift: -103 lbs	Gravity: 500 lbs Uplift: -90 lbs				
	G01 9	Jnt-2 3.0"		Jnt-6 1.5"			
		Gravity: 527 lbs Uplift: -466 lbs	Gravity: 424 lbs Uplift: -305 lbs				
	G02 1	Jnt-2 3.0"		Jnt-7 67.0"			
		Gravity: 300 lbs Uplift: -271 lbs	Gravity: 116 lbs (plf) Uplift: -88 lbs (plf)				
	G03 1	Jnt-2 110.0"					
		Gravity: 118 lbs (plf) Uplift: -78 lbs (plf)					
	G04 2	Jnt-2 180.8"					
		Gravity: 118 lbs (plf) Uplift: -86 lbs (plf)					



Builder: Amira Builders
Subdivision: SHORT RES.
Jurisdiction:
State: FL
Lot: N/A
Model: CUSTOM
Shipment: Roof
Elevation: GABLE
Option:

OnLine Job No:
Pick Ticket:
Sales No:
Acct No:
Ship Date: 12/25/2022
Designer: Conard, Ryan
AppWrt JobNo: 3039076

	G05 3	Jnt-2 5.5" Gravity: 691 lbs Uplift: -365 lbs	Jnt-6 1.5" Gravity: 614 lbs Uplift: -265 lbs
	K01 1	Jnt-9 5.5" Gravity: 2587 lbs Uplift: -1986 lbs	Jnt-5 5.5" Gravity: 2636 lbs Uplift: -2021 lbs
	K02 1	Jnt-6 3.5" Gravity: 1233 lbs Uplift: -835 lbs	Jnt-4 3.5" Gravity: 1233 lbs Uplift: -835 lbs
	M01 12	Jnt-2 3.0" Gravity: 349 lbs Uplift: -325 lbs	Jnt-4 5.0" Gravity: 162 lbs Uplift: -158 lbs
	M02 4	Jnt-2 3.0" Gravity: 334 lbs Uplift: -316 lbs	Jnt-11 3.5" Gravity: 120 lbs Uplift: -117 lbs
	M03 1	Jnt-7 5.5" Gravity: 491 lbs Uplift: -113 lbs	Jnt-5 3.5" Gravity: 446 lbs Uplift: -354 lbs
	M04 1	Jnt-8 53.5" Gravity: 97 lbs (plf) Uplift: -71 lbs (plf)	
	M05 2	Jnt-5 3.5" Gravity: 288 lbs Uplift: -181 lbs	Jnt-4 3.5" Gravity: 146 lbs Uplift: -123 lbs
	PB01 1	Jnt-1 173.2" Gravity: 91 lbs (plf) Uplift: -48 lbs (plf)	
	PB02 3	Jnt-2 173.2" Gravity: 139 lbs (plf) Uplift: -57 lbs (plf)	
	PB03 1	Jnt-2 229.3" Gravity: 120 lbs (plf) Uplift: -60 lbs (plf)	
	PB04 12	Jnt-2 229.3" Gravity: 139 lbs (plf) Uplift: -76 lbs (plf)	
	PB05 4	Jnt-7 127.0" Gravity: 172 lbs (plf) Uplift: -105 lbs (plf)	
	PB06 1 (2Ply)	Jnt-2 229.3" Gravity: 137 lbs (plf) Uplift: -56 lbs (plf)	
	PB07 1	Jnt-1 121.9" Gravity: 99 lbs (plf) Uplift: -62 lbs (plf)	
	PB08 34	Jnt-2 121.9" Gravity: 186 lbs (plf) Uplift: -138 lbs (plf)	
	PB09 1	Jnt-2 141.2" Gravity: 119 lbs (plf) Uplift: -67 lbs (plf)	
	PB10 1	Jnt-1 121.9" Gravity: 99 lbs (plf) Uplift: -62 lbs (plf)	
	V01 1	Jnt-1 400.7" Gravity: 108 lbs (plf) Uplift: -51 lbs (plf)	

Builder: Amira Builders
Subdivision: SHORT RES.
Jurisdiction:
State: FL
Lot: N/A
Model: CUSTOM
Shipment: Roof
Elevation: GABLE
Option:

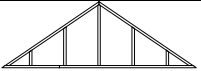
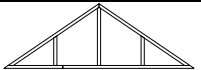
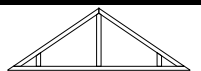
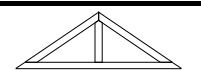
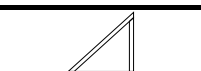
OnLine Job No:
Pick Ticket:
Sales No:
Acct No:
Ship Date: 12/25/2022
Designer: Conard, Ryan
AppWrt JobNo: 3039076

	V02 1	Jnt-1 336.7" Gravity: 125 lbs (plf) Uplift: -65 lbs (plf)	
	V03 1	Jnt-1 272.7" Gravity: 115 lbs (plf) Uplift: -57 lbs (plf)	
	V04 1	Jnt-1 208.7" Gravity: 110 lbs (plf) Uplift: -47 lbs (plf)	
	V05 1	Jnt-1 144.7" Gravity: 94 lbs (plf) Uplift: -52 lbs (plf)	
	V06 1	Jnt-1 80.7" Gravity: 86 lbs (plf) Uplift: -35 lbs (plf)	
	V07 1	Jnt-3 58.6" Gravity: 101 lbs (plf) Uplift: -41 lbs (plf)	
	V08 1	Jnt-3 40.6" Gravity: 99 lbs (plf) Uplift: -41 lbs (plf)	

Note: The reactions shown on this page are summarized from the Truss Design Drawings.
 Refer to the Project Truss Design Drawings for further details or verification.

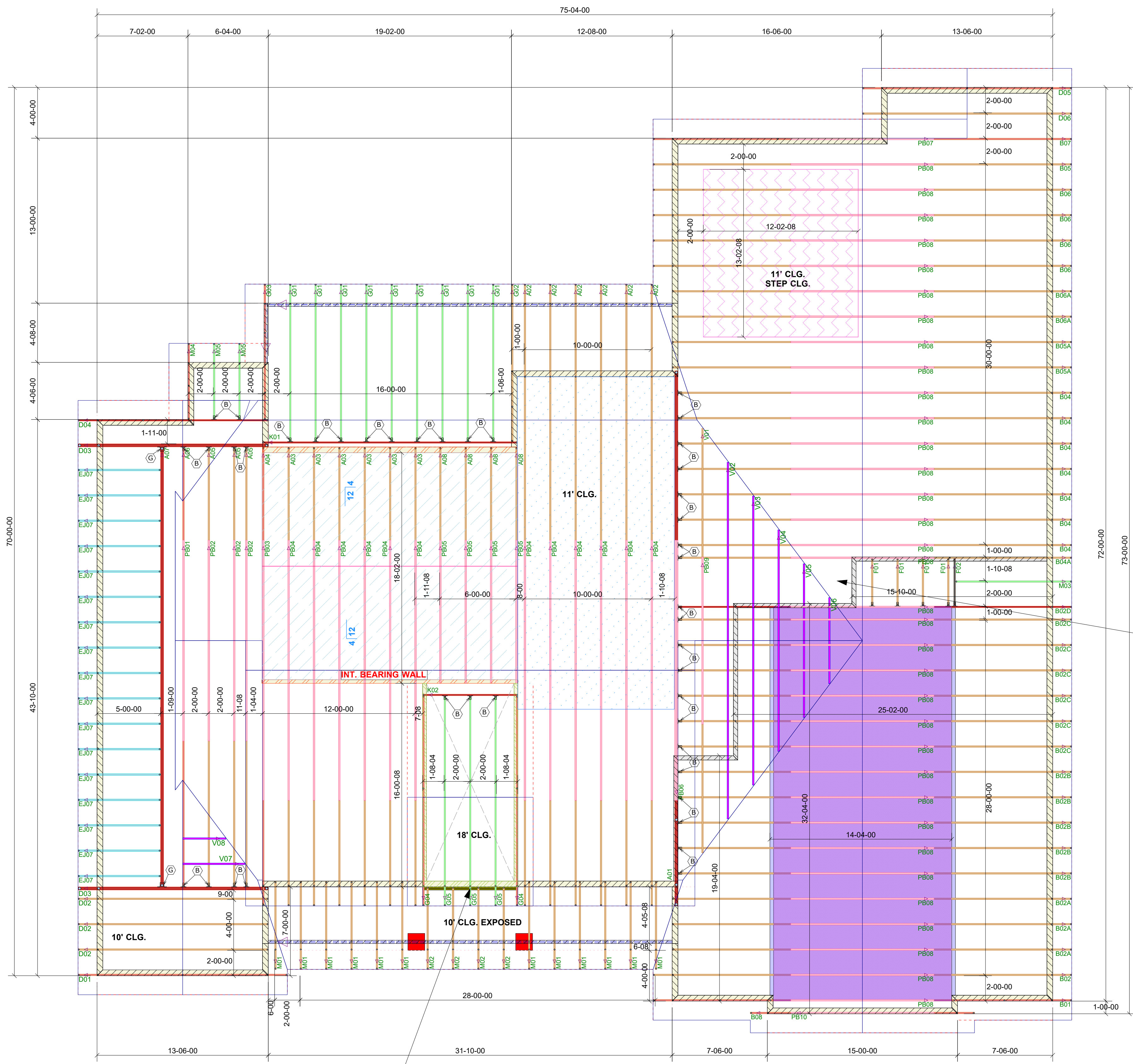

2x LEDGER ON 18" WALL BY OTHERS. OTHER MONO TRUSSES BEAR ON 10" WALL.

SOME INFILL FRAMING, ROOF LADDER FRAMING REQUIRED (BY OTHERS/FIELD FRAMED)

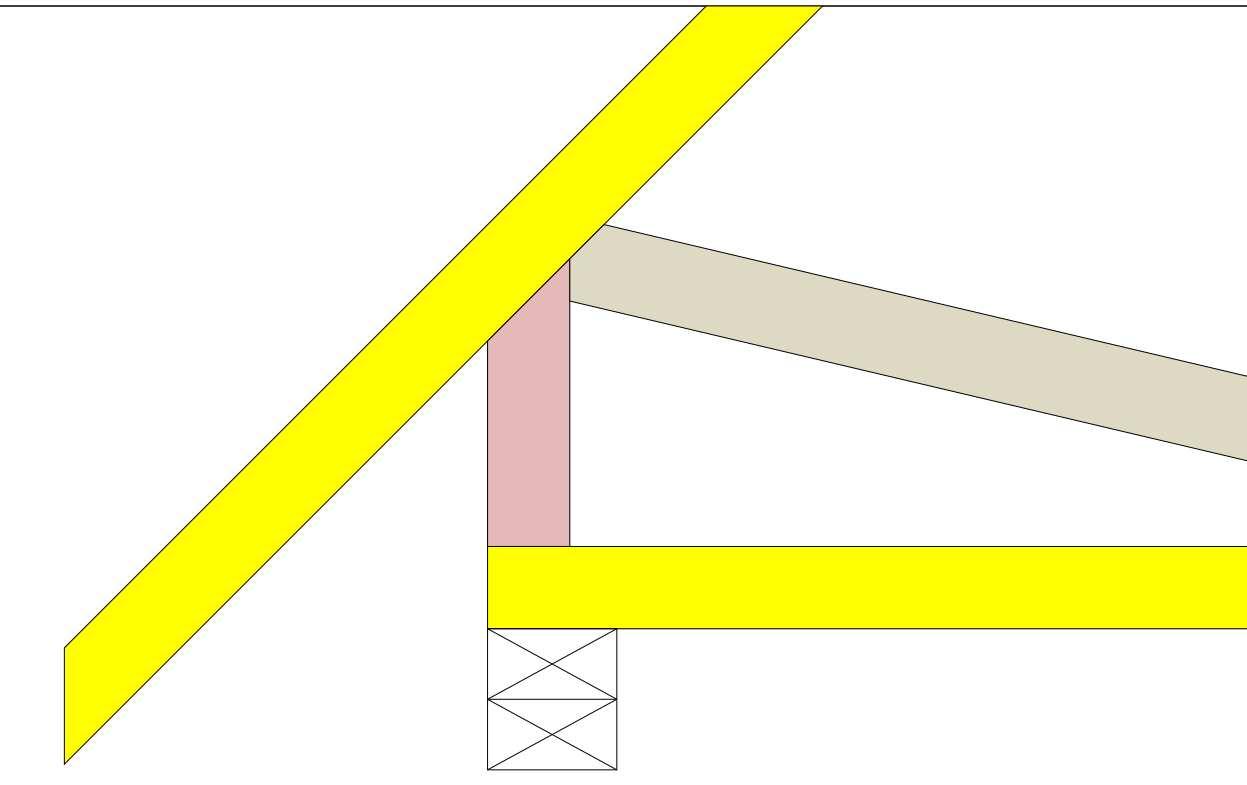

OVERHANG DETAIL: TOP CHORD OVERHANG

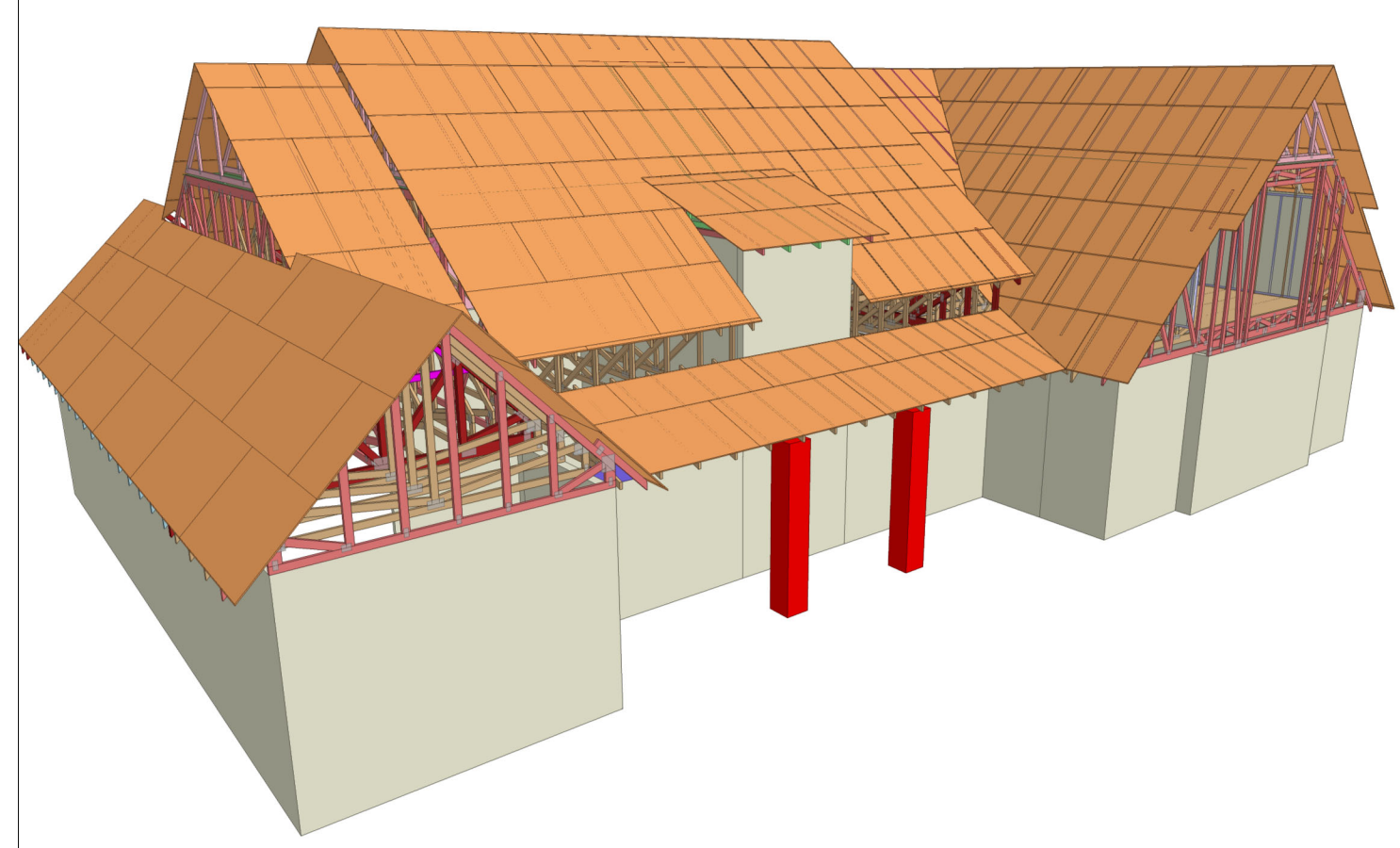

PROJECTION VIEW

SIMPSON CONNECTOR SCHEDULE
UNLESS OTHERWISE SPECIFIED BY EOR, TRUSS HANGERS LISTED HERE ARE REQUIRED.

ROOF TRUSS					
QTY	ID	MODEL	DOWN	UPLIFT	DETAIL
0	A	LUS24	1085	495	
42	B	HTU26	2945	1315	
0	C	HTU28	3060	2015	
0	D	HTU26-2	2555	1335	
0	E	HTU28-2	3890	2470	
0	F	HGUS26-2	5320	2155	
2	G	HGUS28-2	7460	3235	
0	H	HGUS26-3	5230	2155	
0	J	HGUS28-3	7460	3235	
0	K	HGUS28	9100	4095	
0	L	HGUS26	4500	1725	
0	M	THJA26	2940	915	
0	N	THJU26	1915	1310	

HANGER SCHEDULE

VERIFY ALL DIMENSIONS AND CEILING CONDITIONS PRIOR TO APPROVAL. SOME CEILING FRAMING REQUIRED IN FIELD BY BUILDER.

MAIN WIND FORCE RESISTING SYSTEM-C HYBRID WIND ASCE7-16
ENCLOSED EXPOSURE CATEGORY C
OCCUPANCY CATEGORY II
WIND LOAD 140 MPH
WIND IMPORTANCE FACTOR 1.00
TRUSSES HAVE BEEN DESIGNED FOR A 10.0 PSF BOTTOM CHORD LIVE LOAD NONCONCURRENT WITH ANY OTHER LIVE LOADS

ROOF LOADING		FLOOR LOADING	
TCLL:	20 PSF	TCLL:	10 PSF
TCDL:	10 PSF	TCDL:	5 PSF
BCDL:	10 PSF	BCDL:	40 PSF
TOTAL:	40 PSF	TOTAL:	55 PSF
DURATION:	1.25	DURATION:	1.0

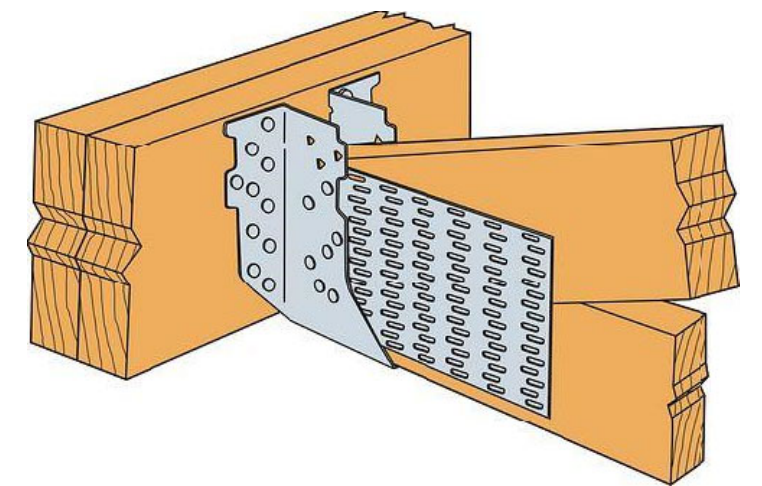

TYP. HTU26 NAILING INSTALLATION

IMPORTANT
This Drawing Must Be Approved And Returned Before Fabrication Will Begin. For Your Protection Check All Dimensions And Conditions Prior To Approval Of Plan.
SIGNATURE BELOW INDICATES ALL NOTES AND DIMENSIONS HAVE BEEN ACCEPTED.
By _____ Date _____

CAUTION!!!

DO NOT ATTEMPT TO ERECT TRUSSES WITHOUT REFERRING TO THE ENGINEERING DRAWINGS AND BSCI-B1 SUMMARY SHEETS.

ALL PERMANENT BRACING MUST BE IN PLACE PRIOR TO LOADING TRUSSES. (ie. SHEATHING, SHINGLES, ETC.)

ALL INTERIOR BEARING WALLS MUST BE IN PLACE PRIOR TO INSTALLING TRUSSES.

REFER TO FINAL ENGINEERING SHEETS FOR THE FOLLOWING.

- 1) NUMBER OF GIRDER PLIES AND NAILING SCHEDULE.
- 2) BEARING BLOCK REQUIREMENTS.
- 3) SCAB DETAILS (IF REQUIRED)
- 4) UPLIFT AND GRAVITY REACTIONS.

WARNING
Backcharges Will Not Be Accepted Regardless of Fault Without Prior Notification By Customer Within 48 Hours And Investigation By Builders FirstSource. NO EXCEPTIONS.

The General Contractor Is Responsible For All Connections Other Than Truss to Truss, Gable Shear Wall, And Connections. Temporary and Permanent Bracing, And Ceiling And Roof Diaphragm Connections.

- ROOF PITCH: 4, 9, 12/12
- CEILING PITCH: 4/12
- TOP CHORD SIZE: 2 X 4
- BOTTOM CHORD SIZE: VARIES
- OVERHANG LENGTH: 18"
- END CUT: PLUMB
- CANTILEVER: 0
- TRUSS SPACING: 24"
- BUILDING CODE: FBC2020

BEARING HEIGHT SCHEDULE

Hatch Legend	
[Hatch]	12" STEP UP CLG.
[Hatch]	11' CLG. HGT
[Hatch]	4/12 VAULT CLG.
[Hatch]	10' BRG. HGT
[Hatch]	13' BRG. HGT
[Hatch]	18' BRG. HGT

BUILDER: AMIRA BUILDERS

PROJECT: SHORT RESIDENCE

MODEL: CUSTOM

ADDRESS: TBD SE CR 349

LOT / BLOCK:

SUBDIVISION:

CITY: LAKE CITY

DRAWN BY: RYAN CONARD

JOB #: 3039076

DATE: 2/20/2022 **SCALE:** N/A

- PLAN DATE:** 2/2/2022
- REVISIONS:**
- 1.
 - 2.
 - 3.
 - 4.



4408 Airport Road
Plant City, FL 33567
Phone (813) 305-1300
Fax (813) 305-1301

SHEET SIZE: ARCH D (24" X 36")



Lumber design values are in accordance with ANSI/TPI 1 section 6.3
 These truss designs rely on lumber values established by others.

RE: 3039076 -

MiTek USA, Inc.
 6904 Parke East Blvd.
 Tampa, FL 33610-4115

Site Information:

Customer Info: Amira Builders Project Name: Short Res. Model: Custom
 Lot/Block: . Subdivision: Short Res.
 Address: Tbd SE Cr 349, .
 City: Lake City State: FL

Name Address and License # of Structural Engineer of Record, If there is one, for the building.

Name: License #:
 Address:
 City: State:

General Truss Engineering Criteria & Design Loads (Individual Truss Design Drawings Show Special Loading Conditions):

Design Code: FBC2020/TPI2014 Design Program: MiTek 20/20 8.5
 Wind Code: ASCE 7-16 Wind Speed: 140 mph
 Roof Load: 40.0 psf Floor Load: N/A psf

This package includes 61 individual, Truss Design Drawings and 0 Additional Drawings.
 With my seal affixed to this sheet, I hereby certify that I am the Truss Design Engineer and this index sheet conforms to 61G15-31.003, section 5 of the Florida Board of Professional Engineers Rules.

No.	Seal#	Truss Name	Date	No.	Seal#	Truss Name	Date
1	T27365398	A01	4/7/22	23	T27365420	D01	4/7/22
2	T27365399	A02	4/7/22	24	T27365421	D02	4/7/22
3	T27365400	A03	4/7/22	25	T27365422	D03	4/7/22
4	T27365401	A04	4/7/22	26	T27365423	D04	4/7/22
5	T27365402	A05	4/7/22	27	T27365424	D05	4/7/22
6	T27365403	A06	4/7/22	28	T27365425	D06	4/7/22
7	T27365404	A07	4/7/22	29	T27365426	EJ07	4/7/22
8	T27365405	A08	4/7/22	30	T27365427	F01	4/7/22
9	T27365406	B01	4/7/22	31	T27365428	F02	4/7/22
10	T27365407	B02	4/7/22	32	T27365429	G01	4/7/22
11	T27365408	B02A	4/7/22	33	T27365430	G02	4/7/22
12	T27365409	B02B	4/7/22	34	T27365431	G03	4/7/22
13	T27365410	B02C	4/7/22	35	T27365432	G04	4/7/22
14	T27365411	B02D	4/7/22	36	T27365433	G05	4/7/22
15	T27365412	B04	4/7/22	37	T27365434	K01	4/7/22
16	T27365413	B04A	4/7/22	38	T27365435	K02	4/7/22
17	T27365414	B05	4/7/22	39	T27365436	M01	4/7/22
18	T27365415	B05A	4/7/22	40	T27365437	M02	4/7/22
19	T27365416	B06	4/7/22	41	T27365438	M03	4/7/22
20	T27365417	B06A	4/7/22	42	T27365439	M04	4/7/22
21	T27365418	B07	4/7/22	43	T27365440	M05	4/7/22
22	T27365419	B08	4/7/22	44	T27365441	PB01	4/7/22



The truss drawing(s) referenced above have been prepared by MiTek USA, Inc. under my direct supervision based on the parameters provided by Builders FirstSource (Groveland, FL).

Truss Design Engineer's Name: Velez, Joaquin
 My license renewal date for the state of Florida is February 28, 2023.

IMPORTANT NOTE: The seal on these truss component designs is a certification that the engineer named is licensed in the jurisdiction(s) identified and that the designs comply with ANSI/TPI 1. These designs are based upon parameters shown (e.g., loads, supports, dimensions, shapes and design codes), which were given to MiTek or TRENCO. Any project specific information included is for MiTek's or TRENCO's customers file reference purpose only, and was not taken into account in the preparation of these designs. MiTek or TRENCO has not independently verified the applicability of the design parameters or the designs for any particular building. Before use, the building designer should verify applicability of design parameters and properly incorporate these designs into the overall building design per ANSI/TPI 1, Chapter 2.

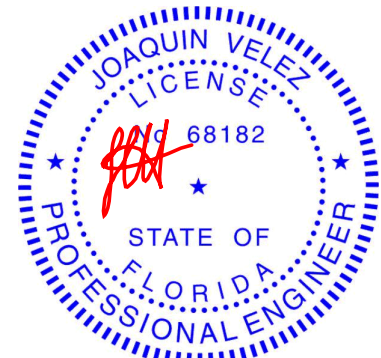

Joaquin Velez PE No.68182
 MiTek USA, Inc. FL Cert 6634
 6904 Parke East Blvd. Tampa FL 33610
 Date:

April 7, 2022



RE: 3039076 -

MiTek USA, Inc.
6904 Parke East Blvd.
Tampa, FL 33610-4115

Site Information:

Customer Info: Amira Builders Project Name: Short Res. Model: Custom
Lot/Block: . Subdivision: Short Res.
Address: Tbd SE Cr 349, .
City: Lake City State: FL

No.	Seal#	Truss Name	Date
45	T27365442	PB02	4/7/22
46	T27365443	PB03	4/7/22
47	T27365444	PB04	4/7/22
48	T27365445	PB05	4/7/22
49	T27365446	PB06	4/7/22
50	T27365447	PB07	4/7/22
51	T27365448	PB08	4/7/22
52	T27365449	PB09	4/7/22
53	T27365450	PB10	4/7/22
54	T27365451	V01	4/7/22
55	T27365452	V02	4/7/22
56	T27365453	V03	4/7/22
57	T27365454	V04	4/7/22
58	T27365455	V05	4/7/22
59	T27365456	V06	4/7/22
60	T27365457	V07	4/7/22
61	T27365458	V08	4/7/22

Job 3039076	Truss A01	Truss Type Piggyback Base Girder	Qty 1	Ply 2	Job Reference (optional) T27365398
----------------	--------------	-------------------------------------	----------	----------	---------------------------------------

Builders FirstSource (Groveland, FL), Groveland, FL - 34736,

Run: 8.53 S Dec 6 2021 Print: 8.530 S Dec 6 2021 MiTek Industries, Inc. Wed Apr 06 15:09:49

Page: 1

ID:QuUAc7_m?wpkycs7uxJsmxzTRNR-RfC?PsB70Hq3NSgPqnL8w3ulTXbGKwKDCoi7J4zJC?f

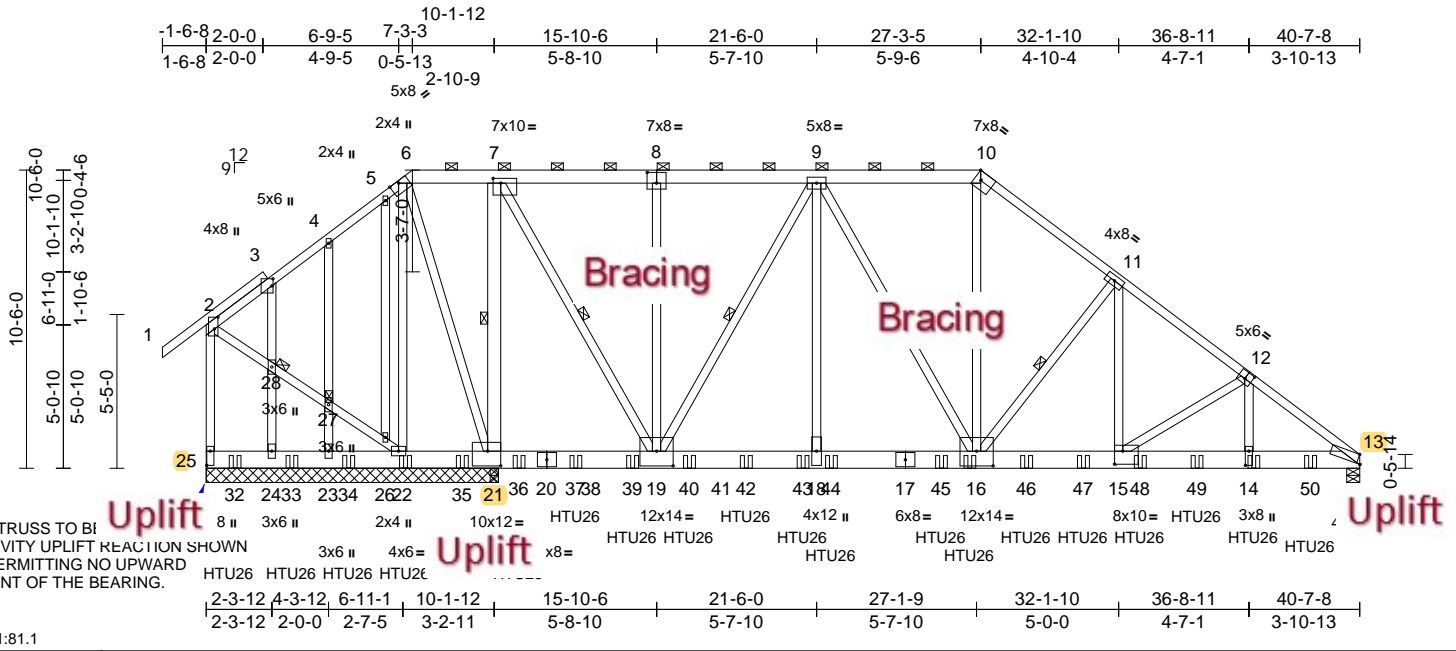

FASTEN TRUSS TO BE THE GRAVITY UPLIFT REACTION SHOWN WHILE PERMITTING NO UPWARD MOVEMENT OF THE BEARING.

Scale = 1:81.1

[2:0-5-0,0-1-8], [3:0-3-0,0-0-8], [7:0-3-4,0-2-0], [8:0-4-0,0-4-8], [12:0-3-0,0-3-0], [13:0-1-8,Edge], [14:0-6-0,0-1-8], [15:0-3-8,0-5-8], [16:0-7-0,0-6-4], [19:0-7-0,0-6-4],

Plate Offsets (X, Y): [21:0-5-8,0-6-4], [25:0-6-0,0-1-8]

Loading	(psf)	Spacing	2-0-0	CSI	DEFL	in	(loc)	l/defl	L/d	PLATES	GRIP	
TCLL (roof)	20.0	Plate Grip DOL	1.25	TC	0.88	Vert(LL)	-0.19	15-16	>999	360	MT20	244/190
TCDL	10.0	Lumber DOL	1.25	BC	0.45	Vert(CT)	-0.36	15-16	>999	240		
BCLL	0.0*	Rep Stress Incr	NO	WB	1.00	Horz(CT)	0.05	13	n/a	n/a		
BCDL	10.0	Code	FBC2020/TPI2014	Matrix-MS		Wind(LL)	0.22	15-16	>999	240	Weight: 881 lb	FT = 20%

LUMBER
TOP CHORD 2x4 SP No.2 *Except* 6-8,8-10:2x6 SP No.2
BOT CHORD 2x8 SP 2400F 2.0E
WEBS 2x4 SP No.3 *Except* 21-7:2x6 SP No.2, 9-16,19-7,19-9:2x4 SP M 31
OTHERS
2x4 SP No.3

BRACING
TOP CHORD Structural wood sheathing directly applied or 2-5-2 oc purlins, except end verticals, and 2-0-0 oc purlins (5-8-10 max.): 6-10.
BOT CHORD Rigid ceiling directly applied or 10-0-0 oc bracing, Except: 6-0-0 oc bracing: 21-22,19-21.
WEBS 1 Row at midpt 11-16, 7-21, 7-19, 9-19
JOINTS
1 Brace at Jt(s): 27, 28

REACTIONS (lb/size) 13=8903/0-5-8, 21=17141/10-3-8, 22=27177/10-3-8, 23=1686/10-3-8, 24=2064/10-3-8, 25=-1956/10-3-8
Max Horiz 25=-485 (LC 6)
Max Uplift 13=-3598 (LC 9), 21=-6453 (LC 4), 22=-404 (LC 8), 23=-331 (LC 8), 24=-335 (LC 8), 25=-2200 (LC 23)
Max Grav 13=9738 (LC 23), 21=19442 (LC 17), 22=3167 (LC 2), 23=2007 (LC 22), 24=2433 (LC 2), 25=1043 (LC 5)

FORCES (lb) - Maximum Compression/Maximum Tension
TOP CHORD 1-2=0/54, 2-3=-1092/2884, 3-4=-955/2785, 4-5=-1017/2991, 5-6=-995/2930, 6-7=-1025/3001, 7-9=-3632/1303, 9-10=-7413/2880, 10-11=-9237/3450, 11-13=-14590/5377, 2-25=-1105/3098

NOTES
1) 2-ply truss to be connected together with 10d (0.131"x3") nails as follows:
Top chords connected as follows: 2x4 - 1 row at 0-9-0 oc, 2x6 - 2 rows staggered at 0-9-0 oc.
Bottom chords connected as follows: 2x8 - 3 rows staggered at 0-6-0 oc.
Web connected as follows: 2x4 - 1 row at 0-9-0 oc, Except member 12-14 2x4 - 2 rows staggered at 0-9-0 oc, 2x6 - 2 rows staggered at 0-9-0 oc.
2) All loads are considered equally applied to all plies, except if noted as front (F) or back (B) face in the LOAD CASE(S) section. Ply to ply connections have been provided to distribute only loads noted as (F) or (B), unless otherwise indicated.
3) Unbalanced roof live loads have been considered for this design.
4) Wind: ASCE 7-16; Vult=140mph (3-second gust) Vasd=108mph; TCDL=4.2psf; BCDL=5.0psf; h=25ft; Cat. II; Exp C; Enclosed; MWFRS (envelope) exterior zone; end vertical left and right exposed; Lumber DOL=1.60 plate grip DOL=1.60

- Truss designed for wind loads in the plane of the truss only. For studs exposed to wind (normal to the face), see Standard Industry Gable End Details as applicable, or consult qualified building designer as per ANSI/TPI 1.
- Building Designer / Project engineer responsible for verifying applied roof live load shown covers rain loading requirements specific to the use of this truss component.
- Provide adequate drainage to prevent water ponding.
- Gable studs spaced at 2-0-0 oc.
- This truss has been designed for a 10.0 psf bottom chord live load nonconcurrent with any other live loads.
- * This truss has been designed for a live load of 20.0psf on the bottom chord in all areas where a rectangle 3-06-00 tall by 2-00-00 wide will fit between the bottom chord and any other members, with BCDL = 10.0psf.
- Provide mechanical connection (by others) of truss to bearing plate capable of withstanding 2200 lb uplift at joint 25, 404 lb uplift at joint 22, 3598 lb uplift at joint 13, 6453 lb uplift at joint 21, 435 lb uplift at joint 24 and 331 lb uplift at joint 23.

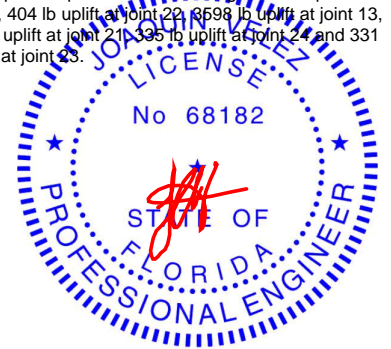

Joaquin Velez PE No.68182
MiTek USA, Inc. FL Cert 6634
6904 Parke East Blvd. Tampa FL 33610
Date:

April 7, 2022

Continued on page 2

WARNING - Verify design parameters and READ NOTES ON THIS AND INCLUDED MITEK REFERENCE PAGE MII-7473 rev. 5/19/2020 BEFORE USE.

Design valid for use only with MiTek® connectors. This design is based only upon parameters shown, and is for an individual building component, not a truss system. Before use, the building designer must verify the applicability of design parameters and properly incorporate this design into the overall building design. Bracing indicated is to prevent buckling of individual truss web and/or chord members only. Additional temporary and permanent bracing is always required for stability and to prevent collapse with possible personal injury and property damage. For general guidance regarding the fabrication, storage, delivery, erection and bracing of trusses and truss systems, see **ANSI/TPI1 Quality Criteria, DSB-89 and BCSI Building Component Safety Information** available from Truss Plate Institute, 2670 Crain Highway, Suite 203 Waldorf, MD 20601



6904 Parke East Blvd.
Tampa, FL 33610

Job 3039076	Truss A01	Truss Type Piggyback Base Girder	Qty 1	Ply 2	Job Reference (optional) T27365398
----------------	--------------	-------------------------------------	----------	----------	---------------------------------------

Builders FirstSource (Groveland, FL), Groveland, FL - 34736,

Run: 8.53 S Dec 6 2021 Print: 8.530 S Dec 6 2021 MiTek Industries, Inc. Wed Apr 06 15:09:49
ID:qUuAc7_m?wpkcys7uxJsMxzTRNR-RfC?PsB70Hq3NSgPqnL8w3ulTXbGKWrCDoi7J4zJC?f

Page: 2

- 12) Graphical purlin representation does not depict the size or the orientation of the purlin along the top and/or bottom chord.
- 13) This truss has large uplift reaction(s) from gravity load case(s) at jt 25. Proper connection is required to secure truss against upward movement at the bearings. Building designer must provide for uplift reactions indicated at jt 25.
- 14) Use Simpson Strong-Tie HTU26 (20-10d Girder, 11-10dx1 1/2 Truss, Single Ply Girder) or equivalent spaced at 3-10-8 oc max. starting at 1-0-4 from the left end to 38-10-12 to connect truss(es) to front face of bottom chord.
- 15) Fill all nail holes where hanger is in contact with lumber.

LOAD CASE(S) Standard

- 1) Dead + Roof Live (balanced): Lumber Increase=1.25,
Plate Increase=1.25
Uniform Loads (lb/ft)

Vert: 1-2=-60, 2-6=-60, 6-10=-60, 10-13=-60,
25-29=-20

Concentrated Loads (lb)

Vert: 22=-1582 (F), 16=-1144 (F), 14=-1144 (F),
32=-1583 (F), 33=-1582 (F), 34=-1582 (F), 35=-1582 (F),
36=-1488 (F), 37=-1488 (F), 39=-1488 (F),
40=-1488 (F), 42=-1488 (F), 43=-1488 (F), 44=-1851 (F),
45=-514 (F), 46=-1144 (F), 47=-1144 (F),
48=-1144 (F), 49=-1144 (F), 50=-1144 (F)

WARNING - Verify design parameters and READ NOTES ON THIS AND INCLUDED MITEK REFERENCE PAGE MII-7473 rev. 5/19/2020 BEFORE USE.

Design valid for use only with MiTek® connectors. This design is based only upon parameters shown, and is for an individual building component, not a truss system. Before use, the building designer must verify the applicability of design parameters and properly incorporate this design into the overall building design. Bracing indicated is to prevent buckling of individual truss web and/or chord members only. Additional temporary and permanent bracing is always required for stability and to prevent collapse with possible personal injury and property damage. For general guidance regarding the fabrication, storage, delivery, erection and bracing of trusses and truss systems, see **ANSI/TPI1 Quality Criteria, DSB-89 and BCSI Building Component Safety Information** available from Truss Plate Institute, 2670 Crain Highway, Suite 203 Waldorf, MD 20601



6904 Parke East Blvd.
Tampa, FL 36610

Job 3039076	Truss A02	Truss Type Piggyback Base	Qty 6	Ply 1	Job Reference (optional) T27365399
----------------	--------------	------------------------------	----------	----------	---------------------------------------

Builders FirstSource (Groveland, FL), Groveland, FL - 34736,

Run: 8:53 S Dec 6 2021 Print: 8:53 S Dec 6 2021 MiTek Industries, Inc. Wed Apr 06 15:09:51

Page: 1

ID:hYII?qNZfzrjAKVypk0kNpzTPoE-RfC?PsB70Hq3NSgPqnL8w3uITXbGKWRcDoi7J4zJc?f

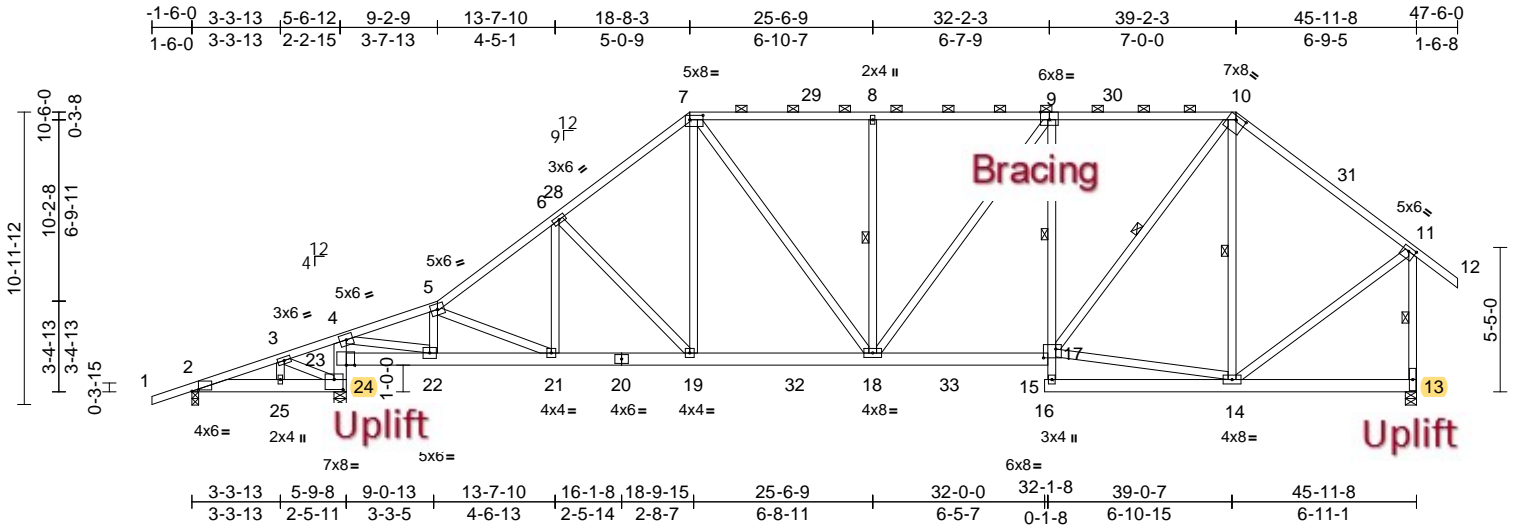

Scale = 1:86.5

Plate Offsets (X, Y): [2:0-2-14,0-0-9], [7:0-6-0,0-2-0], [9:0-4-0,Edge], [10:0-4-8,0-1-12], [11:0-3-0,0-1-12], [17:0-5-8,0-4-0], [23:0-3-12,Edge], [24:0-4-0,0-4-8]

Loading	(psf)	Spacing	2-0-0	CSI	DEFL	in	(loc)	l/defl	L/d	PLATES	GRIP	
TCLL (roof)	20.0	Plate Grip DOL	1.25	TC	0.77	Vert(LL)	-0.14	17-18	>999	360	MT20	244/190
TCDL	10.0	Lumber DOL	1.25	BC	0.52	Vert(CT)	-0.25	17-18	>999	240		
BCLL	0.0*	Rep Stress Incr	YES	WB	0.97	Horz(CT)	0.07	13	n/a	n/a		
BCDL	10.0	Code	FBC2020/TPI2014	Matrix-AS		Wind(LL)	0.14	18	>999	240	Weight: 360 lb	FT = 20%

LUMBER
TOP CHORD 2x4 SP No.2
BOT CHORD 2x6 SP No.2 *Except* 9-15:2x4 SP No.3
WEBS 2x4 SP No.3 *Except* 22-4:2x4 SP No.2

BRACING
TOP CHORD Structural wood sheathing directly applied, except end verticals, and 2-0-0 oc purlins (3-7-11 max.): 7-10.
BOT CHORD Rigid ceiling directly applied. Except: 1 Row at midpt 9-17
10-0-0 oc bracing: 15-17

WEBS
1 Row at midpt 8-18, 10-17, 10-14, 11-13

REACTIONS (lb/size)
2=132/0-3-0, 13=1690/0-5-0, 24=2037/0-5-8
Max Horiz 2=552 (LC 9)
Max Uplift 2=346 (LC 6), 13=545 (LC 6), 24=857 (LC 7)
Max Grav 2=135 (LC 21), 13=1836 (LC 2), 24=2241 (LC 2)

FORCES (lb) - Maximum Compression/Maximum Tension
TOP CHORD 1-2=0/31, 2-3=427/578, 3-4=608/783, 4-5=2407/1232, 5-6=2565/1397, 6-7=2177/1324, 7-8=1968/1309, 8-10=1968/1309, 10-11=1337/938, 11-12=0/61, 11-13=1735/1163
BOT CHORD 2-25=378/82, 24-25=378/65, 23-24=2115/1074, 4-23=1878/989, 22-23=741/579, 21-22=945/2298, 19-21=912/2026, 18-19=794/1687, 17-18=828/1814, 15-17=0/145, 9-17=639/494, 15-16=0/0, 14-15=36/94, 13-14=116/99

WEBS
4-22=1507/3060, 5-22=771/505, 7-19=261/676, 7-18=403/546, 8-18=430/379, 9-18=137/297, 14-17=384/907, 10-17=676/1353, 10-14=663/438, 11-14=460/1214, 6-19=601/446, 6-21=67/339, 5-21=300/212, 3-24=379/601, 3-25=321/199

NOTES
1) Unbalanced roof live loads have been considered for this design.
2) Wind: ASCE 7-16; Vult=140mph (3-second gust) Vasd=108mph; TCCL=4.2psf; BCCL=5.0psf; h=25ft; Cat. II; Exp C; Enclosed; MWFRS (envelope) exterior zone and C-C Exterior(2E) -1-6-0 to 3-3-13, Interior (1) 3-3-13 to 14-1-0, Exterior(2R) 14-1-0 to 23-3-5, Interior (1) 23-3-5 to 34-7-0, Exterior(2R) 34-7-0 to 42-10-14, Exterior(2E) 42-10-14 to 47-6-0 zone; end vertical left and right exposed; porch left exposed; C-C for members and forces & MWFRS for reactions shown; Lumber DOL=1.60 plate grip DOL=1.60
3) Building Designer / Project engineer responsible for verifying applied roof live load shown covers rain loading requirements specific to the use of this truss component.
4) Provide adequate drainage to prevent water ponding.
5) This truss has been designed for a 10.0 psf bottom chord live load nonconcurrent with any other live loads.
6) * This truss has been designed for a live load of 20.0psf on the bottom chord in all areas where a rectangle 3-06-00 tall by 2-00-00 wide will fit between the bottom chord and any other members, with BCCL = 10.0psf.
7) Provide mechanical connection (by others) of truss to bearing plate capable of withstanding 346 lb uplift at joint 2, 545 lb uplift at joint 13 and 857 lb uplift at joint 24.

8) This truss design requires that a minimum of 7/16" structural wood sheathing be applied directly to the top chord and 1/2" gypsum sheetrock be applied directly to the bottom chord.
9) Graphical purlin representation does not depict the size or the orientation of the purlin along the top and/or bottom chord.
LOAD CASE(S) Standard

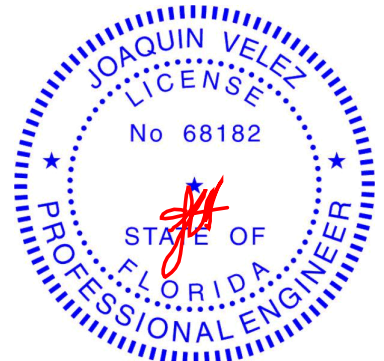

Joaquin Velez PE No.68182
MiTek USA, Inc. FL Cert 6634
6904 Parke East Blvd. Tampa FL 33610
Date:

April 7, 2022

WARNING - Verify design parameters and READ NOTES ON THIS AND INCLUDED MITEK REFERENCE PAGE MII-7473 rev. 5/19/2020 BEFORE USE.

Design valid for use only with MiTek® connectors. This design is based only upon parameters shown, and is for an individual building component, not a truss system. Before use, the building designer must verify the applicability of design parameters and properly incorporate this design into the overall building design. Bracing indicated is to prevent buckling of individual truss web and/or chord members only. Additional temporary and permanent bracing is always required for stability and to prevent collapse with possible personal injury and property damage. For general guidance regarding the fabrication, storage, delivery, erection and bracing of trusses and truss systems, see **ANSI/TPI1 Quality Criteria, DSB-89 and BCSI Building Component Safety Information** available from Truss Plate Institute, 2670 Crain Highway, Suite 203 Waldorf, MD 20601



6904 Parke East Blvd.
Tampa, FL 33610

Job 3039076	Truss A03	Truss Type Piggyback Base	Qty 6	Ply 1	Job Reference (optional)	T27365400
----------------	--------------	------------------------------	----------	----------	--------------------------	-----------

Builders FirstSource (Groveland, FL), Groveland, FL - 34736,

Run: 8.53 S Dec 6 2021 Print: 8.530 S Dec 6 2021 MiTek Industries, Inc. Wed Apr 06 15:09:52
ID:N4rR0T6K6fOi0BiH9ilz_zTRZk-RfC?PsB70Hq3NSgPqnl8w3uITXbGKWRCDoi7J4zJC?f

Page: 1

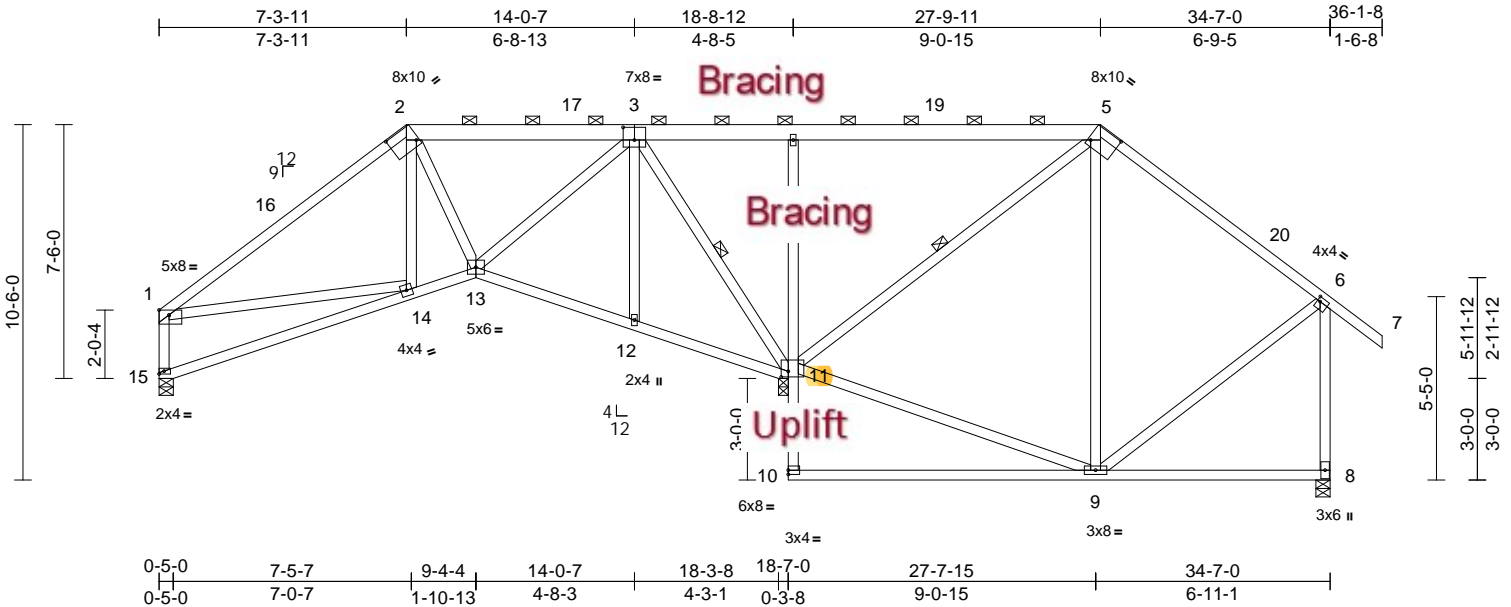

Scale = 1:68.1
Plate Offsets (X, Y): [1:Edge,0-1-12], [2:0-9-0,0-6-0], [3:0-4-0,0-4-8], [5:0-9-0,0-6-0], [6:0-1-0,0-1-8], [11:0-2-8,0-2-0]

Loading	(psf)	Spacing	2-0-0	CSI	DEFL	in	(loc)	l/defl	L/d	PLATES	GRIP
TCLL (roof)	20.0	Plate Grip DOL	1.25	TC	0.70	Vert(LL)	-0.14	9-10	>999	360	MT20 244/190
TCDL	10.0	Lumber DOL	1.25	BC	0.62	Vert(CT)	-0.29	9-10	>652	240	
BCLL	0.0*	Rep Stress Incr	YES	WB	0.41	Horz(CT)	-0.03	8	n/a	n/a	
BCDL	10.0	Code	FBC2020/TPI2014	Matrix-AS		Wind(LL)	0.03	13	>999	240	Weight: 264 lb FT = 20%

LUMBER
TOP CHORD 2x4 SP No.2 *Except* 2-3,3-5:2x6 SP No.2
BOT CHORD 2x4 SP No.2 *Except* 4-10:2x4 SP No.3
WEBS 2x4 SP No.3

BRACING
TOP CHORD Structural wood sheathing directly applied, except end verticals, and 2-0-0 oc purlins (6-0-0 max.): 2-5.
BOT CHORD Rigid ceiling directly applied.
WEBS 1 Row at midpt 3-11, 5-11

REACTIONS (lb/size) 8=546/0-5-0, 11=1715/0-3-8, 15=583/0-5-0
Max Horiz 15=462 (LC 9)
Max Uplift 8=345 (LC 11), 11=890 (LC 7), 15=323 (LC 10)
Max Grav 8=621 (LC 18), 11=1715 (LC 1), 15=588 (LC 21)

FORCES (lb) - Maximum Compression/Maximum Tension
TOP CHORD 1-2=-754/340, 2-4=-463/363, 4-5=-241/359, 5-6=-409/409, 6-7=0/61, 1-15=-556/374, 6-8=-572/457
BOT CHORD 14-15=-464/512, 13-14=-464/629, 12-13=-238/326, 11-12=-230/328, 10-11=0/165, 4-11=-504/447, 9-10=0/50, 8-9=-103/109
WEBS 2-14=0/192, 2-13=-117/170, 3-13=-347/559, 3-11=-836/489, 9-11=-90/168, 5-11=-640/261, 5-9=-21/248, 1-14=-96/382, 6-9=0/186, 3-12=0/217

NOTES
1) Unbalanced roof live loads have been considered for this design.

- 2) Wind: ASCE 7-16; Vult=140mph (3-second gust) Vasd=108mph; TCDL=4.2psf; BCDL=5.0psf; h=25ft; Cat. II; Exp C; Enclosed; MWFRS (envelope) exterior zone and C-C Exterior(2E) 0-2-4 to 3-7-12, Exterior(2R) 3-7-12 to 12-2-14, Interior (1) 12-2-14 to 22-11-8, Exterior(2R) 22-11-8 to 32-8-8, Exterior(2E) 32-8-8 to 36-2-0 zone; end vertical left and right exposed; C-C for members and forces & MWFRS for reactions shown; Lumber DOL=1.60 plate grip DOL=1.60
- 3) Building Designer / Project engineer responsible for verifying applied roof live load shown covers rain loading requirements specific to the use of this truss component.
- 4) Provide adequate drainage to prevent water ponding.
- 5) This truss has been designed for a 10.0 psf bottom chord live load nonconcurrent with any other live loads.
- 6) * This truss has been designed for a live load of 20.0psf on the bottom chord in all areas where a rectangle 3-06-00 tall by 2-00-00 wide will fit between the bottom chord and any other members.
- 7) Bearing at joint(s) 15, 11 considers parallel to grain value using ANSI/TPI 1 angle to grain formula. Building designer should verify capacity of bearing surface.
- 8) Provide mechanical connection (by others) of truss to bearing plate capable of withstanding 323 lb uplift at joint 15, 345 lb uplift at joint 8 and 890 lb uplift at joint 11.
- 9) This truss design requires that a minimum of 7/16" structural wood sheathing be applied directly to the top chord and 1/2" gypsum sheetrock be applied directly to the bottom chord.
- 10) Graphical purlin representation does not depict the size or the orientation of the purlin along the top and/or bottom chord.

LOAD CASE(S) Standard

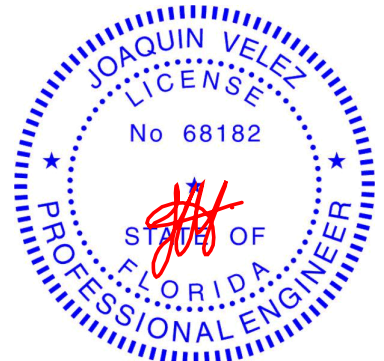

Joaquin Velez PE No.68182
MiTek USA, Inc. FL Cert 6634
6904 Parke East Blvd. Tampa FL 33610
Date:

April 7, 2022

WARNING - Verify design parameters and READ NOTES ON THIS AND INCLUDED MITEK REFERENCE PAGE MII-7473 rev. 5/19/2020 BEFORE USE.

Design valid for use only with MiTek® connectors. This design is based only upon parameters shown, and is for an individual building component, not a truss system. Before use, the building designer must verify the applicability of design parameters and properly incorporate this design into the overall building design. Bracing indicated is to prevent buckling of individual truss web and/or chord members only. Additional temporary and permanent bracing is always required for stability and to prevent collapse with possible personal injury and property damage. For general guidance regarding the fabrication, storage, delivery, erection and bracing of trusses and truss systems, see ANSITPI1 Quality Criteria, DSB-89 and BCSI Building Component Safety Information available from Truss Plate Institute, 2670 Crain Highway, Suite 203 Waldorf, MD 20601



6904 Parke East Blvd.
Tampa, FL 33610

Job 3039076	Truss A04	Truss Type Piggyback Base Structural Gable	Qty 1	Ply 1	Job Reference (optional) T27365401
----------------	--------------	---	----------	----------	---------------------------------------

Builders FirstSource (Groveland, FL), Groveland, FL - 34736,

Run: 8:53 S Dec 6 2021 Print: 8:53 S Dec 6 2021 MiTek Industries, Inc. Wed Apr 06 15:09:52

Page: 1

ID:q8lvnP2bimRNfoq3twCYdjzTRjJ-RfC?PsB70Hq3NSgPqL8w3uITXbGKWRCoI7J4zJC?F

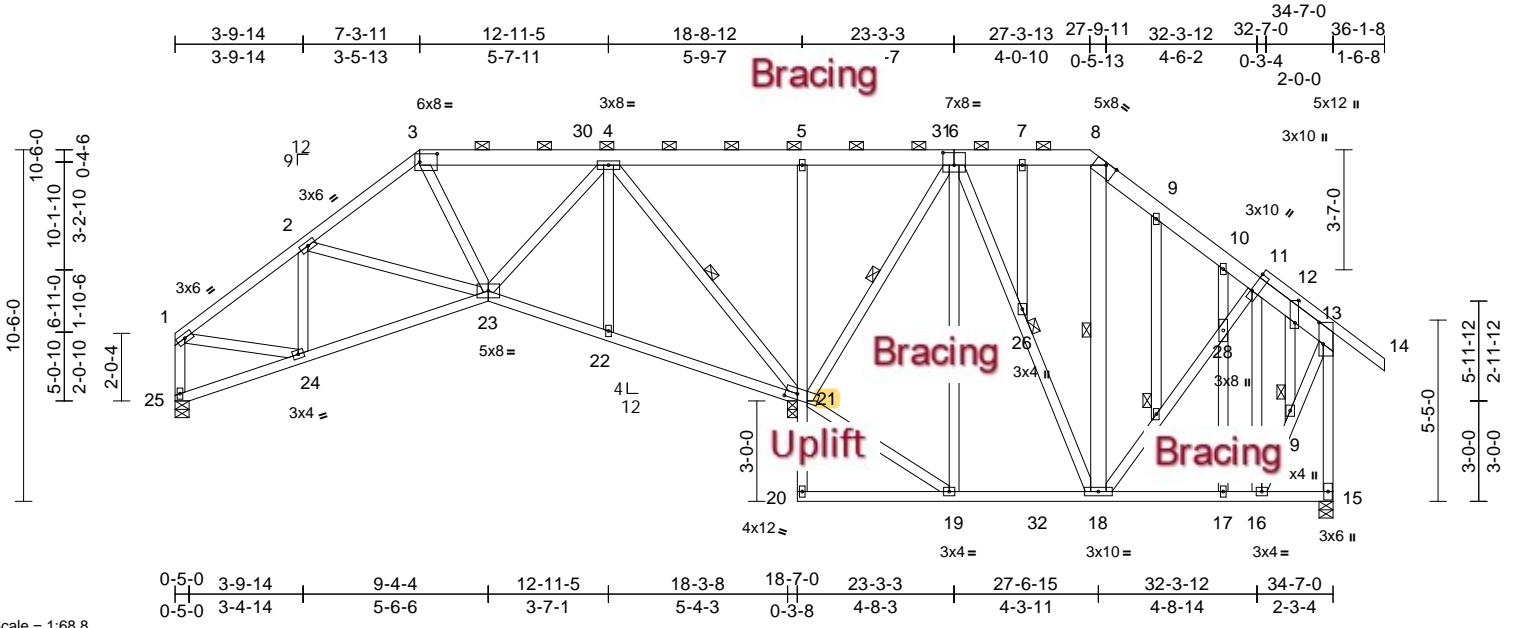

Scale = 1:68.8

Plate Offsets (X, Y): [3:0-6-4,0-2-15], [6:0-4-0,0-4-8], [11:Edge,0-0-8], [12:0-8-1,0-1-4], [13:0-7-12,0-1-8], [21:0-4-4,0-2-0]

Loading	(psf)	Spacing	2-0-0	CSI	DEFL	in	(loc)	l/defl	L/d	PLATES	GRIP	
TCLL (roof)	20.0	Plate Grip DOL	1.25	TC	0.40	Vert(LL)	-0.04	23-24	>999	360	MT20	244/190
TCDL	10.0	Lumber DOL	1.25	BC	0.28	Vert(CT)	-0.08	23-24	>999	240		
BCLL	0.0*	Rep Stress Incr	YES	WB	0.44	Horz(CT)	-0.03	15	n/a	n/a		
BCDL	10.0	Code	FBC2020/TPI2014	Matrix-AS		Wind(LL)	0.03	22-23	>999	240	Weight: 349 lb	FT = 20%

LUMBER
TOP CHORD 2x6 SP No.2 *Except* 1-3,11-14:2x4 SP No.2
BOT CHORD 2x4 SP No.2 *Except* 5-20:2x4 SP No.3
WEBS 2x4 SP No.3 *Except* 18-8:2x6 SP No.2
OTHERS 2x4 SP No.3

BRACING
TOP CHORD Structural wood sheathing directly applied, except end verticals, and 2-0-0 oc purlins (6-0-0 max.): 3-8.
BOT CHORD Rigid ceiling directly applied.
WEBS 1 Row at midpt 8-18, 4-21, 6-21
JOINTS 1 Brace at Jt(s): 26, 27, 29

REACTIONS (lb/size)
15=539/0-5-0, 21=1728/0-3-8, 25=578/0-5-0
Max Horiz 25=439 (LC 6)
Max Uplift 15=286 (LC 11), 21=-879 (LC 7), 25=-263 (LC 10)
Max Grav 15=710 (LC 18), 21=1855 (LC 2), 25=624 (LC 23)

FORCES (lb) - Maximum Compression/Maximum Tension
TOP CHORD 1-2=-736/302, 2-3=-603/304, 3-4=-501/284, 4-5=-261/470, 5-7=-290/475, 7-8=-297/445, 1-25=-607/265, 13-15=-718/480, 8-9=-315/435, 9-10=-365/422, 10-11=-361/341, 11-12=-307/359, 12-13=-351/362, 13-14=0/50
BOT CHORD 24-25=-451/449, 23-24=-484/829, 22-23=-268/271, 21-22=-271/281, 20-21=0/79, 5-21=-328/270, 19-20=-12/0, 18-19=-99/171, 17-18=-100/148, 16-17=-100/148, 15-16=-112/127

WEBS
3-23=-8/149, 4-23=-260/557, 8-18=-171/134, 1-24=-128/523, 16-29=-148/409, 13-29=-147/404, 2-23=-240/218, 2-24=-142/125, 4-22=0/197, 4-21=-1002/593, 6-26=-149/332, 18-26=-145/315, 6-19=-59/220, 19-21=-110/205, 6-21=-805/301, 18-27=-83/142, 27-28=-75/133, 11-28=-75/138, 11-16=-218/101, 7-26=-18/11, 9-27=-13/12, 10-28=-36/106, 17-28=-34/109, 12-29=-14/8

- NOTES**
- Unbalanced roof live loads have been considered for this design.
 - Wind: ASCE 7-16; Vult=140mph (3-second gust) Vasd=108mph; TC DL=4.2psf; BC DL=5.0psf; h=25ft; Cat. II; Exp C; Enclosed; MWFRS (envelope) exterior zone and C-C Exterior(2E) 0-1-12 to 3-9-14, Exterior (2R) 3-9-14 to 12-2-6, Interior (1) 12-2-6 to 22-11-0, Exterior(2R) 22-11-0 to 32-5-5, Exterior(2E) 32-5-5 to 36-1-8 zone; end vertical left and right exposed; C-C for members and forces & MWFRS for reactions shown; Lumber DOL=1.60 plate grip DOL=1.60
 - Truss designed for wind loads in the plane of the truss only. For studs exposed to wind (normal to the face), see Standard Industry Gable End Details as applicable, or consult qualified building designer as per ANSI/TPI 1.
 - Building Designer / Project engineer responsible for verifying applied roof live load shown covers rain loading requirements specific to the use of this truss component.
 - Provide adequate drainage to prevent water ponding.
 - All plates are 2x4 MT20 unless otherwise indicated.
 - Truss to be fully sheathed from one face or securely braced against lateral movement (i.e. diagonal web).
 - Gable studs spaced at 2-0-0 oc.
 - This truss has been designed for a 10.0 psf bottom chord live load nonconcurrent with any other live loads.

- * This truss has been designed for a live load of 20.0psf on the bottom chord in all areas where a rectangle 3-06-00 tall by 2-00-00 wide will fit between the bottom chord and any other members, with BC DL = 10.0psf.
- Bearing at joint(s) 25, 21 considers parallel to grain value using ANSI/TPI 1 angle to grain formula. Building designer should verify capacity of bearing surface.
- Provide mechanical connection (by others) of truss to bearing plate capable of withstanding 263 lb uplift at joint 25, 879 lb uplift at joint 21 and 286 lb uplift at joint 15.
- This truss design requires that a minimum of 7/16" structural wood sheathing be applied directly to the top chord and 1/2" gypsum sheetrock be applied directly to the bottom chord.
- Graphical purlin representation does not depict the size or the orientation of the purlin along the top and/or bottom chord.

LOAD CASE(S) Standard

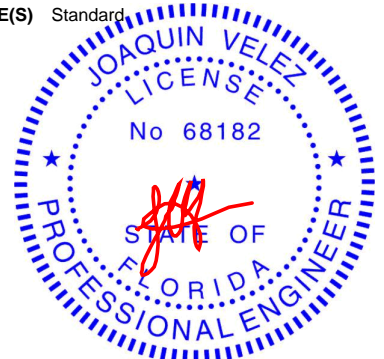

Joaquin Velez PE No.68182
MiTek USA, Inc. FL Cert 6634
6904 Parke East Blvd. Tampa FL 33610
Date:

April 7, 2022

WARNING - Verify design parameters and READ NOTES ON THIS AND INCLUDED MITEK REFERENCE PAGE MII-7473 rev. 5/19/2020 BEFORE USE.

Design valid for use only with MiTek® connectors. This design is based only upon parameters shown, and is for an individual building component, not a truss system. Before use, the building designer must verify the applicability of design parameters and properly incorporate this design into the overall building design. Bracing indicated is to prevent buckling of individual truss web and/or chord members only. Additional temporary and permanent bracing is always required for stability and to prevent collapse with possible personal injury and property damage. For general guidance regarding the fabrication, storage, delivery, erection and bracing of trusses and truss systems, see **ANSI/TPI1 Quality Criteria, DSB-89 and BCSI Building Component Safety Information** available from Truss Plate Institute, 2670 Crain Highway, Suite 203 Waldorf, MD 20601



6904 Parke East Blvd.
Tampa, FL 33610

Job 3039076	Truss A05	Truss Type Piggyback Base	Qty 3	Ply 1	Job Reference (optional) T27365402
----------------	--------------	------------------------------	----------	----------	---------------------------------------

Builders FirstSource (Groveland, FL), Groveland, FL - 34736,

Run: 8.53 S Dec 6 2021 Print: 8.530 S Dec 6 2021 MiTek Industries, Inc. Wed Apr 06 15:09:53
ID:0gGNd9W7LMd920bvz0FbLrzTS7q-RfC?PsB70Hq3NSgPqnL8w3uLTxBGKWrCDoi7J4zJC7f

Page: 1

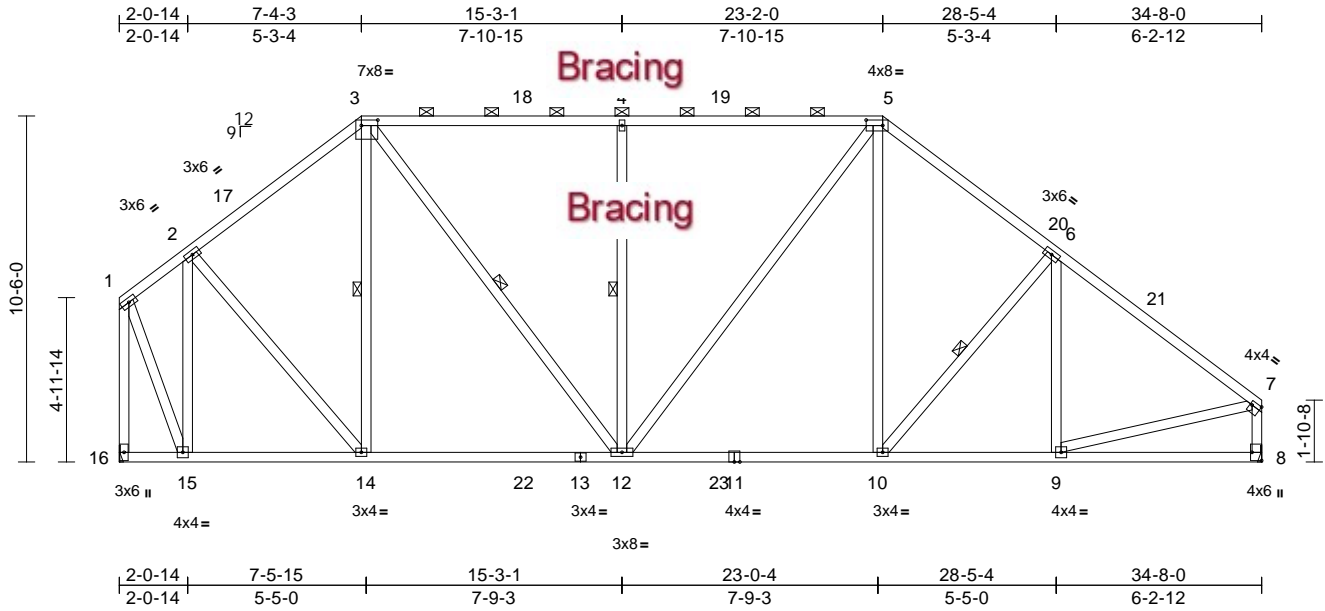

Scale = 1:69.9

Plate Offsets (X, Y): [3:0-6-0,0-2-0], [5:0-6-0,0-2-0], [7:Edge,0-1-8], [8:Edge,0-3-8]

Loading	(psf)	Spacing	2-0-0	CSI	DEFL	in	(loc)	l/defl	L/d	PLATES	GRIP	
TCLL (roof)	20.0	Plate Grip DOL	1.25	TC	0.79	Vert(LL)	-0.14	10-12	>999	360	MT20	244/190
TCDL	10.0	Lumber DOL	1.25	BC	0.75	Vert(CT)	-0.25	10-12	>999	240		
BCLL	0.0*	Rep Stress Incr	YES	WB	0.97	Horz(CT)	0.04	8	n/a	n/a		
BCDL	10.0	Code	FBC2020/TPI2014	Matrix-AS		Wind(LL)	0.07	10-12	>999	240	Weight: 258 lb	FT = 20%

LUMBER
TOP CHORD 2x4 SP No.2
BOT CHORD 2x4 SP No.2
WEBS 2x4 SP No.3 *Except* 12-3,12-5:2x4 SP No.2

BRACING
TOP CHORD Structural wood sheathing directly applied, except end verticals, and 2-0-0 oc purlins (4-2-14 max.): 3-5.
BOT CHORD Rigid ceiling directly applied.
WEBS 1 Row at midpt 3-14, 3-12, 4-12, 6-10

REACTIONS (lb/size) 8=1375/ Mechanical, 16=1375/ Mechanical
Max Horiz 16=458 (LC 6)
Max Uplift 8=596 (LC 11), 16=566 (LC 10)
Max Grav 8=1524 (LC 2), 16=1542 (LC 2)

FORCES (lb) - Maximum Compression/Maximum Tension
TOP CHORD 1-2=-598/353, 2-3=-1210/609, 3-4=-1348/725, 4-5=-1348/725, 5-6=-1566/758, 6-7=-1677/662, 7-8=-1505/586, 7-8=-1414/620
BOT CHORD 15-16=-368/409, 14-15=-427/658, 12-14=-479/906, 10-12=-365/1191, 9-10=-423/1271, 8-9=-106/120
WEBS 2-15=-1032/493, 2-14=-336/675, 3-14=-295/320, 3-12=-437/754, 4-12=-533/469, 5-12=-336/331, 5-10=-166/534, 6-10=-334/303, 6-9=-176/150, 1-15=-472/1216, 7-9=-329/1192

NOTES
1) Unbalanced roof live loads have been considered for this design.

- 2) Wind: ASCE 7-16; Vult=140mph (3-second gust) Vasd=108mph; TC DL=4.2psf; BCDL=5.0psf; h=25ft; Cat. II; Exp C; Enclosed; MWFRS (envelope) interior zone and C-C Exterior(2E) 4-1-12 to 7-7-6, Exterior(2R) 7-7-6 to 16-3-0, Interior (1) 16-3-0 to 22-3-3, Exterior (2R) 22-3-3 to 32-0-13, Interior (1) 32-0-13 to 35-0-10, Exterior(2E) 35-0-10 to 38-6-4 zone; end vertical left and right exposed; C-C for members and forces & MWFRS for reactions shown; Lumber DOL=1.60 plate grip DOL=1.60
- 3) Building Designer / Project engineer responsible for verifying applied roof live load shown covers rain loading requirements specific to the use of this truss component.
- 4) Provide adequate drainage to prevent water ponding.
- 5) This truss has been designed for a 10.0 psf bottom chord live load nonconcurrent with any other live loads.
- 6) * This truss has been designed for a live load of 20.0psf on the bottom chord in all areas where a rectangle 3-06-00 tall by 2-00-00 wide will fit between the bottom chord and any other members, with BCDL = 10.0psf.
- 7) Refer to girder(s) for truss to truss connections.
- 8) Provide mechanical connection (by others) of truss to bearing plate capable of withstanding 566 lb uplift at joint 16 and 596 lb uplift at joint 8.
- 9) This truss design requires that a minimum of 7/16" structural wood sheathing be applied directly to the top chord and 1/2" gypsum sheetrock be applied directly to the bottom chord.
- 10) Graphical purlin representation does not depict the size or the orientation of the purlin along the top and/or bottom chord.

LOAD CASE(S) Standard

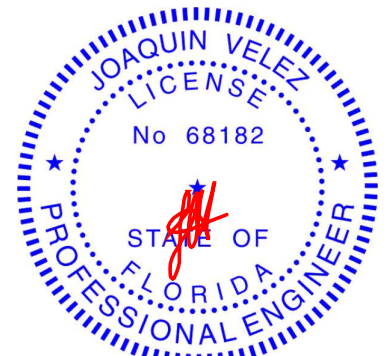

Joaquin Velez PE No.68182
MiTek USA, Inc. FL Cert 6634
6904 Parke East Blvd. Tampa FL 33610
Date:

April 7, 2022

WARNING - Verify design parameters and READ NOTES ON THIS AND INCLUDED MITEK REFERENCE PAGE MII-7473 rev. 5/19/2020 BEFORE USE.

Design valid for use only with MiTek® connectors. This design is based only upon parameters shown, and is for an individual building component, not a truss system. Before use, the building designer must verify the applicability of design parameters and properly incorporate this design into the overall building design. Bracing indicated is to prevent buckling of individual truss web and/or chord members only. Additional temporary and permanent bracing is always required for stability and to prevent collapse with possible personal injury and property damage. For general guidance regarding the fabrication, storage, delivery, erection and bracing of trusses and truss systems, see

ANSI/TPI1 Quality Criteria, DSB-89 and BCSI Building Component

Safety Information available from Truss Plate Institute, 2670 Crain Highway, Suite 203 Waldorf, MD 20601



6904 Parke East Blvd.
Tampa, FL 33610

Job 3039076	Truss A06	Truss Type Piggyback Base Structural Gable	Qty 1	Ply 1	T27365403 Job Reference (optional)
----------------	--------------	---	----------	----------	---------------------------------------

Builders FirstSource (Groveland, FL), Groveland, FL - 34736,

Run: 8.53 S Dec 6 2021 Print: 8.530 S Dec 6 2021 MiTek Industries, Inc. Wed Apr 06 15:09:53
ID:2JLWYXDarlPzOzebOqMGB?zTSAn-RfC?PsB70Hq3NSgPqnL8w3ulTXbGKwKDCoi7J4zJC?f

Page: 1

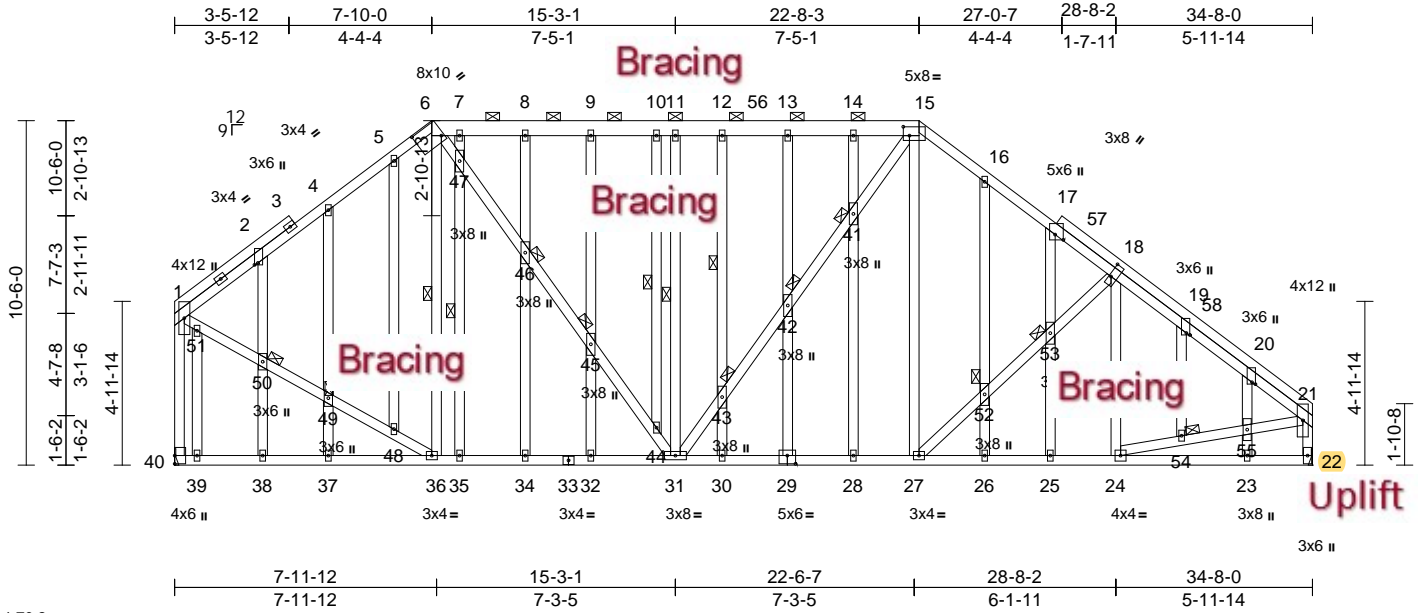

Scale = 1:70.2
Plate Offsets (X, Y): [2:0-0-11,0-1-4], [6:0-9-0,0-6-0], [15:0-2-4,0-3-4], [17:0-1-15,0-3-0], [18:0-5-0,0-0-12], [19:0-0-11,0-1-4], [20:0-0-11,0-1-4], [29:0-3-0,0-3-0]

Loading	(psf)	Spacing	2-0-0	CSI	DEFL	in	(loc)	l/defl	L/d	PLATES	GRIP	
TCLL (roof)	20.0	Plate Grip DOL	1.25	TC	0.66	Vert(LL)	0.15	37-38	>999	240	MT20	244/190
TCDL	10.0	Lumber DOL	1.25	BC	0.53	Vert(CT)	-0.14	37-38	>999	240		
BCLL	0.0*	Rep Stress Incr	YES	WB	0.81	Horz(CT)	0.04	22	n/a	n/a		
BCDL	10.0	Code	FBC2020/TPI2014	Matrix-AS								
											Weight: 442 lb	FT = 20%

LUMBER
TOP CHORD 2x4 SP No.2 *Except* 6-15:2x6 SP No.2
BOT CHORD 2x4 SP No.2
WEBS 2x4 SP No.3
OTHERS 2x4 SP No.3

BRACING
TOP CHORD Structural wood sheathing directly applied, except end verticals, and 2-0-0 oc purlins (6-0-0 max.): 6-15.
BOT CHORD Rigid ceiling directly applied.
WEBS 1 Row at midpt 6-36, 11-31, 12-43, 10-44, 35-47

JOINTS
1 Brace at Jt(s): 41, 42, 43, 45, 46, 49, 50, 52, 53, 54

REACTIONS (lb/size) 22=1377/ Mechanical, 40=1377/ Mechanical
Max Horiz 40=483 (LC 8)
Max Uplift 22=601 (LC 11), 40=570 (LC 30)

FORCES (lb) - Maximum Compression/Maximum Tension
TOP CHORD 1-2=-1150/534, 2-4=-1047/533, 4-5=-1081/668, 5-6=-955/643, 6-7=-1179/723, 7-8=-1185/728, 8-9=-1185/728, 9-10=-1185/728, 10-11=-1185/728, 11-12=-1185/728, 12-13=-1185/728, 13-14=-1185/728, 14-15=-1183/728, 15-16=-1312/799, 16-17=-1330/723, 17-18=-1431/705, 18-19=-1412/699, 19-20=-1543/708, 20-21=-1546/609, 1-40=-1240/512, 21-22=-1301/549

BOT CHORD 39-40=-372/449, 38-39=-372/449, 37-38=-372/449, 36-37=-372/449, 35-36=-487/852, 34-35=-487/852, 32-34=-487/852, 31-32=-487/852, 30-31=-354/1078, 28-30=-355/1078, 27-28=-355/1078, 26-27=-446/1180, 25-26=-446/1180, 24-25=-446/1180, 23-24=-85/93, 22-23=-85/93
WEBS 6-36=-138/148, 6-47=-414/592, 46-47=-439/657, 45-46=-427/636, 44-45=-434/641, 31-44=-406/605, 11-31=-405/275, 31-43=-323/291, 42-43=-322/285, 41-42=-330/303, 15-41=-326/297, 15-27=-306/398, 27-52=-355/312, 52-53=-332/299, 18-53=-344/305, 18-24=-194/117, 1-51=-413/930, 50-51=-404/978, 49-50=-388/947, 48-49=-411/912, 36-48=-408/963, 24-54=-375/1131, 54-55=-368/1106, 21-55=-377/1129, 14-41=-41/63, 28-41=-48/69, 13-42=0/58, 29-42=0/75, 12-43=-35/54, 30-43=-45/59, 10-44=-45/35, 9-45=-8/52, 32-45=-14/61, 8-46=-7/55, 34-46=0/62, 7-47=-97/82, 35-47=-185/113, 5-48=-65/103, 4-49=-208/214, 37-49=-102/147, 2-50=-6/78, 38-50=-16/96, 39-51=-86/118, 16-52=-83/115, 26-52=-55/96, 17-53=0/62, 25-53=-3/55, 19-54=-37/111, 20-55=-119/149, 23-55=-22/109

NOTES
1) Unbalanced roof live loads have been considered for this design.

- 2) Wind: ASCE 7-16; Vult=140mph (3-second gust) Vasd=108mph; TC DL=4.2psf; BCDL=5.0psf; h=25ft; Cat. II; Exp C; Enclosed; MWFRS (envelope) exterior zone and C-C Exterior(2E) 0-1-6 to 3-7-0, Exterior(2R) 3-7-0 to 12-8-3, Interior (1) 12-8-3 to 17-9-5, Exterior (2R) 17-9-5 to 27-7-0, Interior (1) 27-7-0 to 31-1-0, Exterior(2E) 31-1-0 to 34-6-10 zone; end vertical left and right exposed; C-C for members and forces & MWFRS for reactions shown; Lumber DOL=1.60 plate grip DOL=1.60
- 3) Truss designed for wind loads in the plane of the truss only. For studs exposed to wind (normal to the face), see Standard Industry Gable End Details as applicable, or consult qualified building designer as per ANSI/TPI 1.
- 4) Building Designer / Project engineer responsible for verifying applied roof live load shown covers rain loading requirements specific to the use of this truss component.
- 5) Provide adequate drainage to prevent water ponding.
- 6) All plates are 2x4 MT20 unless otherwise indicated.
- 7) Truss to be fully sheathed on one face or securely braced against lateral movement (i.e. diagonal web).
- 8) Gable studs spaced at 2-0-0 oc.

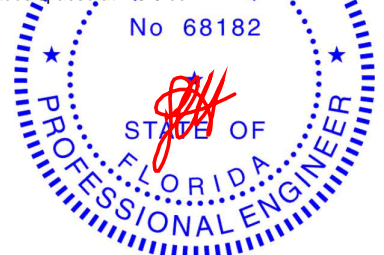

Joaquin Velez PE No.68182
MiTek USA, Inc. FL Cert 6634
6904 Parke East Blvd. Tampa FL 33610
Date: April 7, 2022

Continued on page 2

WARNING - Verify design parameters and READ NOTES ON THIS AND INCLUDED MITEK REFERENCE PAGE MII-7473 rev. 5/19/2020 BEFORE USE.

Design valid for use only with MiTek® connectors. This design is based only upon parameters shown, and is for an individual building component, not a truss system. Before use, the building designer must verify the applicability of design parameters and properly incorporate this design into the overall building design. Bracing indicated is to prevent buckling of individual truss web and/or chord members only. Additional temporary and permanent bracing is always required for stability and to prevent collapse with possible personal injury and property damage. For general guidance regarding the fabrication, storage, delivery, erection and bracing of trusses and truss systems, see **ANSI/TPI1 Quality Criteria, DSB-89 and BCSI Building Component Safety Information** available from Truss Plate Institute, 2670 Crain Highway, Suite 203 Waldorf, MD 20601



Job	Truss	Truss Type	Qty	Ply	Job Reference (optional)
3039076	A06	Piggyback Base Structural Gable	1	1	T27365403

Builders FirstSource (Groveland, FL), Groveland, FL - 34736,

Run: 8.53 S Dec 6 2021 Print: 8.530 S Dec 6 2021 MiTek Industries, Inc. Wed Apr 06 15:09:53
 ID:2JLwyXDarl pzOzebOqMGB?zTSA n-RfC?PsB70Hq3NSgPqnL8w3ulTXbGKW rCDoi7J4zJC?f

Page: 2

- 9) This truss has been designed for a 10.0 psf bottom chord live load nonconcurrent with any other live loads.
- 10) * This truss has been designed for a live load of 20.0psf on the bottom chord in all areas where a rectangle 3-06-00 tall by 2-00-00 wide will fit between the bottom chord and any other members.
- 11) Refer to girder(s) for truss to truss connections.
- 12) Provide mechanical connection (by others) of truss to bearing plate capable of withstanding 570 lb uplift at joint 40 and 601 lb uplift at joint 22.
- 13) This truss design requires that a minimum of 7/16" structural wood sheathing be applied directly to the top chord and 1/2" gypsum sheetrock be applied directly to the bottom chord.
- 14) Graphical purlin representation does not depict the size or the orientation of the purlin along the top and/or bottom chord.

LOAD CASE(S) Standard

WARNING - Verify design parameters and READ NOTES ON THIS AND INCLUDED MITEK REFERENCE PAGE MII-7473 rev. 5/19/2020 BEFORE USE.

Design valid for use only with MiTek® connectors. This design is based only upon parameters shown, and is for an individual building component, not a truss system. Before use, the building designer must verify the applicability of design parameters and properly incorporate this design into the overall building design. Bracing indicated is to prevent buckling of individual truss web and/or chord members only. Additional temporary and permanent bracing is always required for stability and to prevent collapse with possible personal injury and property damage. For general guidance regarding the fabrication, storage, delivery, erection and bracing of trusses and truss systems, see **ANSI/TPI1 Quality Criteria, DSB-89 and BCSI Building Component Safety Information** available from Truss Plate Institute, 2670 Crain Highway, Suite 203 Waldorf, MD 20601



6904 Parke East Blvd.
Tampa, FL 36610

Job 3039076	Truss A07	Truss Type Flat Girder	Qty 1	Ply 2	Job Reference (optional) T27365404
----------------	--------------	---------------------------	----------	----------	---------------------------------------

Builders FirstSource (Groveland, FL), Groveland, FL - 34736,

Run: 8.53 S Dec 6 2021 Print: 8.530 S Dec 6 2021 MiTek Industries, Inc. Wed Apr 06 15:09:55
ID:q8GN7Z?VZjU5JTybuPuzTSEx-RFC?PsB70Hq3NSgPqnL8w3uITxbGKWrCdoi7J4zJC?f

Page: 1

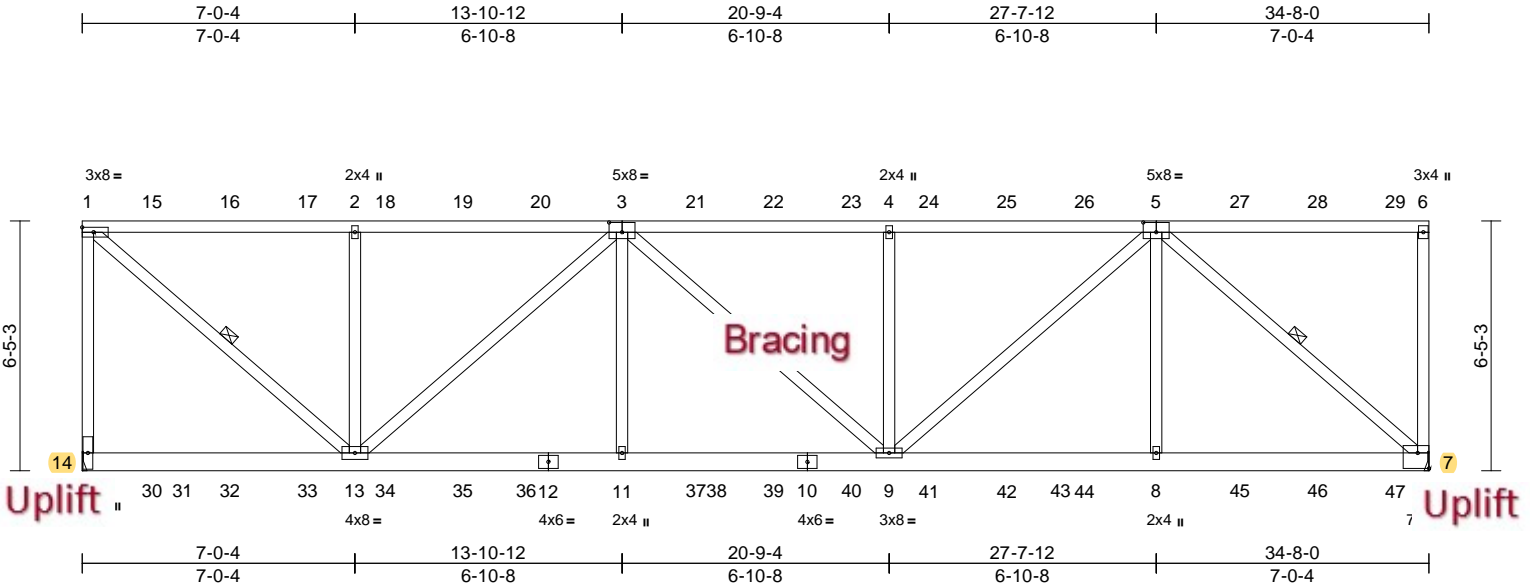

Scale = 1:59.3

Plate Offsets (X, Y): [3:0-4-0,0-3-0], [5:0-4-0,0-3-0], [7:Edge,0-4-12]

Loading	(psf)	Spacing	2-0-0	CSI	DEFL	in	(loc)	l/defl	L/d	PLATES	GRIP	
TCLL (roof)	20.0	Plate Grip DOL	1.25	TC	0.94	Vert(LL)	-0.08	9-11	>999	360	MT20	244/190
TCDL	10.0	Lumber DOL	1.25	BC	0.37	Vert(CT)	-0.16	9-11	>999	240		
BCLL	0.0*	Rep Stress Incr	NO	WB	0.62	Horz(CT)	-0.06	7	n/a	n/a		
BCDL	10.0	Code	FBC2020/TPI2014	Matrix-MS		Wind(LL)	0.25	9-11	>999	240	Weight: 496 lb	FT = 20%

LUMBER
TOP CHORD 2x4 SP No.2
BOT CHORD 2x6 SP No.2
WEBS 2x4 SP No.3

BRACING
TOP CHORD Structural wood sheathing directly applied or 5-9-8 oc purlins, except end verticals.
BOT CHORD Rigid ceiling directly applied or 7-7-5 oc bracing.
WEBS 1 Row at midpt 5-7, 1-13

REACTIONS (lb/size) 7=2214/ Mechanical, 14=2158/ Mechanical
Max Horiz 14=343 (LC 5)
Max Uplift 7=3113 (LC 5), 14=2980 (LC 4)
Max Grav 7=3028 (LC 15), 14=2922 (LC 16)

FORCES (lb) - Maximum Compression/Maximum Tension
TOP CHORD 1-14=-2712/2893, 1-2=-2875/2940, 2-4=-4188/4273, 4-6=-4188/4273, 6-7=-337/469
BOT CHORD 13-14=-283/283, 11-13=-4426/4270, 9-11=-4426/4270, 8-9=-3001/2897, 7-8=-3001/2897
WEBS 5-7=-3770/3842, 2-13=-776/1105, 1-13=-3820/3724, 3-13=-1843/1877, 3-11=-217/504, 3-9=-54/50, 4-9=-705/996, 5-9=-1850/1776, 5-8=-226/552

- All loads are considered equally applied to all plies, except if noted as front (F) or back (B) face in the LOAD CASE(S) section. Ply to ply connections have been provided to distribute only loads noted as (F) or (B), unless otherwise indicated.
- Wind: ASCE 7-16; Vult=140mph (3-second gust) Vasd=108mph; TC DL=4.2psf; BCDL=5.0psf; h=25ft; Cat. II; Exp C; Enclosed; MWFRS (envelope) exterior zone; end vertical left and right exposed; Lumber DOL=1.60 plate grip DOL=1.60
- Building Designer / Project engineer responsible for verifying applied roof live load shown covers rain loading requirements specific to the use of this truss component.
- Provide adequate drainage to prevent water ponding.
- This truss has been designed for a 10.0 psf bottom chord live load nonconcurrent with any other live loads.
- * This truss has been designed for a live load of 20.0psf on the bottom chord in all areas where a rectangle 3-06-00 tall by 2-00-00 wide will fit between the bottom chord and any other members, with BCDL = 10.0psf.
- Refer to girder(s) for truss to truss connections.
- Provide mechanical connection (by others) of truss to bearing plate capable of withstanding 2980 lb uplift at joint 14 and 3113 lb uplift at joint 7.

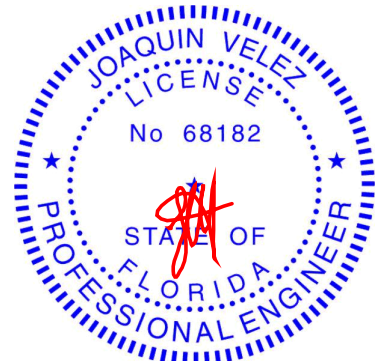

Joaquin Velez PE No.68182
MiTek USA, Inc. FL Cert 6634
6904 Parke East Blvd. Tampa FL 33610
Date:

April 7, 2022

Continued on page 2

WARNING - Verify design parameters and READ NOTES ON THIS AND INCLUDED MITEK REFERENCE PAGE MII-7473 rev. 5/19/2020 BEFORE USE.

Design valid for use only with MiTek® connectors. This design is based only upon parameters shown, and is for an individual building component, not a truss system. Before use, the building designer must verify the applicability of design parameters and properly incorporate this design into the overall building design. Bracing indicated is to prevent buckling of individual truss web and/or chord members only. Additional temporary and permanent bracing is always required for stability and to prevent collapse with possible personal injury and property damage. For general guidance regarding the fabrication, storage, delivery, erection and bracing of trusses and truss systems, see

ANSI/TPI1 Quality Criteria, DSB-89 and BCSI Building Component

Safety Information available from Truss Plate Institute, 2670 Crain Highway, Suite 203 Waldorf, MD 20601



6904 Parke East Blvd.
Tampa, FL 33610

Job 3039076	Truss A07	Truss Type Flat Girder	Qty 1	Ply 2	Job Reference (optional) T27365404
----------------	--------------	---------------------------	----------	----------	---------------------------------------

Builders FirstSource (Groveland, FL), Groveland, FL - 34736,

Run: 8:53 S Dec 6 2021 Print: 8:530 S Dec 6 2021 MiTek Industries, Inc. Wed Apr 06 15:09:55
ID:q8GN7Z?jVZlJjU5JTybuPuzTSEx-RfC?PsB70Hq3NSgPqnL8w3uITXbGKWrCDoi7J4zJC?f

Page: 2

10) Hanger(s) or other connection device(s) shall be provided sufficient to support concentrated load(s) 208 lb down and 209 lb up at 1-9-12, 208 lb down and 209 lb up at 3-9-12, 208 lb down and 209 lb up at 5-9-12, 208 lb down and 209 lb up at 7-9-12, 208 lb down and 209 lb up at 9-9-12, 208 lb down and 209 lb up at 11-9-12, 208 lb down and 209 lb up at 13-9-12, 208 lb down and 209 lb up at 15-9-12, 208 lb down and 209 lb up at 17-9-12, 208 lb down and 209 lb up at 19-9-12, 208 lb down and 209 lb up at 21-9-12, 208 lb down and 209 lb up at 23-9-12, 208 lb down and 209 lb up at 25-9-12, 208 lb down and 209 lb up at 27-9-12, 208 lb down and 209 lb up at 29-9-12, and 208 lb down and 209 lb up at 31-9-12, and 200 lb down and 214 lb up at 33-9-12 on top chord, and 77 lb down and 79 lb up at 1-9-12, 77 lb down and 79 lb up at 3-9-12, 77 lb down and 79 lb up at 5-9-12, 77 lb down and 79 lb up at 7-9-12, 77 lb down and 79 lb up at 9-9-12, 77 lb down and 79 lb up at 11-9-12, 77 lb down and 79 lb up at 13-9-12, 77 lb down and 79 lb up at 15-9-12, 77 lb down and 79 lb up at 17-9-12, 77 lb down and 79 lb up at 19-9-12, 77 lb down and 79 lb up at 21-9-12, 77 lb down and 79 lb up at 23-9-12, 77 lb down and 79 lb up at 25-9-12, 77 lb down and 79 lb up at 27-9-12, 77 lb down and 79 lb up at 29-9-12, and 77 lb down and 79 lb up at 31-9-12, and 78 lb down and 77 lb up at 33-9-12 on bottom chord. The design/selection of such connection device(s) is the responsibility of others.

LOAD CASE(S) Standard

- 1) Dead + Roof Live (balanced): Lumber Increase=1.25, Plate Increase=1.25
Uniform Loads (lb/ft)
Vert: 1-6=-60, 7-14=-20
Concentrated Loads (lb)
Vert: 12=-28 (F), 5=-67 (F), 3=-67 (F), 11=-28 (F), 8=-28 (F), 15=-67 (F), 16=-67 (F), 17=-67 (F), 18=-67 (F), 19=-67 (F), 20=-67 (F), 21=-67 (F), 22=-67 (F), 23=-67 (F), 24=-67 (F), 25=-67 (F), 26=-67 (F), 27=-67 (F), 28=-67 (F), 29=-76 (F), 30=-28 (F), 32=-28 (F), 33=-28 (F), 34=-28 (F), 35=-28 (F), 37=-28 (F), 39=-28 (F), 40=-28 (F), 41=-28 (F), 42=-28 (F), 44=-28 (F), 45=-28 (F), 46=-28 (F), 47=-31 (F)

WARNING - Verify design parameters and READ NOTES ON THIS AND INCLUDED MITEK REFERENCE PAGE MII-7473 rev. 5/19/2020 BEFORE USE.

Design valid for use only with MiTek® connectors. This design is based only upon parameters shown, and is for an individual building component, not a truss system. Before use, the building designer must verify the applicability of design parameters and properly incorporate this design into the overall building design. Bracing indicated is to prevent buckling of individual truss web and/or chord members only. Additional temporary and permanent bracing is always required for stability and to prevent collapse with possible personal injury and property damage. For general guidance regarding the fabrication, storage, delivery, erection and bracing of trusses and truss systems, see **ANSI/TPI1 Quality Criteria, DSB-89 and BCSI Building Component Safety Information** available from Truss Plate Institute, 2670 Crain Highway, Suite 203 Waldorf, MD 20601



6904 Parke East Blvd.
Tampa, FL 36610

Job 3039076	Truss A08	Truss Type Piggyback Base	Qty 4	Ply 1	Job Reference (optional) T27365405
----------------	--------------	------------------------------	----------	----------	---------------------------------------

Builders FirstSource (Groveland, FL), Groveland, FL - 34736,

Run: 8.53 S Dec 6 2021 Print: 8.530 S Dec 6 2021 MiTek Industries, Inc. Wed Apr 06 15:09:55

Page: 1

ID:ORTnH4VQJENKO4BCmWjEvvzTRYP-RfC?PsB70Hq3NSgPqnL8w3uITXbGKWrCDoi7J4zJC?f

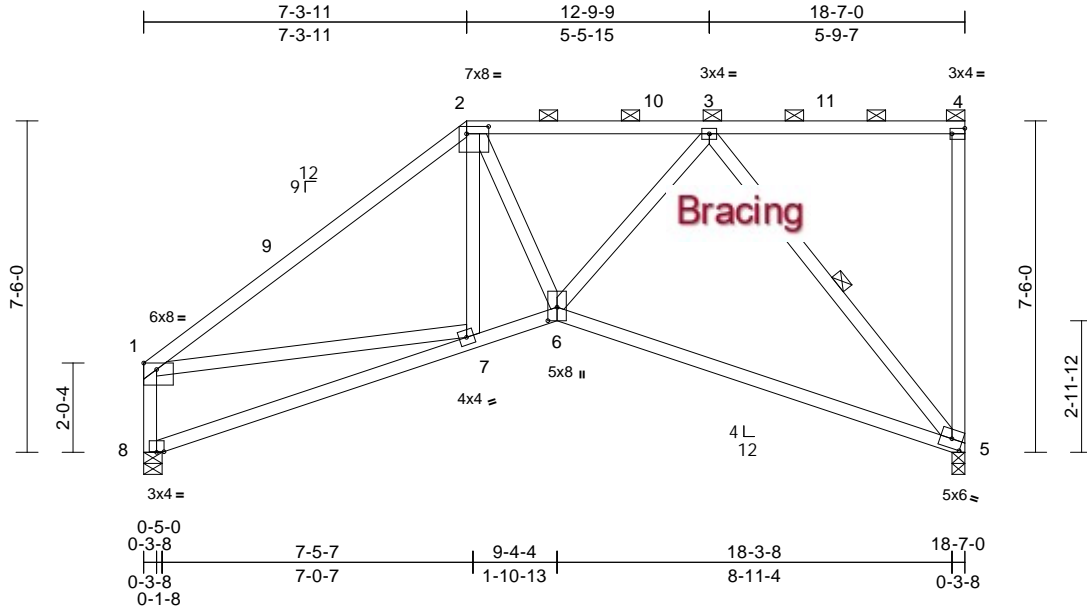

Scale = 1:52.1

Plate Offsets (X, Y): [1:Edge,0-1-12], [2:0-6-0,0-2-0], [4:Edge,0-1-8], [5:0-2-14,0-2-8], [6:0-3-11,0-2-8]

Loading	(psf)	Spacing	2-0-0	CSI	DEFL	in	(loc)	l/defl	L/d	PLATES	GRIP	
TCLL (roof)	20.0	Plate Grip DOL	1.25	TC	0.93	Vert(LL)	-0.22	5-6	>984	360	MT20	244/190
TCDL	10.0	Lumber DOL	1.25	BC	0.74	Vert(CT)	-0.45	5-6	>487	240		
BCLL	0.0*	Rep Stress Incr	YES	WB	0.38	Horz(CT)	-0.05	5	n/a	n/a		
BCDL	10.0	Code	FBC2020/TPI2014	Matrix-AS		Wind(LL)	0.07	5-6	>999	240	Weight: 117 lb	FT = 20%

LUMBER

TOP CHORD 2x4 SP No.2
 BOT CHORD 2x4 SP No.2
 WEBS 2x4 SP No.3

BRACING

TOP CHORD Structural wood sheathing directly applied, except end verticals, and 2-0-0 oc purlins (6-0-0 max.): 2-4.

BOT CHORD Rigid ceiling directly applied.

WEBS 1 Row at midpt 3-5

REACTIONS (lb/size) 5=732/0-3-8, 8=732/0-5-0

Max Horiz 8=415 (LC 7)

Max Uplift 5=-433 (LC 7), 8=-324 (LC 10)

FORCES (lb) - Maximum Compression/Maximum Tension

TOP CHORD 1-2=-1006/435, 2-3=-803/468, 3-4=-196/196, 4-5=-151/137, 1-8=-700/429

BOT CHORD 7-8=-475/425, 6-7=-630/745, 5-6=-529/602

WEBS 2-7=-70/88, 2-6=-104/273, 3-6=-242/482, 3-5=-852/660, 1-7=-165/568

- This truss has been designed for a 10.0 psf bottom chord live load nonconcurrent with any other live loads.
- * This truss has been designed for a live load of 20.0psf on the bottom chord in all areas where a rectangle 3-06-00 tall by 2-00-00 wide will fit between the bottom chord and any other members.
- Bearing at joint(s) 5, 8 considers parallel to grain value using ANSI/TPI 1 angle to grain formula. Building designer should verify capacity of bearing surface.
- Provide mechanical connection (by others) of truss to bearing plate capable of withstanding 433 lb uplift at joint 5 and 324 lb uplift at joint 8.
- This truss design requires that a minimum of 7/16" structural wood sheathing be applied directly to the top chord and 1/2" gypsum sheetrock be applied directly to the bottom chord.
- Graphical purlin representation does not depict the size or the orientation of the purlin along the top and/or bottom chord.

LOAD CASE(S) Standard

NOTES

- Unbalanced roof live loads have been considered for this design.
- Wind: ASCE 7-16; Vult=140mph (3-second gust) Vasd=108mph; TCCL=4.2psf; BCDL=5.0psf; h=25ft; Cat. II; Exp C; Enclosed; MWFRS (envelope) interior zone and C-C Exterior(2E) 0-2-4 to 3-2-4, Exterior(2R) 3-2-4 to 11-7-1, Interior (1) 11-7-1 to 15-5-12, Exterior (2E) 15-5-12 to 18-5-12 zone; end vertical left and right exposed; C-C for members and forces & MWFRS for reactions shown; Lumber DOL=1.60 plate grip DOL=1.60
- Building Designer / Project engineer responsible for verifying applied roof live load shown covers rain loading requirements specific to the use of this truss component.
- Provide adequate drainage to prevent water ponding.

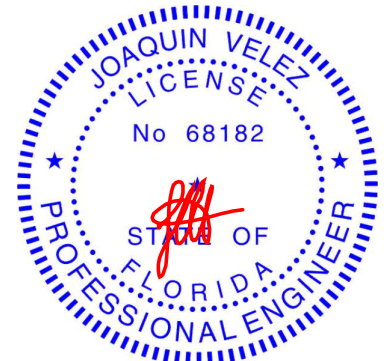

Joaquin Velez PE No.68182
 MiTek USA, Inc. FL Cert 6634
 6904 Parke East Blvd. Tampa FL 33610
 Date:

April 7, 2022

WARNING - Verify design parameters and READ NOTES ON THIS AND INCLUDED MITEK REFERENCE PAGE MII-7473 rev. 5/19/2020 BEFORE USE.

Design valid for use only with MiTek® connectors. This design is based only upon parameters shown, and is for an individual building component, not a truss system. Before use, the building designer must verify the applicability of design parameters and properly incorporate this design into the overall building design. Bracing indicated is to prevent buckling of individual truss web and/or chord members only. Additional temporary and permanent bracing is always required for stability and to prevent collapse with possible personal injury and property damage. For general guidance regarding the fabrication, storage, delivery, erection and bracing of trusses and truss systems, see ANSITPI1 Quality Criteria, DSB-89 and BCSI Building Component Safety Information available from Truss Plate Institute, 2670 Crain Highway, Suite 203 Waldorf, MD 20601



6904 Parke East Blvd.
 Tampa, FL 33610

Job 3039076	Truss B01	Truss Type Attic Structural Gable	Qty 1	Ply 1	Job Reference (optional) T27365406
----------------	--------------	--------------------------------------	----------	----------	---------------------------------------

Builders FirstSource (Groveland, FL), Groveland, FL - 34736,

Run: 8.53 S Dec 6 2021 Print: 8.530 S Dec 6 2021 MiTek Industries, Inc. Wed Apr 06 15:09:56

Page: 1

ID:KofLTx1cbpL1Ra1bmyAG2mzTSrd-RfC?PsB70Hq3NSgPqnL8w3ulTXbGkWrCDoi7J4zJC?7

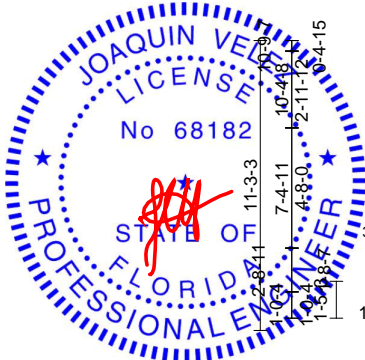

Joaquin Velez PE No.68182
MiTek USA, Inc. FL Cert 6634
6904 Parke East Blvd. Tampa FL 33610
Date:

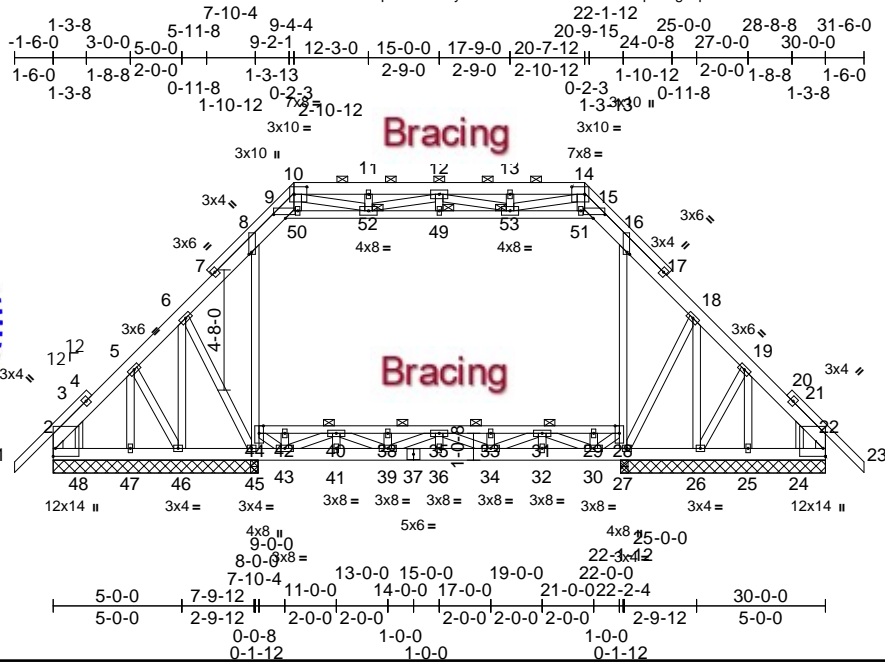

Scale = 1:89.5

Plate Offsets (X, Y): [2:Edge,0-1-1], [8:0-1-0,0-1-4], [9:0-5-8,0-1-12], [10:0-6-0,0-3-8], [14:0-6-0,0-3-8], [15:0-5-8,0-1-12], [16:0-1-0,0-1-4], [22:Edge,0-1-1]

Loading	(psf)	Spacing	2-0-0	CSI	DEFL	in	(loc)	l/defl	L/d	PLATES	GRIP	
TCLL (roof)	20.0	Plate Grip DOL	1.25	TC	0.19	Vert(LL)	-0.09	36	>999	360	MT20	244/190
TCDL	10.0	Lumber DOL	1.25	BC	0.63	Vert(CT)	-0.17	36	>999	240		
BCLL	0.0*	Rep Stress Incr	YES	WB	0.40	Horz(CT)	0.02	22	n/a	n/a		
BCDL	10.0	Code	FBC2020/TPI2014	Matrix-MS		Wind(LL)	0.01	35	>999	240	Weight: 350 lb	FT = 20%

LUMBER	TOP CHORD	BOT CHORD	WEBS	BRACING	TOP CHORD	BOT CHORD	WEBS	REACTIONS	FORCES									
TOP CHORD	2x4 SP No.2 *Except* 10-14,2-10,14-22:2x6 SP M 26	2x6 SP M 26 *Except* 44-28:2x4 SP No.2	2x4 SP No.3	OTHERS	2x4 SP No.3	WEDGE	Left: 2x4 SP No.3 Right: 2x4 SP No.3	TOP CHORD	1-2=0/48, 2-3=-538/460, 3-5=-517/451, 5-6=-595/498, 6-8=-620/520, 8-9=-725/433, 9-10=-674/396, 10-11=-1093/673, 11-12=-1093/673, 12-13=-1093/647, 13-14=-1093/647, 14-15=-674/394, 15-16=-725/417, 16-18=-620/444, 18-19=-595/415, 19-21=-517/354, 21-22=-538/362, 22-23=0/1897, 2-48=-372/434, 47-48=-343/389, 46-47=-343/389, 45-46=-337/406, 43-45=-339/392, 41-43=0/1897, 39-41=0/1897, 36-39=0/2994, 34-36=0/2994, 32-34=0/1898, 30-32=0/1898, 27-30=-337/391, 26-27=-282/387, 25-26=-250/374, 24-25=-250/374, 22-24=-282/424, 42-44=-372/0, 40-42=-372/0, 38-40=-2425/0, 35-38=-2425/0, 33-35=-2425/0, 31-33=-2425/0, 29-31=-372/0, 28-29=-372/0	BOT CHORD	44-45=-726/32, 8-44=-416/192, 27-28=-692/2, 16-28=-367/149, 9-50=-323/378, 50-52=-244/315, 49-52=-488/830, 49-53=-488/830, 51-53=-244/276, 15-51=-323/332, 12-49=-132/109, 10-50=-197/241, 14-51=-174/241, 11-52=-76/96, 13-53=-76/97, 12-53=-236/236, 14-53=-508/784, 12-52=-236/249, 10-52=-490/784, 35-36=0/175, 29-30=-244/0, 33-34=-210/0, 31-32=0/108, 42-43=-244/0, 40-41=0/108, 38-39=-210/0, 34-35=-515/0, 31-34=0/745, 30-31=-1531/0, 28-30=0/553, 35-39=-515/0, 39-40=0/745, 40-43=-1531/0, 43-44=0/553, 6-46=-192/128, 5-47=-200/110, 3-48=-176/126, 18-26=-192/111, 19-25=-200/94, 21-24=-176/125, 19-26=-84/108, 5-46=-54/88, 18-27=-126/148, 6-45=-95/127	WEBS	Structural wood sheathing directly applied or 6-0-0 oc purlins, except 2-0-0 oc purlins (6-0-0 max.): 10-14.	Rigid ceiling directly applied or 10-0-0 oc bracing. Except: 6-0-0 oc bracing: 28-44	1 Brace at Jt(s): 49, 52, 53	(lb/size)	2=680/7-11-8, 22=680/7-11-8, 24=108/7-11-8, 25=317/7-11-8, 26=6/7-11-8, 27=833/7-11-8, 45=833/7-11-8, 46=6/7-11-8, 47=317/7-11-8, 48=108/7-11-8 Max Horiz 2=-419 (LC 8) Max Uplift 2=-310 (LC 6), 22=-369 (LC 7), 24=-170 (LC 21), 25=-45 (LC 7), 26=-337 (LC 16), 46=-337 (LC 16), 47=-57 (LC 7), 48=-143 (LC 21) Max Grav 2=680 (LC 1), 22=680 (LC 1), 24=169 (LC 9), 25=338 (LC 2), 26=6 (LC 1), 27=1572 (LC 19), 45=1608 (LC 18), 46=6 (LC 1), 47=338 (LC 2), 48=117 (LC 9)	(lb) - Maximum Compression/Maximum Tension

NOTES

April 7, 2022

Continued on page 2

WARNING - Verify design parameters and READ NOTES ON THIS AND INCLUDED MITEK REFERENCE PAGE MII-7473 rev. 5/19/2020 BEFORE USE.

Design valid for use only with MiTek® connectors. This design is based only upon parameters shown, and is for an individual building component, not a truss system. Before use, the building designer must verify the applicability of design parameters and properly incorporate this design into the overall building design. Bracing indicated is to prevent buckling of individual truss web and/or chord members only. Additional temporary and permanent bracing is always required for stability and to prevent collapse with possible personal injury and property damage. For general guidance regarding the fabrication, storage, delivery, erection and bracing of trusses and truss systems, see ANSITPI1 Quality Criteria, DSB-89 and BCSI Building Component Safety Information available from Truss Plate Institute, 2670 Crain Highway, Suite 203 Waldorf, MD 20601



6904 Parke East Blvd.
Tampa, FL 33610

Job 3039076	Truss B01	Truss Type Attic Structural Gable	Qty 1	Ply 1	T27365406 Job Reference (optional)
----------------	--------------	--------------------------------------	----------	----------	---------------------------------------

Builders FirstSource (Groveland, FL), Groveland, FL - 34736,

Run: 8:53 S Dec 6 2021 Print: 8:530 S Dec 6 2021 MiTek Industries, Inc. Wed Apr 06 15:09:56
ID:KofLTx1cbpL1Ra1bmyAG2mzTSrd-RfC?PsB70Hq3NSgPqnL8w3ulTXbGKWrCDoi7J4zJC?i

Page: 2

- 8) This truss has been designed for a 10.0 psf bottom chord live load nonconcurrent with any other live loads.
- 9) * This truss has been designed for a live load of 20.0psf on the bottom chord in all areas where a rectangle 3-06-00 tall by 2-00-00 wide will fit between the bottom chord and any other members.
- 10) Ceiling dead load (5.0 psf) on member(s). 8-9, 15-16, 9-50, 50-52, 49-52, 49-53, 51-53, 15-51; Wall dead load (5.0psf) on member(s).8-44, 16-28
- 11) Bottom chord live load (40.0 psf) and additional bottom chord dead load (10.0 psf) applied only to room. 42-44, 40-42, 38-40, 35-38, 33-35, 31-33, 29-31, 28-29
- 12) Provide mechanical connection (by others) of truss to bearing plate capable of withstanding 310 lb uplift at joint 2, 369 lb uplift at joint 22, 337 lb uplift at joint 46, 57 lb uplift at joint 47, 143 lb uplift at joint 48, 337 lb uplift at joint 26, 45 lb uplift at joint 25 and 170 lb uplift at joint 24.
- 13) Graphical purlin representation does not depict the size or the orientation of the purlin along the top and/or bottom chord.
- 14) Attic room checked for L/360 deflection.

LOAD CASE(S) Standard

WARNING - Verify design parameters and READ NOTES ON THIS AND INCLUDED MITEK REFERENCE PAGE MII-7473 rev. 5/19/2020 BEFORE USE.

Design valid for use only with MiTek® connectors. This design is based only upon parameters shown, and is for an individual building component, not a truss system. Before use, the building designer must verify the applicability of design parameters and properly incorporate this design into the overall building design. Bracing indicated is to prevent buckling of individual truss web and/or chord members only. Additional temporary and permanent bracing is always required for stability and to prevent collapse with possible personal injury and property damage. For general guidance regarding the fabrication, storage, delivery, erection and bracing of trusses and truss systems, see **ANSI/TPI1 Quality Criteria, DSB-89 and BCSI Building Component Safety Information** available from Truss Plate Institute, 2670 Crain Highway, Suite 203 Waldorf, MD 20601



6904 Parke East Blvd.
Tampa, FL 36610

Job 3039076	Truss B02	Truss Type Attic	Qty 1	Ply 1	Job Reference (optional) T27365407
----------------	--------------	---------------------	----------	----------	---------------------------------------

Builders FirstSource (Groveland, FL), Groveland, FL - 34736,

Run: 8.53 S Feb 23 2022 Print: 8.530 S Feb 23 2022 MiTek Industries, Inc. Thu Apr 07 12:16:18

Page: 1

ID:c8UmK07?2qvO9?FLKrUdqtzTnl5-68lAnTPB2ls8?1h2mWwaNwaseAuSDS?ZXmo8LzfTJ0j

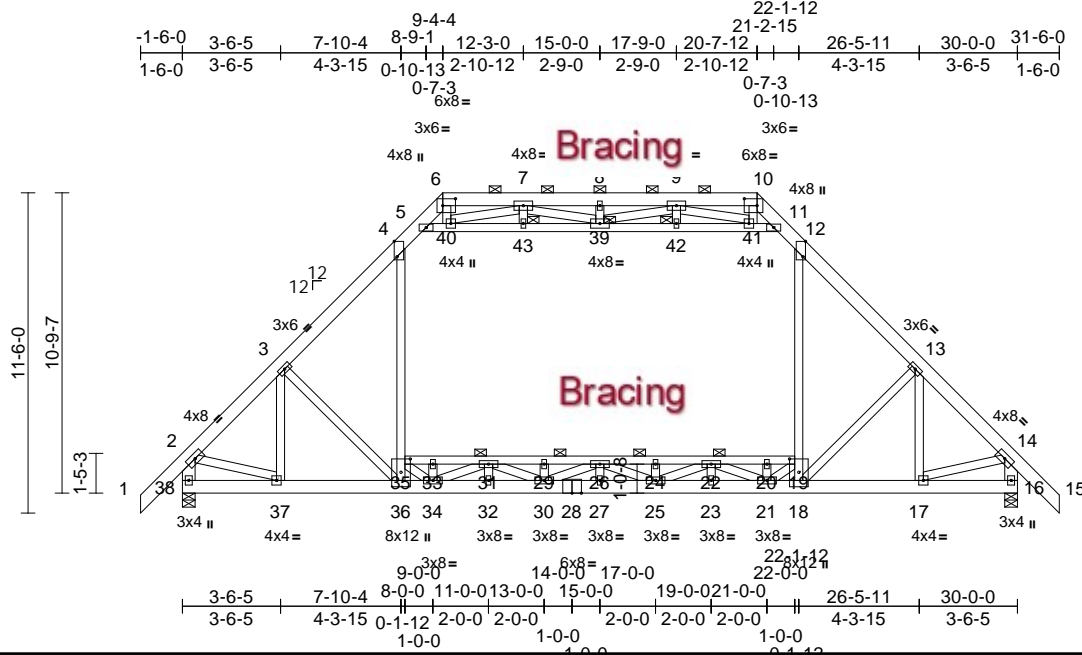

Scale = 1:82.8
Plate Offsets (X, Y): [4:0-6-10,Edge], [6:0-5-8,0-3-0], [10:0-5-8,0-3-0], [12:0-6-10,Edge], [18:0-5-12,0-4-0], [36:0-5-12,0-4-0]

Loading	(psf)	Spacing	2-0-0	CSI	DEFL	in	(loc)	l/defl	L/d	PLATES	GRIP
TCLL (roof)	20.0	Plate Grip DOL	1.25	TC	0.16	Vert(LL)	-0.15	27	>999	360	MT20 244/190
TCDL	10.0	Lumber DOL	1.25	BC	0.72	Vert(CT)	-0.28	27	>999	240	
BCLL	0.0*	Rep Stress Incr	YES	WB	0.80	Horz(CT)	0.04	16	n/a	n/a	
BCDL	10.0	Code	FBC2020/TPI2014	Matrix-MS		Wind(LL)	0.16	36-37	>999	240	Weight: 321 lb FT = 20%

LUMBER
TOP CHORD 2x6 SP M 26
BOT CHORD 2x6 SP M 26 *Except* 35-19:2x4 SP No.2
WEBS 2x4 SP No.3 *Except* 38-2,16-14:2x6 SP No.2, 5-11:2x4 SP No.2

BRACING
TOP CHORD Structural wood sheathing directly applied or 6-0-0 oc purlins, except end verticals, and 2-0-0 oc purlins (6-0-0 max.): 6-10.
BOT CHORD Rigid ceiling directly applied or 10-0-0 oc bracing. Except:
6-0-0 oc bracing: 19-35

JOINTS
1 Brace at Jt(s): 39, 42, 43

REACTIONS (lb/size) 16=1720/0-5-8, 38=1720/0-5-8
Max Horiz 38=486 (LC 8)
Max Uplift 16=278 (LC 11), 38=278 (LC 10)
Max Grav 16=1984 (LC 2), 38=1984 (LC 2)

FORCES (lb) - Max. Comp./Max. Ten. - All forces 250 (lb) or less except when shown.
TOP CHORD 2-3=-1914/242, 3-4=-2162/235, 4-5=-1365/367, 5-6=-218/710, 6-7=-214/769, 7-8=-1151/1128, 8-9=-1151/1128, 9-10=-213/769, 10-11=-218/710, 11-12=-1365/367, 12-13=-2162/235, 13-14=-1914/244, 2-38=-1879/335, 14-16=-1879/335
BOT CHORD 37-38=-338/446, 36-37=-344/1540, 34-36=-164/1458, 32-34=0/3269, 30-32=0/3269, 28-30=0/4286, 27-28=0/4286, 25-27=0/4286, 23-25=0/3147, 21-23=0/3147, 18-21=-24/1388, 17-18=-20/1307, 33-35=-825/305, 31-33=-825/305, 29-31=-2599/0, 26-29=-2599/0, 24-26=-2599/0, 22-24=-2599/0, 20-22=-840/323, 19-20=-840/323

WEBS
35-36=-284/701, 4-35=0/1101, 18-19=-292/714, 12-19=0/1101, 5-40=-2057/540, 40-43=-1166/0, 39-43=-1167/0, 39-42=-1168/0, 41-42=-1167/0, 11-41=-2058/541, 3-36=-315/466, 3-37=-596/141, 2-37=-99/1239, 13-18=-321/469, 13-17=-604/151, 14-17=-92/1239, 6-40=-319/48, 10-41=-319/48, 25-26=-481/38, 22-25=-34/870, 21-22=-1428/0, 19-21=-313/1095, 26-30=-508/70, 30-31=-2/843, 31-34=-1428/0, 34-35=-294/1079, 7-39=-511/249, 9-39=-510/249, 9-41=-1239/600, 7-40=-1239/600

NOTES
1) Unbalanced roof live loads have been considered for this design.
2) Wind: ASCE 7-16; Vult=140mph (3-second gust) Vasd=108mph; TCDL=4.2psf; BCDL=5.0psf; h=25ft; Cat. II; Exp C; Enclosed: MWFRS (envelope) exterior zone and C-C Exterior(2E) -1-6-0 to 1-6-0, Interior (1) 1-6-0 to 5-1-5, Exterior(2R) 5-1-5 to 13-7-3, Interior (1) 13-7-3 to 16-4-13, Exterior(2R) 16-4-13 to 24-10-11, Interior (1) 24-10-11 to 28-6-0, Exterior(2E) 28-6-0 to 31-6-0 zone; end vertical left and right exposed; C-C for members and forces & MWFRS for reactions shown; Lumber DOL=1.60 plate grip DOL=1.60
3) Building Designer / Project engineer responsible for verifying applied roof live load shown covers rain loading requirements specific to the use of this truss component.
4) Provide adequate drainage to prevent water ponding.
5) All plates are 2x4 MT20 unless otherwise indicated.
6) This truss has been designed for a 10.0 psf bottom chord live load nonconcurrent with any other live loads.

7) * This truss has been designed for a live load of 20.0psf on the bottom chord in all areas where a rectangle 3-06-00 tall by 2-00-00 wide will fit between the bottom chord and any other members.
8) Ceiling dead load (5.0 psf) on member(s). 4-5, 11-12, 5-40, 40-43, 39-43, 39-42, 41-42, 11-41; Wall dead load (5.0psf) on member(s).4-35, 12-19
9) Bottom chord live load (40.0 psf) and additional bottom chord dead load (10.0 psf) applied only to room. 33-35, 31-33, 29-31, 26-29, 24-26, 22-24, 20-22, 19-20
10) Provide mechanical connection (by others) of truss to bearing plate capable of withstanding 278 lb uplift at joint 38 and 278 lb uplift at joint 16.
11) Graphical purlin representation does not depict the size or the orientation of the purlin along the top and/or bottom chord.
12) Attic room checked for L/360 deflection.
LOAD CASE(S) Standard

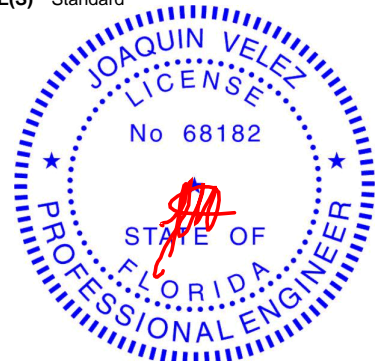

Joaquin Velez PE No.68182
MiTek USA, Inc. FL Cert 6634
6904 Parke East Blvd. Tampa FL 33610
Date: April 7, 2022

Job 3039076	Truss B02A	Truss Type Attic	Qty 3	Ply 1	Job Reference (optional) T27365408
----------------	---------------	---------------------	----------	----------	---------------------------------------

Builders FirstSource (Groveland, FL), Groveland, FL - 34736,

Run: 8.53 S Feb 23 2022 Print: 8.530 S Feb 23 2022 MiTek Industries, Inc. Thu Apr 07 12:19:37

Page: 1

ID:rUnkiT?9NLYLNn_ctGiU6ezTnep-kpP9zCrGiWAcwdZh1D1iJODrBUTpMj8Y_HvVzT7La

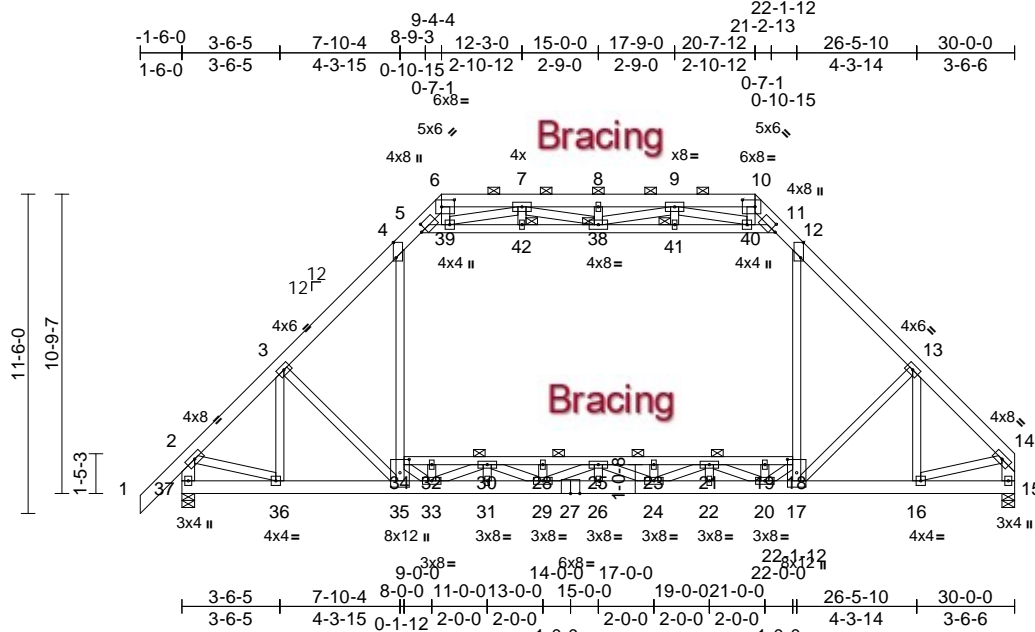

Scale = 1:83

Plate Offsets (X, Y): [4:0-6-10,Edge], [5:0-2-1,0-2-12], [6:0-5-8,0-3-0], [10:0-5-8,0-3-0], [11:0-2-1,0-2-12], [12:0-6-10,Edge], [13:0-0-0,0-0-0], [17:0-5-12,0-4-0], [35:0-5-12,0-4-0]

Loading	(psf)	Spacing	2-0-0	CSI	DEFL	in	(loc)	l/defl	L/d	PLATES	GRIP
TCLL (roof)	20.0	Plate Grip DOL	1.25	TC	0.16	Vert(LL)	-0.15	26	>999	360	MT20 244/190
TCDL	10.0	Lumber DOL	1.25	BC	0.72	Vert(CT)	-0.28	26	>999	240	
BCLL	0.0*	Rep Stress Incr	YES	WB	0.81	Horz(CT)	0.04	15	n/a	n/a	
BCDL	10.0	Code	FBC2020/TPI2014	Matrix-MS		Wind(LL)	0.16	35-36	>999	240	Weight: 316 lb FT = 20%

LUMBER
TOP CHORD 2x6 SP M 26
BOT CHORD 2x6 SP M 26 *Except* 34-18:2x4 SP No.2
WEBS 2x4 SP No.3 *Except* 5-11:2x4 SP No.2, 37-2,15-14:2x6 SP No.2

BRACING
TOP CHORD Structural wood sheathing directly applied or 6-0-0 oc purlins, except end verticals, and 2-0-0 oc purlins (6-0-0 max.): 6-10.
BOT CHORD Rigid ceiling directly applied or 10-0-0 oc bracing. Except:
6-0-0 oc bracing: 18-34

JOINTS
1 Brace at Jt(s): 38, 41, 42

REACTIONS
(lb/size) 15=1614/0-5-8, 37=1723/0-5-8
Max Horiz 37=464 (LC 7)
Max Uplift 15=201 (LC 11), 37=278 (LC 30)
Max Grav 15=1895 (LC 2), 37=1987 (LC 2)

FORCES
(lb) - Max. Comp./Max. Ten. - All forces 250 (lb) or less except when shown.
TOP CHORD 2-3=-1915/242, 3-4=-2166/238, 4-5=-1364/369, 5-6=-225/701, 6-7=-215/775, 7-8=-1154/1128, 8-9=-1154/1128, 9-10=-208/761, 10-11=-232/697, 11-12=-1364/368, 12-13=-2172/242, 13-14=-1924/244, 2-37=-1881/336, 14-15=-1791/256
BOT CHORD 36-37=-364/403, 35-36=-372/1508, 33-35=-191/1426, 31-33=0/3238, 29-31=0/3238, 27-29=0/4287, 26-27=0/4287, 24-26=0/4287, 22-24=0/3150, 20-22=0/3150, 17-20=-52/1393, 16-17=-121/1326, 32-34=-821/304, 30-32=-821/304, 28-30=-2598/0, 25-28=-2598/0, 23-25=-2600/0, 21-23=-2600/0, 19-21=-850/323, 18-19=-850/323

WEBS
34-35=-292/712, 4-34=0/1102, 17-18=-297/717, 12-18=0/1107, 5-39=-2066/544, 39-42=-1168/0, 38-42=-1170/0, 38-41=-1164/0, 40-41=-1163/0, 11-40=-2052/536, 3-35=-316/465, 3-36=601/143, 2-36=-100/1239, 13-17=-333/482, 13-16=-600/158, 14-16=-117/1243, 6-39=-290/63, 10-40=-289/62, 24-25=-482/36, 21-24=-37/865, 20-21=-1427/0, 18-20=-313/1106, 25-29=-510/68, 29-30=-7/849, 30-33=-1429/0, 33-34=-293/1074, 7-38=-511/251, 7-39=-1239/599, 9-38=-510/248, 9-40=-1240/598

NOTES
1) Unbalanced roof live loads have been considered for this design.
2) Wind: ASCE 7-16; Vult=140mph (3-second gust) Vasd=108mph; TC DL=4.2psf; BCDL=5.0psf; h=25ft; Cat. II; Exp C; Enclosed: MWFRS (envelope) exterior zone and C-C Exterior(2E) -1-6-0 to 1-6-0, Interior (1) 1-6-0 to 5-1-5, Exterior(2R) 5-1-5 to 13-7-3, Interior (1) 13-7-3 to 16-4-13, Exterior(2R) 16-4-13 to 24-10-11, Interior (1) 24-10-11 to 26-9-4, Exterior(2E) 26-9-4 to 29-9-4 zone; end vertical left and right exposed; C-C for members and forces & MWFRS for reactions shown; Lumber DOL=1.60 plate grip DOL=1.60
3) Building Designer / Project engineer responsible for verifying applied roof live load shown covers rain loading requirements specific to the use of this truss component.
4) Provide adequate drainage to prevent water ponding.
5) All plates are 2x4 MT20 unless otherwise indicated.
6) This truss has been designed for a 10.0 psf bottom chord live load nonconcurrent with any other live loads.

- 7) * This truss has been designed for a live load of 20.0psf on the bottom chord in all areas where a rectangle 3-06-00 tall by 2-00-00 wide will fit between the bottom chord and any other members.
- 8) Ceiling dead load (5.0 psf) on member(s). 4-5, 11-12, 5-39, 39-42, 38-42, 38-41, 40-41, 11-40; Wall dead load (5.0psf) on member(s).4-34, 12-18
- 9) Bottom chord live load (40.0 psf) and additional bottom chord dead load (10.0 psf) applied only to room. 32-34, 30-32, 28-30, 25-28, 23-25, 21-23, 19-21, 18-19
- 10) Provide mechanical connection (by others) of truss to bearing plate capable of withstanding 278 lb uplift at joint 37 and 201 lb uplift at joint 15.
- 11) Graphical purlin representation does not depict the size or the orientation of the purlin along the top and/or bottom chord.
- 12) Attic room checked for L/360 deflection.

LOAD CASE(S) Standard

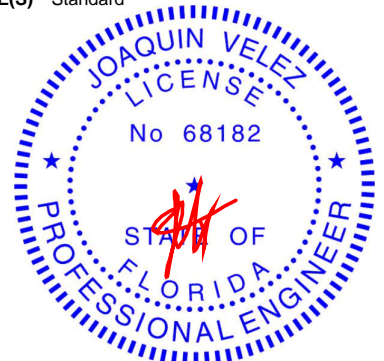

Joaquin Velez PE No.68182
MiTek USA, Inc. FL Cert 6634
6904 Parke East Blvd. Tampa FL 33610
Date: April 7, 2022

Job 3039076	Truss B02B	Truss Type Attic	Qty 5	Ply 1	Job Reference (optional) T27365409
----------------	---------------	---------------------	----------	----------	---------------------------------------

Builders FirstSource (Groveland, FL), Groveland, FL - 34736,

Run: 8.53 S Dec 6 2021 Print: 8.530 S Dec 6 2021 MiTek Industries, Inc. Wed Apr 06 15:09:59

Page: 1

ID:eY7JmnoRiPmZ_dosJBuxzTnbE-RfC?PsB70Hq3NSgPqnL8w3uITXbGKWRcDoi7J4zJC?f

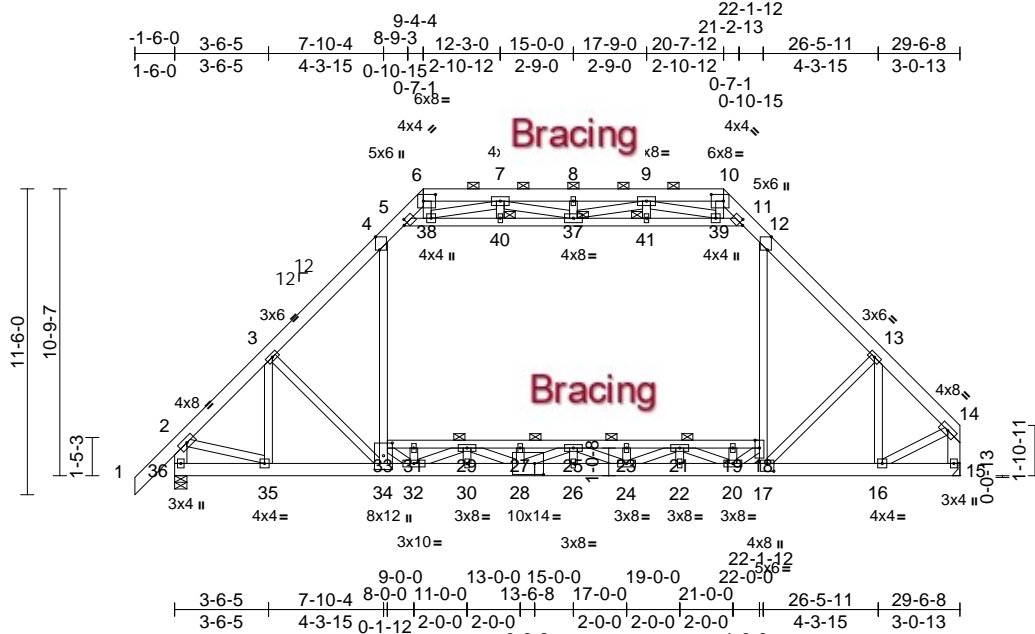

Scale = 1:86.7

Plate Offsets (X, Y): [4:0-5-14,Edge], [5:0-1-13,0-2-0], [6:0-5-8,0-3-0], [10:0-5-8,0-3-0], [11:0-1-13,0-2-0], [12:0-5-14,Edge], [17:0-3-0,0-3-8], [28:0-4-0,0-5-0], [34:0-5-12,0-4-0]

Loading	(psf)	Spacing	2-0-0	CSI	DEFL	in (loc)	l/defl	L/d	PLATES	GRIP		
TCLL (roof)	20.0	Plate Grip DOL	1.25	TC	0.18	Vert(LL)	-0.15	25-27	>999	360	MT20	244/190
TCDL	10.0	Lumber DOL	1.25	BC	0.73	Vert(CT)	-0.28	25-27	>999	240		
BCLL	0.0*	Rep Stress Incr	YES	WB	0.85	Horz(CT)	0.04	15	n/a	n/a		
BCDL	10.0	Code	FBC2020/TPI2014	Matrix-MS		Wind(LL)	0.17	34-35	>999	240	Weight: 314 lb	FT = 20%

LUMBER
TOP CHORD 2x6 SP M 26
BOT CHORD 2x6 SP M 26 *Except* 33-18:2x4 SP No.2
WEBS 2x4 SP No.3 *Except* 5-11:2x4 SP No.2, 36-2,15-14:2x6 SP No.2

BRACING
TOP CHORD Structural wood sheathing directly applied or 6-0-0 oc purlins, except end verticals, and 2-0-0 oc purlins (6-0-0 max.): 6-10.
BOT CHORD Rigid ceiling directly applied or 10-0-0 oc bracing. Except:
6-0-0 oc bracing: 18-33

JOINTS
1 Brace at Jt(s): 37, 40, 41

REACTIONS (lb/size)
15=1602/ Mechanical, 36=1698/0-5-8
Max Horiz 36=473 (LC 7)
Max Uplift 15=187 (LC 11), 36=276 (LC 10)
Max Grav 15=1893 (LC 2), 36=1957 (LC 2)

FORCES (lb) - Maximum Compression/Maximum Tension
TOP CHORD 1-2=0/73, 2-3=-1895/241, 3-4=-2112/235, 4-5=-1329/367, 5-6=-282/667, 6-7=-199/715, 7-8=-1178/1127, 8-9=-1178/1127, 9-10=-213/798, 10-11=-215/705, 11-12=-1342/368, 12-13=-2082/234, 13-14=-1654/211, 2-36=-1864/335, 14-15=-1780/246
BOT CHORD 35-36=-374/397, 34-35=-381/1497, 32-34=-202/1397, 30-32=0/3267, 26-30=0/4250, 24-26=0/4250, 22-24=0/3047, 20-22=0/3047, 17-20=-64/1328, 16-17=-129/1140, 15-16=-42/103, 31-33=-919/298, 29-31=-919/298, 27-29=-2630/0, 25-27=-2630/0, 23-25=-2571/0, 21-23=-2571/0, 19-21=-751/326, 18-19=-751/326

WEBS
33-34=-277/618, 4-33=0/1086, 17-18=-295/714, 12-18=0/1035, 5-38=-1925/520, 38-40=-1089/3, 37-40=-1090/1, 37-41=-1136/0, 39-41=-1134/0, 11-39=-2047/539, 3-34=-336/468, 3-35=-556/143, 2-35=-100/1241, 13-17=-281/580, 13-16=-814/144, 14-16=-139/1203, 8-37=-113/78, 6-38=-269/78, 10-39=-277/73, 7-40=0/230, 9-41=0/237, 9-37=-507/281, 9-39=-1265/597, 7-37=-511/245, 7-38=-1178/599, 25-26=0/127, 31-32=-231/0, 19-20=-243/0, 21-22=0/58, 23-24=-218/0, 27-28=-216/0, 29-30=0/60, 24-25=-520/33, 21-24=-35/903, 20-21=-1461/0, 18-20=-317/997, 25-28=-478/68, 28-29=-7/803, 29-32=-1403/0, 32-33=-286/1182

NOTES
1) Unbalanced roof live loads have been considered for this design.
2) Wind: ASCE 7-16; Vult=140mph (3-second gust) Vasd=108mph; TC DL=4.2psf; BCDL=5.0psf; h=25ft; Cat. II; Exp C; Enclosed; MWFRS (envelope) exterior zone and C-C Exterior(2E) -1-6-0 to 1-6-0, Interior (1) 1-6-0 to 5-1-5, Exterior(2R) 5-1-5 to 13-7-3, Interior (1) 13-7-3 to 16-4-13, Exterior(2R) 16-4-13 to 24-10-11, Interior (1) 24-10-11 to 26-3-12, Exterior(2E) 26-3-12 to 29-3-12 zone; end vertical left and right exposed; C-C for members and forces & MWFRS for reactions shown; Lumber DOL=1.60 plate grip DOL=1.60
3) Building Designer / Project engineer responsible for verifying applied roof live load shown covers rain loading requirements specific to the use of this truss component.
4) Provide adequate drainage to prevent water ponding.
5) All plates are 2x4 MT20 unless otherwise indicated.
6) This truss has been designed for a 10.0 psf bottom chord live load nonconcurrent with any other live loads.

- * This truss has been designed for a live load of 20.0psf on the bottom chord in all areas where a rectangle 3-06-00 tall by 2-00-00 wide will fit between the bottom chord and any other members.
- Ceiling dead load (5.0 psf) on member(s). 4-5, 11-12, 5-38, 38-40, 37-40, 37-41, 39-41, 11-39; Wall dead load (5.0psf) on member(s).4-33, 12-18
- Bottom chord live load (40.0 psf) and additional bottom chord dead load (10.0 psf) applied only to room. 31-33, 29-31, 27-29, 25-27, 23-25, 21-23, 19-21, 18-19
- Refer to girder(s) for truss to truss connections.
- Provide mechanical connection (by others) of truss to bearing plate capable of withstanding 276 lb uplift at joint 36 and 187 lb uplift at joint 15.
- Graphical purlin representation does not depict the size or the orientation of the purlin along the top and/or bottom chord.
- Attic room checked for L/360 deflection.

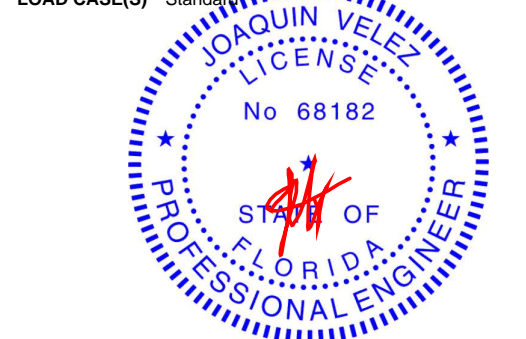

Joaquin Velez PE No.68182
MiTek USA, Inc. FL Cert 6634
6904 Parke East Blvd. Tampa FL 33610
Date: April 7, 2022

Job 3039076	Truss B02C	Truss Type Attic	Qty 6	Ply 1	Job Reference (optional) T27365410
----------------	---------------	---------------------	----------	----------	---------------------------------------

Builders FirstSource (Groveland, FL), Groveland, FL - 34736,

Run: 8.53 S Dec 6 2021 Print: 8.530 S Dec 6 2021 MiTek Industries, Inc. Wed Apr 06 15:09:59

Page: 1

ID: g0sZTnDFqTgJOWyEAL6kLzTnQJ-RfC?PsB70Hg3NSgPqnL8w3uTXbGKWrCDoi7J4zJC?f

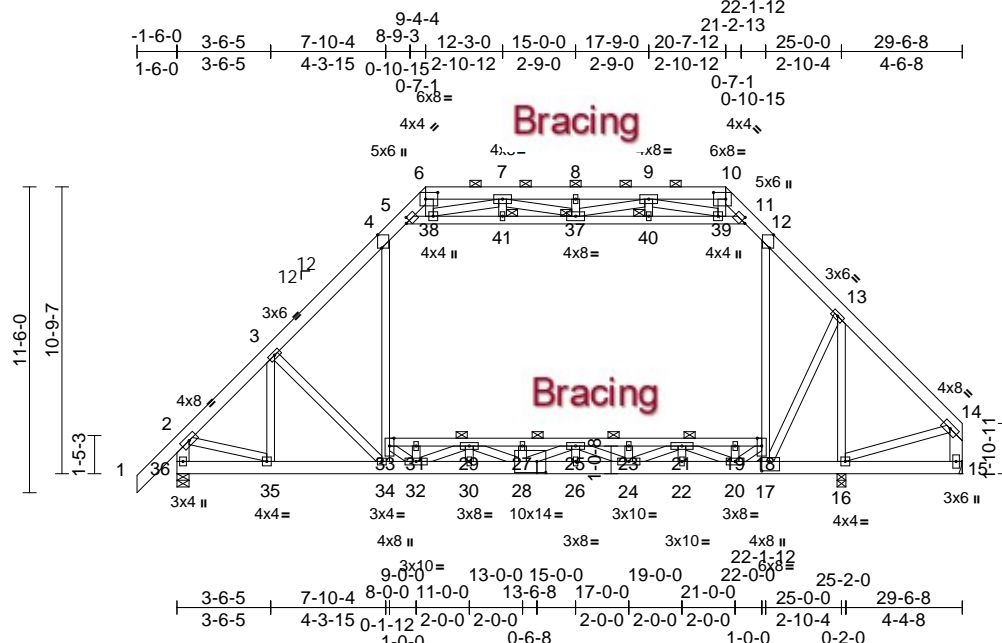

Scale = 1:86.7

Plate Offsets (X, Y): [4:0-5-14,Edge], [5:0-1-13,0-2-0], [6:0-5-8,0-3-0], [10:0-5-8,0-3-0], [11:0-1-13,0-2-0], [12:0-5-14,Edge], [17:0-3-8,0-4-4], [28:0-4-0,0-5-0]

Loading	(psf)	Spacing	2-0-0	CSI	DEFL	in	(loc)	l/defl	L/d	PLATES	GRIP
TCLL (roof)	20.0	Plate Grip DOL	1.25	TC	0.21	Vert(LL)	-0.15	25-27	>999	360	MT20 244/190
TCDL	10.0	Lumber DOL	1.25	BC	0.73	Vert(CT)	-0.28	25-27	>999	240	
BCLL	0.0*	Rep Stress Incr	YES	WB	0.91	Horz(CT)	0.04	15	n/a	n/a	
BCDL	10.0	Code	FBC2020/TPI2014	Matrix-MS		Wind(LL)	0.07	34	>999	240	Weight: 319 lb FT = 20%

LUMBER
TOP CHORD 2x6 SP M 26
BOT CHORD 2x6 SP M 26 *Except* 33-18:2x4 SP No.2
WEBS 2x4 SP No.3 *Except* 5-11:2x4 SP No.2, 36-2,15-14:2x6 SP No.2

BRACING
TOP CHORD Structural wood sheathing directly applied or 6-0-0 oc purlins, except end verticals, and 2-0-0 oc purlins (6-0-0 max.): 6-10.
BOT CHORD Rigid ceiling directly applied or 10-0-0 oc bracing. Except: 6-0-0 oc bracing: 18-33

JOINTS
1 Brace at Jt(s): 37, 40, 41

REACTIONS (lb/size)
15=1508/ Mechanical, 16=110/0-4-0, 36=1682/0-5-8
Max Horiz 36=473 (LC 7)
Max Uplift 15=-544 (LC 10), 16=-554 (LC 6), 36=-355 (LC 10)
Max Grav 15=1901 (LC 18), 16=770 (LC 9), 36=1927 (LC 2)

FORCES (lb) - Maximum Compression/Maximum Tension
TOP CHORD 1-2=0/73, 2-3=-1874/295, 3-4=-2059/330, 4-5=-1305/445, 5-6=-237/480, 6-7=-114/379, 7-8=-1258/1228, 8-9=-1258/1228, 9-10=-67/692, 10-11=-214/644, 11-12=-1320/411, 12-13=-1996/481, 13-14=-1876/573, 2-36=-1845/381, 14-15=-1795/544

BOT CHORD 35-36=-420/429, 34-35=-418/1508, 32-34=-315/1438, 30-32=0/3192, 26-30=0/4153, 24-26=0/4153, 22-24=0/2841, 20-22=0/2841, 17-20=-304/1356, 16-17=-413/1310, 15-16=-43/116, 31-33=-774/0, 29-31=-774/0, 27-29=-2637/0, 25-27=-2637/0, 23-25=-2477/0, 21-23=-2477/0, 19-21=-309/47, 18-19=-309/47
WEBS 33-34=-18/276, 4-33=0/1059, 17-18=-380/853, 12-18=-186/1107, 5-38=-1675/337, 38-41=-1031/86, 37-41=-1032/84, 37-40=-1152/59, 39-40=-1150/61, 11-39=-2003/515, 14-16=-403/1271, 13-17=-32/638, 13-16=-1099/274, 3-34=-202/332, 3-35=-428/9, 2-35=-95/1239, 25-26=0/127, 8-37=-110/84, 6-38=-288/109, 10-39=-303/105, 9-40=0/242, 7-41=-4/223, 7-37=-495/244, 7-38=-1144/450, 9-37=-413/270, 9-39=-1241/515, 31-32=-224/0, 19-20=-255/0, 21-22=0/58, 23-24=-220/0, 27-28=-215/0, 29-30=0/63, 24-25=-539/0, 21-24=0/916, 20-21=-1511/0, 18-20=-20/498, 25-28=-361/0, 28-29=0/710, 29-32=-1356/0, 32-33=0/1047

NOTES
1) Unbalanced roof live loads have been considered for this design.
2) Wind: ASCE 7-16; Vult=140mph (3-second gust) Vasd=108mph; TC DL=4.2psf; BCDL=5.0psf; h=25ft; Cat. II; Exp C; Enclosed; MWFRS (envelope) exterior zone and C-C Exterior(2E) -1-6-0 to 1-6-0, Interior (1) 1-6-0 to 5-1-5, Exterior(2R) 5-1-5 to 13-7-3, Interior (1) 13-7-3 to 16-4-13, Exterior(2R) 16-4-13 to 25-0-0, Interior (1) 25-0-0 to 26-3-12, Exterior(2E) 26-3-12 to 29-3-12 zone; end vertical left and right exposed; C-C for members and forces & MWFRS for reactions shown; Lumber DOL=1.60 plate grip DOL=1.60

- Building Designer / Project engineer responsible for verifying applied roof live load shown covers rain loading requirements specific to the use of this truss component.
- Provide adequate drainage to prevent water ponding.
- All plates are 2x4 MT20 unless otherwise indicated.
- This truss has been designed for a 10.0 psf bottom chord live load nonconcurrent with any other live loads.
- * This truss has been designed for a live load of 20.0psf on the bottom chord in all areas where a rectangle 3-06-00 tall by 2-00-00 wide will fit between the bottom chord and any other members.
- Ceiling dead load (5.0 psf) on member(s). 4-5, 11-12, 5-38, 38-41, 37-41, 37-40, 39-40, 11-39; Wall dead load (5.0psf) on member(s). 4-33, 12-18
- Bottom chord live load (40.0 psf) and additional bottom chord dead load (10.0 psf) applied only to room. 31-33, 29-31, 27-29, 25-27, 23-25, 21-23, 19-21, 18-19
- Refer to girder(s) for truss to girder connections.
- Provide mechanical connection (by others) of truss to bearing plate capable of withstanding 355 lb. uplift at joint 36, 544 lb. uplift at joint 15 and 554 lb. uplift at joint 16.

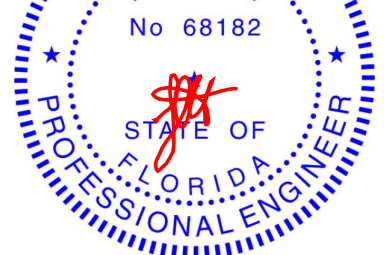

Joaquin Velez PE No.68182
MiTek USA, Inc. FL Cert 6634
6904 Parke East Blvd. Tampa FL 33610
Date: April 7, 2022

Continued on page 2

WARNING - Verify design parameters and READ NOTES ON THIS AND INCLUDED MITEK REFERENCE PAGE MII-7473 rev. 5/19/2020 BEFORE USE.
Design valid for use only with MiTek® connectors. This design is based only upon parameters shown, and is for an individual building component, not a truss system. Before use, the building designer must verify the applicability of design parameters and properly incorporate this design into the overall building design. Bracing indicated is to prevent buckling of individual truss web and/or chord members only. Additional temporary and permanent bracing is always required for stability and to prevent collapse with possible personal injury and property damage. For general guidance regarding the fabrication, storage, delivery, erection and bracing of trusses and truss systems, see **ANSI/TPI1 Quality Criteria, DSB-89 and BCSI Building Component Safety Information** available from Truss Plate Institute, 2670 Crain Highway, Suite 203 Waldorf, MD 20601



Job	Truss	Truss Type	Qty	Ply	T27365410
3039076	B02C	Attic	6	1	Job Reference (optional)

Builders FirstSource (Groveland, FL), Groveland, FL - 34736,

Run: 8.53 S Dec 6 2021 Print: 8.530 S Dec 6 2021 MiTek Industries, Inc. Wed Apr 06 15:09:59
 ID:g0sZTnDFqTTgjOwyEAL6kLzTnQJ-RfC?PsB70Hq3NSgPqnL8w3ulTXbGKWrcDoi7J4zJC?i

Page: 2

12) Graphical purlin representation does not depict the size or the orientation of the purlin along the top and/or bottom chord.

13) Attic room checked for L/360 deflection.

LOAD CASE(S) Standard

WARNING - Verify design parameters and READ NOTES ON THIS AND INCLUDED MITEK REFERENCE PAGE MII-7473 rev. 5/19/2020 BEFORE USE.

Design valid for use only with MiTek® connectors. This design is based only upon parameters shown, and is for an individual building component, not a truss system. Before use, the building designer must verify the applicability of design parameters and properly incorporate this design into the overall building design. Bracing indicated is to prevent buckling of individual truss web and/or chord members only. Additional temporary and permanent bracing is always required for stability and to prevent collapse with possible personal injury and property damage. For general guidance regarding the fabrication, storage, delivery, erection and bracing of trusses and truss systems, see **ANSI/TPI1 Quality Criteria, DSB-89 and BCSI Building Component Safety Information** available from Truss Plate Institute, 2670 Crain Highway, Suite 203 Waldorf, MD 20601



6904 Parke East Blvd.
Tampa, FL 36610

Job 3039076	Truss B02D	Truss Type Attic Girder	Qty 1	Ply 1	Job Reference (optional) T27365411
----------------	---------------	----------------------------	----------	----------	---------------------------------------

Builders FirstSource (Groveland, FL), Groveland, FL - 34736,

Run: 8.53 S Dec 6 2021 Print: 8.530 S Dec 6 2021 MiTek Industries, Inc. Wed Apr 06 15:10:00

Page: 1

ID:2qE8pdWt3RJGxyvfVb8H7zTnGv-RfC?PsB70Hq3NSgPqnL8w3uITXbGKwRcDoi7J4zJC7f

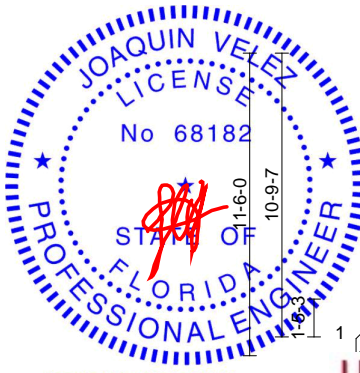

Joaquin Velez PE No.68182
MiTek USA, Inc. FL Cert 6634
6904 Parke East Blvd. Tampa FL 33610
Date:

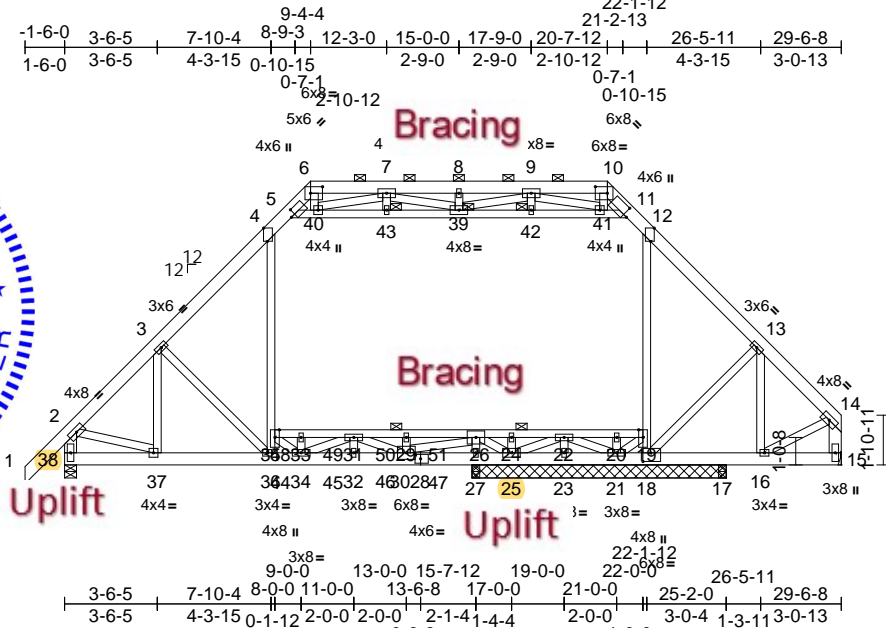

Scale = 1:87.6

Plate Offsets (X, Y): [4:0-6-2,Edge], [5:0-2-1,0-2-12], [6:0-5-8,0-3-0], [10:0-5-8,0-3-0], [11:0-1-13,0-4-0], [12:0-6-2,Edge], [18:0-3-8,0-4-0], [28:0-2-8,0-2-0]

Loading	(psf)	Spacing	2-0-0	CSI	DEFL	in (loc)	l/defl	L/d	PLATES	GRIP		
TCLL (roof)	20.0	Plate Grip DOL	1.25	TC	0.18	Vert(LL)	-0.06	34-36	>999	360	MT20	244/190
TCDL	10.0	Lumber DOL	1.25	BC	0.57	Vert(CT)	-0.13	36	>999	240		
BCLL	0.0*	Rep Stress Incr	NO	WB	0.77	Horz(CT)	0.01	15	n/a	n/a		
BCDL	10.0	Code	FBC2020/TPI2014	Matrix-MS		Wind(LL)	0.09	36-37	>999	240		Weight: 314 lb FT = 20%

LUMBER	TOP CHORD	BOT CHORD	WEBS	BRACING	TOP CHORD	BOT CHORD	JOINTS	REACTIONS	FORCES	TOP CHORD	NOTES
2x6 SP M 26	2x6 SP M 26 *Except* 35-19:2x4 SP No.2	37-38=-444/419, 36-37=-661/1507, 34-36=-588/1417, 32-34=-446/1700, 30-32=-446/1700, 27-30=-1189/399, 25-27=-891/337, 23-25=-327/629, 21-23=-327/629, 18-21=-573/1361, 17-18=-411/1132, 16-17=-411/1132, 15-16=-42/82, 33-35=-540/79, 31-33=-540/79, 29-31=-367/742, 26-29=-382/695, 24-26=-292/1080, 22-24=-292/1080, 20-22=-48/187, 19-20=-48/187	2x4 SP No.3 *Except* 38-2,15-14:2x6 SP No.2, 5-11:2x4 SP No.2	Structural wood sheathing directly applied or 6-0-0 oc purlins, except end verticals, and 2-0-0 oc purlins (6-0-0 max.): 6-10.	Rigid ceiling directly applied or 10-0-0 oc bracing, Except: 6-0-0 oc bracing: 27-30,25-27. 10-0-0 oc bracing: 19-35	1 Brace at Jt(s): 39, 42, 43	15=1871/ Mechanical, 17=156/0-3-8, 18=-972/9-8-0, 21=-43/9-8-0, 23=368/9-8-0, 25=-1230/9-8-0, 27=2345/0-3-8, 38=2037/0-5-8	(lb) - Maximum Compression/Maximum Tension	1-2=0/73, 2-3=-2001/605, 3-4=-2067/700, 4-5=-1297/621, 5-6=-80/541, 6-7=-58/430, 7-8=-1061/1258, 8-9=-1061/1258, 9-10=-254/666, 10-11=-196/643, 11-12=-1320/591, 12-13=-2013/814, 13-14=-1659/603, 2-38=-1995/667, 14-15=-1794/630	1) Unbalanced roof live loads have been considered for this design. 2) Wind: ASCE 7-16; Vult=140mph (3-second gust) Vasd=108mph; TC DL=4.2psf; BCDL=5.0psf; h=25ft; Cat. II; Exp C; Enclosed; MWFRS (envelope) exterior zone; end vertical left and right exposed; Lumber DOL=1.60 plate grip DOL=1.60	
3-6-5	7-10-4	8-0-0	11-0-0	13-6-8	17-0-0	21-0-0	25-2-0	29-6-8			
3-6-5	4-3-15	0-1-12	2-0-0	0-6-8	2-1-4	1-4-4	2-0-0	1-0-0			
9-4-4	8-9-3	12-3-0	15-0-0	17-9-0	20-7-12	22-1-12	26-5-11	29-6-8			
1-6-0	3-6-5	7-10-4	8-9-3	12-3-0	15-0-0	17-9-0	20-7-12	22-1-12	26-5-11	29-6-8	
1-6-0	3-6-5	4-3-15	0-1-12	2-0-0	2-9-0	2-9-0	2-10-12	4-3-15	3-0-13		
9-4-4	8-9-3	12-3-0	15-0-0	17-9-0	20-7-12	22-1-12	26-5-11	29-6-8			
1-6-0	3-6-5	7-10-4	8-9-3	12-3-0	15-0-0	17-9-0	20-7-12	22-1-12	26-5-11	29-6-8	
1-6-0	3-6-5	4-3-15	0-1-12	2-0-0	2-9-0	2-9-0	2-10-12	4-3-15	3-0-13		

April 7, 2022

Continued on page 2

WARNING - Verify design parameters and READ NOTES ON THIS AND INCLUDED MITEK REFERENCE PAGE MII-7473 rev. 5/19/2020 BEFORE USE.

Design valid for use only with MiTek® connectors. This design is based only upon parameters shown, and is for an individual building component, not a truss system. Before use, the building designer must verify the applicability of design parameters and properly incorporate this design into the overall building design. Bracing indicated is to prevent buckling of individual truss web and/or chord members only. Additional temporary and permanent bracing is always required for stability and to prevent collapse with possible personal injury and property damage. For general guidance regarding the fabrication, storage, delivery, erection and bracing of trusses and truss systems, see **ANSI/TPI1 Quality Criteria, DSB-89 and BCSI Building Component Safety Information** available from Truss Plate Institute, 2670 Crain Highway, Suite 203 Waldorf, MD 20601

6904 Parke East Blvd.
Tampa, FL 33610

Job	Truss	Truss Type	Qty	Ply	T27365411
3039076	B02D	Attic Girder	1	1	Job Reference (optional)

Builders FirstSource (Groveland, FL), Groveland, FL - 34736,

Run: 8.53 S Dec 6 2021 Print: 8.530 S Dec 6 2021 MiTek Industries, Inc. Wed Apr 06 15:10:00
ID:2qE8pdWt3RJGxyfVb8H7IzTnGv-RfC?PsB70Hq3NSgPqnL8w3uITXbGKWrCDoi7J4zJC?f

Page: 2

- 11) Provide mechanical connection (by others) of truss to bearing plate capable of withstanding 650 lb uplift at joint 38, 1266 lb uplift at joint 18, 636 lb uplift at joint 15, 66 lb uplift at joint 21, 36 lb uplift at joint 23, 1284 lb uplift at joint 25, 573 lb uplift at joint 27 and 38 lb uplift at joint 17.
- 12) Graphical purlin representation does not depict the size or the orientation of the purlin along the top and/or bottom chord.
- 13) This truss has large uplift reaction(s) from gravity load case(s). Proper connection is required to secure truss against upward movement at the bearings. Building designer must provide for uplift reactions indicated.
- 14) Hanger(s) or other connection device(s) shall be provided sufficient to support concentrated load(s) 496 lb down and 100 lb up at 7-10-4, 188 lb down and 92 lb up at 8-2-12, 188 lb down and 92 lb up at 10-2-12, and 188 lb down and 92 lb up at 12-2-12, and 188 lb down and 92 lb up at 14-2-12 on bottom chord. The design/selection of such connection device(s) is the responsibility of others.
- 15) Attic room checked for L/360 deflection.
- 16) In the LOAD CASE(S) section, loads applied to the face of the truss are noted as front (F) or back (B).

LOAD CASE(S) Standard

- 1) Dead + Roof Live (balanced): Lumber Increase=1.25, Plate Increase=1.25
Uniform Loads (lb/ft)
Vert: 1-2=-60, 2-4=-60, 4-5=-70, 5-6=-60, 6-10=-60, 10-11=-60, 11-12=-70, 12-14=-60, 15-38=-20, 19-35=-40, 5-40=-10, 40-43=-10, 39-43=-10, 39-42=-10, 41-42=-10, 11-41=-10
Drag: 4-35=-10, 12-19=-10
Concentrated Loads (lb)
Vert: 36=-481 (F), 44=-188 (F), 45=-188 (F), 46=-188 (F), 47=-188 (F)

WARNING - Verify design parameters and READ NOTES ON THIS AND INCLUDED MITEK REFERENCE PAGE MII-7473 rev. 5/19/2020 BEFORE USE.

Design valid for use only with MiTek® connectors. This design is based only upon parameters shown, and is for an individual building component, not a truss system. Before use, the building designer must verify the applicability of design parameters and properly incorporate this design into the overall building design. Bracing indicated is to prevent buckling of individual truss web and/or chord members only. Additional temporary and permanent bracing is always required for stability and to prevent collapse with possible personal injury and property damage. For general guidance regarding the fabrication, storage, delivery, erection and bracing of trusses and truss systems, see **ANSI/TPI1 Quality Criteria, DSB-89 and BCSI Building Component Safety Information** available from Truss Plate Institute, 2670 Crain Highway, Suite 203 Waldorf, MD 20601



6904 Parke East Blvd.
Tampa, FL 36610

Job 3039076	Truss B04	Truss Type Piggyback Base	Qty 7	Ply 1	Job Reference (optional)	T27365412
----------------	--------------	------------------------------	----------	----------	--------------------------	-----------

Builders FirstSource (Groveland, FL), Groveland, FL - 34736,

Run: 8:53 S Dec 6 2021 Print: 8:530 S Dec 6 2021 MiTek Industries, Inc. Wed Apr 06 15:10:01
ID:LupwYyQGgEzKxCzIrl0ozTT96-RfC?PsB70Hq3NSgPqnL8w3uITXbGKwRcDoi7J4zJC?F

Page: 1

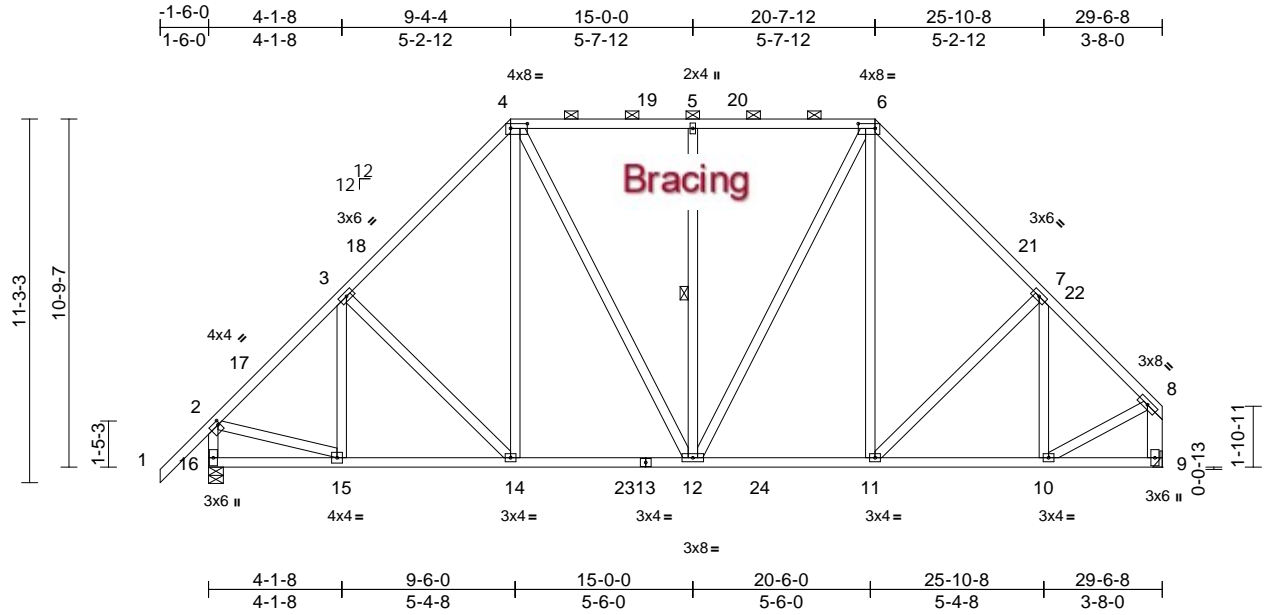

Scale = 1:71.4

Plate Offsets (X, Y): [2:0-0-12,0-1-8], [4:0-6-4,0-1-12], [6:0-6-4,0-1-12]

Loading	(psf)	Spacing	2-0-0	CSI	DEFL	in (loc)	l/defl	L/d	PLATES	GRIP		
TCLL (roof)	20.0	Plate Grip DOL	1.25	TC	0.51	Vert(LL)	-0.05	12-14	>999	360	MT20	244/190
TCDL	10.0	Lumber DOL	1.25	BC	0.39	Vert(CT)	-0.09	12-14	>999	240		
BCLL	0.0*	Rep Stress Incr	YES	WB	0.84	Horz(CT)	0.03	9	n/a	n/a		
BCDL	10.0	Code	FBC2020/TPI2014	Matrix-MS		Wind(LL)	0.04	12-14	>999	240	Weight: 235 lb	FT = 20%

LUMBER
TOP CHORD 2x4 SP No.2
BOT CHORD 2x4 SP No.2
WEBS 2x4 SP No.3 *Except* 9-8:2x6 SP No.2

BRACING
TOP CHORD Structural wood sheathing directly applied or 5-1-8 oc purlins, except end verticals, and 2-0-0 oc purlins (5-9-6 max.): 4-6.
BOT CHORD Rigid ceiling directly applied or 8-0-10 oc bracing.
WEBS 1 Row at midpt 5-12

REACTIONS (lb/size) 9=1164/ Mechanical, 16=1268/0-5-8
Max Horiz 16=481 (LC 7)
Max Uplift 9=-469 (LC 11), 16=-547 (LC 10)
Max Grav 9=1289 (LC 2), 16=1374 (LC 2)

FORCES (lb) - Maximum Compression/Maximum Tension
TOP CHORD 1-2=0/70, 2-3=-1302/536, 3-4=-1232/650, 4-5=-936/635, 5-6=-936/635, 6-7=-1201/644, 7-8=-1153/492, 2-16=-1313/614, 8-9=-1239/500
BOT CHORD 15-16=-450/419, 14-15=-542/1033, 12-14=-424/844, 11-12=-278/779, 10-11=-269/785, 9-10=-37/38
WEBS 4-14=-180/420, 4-12=-306/336, 5-12=-385/341, 6-12=-315/380, 6-11=-149/364, 2-15=-238/898, 8-10=-271/859, 7-11=-247/293, 7-10=-266/174, 3-14=-273/337, 3-15=-147/120

- Wind: ASCE 7-16; Vult=140mph (3-second gust) Vasd=108mph; TC DL=4.2psf; BCDL=5.0psf; h=25ft; Cat. II; Exp C; Enclosed; MWFRS (envelope) exterior zone and C-C Exterior(2E) -1-6-0 to 1-6-0, Interior (1) 1-6-0 to 5-1-5, Exterior(2R) 5-1-5 to 13-7-3, Interior (1) 13-7-3 to 16-4-13, Exterior(2R) 16-4-13 to 24-10-11, Interior (1) 24-10-11 to 26-3-12, Exterior(2E) 26-3-12 to 29-3-12 zone; end vertical left and right exposed; C-C for members and forces & MWFRS for reactions shown; Lumber DOL=1.60 plate grip DOL=1.60
 - Building Designer / Project engineer responsible for verifying applied roof live load shown covers rain loading requirements specific to the use of this truss component.
 - Provide adequate drainage to prevent water ponding.
 - This truss has been designed for a 10.0 psf bottom chord live load nonconcurrent with any other live loads.
 - * This truss has been designed for a live load of 20.0psf on the bottom chord in all areas where a rectangle 3-06-00 tall by 2-00-00 wide will fit between the bottom chord and any other members, with BCDL = 10.0psf.
 - Refer to girder(s) for truss to truss connections.
 - Provide mechanical connection (by others) of truss to bearing plate capable of withstanding 547 lb uplift at joint 16 and 469 lb uplift at joint 9.
 - Graphical purlin representation does not depict the size or the orientation of the purlin along the top and/or bottom chord.
 - Attic room checked for L/360 deflection.
- LOAD CASE(S)** Standard

NOTES
1) Unbalanced roof live loads have been considered for this design.

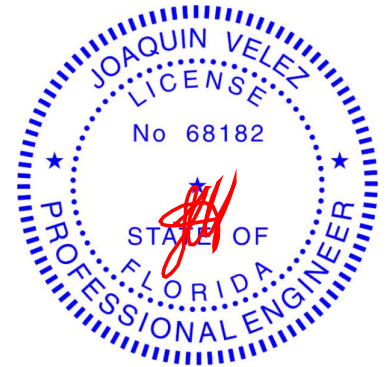

Joaquin Velez PE No.68182
MiTek USA, Inc. FL Cert 6634
6904 Parke East Blvd. Tampa FL 33610
Date:

April 7, 2022

WARNING - Verify design parameters and READ NOTES ON THIS AND INCLUDED MITEK REFERENCE PAGE MII-7473 rev. 5/19/2020 BEFORE USE.

Design valid for use only with MiTek® connectors. This design is based only upon parameters shown, and is for an individual building component, not a truss system. Before use, the building designer must verify the applicability of design parameters and properly incorporate this design into the overall building design. Bracing indicated is to prevent buckling of individual truss web and/or chord members only. Additional temporary and permanent bracing is always required for stability and to prevent collapse with possible personal injury and property damage. For general guidance regarding the fabrication, storage, delivery, erection and bracing of trusses and truss systems, see

ANSI/TPI1 Quality Criteria, DSB-89 and BCSI Building Component

Safety Information available from Truss Plate Institute, 2670 Crain Highway, Suite 203 Waldorf, MD 20601



6904 Parke East Blvd.
Tampa, FL 33610

Job 3039076	Truss B04A	Truss Type Piggyback Base	Qty 1	Ply 1	Job Reference (optional)	T27365413
----------------	---------------	------------------------------	----------	----------	--------------------------	-----------

Builders FirstSource (Groveland, FL), Groveland, FL - 34736,

Run: 8:53 S Dec 6 2021 Print: 8:530 S Dec 6 2021 MiTek Industries, Inc. Wed Apr 06 15:10:02
ID:4UZgsYv9Jr8cG3VOll68hYzTT_q-RfC?PsB70Hq3NSgPqnL8w3uITXbGKWrCDoi7J4zJC7f

Page: 1

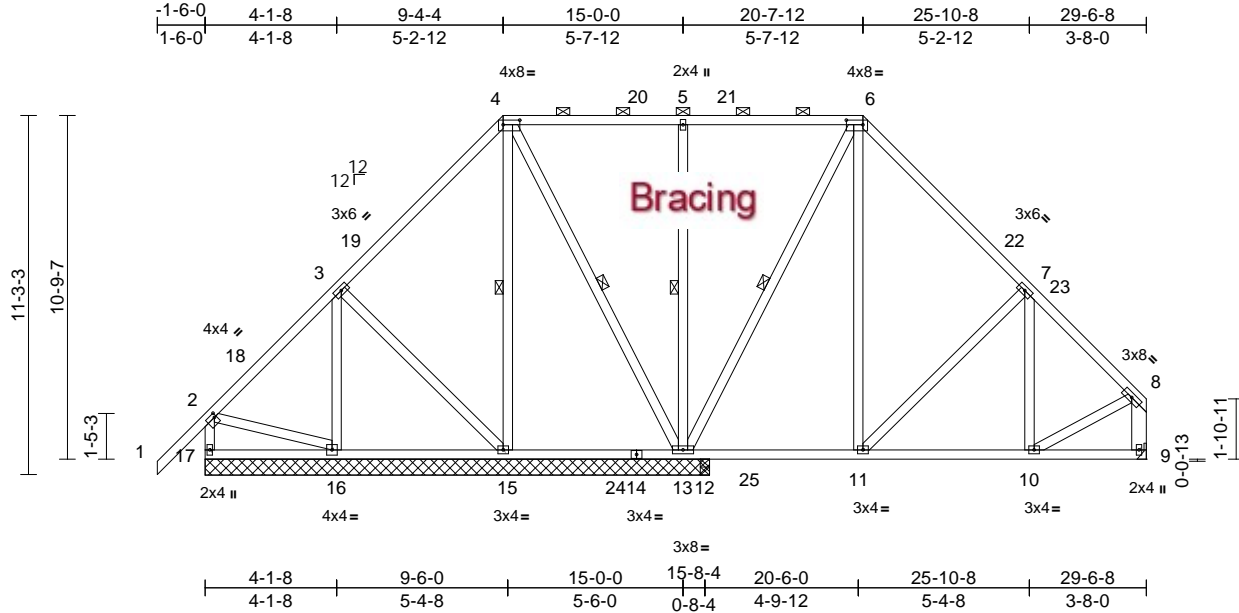

Scale = 1:72.3

Plate Offsets (X, Y): [2:0-0-12,0-1-8], [4:0-6-4,0-1-12], [6:0-6-4,0-1-12]

Loading	(psf)	Spacing	2-0-0	CSI	DEFL	in	(loc)	l/defl	L/d	PLATES	GRIP	
TCLL (roof)	20.0	Plate Grip DOL	1.25	TC	0.46	Vert(LL)	-0.03	13-15	>999	360	MT20	244/190
TCDL	10.0	Lumber DOL	1.25	BC	0.26	Vert(CT)	-0.04	13-15	>999	240		
BCLL	0.0*	Rep Stress Incr	YES	WB	0.41	Horz(CT)	-0.01	9	n/a	n/a		
BCDL	10.0	Code	FBC2020/TPI2014	Matrix-MS		Wind(LL)	0.02	10-11	>999	240	Weight: 235 lb	FT = 20%

LUMBER
TOP CHORD 2x4 SP No.2
BOT CHORD 2x4 SP No.2
WEBS 2x4 SP No.3 *Except* 9-8:2x6 SP No.2

BRACING
TOP CHORD Structural wood sheathing directly applied or 6-0-0 oc purlins, except end verticals, and 2-0-0 oc purlins (10-0-0 max.): 4-6.
BOT CHORD Rigid ceiling directly applied or 10-0-0 oc bracing, Except: 6-0-0 oc bracing: 16-17.
WEBS 1 Row at midpt 4-15, 4-13, 5-13, 6-13

REACTIONS (lb/size) 9=524/ Mechanical, 12=47/0-3-8, 13=923/15-10-0, 15=323/15-10-0, 16=298/15-10-0, 17=316/15-10-0
Max Horiz 17=481 (LC 7)
Max Uplift 9=208 (LC 11), 13=466 (LC 11), 15=224 (LC 10), 16=206 (LC 10), 17=112 (LC 6)
Max Grav 9=614 (LC 18), 12=99 (LC 16), 13=958 (LC 2), 15=475 (LC 17), 16=423 (LC 17), 17=336 (LC 18)

FORCES (lb) - Maximum Compression/Maximum Tension
TOP CHORD 1-2=0/70, 2-3=-225/152, 3-4=-178/178, 4-5=-87/212, 5-6=-87/212, 6-7=-394/280, 7-8=-531/202, 2-17=-291/157, 8-9=-568/219
BOT CHORD 16-17=-444/412, 15-16=-286/297, 13-15=-249/296, 12-13=-97/234, 11-12=-97/234, 10-11=-97/321, 9-10=-37/40
WEBS 4-15=-169/101, 4-13=-120/125, 5-13=-389/342, 6-13=-502/313, 6-11=-191/440, 2-16=-151/192, 8-10=-76/344, 3-15=-147/276, 3-16=-230/197, 7-11=-319/355, 7-10=-49/84

- Wind: ASCE 7-16; Vult=140mph (3-second gust) Vasd=108mph; TCDL=4.2psf; BCDL=5.0psf; h=25ft; Cat. II; Exp C; Enclosed; MWFRS (envelope) exterior zone and C-C Exterior(2E) -1-6-0 to 1-6-0, Interior (1) 1-6-0 to 5-1-5, Exterior(2R) 5-1-5 to 13-7-3, Interior (1) 13-7-3 to 16-4-13, Exterior(2R) 16-4-13 to 24-10-11, Interior (1) 24-10-11 to 26-3-12, Exterior(2E) 26-3-12 to 29-3-12 zone; end vertical left and right exposed; C-C for members and forces & MWFRS for reactions shown; Lumber DOL=1.60 plate grip DOL=1.60
- Building Designer / Project engineer responsible for verifying applied roof live load shown covers rain loading requirements specific to the use of this truss component.
- Provide adequate drainage to prevent water ponding.
- This truss has been designed for a 10.0 psf bottom chord live load nonconcurrent with any other live loads.
- * This truss has been designed for a live load of 20.0psf on the bottom chord in all areas where a rectangle 3-06-00 tall by 2-00-00 wide will fit between the bottom chord and any other members, with BCDL = 10.0psf.
- Refer to girder(s) for truss to truss connections.
- Provide mechanical connection (by others) of truss to bearing plate capable of withstanding 112 lb uplift at joint 17, 224 lb uplift at joint 15, 466 lb uplift at joint 13, 206 lb uplift at joint 16 and 208 lb uplift at joint 9.
- Graphical purlin representation does not depict the size or the orientation of the purlin along the top and/or bottom chord.

LOAD CASE(S) Standard

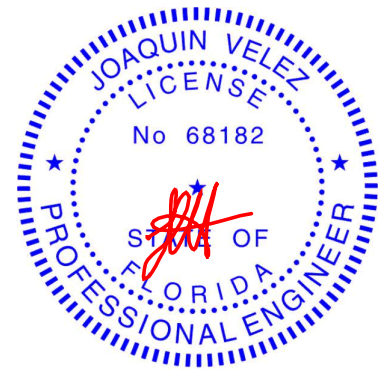

Joaquin Velez PE No.68182
MiTek USA, Inc. FL Cert 6634
6904 Parke East Blvd. Tampa FL 33610
Date:

April 7, 2022

WARNING - Verify design parameters and READ NOTES ON THIS AND INCLUDED MITEK REFERENCE PAGE MII-7473 rev. 5/19/2020 BEFORE USE.

Design valid for use only with MiTek® connectors. This design is based only upon parameters shown, and is for an individual building component, not a truss system. Before use, the building designer must verify the applicability of design parameters and properly incorporate this design into the overall building design. Bracing indicated is to prevent buckling of individual truss web and/or chord members only. Additional temporary and permanent bracing is always required for stability and to prevent collapse with possible personal injury and property damage. For general guidance regarding the fabrication, storage, delivery, erection and bracing of trusses and truss systems, see

ANSI/TPI1 Quality Criteria, DSB-89 and BCSI Building Component

Safety Information available from Truss Plate Institute, 2670 Crain Highway, Suite 203 Waldorf, MD 20601



6904 Parke East Blvd.
Tampa, FL 33610

Job 3039076	Truss B05	Truss Type Piggyback Base	Qty 1	Ply 1	Job Reference (optional)	T27365414
----------------	--------------	------------------------------	----------	----------	--------------------------	-----------

Builders FirstSource (Groveland, FL), Groveland, FL - 34736,

Run: 8:53 S Dec 6 2021 Print: 8:530 S Dec 6 2021 MiTek Industries, Inc. Wed Apr 06 15:10:02
ID:xD_XBQ2?nfAO7JlhUBwXQ?zTThr-RfC?PsB70Hq3NSgPqnL8w3uITxbGKwRCDoi7J4zJC?f

Page: 1

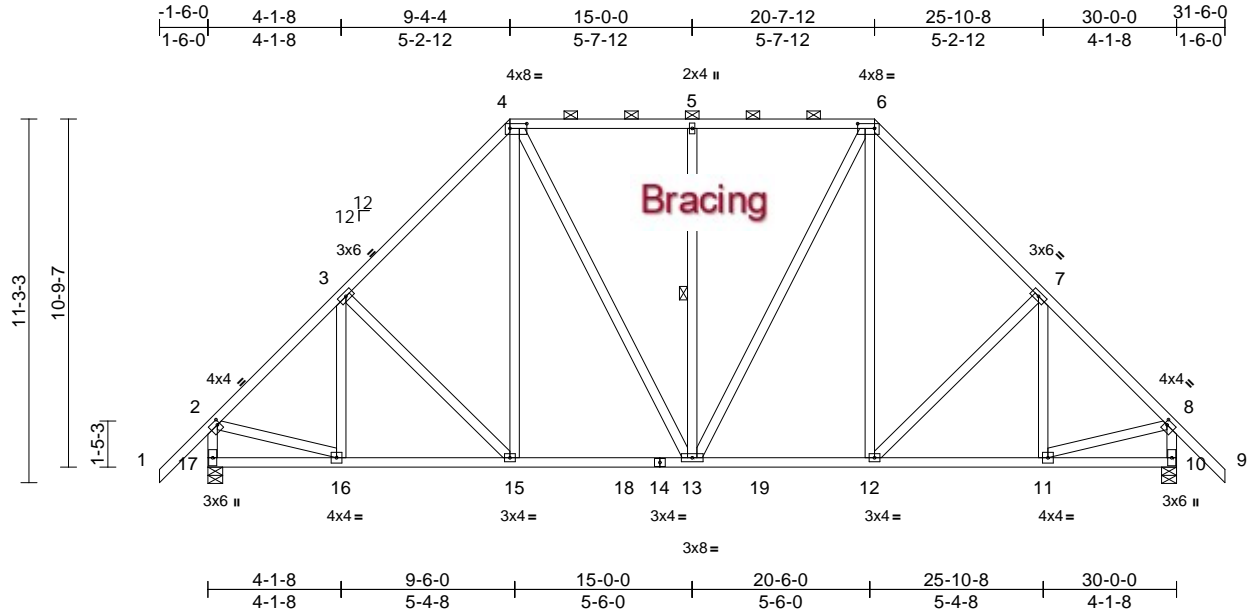

Scale = 1:71.4

Plate Offsets (X, Y): [2:0-1-0,0-1-12], [4:0-6-4,0-1-12], [6:0-6-4,0-1-12], [8:0-1-0,0-1-12]

Loading	(psf)	Spacing	2-0-0	CSI	DEFL	in (loc)	l/defl	L/d	PLATES	GRIP		
TCLL (roof)	20.0	Plate Grip DOL	1.25	TC	0.52	Vert(LL)	-0.06	12-13	>999	360	MT20	244/190
TCDL	10.0	Lumber DOL	1.25	BC	0.40	Vert(CT)	-0.10	12-13	>999	240		
BCLL	0.0*	Rep Stress Incr	YES	WB	0.83	Horz(CT)	0.03	10	n/a	n/a		
BCDL	10.0	Code	FBC2020/TPI2014	Matrix-MS		Wind(LL)	0.04	13-15	>999	240	Weight: 238 lb	FT = 20%

LUMBER
TOP CHORD 2x4 SP No.2
BOT CHORD 2x4 SP No.2
WEBS 2x4 SP No.3 *Except* 17-2,10-8:2x4 SP M 31

BRACING
TOP CHORD Structural wood sheathing directly applied or 4-4-6 oc purlins, except end verticals, and 2-0-0 oc purlins (5-3-4 max.): 4-6.
BOT CHORD Rigid ceiling directly applied or 8-3-12 oc bracing.
WEBS 1 Row at midpt 5-13

REACTIONS (lb/size) 10=1287/0-5-8, 17=1287/0-5-8
Max Horiz 17=492 (LC 9)
Max Uplift 10=553 (LC 11), 17=553 (LC 10)
Max Grav 10=1396 (LC 2), 17=1396 (LC 2)

FORCES (lb) - Maximum Compression/Maximum Tension
TOP CHORD 1-2=0/70, 2-3=-1325/507, 3-4=-1317/615, 4-5=-1143/590, 5-6=-1143/590, 6-7=-1318/615, 7-8=-1325/507, 8-9=0/70, 2-17=-1334/568, 8-10=-1334/567
BOT CHORD 16-17=-443/461, 15-16=-508/1079, 13-15=-390/893, 12-13=-248/821, 11-12=-189/892, 10-11=-23/101
WEBS 4-15=-179/418, 4-13=-311/359, 5-13=-387/340, 6-13=-311/359, 6-12=-179/418, 2-16=-212/914, 8-11=-208/914, 3-15=-319/336, 3-16=-152/114, 7-12=-319/336, 7-11=-152/114

NOTES
1) Unbalanced roof live loads have been considered for this design.

- 2) Wind: ASCE 7-16; Vult=140mph (3-second gust) Vasd=108mph; TCDL=4.2psf; BCDL=5.0psf; h=25ft; Cat. II; Exp C; Enclosed; MWFRS (envelope) exterior zone and C-C Exterior(2E) -1-6-0 to 1-6-0, Interior (1) 1-6-0 to 5-1-5, Exterior(2R) 5-1-5 to 13-7-3, Interior (1) 13-7-3 to 16-4-13, Exterior(2R) 16-4-13 to 24-10-11, Interior (1) 24-10-11 to 28-6-0, Exterior(2E) 28-6-0 to 31-6-0 zone; end vertical left and right exposed; C-C for members and forces & MWFRS for reactions shown; Lumber DOL=1.60 plate grip DOL=1.60
- 3) Building Designer / Project engineer responsible for verifying applied roof live load shown covers rain loading requirements specific to the use of this truss component.
- 4) Provide adequate drainage to prevent water ponding.
- 5) This truss has been designed for a 10.0 psf bottom chord live load nonconcurrent with any other live loads.
- 6) * This truss has been designed for a live load of 20.0psf on the bottom chord in all areas where a rectangle 3-06-00 tall by 2-00-00 wide will fit between the bottom chord and any other members, with BCDL = 10.0psf.
- 7) Provide mechanical connection (by others) of truss to bearing plate capable of withstanding 553 lb uplift at joint 17 and 553 lb uplift at joint 10.
- 8) Graphical purlin representation does not depict the size or the orientation of the purlin along the top and/or bottom chord.

LOAD CASE(S) Standard

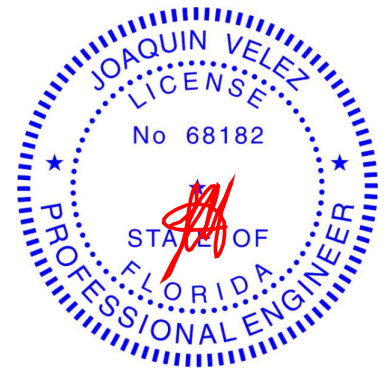

Joaquin Velez PE No.68182
MiTek USA, Inc. FL Cert 6634
6904 Parke East Blvd. Tampa FL 33610
Date:

April 7, 2022

WARNING - Verify design parameters and READ NOTES ON THIS AND INCLUDED MITEK REFERENCE PAGE MII-7473 rev. 5/19/2020 BEFORE USE.

Design valid for use only with MiTek® connectors. This design is based only upon parameters shown, and is for an individual building component, not a truss system. Before use, the building designer must verify the applicability of design parameters and properly incorporate this design into the overall building design. Bracing indicated is to prevent buckling of individual truss web and/or chord members only. Additional temporary and permanent bracing is always required for stability and to prevent collapse with possible personal injury and property damage. For general guidance regarding the fabrication, storage, delivery, erection and bracing of trusses and truss systems, see

ANSI/TPI1 Quality Criteria, DSB-89 and BCSI Building Component

Safety Information available from Truss Plate Institute, 2670 Crain Highway, Suite 203 Waldorf, MD 20601



6904 Parke East Blvd.
Tampa, FL 33610

Job 3039076	Truss B05A	Truss Type Piggyback Base	Qty 2	Ply 1	Job Reference (optional)	T27365415
----------------	---------------	------------------------------	----------	----------	--------------------------	-----------

Builders FirstSource (Groveland, FL), Groveland, FL - 34736,

Run: 8:53 S Dec 6 2021 Print: 8:53 S Dec 6 2021 MiTek Industries, Inc. Wed Apr 06 15:10:02
ID:XgFxBkXTDXF1ronKPFfjqzTTEp-RIC?PsB70Hq3NSgPqnL8w3ulTXbGKwRCDoi7J4zJC?f

Page: 1

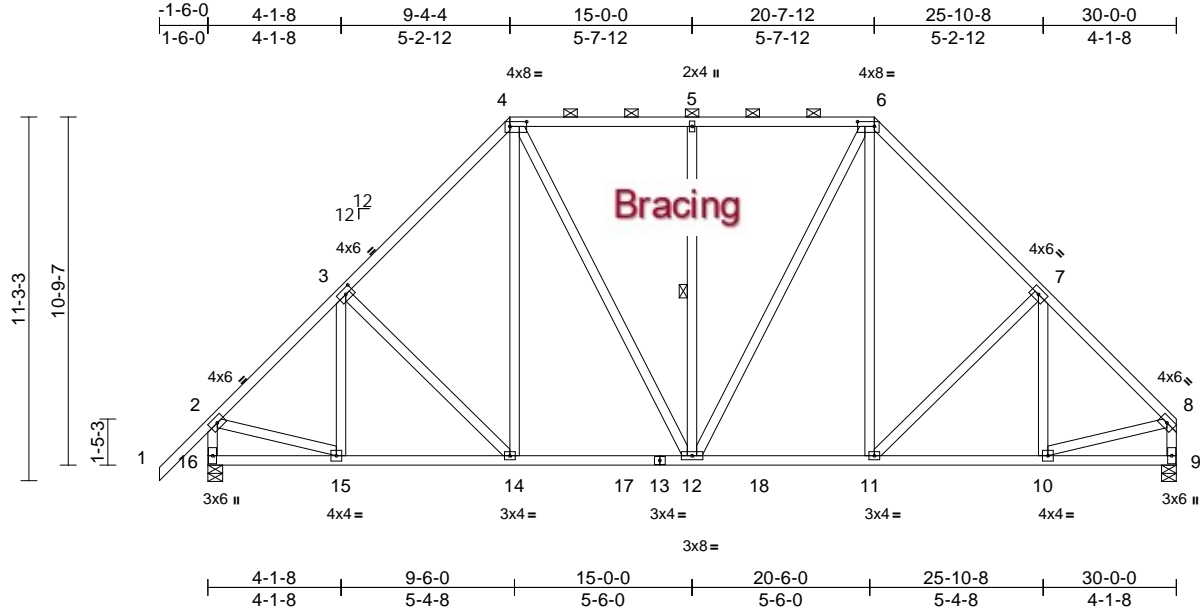

Scale = 1:71.4

Plate Offsets (X, Y): [3:0-0-0,0-0-0], [4:0-6-4,0-1-12], [6:0-6-4,0-1-12]

Loading	(psf)	Spacing	2-0-0	CSI	DEFL	in	(loc)	l/defl	L/d	PLATES	GRIP	
TCLL (roof)	20.0	Plate Grip DOL	1.25	TC	0.52	Vert(LL)	-0.06	11-12	>999	360	MT20	244/190
TCDL	10.0	Lumber DOL	1.25	BC	0.40	Vert(CT)	-0.10	11-12	>999	240		
BCLL	0.0*	Rep Stress Incr	YES	WB	0.83	Horz(CT)	0.03	9	n/a	n/a		
BCDL	10.0	Code	FBC2020/TPI2014	Matrix-MS		Wind(LL)	0.04	12-14	>999	240	Weight: 235 lb	FT = 20%

LUMBER
TOP CHORD 2x4 SP No.2
BOT CHORD 2x4 SP No.2
WEBS 2x4 SP No.3

BRACING
TOP CHORD Structural wood sheathing directly applied or 4-4-8 oc purlins, except end verticals, and 2-0-0 oc purlins (5-3-4 max.): 4-6.
BOT CHORD Rigid ceiling directly applied or 8-1-6 oc bracing.
WEBS 1 Row at midpt 5-12

REACTIONS
(lb/size) 9=1186/0-5-8, 16=1290/0-5-8
Max Horiz 16=470 (LC 9)
Max Uplift 9=-481 (LC 11), 16=-554 (LC 10)
Max Grav 9=1311 (LC 2), 16=1398 (LC 2)

FORCES
(lb) - Maximum Compression/Maximum Tension
TOP CHORD 1-2=0/70, 2-3=-1328/508, 3-4=-1318/615, 4-5=-1144/591, 5-6=-1144/591, 6-7=-1318/619, 7-8=-1335/503, 2-16=-1336/568, 8-9=-1249/494
BOT CHORD 15-16=-439/420, 14-15=-534/1049, 12-14=-416/863, 11-12=-274/826, 10-11=-281/905, 9-10=-49/44
WEBS 4-14=-179/417, 4-12=-311/362, 5-12=-387/341, 6-12=-311/358, 6-11=-184/427, 2-15=-210/917, 8-10=-243/900, 7-11=-321/343, 7-10=-147/126, 3-14=-320/335, 3-15=-152/114

NOTES
1) Unbalanced roof live loads have been considered for this design.

- 2) Wind: ASCE 7-16; Vult=140mph (3-second gust) Vasd=108mph; TCDL=4.2psf; BCDL=5.0psf; h=25ft; Cat. II; Exp C; Enclosed; MWFRS (envelope) exterior zone and C-C Exterior(2E) -1-6-0 to 1-6-0, Interior (1) 1-6-0 to 5-1-5, Exterior(2R) 5-1-5 to 13-7-3, Interior (1) 13-7-3 to 16-4-13, Exterior(2R) 16-4-13 to 24-10-11, Interior (1) 24-10-11 to 26-10-4, Exterior(2E) 26-10-4 to 29-10-4 zone; end vertical left and right exposed; C-C for members and forces & MWFRS for reactions shown; Lumber DOL=1.60 plate grip DOL=1.60
- 3) Building Designer / Project engineer responsible for verifying applied roof live load shown covers rain loading requirements specific to the use of this truss component.
- 4) Provide adequate drainage to prevent water ponding.
- 5) This truss has been designed for a 10.0 psf bottom chord live load nonconcurrent with any other live loads.
- 6) * This truss has been designed for a live load of 20.0psf on the bottom chord in all areas where a rectangle 3-06-00 tall by 2-00-00 wide will fit between the bottom chord and any other members, with BCDL = 10.0psf.
- 7) Provide mechanical connection (by others) of truss to bearing plate capable of withstanding 554 lb uplift at joint 16 and 481 lb uplift at joint 9.
- 8) Graphical purlin representation does not depict the size or the orientation of the purlin along the top and/or bottom chord.

LOAD CASE(S) Standard

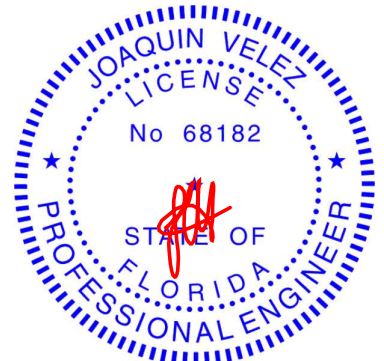

Joaquin Velez PE No.68182
MiTek USA, Inc. FL Cert 6634
6904 Parke East Blvd. Tampa FL 33610
Date:

April 7, 2022

WARNING - Verify design parameters and READ NOTES ON THIS AND INCLUDED MITEK REFERENCE PAGE MII-7473 rev. 5/19/2020 BEFORE USE.

Design valid for use only with MiTek® connectors. This design is based only upon parameters shown, and is for an individual building component, not a truss system. Before use, the building designer must verify the applicability of design parameters and properly incorporate this design into the overall building design. Bracing indicated is to prevent buckling of individual truss web and/or chord members only. Additional temporary and permanent bracing is always required for stability and to prevent collapse with possible personal injury and property damage. For general guidance regarding the fabrication, storage, delivery, erection and bracing of trusses and truss systems, see

ANSI/TPI1 Quality Criteria, DSB-89 and BCSI Building Component

Safety Information available from Truss Plate Institute, 2670 Crain Highway, Suite 203 Waldorf, MD 20601



6904 Parke East Blvd.
Tampa, FL 33610

Job 3039076	Truss B06	Truss Type Piggyback Base	Qty 4	Ply 1	Job Reference (optional)	T27365416
----------------	--------------	------------------------------	----------	----------	--------------------------	-----------

Builders FirstSource (Groveland, FL), Groveland, FL - 34736,

Run: 8.53 S Dec 6 2021 Print: 8.530 S Dec 6 2021 MiTek Industries, Inc. Wed Apr 06 15:10:03
ID: B472ySao34f_N3tQUXbdAOzTTY6-RfC?PsB70Hq3NSgPqnL8w3uITXbGKwRCDoi7J4zJC?f

Page: 1

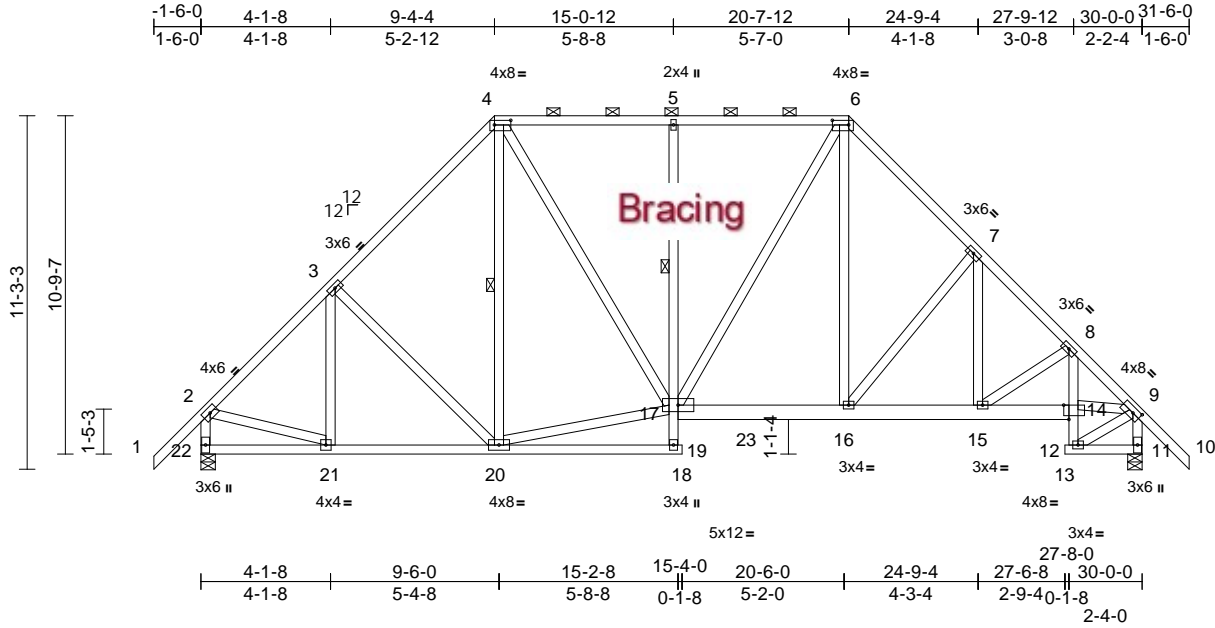

Scale = 1:73.4

Plate Offsets (X, Y): [4:0-6-4,0-1-12], [6:0-6-4,0-1-12], [9:0-2-15,0-2-0], [14:0-2-0,Edge]

Loading	(psf)	Spacing	2-0-0	CSI	DEFL	in (loc)	l/defl	L/d	PLATES	GRIP		
TCLL (roof)	20.0	Plate Grip DOL	1.25	TC	0.52	Vert(LL)	-0.05	16-17	>999	360	MT20	244/190
TCDL	10.0	Lumber DOL	1.25	BC	0.37	Vert(CT)	-0.10	19-20	>999	240		
BCLL	0.0*	Rep Stress Incr	YES	WB	0.69	Horz(CT)	0.06	11	n/a	n/a		
BCDL	10.0	Code	FBC2020/TPI2014	Matrix-MS		Wind(LL)	0.05	5-17	>999	240	Weight: 259 lb	FT = 20%

LUMBER
TOP CHORD 2x4 SP No.2
BOT CHORD 2x4 SP No.2 *Except* 19-5,8-12:2x4 SP No.3, 17-14:2x6 SP No.2
WEBS 2x4 SP No.3
BRACING
TOP CHORD Structural wood sheathing directly applied or 4-4-6 oc purlins, except end verticals, and 2-0-0 oc purlins (5-0-9 max.): 4-6.
BOT CHORD Rigid ceiling directly applied or 6-0-0 oc bracing. Except:
1 Row at midpt 5-17
6-0-0 oc bracing: 12-14
10-0-0 oc bracing: 17-19
WEBS 1 Row at midpt 4-20
REACTIONS (lb/size) 11=1295/0-5-8, 22=1290/0-5-8
Max Horiz 22=492 (LC 9)
Max Uplift 11=549 (LC 11), 22=553 (LC 10)
Max Grav 11=1388 (LC 2), 22=1367 (LC 2)
FORCES (lb) - Maximum Compression/Maximum Tension
TOP CHORD 1-2=0/70, 2-3=-1294/507, 3-4=-1326/617, 4-5=-1235/591, 5-6=-1237/590, 6-7=-1445/634, 7-8=-1576/598, 8-9=-1741/578, 9-10=0/70, 2-22=-1305/568, 9-11=-1362/562
BOT CHORD 21-22=-445/462, 20-21=-507/1057, 19-20=-18/78, 18-19=0/0, 17-19=0/119, 5-17=-395/345, 16-17=-279/911, 15-16=-212/1076, 14-15=-281/1219, 12-14=-20/56, 8-14=0/141, 12-13=0/0, 11-12=-44/63

WEBS 4-20=-142/227, 17-20=-378/805, 4-17=-275/529, 6-17=-316/346, 6-16=-217/541, 2-21=-210/892, 3-20=-317/337, 3-21=-154/112, 7-16=-453/355, 7-15=-32/190, 8-15=-282/143, 9-12=-89/122, 9-14=-250/1120
NOTES
1) Unbalanced roof live loads have been considered for this design.
2) Wind: ASCE 7-16; Vult=140mph (3-second gust) Vasd=108mph; TCDL=4.2psf; BCDL=5.0psf; h=25ft; Cat. II; Exp C; Enclosed; MWFRS (envelope) exterior zone and C-C Exterior(2E) -1-6-0 to 1-6-0, Interior (1) 1-6-0 to 5-1-5, Exterior(2R) 5-1-5 to 13-7-3, Interior (1) 13-7-3 to 16-4-13, Exterior(2R) 16-4-13 to 24-9-4, Interior (1) 24-9-4 to 28-6-0, Exterior(2E) 28-6-0 to 31-6-0 zone; end vertical left and right exposed; C-C for members and forces & MWFRS for reactions shown; Lumber DOL=1.60 plate grip DOL=1.60
3) Building Designer / Project engineer responsible for verifying applied roof live load shown covers rain loading requirements specific to the use of this truss component.
4) Provide adequate drainage to prevent water ponding.
5) This truss has been designed for a 10.0 psf bottom chord live load nonconcurrent with any other live loads.
6) * This truss has been designed for a live load of 20.0psf on the bottom chord in all areas where a rectangle 3-06-00 tall by 2-00-00 wide will fit between the bottom chord and any other members, with BCDL = 10.0psf.
7) Provide mechanical connection (by others) of truss to bearing plate capable of withstanding 553 lb uplift at joint 22 and 549 lb uplift at joint 11.
8) Graphical purlin representation does not depict the size or the orientation of the purlin along the top and/or bottom chord.

LOAD CASE(S) Standard

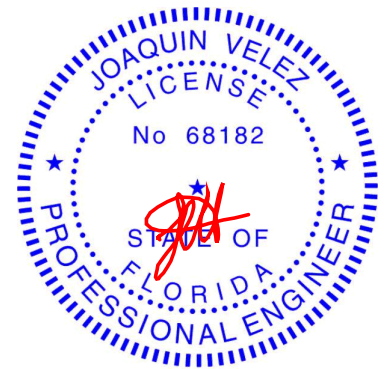

Joaquin Velez PE No.68182
MiTek USA, Inc. FL Cert 6634
6904 Parke East Blvd. Tampa FL 33610
Date:

April 7, 2022

WARNING - Verify design parameters and READ NOTES ON THIS AND INCLUDED MITEK REFERENCE PAGE MII-7473 rev. 5/19/2020 BEFORE USE.

Design valid for use only with MiTek® connectors. This design is based only upon parameters shown, and is for an individual building component, not a truss system. Before use, the building designer must verify the applicability of design parameters and properly incorporate this design into the overall building design. Bracing indicated is to prevent buckling of individual truss web and/or chord members only. Additional temporary and permanent bracing is always required for stability and to prevent collapse with possible personal injury and property damage. For general guidance regarding the fabrication, storage, delivery, erection and bracing of trusses and truss systems, see ANSITPI1 Quality Criteria, DSB-89 and BCSI Building Component Safety Information available from Truss Plate Institute, 2670 Crain Highway, Suite 203 Waldorf, MD 20601



6904 Parke East Blvd.
Tampa, FL 33610

Job 3039076	Truss B06A	Truss Type Piggyback Base	Qty 2	Ply 1	Job Reference (optional)	T27365417
----------------	---------------	------------------------------	----------	----------	--------------------------	-----------

Builders FirstSource (Groveland, FL), Groveland, FL - 34736,

Run: 8.53 S Dec 6 2021 Print: 8.530 S Dec 6 2021 MiTek Industries, Inc. Wed Apr 06 15:10:03
ID:wdrnWNUKMY6nofej16z1CxzTTGM-RfC?PsB70Hq3NSgPqnL8w3uITXbGKwRCDoi7J4zJC?f

Page: 1

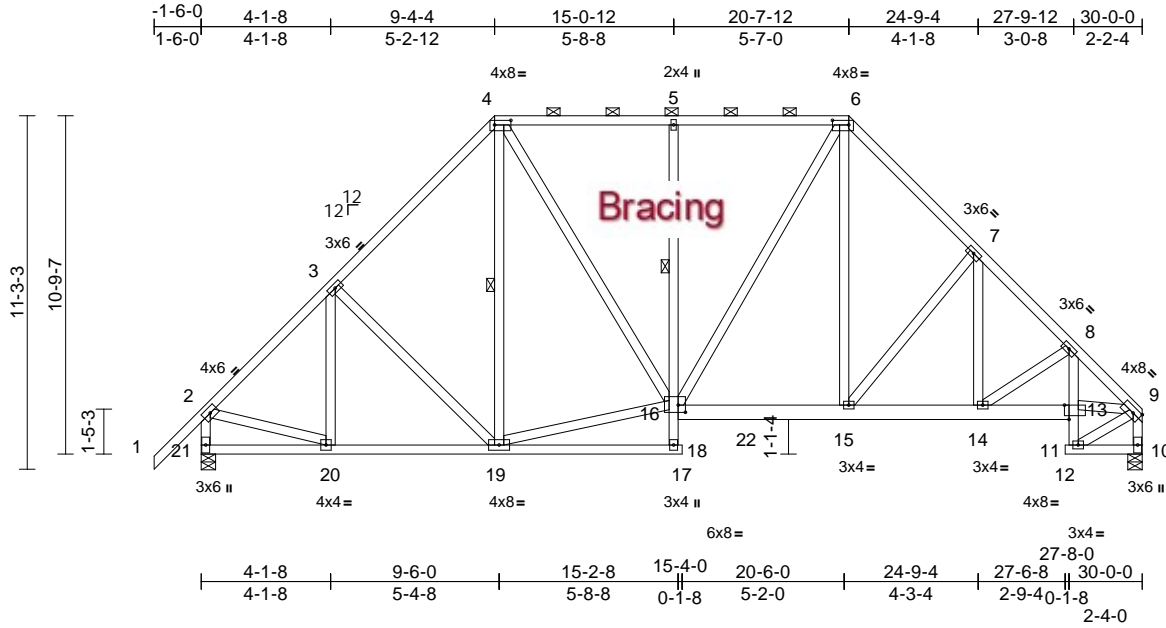

Scale = 1:73.4

Plate Offsets (X, Y): [4:0-6-4,0-1-12], [6:0-6-4,0-1-12], [9:0-2-15,Edge], [13:0-1-12,Edge], [16:0-2-12,0-2-12]

Loading	(psf)	Spacing	2-0-0	CSI	DEFL	in	(loc)	l/defl	L/d	PLATES	GRIP	
TCLL (roof)	20.0	Plate Grip DOL	1.25	TC	0.52	Vert(LL)	-0.05	15-16	>999	360	MT20	244/190
TCDL	10.0	Lumber DOL	1.25	BC	0.37	Vert(CT)	-0.10	18-19	>999	240		
BCLL	0.0*	Rep Stress Incr	YES	WB	0.69	Horz(CT)	0.06	10	n/a	n/a		
BCDL	10.0	Code	FBC2020/TPI2014	Matrix-MS		Wind(LL)	0.05	5-16	>999	240	Weight: 256 lb	FT = 20%

LUMBER	
TOP CHORD	2x4 SP No.2
BOT CHORD	2x4 SP No.2 *Except* 18-5,8-11:2x4 SP No.3, 16-13:2x6 SP No.2
WEBS	2x4 SP No.3
BRACING	
TOP CHORD	Structural wood sheathing directly applied or 4-4-6 oc purlins, except end verticals, and 2-0-0 oc purlins (5-0-11 max.): 4-6.
BOT CHORD	Rigid ceiling directly applied or 10-0-0 oc bracing, Except: 8-11-3 oc bracing: 20-21 8-1-3 oc bracing: 19-20.
1 Row at midpt	5-16 6-0-0 oc bracing: 11-13 10-0-0 oc bracing: 16-18
WEBS	1 Row at midpt 4-19
REACTIONS	(lb/size)
	10=1193/0-5-8, 21=1293/0-5-8
	Max Horiz 21=470 (LC 7)
	Max Uplift 10=477 (LC 11), 21=553 (LC 10)
	Max Grav 10=1303 (LC 2), 21=1370 (LC 2)
FORCES	(lb) - Maximum Compression/Maximum Tension
TOP CHORD	1-2=0/70, 2-3=-1297/507, 3-4=-1326/617, 4-5=-1228/600, 5-6=-1229/600, 6-7=-1435/651, 7-8=-1578/634, 8-9=-1777/652, 2-21=-1308/568, 9-10=-1276/488
BOT CHORD	20-21=-439/421, 19-20=-533/1027, 18-19=-20/78, 17-18=0/0, 16-18=0/119, 5-16=-395/345, 15-16=-309/916, 14-15=-270/1086, 13-14=-434/1252, 11-13=-15/36, 8-13=-4/147, 11-12=0/0, 10-11=-27/21

WEBS	
	4-19=-133/237, 16-19=-403/775, 4-16=-286/532, 6-16=-316/345, 6-15=-230/551, 2-20=-211/894, 9-11=-47/93, 3-19=-317/337, 3-20=-155/112, 7-15=-444/372, 8-14=-253/197, 7-14=-60/211, 9-13=-403/1155

- NOTES**
- Unbalanced roof live loads have been considered for this design.
 - Wind: ASCE 7-16; Vult=140mph (3-second gust) Vasd=108mph; TCDL=4.2psf; BCDL=5.0psf; h=25ft; Cat. II; Exp C; Enclosed; MWFRS (envelope) exterior zone and C-C Exterior(2E) -1-6-0 to 1-6-0, Interior (1) 1-6-0 to 5-1-5, Exterior(2R) 5-1-5 to 13-7-3, Interior (1) 13-7-3 to 16-4-13, Exterior(2R) 16-4-13 to 24-9-4, Interior (1) 24-9-4 to 26-10-4, Exterior(2E) 26-10-4 to 29-10-4 zone; end vertical left and right exposed; C-C for members and forces & MWFRS for reactions shown; Lumber DOL=1.60 plate grip DOL=1.60
 - Building Designer / Project engineer responsible for verifying applied roof live load shown covers rain loading requirements specific to the use of this truss component.
 - Provide adequate drainage to prevent water ponding.
 - This truss has been designed for a 10.0 psf bottom chord live load nonconcurrent with any other live loads.
 - * This truss has been designed for a live load of 20.0psf on the bottom chord in all areas where a rectangle 3-06-00 tall by 2-00-00 wide will fit between the bottom chord and any other members, with BCDL = 10.0psf.
 - Provide mechanical connection (by others) of truss to bearing plate capable of withstanding 553 lb uplift at joint 21 and 477 lb uplift at joint 10.
 - Graphical purlin representation does not depict the size or the orientation of the purlin along the top and/or bottom chord.
 - Attic room checked for L/360 deflection.

LOAD CASE(S) Standard

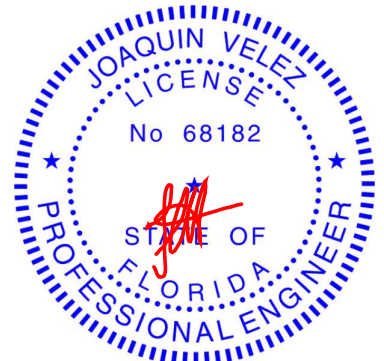

Joaquin Velez PE No.68182
MiTek USA, Inc. FL Cert 6634
6904 Parke East Blvd. Tampa FL 33610
Date:

April 7, 2022

WARNING - Verify design parameters and READ NOTES ON THIS AND INCLUDED MITEK REFERENCE PAGE MII-7473 rev. 5/19/2020 BEFORE USE.

Design valid for use only with MiTek® connectors. This design is based only upon parameters shown, and is for an individual building component, not a truss system. Before use, the building designer must verify the applicability of design parameters and properly incorporate this design into the overall building design. Bracing indicated is to prevent buckling of individual truss web and/or chord members only. Additional temporary and permanent bracing is always required for stability and to prevent collapse with possible personal injury and property damage. For general guidance regarding the fabrication, storage, delivery, erection and bracing of trusses and truss systems, see ANSI/TPI1 Quality Criteria, DSB-89 and BCSI Building Component Safety Information available from Truss Plate Institute, 2670 Crain Highway, Suite 203 Waldorf, MD 20601



6904 Parke East Blvd.
Tampa, FL 33610

Job 3039076	Truss B07	Truss Type Piggyback Base Structural Gable	Qty 1	Ply 1	Job Reference (optional) T27365418
----------------	--------------	---	----------	----------	---------------------------------------

Builders FirstSource (Groveland, FL), Groveland, FL - 34736,

Run: 8.53 S Dec 6 2021 Print: 8.530 S Dec 6 2021 MiTek Industries, Inc. Wed Apr 06 15:10:04
ID:DLV2mZ8vjhdhJSvui95e5zTTpT-RfC?PsB70Hq3NSgPqnL8w3uITXbGKWRcDoi7J4zJC?#

Page: 1

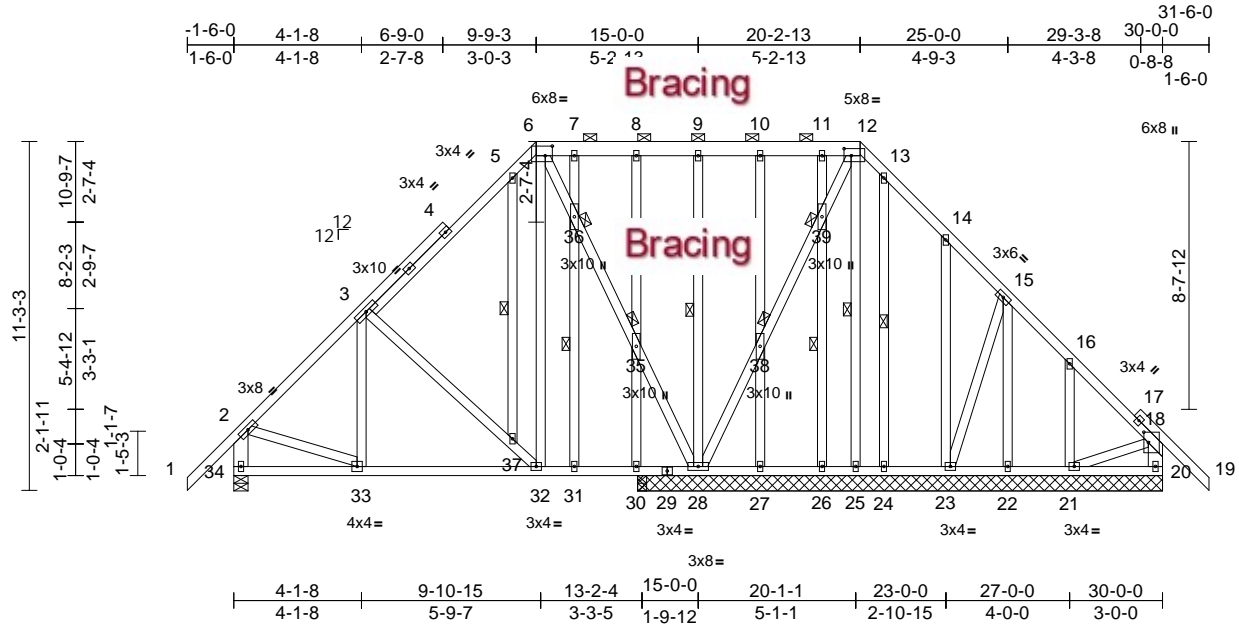

Scale = 1:74.4

Plate Offsets (X, Y): [6:0-2-12,0-3-12], [12:0-2-12,0-2-12], [18:0-4-0,0-1-12]

Loading	(psf)	Spacing	2-0-0	CSI	DEFL	in	(loc)	l/defl	L/d	PLATES	GRIP	
TCLL (roof)	20.0	Plate Grip DOL	1.25	TC	0.38	Vert(LL)	-0.03	32-33	>999	360	MT20	244/190
TCDL	10.0	Lumber DOL	1.25	BC	0.26	Vert(CT)	-0.06	32-33	>999	240		
BCLL	0.0*	Rep Stress Incr	YES	WB	0.49	Horz(CT)	0.01	20	n/a	n/a		
BCDL	10.0	Code	FBC2020/TPI2014	Matrix-MS		Wind(LL)	0.03	32-33	>999	240	Weight: 354 lb	FT = 20%

LUMBER	TOP CHORD	2x4 SP No.2 *Except* 6-12:2x6 SP No.2	TOP CHORD	1-2=0/73, 2-3=-478/203, 3-5=-334/225, 5-6=-322/275, 6-7=-100/230, 7-8=-101/231, 8-9=-101/231, 9-10=-101/231, 10-11=-101/231, 11-12=-101/231, 12-13=-157/290, 13-14=-109/218, 14-15=-23/127, 15-16=-63/102, 16-18=-247/249, 18-19=0/69, 2-34=-584/257, 18-20=-208/210	2) Wind: ASCE 7-16; Vult=140mph (3-second gust) Vasd=108mph; TC DL=4.2psf; BCDL=5.0psf; h=25ft; Cat. II; Exp C; Enclosed; MWFRS (envelope) exterior zone and C-C Exterior(2E) -1-6-0 to 1-6-0, Interior (1) 1-6-0 to 5-6-5, Exterior(2R) 5-6-5 to 14-0-2, Interior (1) 14-0-2 to 15-11-14, Exterior(2R) 15-11-14 to 24-5-11, Interior (1) 24-5-11 to 28-6-0, Exterior(2E) 28-6-0 to 31-6-0 zone; end vertical left and right exposed; C-C for members and forces & MWFRS for reactions shown; Lumber DOL=1.60 plate grip DOL=1.60
BOT CHORD	2x4 SP No.2	BOT CHORD	33-34=-440/452, 32-33=-291/509, 31-32=-208/365, 30-31=-208/365, 28-30=-208/365, 27-28=-269/369, 26-27=-269/369, 25-26=-269/369, 24-25=-270/370, 23-24=-270/370, 22-23=-217/316, 21-22=-217/316, 20-21=-25/78	3) Truss designed for wind loads in the plane of the truss only. For studs exposed to wind (normal to the face), see Standard Industry Gable End Details as applicable, or consult qualified building designer as per ANSI/TPI 1.	
WEBS	2x4 SP No.3 *Except* 34-2,20-18:2x6 SP No.2	WEBS	6-32=-206/393, 6-36=-525/355, 35-36=-578/392, 28-35=-564/382, 9-28=-122/109, 28-38=-91/44, 38-39=-94/46, 12-39=-83/39, 12-25=-119/65, 2-33=-49/320, 3-37=-419/360, 32-37=-472/414, 3-33=0/142, 8-35=-145/132, 30-35=-157/131, 7-36=-46/36, 31-36=-70/78, 5-37=-79/81, 10-38=-136/114, 27-38=-140/117, 11-39=-93/84, 26-39=-85/79, 13-24=-108/95, 14-23=-229/236, 15-22=-55/3, 16-21=-249/226, 18-21=-318/305, 15-23=-158/180	4) Building Designer / Project engineer responsible for verifying applied roof live load shown covers rain loading requirements specific to the use of this truss component.	
OTHERS	2x4 SP No.3	OTHERS		5) Provide adequate drainage to prevent water ponding.	
BRACING		BRACING		6) All plates are 2x4 MT20 unless otherwise indicated.	
TOP CHORD	Structural wood sheathing directly applied or 6-0-0 oc purlins, except end verticals, and 2-0-0 oc purlins (10-0-0 max.): 6-12.	TOP CHORD		7) Truss to be fully sheathed from one face or securely braced against lateral movement (i.e. diagonal web).	
BOT CHORD	Rigid ceiling directly applied or 6-0-0 oc bracing.	BOT CHORD		8) Gable studs spaced at 24-0-0 oc.	
WEBS	1 Row at midpt 9-28, 12-25, 31-36, 5-37, 26-39, 13-24	WEBS			
JOINTS	1 Brace at Jt(s): 35, 36, 38, 39	JOINTS			
REACTIONS	(lb/size) 20=197/16-11-8, 21=182/16-11-8, 22=76/16-11-8, 23=226/16-11-8, 24=115/16-11-8, 25=45/16-11-8, 26=115/16-11-8, 27=168/16-11-8, 28=645/16-11-8, 30=193/16-11-8, 34=609/0-5-8	REACTIONS			
	Max Horiz 34=489 (LC 8)				
	Max Uplift 20=8 (LC 7), 21=-315 (LC 11), 23=-385 (LC 11), 24=-79 (LC 11), 25=-46 (LC 9), 26=-61 (LC 7), 27=-96 (LC 11), 28=-436 (LC 10), 30=-131 (LC 6), 34=-240 (LC 10)				
	Max Grav 20=234 (LC 22), 21=265 (LC 18), 22=90 (LC 22), 23=312 (LC 18), 24=131 (LC 18), 25=124 (LC 11), 26=119 (LC 22), 27=169 (LC 21), 28=645 (LC 1), 30=209 (LC 22), 34=613 (LC 21)				
FORCES	(lb) - Maximum Compression/Maximum Tension	NOTES	1) Unbalanced roof live loads have been considered for this design.		



Joaquin Velez PE No.68182
MiTek USA, Inc. FL Cert 6634
6904 Parke East Blvd. Tampa FL 33610
Date:

April 7, 2022

Continued on page 2

WARNING - Verify design parameters and READ NOTES ON THIS AND INCLUDED MITEK REFERENCE PAGE MII-7473 rev. 5/19/2020 BEFORE USE.

Design valid for use only with MiTek® connectors. This design is based only upon parameters shown, and is for an individual building component, not a truss system. Before use, the building designer must verify the applicability of design parameters and properly incorporate this design into the overall building design. Bracing indicated is to prevent buckling of individual truss web and/or chord members only. Additional temporary and permanent bracing is always required for stability and to prevent collapse with possible personal injury and property damage. For general guidance regarding the fabrication, storage, delivery, erection and bracing of trusses and truss systems, see **ANSI/TPI1 Quality Criteria, DSB-89 and BCSI Building Component Safety Information** available from Truss Plate Institute, 2670 Crain Highway, Suite 203 Waldorf, MD 20601



6904 Parke East Blvd.
Tampa, FL 33610

Job	Truss	Truss Type	Qty	Ply	Job Reference (optional)
3039076	B07	Piggyback Base Structural Gable	1	1	T27365418

Builders FirstSource (Groveland, FL), Groveland, FL - 34736,

Run: 8.53 S Dec 6 2021 Print: 8.530 S Dec 6 2021 MiTek Industries, Inc. Wed Apr 06 15:10:04
 ID:DLV2mZ8vjhdbJSvui95e5zTTPt-RfC?PsB70Hq3NSgPqnL8w3ulTXbGKWrCDoi7J4zJC?#

Page: 2

- 9) This truss has been designed for a 10.0 psf bottom chord live load nonconcurrent with any other live loads.
- 10) * This truss has been designed for a live load of 20.0psf on the bottom chord in all areas where a rectangle 3-06-00 tall by 2-00-00 wide will fit between the bottom chord and any other members.
- 11) Provide mechanical connection (by others) of truss to bearing plate capable of withstanding 240 lb uplift at joint 34, 436 lb uplift at joint 28, 46 lb uplift at joint 25, 8 lb uplift at joint 20, 131 lb uplift at joint 30, 96 lb uplift at joint 27, 61 lb uplift at joint 26, 79 lb uplift at joint 24, 385 lb uplift at joint 23 and 315 lb uplift at joint 21.
- 12) Graphical purlin representation does not depict the size or the orientation of the purlin along the top and/or bottom chord.

LOAD CASE(S) Standard

WARNING - Verify design parameters and READ NOTES ON THIS AND INCLUDED MITEK REFERENCE PAGE MII-7473 rev. 5/19/2020 BEFORE USE.

Design valid for use only with MiTek® connectors. This design is based only upon parameters shown, and is for an individual building component, not a truss system. Before use, the building designer must verify the applicability of design parameters and properly incorporate this design into the overall building design. Bracing indicated is to prevent buckling of individual truss web and/or chord members only. Additional temporary and permanent bracing is always required for stability and to prevent collapse with possible personal injury and property damage. For general guidance regarding the fabrication, storage, delivery, erection and bracing of trusses and truss systems, see **ANSI/TPI1 Quality Criteria, DSB-89 and BCSI Building Component Safety Information** available from Truss Plate Institute, 2670 Crain Highway, Suite 203 Waldorf, MD 20601



6904 Parke East Blvd.
Tampa, FL 36610

Job	Truss	Truss Type	Qty	Ply	
3039076	B08	Piggyback Base Supported Gable	1	1	T27365419
					Job Reference (optional)

Builders FirstSource (Groveland, FL), Groveland, FL - 34736,

Run: 8.53 S Dec 6 2021 Print: 8.530 S Dec 6 2021 MiTek Industries, Inc. Wed Apr 06 15:10:04

Page: 1

ID: rY3gfYKMKn63ZckCIFyMBjzTSfd-RfC?PsB70Hq3NSgPqnL8w3uITXbGKWrCDoi7J4zJC?

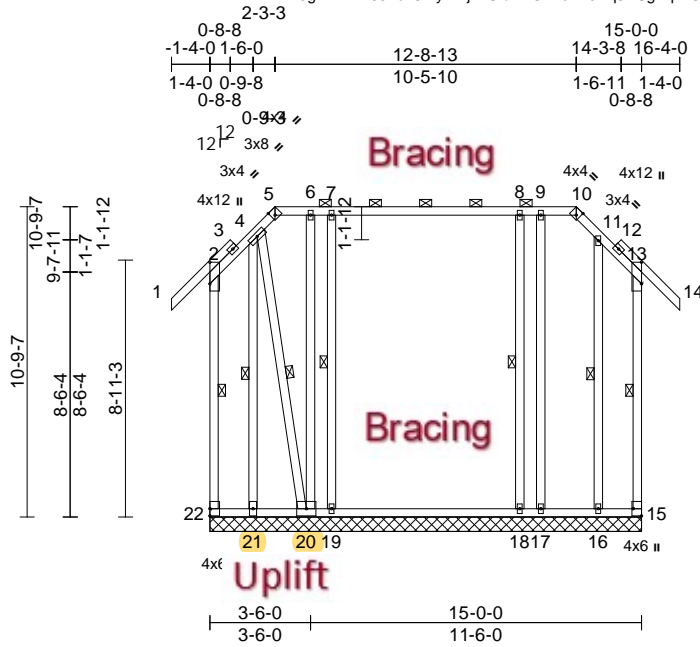

Scale = 1:80.1

Plate Offsets (X, Y): [2:0-9-0,Edge], [5:0-1-8,Edge], [10:0-1-8,Edge], [13:0-9-0,Edge], [15:Edge,0-3-8]

Loading	(psf)	Spacing	2-0-0	CSI	DEFL	in	(loc)	l/defl	L/d	PLATES	GRIP	
TCLL (roof)	20.0	Plate Grip DOL	1.25	TC	0.42	Vert(LL)	n/a	-	n/a	999	MT20	244/190
TCDL	10.0	Lumber DOL	1.25	BC	0.40	Vert(CT)	n/a	-	n/a	999		
BCLL	0.0*	Rep Stress Incr	YES	WB	0.92	Horz(CT)	-0.01	15	n/a	n/a		
BCDL	10.0	Code	FBC2020/TPI2014	Matrix-MS							Weight: 185 lb	FT = 20%

LUMBER	
TOP CHORD	2x4 SP No.2
BOT CHORD	2x4 SP No.2
WEBS	2x4 SP M 31 *Except* 20-4:2x4 SP No.3
OTHERS	2x4 SP No.3

WEBS	
7-19	=405/528, 8-18=-406/531,
6-20	=376/189, 4-21=-1664/1750,
9-17	=386/193, 11-16=-511/180,
4-20	=1793/1796

- 12) Provide mechanical connection (by others) of truss to bearing plate capable of withstanding 285 lb uplift at joint 22, 214 lb uplift at joint 15, 398 lb uplift at joint 19, 314 lb uplift at joint 18, 1619 lb uplift at joint 20, 1481 lb uplift at joint 21 and 366 lb uplift at joint 17.
- 13) Graphical purlin representation does not depict the size or the orientation of the purlin along the top and/or bottom chord.
- 14) This truss has large uplift reaction(s) from gravity load case(s). Proper connection is required to secure truss against upward movement at the bearings. Building designer must provide for uplift reactions indicated.

LOAD CASE(S) Standard

BRACING	
TOP CHORD	Structural wood sheathing directly applied or 6-0-0 oc purlins, except end verticals, and 2-0-0 oc purlins (6-0-0 max.): 5-10.
BOT CHORD	Rigid ceiling directly applied or 6-0-0 oc bracing.
WEBS	1 Row at midpt 2-22, 13-15, 7-19, 8-18, 4-21, 11-16, 4-20
REACTIONS (lb/size)	
Max Horiz	15=179/15-0-0, 16=77/15-0-0, 17=-139/15-0-0, 18=561/15-0-0, 19=546/15-0-0, 20=-127/15-0-0, 21=76/15-0-0, 22=182/15-0-0
Max Uplift	22=608 (LC 8) 15=-214 (LC 11), 17=-366 (LC 18), 18=-314 (LC 6), 19=-398 (LC 7), 20=-1619 (LC 9), 21=-1481 (LC 8), 22=-285 (LC 10)
Max Grav	15=268 (LC 18), 16=136 (LC 18), 17=186 (LC 6), 18=756 (LC 23), 19=715 (LC 24), 20=1470 (LC 6), 21=1593 (LC 9), 22=231 (LC 18)

NOTES

- 1) Unbalanced roof live loads have been considered for this design.
- 2) Wind: ASCE 7-16; Vult=140mph (3-second gust) Vasd=108mph; TC DL=4.2psf; BCDL=5.0psf; h=25ft; Cat. II; Exp C; Enclosed: MWFRS (envelope) exterior zone and C-C Corner(3E) -1-4-0 to 1-6-7, Corner(3R) 1-6-7 to 5-3-3, Exterior(2N) 5-3-3 to 9-8-13, Corner(3R) 9-8-13 to 13-6-0, Corner(3E) 13-6-0 to 16-4-0 zone; end vertical left and right exposed; C-C for members and forces & MWFRS for reactions shown; Lumber DOL=1.60 plate grip DOL=1.60
- 3) Truss designed for wind loads in the plane of the truss only. For studs exposed to wind (normal to the face), see Standard Industry Gable End Details as applicable, or consult qualified building designer as per ANSI/TPI 1.
- 4) Building Designer / Project engineer responsible for verifying applied roof live load shown covers rain loading requirements specific to the use of this truss component.
- 5) Provide adequate drainage to prevent water ponding.
- 6) All plates are 2x4 MT20 unless otherwise indicated.
- 7) Gable requires continuous bottom chord bearing.
- 8) Truss to be fully sheathed from one face or securely braced against lateral movement (i.e. diagonal web).
- 9) Gable studs spaced at 2-0-0 oc.
- 10) This truss has been designed for a 10.0 psf bottom chord live load nonconcurrent with any other live loads.
- 11) * This truss has been designed for a live load of 20.0psf on the bottom chord in all areas where a rectangle 3-06-00 tall by 2-00-00 wide will fit between the bottom chord and any other members, with BCDL = 10.0psf.

FORCES	(lb) - Maximum Compression/Maximum Tension
TOP CHORD	2-22=-362/1011, 1-2=0/58, 2-4=-369/888, 4-5=-237/528, 5-6=-253/577, 6-7=-251/571, 7-8=-251/571, 8-9=-251/571, 9-10=-251/571, 10-11=-237/530, 11-13=-370/894, 13-14=0/58, 13-15=-392/1018
BOT CHORD	21-22=-529/452, 20-21=-524/447, 19-20=-208/261, 18-19=-208/261, 17-18=-208/261, 16-17=-208/261, 15-16=-208/261

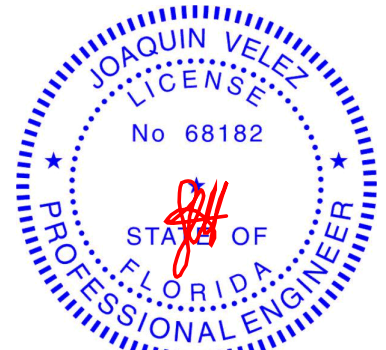

Joaquin Velez PE No.68182
MiTek USA, Inc. FL Cert 6634
6904 Parke East Blvd. Tampa FL 33610
Date:

April 7, 2022

WARNING - Verify design parameters and READ NOTES ON THIS AND INCLUDED MITEK REFERENCE PAGE MII-7473 rev. 5/19/2020 BEFORE USE.

Design valid for use only with MiTek® connectors. This design is based only upon parameters shown, and is for an individual building component, not a truss system. Before use, the building designer must verify the applicability of design parameters and properly incorporate this design into the overall building design. Bracing indicated is to prevent buckling of individual truss web and/or chord members only. Additional temporary and permanent bracing is always required for stability and to prevent collapse with possible personal injury and property damage. For general guidance regarding the fabrication, storage, delivery, erection and bracing of trusses and truss systems, see ANSITPI1 Quality Criteria, DSB-89 and BCSI Building Component Safety Information available from Truss Plate Institute, 2670 Crain Highway, Suite 203 Waldorf, MD 20601



6904 Parke East Blvd.
Tampa, FL 33610

Job 3039076	Truss D01	Truss Type Common Supported Gable	Qty 1	Ply 1	Job Reference (optional)	T27365420
----------------	--------------	--------------------------------------	----------	----------	--------------------------	-----------

Builders FirstSource (Groveland, FL), Groveland, FL - 34736,

Run: 8.53 S Dec 6 2021 Print: 8.530 S Dec 6 2021 MiTek Industries, Inc. Wed Apr 06 15:10:05
ID_u1yTfK3W804HT1iqIdcAUzTU7u-RfC?PsB70Hq3NSgPqnL8w3uITXbGKWrCDoi7J4zJC?f

Page: 1

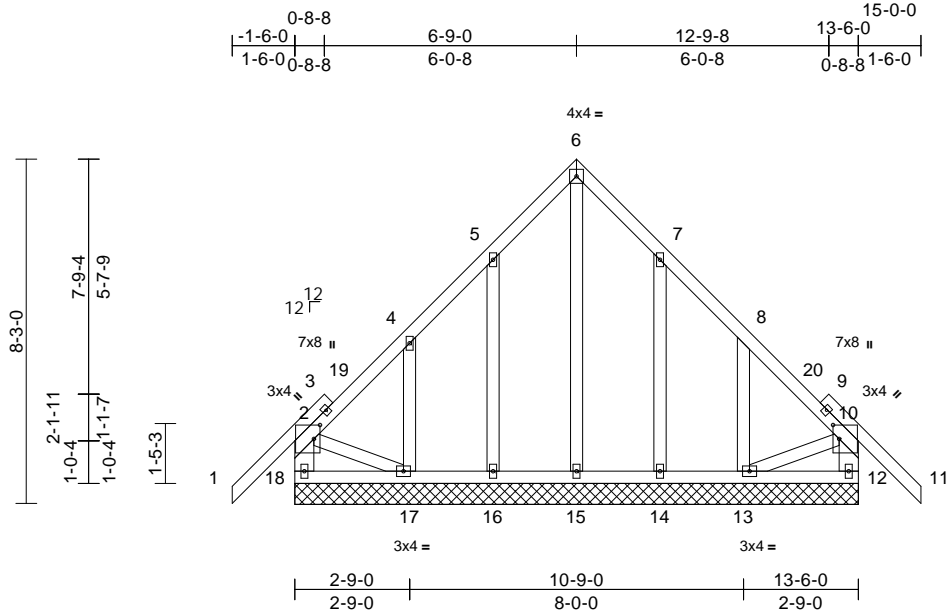

Scale = 1:55.2

Plate Offsets (X, Y): [2:0-4-0,0-1-12], [10:0-4-0,0-1-12]

Loading	(psf)	Spacing	2-0-0	CSI	DEFL	in	(loc)	l/defl	L/d	PLATES	GRIP	
TCLL (roof)	20.0	Plate Grip DOL	1.25	TC	0.51	Vert(LL)	n/a	-	n/a	999	MT20	244/190
TCDL	10.0	Lumber DOL	1.25	BC	0.08	Vert(CT)	n/a	-	n/a	999		
BCLL	0.0*	Rep Stress Incr	YES	WB	0.29	Horz(CT)	0.01	12	n/a	n/a		
BCDL	10.0	Code	FBC2020/TPI2014	Matrix-MS							Weight: 105 lb	FT = 20%

LUMBER
TOP CHORD 2x4 SP No.2
BOT CHORD 2x4 SP No.2
WEBS 2x6 SP No.2 *Except* 2-17,13-10:2x4 SP No.3
OTHERS 2x4 SP No.3

BRACING
TOP CHORD Structural wood sheathing directly applied or 6-0-0 oc purlins, except end verticals.
BOT CHORD Rigid ceiling directly applied or 6-0-0 oc bracing.

REACTIONS (lb/size)
12=248/13-6-0, 13=152/13-6-0,
14=164/13-6-0, 15=123/13-6-0,
16=164/13-6-0, 17=152/13-6-0,
18=248/13-6-0
Max Horiz 18=366 (LC 9)
Max Uplift 12=74 (LC 7), 13=-300 (LC 11),
14=-212 (LC 11), 16=-212 (LC 10),
17=-307 (LC 10), 18=-121 (LC 6)
Max Grav 12=248 (LC 1), 13=246 (LC 18),
14=213 (LC 18), 15=185 (LC 20),
16=214 (LC 17), 17=258 (LC 17),
18=283 (LC 18)

FORCES (lb) - Maximum Compression/Maximum Tension
TOP CHORD 2-18=-257/130, 1-2=0/69, 2-4=-229/176,
4-5=-136/120, 5-6=-137/294, 6-7=-137/294,
7-8=-95/75, 8-10=-206/119, 10-11=0/69,
10-12=-225/105
BOT CHORD 17-18=-304/317, 16-17=-171/472,
15-16=-171/472, 14-15=-171/472,
13-14=-171/472, 12-13=-36/173
WEBS 6-15=-274/62, 5-16=-184/293,
4-17=-212/264, 7-14=-184/293,
8-13=-212/264, 2-17=-187/327,
10-13=-187/327

NOTES

- Unbalanced roof live loads have been considered for this design.
- Wind: ASCE 7-16; Vult=140mph (3-second gust) Vasd=108mph; TCCL=4.2psf; BCDL=5.0psf; h=25ft; Cat. II; Exp C; Enclosed; MWFRS (envelope) exterior zone and C-C Corner(3E) -1-6-0 to 1-6-0, Exterior(2N) 1-6-0 to 3-9-0, Corner(3R) 3-9-0 to 9-9-0, Exterior(2N) 9-9-0 to 12-0-0, Corner(3E) 12-0-0 to 15-0-0 zone; end vertical left and right exposed; C-C for members and forces & MWFRS for reactions shown; Lumber DOL=1.60 plate grip DOL=1.60
- Truss designed for wind loads in the plane of the truss only. For studs exposed to wind (normal to the face), see Standard Industry Gable End Details as applicable, or consult qualified building designer as per ANSI/TPI 1.
- Building Designer / Project engineer responsible for verifying applied roof live load shown covers rain loading requirements specific to the use of this truss component.
- All plates are 2x4 MT20 unless otherwise indicated.
- Gable requires continuous bottom chord bearing.
- Truss to be fully sheathed from one face or securely braced against lateral movement (i.e. diagonal web).
- Gable studs spaced at 2-0-0 oc.
- This truss has been designed for a 10.0 psf bottom chord live load nonconcurrent with any other live loads.
- * This truss has been designed for a live load of 20.0psf on the bottom chord in all areas where a rectangle 3-06-00 tall by 2-00-00 wide will fit between the bottom chord and any other members.
- Provide mechanical connection (by others) of truss to bearing plate capable of withstanding 121 lb uplift at joint 18, 74 lb uplift at joint 12, 212 lb uplift at joint 16, 307 lb uplift at joint 17, 212 lb uplift at joint 14 and 300 lb uplift at joint 13.

LOAD CASE(S) Standard

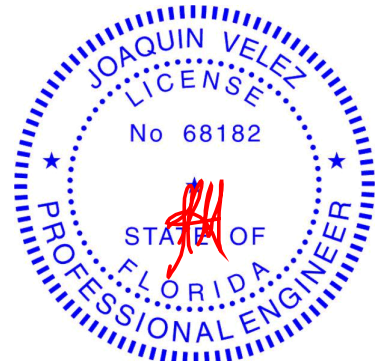

Joaquin Velez PE No.68182
MiTek USA, Inc. FL Cert 6634
6904 Parke East Blvd. Tampa FL 33610
Date:

April 7, 2022

WARNING - Verify design parameters and READ NOTES ON THIS AND INCLUDED MITEK REFERENCE PAGE MII-7473 rev. 5/19/2020 BEFORE USE.

Design valid for use only with MiTek® connectors. This design is based only upon parameters shown, and is for an individual building component, not a truss system. Before use, the building designer must verify the applicability of design parameters and properly incorporate this design into the overall building design. Bracing indicated is to prevent buckling of individual truss web and/or chord members only. Additional temporary and permanent bracing is always required for stability and to prevent collapse with possible personal injury and property damage. For general guidance regarding the fabrication, storage, delivery, erection and bracing of trusses and truss systems, see

ANSI/TPI1 Quality Criteria, DSB-89 and BCSI Building Component
Safety Information available from Truss Plate Institute, 2670 Crain Highway, Suite 203 Waldorf, MD 20601



6904 Parke East Blvd.
Tampa, FL 33610

Job 3039076	Truss D02	Truss Type Common	Qty 3	Ply 1	Job Reference (optional) T27365421
----------------	--------------	----------------------	----------	----------	---------------------------------------

Builders FirstSource (Groveland, FL), Groveland, FL - 34736,

Run: 8.53 S Dec 6 2021 Print: 8.530 S Dec 6 2021 MiTek Industries, Inc. Wed Apr 06 15:10:05
ID:RLCmJj3uk4yEsy95R6F3BezTU33-RfC?PsB70Hq3NSgPqnL8w3uITXbGKWrcDoi7J4zJC?f

Page: 1

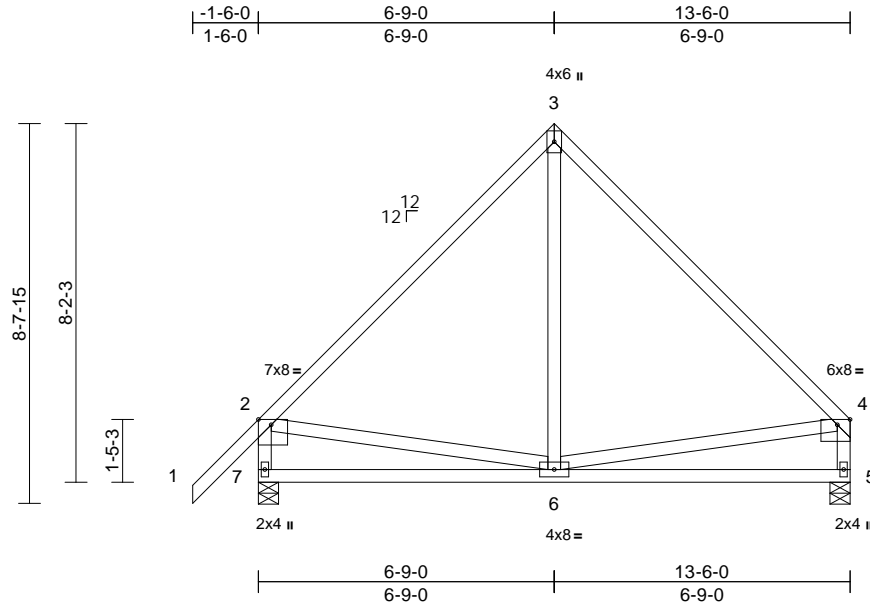

Scale = 1:52.6

Plate Offsets (X, Y): [2:0-3-8,Edge], [4:0-3-8,Edge]

Loading	(psf)	Spacing	2-0-0	CSI	DEFL	in	(loc)	l/defl	L/d	PLATES	GRIP	
TCLL (roof)	20.0	Plate Grip DOL	1.25	TC	0.77	Vert(LL)	-0.04	5-6	>999	360	MT20	244/190
TCDL	10.0	Lumber DOL	1.25	BC	0.39	Vert(CT)	-0.08	5-6	>999	240		
BCLL	0.0*	Rep Stress Incr	YES	WB	0.21	Horz(CT)	-0.01	5	n/a	n/a		
BCDL	10.0	Code	FBC2020/TPI2014	Matrix-MS		Wind(LL)	0.00	6	>999	240	Weight: 86 lb	FT = 20%

LUMBER

TOP CHORD 2x4 SP No.2 *Except* 3-4:2x4 SP M 31
 BOT CHORD 2x4 SP No.2
 WEBS 2x4 SP No.3 *Except* 7-2,5-4:2x4 SP No.2

BRACING

TOP CHORD Structural wood sheathing directly applied or 5-7-0 oc purlins, except end verticals.
 BOT CHORD Rigid ceiling directly applied or 8-4-12 oc bracing.

REACTIONS

(lb/size) 5=522/0-5-8, 7=633/0-5-8
 Max Horiz 7=367 (LC 9)
 Max Uplift 5=-203 (LC 10), 7=-252 (LC 10)

FORCES

(lb) - Maximum Compression/Maximum Tension
 TOP CHORD 1-2=0/70, 2-3=-525/258, 3-4=-509/245,
 2-7=-575/348, 4-5=-538/268
 BOT CHORD 6-7=-490/512, 5-6=-207/206
 WEBS 3-6=-26/262, 2-6=-241/441, 4-6=-180/312

NOTES

- 1) Unbalanced roof live loads have been considered for this design.
- 2) Wind: ASCE 7-16; Vult=140mph (3-second gust) Vasd=108mph; TCDL=4.2psf; BCDL=5.0psf; h=25ft; Cat. II; Exp C; Enclosed; MWFRS (envelope) exterior zone and C-C Exterior(2E) -1-6-0 to 1-6-0, Interior (1) 1-6-0 to 3-9-0, Exterior(2R) 3-9-0 to 9-9-0, Interior (1) 9-9-0 to 10-4-4, Exterior(2E) 10-4-4 to 13-4-4 zone; end vertical left and right exposed; C-C for members and forces & MWFRS for reactions shown; Lumber DOL=1.60 plate grip DOL=1.60
- 3) Building Designer / Project engineer responsible for verifying applied roof live load shown covers rain loading requirements specific to the use of this truss component.
- 4) This truss has been designed for a 10.0 psf bottom chord live load nonconcurrent with any other live loads.

- 5) * This truss has been designed for a live load of 20.0psf on the bottom chord in all areas where a rectangle 3-06-00 tall by 2-00-00 wide will fit between the bottom chord and any other members.
- 6) Provide mechanical connection (by others) of truss to bearing plate capable of withstanding 252 lb uplift at joint 7 and 203 lb uplift at joint 5.

LOAD CASE(S) Standard

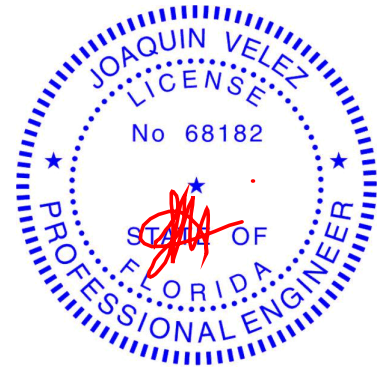

Joaquin Velez PE No.68182
 MiTek USA, Inc. FL Cert 6634
 6904 Parke East Blvd. Tampa FL 33610
 Date:

April 7, 2022

WARNING - Verify design parameters and READ NOTES ON THIS AND INCLUDED MITEK REFERENCE PAGE MII-7473 rev. 5/19/2020 BEFORE USE.

Design valid for use only with MiTek® connectors. This design is based only upon parameters shown, and is for an individual building component, not a truss system. Before use, the building designer must verify the applicability of design parameters and properly incorporate this design into the overall building design. Bracing indicated is to prevent buckling of individual truss web and/or chord members only. Additional temporary and permanent bracing is always required for stability and to prevent collapse with possible personal injury and property damage. For general guidance regarding the fabrication, storage, delivery, erection and bracing of trusses and truss systems, see ANSIT/TP1 Quality Criteria, DSB-89 and BCSI Building Component Safety Information available from Truss Plate Institute, 2670 Crain Highway, Suite 203 Waldorf, MD 20601



6904 Parke East Blvd.
 Tampa, FL 36610

Job 3039076	Truss D03	Truss Type Common Girder	Qty 2	Ply 2	Job Reference (optional) T27365422
----------------	--------------	-----------------------------	----------	----------	---------------------------------------

Builders FirstSource (Groveland, FL), Groveland, FL - 34736,

Run: 8:53 S Dec 6 2021 Print: 8:53 S Dec 6 2021 MiTek Industries, Inc. Wed Apr 06 15:10:05
ID:CtXEC9ThkeyY98556A72WzTS6b-RfC?PsB70Hq3NSgPqnL8w3uITxBGKWrCDoi7J4zJC7f

Page: 1

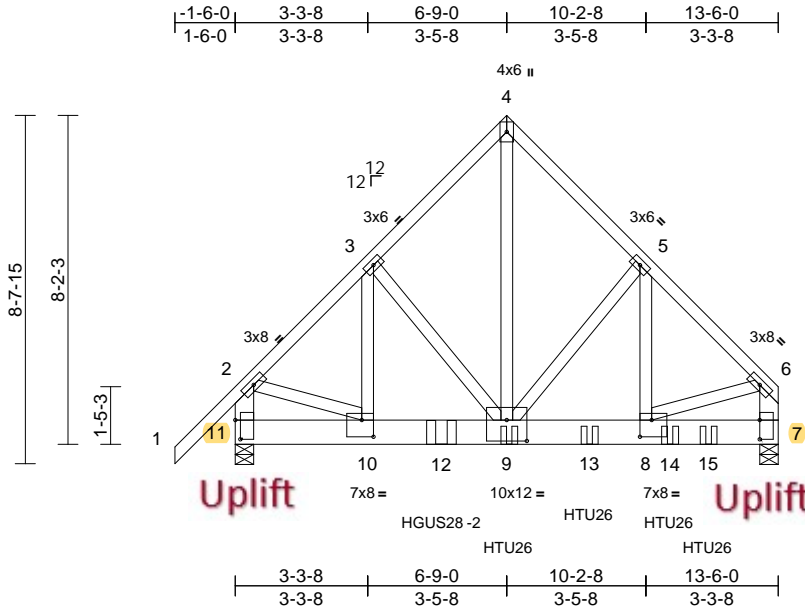

Scale = 1:57.3

Plate Offsets (X, Y): [5:0-0-0,0-0-0], [7:0-5-12,Edge], [8:0-3-8,0-5-0], [9:0-6-0,0-6-4], [10:0-3-8,0-5-0], [11:0-5-12,0-1-8]

Loading	(psf)	Spacing	2-0-0	CSI	DEFL	in	(loc)	l/defl	L/d	PLATES	GRIP	
TCLL (roof)	20.0	Plate Grip DOL	1.25	TC	0.36	Vert(LL)	-0.03	9-10	>999	360	MT20	244/190
TCDL	10.0	Lumber DOL	1.25	BC	0.25	Vert(CT)	-0.07	9-10	>999	240		
BCLL	0.0*	Rep Stress Incr	NO	WB	0.85	Horz(CT)	0.01	7	n/a	n/a		
BCDL	10.0	Code	FBC2020/TPI2014	Matrix-MS		Wind(LL)	0.08	9-10	>999	240	Weight: 247 lb	FT = 20%

LUMBER
TOP CHORD 2x4 SP No.2
BOT CHORD 2x8 SP 2400F 2.0E
WEBS 2x4 SP No.3 *Except* 11-2,7-6:2x6 SP No.2

BRACING
TOP CHORD Structural wood sheathing directly applied or 5-11-3 oc purlins, except end verticals.
BOT CHORD Rigid ceiling directly applied or 10-0-0 oc bracing.

REACTIONS (lb/size) 7=5207/0-5-8, 11=3555/0-5-8
Max Horiz 11=362 (LC 5)
Max Uplift 7=-3104 (LC 8), 11=-2902 (LC 8)
Max Grav 7=5445 (LC 15), 11=3938 (LC 15)

FORCES (lb) - Maximum Compression/Maximum Tension
TOP CHORD 1-2=0/73, 2-3=-4030/3079, 3-4=-3639/2669, 4-5=-3637/2669, 5-6=-4596/2743, 2-11=-3949/3003, 6-7=-4309/2572
BOT CHORD 10-11=-432/406, 9-10=-2213/2935, 8-9=-1842/3228, 7-8=-307/510
WEBS 2-10=-2059/2802, 6-8=-1685/2911, 3-10=-760/576, 3-9=-519/751, 4-9=-3583/4835, 5-9=-1295/395, 5-8=-235/1717

- NOTES**
- 2-ply truss to be connected together with 10d (0.131"x3") nails as follows:
Top chords connected as follows: 2x4 - 1 row at 0-9-0 oc, 2x6 - 2 rows staggered at 0-9-0 oc.
Bottom chords connected as follows: 2x8 - 2 rows staggered at 0-5-0 oc.
Web connected as follows: 2x4 - 1 row at 0-9-0 oc.
 - All loads are considered equally applied to all plies, except if noted as front (F) or back (B) face in the LOAD CASE(S) section. Ply to ply connections have been provided to distribute only loads noted as (F) or (B), unless otherwise indicated.

- Unbalanced roof live loads have been considered for this design.
- Wind: ASCE 7-16; Vult=140mph (3-second gust) Vasd=108mph; TC DL=4.2psf; BC DL=5.0psf; h=25ft; Cat. II; Exp C; Enclosed; MWFRS (envelope) exterior zone; end vertical left and right exposed; Lumber DOL=1.60 plate grip DOL=1.60
- Building Designer / Project engineer responsible for verifying applied roof live load shown covers rain loading requirements specific to the use of this truss component.
- This truss has been designed for a 10.0 psf bottom chord live load nonconcurrent with any other live loads.
- * This truss has been designed for a live load of 20.0psf on the bottom chord in all areas where a rectangle 3-06-00 tall by 2-00-00 wide will fit between the bottom chord and any other members.
- Provide mechanical connection (by others) of truss to bearing plate capable of withstanding 2902 lb uplift at joint 11 and 3104 lb uplift at joint 7.
- Use Simpson Strong-Tie HGUS28-2 (36-16d Girder, 12-16d Truss) or equivalent at 5-1-8 from the left end to connect truss(es) to back face of bottom chord.
- Use Simpson Strong-Tie HTU26 (20-10d Girder, 11-10dx1 1/2 Truss, Single Ply Girder) or equivalent spaced at 2-0-0 oc max. starting at 6-9-12 from the left end to 10-9-12 to connect truss(es) to back face of bottom chord.
- Use Simpson Strong-Tie HTU26 (20-10d Girder, 11-10dx1 1/2 Truss, Single Ply Girder) or equivalent at 11-9-4 from the left end to connect truss(es) to back face of bottom chord, skewed 0.0 deg.to the left, sloping 0.0 deg. down.
- Fill all nail holes where hanger is in contact with lumber.

LOAD CASE(S) Standard
1) Dead + Roof Live (balanced): Lumber Increase=1.25, Plate Increase=1.25
Uniform Loads (lb/ft)

Vert: 1-2=-60, 2-4=-60, 4-6=-60, 7-11=-20
Concentrated Loads (lb)
Vert: 9=-1357 (B), 12=-2194 (B), 13=-1355 (B), 14=-1355 (B), 15=-1355 (B)

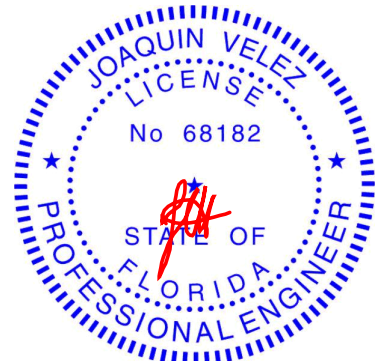

Joaquin Velez PE No.68182
MiTek USA, Inc. FL Cert 6634
6904 Parke East Blvd. Tampa FL 33610
Date:

April 7, 2022

WARNING - Verify design parameters and READ NOTES ON THIS AND INCLUDED MITEK REFERENCE PAGE MII-7473 rev. 5/19/2020 BEFORE USE.
Design valid for use only with MiTek® connectors. This design is based only upon parameters shown, and is for an individual building component, not a truss system. Before use, the building designer must verify the applicability of design parameters and properly incorporate this design into the overall building design. Bracing indicated is to prevent buckling of individual truss web and/or chord members only. Additional temporary and permanent bracing is always required for stability and to prevent collapse with possible personal injury and property damage. For general guidance regarding the fabrication, storage, delivery, erection and bracing of trusses and truss systems, see ANSITPI1 Quality Criteria, DSB-89 and BCSI Building Component Safety Information available from Truss Plate Institute, 2670 Crain Highway, Suite 203 Waldorf, MD 20601



Job 3039076	Truss D04	Truss Type Common Girder	Qty 1	Ply 1	Job Reference (optional)	T27365423
----------------	--------------	-----------------------------	----------	----------	--------------------------	-----------

Builders FirstSource (Groveland, FL), Groveland, FL - 34736,

Run: 8.53 S Dec 6 2021 Print: 8.530 S Dec 6 2021 MiTek Industries, Inc. Wed Apr 06 15:10:06
ID:A2BWM63SLHB2c36lyBiDExzTU?B-RfC?PsB70Hq3NSgPqnL8w3ulTXbGKwCdoi7J4zJC?f

Page: 1

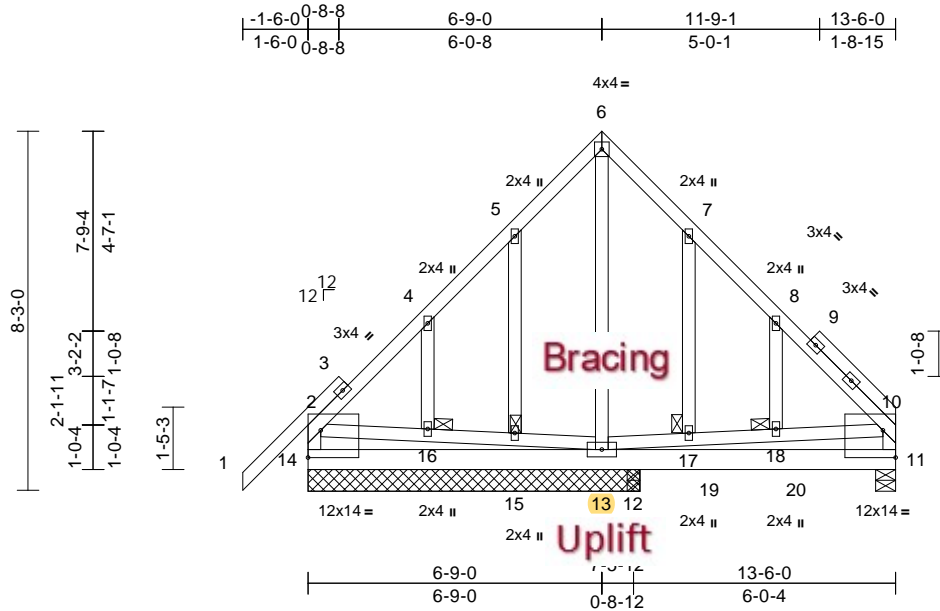

Scale = 1:52.9
Plate Offsets (X, Y): [11:Edge,0-7-8], [14:Edge,0-7-8]

Loading	(psf)	Spacing	2-0-0	CSI	DEFL	in	(loc)	l/defl	L/d	PLATES	GRIP	
TCLL (roof)	20.0	Plate Grip DOL	1.25	TC	0.87	Vert(LL)	-0.01	11-12	>999	360	MT20	244/190
TCDL	10.0	Lumber DOL	1.25	BC	0.30	Vert(CT)	-0.03	11-12	>999	240		
BCLL	0.0*	Rep Stress Incr	NO	WB	0.79	Horz(CT)	-0.01	11	n/a	n/a		
BCDL	10.0	Code	FBC2020/TPI2014	Matrix-MS		Wind(LL)	0.03	11-12	>999	240	Weight: 122 lb	FT = 20%

LUMBER
TOP CHORD 2x4 SP No.2
BOT CHORD 2x6 SP No.2
WEBS 2x4 SP No.3
OTHERS 2x4 SP No.3

BRACING
TOP CHORD Structural wood sheathing directly applied or 6-0-0 oc purlins, except end verticals.
BOT CHORD Rigid ceiling directly applied or 10-0-0 oc bracing.
JOINTS 1 Brace at Jt(s): 15, 16, 17, 18

REACTIONS (lb/size)
11=233/0-5-8, 12=490/0-3-8, 13=427/7-7-8, 14=261/7-7-8
Max Horiz 14=335 (LC 5)
Max Uplift 11=65 (LC 5), 12=470 (LC 5), 13=752 (LC 26)
Max Grav 11=267 (LC 20), 12=514 (LC 19), 13=474 (LC 16), 14=308 (LC 19)

FORCES (lb) - Maximum Compression/Maximum Tension
TOP CHORD 1-2=0/62, 2-4=-321/141, 4-5=-276/200, 5-6=-144/201, 6-7=-170/211, 7-8=-299/225, 8-10=-340/175, 2-14=-227/6, 10-11=-123/22
BOT CHORD 13-14=-507/531, 12-13=-440/353, 11-12=-440/353
WEBS 6-13=-408/363, 2-16=-472/739, 15-16=-474/741, 13-15=-496/771, 13-17=-586/841, 17-18=-563/811, 10-18=-560/807, 5-15=-128/171, 4-16=-15/21, 7-17=-130/171, 8-18=-22/29

NOTES
1) Unbalanced roof live loads have been considered for this design.

- Wind: ASCE 7-16; Vult=140mph (3-second gust) Vasd=108mph; TCCL=4.2psf; BCCL=5.0psf; h=25ft; Cat. II; Exp C; Enclosed; MWFRS (envelope) exterior zone; end vertical left and right exposed; Lumber DOL=1.60 plate grip DOL=1.60
- Truss designed for wind loads in the plane of the truss only. For studs exposed to wind (normal to the face), see Standard Industry Gable End Details as applicable, or consult qualified building designer as per ANSI/TPI 1.
- Building Designer / Project engineer responsible for verifying applied roof live load shown covers rain loading requirements specific to the use of this truss component.
- All plates are 2x4 MT20 unless otherwise indicated.
- Truss to be fully sheathed from one face or securely braced against lateral movement (i.e. diagonal web).
- Gable studs spaced at 2-0-0 oc.
- This truss has been designed for a 10.0 psf bottom chord live load nonconcurrent with any other live loads.
- * This truss has been designed for a live load of 20.0psf on the bottom chord in all areas where a rectangle 3-06-00 tall by 2-00-00 wide will fit between the bottom chord and any other members.
- Provide mechanical connection (by others) of truss to bearing plate capable of withstanding 65 lb uplift at joint 11, 752 lb uplift at joint 13 and 470 lb uplift at joint 12.
- Hanger(s) or other connection device(s) shall be provided sufficient to support concentrated load(s) 126 lb down and 133 lb up at 9-2-12, and 126 lb down and 133 lb up at 11-2-12 on bottom chord. The design/selection of such connection device(s) is the responsibility of others.
- In the LOAD CASE(S) section, loads applied to the face of the truss are noted as front (F) or back (B).

LOAD CASE(S) Standard
1) Dead + Roof Live (balanced): Lumber Increase=1.25, Plate Increase=1.25
Uniform Loads (lb/ft)

Vert: 1-2=-60, 2-6=-60, 6-10=-60, 11-14=-20
Concentrated Loads (lb)
Vert: 19=-126 (B), 20=-126 (B)

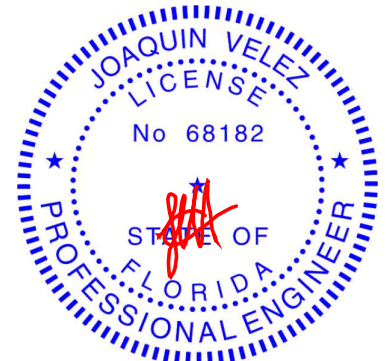

Joaquin Velez PE No.68182
MiTek USA, Inc. FL Cert 6634
6904 Parke East Blvd. Tampa FL 33610
Date:

April 7, 2022

WARNING - Verify design parameters and READ NOTES ON THIS AND INCLUDED MITEK REFERENCE PAGE MII-7473 rev. 5/19/2020 BEFORE USE.

Design valid for use only with MiTek® connectors. This design is based only upon parameters shown, and is for an individual building component, not a truss system. Before use, the building designer must verify the applicability of design parameters and properly incorporate this design into the overall building design. Bracing indicated is to prevent buckling of individual truss web and/or chord members only. Additional temporary and permanent bracing is always required for stability and to prevent collapse with possible personal injury and property damage. For general guidance regarding the fabrication, storage, delivery, erection and bracing of trusses and truss systems, see

ANSI/TPI1 Quality Criteria, DSB-89 and BCSI Building Component

Safety Information available from Truss Plate Institute, 2670 Crain Highway, Suite 203 Waldorf, MD 20601



6904 Parke East Blvd.
Tampa, FL 33610

Job 3039076	Truss D05	Truss Type Common Supported Gable	Qty 1	Ply 1	Job Reference (optional)	T27365424
----------------	--------------	--------------------------------------	----------	----------	--------------------------	-----------

Builders FirstSource (Groveland, FL), Groveland, FL - 34736,

Run: 8.53 S Dec 6 2021 Print: 8.530 S Dec 6 2021 MiTek Industries, Inc. Wed Apr 06 15:10:06
 ID:ReocYKOadTY3JBRDSSaKokzTTj-RC?PsB70Hq3NSgPqnL8w3uITXbGKwRCDoi7J4zJC?f

Page: 1

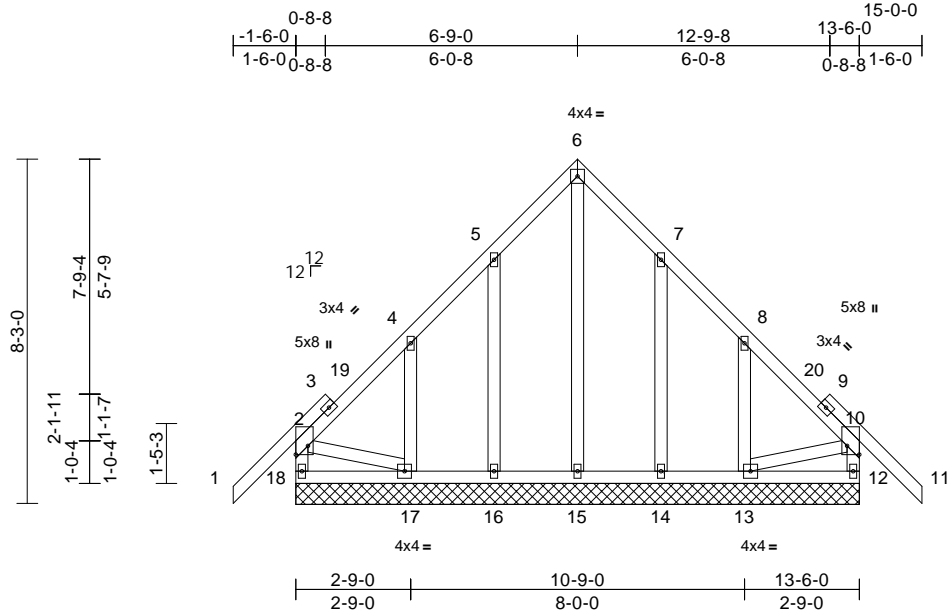

Scale = 1:55.2

Plate Offsets (X, Y): [2:Edge,0-3-8], [10:Edge,0-3-8]

Loading	(psf)	Spacing	2-0-0	CSI	DEFL	in	(loc)	l/defl	L/d	PLATES	GRIP	
TCLL (roof)	20.0	Plate Grip DOL	1.25	TC	0.41	Vert(LL)	n/a	-	n/a	999	MT20	244/190
TCDL	10.0	Lumber DOL	1.25	BC	0.08	Vert(CT)	n/a	-	n/a	999		
BCLL	0.0*	Rep Stress Incr	YES	WB	0.29	Horz(CT)	0.00	12	n/a	n/a		
BCDL	10.0	Code	FBC2020/TPI2014	Matrix-MS							Weight: 104 lb	FT = 20%

LUMBER

- TOP CHORD 2x4 SP No.2
- BOT CHORD 2x4 SP No.2
- WEBS 2x4 SP No.3
- OTHERS 2x4 SP No.3

BRACING

- TOP CHORD Structural wood sheathing directly applied or 6-0-0 oc purlins, except end verticals.
- BOT CHORD Rigid ceiling directly applied or 6-0-0 oc bracing.

REACTIONS

- (lb/size) 12=236/13-6-0, 13=164/13-6-0, 14=162/13-6-0, 15=131/13-6-0, 16=162/13-6-0, 17=164/13-6-0, 18=236/13-6-0
- Max Horiz 18=358 (LC 8)
- Max Uplift 12=74 (LC 7), 13=301 (LC 11), 14=210 (LC 11), 16=210 (LC 10), 17=306 (LC 10), 18=115 (LC 6)
- Max Grav 12=236 (LC 1), 13=255 (LC 18), 14=211 (LC 18), 15=193 (LC 20), 16=211 (LC 17), 17=263 (LC 17), 18=268 (LC 18)

FORCES

- (lb) - Maximum Compression/Maximum Tension
- TOP CHORD 2-18=-239/124, 1-2=0/62, 2-4=-229/177, 4-5=-130/119, 5-6=-129/300, 6-7=-129/300, 7-8=-93/81, 8-10=-208/135, 10-11=0/62, 10-12=-212/112
- BOT CHORD 17-18=-321/326, 16-17=-170/455, 15-16=-170/455, 14-15=-170/455, 13-14=-170/455, 12-13=-22/104
- WEBS 6-15=-283/50, 5-16=-178/293, 4-17=-237/265, 7-14=-178/293, 8-13=-237/265, 2-17=-184/373, 10-13=-177/373

NOTES

- Unbalanced roof live loads have been considered for this design.

- Wind: ASCE 7-16; Vult=140mph (3-second gust) Vasd=108mph; TCDL=4.2psf; BCDL=5.0psf; h=25ft; Cat. II; Exp C; Enclosed; MWFRS (envelope) exterior zone and C-C Corner(3E) -1-6-0 to 1-6-0, Exterior(2N) 1-6-0 to 3-9-0, Corner(3R) 3-9-0 to 9-9-0, Exterior(2N) 9-9-0 to 12-0-0, Corner(3E) 12-0-0 to 15-0-0 zone; end vertical left and right exposed;C-C for members and forces & MWFRS for reactions shown; Lumber DOL=1.60 plate grip DOL=1.60
- Truss designed for wind loads in the plane of the truss only. For studs exposed to wind (normal to the face), see Standard Industry Gable End Details as applicable, or consult qualified building designer as per ANSI/TPI 1.
- Building Designer / Project engineer responsible for verifying applied roof live load shown covers rain loading requirements specific to the use of this truss component.
- All plates are 2x4 MT20 unless otherwise indicated.
- Gable requires continuous bottom chord bearing.
- Truss to be fully sheathed from one face or securely braced against lateral movement (i.e. diagonal web).
- Gable studs spaced at 2-0-0 oc.
- This truss has been designed for a 10.0 psf bottom chord live load nonconcurrent with any other live loads.
- * This truss has been designed for a live load of 20.0psf on the bottom chord in all areas where a rectangle 3-06-00 tall by 2-00-00 wide will fit between the bottom chord and any other members.
- Provide mechanical connection (by others) of truss to bearing plate capable of withstanding 115 lb uplift at joint 18, 74 lb uplift at joint 12, 210 lb uplift at joint 16, 306 lb uplift at joint 17, 210 lb uplift at joint 14 and 301 lb uplift at joint 13.

LOAD CASE(S) Standard



Joaquin Velez PE No.68182
 MiTek USA, Inc. FL Cert 6634
 6904 Parke East Blvd. Tampa FL 33610
 Date:

April 7, 2022

WARNING - Verify design parameters and READ NOTES ON THIS AND INCLUDED MITEK REFERENCE PAGE MII-7473 rev. 5/19/2020 BEFORE USE.

Design valid for use only with MiTek® connectors. This design is based only upon parameters shown, and is for an individual building component, not a truss system. Before use, the building designer must verify the applicability of design parameters and properly incorporate this design into the overall building design. Bracing indicated is to prevent buckling of individual truss web and/or chord members only. Additional temporary and permanent bracing is always required for stability and to prevent collapse with possible personal injury and property damage. For general guidance regarding the fabrication, storage, delivery, erection and bracing of trusses and truss systems, see

ANSI/TPI1 Quality Criteria, DSB-89 and BCSI Building Component

Safety Information available from Truss Plate Institute, 2670 Crain Highway, Suite 203 Waldorf, MD 20601



6904 Parke East Blvd.
 Tampa, FL 33610

Job 3039076	Truss D06	Truss Type Common	Qty 1	Ply 1	Job Reference (optional) T27365425
----------------	--------------	----------------------	----------	----------	---------------------------------------

Builders FirstSource (Groveland, FL), Groveland, FL - 34736,

Run: 8.53 S Dec 6 2021 Print: 8.530 S Dec 6 2021 MiTek Industries, Inc. Wed Apr 06 15:10:06
ID:18DBBYBLJRkqAvjmcFaxRzTTqj-RfC?PsB70Hq3NSgPqnL8w3uITxBGKWrCDoi7J4zJC?f

Page: 1

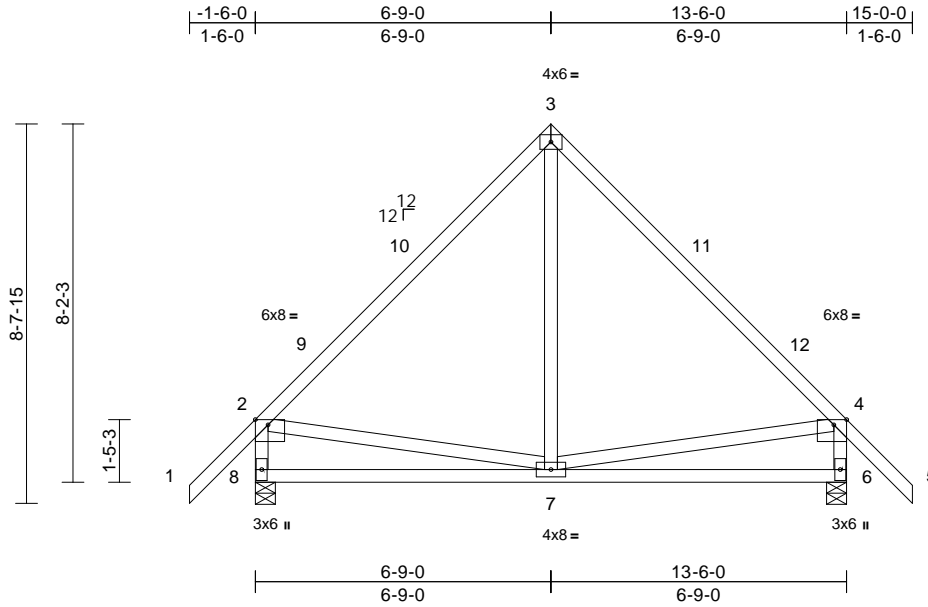

Scale = 1:52.6

Plate Offsets (X, Y): [2:0-3-8,Edge], [4:0-3-8,Edge]

Loading	(psf)	Spacing	2-0-0	CSI	DEFL	in	(loc)	l/defl	L/d	PLATES	GRIP	
TCLL (roof)	20.0	Plate Grip DOL	1.25	TC	0.98	Vert(LL)	-0.04	6-7	>999	360	MT20	244/190
TCDL	10.0	Lumber DOL	1.25	BC	0.39	Vert(CT)	-0.08	6-7	>999	240		
BCLL	0.0*	Rep Stress Incr	YES	WB	0.21	Horz(CT)	-0.01	6	n/a	n/a		
BCDL	10.0	Code	FBC2020/TPI2014	Matrix-MS		Wind(LL)	0.00	7	>999	240	Weight: 89 lb	FT = 20%

LUMBER

TOP CHORD 2x4 SP No.2
BOT CHORD 2x4 SP No.2
WEBS 2x4 SP No.3

BRACING

TOP CHORD Structural wood sheathing directly applied or 6-0-0 oc purlins, except end verticals.
BOT CHORD Rigid ceiling directly applied or 8-7-6 oc bracing.

REACTIONS

(lb/size) 6=627/0-5-8, 8=627/0-5-8
Max Horiz 8=-389 (LC 8)
Max Uplift 6=-251 (LC 11), 8=-251 (LC 10)

FORCES

(lb) - Maximum Compression/Maximum Tension
TOP CHORD 1-2=0/70, 2-3=-490/312, 3-4=-490/312, 4-5=0/70, 2-8=-568/458, 4-6=-568/458
BOT CHORD 7-8=-466/553, 6-7=-261/305
WEBS 3-7=-57/264, 2-7=-241/448, 4-7=-248/451

NOTES

- Unbalanced roof live loads have been considered for this design.
- Wind: ASCE 7-16; Vult=140mph (3-second gust) Vasd=108mph; TCDL=4.2psf; BCDL=5.0psf; h=25ft; Cat. II; Exp C; Enclosed; MWFRS (envelope) exterior zone and C-C Exterior(2E) -1-6-0 to 1-6-0, Interior (1) 1-6-0 to 3-9-0, Exterior(2R) 3-9-0 to 9-9-0, Interior (1) 9-9-0 to 12-0-0, Exterior(2E) 12-0-0 to 15-0-0 zone; end vertical left and right exposed; C-C for members and forces & MWFRS for reactions shown; Lumber DOL=1.60 plate grip DOL=1.60
- Building Designer / Project engineer responsible for verifying applied roof live load shown covers rain loading requirements specific to the use of this truss component.
- This truss has been designed for a 10.0 psf bottom chord live load nonconcurrent with any other live loads.

- * This truss has been designed for a live load of 20.0psf on the bottom chord in all areas where a rectangle 3-06-00 tall by 2-00-00 wide will fit between the bottom chord and any other members.
- Provide mechanical connection (by others) of truss to bearing plate capable of withstanding 251 lb uplift at joint 8 and 251 lb uplift at joint 6.

LOAD CASE(S) Standard

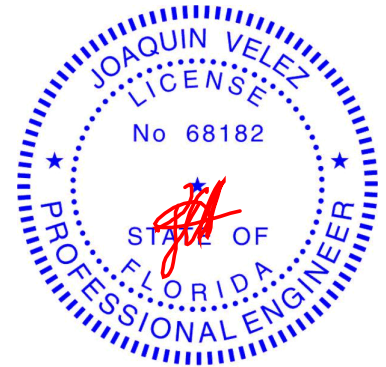

Joaquin Velez PE No.68182
MiTek USA, Inc. FL Cert 6634
6904 Parke East Blvd. Tampa FL 33610
Date:

April 7, 2022

WARNING - Verify design parameters and READ NOTES ON THIS AND INCLUDED MITEK REFERENCE PAGE MII-7473 rev. 5/19/2020 BEFORE USE.

Design valid for use only with MiTek® connectors. This design is based only upon parameters shown, and is for an individual building component, not a truss system. Before use, the building designer must verify the applicability of design parameters and properly incorporate this design into the overall building design. Bracing indicated is to prevent buckling of individual truss web and/or chord members only. Additional temporary and permanent bracing is always required for stability and to prevent collapse with possible personal injury and property damage. For general guidance regarding the fabrication, storage, delivery, erection and bracing of trusses and truss systems, see ANSIT/TP1 Quality Criteria, DSB-89 and BCSI Building Component Safety Information available from Truss Plate Institute, 2670 Crain Highway, Suite 203 Waldorf, MD 20601



6904 Parke East Blvd.
Tampa, FL 36610

Job 3039076	Truss EJ07	Truss Type Jack-Open	Qty 17	Ply 1	Job Reference (optional) T27365426
----------------	---------------	-------------------------	-----------	----------	---------------------------------------

Builders FirstSource (Groveland, FL), Groveland, FL - 34736,

Run: 8.53 S Dec 6 2021 Print: 8.530 S Dec 6 2021 MiTek Industries, Inc. Wed Apr 06 15:10:07
ID:O?rylplpGwLxet6I2b5WSezTU2m-RfC?PsB70Hq3NSgPqnL8w3ulTXbGKwRCDoi7J4zJC?f

Page: 1

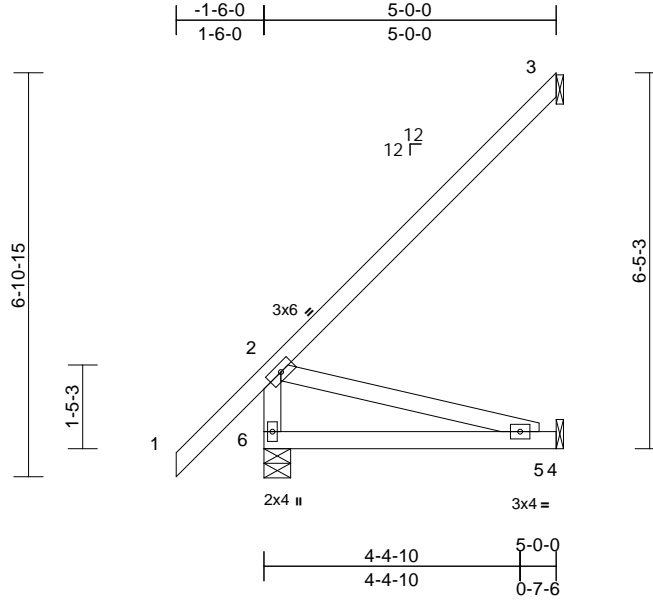

Loading	(psf)	Spacing	2-0-0	CSI	DEFL	in	(loc)	l/defl	L/d	PLATES	GRIP	
TCLL (roof)	20.0	Plate Grip DOL	1.25	TC	0.35	Vert(LL)	-0.03	5-6	>999	360	MT20	244/190
TCDL	10.0	Lumber DOL	1.25	BC	0.28	Vert(CT)	-0.06	5-6	>909	240		
BCLL	0.0*	Rep Stress Incr	YES	WB	0.14	Horz(CT)	-0.01	3	n/a	n/a		
BCDL	10.0	Code	FBC2020/TPI2014	Matrix-MP		Wind(LL)	0.01	5-6	>999	240	Weight: 30 lb	FT = 20%

LUMBER
TOP CHORD 2x4 SP M 31
BOT CHORD 2x4 SP No.2
WEBS 2x4 SP No.3

6) Provide mechanical connection (by others) of truss to bearing plate capable of withstanding 243 lb uplift at joint 3 and 69 lb uplift at joint 4.

LOAD CASE(S) Standard

BRACING
TOP CHORD Structural wood sheathing directly applied or 5-0-0 oc purlins, except end verticals.
BOT CHORD Rigid ceiling directly applied or 8-10-2 oc bracing.

REACTIONS (lb/size) 3=127/ Mechanical, 4=48/ Mechanical, 6=307/0-5-8
Max Horiz 6=349 (LC 10)
Max Uplift 3=243 (LC 10), 4=69 (LC 10)
Max Grav 3=178 (LC 17), 4=96 (LC 3), 6=307 (LC 1)

FORCES (lb) - Maximum Compression/Maximum Tension
TOP CHORD 2-6=-259/82, 1-2=0/70, 2-3=-200/236
BOT CHORD 5-6=-446/229, 4-5=0/0
WEBS 2-5=-237/462

- NOTES**
- 1) Wind: ASCE 7-16; Vult=140mph (3-second gust) Vasd=108mph; TC DL=4.2psf; BC DL=5.0psf; h=25ft; Cat. II; Exp C; Enclosed; MWFRS (envelope) exterior zone and C-C Exterior(2E) zone; end vertical left and right exposed; C-C for members and forces & MWFRS for reactions shown; Lumber DOL=1.60 plate grip DOL=1.60
 - 2) Building Designer / Project engineer responsible for verifying applied roof live load shown covers rain loading requirements specific to the use of this truss component.
 - 3) This truss has been designed for a 10.0 psf bottom chord live load nonconcurrent with any other live loads.
 - 4) * This truss has been designed for a live load of 20.0psf on the bottom chord in all areas where a rectangle 3-06-00 tall by 2-00-00 wide will fit between the bottom chord and any other members.
 - 5) Refer to girder(s) for truss to truss connections.

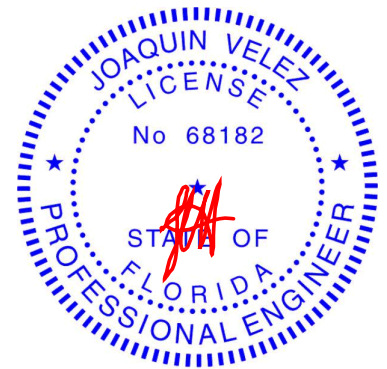

Joaquin Velez PE No.68182
MiTek USA, Inc. FL Cert 6634
6904 Parke East Blvd. Tampa FL 33610
Date:

April 7, 2022

WARNING - Verify design parameters and READ NOTES ON THIS AND INCLUDED MITEK REFERENCE PAGE MII-7473 rev. 5/19/2020 BEFORE USE.

Design valid for use only with MiTek® connectors. This design is based only upon parameters shown, and is for an individual building component, not a truss system. Before use, the building designer must verify the applicability of design parameters and properly incorporate this design into the overall building design. Bracing indicated is to prevent buckling of individual truss web and/or chord members only. Additional temporary and permanent bracing is always required for stability and to prevent collapse with possible personal injury and property damage. For general guidance regarding the fabrication, storage, delivery, erection and bracing of trusses and truss systems, see **ANSI/TPI1 Quality Criteria, DSB-89 and BCSI Building Component Safety Information** available from Truss Plate Institute, 2670 Crain Highway, Suite 203 Waldorf, MD 20601



6904 Parke East Blvd.
Tampa, FL 36610

Job 3039076	Truss F01	Truss Type Flat	Qty 4	Ply 1	Job Reference (optional) T27365427
----------------	--------------	--------------------	----------	----------	---------------------------------------

Builders FirstSource (Groveland, FL), Groveland, FL - 34736,

Run: 8.53 S Dec 6 2021 Print: 8.530 S Dec 6 2021 MiTek Industries, Inc. Wed Apr 06 15:10:07
ID:ulxV0iNnvRk3TVdHKWctp2zTmuY-RfC?PsB70Hq3NSgPqnL8w3uITXbGKWrCdoi7J4zJC?f

Page: 1

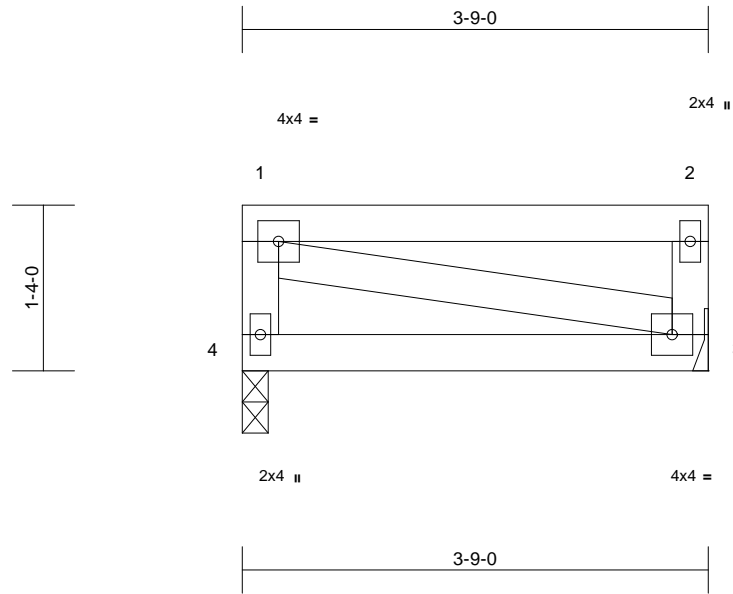

Scale = 1:18.5

Loading	(psf)	Spacing	2-0-0	CSI	DEFL	in	(loc)	l/defl	L/d	PLATES	GRIP	
TCLL (roof)	40.0	Plate Grip DOL	1.25	TC	0.41	Vert(LL)	-0.01	3-4	>999	360	MT20	244/190
TCDL	10.0	Lumber DOL	1.25	BC	0.14	Vert(CT)	-0.02	3-4	>999	240		
BCLL	0.0*	Rep Stress Incr	YES	WB	0.01	Horz(CT)	0.00	3	n/a	n/a		
BCDL	10.0	Code	FBC2020/TPI2014	Matrix-MP							Weight: 18 lb	FT = 20%

LUMBER

TOP CHORD 2x4 SP No.2
BOT CHORD 2x4 SP No.2
WEBS 2x4 SP No.3

- 8) Provide mechanical connection (by others) of truss to bearing plate capable of withstanding 82 lb uplift at joint 4 and 82 lb uplift at joint 3.

LOAD CASE(S) Standard

BRACING

TOP CHORD Structural wood sheathing directly applied or 3-9-0 oc purlins, except end verticals.
BOT CHORD Rigid ceiling directly applied or 10-0-0 oc bracing.

REACTIONS (lb/size) 3=208/ Mechanical, 4=208/0-2-8
Max Horiz 4=59 (LC 7)
Max Uplift 3=-82 (LC 7), 4=-82 (LC 6)

FORCES (lb) - Maximum Compression/Maximum Tension
TOP CHORD 1-4=-173/268, 1-2=-30/32, 2-3=-173/268
BOT CHORD 3-4=-51/46
WEBS 1-3=-31/31

NOTES

- 1) Wind: ASCE 7-16; Vult=140mph (3-second gust)
Vasd=108mph; TCDL=4.2psf; BCDL=5.0psf; h=25ft;
Cat. II; Exp C; Enclosed; MWFRS (envelope) exterior zone and C-C Corner (3) zone; end vertical left and right exposed; C-C for members and forces & MWFRS for reactions shown; Lumber DOL=1.60 plate grip DOL=1.60
- 2) Building Designer / Project engineer responsible for verifying applied roof live load shown covers rain loading requirements specific to the use of this truss component.
- 3) Provide adequate drainage to prevent water ponding.
- 4) This truss has been designed for a 10.0 psf bottom chord live load nonconcurrent with any other live loads.
- 5) * This truss has been designed for a live load of 20.0psf on the bottom chord in all areas where a rectangle 3-06-00 tall by 2-00-00 wide will fit between the bottom chord and any other members.
- 6) Refer to girder(s) for truss to truss connections.
- 7) Provide mechanical connection (by others) of truss to bearing plate at joint(s) 4.

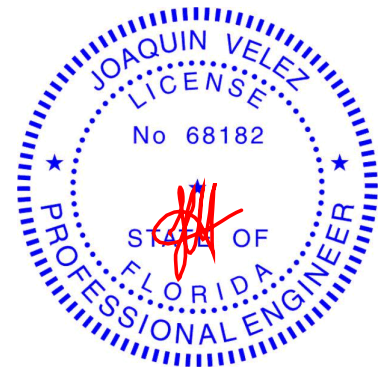

Joaquin Velez PE No.68182
MiTek USA, Inc. FL Cert 6634
6904 Parke East Blvd. Tampa FL 33610
Date:

April 7, 2022

WARNING - Verify design parameters and READ NOTES ON THIS AND INCLUDED MITEK REFERENCE PAGE MII-7473 rev. 5/19/2020 BEFORE USE.

Design valid for use only with MiTek® connectors. This design is based only upon parameters shown, and is for an individual building component, not a truss system. Before use, the building designer must verify the applicability of design parameters and properly incorporate this design into the overall building design. Bracing indicated is to prevent buckling of individual truss web and/or chord members only. Additional temporary and permanent bracing is always required for stability and to prevent collapse with possible personal injury and property damage. For general guidance regarding the fabrication, storage, delivery, erection and bracing of trusses and truss systems, see

ANSI/TPI1 Quality Criteria, DSB-89 and BCSI Building Component

Safety Information available from Truss Plate Institute, 2670 Crain Highway, Suite 203 Waldorf, MD 20601



6904 Parke East Blvd.
Tampa, FL 36610

Job 3039076	Truss F02	Truss Type Flat Girder	Qty 1	Ply 1	Job Reference (optional) T27365428
----------------	--------------	---------------------------	----------	----------	---------------------------------------

Builders FirstSource (Groveland, FL), Groveland, FL - 34736,

Run: 8.53 S Dec 6 2021 Print: 8.530 S Dec 6 2021 MiTek Industries, Inc. Wed Apr 06 15:10:07
ID:ulxV0iNnvRk3TVdHKWctp2zTmuY-RfC?PsB70Hq3NSgPqnl8w3uITXbGkWrCdoi7J4zJC?f

Page: 1

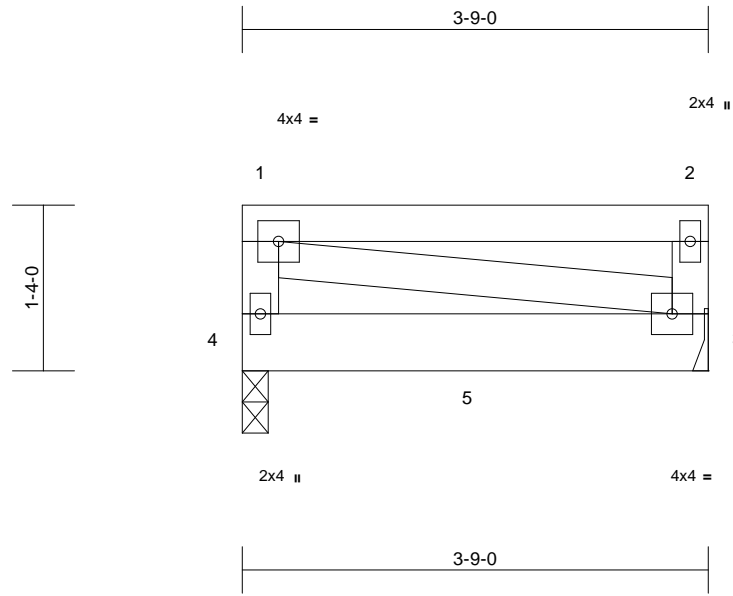

Loading	(psf)	Spacing	2-0-0	CSI	DEFL	in	(loc)	l/defl	L/d	PLATES	GRIP
TCLL (roof)	40.0	Plate Grip DOL	1.25	TC	0.75	Vert(LL)	0.02	3-4	>999	240	244/190
TCDL	10.0	Lumber DOL	1.25	BC	0.34	Vert(CT)	-0.02	3-4	>999	180	
BCLL	0.0*	Rep Stress Incr	NO	WB	0.01	Horz(CT)	0.00	3	n/a	n/a	
BCDL	10.0	Code	FBC2020/TPI2014	Matrix-MP						Weight: 21 lb	FT = 20%

LUMBER
TOP CHORD 2x4 SP No.2
BOT CHORD 2x6 SP No.2
WEBS 2x4 SP No.3

BRACING
TOP CHORD Structural wood sheathing directly applied or 3-9-0 oc purlins, except end verticals.
BOT CHORD Rigid ceiling directly applied or 10-0-0 oc bracing.

REACTIONS (lb/size) 3=501/ Mechanical, 4=510/0-2-8
Max Horiz 4=-54 (LC 4)
Max Uplift 3=-90 (LC 5), 4=-103 (LC 4)
Max Grav 3=501 (LC 1), 4=510 (LC 16)

FORCES (lb) - Maximum Compression/Maximum Tension
TOP CHORD 1-4=-339/0, 1-2=-20/15, 2-3=-339/0
BOT CHORD 3-4=-47/42
WEBS 1-3=-28/28

- NOTES**
- 1) Wind: ASCE 7-16; Vult=140mph (3-second gust)
Vasd=108mph; TCDL=4.2psf; BCDL=5.0psf; h=25ft;
Cat. II; Exp C; Enclosed; MWFRS (envelope) exterior zone; end vertical left and right exposed; Lumber DOL=1.60 plate grip DOL=1.60
 - 2) Building Designer / Project engineer responsible for verifying applied roof live load shown covers rain loading requirements specific to the use of this truss component.
 - 3) Provide adequate drainage to prevent water ponding.
 - 4) This truss has been designed for a 10.0 psf bottom chord live load nonconcurrent with any other live loads.
 - 5) * This truss has been designed for a live load of 20.0psf on the bottom chord in all areas where a rectangle 3-06-00 tall by 2-00-00 wide will fit between the bottom chord and any other members.
 - 6) Refer to girder(s) for truss to truss connections.
 - 7) Provide mechanical connection (by others) of truss to bearing plate at joint(s) 4.

- 8) Provide mechanical connection (by others) of truss to bearing plate capable of withstanding 103 lb uplift at joint 4 and 90 lb uplift at joint 3.
 - 9) Load case(s) 1 has/have been modified. Building designer must review loads to verify that they are correct for the intended use of this truss.
 - 10) Hanger(s) or other connection device(s) shall be provided sufficient to support concentrated load(s) 428 lb down and 364 lb up at 1-9-12 on bottom chord. The design/selection of such connection device(s) is the responsibility of others.
 - 11) In the LOAD CASE(S) section, loads applied to the face of the truss are noted as front (F) or back (B).
- LOAD CASE(S)** Standard
- 1) Dead + Roof Live (balanced): Lumber Increase=1.25, Plate Increase=1.25
Uniform Loads (lb/ft)
Vert: 1-2=-196, 3-4=-20
Concentrated Loads (lb)
Vert: 5=-264 (B)



Joaquin Velez PE No.68182
MiTek USA, Inc. FL Cert 6634
6904 Parke East Blvd. Tampa FL 33610
Date:

April 7, 2022

WARNING - Verify design parameters and READ NOTES ON THIS AND INCLUDED MITEK REFERENCE PAGE MII-7473 rev. 5/19/2020 BEFORE USE.

Design valid for use only with MiTek® connectors. This design is based only upon parameters shown, and is for an individual building component, not a truss system. Before use, the building designer must verify the applicability of design parameters and properly incorporate this design into the overall building design. Bracing indicated is to prevent buckling of individual truss web and/or chord members only. Additional temporary and permanent bracing is always required for stability and to prevent collapse with possible personal injury and property damage. For general guidance regarding the fabrication, storage, delivery, erection and bracing of trusses and truss systems, see

ANSI/TPI1 Quality Criteria, DSB-89 and BCSI Building Component

Safety Information available from Truss Plate Institute, 2670 Crain Highway, Suite 203 Waldorf, MD 20601



6904 Parke East Blvd.
Tampa, FL 33610

Job 3039076	Truss G01	Truss Type Jack-Closed	Qty 9	Ply 1	Job Reference (optional) T27365429
----------------	--------------	---------------------------	----------	----------	---------------------------------------

Builders FirstSource (Groveland, FL), Groveland, FL - 34736,

Run: 8.53 S Dec 6 2021 Print: 8.530 S Dec 6 2021 MiTek Industries, Inc. Wed Apr 06 15:10:07
ID:D65wul8PHdJsiF6mOFn04jzTTxC-RfC?PsB70Hq3NSgPqnL8w3uITXbGKWrCDoi7J4zJC7f

Page: 1

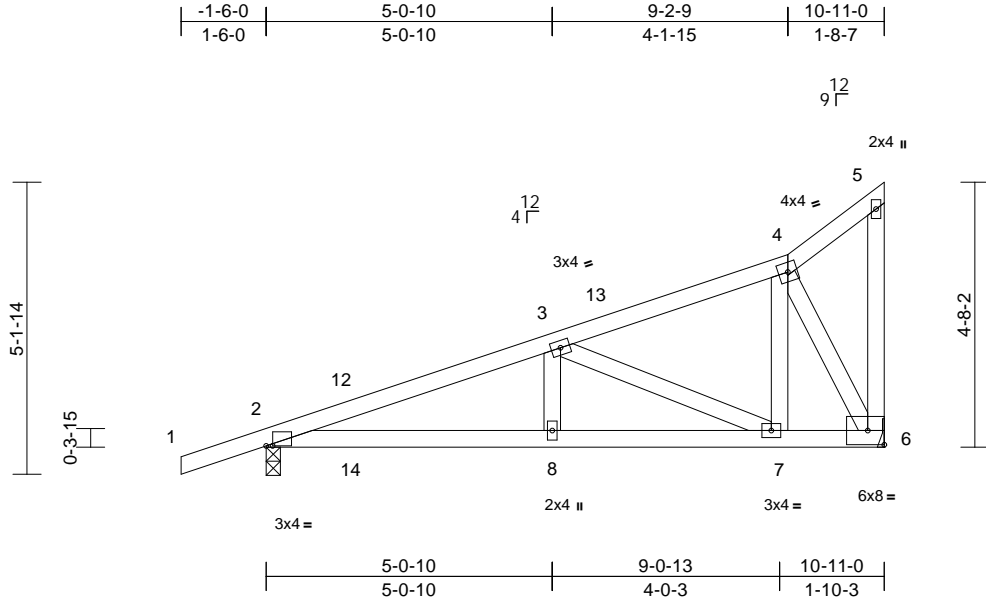

Scale = 1:40.7
Plate Offsets (X, Y): [2:0-1-6,Edge]

Loading	(psf)	Spacing	2-0-0	CSI	DEFL	in	(loc)	l/defl	L/d	PLATES	GRIP	
TCLL (roof)	20.0	Plate Grip DOL	1.25	TC	0.49	Vert(LL)	0.10	8-11	>999	240	MT20	244/190
TCDL	10.0	Lumber DOL	1.25	BC	0.34	Vert(CT)	-0.05	8-11	>999	240		
BCLL	0.0*	Rep Stress Incr	YES	WB	0.38	Horz(CT)	-0.02	6	n/a	n/a		
BCDL	10.0	Code	FBC2020/TPI2014	Matrix-AS							Weight: 60 lb	FT = 20%

LUMBER
TOP CHORD 2x4 SP No.2
BOT CHORD 2x4 SP No.2
WEBS 2x4 SP No.3

BRACING
TOP CHORD Structural wood sheathing directly applied, except end verticals.
BOT CHORD Rigid ceiling directly applied.

REACTIONS (lb/size) 2=527/0-3-0, 6=425/ Mechanical
Max Horiz 2=240 (LC 10)
Max Uplift 2=-466 (LC 6), 6=-305 (LC 6)

FORCES (lb) - Maximum Compression/Maximum Tension
TOP CHORD 1-2=0/28, 2-3=-803/1435, 3-4=-267/347, 4-5=-51/30, 5-6=-52/81
BOT CHORD 2-8=-1654/739, 7-8=-1654/739, 6-7=-448/198
WEBS 4-7=-802/293, 4-6=-438/985, 3-7=-573/1270, 3-8=-468/193

- 6) Provide mechanical connection (by others) of truss to bearing plate capable of withstanding 466 lb uplift at joint 2 and 305 lb uplift at joint 6.
- 7) This truss design requires that a minimum of 7/16" structural wood sheathing be applied directly to the top chord and 1/2" gypsum sheetrock be applied directly to the bottom chord.

LOAD CASE(S) Standard

- NOTES**
- 1) Wind: ASCE 7-16; Vult=140mph (3-second gust) Vasd=108mph; TC DL=4.2psf; BCDL=5.0psf; h=25ft; Cat. II; Exp C; Enclosed; MWFRS (envelope) exterior zone and C-C Exterior(2E) -1-6-0 to 1-6-0, Interior (1) 1-6-0 to 9-2-9, Exterior(2R) 9-2-9 to 10-9-4 zone; porch left and right exposed; C-C for members and forces & MWFRS for reactions shown; Lumber DOL=1.60 plate grip DOL=1.60
 - 2) Building Designer / Project engineer responsible for verifying applied roof live load shown covers rain loading requirements specific to the use of this truss component.
 - 3) This truss has been designed for a 10.0 psf bottom chord live load nonconcurrent with any other live loads.
 - 4) * This truss has been designed for a live load of 20.0psf on the bottom chord in all areas where a rectangle 3-06-00 tall by 2-00-00 wide will fit between the bottom chord and any other members.
 - 5) Refer to girder(s) for truss to truss connections.

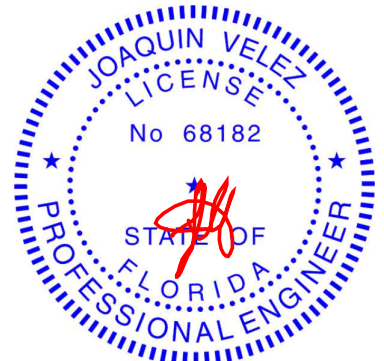

Joaquin Velez PE No.68182
MiTek USA, Inc. FL Cert 6634
6904 Parke East Blvd. Tampa FL 33610
Date:

April 7, 2022

<p>WARNING - Verify design parameters and READ NOTES ON THIS AND INCLUDED MITEK REFERENCE PAGE MII-7473 rev. 5/19/2020 BEFORE USE.</p> <p>Design valid for use only with MiTek® connectors. This design is based only upon parameters shown, and is for an individual building component, not a truss system. Before use, the building designer must verify the applicability of design parameters and properly incorporate this design into the overall building design. Bracing indicated is to prevent buckling of individual truss web and/or chord members only. Additional temporary and permanent bracing is always required for stability and to prevent collapse with possible personal injury and property damage. For general guidance regarding the fabrication, storage, delivery, erection and bracing of trusses and truss systems, see ANSI/TPI1 Quality Criteria, DSB-89 and BCSI Building Component Safety Information available from Truss Plate Institute, 2670 Crain Highway, Suite 203 Waldorf, MD 20601</p>	 6904 Parke East Blvd. Tampa, FL 36610
--	---

Job 3039076	Truss G02	Truss Type Roof Special	Qty 1	Ply 1	Job Reference (optional) T27365430
----------------	--------------	----------------------------	----------	----------	---------------------------------------

Builders FirstSource (Groveland, FL), Groveland, FL - 34736,

Run: 8.53 S Dec 6 2021 Print: 8.530 S Dec 6 2021 MiTek Industries, Inc. Wed Apr 06 15:10:07
ID:1X_ciAQdtiDbynMBFahPWzTTwr-RfC?PsB70Hq3NSgPqnL8w3ulTXbGKWrCDoi7J4zJC?f

Page: 1

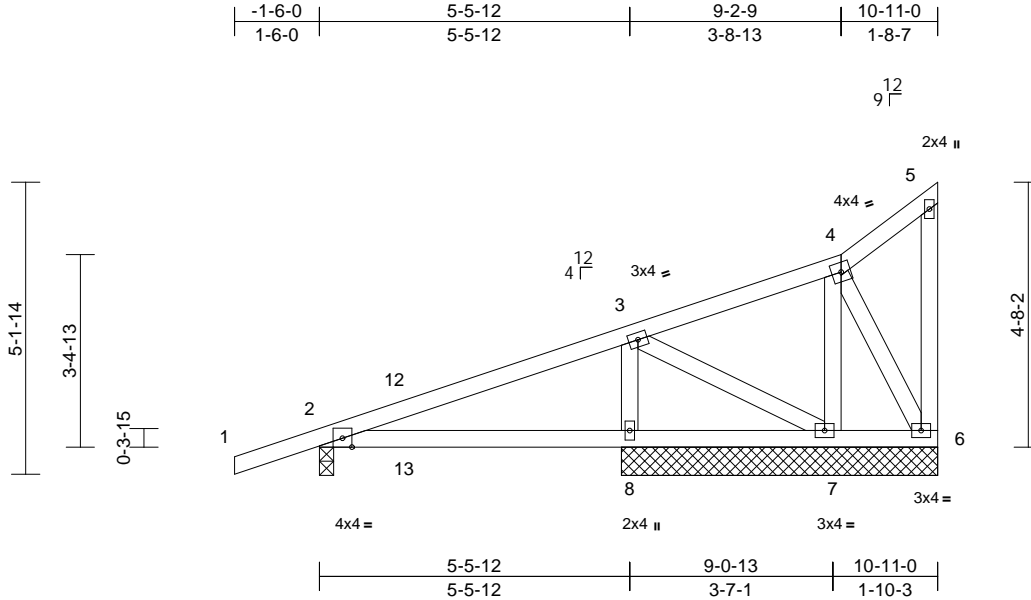

Loading	(psf)	Spacing	2-0-0	CSI	DEFL	in	(loc)	l/defl	L/d	PLATES	GRIP	
TCLL (roof)	20.0	Plate Grip DOL	1.25	TC	0.35	Vert(LL)	0.10	8-11	>679	240	MT20	244/190
TCDL	10.0	Lumber DOL	1.25	BC	0.40	Vert(CT)	-0.04	8-11	>999	240		
BCLL	0.0*	Rep Stress Incr	YES	WB	0.11	Horz(CT)	0.00	6	n/a	n/a		
BCDL	10.0	Code	FBC2020/TPI2014	Matrix-AS							Weight: 59 lb	FT = 20%

LUMBER
TOP CHORD 2x4 SP No.2
BOT CHORD 2x4 SP No.2
WEBS 2x4 SP No.3

BRACING
TOP CHORD Structural wood sheathing directly applied, except end verticals.
BOT CHORD Rigid ceiling directly applied.

REACTIONS (lb/size) 2=301/0-3-0, 6=87/5-7-0, 7=152/5-7-0, 8=412/5-7-0
Max Horiz 2=281 (LC 10)
Max Uplift 2=-270 (LC 6), 6=-122 (LC 10), 7=-49 (LC 10), 8=-317 (LC 6)

FORCES (lb) - Maximum Compression/Maximum Tension
TOP CHORD 1-2=0/28, 2-3=-131/51, 3-4=-111/37, 4-5=-69/31, 5-6=-53/110
BOT CHORD 2-8=-187/105, 7-8=-187/71, 6-7=-57/26
WEBS 4-7=-100/57, 4-6=-56/116, 3-8=-282/358, 3-7=-54/149

- Provide mechanical connection (by others) of truss to bearing plate capable of withstanding 270 lb uplift at joint 2, 49 lb uplift at joint 7, 122 lb uplift at joint 6 and 317 lb uplift at joint 8.
- This truss design requires that a minimum of 7/16" structural wood sheathing be applied directly to the top chord and 1/2" gypsum sheetrock be applied directly to the bottom chord.

LOAD CASE(S) Standard

NOTES

- Wind: ASCE 7-16; Vult=140mph (3-second gust) Vasd=108mph; TCDL=4.2psf; BCDL=5.0psf; h=25ft; Cat. II; Exp C; Enclosed; MWFRS (envelope) exterior zone and C-C Exterior(2E) -1-6-0 to 1-6-0, Interior (1) 1-6-0 to 9-2-9, Exterior(2E) 9-2-9 to 10-9-4 zone; porch left and right exposed; C-C for members and forces & MWFRS for reactions shown; Lumber DOL=1.60 plate grip DOL=1.60
- Building Designer / Project engineer responsible for verifying applied roof live load shown covers rain loading requirements specific to the use of this truss component.
- This truss has been designed for a 10.0 psf bottom chord live load nonconcurrent with any other live loads.
- * This truss has been designed for a live load of 20.0psf on the bottom chord in all areas where a rectangle 3-06-00 tall by 2-00-00 wide will fit between the bottom chord and any other members.

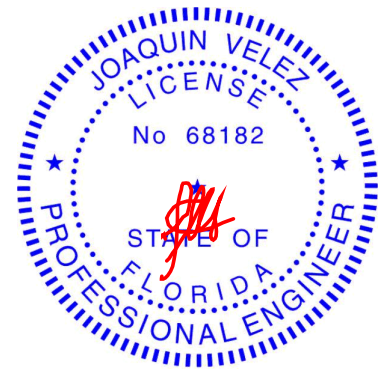

Joaquin Velez PE No.68182
MiTek USA, Inc. FL Cert 6634
6904 Parke East Blvd. Tampa FL 33610
Date:

April 7, 2022

WARNING - Verify design parameters and READ NOTES ON THIS AND INCLUDED MITEK REFERENCE PAGE MII-7473 rev. 5/19/2020 BEFORE USE.

Design valid for use only with MiTek® connectors. This design is based only upon parameters shown, and is for an individual building component, not a truss system. Before use, the building designer must verify the applicability of design parameters and properly incorporate this design into the overall building design. Bracing indicated is to prevent buckling of individual truss web and/or chord members only. Additional temporary and permanent bracing is always required for stability and to prevent collapse with possible personal injury and property damage. For general guidance regarding the fabrication, storage, delivery, erection and bracing of trusses and truss systems, see

ANSI/TPI1 Quality Criteria, DSB-89 and BCSI Building Component

Safety Information available from Truss Plate Institute, 2670 Crain Highway, Suite 203 Waldorf, MD 20601



6904 Parke East Blvd.
Tampa, FL 33610

Job 3039076	Truss G03	Truss Type Jack-Closed Structural Gable	Qty 1	Ply 1	Job Reference (optional)	T27365431
----------------	--------------	--	----------	----------	--------------------------	-----------

Builders FirstSource (Groveland, FL), Groveland, FL - 34736,

Run: 8.53 S Dec 6 2021 Print: 8.530 S Dec 6 2021 MiTek Industries, Inc. Wed Apr 06 15:10:08
ID:OQgoUdfJiLHXv6242r3eShzTTxq-RfC?PsB70Hq3NSgPqnL8w3uTXbGKWrCDoi7J4zJC7f

Page: 1

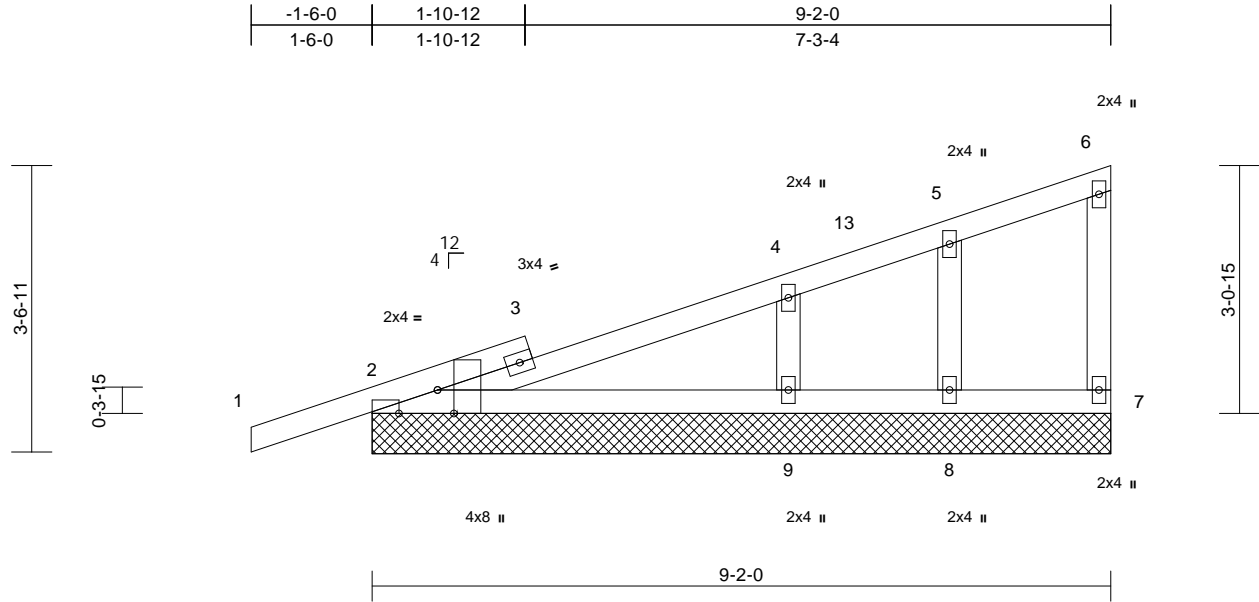

Loading	(psf)	Spacing	2-0-0	CSI	DEFL	in	(loc)	l/defl	L/d	PLATES	GRIP	
TCLL (roof)	20.0	Plate Grip DOL	1.25	TC	0.25	Vert(LL)	n/a	-	n/a	999	MT20	244/190
TCDL	10.0	Lumber DOL	1.25	BC	0.20	Vert(CT)	n/a	-	n/a	999		
BCLL	0.0*	Rep Stress Incr	YES	WB	0.10	Horz(CT)	0.00	7	n/a	n/a		
BCDL	10.0	Code	FBC2020/TPI2014	Matrix-AS							Weight: 40 lb	FT = 20%

LUMBER
TOP CHORD 2x4 SP No.2
BOT CHORD 2x4 SP No.2
WEBS 2x4 SP No.3
OTHERS 2x4 SP No.3

BRACING
TOP CHORD Structural wood sheathing directly applied, except end verticals.
BOT CHORD Rigid ceiling directly applied.

REACTIONS (lb/size) 2=277/9-2-0, 7=82/9-2-0, 8=54/9-2-0, 9=399/9-2-0, 10=277/9-2-0
Max Horiz 2=196 (LC 9), 10=196 (LC 9)
Max Uplift 2=-198 (LC 6), 7=-39 (LC 7), 8=-52 (LC 6), 9=-222 (LC 10), 10=-198 (LC 6)

FORCES (lb) - Maximum Compression/Maximum Tension
TOP CHORD 1-2=0/28, 2-4=-157/44, 4-5=-95/1, 5-6=-70/51, 6-7=-57/91
BOT CHORD 2-9=-70/74, 8-9=-70/74, 7-8=-70/74
WEBS 5-8=-63/168, 4-9=-266/335

NOTES
1) Wind: ASCE 7-16; Vult=140mph (3-second gust) Vasd=108mph; TCDL=4.2psf; BCDL=5.0psf; h=25ft; Cat. II; Exp C; Enclosed; MWFRS (envelope) exterior zone and C-C Exterior(2E) -1-6-0 to 1-8-13, Interior (1) 1-8-13 to 6-0-4, Exterior(2E) 6-0-4 to 9-0-4 zone; end vertical left and right exposed; C-C for members and forces & MWFRS for reactions shown; Lumber DOL=1.60 plate grip DOL=1.60
2) Truss designed for wind loads in the plane of the truss only. For studs exposed to wind (normal to the face), see Standard Industry Gable End Details as applicable, or consult qualified building designer as per ANSI/TPI 1.

- Building Designer / Project engineer responsible for verifying applied roof live load shown covers rain loading requirements specific to the use of this truss component.
- Gable requires continuous bottom chord bearing.
- Gable studs spaced at 2-0-0 oc.
- This truss has been designed for a 10.0 psf bottom chord live load nonconcurrent with any other live loads.
- * This truss has been designed for a live load of 20.0psf on the bottom chord in all areas where a rectangle 3-06-00 tall by 2-00-00 wide will fit between the bottom chord and any other members.
- Provide mechanical connection (by others) of truss to bearing plate capable of withstanding 198 lb uplift at joint 2, 39 lb uplift at joint 7, 52 lb uplift at joint 8, 222 lb uplift at joint 9 and 198 lb uplift at joint 2.
- This truss design requires that a minimum of 7/16" structural wood sheathing be applied directly to the top chord and 1/2" gypsum sheetrock be applied directly to the bottom chord.

LOAD CASE(S) Standard

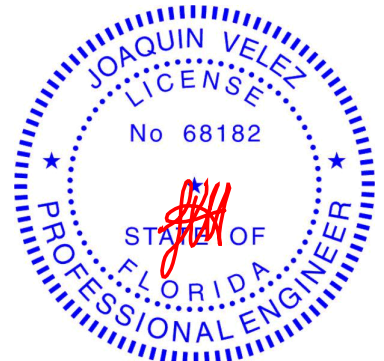

Joaquin Velez PE No.68182
MiTek USA, Inc. FL Cert 6634
6904 Parke East Blvd. Tampa FL 33610
Date:

April 7, 2022

Job 3039076	Truss G04	Truss Type Roof Special Supported Gable	Qty 2	Ply 1	Job Reference (optional)	T27365432
----------------	--------------	--	----------	----------	--------------------------	-----------

Builders FirstSource (Groveland, FL), Groveland, FL - 34736,

Run: 8.53 S Dec 6 2021 Print: 8.530 S Dec 6 2021 MiTek Industries, Inc. Wed Apr 06 15:10:08
ID:9fYzLQexPhaP5NUVAuFatzTU92-RfC?PsB70Hq3NSgPqnL8w3uITxBGKwRCDoi7J4zJC?f

Page: 1

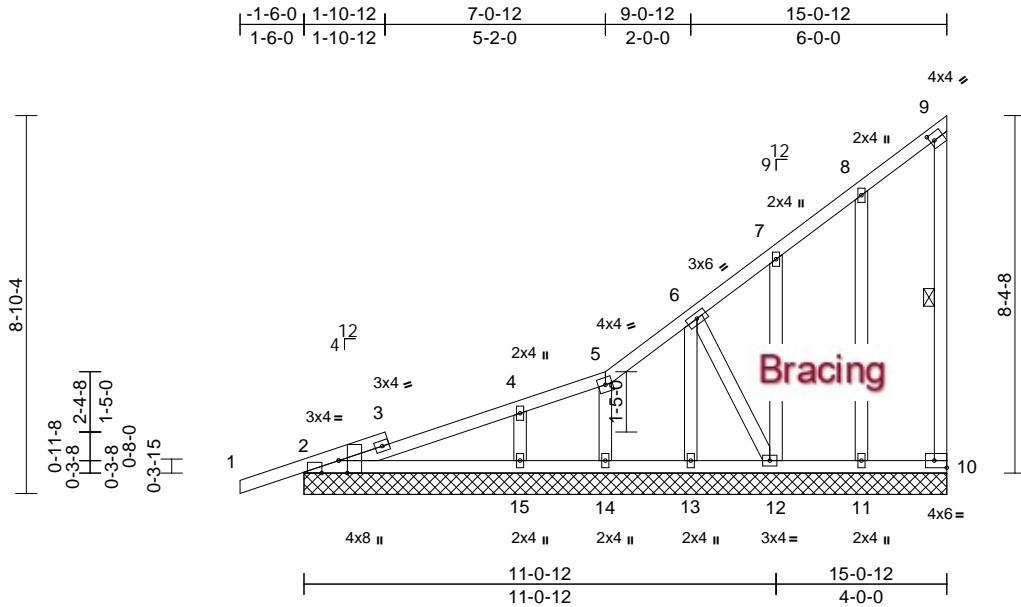

Scale = 1:54

Plate Offsets (X, Y): [2:0-3-8,Edge], [2:0-4-12,Edge], [9:0-1-2,0-2-0], [10:Edge,0-2-0]

Loading	(psf)	Spacing	2-0-0	CSI	DEFL	in	(loc)	l/defl	L/d	PLATES	GRIP	
TCLL (roof)	20.0	Plate Grip DOL	1.25	TC	0.60	Vert(LL)	n/a	-	n/a	999	MT20	244/190
TCDL	10.0	Lumber DOL	1.25	BC	0.42	Vert(CT)	n/a	-	n/a	999		
BCLL	0.0*	Rep Stress Incr	YES	WB	0.15	Horz(CT)	0.00	10	n/a	n/a		
BCDL	10.0	Code	FBC2020/TPI2014	Matrix-AS							Weight: 96 lb	FT = 20%

LUMBER	
TOP CHORD	2x4 SP No.2
BOT CHORD	2x4 SP No.2
WEBS	2x4 SP No.2 *Except* 12-6:2x4 SP No.3
OTHERS	2x4 SP No.3
BRACING	
TOP CHORD	Structural wood sheathing directly applied, except end verticals.
BOT CHORD	Rigid ceiling directly applied.
WEBS	1 Row at midpt 9-10
REACTIONS (lb/size)	
	2=270/15-0-12, 10=61/15-0-12, 11=168/15-0-12, 12=130/15-0-12, 13=219/15-0-12, 14=48/15-0-12, 15=387/15-0-12, 16=270/15-0-12
Max Horiz	2=498 (LC 9), 16=498 (LC 9)
Max Uplift	2=-228 (LC 6), 10=-125 (LC 9), 11=-168 (LC 10), 12=-274 (LC 10), 13=-15 (LC 6), 14=-25 (LC 6), 15=-219 (LC 6), 16=-228 (LC 6)
Max Grav	2=270 (LC 1), 10=121 (LC 6), 11=196 (LC 17), 12=230 (LC 17), 13=219 (LC 1), 14=88 (LC 18), 15=387 (LC 1), 16=270 (LC 1)
FORCES (lb) - Maximum Compression/Maximum Tension	
TOP CHORD	1-2=0/28, 2-4=-335/111, 4-5=-275/147, 5-6=-287/177, 6-7=-294/179, 7-8=-277/183, 8-9=-173/153, 9-10=-64/69
BOT CHORD	2-15=-204/152, 14-15=-204/152, 13-14=-204/152, 12-13=-204/152, 11-12=-198/244, 10-11=-198/244
WEBS	8-11=-189/165, 7-12=-144/297, 6-13=-165/24, 5-14=-90/93, 4-15=-249/313, 6-12=-80/238

- 1) Wind: ASCE 7-16; Vult=140mph (3-second gust) Vasd=108mph; TC DL=4.2psf; BCDL=5.0psf; h=25ft; Cat. II; Exp C; Enclosed; MWFRS (envelope) exterior zone and C-C Corner(3E) -1-6-0 to 1-8-13, Exterior(2N) 1-8-13 to 11-11-0, Corner(3E) 11-11-0 to 14-11-0 zone; end vertical left and right exposed; C-C for members and forces & MWFRS for reactions shown; Lumber DOL=1.60 plate grip DOL=1.60
- 2) Truss designed for wind loads in the plane of the truss only. For studs exposed to wind (normal to the face), see Standard Industry Gable End Details as applicable, or consult qualified building designer as per ANSI/TPI 1.
- 3) Building Designer / Project engineer responsible for verifying applied roof live load shown covers rain loading requirements specific to the use of this truss component.
- 4) Gable requires continuous bottom chord bearing.
- 5) Gable studs spaced at 2-0-0 oc.
- 6) This truss has been designed for a 10.0 psf bottom chord live load nonconcurrent with any other live loads.
- 7) * This truss has been designed for a live load of 20.0psf on the bottom chord in all areas where a rectangle 3-06-00 tall by 2-00-00 wide will fit between the bottom chord and any other members.
- 8) Provide mechanical connection (by others) of truss to bearing plate capable of withstanding 228 lb uplift at joint 2, 125 lb uplift at joint 10, 168 lb uplift at joint 11, 15 lb uplift at joint 13, 25 lb uplift at joint 14, 219 lb uplift at joint 15, 274 lb uplift at joint 12 and 228 lb uplift at joint 2.
- 9) This truss design requires that a minimum of 7/16" structural wood sheathing be applied directly to the top chord and 1/2" gypsum sheetrock be applied directly to the bottom chord.

LOAD CASE(S) Standard

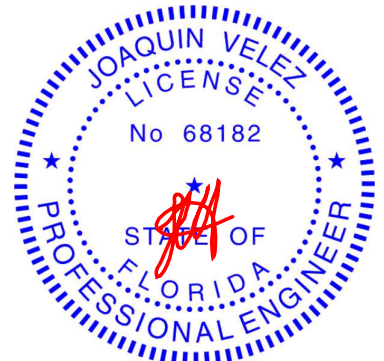

Joaquin Velez PE No.68182
MiTek USA, Inc. FL Cert 6634
6904 Parke East Blvd. Tampa FL 33610
Date: April 7, 2022

WARNING - Verify design parameters and READ NOTES ON THIS AND INCLUDED MITEK REFERENCE PAGE MII-7473 rev. 5/19/2020 BEFORE USE.
Design valid for use only with MiTek® connectors. This design is based only upon parameters shown, and is for an individual building component, not a truss system. Before use, the building designer must verify the applicability of design parameters and properly incorporate this design into the overall building design. Bracing indicated is to prevent buckling of individual truss web and/or chord members only. Additional temporary and permanent bracing is always required for stability and to prevent collapse with possible personal injury and property damage. For general guidance regarding the fabrication, storage, delivery, erection and bracing of trusses and truss systems, see **ANSI/TPI1 Quality Criteria, DSB-89 and BCSI Building Component Safety Information** available from Truss Plate Institute, 2670 Crain Highway, Suite 203 Waldorf, MD 20601



Job 3039076	Truss G05	Truss Type Jack-Closed	Qty 3	Ply 1	Job Reference (optional) T27365433
----------------	--------------	---------------------------	----------	----------	---------------------------------------

Builders FirstSource (Groveland, FL), Groveland, FL - 34736,

Run: 8.53 S Dec 6 2021 Print: 8.530 S Dec 6 2021 MiTek Industries, Inc. Wed Apr 06 15:10:08
ID:2iKwLXgp?sLbQJUWD4mAWIzTU8j-RfC?PsB70Hq3NSgPqnL8w3uITXbGKWrCDoi7J4zJC7f

Page: 1

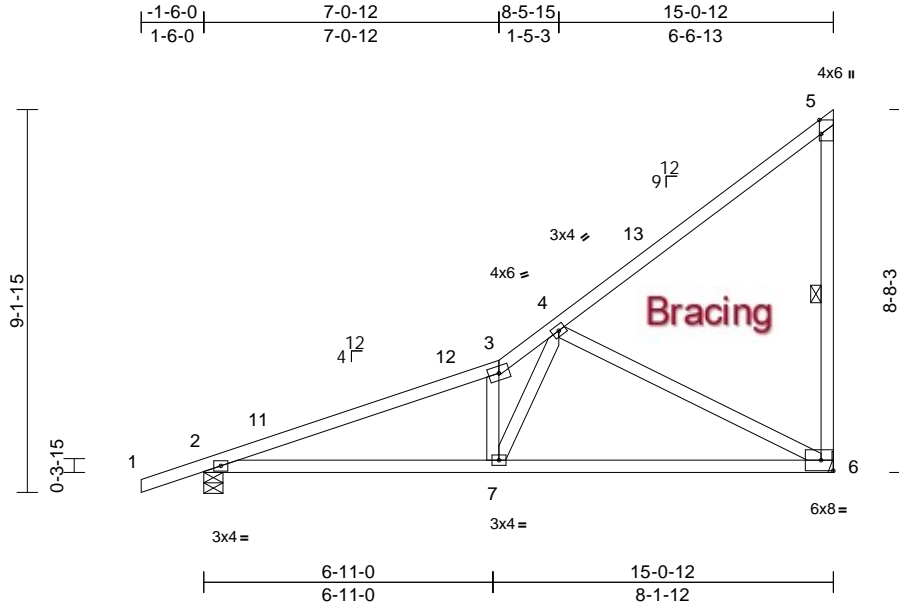

Scale = 1:55.1

Plate Offsets (X, Y): [5:0-4-0,Edge]

Loading	(psf)	Spacing	2-0-0	CSI	DEFL	in	(loc)	l/defl	L/d	PLATES	GRIP	
TCLL (roof)	20.0	Plate Grip DOL	1.25	TC	0.63	Vert(LL)	-0.11	6-7	>999	360	MT20	244/190
TCDL	10.0	Lumber DOL	1.25	BC	0.62	Vert(CT)	-0.23	6-7	>794	240		
BCLL	0.0*	Rep Stress Incr	YES	WB	0.79	Horz(CT)	0.02	6	n/a	n/a		
BCDL	10.0	Code	FBC2020/TPI2014	Matrix-AS		Wind(LL)	0.12	7-10	>999	240	Weight: 82 lb	FT = 20%

LUMBER

- TOP CHORD 2x4 SP No.2
- BOT CHORD 2x4 SP No.2
- WEBS 2x4 SP No.3 *Except* 5-6:2x4 SP No.2

BRACING

- TOP CHORD Structural wood sheathing directly applied, except end verticals.
- BOT CHORD Rigid ceiling directly applied.
- WEBS 1 Row at midpt 5-6

REACTIONS

- (lb/size) 2=691/0-5-8, 6=592/ Mechanical
- Max Horiz 2=519 (LC 9)
- Max Uplift 2=-364 (LC 6), 6=-264 (LC 7)
- Max Grav 2=691 (LC 1), 6=615 (LC 17)

FORCES

- (lb) - Maximum Compression/Maximum Tension
- TOP CHORD 1-2=0/28, 2-3=-1127/466, 3-4=-1379/634, 4-5=-305/168, 5-6=-229/216
- BOT CHORD 2-7=-505/1027, 6-7=-399/693
- WEBS 3-7=-623/518, 4-6=-769/685, 4-7=-531/932

NOTES

- 1) Wind: ASCE 7-16; Vult=140mph (3-second gust)
Vasd=108mph; TCDL=4.2psf; BCDL=5.0psf; h=25ft;
Cat. II; Exp C; Enclosed; MWFRS (envelope) exterior zone and C-C Exterior(2E) -1-6-0 to 1-6-0, Interior (1) 1-6-0 to 10-8-1, Exterior(2R) 10-8-1 to 14-11-0 zone; end vertical left and right exposed; C-C for members and forces & MWFRS for reactions shown; Lumber DOL=1.60 plate grip DOL=1.60
- 2) Building Designer / Project engineer responsible for verifying applied roof live load shown covers rain loading requirements specific to the use of this truss component.
- 3) This truss has been designed for a 10.0 psf bottom chord live load nonconcurrent with any other live loads.
- 4) * This truss has been designed for a live load of 20.0psf on the bottom chord in all areas where a rectangle 3-06-00 tall by 2-00-00 wide will fit between the bottom chord and any other members.

- 5) Refer to girder(s) for truss to truss connections.
- 6) Provide mechanical connection (by others) of truss to bearing plate capable of withstanding 364 lb uplift at joint 2 and 264 lb uplift at joint 6.
- 7) This truss design requires that a minimum of 7/16" structural wood sheathing be applied directly to the top chord and 1/2" gypsum sheetrock be applied directly to the bottom chord.

LOAD CASE(S) Standard

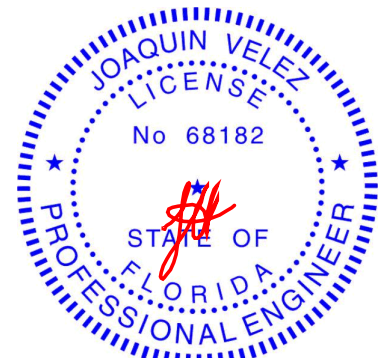

Joaquin Velez PE No.68182
MiTek USA, Inc. FL Cert 6634
6904 Parke East Blvd. Tampa FL 33610
Date:

April 7, 2022

WARNING - Verify design parameters and READ NOTES ON THIS AND INCLUDED MITEK REFERENCE PAGE MII-7473 rev. 5/19/2020 BEFORE USE.

Design valid for use only with MiTek® connectors. This design is based only upon parameters shown, and is for an individual building component, not a truss system. Before use, the building designer must verify the applicability of design parameters and properly incorporate this design into the overall building design. Bracing indicated is to prevent buckling of individual truss web and/or chord members only. Additional temporary and permanent bracing is always required for stability and to prevent collapse with possible personal injury and property damage. For general guidance regarding the fabrication, storage, delivery, erection and bracing of trusses and truss systems, see

ANSI/TPI1 Quality Criteria, DSB-89 and BCSI Building Component

Safety Information available from Truss Plate Institute, 2670 Crain Highway, Suite 203 Waldorf, MD 20601



6904 Parke East Blvd.
Tampa, FL 33610

Job 3039076	Truss K01	Truss Type Flat Girder	Qty 1	Ply 1	Job Reference (optional)	T27365434
----------------	--------------	---------------------------	----------	----------	--------------------------	-----------

Builders FirstSource (Groveland, FL), Groveland, FL - 34736,

Run: 8.53 S Dec 6 2021 Print: 8.530 S Dec 6 2021 MiTek Industries, Inc. Wed Apr 06 15:10:08
ID:eJxcwCQGZuYzoOdy2oAeqszTTvZ-RfC?PsB70Hq3NSgPqnL8w3ulTXbGKwRCDoi7J4zJC?f

Page: 1

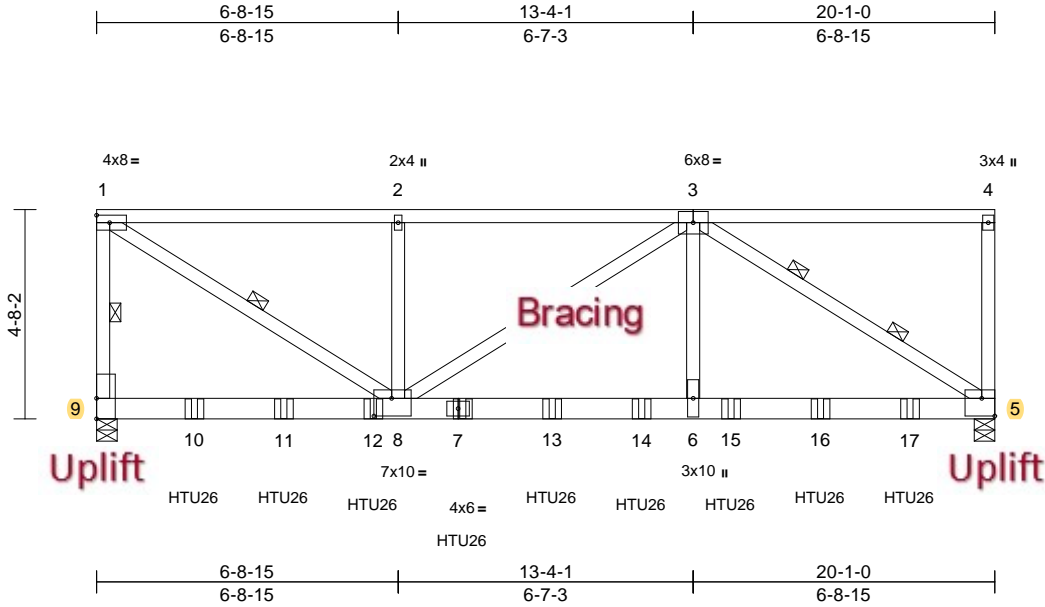

Scale = 1:51.5

Plate Offsets (X, Y): [5:Edge,0-4-12], [8:0-4-12,0-4-12]

Loading	(psf)	Spacing	2-0-0	CSI	DEFL	in	(loc)	l/defl	L/d	PLATES	GRIP	
TCLL (roof)	20.0	Plate Grip DOL	1.25	TC	0.84	Vert(LL)	-0.11	6-8	>999	360	MT20	244/190
TCDL	10.0	Lumber DOL	1.25	BC	0.48	Vert(CT)	-0.21	8-9	>999	240		
BCLL	0.0*	Rep Stress Incr	NO	WB	0.82	Horz(CT)	0.03	5	n/a	n/a		
BCDL	10.0	Code	FBC2020/TPI2014	Matrix-MS		Wind(LL)	0.20	6-8	>999	240	Weight: 133 lb	FT = 20%

LUMBER

TOP CHORD 2x4 SP No.1 *Except* 3-4:2x4 SP No.2
 BOT CHORD 2x6 SP M 26
 WEBS 2x4 SP No.3 *Except* 8-1,8-3,5-3:2x4 SP No.2

BRACING

TOP CHORD Structural wood sheathing directly applied or 2-9-14 oc purlins, except end verticals.
 BOT CHORD Rigid ceiling directly applied or 6-2-0 oc bracing.
 WEBS 1 Row at midpt 1-9, 1-8
 WEBS 2 Rows at 1/3 pts 3-5

REACTIONS (lb/size) 5=2637/0-5-8, 9=2588/0-5-8
 Max Uplift 5=-2021 (LC 4), 9=-1986 (LC 4)

FORCES (lb) - Maximum Compression/Maximum Tension

TOP CHORD 1-9=-2154/1662, 1-2=-3079/2352, 2-4=-3079/2352, 4-5=-177/153
 BOT CHORD 8-9=-41/52, 6-8=-2361/3091, 5-6=-2361/3091
 WEBS 1-8=-2758/3615, 2-8=-411/368, 3-8=-14/11, 3-6=-1154/1570, 3-5=-3628/2769

NOTES

- 1) Wind: ASCE 7-16; Vult=140mph (3-second gust)
 Vasd=108mph; TC DL=4.2psf; BCDL=5.0psf; h=25ft;
 Cat. II; Exp C; Enclosed; MWFRS (envelope) exterior zone; porch left and right exposed; Lumber DOL=1.60 plate grip DOL=1.60
- 2) Building Designer / Project engineer responsible for verifying applied roof live load shown covers rain loading requirements specific to the use of this truss component.
- 3) Provide adequate drainage to prevent water ponding.
- 4) This truss has been designed for a 10.0 psf bottom chord live load nonconcurrent with any other live loads.
- 5) * This truss has been designed for a live load of 20.0psf on the bottom chord in all areas where a rectangle 3-06-00 tall by 2-00-00 wide will fit between the bottom chord and any other members.

- 6) Provide mechanical connection (by others) of truss to bearing plate capable of withstanding 1986 lb uplift at joint 9 and 2021 lb uplift at joint 5.
 - 7) Use Simpson Strong-Tie HTU26 (20-10d Girder, 11-10dx1 1/2 Truss, Single Ply Girder) or equivalent spaced at 2-0-0 oc max. starting at 2-2-4 from the left end to 18-2-4 to connect truss(es) to back face of bottom chord.
 - 8) Fill all nail holes where hanger is in contact with lumber.
 - 9) In the LOAD CASE(S) section, loads applied to the face of the truss are noted as front (F) or back (B).
- LOAD CASE(S) Standard
- 1) Dead + Roof Live (balanced): Lumber Increase=1.25, Plate Increase=1.25
 Uniform Loads (lb/ft)
 Vert: 1-4=-60, 5-9=-20
 Concentrated Loads (lb)
 Vert: 7=-405 (B), 10=-405 (B), 11=-405 (B), 12=-405 (B), 13=-405 (B), 14=-405 (B), 15=-405 (B), 16=-405 (B), 17=-405 (B)

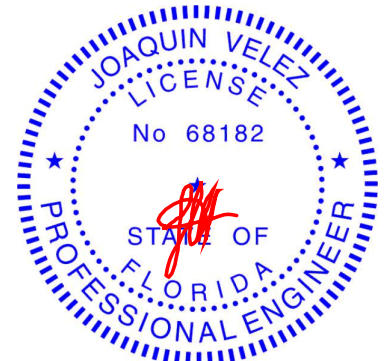

Joaquin Velez PE No.68182
 MiTek USA, Inc. FL Cert 6634
 6904 Parke East Blvd. Tampa FL 33610
 Date:

April 7, 2022

WARNING - Verify design parameters and READ NOTES ON THIS AND INCLUDED MITEK REFERENCE PAGE MII-7473 rev. 5/19/2020 BEFORE USE.

Design valid for use only with MiTek® connectors. This design is based only upon parameters shown, and is for an individual building component, not a truss system. Before use, the building designer must verify the applicability of design parameters and properly incorporate this design into the overall building design. Bracing indicated is to prevent buckling of individual truss web and/or chord members only. Additional temporary and permanent bracing is always required for stability and to prevent collapse with possible personal injury and property damage. For general guidance regarding the fabrication, storage, delivery, erection and bracing of trusses and truss systems, see

ANSI/TPI1 Quality Criteria, DSB-89 and BCSI Building Component

Safety Information available from Truss Plate Institute, 2670 Crain Highway, Suite 203 Waldorf, MD 20601



6904 Parke East Blvd.
 Tampa, FL 33610

Job 3039076	Truss K02	Truss Type Flat Girder	Qty 1	Ply 1	Job Reference (optional) T27365435
----------------	--------------	---------------------------	----------	----------	---------------------------------------

Builders FirstSource (Groveland, FL), Groveland, FL - 34736,

Run: 8.53 S Dec 6 2021 Print: 8.530 S Dec 6 2021 MiTek Industries, Inc. Wed Apr 06 15:10:09
ID:UM_t9xyg7IIDlbhztYvyODzTTtc-RfC?PsB70Hq3NSgPqnL8w3uITXbGKWrCDoi7J4zJC?f

Page: 1

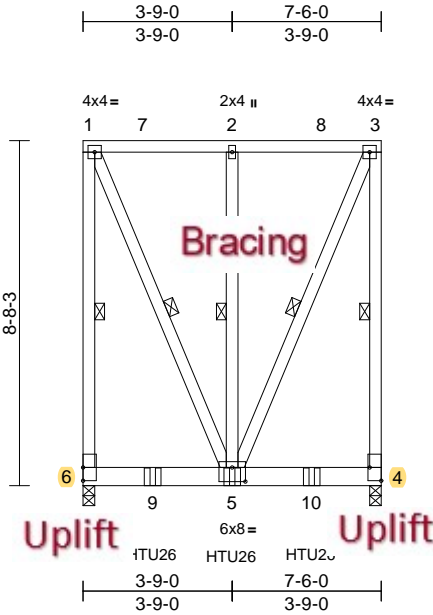

Scale = 1:58

Plate Offsets (X, Y): [4:Edge,0-3-8], [5:0-4-0,0-4-4]

Loading	(psf)	Spacing	2-0-0	CSI	DEFL	in	(loc)	l/defl	L/d	PLATES	GRIP	
TCLL (roof)	20.0	Plate Grip DOL	1.25	TC	0.97	Vert(LL)	-0.02	5-6	>999	360	MT20	244/190
TCDL	10.0	Lumber DOL	1.25	BC	0.43	Vert(CT)	-0.03	5-6	>999	240		
BCLL	0.0*	Rep Stress Incr	NO	WB	0.32	Horz(CT)	0.00	4	n/a	n/a		
BCDL	10.0	Code	FBC2020/TPI2014	Matrix-MS		Wind(LL)	0.03	5-6	>999	240	Weight: 90 lb	FT = 20%

LUMBER

TOP CHORD 2x4 SP No.2
BOT CHORD 2x6 SP No.2
WEBS 2x4 SP No.3

BRACING

TOP CHORD Structural wood sheathing directly applied or 6-0-0 oc purlins, except end verticals.
BOT CHORD Rigid ceiling directly applied or 10-0-0 oc bracing.

WEBS 1 Row at midpt 1-6, 3-4, 3-5, 2-5, 1-5

REACTIONS

(lb/size) 4=1147/0-3-8, 6=1147/0-3-8
Max Horiz 6=470 (LC 7)
Max Uplift 4=834 (LC 5), 6=834 (LC 4)
Max Grav 4=1234 (LC 15), 6=1234 (LC 16)

FORCES

(lb) - Maximum Compression/Maximum Tension
TOP CHORD 1-6=-939/699, 1-2=-365/181, 2-3=-365/181, 3-4=-939/699
BOT CHORD 5-6=-406/365, 4-5=-178/138
WEBS 3-5=-695/991, 2-5=-244/225, 1-5=-695/991

NOTES

- 1) Wind: ASCE 7-16; Vult=140mph (3-second gust)
Vasd=108mph; TCDL=4.2psf; BCDL=5.0psf; h=25ft;
Cat. II; Exp C; Enclosed; MWFRS (envelope) exterior zone; end vertical left and right exposed; Lumber DOL=1.60 plate grip DOL=1.60
- 2) Building Designer / Project engineer responsible for verifying applied roof live load shown covers rain loading requirements specific to the use of this truss component.
- 3) Provide adequate drainage to prevent water ponding.
- 4) This truss has been designed for a 10.0 psf bottom chord live load nonconcurrent with any other live loads.
- 5) * This truss has been designed for a live load of 20.0psf on the bottom chord in all areas where a rectangle 3-06-00 tall by 2-00-00 wide will fit between the bottom chord and any other members.

- 6) Provide mechanical connection (by others) of truss to bearing plate capable of withstanding 834 lb uplift at joint 6 and 834 lb uplift at joint 4.
- 7) Use Simpson Strong-Tie HTU26 (20-10d Girder, 11-10dx1 1/2 Truss, Single Ply Girder) or equivalent spaced at 2-0-0 oc max. starting at 1-9-0 from the left end to 5-9-0 to connect truss(es) to front face of bottom chord.
- 8) Fill all nail holes where hanger is in contact with lumber.
- 9) In the LOAD CASE(S) section, loads applied to the face of the truss are noted as front (F) or back (B).

LOAD CASE(S) Standard

- 1) Dead + Roof Live (balanced): Lumber Increase=1.25, Plate Increase=1.25
Uniform Loads (lb/ft)
Vert: 1-3=-60, 4-6=-20
Concentrated Loads (lb)
Vert: 5=-572 (F), 9=-572 (F), 10=-572 (F)

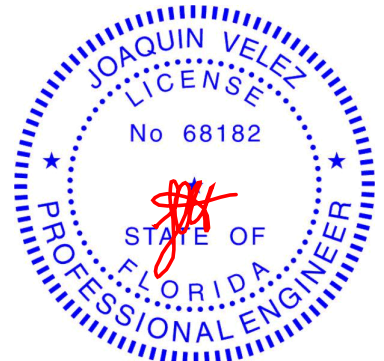

Joaquin Velez PE No.68182
MiTek USA, Inc. FL Cert 6634
6904 Parke East Blvd. Tampa FL 33610
Date:

April 7, 2022

WARNING - Verify design parameters and READ NOTES ON THIS AND INCLUDED MITEK REFERENCE PAGE MII-7473 rev. 5/19/2020 BEFORE USE.

Design valid for use only with MiTek® connectors. This design is based only upon parameters shown, and is for an individual building component, not a truss system. Before use, the building designer must verify the applicability of design parameters and properly incorporate this design into the overall building design. Bracing indicated is to prevent buckling of individual truss web and/or chord members only. Additional temporary and permanent bracing is always required for stability and to prevent collapse with possible personal injury and property damage. For general guidance regarding the fabrication, storage, delivery, erection and bracing of trusses and truss systems, see

ANSI/TPI1 Quality Criteria, DSB-89 and BCSI Building Component

Safety Information available from Truss Plate Institute, 2670 Crain Highway, Suite 203 Waldorf, MD 20601



6904 Parke East Blvd.
Tampa, FL 33610

Job 3039076	Truss M01	Truss Type Monopitch	Qty 12	Ply 1	Job Reference (optional) T27365436
----------------	--------------	-------------------------	-----------	----------	---------------------------------------

Builders FirstSource (Groveland, FL), Groveland, FL - 34736,

Run: 8.53 S Dec 6 2021 Print: 8.530 S Dec 6 2021 MiTek Industries, Inc. Wed Apr 06 15:10:09
ID:DvxRRPZUOfexK?LEYnrjRDzTipV-RfC?PsB70Hq3NSgPqnL8w3ulTXbGKwRCDoi7J4zJC?

Page: 1

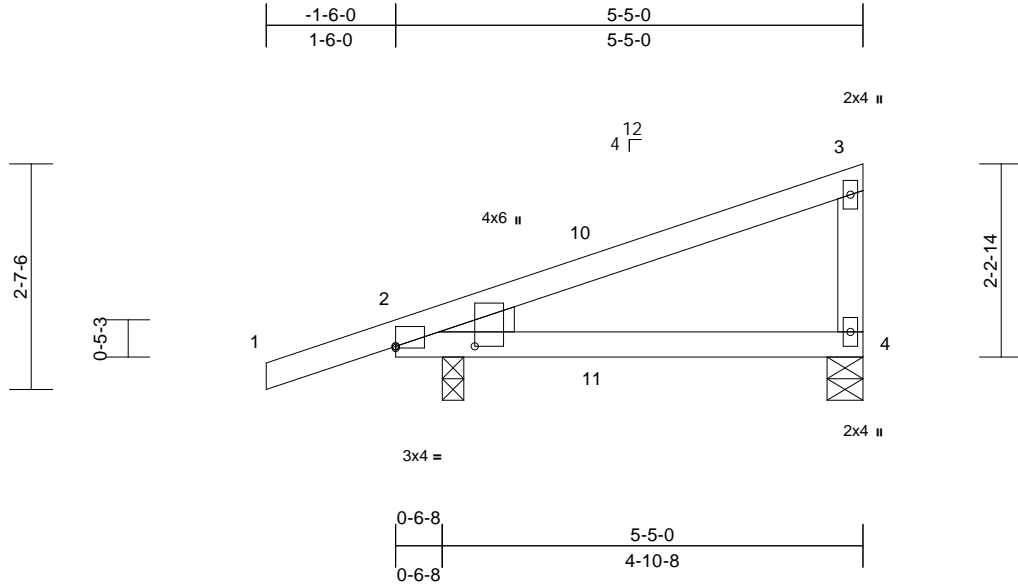

Scale = 1:26.7

Plate Offsets (X, Y): [2:Edge,0-0-4], [2:Edge,0-11-0]

Loading	(psf)	Spacing	2-0-0	CSI	DEFL	in	(loc)	l/defl	L/d	PLATES	GRIP	
TCLL (roof)	20.0	Plate Grip DOL	1.25	TC	0.53	Vert(LL)	0.12	4-9	>546	240	MT20	244/190
TCDL	10.0	Lumber DOL	1.25	BC	0.58	Vert(CT)	-0.04	4-9	>999	240		
BCLL	0.0*	Rep Stress Incr	YES	WB	0.00	Horz(CT)	-0.01	2	n/a	n/a		
BCDL	10.0	Code	FBC2020/TPI2014	Matrix-AS							Weight: 23 lb	FT = 20%

LUMBER

TOP CHORD 2x4 SP No.2
 BOT CHORD 2x4 SP No.2
 WEBS 2x4 SP No.3
 WEDGE Left: 2x4 SP No.3

6) This truss design requires that a minimum of 7/16" structural wood sheathing be applied directly to the top chord and 1/2" gypsum sheetrock be applied directly to the bottom chord.

LOAD CASE(S) Standard

BRACING

TOP CHORD Structural wood sheathing directly applied, except end verticals.
 BOT CHORD Rigid ceiling directly applied.

REACTIONS

(lb/size) 2=349/0-3-0, 4=162/0-5-0
 Max Horiz 2=147 (LC 6)
 Max Uplift 2=-324 (LC 6), 4=-158 (LC 6)

FORCES

(lb) - Maximum Compression/Maximum Tension
 TOP CHORD 1-2=0/28, 2-3=-641/271, 3-4=-128/298
 BOT CHORD 2-4=-263/718

NOTES

- 1) Wind: ASCE 7-16; Vult=140mph (3-second gust)
 Vasd=108mph; TCDL=4.2psf; BCDL=5.0psf; h=25ft;
 Cat. II; Exp C; Enclosed; MWFRS (envelope) exterior zone and C-C Exterior(2E) -1-6-0 to 1-4-8, Interior (1) 1-4-8 to 2-3-4, Exterior(2E) 2-3-4 to 5-3-4 zone;
 cantilever left exposed ; porch left and right exposed;C-C for members and forces & MWFRS for reactions shown; Lumber DOL=1.60 plate grip DOL=1.60
- 2) Building Designer / Project engineer responsible for verifying applied roof live load shown covers rain loading requirements specific to the use of this truss component.
- 3) This truss has been designed for a 10.0 psf bottom chord live load nonconcurrent with any other live loads.
- 4) * This truss has been designed for a live load of 20.0psf on the bottom chord in all areas where a rectangle 3-06-00 tall by 2-00-00 wide will fit between the bottom chord and any other members.
- 5) Provide mechanical connection (by others) of truss to bearing plate capable of withstanding 158 lb uplift at joint 4 and 324 lb uplift at joint 2.

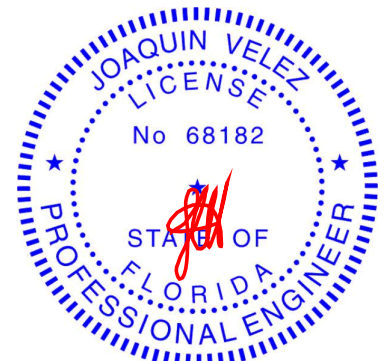

Joaquin Velez PE No.68182
 MiTek USA, Inc. FL Cert 6634
 6904 Parke East Blvd. Tampa FL 33610
 Date:

April 7, 2022

WARNING - Verify design parameters and READ NOTES ON THIS AND INCLUDED MITEK REFERENCE PAGE MII-7473 rev. 5/19/2020 BEFORE USE.

Design valid for use only with MiTek® connectors. This design is based only upon parameters shown, and is for an individual building component, not a truss system. Before use, the building designer must verify the applicability of design parameters and properly incorporate this design into the overall building design. Bracing indicated is to prevent buckling of individual truss web and/or chord members only. Additional temporary and permanent bracing is always required for stability and to prevent collapse with possible personal injury and property damage. For general guidance regarding the fabrication, storage, delivery, erection and bracing of trusses and truss systems, see

ANSI/TPI1 Quality Criteria, DSB-89 and BCSI Building Component

Safety Information available from Truss Plate Institute, 2670 Crain Highway, Suite 203 Waldorf, MD 20601



6904 Parke East Blvd.
 Tampa, FL 36610

Job 3039076	Truss M02	Truss Type Monopitch	Qty 4	Ply 1	Job Reference (optional) T27365437
----------------	--------------	-------------------------	----------	----------	---------------------------------------

Builders FirstSource (Groveland, FL), Groveland, FL - 34736,

Run: 8.53 S Dec 6 2021 Print: 8.530 S Dec 6 2021 MiTek Industries, Inc. Wed Apr 06 15:10:09
ID:p8qaWq8b4Phj5N0TMsj_NLzTiol-RfC?PsB70Hq3NSgPqnL8w3uITXbGKWrCDoi7J4zJC?f

Page: 1

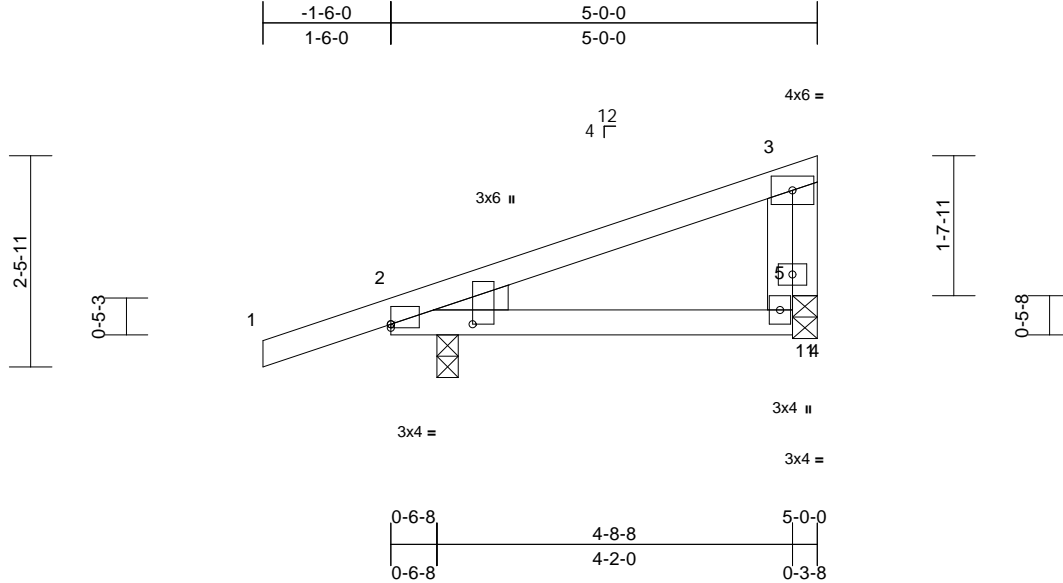

Scale = 1:27
Plate Offsets (X, Y): [2:Edge,0-0-8], [2:Edge,0-11-8]

Loading	(psf)	Spacing	2-0-0	CSI	DEFL	in	(loc)	l/defl	L/d	PLATES	GRIP	
TCLL (roof)	20.0	Plate Grip DOL	1.25	TC	0.31	Vert(LL)	0.02	4-10	>999	240	MT20	244/190
TCDL	10.0	Lumber DOL	1.25	BC	0.23	Vert(CT)	-0.01	4-10	>999	240		
BCLL	0.0*	Rep Stress Incr	YES	WB	0.00	Horz(CT)	0.00	2	n/a	n/a		
BCDL	10.0	Code	FBC2020/TPI2014	Matrix-AS							Weight: 23 lb	FT = 20%

LUMBER
TOP CHORD 2x4 SP No.2
BOT CHORD 2x4 SP No.2
WEBS 2x4 SP No.3
OTHERS 2x4 SP No.3
WEDGE Left: 2x4 SP No.3

BRACING
TOP CHORD Structural wood sheathing directly applied, except end verticals.
BOT CHORD Rigid ceiling directly applied.

REACTIONS (lb/size) 2=335/0-3-0, 11=120/0-3-8
Max Horiz 2=132 (LC 6)
Max Uplift 2=-315 (LC 6), 11=-116 (LC 6)

FORCES (lb) - Maximum Compression/Maximum Tension
TOP CHORD 1-2=0/28, 2-3=-650/272, 4-5=-210/75, 3-5=-89/79
BOT CHORD 2-4=-262/724
WEBS 3-11=-68/204

- Bearing at joint(s) 11 considers parallel to grain value using ANSI/TPI 1 angle to grain formula. Building designer should verify capacity of bearing surface.
- Provide mechanical connection (by others) of truss to bearing plate capable of withstanding 315 lb uplift at joint 2 and 116 lb uplift at joint 11.
- This truss design requires that a minimum of 7/16" structural wood sheathing be applied directly to the top chord and 1/2" gypsum sheetrock be applied directly to the bottom chord.

LOAD CASE(S) Standard

- NOTES**
- Wind: ASCE 7-16; Vult=140mph (3-second gust)
Vasd=108mph; TCDL=4.2psf; BCDL=5.0psf; h=25ft;
Cat. II; Exp C; Enclosed; MWFRS (envelope) exterior zone and C-C Exterior(2E) -1-6-0 to 1-4-8, Interior (1) 1-4-8 to 4-6-12 zone; cantilever left exposed; porch left and right exposed; C-C for members and forces & MWFRS for reactions shown; Lumber DOL=1.60 plate grip DOL=1.60
 - Building Designer / Project engineer responsible for verifying applied roof live load shown covers rain loading requirements specific to the use of this truss component.
 - This truss has been designed for a 10.0 psf bottom chord live load nonconcurrent with any other live loads.
 - * This truss has been designed for a live load of 20.0psf on the bottom chord in all areas where a rectangle 3-06-00 tall by 2-00-00 wide will fit between the bottom chord and any other members.

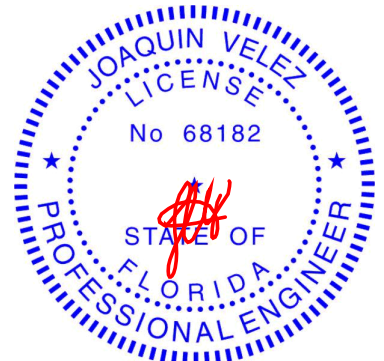

Joaquin Velez PE No.68182
MiTek USA, Inc. FL Cert 6634
6904 Parke East Blvd. Tampa FL 33610
Date:

April 7, 2022

Job 3039076	Truss M03	Truss Type Jack-Closed	Qty 1	Ply 1	Job Reference (optional) T27365438
----------------	--------------	---------------------------	----------	----------	---------------------------------------

Builders FirstSource (Groveland, FL), Groveland, FL - 34736,

Run: 8.53 S Dec 6 2021 Print: 8.530 S Dec 6 2021 MiTek Industries, Inc. Wed Apr 06 15:10:09
ID:TWzWIFul31k8jpezhMPLQjzTmoj-RfC?PsB70Hq3NSgPqnL8w3ulTXbGKWRcDoi7J4zJC?f

Page: 1

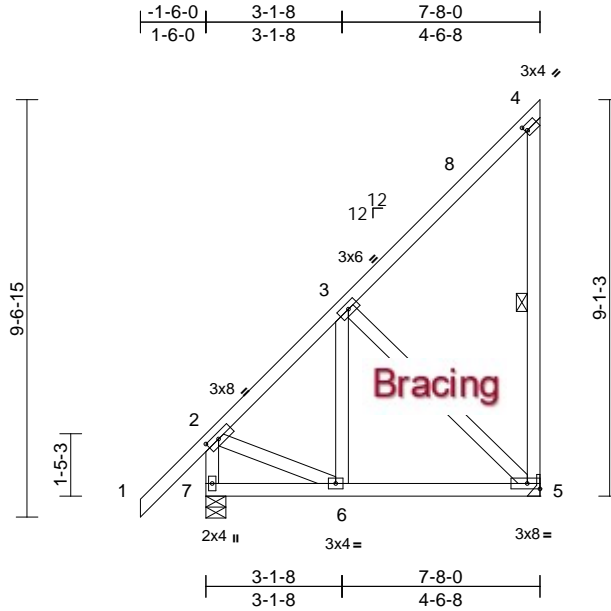

Scale = 1:52.9

Plate Offsets (X, Y): [2:0-3-7,0-1-8], [4:0-0-9,0-1-8]

Loading	(psf)	Spacing	2-0-0	CSI	DEFL	in	(loc)	l/defl	L/d	PLATES	GRIP	
TCLL (roof)	20.0	Plate Grip DOL	1.25	TC	0.87	Vert(LL)	-0.03	5-6	>999	240	MT20	244/190
TCDL	10.0	Lumber DOL	1.25	BC	0.34	Vert(CT)	-0.04	5-6	>999	180		
BCLL	0.0*	Rep Stress Incr	YES	WB	0.31	Horz(CT)	0.00	5	n/a	n/a		
BCDL	10.0	Code	FBC2020/TPI2014	Matrix-MS							Weight: 64 lb	FT = 20%

LUMBER
TOP CHORD 2x4 SP No.2
BOT CHORD 2x4 SP No.2
WEBS 2x4 SP No.3 *Except* 4-5:2x4 SP No.2

BRACING
TOP CHORD Structural wood sheathing directly applied or 6-0-0 oc purlins, except end verticals.
BOT CHORD Rigid ceiling directly applied or 6-0-0 oc bracing.

REACTIONS (lb/size) 5=284/ Mechanical, 7=405/0-5-8
Max Horiz 7=547 (LC 7)
Max Uplift 5=-354 (LC 7), 7=-112 (LC 6)
Max Grav 5=446 (LC 17), 7=491 (LC 18)

FORCES (lb) - Maximum Compression/Maximum Tension
TOP CHORD 2-7=-480/278, 1-2=0/70, 2-3=-407/191, 3-4=-310/192, 4-5=-191/197
BOT CHORD 6-7=-499/309, 5-6=-269/268
WEBS 3-5=-449/330, 3-6=-40/131, 2-6=-93/319

- NOTES**
- 1) Wind: ASCE 7-16; Vult=140mph (3-second gust) Vasd=108mph; TC DL=4.2psf; BCDL=5.0psf; h=25ft; Cat. II; Exp C; Enclosed; MWFRS (envelope) exterior zone and C-C Exterior(2E) -1-6-0 to 1-6-0, Interior (1) 1-6-0 to 3-1-8, Exterior(2R) 3-1-8 to 7-6-4 zone; end vertical left and right exposed; C-C for members and forces & MWFRS for reactions shown; Lumber DOL=1.60 plate grip DOL=1.60
 - 2) Building Designer / Project engineer responsible for verifying applied roof live load shown covers rain loading requirements specific to the use of this truss component.
 - 3) This truss has been designed for a 10.0 psf bottom chord live load nonconcurrent with any other live loads.

- 4) * This truss has been designed for a live load of 20.0psf on the bottom chord in all areas where a rectangle 3-06-00 tall by 2-00-00 wide will fit between the bottom chord and any other members.
- 5) Refer to girder(s) for truss to truss connections.
- 6) Provide mechanical connection (by others) of truss to bearing plate capable of withstanding 112 lb uplift at joint 7 and 354 lb uplift at joint 5.

LOAD CASE(S) Standard

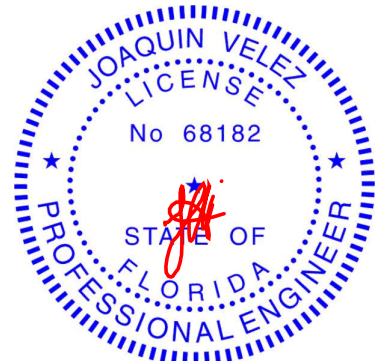

Joaquin Velez PE No.68182
MiTek USA, Inc. FL Cert 6634
6904 Parke East Blvd. Tampa FL 33610
Date:

April 7, 2022

WARNING - Verify design parameters and READ NOTES ON THIS AND INCLUDED MITEK REFERENCE PAGE MII-7473 rev. 5/19/2020 BEFORE USE.
Design valid for use only with MiTek® connectors. This design is based only upon parameters shown, and is for an individual building component, not a truss system. Before use, the building designer must verify the applicability of design parameters and properly incorporate this design into the overall building design. Bracing indicated is to prevent buckling of individual truss web and/or chord members only. Additional temporary and permanent bracing is always required for stability and to prevent collapse with possible personal injury and property damage. For general guidance regarding the fabrication, storage, delivery, erection and bracing of trusses and truss systems, see **ANSI/TPI1 Quality Criteria, DSB-89 and BCSI Building Component Safety Information** available from Truss Plate Institute, 2670 Crain Highway, Suite 203 Waldorf, MD 20601



Job 3039076	Truss M04	Truss Type Jack-Open Supported Gable	Qty 1	Ply 1	Job Reference (optional) T27365439
----------------	--------------	---	----------	----------	---------------------------------------

Builders FirstSource (Groveland, FL), Groveland, FL - 34736,

Run: 8.53 S Jan 6 2022 Print: 8.530 S Jan 6 2022 MiTek Industries, Inc. Thu Apr 07 00:40:28

Page: 1

ID:Wsm?JTHB1hdOwbanAsVRJzTU1E-ptXWgqX?Qy2MDDuLo5yNtMWExgWecaKDyNPPLuzTGip

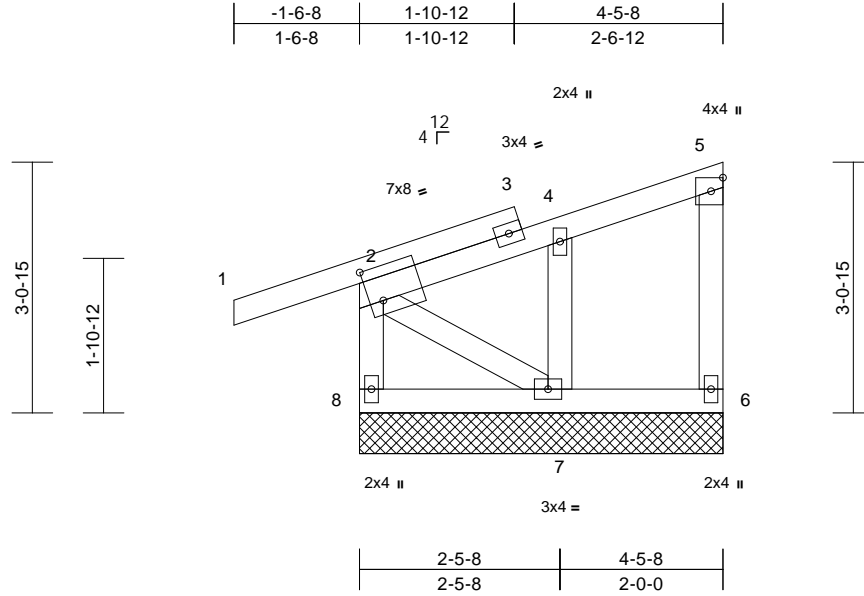

Scale = 1:28.3

Plate Offsets (X, Y): [2:0-2:0,0-5:0]

Loading	(psf)	Spacing	2-0-0	CSI	DEFL	in	(loc)	l/defl	L/d	PLATES	GRIP	
TCLL (roof)	20.0	Plate Grip DOL	1.25	TC	0.44	Vert(LL)	n/a	-	n/a	999	MT20	244/190
TCDL	10.0	Lumber DOL	1.25	BC	0.04	Vert(CT)	n/a	-	n/a	999		
BCLL	0.0*	Rep Stress Incr	YES	WB	0.12	Horz(CT)	0.00	6	n/a	n/a		
BCDL	10.0	Code	FBC2020/TPI2014	Matrix-AS							Weight: 31 lb	FT = 20%

LUMBER
TOP CHORD 2x4 SP No.2
BOT CHORD 2x4 SP No.2
WEBS 2x4 SP No.3
OTHERS 2x4 SP No.3

BRACING
TOP CHORD Structural wood sheathing directly applied, except end verticals.
BOT CHORD Rigid ceiling directly applied.

REACTIONS (lb/size) 6=59/4-5-8, 7=156/4-5-8, 8=219/4-5-8
Max Horiz 8=112 (LC 7)
Max Uplift 6=-42 (LC 6), 7=-130 (LC 10), 8=-142 (LC 6)

FORCES (lb) - Max. Comp./Max. Ten. - All forces 250 (lb) or less except when shown.

TOP CHORD 2-8=-201/347
BOT CHORD 7-8=-328/81
WEBS 2-7=-97/391

NOTES

- 1) Wind: ASCE 7-16; Vult=140mph (3-second gust) Vasd=108mph; TCDL=4.2psf; BCDL=5.0psf; h=25ft; Cat. II; Exp C; Enclosed; MWFRS (envelope) exterior zone and C-C Corner(3E) zone; end vertical left exposed; C-C for members and forces & MWFRS for reactions shown; Lumber DOL=1.60 plate grip DOL=1.60
- 2) Truss designed for wind loads in the plane of the truss only. For studs exposed to wind (normal to the face), see Standard Industry Gable End Details as applicable, or consult qualified building designer as per ANSI/TPI 1.
- 3) Building Designer / Project engineer responsible for verifying applied roof live load shown covers rain loading requirements specific to the use of this truss component.
- 4) Gable requires continuous bottom chord bearing.
- 5) Truss to be fully sheathed from one face or securely braced against lateral movement (i.e. diagonal web).

- 6) Gable studs spaced at 2-0-0 oc.
- 7) This truss has been designed for a 10.0 psf bottom chord live load nonconcurrent with any other live loads.
- 8) * This truss has been designed for a live load of 20.0psf on the bottom chord in all areas where a rectangle 3-06-00 tall by 2-00-00 wide will fit between the bottom chord and any other members.
- 9) Provide mechanical connection (by others) of truss to bearing plate capable of withstanding 142 lb uplift at joint 8, 42 lb uplift at joint 6 and 130 lb uplift at joint 7.
- 10) This truss design requires that a minimum of 7/16" structural wood sheathing be applied directly to the top chord and 1/2" gypsum sheetrock be applied directly to the bottom chord.

LOAD CASE(S) Standard

LATERALLY BRACE TOP CHORD WITH PURLINS AT 2-0-0 o/c IF STRUCTURAL SHEATHING IS NOT DIRECTLY APPLIED.

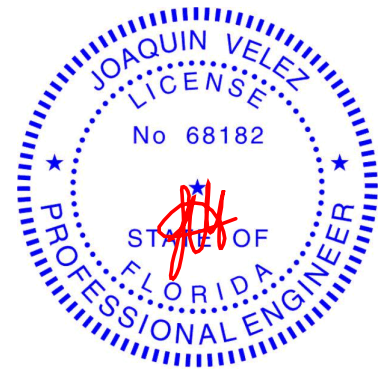

Joaquin Velez PE No.68182
MiTek USA, Inc. FL Cert 6634
6904 Parke East Blvd. Tampa FL 33610
Date:

April 7, 2022

WARNING - Verify design parameters and READ NOTES ON THIS AND INCLUDED MITEK REFERENCE PAGE MII-7473 rev. 5/19/2020 BEFORE USE.

Design valid for use only with MiTek® connectors. This design is based only upon parameters shown, and is for an individual building component, not a truss system. Before use, the building designer must verify the applicability of design parameters and properly incorporate this design into the overall building design. Bracing indicated is to prevent buckling of individual truss web and/or chord members only. Additional temporary and permanent bracing is always required for stability and to prevent collapse with possible personal injury and property damage. For general guidance regarding the fabrication, storage, delivery, erection and bracing of trusses and truss systems, see

ANSI/TPI1 Quality Criteria, DSB-89 and BCSI Building Component

Safety Information available from Truss Plate Institute, 2670 Crain Highway, Suite 203 Waldorf, MD 20601



6904 Parke East Blvd.
Tampa, FL 33610

Job 3039076	Truss M05	Truss Type Jack-Closed	Qty 2	Ply 1	Job Reference (optional) T27365440
----------------	--------------	---------------------------	----------	----------	---------------------------------------

Builders FirstSource (Groveland, FL), Groveland, FL - 34736,

Run: 8:53 S Dec 6 2021 Print: 8:530 S Dec 6 2021 MiTek Industries, Inc. Wed Apr 06 15:10:10
ID:xE1PCn79TdUztEjyyWq9dzTU0O-RfC?PsB70Hq3NSgPqnL8w3uITXbGKWrCDoi7J4zJC?f

Page: 1

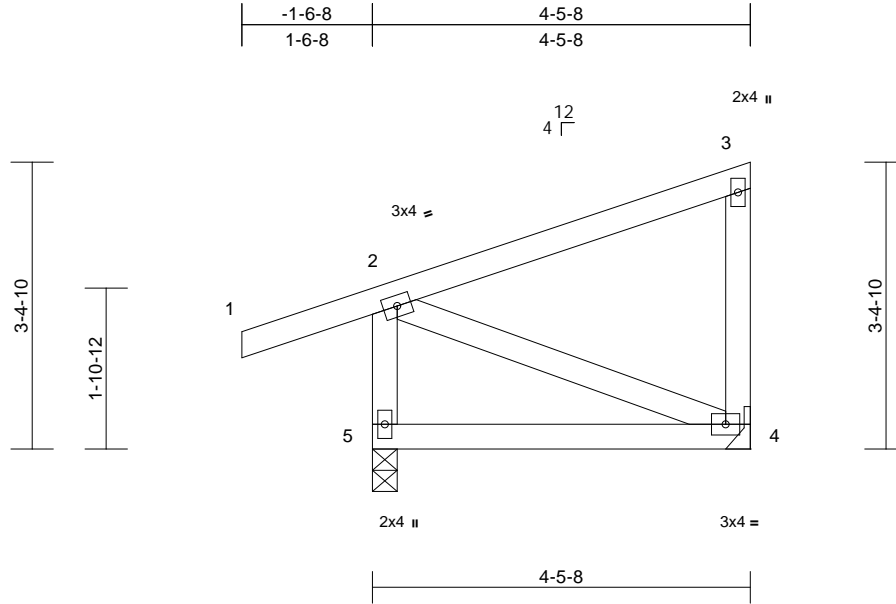

Loading	(psf)	Spacing	2-0-0	CSI	DEFL	in	(loc)	l/defl	L/d	PLATES	GRIP	
TCLL (roof)	20.0	Plate Grip DOL	1.25	TC	0.35	Vert(LL)	-0.02	4-5	>999	360	MT20	244/190
TCDL	10.0	Lumber DOL	1.25	BC	0.21	Vert(CT)	-0.04	4-5	>999	240		
BCLL	0.0*	Rep Stress Incr	YES	WB	0.10	Horz(CT)	0.00	4	n/a	n/a		
BCDL	10.0	Code	FBC2020/TPI2014	Matrix-AS							Weight: 29 lb	FT = 20%

LUMBER
 TOP CHORD 2x4 SP No.2
 BOT CHORD 2x4 SP No.2
 WEBS 2x4 SP No.3

BRACING
 TOP CHORD Structural wood sheathing directly applied, except end verticals.
 BOT CHORD Rigid ceiling directly applied.

REACTIONS (lb/size) 4=146/ Mechanical, 5=288/0-3-8
 Max Horiz 5=128 (LC 7)
 Max Uplift 4=-123 (LC 10), 5=-180 (LC 6)

FORCES (lb) - Maximum Compression/Maximum Tension
 TOP CHORD 1-2=0/32, 2-3=-87/44, 3-4=-146/240, 2-5=-247/397
 BOT CHORD 4-5=-322/87
 WEBS 2-4=-94/346

- NOTES**
- 1) Wind: ASCE 7-16; Vult=140mph (3-second gust) Vasd=108mph; TCDL=4.2psf; BCDL=5.0psf; h=25ft; Cat. II; Exp C; Enclosed; MWFRS (envelope) exterior zone and C-C Exterior(2E) zone; end vertical left exposed; C-C for members and forces & MWFRS for reactions shown; Lumber DOL=1.60 plate grip DOL=1.60
 - 2) Building Designer / Project engineer responsible for verifying applied roof live load shown covers rain loading requirements specific to the use of this truss component.
 - 3) This truss has been designed for a 10.0 psf bottom chord live load nonconcurrent with any other live loads.
 - 4) * This truss has been designed for a live load of 20.0psf on the bottom chord in all areas where a rectangle 3-06-00 tall by 2-00-00 wide will fit between the bottom chord and any other members.
 - 5) Refer to girder(s) for truss to truss connections.
 - 6) Provide mechanical connection (by others) of truss to bearing plate capable of withstanding 180 lb uplift at joint 5 and 123 lb uplift at joint 4.

7) This truss design requires that a minimum of 7/16" structural wood sheathing be applied directly to the top chord and 1/2" gypsum sheetrock be applied directly to the bottom chord.

LOAD CASE(S) Standard

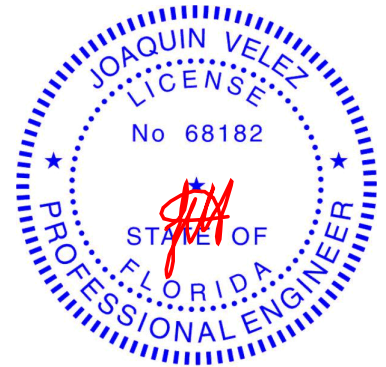

Joaquin Velez PE No.68182
 MiTek USA, Inc. FL Cert 6634
 6904 Parke East Blvd. Tampa FL 33610
 Date:

April 7, 2022

WARNING - Verify design parameters and READ NOTES ON THIS AND INCLUDED MITEK REFERENCE PAGE MII-7473 rev. 5/19/2020 BEFORE USE.

Design valid for use only with MiTek® connectors. This design is based only upon parameters shown, and is for an individual building component, not a truss system. Before use, the building designer must verify the applicability of design parameters and properly incorporate this design into the overall building design. Bracing indicated is to prevent buckling of individual truss web and/or chord members only. Additional temporary and permanent bracing is always required for stability and to prevent collapse with possible personal injury and property damage. For general guidance regarding the fabrication, storage, delivery, erection and bracing of trusses and truss systems, see

ANSI/TPI1 Quality Criteria, DSB-89 and BCSI Building Component

Safety Information available from Truss Plate Institute, 2670 Crain Highway, Suite 203 Waldorf, MD 20601



6904 Parke East Blvd.
 Tampa, FL 36610

Job 3039076	Truss PB01	Truss Type Piggyback	Qty 1	Ply 1	Job Reference (optional) T27365441
----------------	---------------	-------------------------	----------	----------	---------------------------------------

Builders FirstSource (Groveland, FL), Groveland, FL - 34736,

Run: 8:53 S Jan 6 2022 Print: 8:530 S Jan 6 2022 MiTek Industries, Inc. Thu Apr 07 00:41:59
ID:6wDAXrCJkGZF9fVCGPKo6azTSAp-bmfgBdfKWWmAtWVDk77B8zsCf9FNueJvKLRq7?zTGhM

Page: 1

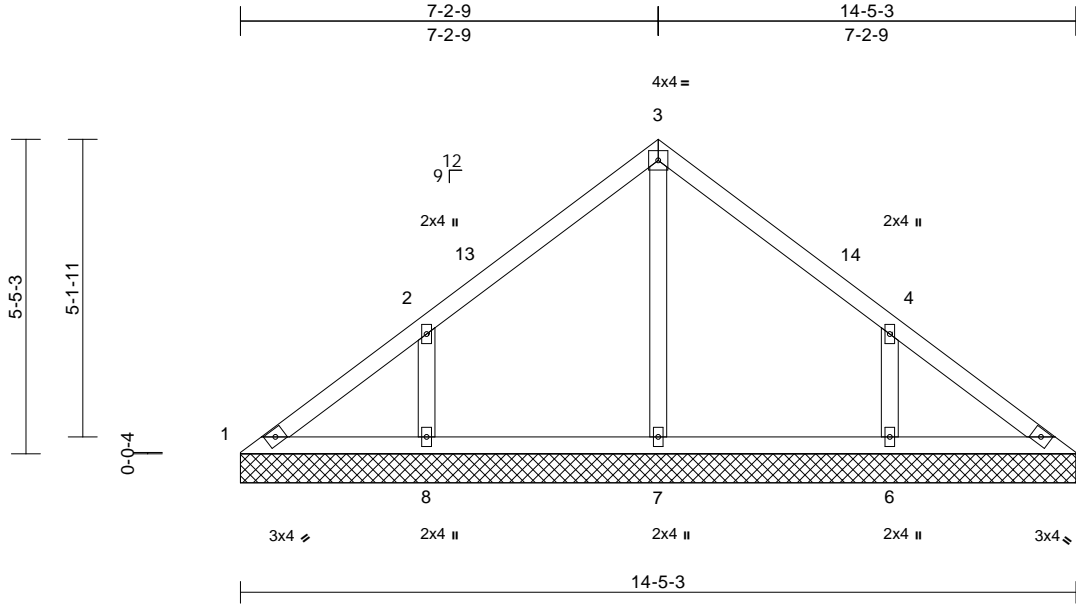

Loading	(psf)	Spacing	2-0-0	CSI	DEFL	in	(loc)	l/defl	L/d	PLATES	GRIP	
TCLL (roof)	20.0	Plate Grip DOL	1.25	TC	0.17	Vert(LL)	n/a	-	n/a	999	MT20	244/190
TCDL	10.0	Lumber DOL	1.25	BC	0.11	Vert(TL)	n/a	-	n/a	999		
BCLL	0.0*	Rep Stress Incr	YES	WB	0.12	Horiz(TL)	0.00	5	n/a	n/a		
BCDL	10.0	Code	FBC2020/TPI2014	Matrix-AS							Weight: 60 lb	FT = 20%

LUMBER
TOP CHORD 2x4 SP No.2
BOT CHORD 2x4 SP No.2
OTHERS 2x4 SP No.3

BRACING
TOP CHORD Structural wood sheathing directly applied.
BOT CHORD Rigid ceiling directly applied.

REACTIONS All bearings 14-5-3.
(lb) - Max Horiz 1=203 (LC 6)
Max Uplift All uplift 100 (lb) or less at joint(s)
1, 5, 7 except 6=304 (LC 11),
8=308 (LC 10)
Max Grav All reactions 250 (lb) or less at joint
(s) 1, 5 except 6=394 (LC 18),
7=308 (LC 1), 8=399 (LC 17)

FORCES (lb) - Max. Comp./Max. Ten. - All forces 250
(lb) or less except when shown.

WEBS 2-8=-306/331, 4-6=-304/328

- Gable studs spaced at 4-0-0 oc.
- This truss has been designed for a 10.0 psf bottom chord live load nonconcurrent with any other live loads.
- * This truss has been designed for a live load of 20.0psf on the bottom chord in all areas where a rectangle 3-06-00 tall by 2-00-00 wide will fit between the bottom chord and any other members.
- Provide mechanical connection (by others) of truss to bearing plate capable of withstanding 100 lb uplift at joint(s) 1, 5, 7 except (jt=lb) 8=308, 6=304.
- This truss design requires that a minimum of 7/16" structural wood sheathing be applied directly to the top chord and 1/2" gypsum sheetrock be applied directly to the bottom chord.
- See Standard Industry Piggyback Truss Connection Detail for Connection to base truss as applicable, or consult qualified building designer.

LOAD CASE(S) Standard

- NOTES**
- Unbalanced roof live loads have been considered for this design.
 - Wind: ASCE 7-16; Vult=140mph (3-second gust)
Vasd=108mph; TC DL=4.2psf; BCDL=5.0psf; h=25ft;
Cat. II; Exp C; Enclosed; MWFRS (envelope) exterior zone and C-C Exterior(2E) 0-8-5 to 3-10-15, Interior (1) 3-10-15 to 4-10-15, Exterior(2R) 4-10-15 to 10-10-15, Interior (1) 10-10-15 to 11-10-15, Exterior(2E) 11-10-15 to 15-1-8 zone; end vertical left and right exposed; C-C for members and forces & MWFRS for reactions shown; Lumber DOL=1.60 plate grip DOL=1.60
 - Truss designed for wind loads in the plane of the truss only. For studs exposed to wind (normal to the face), see Standard Industry Gable End Details as applicable, or consult qualified building designer as per ANSI/TPI 1.
 - Building Designer / Project engineer responsible for verifying applied roof live load shown covers rain loading requirements specific to the use of this truss component.
 - Gable requires continuous bottom chord bearing.

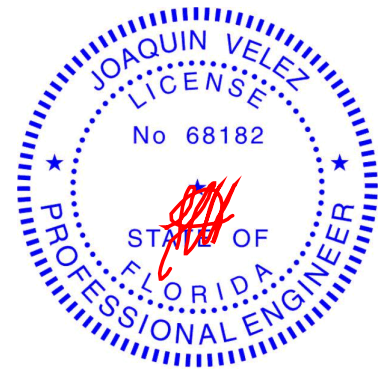

Joaquin Velez PE No.68182
MiTek USA, Inc. FL Cert 6634
6904 Parke East Blvd. Tampa FL 33610
Date:

April 7, 2022

WARNING - Verify design parameters and READ NOTES ON THIS AND INCLUDED MITEK REFERENCE PAGE MII-7473 rev. 5/19/2020 BEFORE USE.

Design valid for use only with MiTek® connectors. This design is based only upon parameters shown, and is for an individual building component, not a truss system. Before use, the building designer must verify the applicability of design parameters and properly incorporate this design into the overall building design. Bracing indicated is to prevent buckling of individual truss web and/or chord members only. Additional temporary and permanent bracing is always required for stability and to prevent collapse with possible personal injury and property damage. For general guidance regarding the fabrication, storage, delivery, erection and bracing of trusses and truss systems, see

ANSI/TPI1 Quality Criteria, DSB-89 and BCSI Building Component

Safety Information available from Truss Plate Institute, 2670 Crain Highway, Suite 203 Waldorf, MD 20601



6904 Parke East Blvd.
Tampa, FL 33610

Job 3039076	Truss PB02	Truss Type Piggyback	Qty 3	Ply 1	Job Reference (optional)	T27365442
----------------	---------------	-------------------------	----------	----------	--------------------------	-----------

Builders FirstSource (Groveland, FL), Groveland, FL - 34736,

Run: 8.53 S Dec 6 2021 Print: 8.530 S Dec 6 2021 MiTek Industries, Inc. Wed Apr 06 15:10:10
ID:lmsiZOSjTdcOgIkbbP4jzTTuJ-RFC?PsB70Hq3NSgPqnL8w3uITXbGKWrCdoi7J4zJc7f

Page: 1

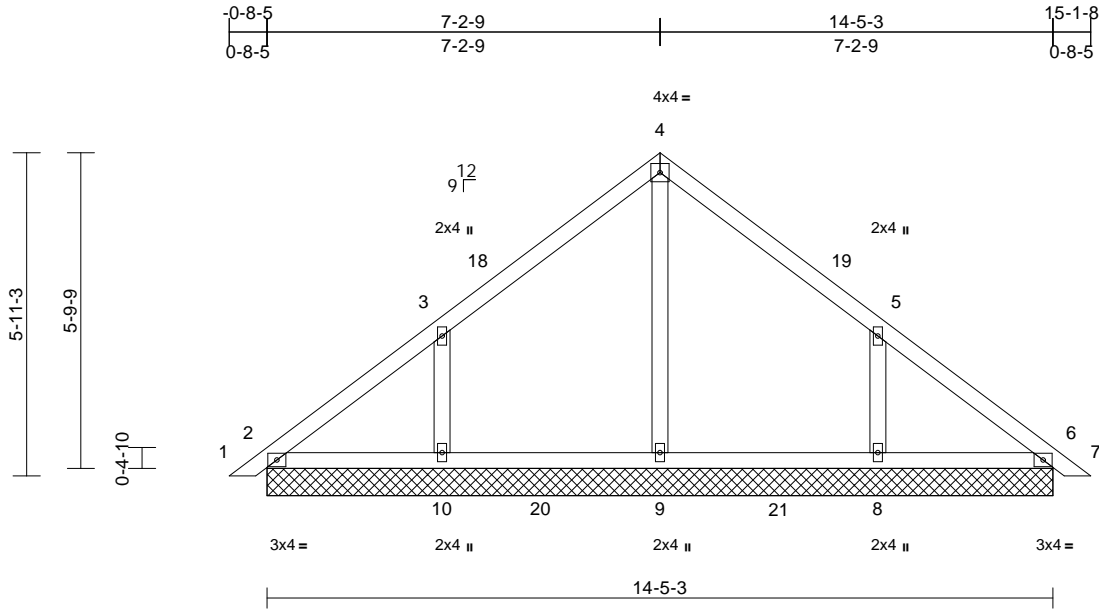

Scale = 1:42.3

Loading	(psf)	Spacing	2-0-0	CSI	DEFL	in	(loc)	l/defl	L/d	PLATES	GRIP	
TCLL (roof)	20.0	Plate Grip DOL	1.25	TC	0.17	Vert(LL)	n/a	-	n/a	999	MT20	244/190
TCDL	10.0	Lumber DOL	1.25	BC	0.16	Vert(CT)	n/a	-	n/a	999		
BCLL	0.0*	Rep Stress Incr	YES	WB	0.10	Horz(CT)	0.00	6	n/a	n/a		
BCDL	10.0	Code	FBC2020/TPI2014	Matrix-AS							Weight: 65 lb	FT = 20%

LUMBER
TOP CHORD 2x4 SP No.2
BOT CHORD 2x4 SP No.2
OTHERS 2x4 SP No.3

BRACING
TOP CHORD Structural wood sheathing directly applied.
BOT CHORD Rigid ceiling directly applied.

REACTIONS (lb/size)
2=159/14-5-3, 6=159/14-5-3,
8=326/14-5-3, 9=239/14-5-3,
10=326/14-5-3, 11=159/14-5-3,
15=159/14-5-3
Max Horiz 2=-223 (LC 8), 11=-223 (LC 8)
Max Uplift 2=-62 (LC 11), 6=-32 (LC 10),
8=-325 (LC 11), 10=-326 (LC 10),
11=-62 (LC 11), 15=-32 (LC 10)
Max Grav 2=198 (LC 18), 6=165 (LC 17),
8=467 (LC 18), 9=358 (LC 17),
10=468 (LC 17), 11=198 (LC 18),
15=165 (LC 17)

FORCES (lb) - Maximum Compression/Maximum Tension
TOP CHORD 1-2=0/16, 2-3=-175/150, 3-4=-165/191,
4-5=-152/185, 5-6=-125/79, 6-7=0/16
BOT CHORD 2-10=-69/146, 9-10=-69/146, 8-9=-69/146,
6-8=-69/146
WEBS 4-9=-165/21, 3-10=-313/344, 5-8=-312/343

NOTES
1) Unbalanced roof live loads have been considered for this design.
2) Wind: ASCE 7-16; Vult=140mph (3-second gust)
Vasd=108mph; TCDL=4.2psf; BCDL=5.0psf; h=25ft;
Cat. II; Exp C; Enclosed; MWFRS (envelope) exterior zone and C-C Exterior(2E) 0-2-15 to 3-2-15, Interior (1) 3-2-15 to 4-10-15, Exterior(2R) 4-10-15 to 10-10-15, Interior (1) 10-10-15 to 12-6-15, Exterior(2E) 12-6-15 to 15-6-15 zone; end vertical left and right exposed; C-C for members and forces & MWFRS for reactions shown; Lumber DOL=1.60 plate grip DOL=1.60

- Truss designed for wind loads in the plane of the truss only. For studs exposed to wind (normal to the face), see Standard Industry Gable End Details as applicable, or consult qualified building designer as per ANSI/TPI 1.
- Building Designer / Project engineer responsible for verifying applied roof live load shown covers rain loading requirements specific to the use of this truss component.
- Gable requires continuous bottom chord bearing.
- Gable studs spaced at 4'-0" oc.
- This truss has been designed for a 10.0 psf bottom chord live load nonconcurrent with any other live loads.
- * This truss has been designed for a live load of 20.0psf on the bottom chord in all areas where a rectangle 3'-06"-00 tall by 2'-00"-00 wide will fit between the bottom chord and any other members, with BCDL = 10.0psf.
- Provide mechanical connection (by others) of truss to bearing plate capable of withstanding 62 lb uplift at joint 2, 32 lb uplift at joint 6, 326 lb uplift at joint 10, 325 lb uplift at joint 8, 62 lb uplift at joint 2 and 32 lb uplift at joint 6.
- This truss design requires that a minimum of 7/16" structural wood sheathing be applied directly to the top chord and 1/2" gypsum sheetrock be applied directly to the bottom chord.
- See Standard Industry Piggyback Truss Connection Detail for Connection to base truss as applicable, or consult qualified building designer.

LOAD CASE(S) Standard

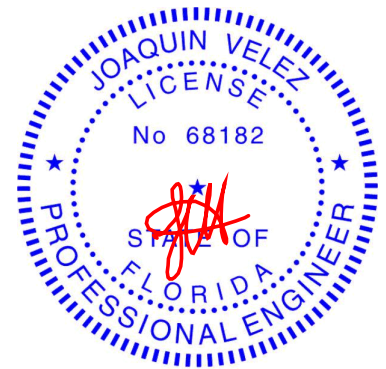

Joaquin Velez PE No.68182
MiTek USA, Inc. FL Cert 6634
6904 Parke East Blvd. Tampa FL 33610
Date:

April 7, 2022

WARNING - Verify design parameters and READ NOTES ON THIS AND INCLUDED MITEK REFERENCE PAGE MII-7473 rev. 5/19/2020 BEFORE USE.

Design valid for use only with MiTek® connectors. This design is based only upon parameters shown, and is for an individual building component, not a truss system. Before use, the building designer must verify the applicability of design parameters and properly incorporate this design into the overall building design. Bracing indicated is to prevent buckling of individual truss web and/or chord members only. Additional temporary and permanent bracing is always required for stability and to prevent collapse with possible personal injury and property damage. For general guidance regarding the fabrication, storage, delivery, erection and bracing of trusses and truss systems, see

ANSI/TPI1 Quality Criteria, DSB-89 and BCSI Building Component

Safety Information available from Truss Plate Institute, 2670 Crain Highway, Suite 203 Waldorf, MD 20601



6904 Parke East Blvd.
Tampa, FL 33610

Job 3039076	Truss PB03	Truss Type Piggyback	Qty 1	Ply 1	Job Reference (optional)	T27365443
----------------	---------------	-------------------------	----------	----------	--------------------------	-----------

Builders FirstSource (Groveland, FL), Groveland, FL - 34736,

Run: 8.53 S Jan 6 2022 Print: 8.530 S Jan 6 2022 MiTek Industries, Inc. Thu Apr 07 00:42:21
ID:MykXa41zxSIW1fFJChJ4VzTRjK-y_?p9w7LHX2WuBS1IWL1cnxU1j3Z2V8Omm_ujzTGh0

Page: 1

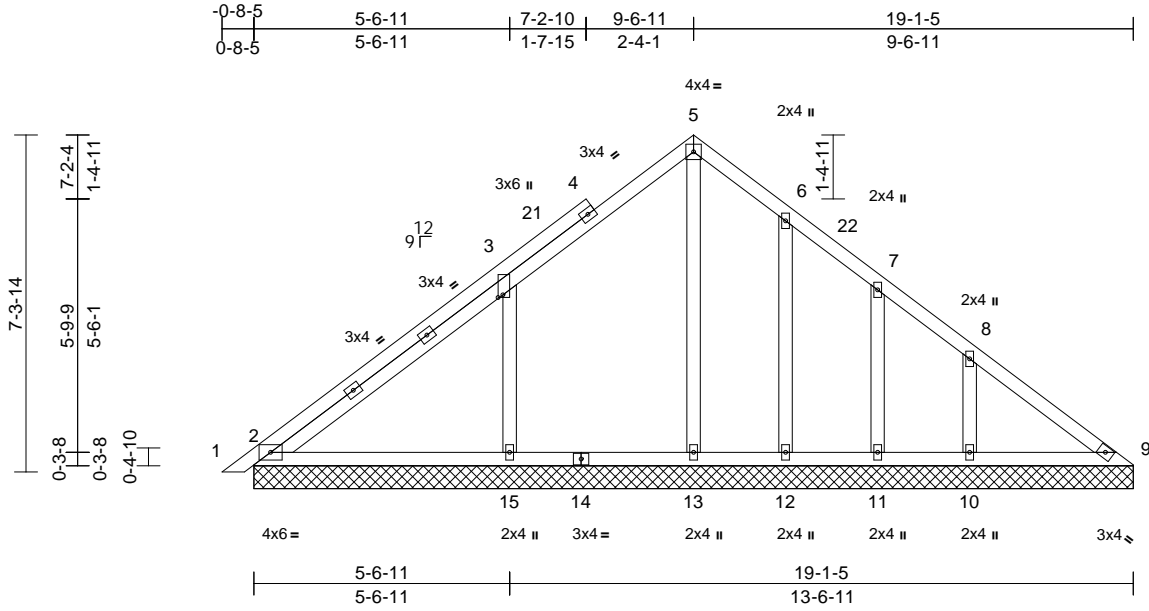

Scale = 1:50.1
Plate Offsets (X, Y): [3:0-0-11,0-1-4]

Loading	(psf)	Spacing	2-0-0	CSI	DEFL	in	(loc)	l/defl	L/d	PLATES	GRIP	
TCLL (roof)	20.0	Plate Grip DOL	1.25	TC	0.21	Vert(LL)	n/a	-	n/a	999	MT20	244/190
TCDL	10.0	Lumber DOL	1.25	BC	0.20	Vert(CT)	n/a	-	n/a	999		
BCLL	0.0*	Rep Stress Incr	YES	WB	0.20	Horz(CT)	0.01	9	n/a	n/a		
BCDL	10.0	Code	FBC2020/TPI2014	Matrix-AS							Weight: 109 lb	FT = 20%

LUMBER
TOP CHORD 2x4 SP No.2
BOT CHORD 2x4 SP No.2
WEBS 2x4 SP No.3
OTHERS 2x4 SP No.3

BRACING
TOP CHORD Structural wood sheathing directly applied.
BOT CHORD Rigid ceiling directly applied.

REACTIONS All bearings 19-1-5.
(lb) - Max Horiz 2=276 (LC 9), 16=276 (LC 9)
Max Uplift All uplift 100 (lb) or less at joint(s)
2, 13, 16 except 10=235 (LC 11),
11=125 (LC 11), 12=158 (LC 11),
15=444 (LC 10)
Max Grav All reactions 250 (lb) or less at joint
(s) 2, 9, 11, 12, 16 except 10=376
(LC 18), 13=365 (LC 20), 15=689
(LC 17)

FORCES (lb) - Max. Comp./Max. Ten. - All forces 250
(lb) or less except when shown.
TOP CHORD 2-3=-215/288
WEBS 3-15=-465/471

- NOTES**
- Unbalanced roof live loads have been considered for this design.
 - Wind: ASCE 7-16; Vult=140mph (3-second gust)
Vasd=108mph; TC DL=4.2psf; BCDL=5.0psf; h=25ft;
Cat. II; Exp C; Enclosed; MWFRS (envelope) exterior zone and C-C Exterior(2E) 0-2-15 to 3-2-15, Interior (1) 3-2-15 to 7-3-0, Exterior(2R) 7-3-0 to 13-3-0, Interior (1) 13-3-0 to 16-9-11, Exterior(2E) 16-9-11 to 19-9-11 zone; end vertical left and right exposed; C-C for members and forces & MWFRS for reactions shown; Lumber DOL=1.60 plate grip DOL=1.60
 - Truss designed for wind loads in the plane of the truss only. For studs exposed to wind (normal to the face), see Standard Industry Gable End Details as applicable, or consult qualified building designer as per ANSI/TPI 1.

- Building Designer / Project engineer responsible for verifying applied roof live load shown covers rain loading requirements specific to the use of this truss component.
- All plates are 2x4 MT20 unless otherwise indicated.
- Gable requires continuous bottom chord bearing.
- Gable studs spaced at 2-0-0 oc.
- This truss has been designed for a 10.0 psf bottom chord live load nonconcurrent with any other live loads.
- * This truss has been designed for a live load of 20.0psf on the bottom chord in all areas where a rectangle 3-06-00 tall by 2-00-00 wide will fit between the bottom chord and any other members, with BCDL = 10.0psf.
- Provide mechanical connection (by others) of truss to bearing plate capable of withstanding 100 lb uplift at joint(s) 2, 13, 2 except (it=lb) 12=157, 11=125, 10=234, 15=443.
- This truss design requires that a minimum of 7/16" structural wood sheathing be applied directly to the top chord and 1/2" gypsum sheetrock be applied directly to the bottom chord.
- See Standard Industry Piggyback Truss Connection Detail for Connection to base truss as applicable, or consult qualified building designer.

LOAD CASE(S) Standard

LATERALLY BRACE TOP CHORD WITH PURLINS AT 2-0-0 o/c IF STRUCTURAL SHEATHING IS NOT DIRECTLY APPLIED.

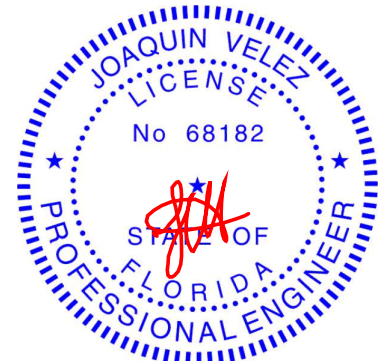

Joaquin Velez PE No.68182
MiTek USA, Inc. FL Cert 6634
6904 Parke East Blvd. Tampa FL 33610
Date:

April 7, 2022

WARNING - Verify design parameters and READ NOTES ON THIS AND INCLUDED MITEK REFERENCE PAGE MII-7473 rev. 5/19/2020 BEFORE USE.

Design valid for use only with MiTek® connectors. This design is based only upon parameters shown, and is for an individual building component, not a truss system. Before use, the building designer must verify the applicability of design parameters and properly incorporate this design into the overall building design. Bracing indicated is to prevent buckling of individual truss web and/or chord members only. Additional temporary and permanent bracing is always required for stability and to prevent collapse with possible personal injury and property damage. For general guidance regarding the fabrication, storage, delivery, erection and bracing of trusses and truss systems, see

ANSI/TPI1 Quality Criteria, DSB-89 and BCSI Building Component

Safety Information available from Truss Plate Institute, 2670 Crain Highway, Suite 203 Waldorf, MD 20601



6904 Parke East Blvd.
Tampa, FL 33610

Job 3039076	Truss PB04	Truss Type Piggyback	Qty 12	Ply 1	Job Reference (optional)	T27365444
----------------	---------------	-------------------------	-----------	----------	--------------------------	-----------

Builders FirstSource (Groveland, FL), Groveland, FL - 34736,

Run: 8.53 S Dec 6 2021 Print: 8.530 S Dec 6 2021 MiTek Industries, Inc. Wed Apr 06 15:10:11
ID:x0VOEgXzu98vqXgdR7pDZFzTTu7-RfC?PsB70Hq3NSgPqnL8w3ulTXbGKwRCDoi7J4zJC?f

Page: 1

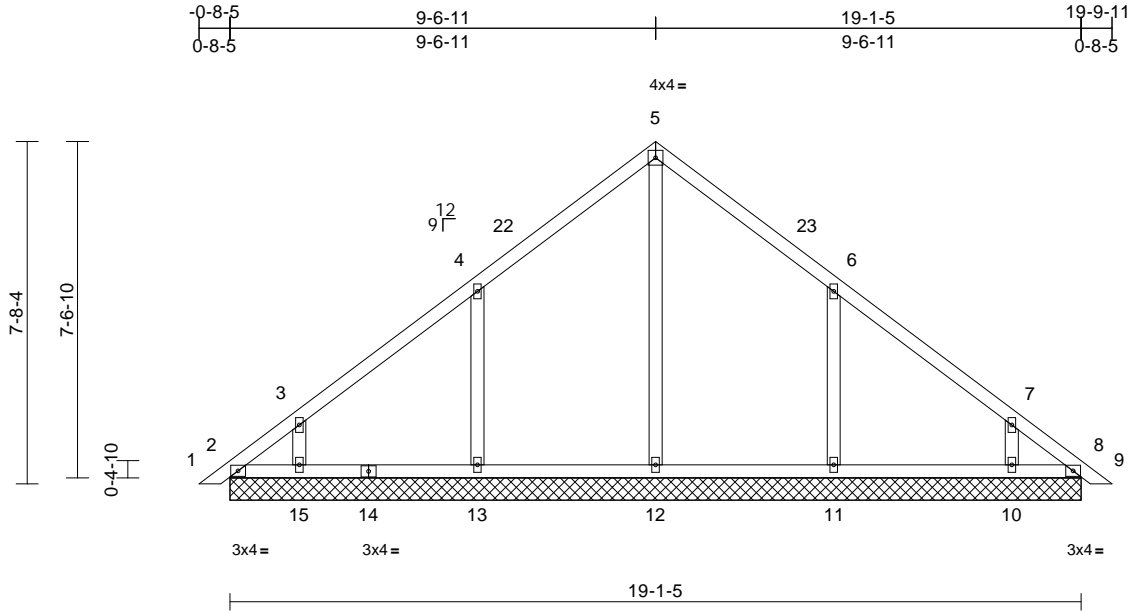

Loading	(psf)	Spacing	2-0-0	CSI	DEFL	in	(loc)	l/defl	L/d	PLATES	GRIP
TCLL (roof)	20.0	Plate Grip DOL	1.25	TC	0.20	n/a	-	n/a	999	MT20	244/190
TCDL	10.0	Lumber DOL	1.25	BC	0.17	n/a	-	n/a	999		
BCLL	0.0*	Rep Stress Incr	YES	WB	0.19	Horz(CT)	0.01	19	n/a		
BCDL	10.0	Code	FBC2020/TPI2014	Matrix-AS						Weight: 92 lb	FT = 20%

LUMBER
 TOP CHORD 2x4 SP No.2
 BOT CHORD 2x4 SP No.2
 OTHERS 2x4 SP No.3

BRACING
 TOP CHORD Structural wood sheathing directly applied.
 BOT CHORD Rigid ceiling directly applied.

REACTIONS (lb/size)
 2=73/19-1-5, 8=73/19-1-5,
 10=255/19-1-5, 11=341/19-1-5,
 12=245/19-1-5, 13=341/19-1-5,
 15=255/19-1-5, 16=73/19-1-5,
 19=73/19-1-5
 Max Horiz 2=-290 (LC 8), 16=-290 (LC 8)
 Max Uplift 2=-105 (LC 8), 8=47 (LC 7),
 10=-249 (LC 11), 11=-333 (LC 11),
 13=-334 (LC 10), 15=-250 (LC 10),
 16=-105 (LC 8), 19=-47 (LC 7)
 Max Grav 2=155 (LC 10), 8=120 (LC 20),
 10=351 (LC 18), 11=507 (LC 18),
 12=400 (LC 20), 13=507 (LC 17),
 15=353 (LC 17), 16=155 (LC 10),
 19=120 (LC 20)

FORCES (lb) - Maximum Compression/Maximum Tension
 TOP CHORD 1-2=0/16, 2-3=-302/229, 3-4=-212/171,
 4-5=-168/245, 5-6=-168/212, 6-7=-142/78,
 7-8=-239/135, 8-9=0/16
 BOT CHORD 2-15=-101/211, 13-15=-101/211,
 12-13=-101/211, 11-12=-101/211,
 10-11=-101/211, 8-10=-101/211
 WEBS 5-12=-194/12, 4-13=-332/374,
 3-15=-247/292, 6-11=-332/374,
 7-10=-246/292

NOTES
 1) Unbalanced roof live loads have been considered for this design.

- Wind: ASCE 7-16; Vult=140mph (3-second gust)
 Vasd=108mph; TCDL=4.2psf; BCDL=5.0psf; h=25ft;
 Cat. II; Exp C; Enclosed; MWFRS (envelope) exterior zone and C-C Exterior(2E) 0-2-15 to 3-2-15, Interior (1) 3-2-15 to 7-3-0, Exterior(2R) 7-3-0 to 13-3-0, Interior (1) 13-3-0 to 17-3-1, Exterior(2E) 17-3-1 to 20-3-1 zone; end vertical left and right exposed; C-C for members and forces & MWFRS for reactions shown; Lumber DOL=1.60 plate grip DOL=1.60
- Truss designed for wind loads in the plane of the truss only. For studs exposed to wind (normal to the face), see Standard Industry Gable End Details as applicable, or consult qualified building designer as per ANSI/TPI 1.
- Building Designer / Project engineer responsible for verifying applied roof live load shown covers rain loading requirements specific to the use of this truss component.
- All plates are 2x4 MT20 unless otherwise indicated.
- Gable requires continuous bottom chord bearing.
- Gable studs spaced at 4-0-0 oc.
- This truss has been designed for a 10.0 psf bottom chord live load nonconcurrent with any other live loads.
- * This truss has been designed for a live load of 20.0psf on the bottom chord in all areas where a rectangle 3-06-00 tall by 2-00-00 wide will fit between the bottom chord and any other members, with BCDL = 10.0psf.
- Provide mechanical connection (by others) of truss to bearing plate capable of withstanding 105 lb uplift at joint 2, 334 lb uplift at joint 13, 250 lb uplift at joint 15, 333 lb uplift at joint 11, 249 lb uplift at joint 10, 47 lb uplift at joint 8, 105 lb uplift at joint 2 and 47 lb uplift at joint 8.
- This truss design requires that a minimum of 7/16" structural wood sheathing be applied directly to the top chord and 1/2" gypsum sheetrock be applied directly to the bottom chord.
- See Standard Industry Piggyback Truss Connection Detail for Connection to base truss as applicable, or consult qualified building designer.

LOAD CASE(S) Standard

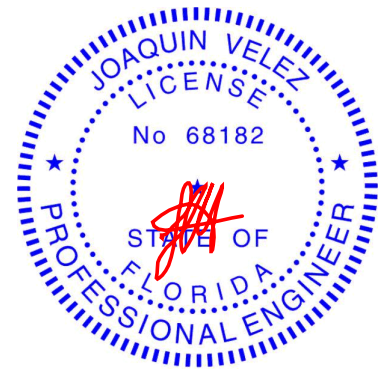

Joaquin Velez PE No.68182
 MiTek USA, Inc. FL Cert 6634
 6904 Parke East Blvd. Tampa FL 33610
 Date:

April 7, 2022

WARNING - Verify design parameters and READ NOTES ON THIS AND INCLUDED MITEK REFERENCE PAGE MII-7473 rev. 5/19/2020 BEFORE USE.

Design valid for use only with MiTek® connectors. This design is based only upon parameters shown, and is for an individual building component, not a truss system. Before use, the building designer must verify the applicability of design parameters and properly incorporate this design into the overall building design. Bracing indicated is to prevent buckling of individual truss web and/or chord members only. Additional temporary and permanent bracing is always required for stability and to prevent collapse with possible personal injury and property damage. For general guidance regarding the fabrication, storage, delivery, erection and bracing of trusses and truss systems, see

ANSI/TPI1 Quality Criteria, DSB-89 and BCSI Building Component

Safety Information available from Truss Plate Institute, 2670 Crain Highway, Suite 203 Waldorf, MD 20601



6904 Parke East Blvd.
 Tampa, FL 33610

Job 3039076	Truss PB05	Truss Type Piggyback	Qty 4	Ply 1	Job Reference (optional) T27365445
----------------	---------------	-------------------------	----------	----------	---------------------------------------

Builders FirstSource (Groveland, FL), Groveland, FL - 34736,

Run: 8:53 S Dec 6 2021 Print: 8:530 S Dec 6 2021 MiTek Industries, Inc. Wed Apr 06 15:10:11
ID: BIXo7ledmwGdQvsMTVTKQ9zTTu_-RfC?PsB70Hq3NSgPqnL8w3uITXbGKWrCDoi7J4zJC7f

Page: 1

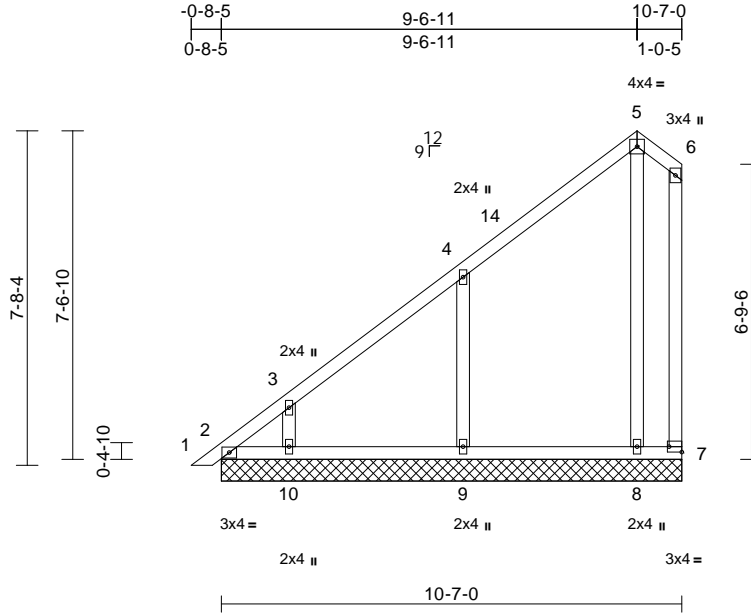

Scale = 1:53

Plate Offsets (X, Y): [7:Edge,0-1-8]

Loading	(psf)	Spacing	2-0-0	CSI	DEFL	in	(loc)	l/defl	L/d	PLATES	GRIP	
TCLL (roof)	20.0	Plate Grip DOL	1.25	TC	0.66	Vert(LL)	n/a	-	n/a	999	MT20	244/190
TCDL	10.0	Lumber DOL	1.25	BC	0.28	Vert(CT)	n/a	-	n/a	999		
BCLL	0.0*	Rep Stress Incr	YES	WB	0.28	Horz(CT)	0.00	7	n/a	n/a		
BCDL	10.0	Code	FBC2020/TPI2014	Matrix-AS							Weight: 64 lb	FT = 20%

LUMBER

TOP CHORD 2x4 SP No.2
 BOT CHORD 2x4 SP No.2
 WEBS 2x4 SP No.3
 OTHERS 2x4 SP No.3

BRACING

TOP CHORD Structural wood sheathing directly applied, except end verticals.
 BOT CHORD Rigid ceiling directly applied.

REACTIONS

(lb/size) 2=46/10-7-0, 7=-26/10-7-0, 8=240/10-7-0, 9=350/10-7-0, 10=253/10-7-0, 11=46/10-7-0
 Max Horiz 2=421 (LC 9), 11=421 (LC 9)
 Max Uplift 2=-138 (LC 8), 7=-98 (LC 17), 8=-151 (LC 7), 9=-329 (LC 10), 10=-255 (LC 10), 11=-138 (LC 8)
 Max Grav 2=241 (LC 7), 7=58 (LC 9), 8=423 (LC 17), 9=515 (LC 17), 10=352 (LC 17), 11=241 (LC 7)

FORCES

(lb) - Maximum Compression/Maximum Tension

TOP CHORD 1-2=0/16, 2-3=-408/282, 3-4=-309/223, 4-5=-238/169, 5-6=-271/296, 6-7=-229/242
 BOT CHORD 2-10=-175/191, 9-10=-175/191, 8-9=-175/191, 7-8=-175/191
 WEBS 5-8=-286/310, 4-9=-364/435, 3-10=-284/328

NOTES

- Unbalanced roof live loads have been considered for this design.
- Wind: ASCE 7-16; Vult=140mph (3-second gust) Vasd=108mph; TCDL=4.2psf; BCDL=5.0psf; h=25ft; Cat. II; Exp C; Enclosed; MWFRS (envelope) exterior zone and C-C Exterior(2E) 0-2-15 to 3-2-15, Interior (1) 3-2-15 to 7-3-0, Exterior(2R) 7-3-0 to 10-3-0, Exterior (2E) 10-3-0 to 11-1-9 zone; end vertical left and right exposed; C-C for members and forces & MWFRS for reactions shown; Lumber DOL=1.60 plate grip DOL=1.60

- Truss designed for wind loads in the plane of the truss only. For studs exposed to wind (normal to the face), see Standard Industry Gable End Details as applicable, or consult qualified building designer as per ANSI/TPI 1.
- Building Designer / Project engineer responsible for verifying applied roof live load shown covers rain loading requirements specific to the use of this truss component.
- Gable requires continuous bottom chord bearing.
- Gable studs spaced at 4'-0" oc.
- This truss has been designed for a 10.0 psf bottom chord live load nonconcurrent with any other live loads.
- * This truss has been designed for a live load of 20.0psf on the bottom chord in all areas where a rectangle 3'-06"-00 tall by 2'-00"-00 wide will fit between the bottom chord and any other members, with BCDL = 10.0psf.
- Provide mechanical connection (by others) of truss to bearing plate capable of withstanding 98 lb uplift at joint 7, 138 lb uplift at joint 2, 151 lb uplift at joint 8, 329 lb uplift at joint 9, 255 lb uplift at joint 10 and 138 lb uplift at joint 2.
- This truss design requires that a minimum of 7/16" structural wood sheathing be applied directly to the top chord and 1/2" gypsum sheetrock be applied directly to the bottom chord.
- See Standard Industry Piggyback Truss Connection Detail for Connection to base truss as applicable, or consult qualified building designer.

LOAD CASE(S) Standard

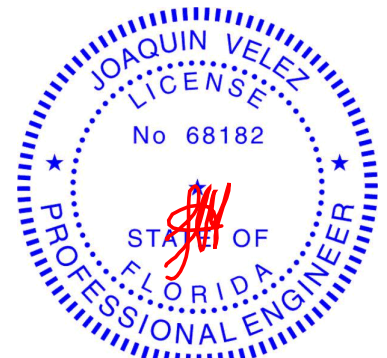

Joaquin Velez PE No.68182
 MiTek USA, Inc. FL Cert 6634
 6904 Parke East Blvd. Tampa FL 33610
 Date:

April 7, 2022

WARNING - Verify design parameters and READ NOTES ON THIS AND INCLUDED MITEK REFERENCE PAGE MII-7473 rev. 5/19/2020 BEFORE USE.

Design valid for use only with MiTek® connectors. This design is based only upon parameters shown, and is for an individual building component, not a truss system. Before use, the building designer must verify the applicability of design parameters and properly incorporate this design into the overall building design. Bracing indicated is to prevent buckling of individual truss web and/or chord members only. Additional temporary and permanent bracing is always required for stability and to prevent collapse with possible personal injury and property damage. For general guidance regarding the fabrication, storage, delivery, erection and bracing of trusses and truss systems, see ANSITPI1 Quality Criteria, DSB-89 and BCSI Building Component Safety Information available from Truss Plate Institute, 2670 Crain Highway, Suite 203 Waldorf, MD 20601



6904 Parke East Blvd.
 Tampa, FL 33610

Job 3039076	Truss PB06	Truss Type Piggyback	Qty 1	Ply 2	Job Reference (optional)	T27365446
----------------	---------------	-------------------------	----------	----------	--------------------------	-----------

Builders FirstSource (Groveland, FL), Groveland, FL - 34736,

Run: 8.53 S Jan 6 2022 Print: 8.530 S Jan 6 2022 MiTek Industries, Inc. Thu Apr 07 00:42:52

Page: 1

ID:fnk0JMssaXQH0W017dGQdzTRNc-YyMjJlIa2pRekf3PLIadn8ZFRWkYpc9iW5n7UQzTGgX

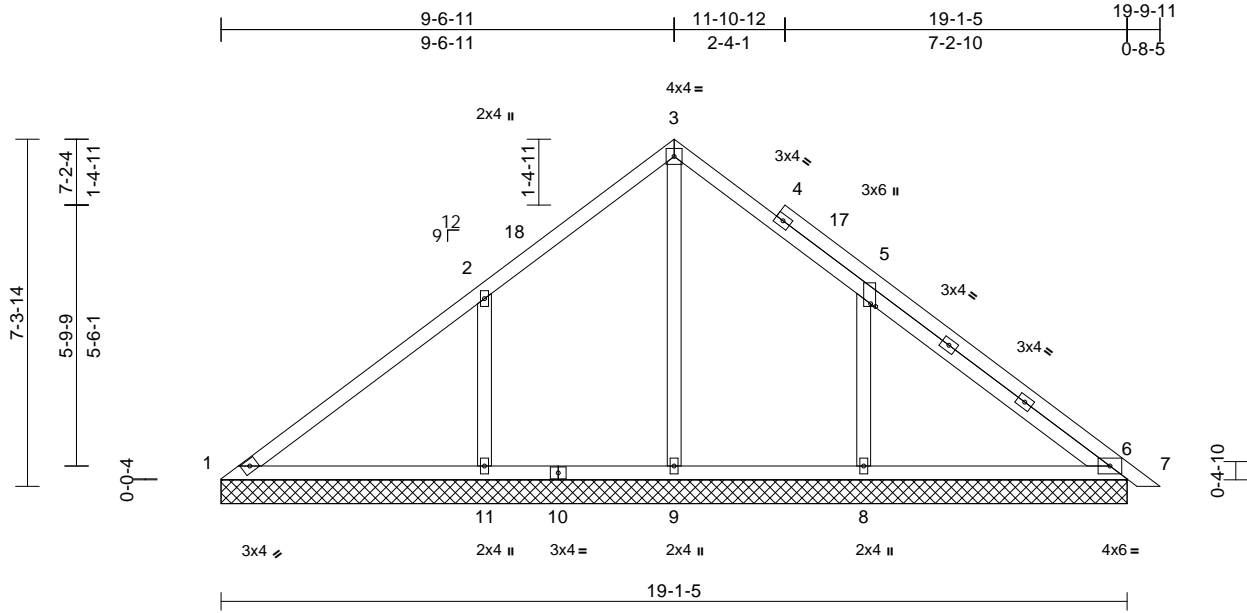

Scale = 1:48.6

Plate Offsets (X, Y): [5:0-0-11,0-1-4]

Loading	(psf)	Spacing	2-0-0	CSI	DEFL	in	(loc)	l/defl	L/d	PLATES	GRIP	
TCLL (roof)	20.0	Plate Grip DOL	1.25	TC	0.16	Vert(LL)	n/a	-	n/a	999	MT20	244/190
TCDL	10.0	Lumber DOL	1.25	BC	0.12	Vert(CT)	n/a	-	n/a	999		
BCLL	0.0*	Rep Stress Incr	YES	WB	0.07	Horz(CT)	0.00	6	n/a	n/a		
BCDL	10.0	Code	FBC2020/TPI2014	Matrix-AS							Weight: 196 lb	FT = 20%

LUMBER
TOP CHORD 2x4 SP No.2
BOT CHORD 2x4 SP No.2
OTHERS 2x4 SP No.3

BRACING
TOP CHORD Structural wood sheathing directly applied.
BOT CHORD Rigid ceiling directly applied.

REACTIONS All bearings 19-1-5.
(lb) - Max Horiz 1=276 (LC 8)
Max Uplift All uplift 100 (lb) or less at joint(s)
1, 6, 9, 14 except 8=443 (LC 11),
11=433 (LC 10)
Max Grav All reactions 250 (lb) or less at joint
(s) 1, 6, 14 except 8=685 (LC 18),
9=532 (LC 17), 11=669 (LC 17)

FORCES (lb) - Max. Comp./Max. Ten. - All forces 250
(lb) or less except when shown.
TOP CHORD 5-6=175/286, 1-2=271/378
BOT CHORD 1-11=-202/258, 10-11=-202/258,
9-10=-202/258, 8-9=-202/258, 6-8=-202/258

NOTES

- 2-ply truss to be connected together as follows:
Top chords connected with 10d (0.131"x3") nails as follows: 2x4 - 1 row at 0-9-0 oc.
Bottom chords connected with 10d (0.131"x3") nails as follows: 2x4 - 1 row at 0-9-0 oc.
- All loads are considered equally applied to all plies, except if noted as front (F) or back (B) face in the LOAD CASE(S) section. Ply to ply connections have been provided to distribute only loads noted as (F) or (B), unless otherwise indicated.
- Unbalanced roof live loads have been considered for this design.

- Wind: ASCE 7-16; Vult=140mph (3-second gust)
Vasd=108mph; TCCL=4.2psf; BCDL=5.0psf; h=25ft;
Cat. II; Exp C; Enclosed; MWFRS (envelope) exterior zone and C-C Exterior(2E) 0-8-5 to 3-8-5, Interior (1) 3-8-5 to 7-3-0, Exterior(2R) 7-3-0 to 13-3-0, Interior (1) 13-3-0 to 17-3-1, Exterior(2E) 17-3-1 to 20-3-1 zone; end vertical left and right exposed; C-C for members and forces & MWFRS for reactions shown; Lumber DOL=1.60 plate grip DOL=1.60
- Truss designed for wind loads in the plane of the truss only. For studs exposed to wind (normal to the face), see Standard Industry Gable End Details as applicable, or consult qualified building designer as per ANSI/TPI 1.
- Building Designer / Project engineer responsible for verifying applied roof live load shown covers rain loading requirements specific to the use of this truss component.
- Gable requires continuous bottom chord bearing.
- Gable studs spaced at 4-0-0 oc.
- This truss has been designed for a 10.0 psf bottom chord live load nonconcurrent with any other live loads.
- * This truss has been designed for a live load of 20.0psf on the bottom chord in all areas where a rectangle 3-06-00 tall by 2-00-00 wide will fit between the bottom chord and any other members, with BCDL = 10.0psf.
- Provide mechanical connection (by others) of truss to bearing plate capable of withstanding 100 lb uplift at joint(s) 1, 6, 9, 6 except (jt=lb) 11=432, 8=443.
- This truss design requires that a minimum of 7/16" structural wood sheathing be applied directly to the top chord and 1/2" gypsum sheetrock be applied directly to the bottom chord.
- See Standard Industry Piggyback Truss Connection Detail for Connection to base truss as applicable, or consult qualified building designer.

LOAD CASE(S) Standard

LATERALLY BRACE TOP CHORD WITH PURLINS AT 2-0-0 o/c IF STRUCTURAL SHEATHING IS NOT DIRECTLY APPLIED.

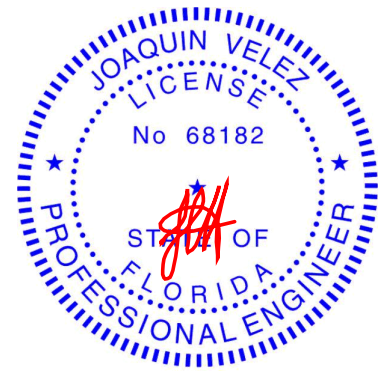

Joaquin Velez PE No.68182
MiTek USA, Inc. FL Cert 6634
6904 Parke East Blvd. Tampa FL 33610
Date:

April 7, 2022

WARNING - Verify design parameters and READ NOTES ON THIS AND INCLUDED MITEK REFERENCE PAGE MII-7473 rev. 5/19/2020 BEFORE USE.

Design valid for use only with MiTek® connectors. This design is based only upon parameters shown, and is for an individual building component, not a truss system. Before use, the building designer must verify the applicability of design parameters and properly incorporate this design into the overall building design. Bracing indicated is to prevent buckling of individual truss web and/or chord members only. Additional temporary and permanent bracing is always required for stability and to prevent collapse with possible personal injury and property damage. For general guidance regarding the fabrication, storage, delivery, erection and bracing of trusses and truss systems, see

ANSI/TPI1 Quality Criteria, DSB-89 and BCSI Building Component

Safety Information available from Truss Plate Institute, 2670 Crain Highway, Suite 203 Waldorf, MD 20601



6904 Parke East Blvd.
Tampa, FL 33610

Job 3039076	Truss PB07	Truss Type Piggyback	Qty 2	Ply 1	Job Reference (optional) T27365447
----------------	---------------	-------------------------	----------	----------	---------------------------------------

Builders FirstSource (Groveland, FL), Groveland, FL - 34736,

Run: 8.53 S Jan 6 2022 Print: 8.530 S Jan 6 2022 MiTek Industries, Inc. Thu Apr 07 00:43:26
ID:aegmb1VEI7BPJINTyud2a4zTnGw-YVPZSNiv1FjqpuFxLuBbAjz4NEXxN_1lLO0xgSzTGg?

Page: 1

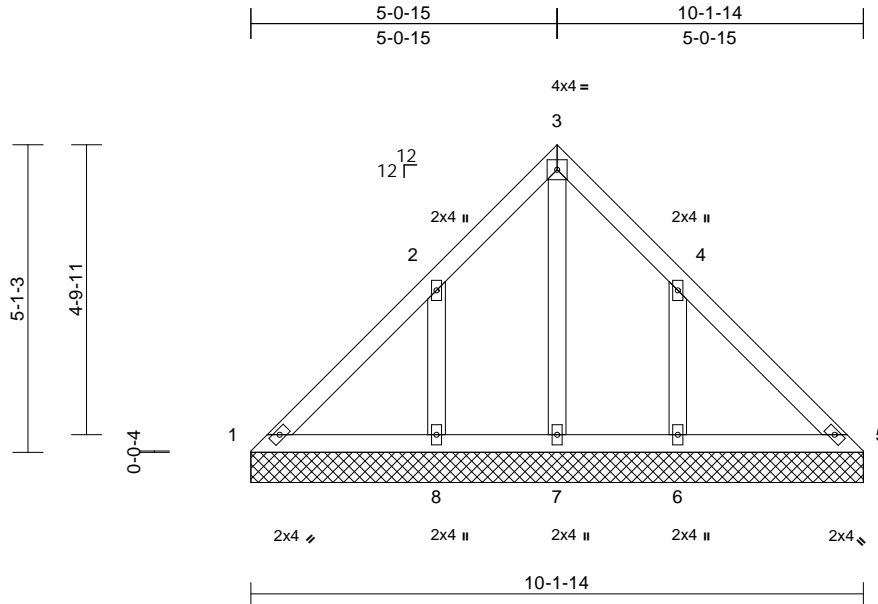

Scale = 1:38.2

Loading	(psf)	Spacing	2-0-0	CSI	DEFL	in	(loc)	l/defl	L/d	PLATES	GRIP	
TCLL (roof)	20.0	Plate Grip DOL	1.25	TC	0.13	Vert(LL)	n/a	-	n/a	999	MT20	244/190
TCDL	10.0	Lumber DOL	1.25	BC	0.12	Vert(TL)	n/a	-	n/a	999		
BCLL	0.0*	Rep Stress Incr	YES	WB	0.11	Horiz(TL)	0.00	5	n/a	n/a		
BCDL	10.0	Code	FBC2020/TPI2014	Matrix-MS							Weight: 49 lb	FT = 20%

LUMBER
TOP CHORD 2x4 SP No.2
BOT CHORD 2x4 SP No.2
OTHERS 2x4 SP No.3

BRACING
TOP CHORD Structural wood sheathing directly applied or 10-0-0 oc purlins.
BOT CHORD Rigid ceiling directly applied or 6-0-0 oc bracing.

REACTIONS All bearings 10-1-14.
(lb) - Max Horiz 1=189 (LC 7)
Max Uplift All uplift 100 (lb) or less at joint(s) 1 except 6=294 (LC 11), 8=301 (LC 10)
Max Grav All reactions 250 (lb) or less at joint (s) 1, 5, 7 except 6=318 (LC 18), 8=326 (LC 17)

FORCES (lb) - Max. Comp./Max. Ten. - All forces 250 (lb) or less except when shown.

WEBS 2-8=-273/362, 4-6=-273/362

NOTES

- Unbalanced roof live loads have been considered for this design.
- Wind: ASCE 7-16; Vult=140mph (3-second gust) Vasd=108mph; TCDL=4.2psf; BCDL=5.0psf; h=25ft; Cat. II; Exp C; Enclosed; MWFRS (envelope) exterior zone and C-C Exterior(2E) 0-6-13 to 3-7-12, Exterior (2R) 3-7-12 to 7-7-12, Exterior(2E) 7-7-12 to 10-8-11 zone; end vertical left and right exposed; C-C for members and forces & MWFRS for reactions shown; Lumber DOL=1.60 plate grip DOL=1.60
- Truss designed for wind loads in the plane of the truss only. For studs exposed to wind (normal to the face), see Standard Industry Gable End Details as applicable, or consult qualified building designer as per ANSI/TPI 1.
- Building Designer / Project engineer responsible for verifying applied roof live load shown covers rain loading requirements specific to the use of this truss component.

- Gable requires continuous bottom chord bearing.
- Gable studs spaced at 4-0-0 oc.
- This truss has been designed for a 10.0 psf bottom chord live load nonconcurrent with any other live loads.
- * This truss has been designed for a live load of 20.0psf on the bottom chord in all areas where a rectangle 3-06-00 tall by 2-00-00 wide will fit between the bottom chord and any other members.
- Provide mechanical connection (by others) of truss to bearing plate capable of withstanding 100 lb uplift at joint(s) 1 except (jt=lb) 8=301, 6=294.
- See Standard Industry Piggyback Truss Connection Detail for Connection to base truss as applicable, or consult qualified building designer.

LOAD CASE(S) Standard

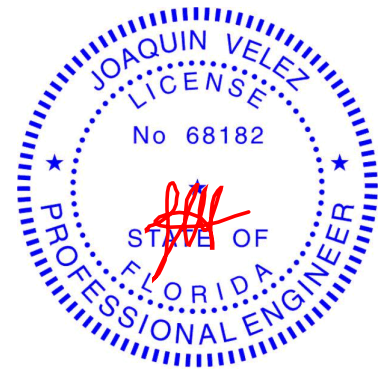

Joaquin Velez PE No.68182
MiTek USA, Inc. FL Cert 6634
6904 Parke East Blvd. Tampa FL 33610
Date:

April 7, 2022

WARNING - Verify design parameters and READ NOTES ON THIS AND INCLUDED MITEK REFERENCE PAGE MII-7473 rev. 5/19/2020 BEFORE USE.

Design valid for use only with MiTek® connectors. This design is based only upon parameters shown, and is for an individual building component, not a truss system. Before use, the building designer must verify the applicability of design parameters and properly incorporate this design into the overall building design. Bracing indicated is to prevent buckling of individual truss web and/or chord members only. Additional temporary and permanent bracing is always required for stability and to prevent collapse with possible personal injury and property damage. For general guidance regarding the fabrication, storage, delivery, erection and bracing of trusses and truss systems, see

ANSI/TPI1 Quality Criteria, DSB-89 and BCSI Building Component

Safety Information available from Truss Plate Institute, 2670 Crain Highway, Suite 203 Waldorf, MD 20601



6904 Parke East Blvd.
Tampa, FL 36610

Job 3039076	Truss PB08	Truss Type Piggyback	Qty 33	Ply 1	Job Reference (optional) T27365448
----------------	---------------	-------------------------	-----------	----------	---------------------------------------

Builders FirstSource (Groveland, FL), Groveland, FL - 34736,

Run: 8.53 S Dec 6 2021 Print: 8.530 S Dec 6 2021 MiTek Industries, Inc. Wed Apr 06 15:10:12
ID:8yxO6g7MHWnXXrg9m8z_HfzTn6-RfC?PsB70Hq3NSgPqnL8w3uTXbGKwRCDoi7J4zJC?

Page: 1

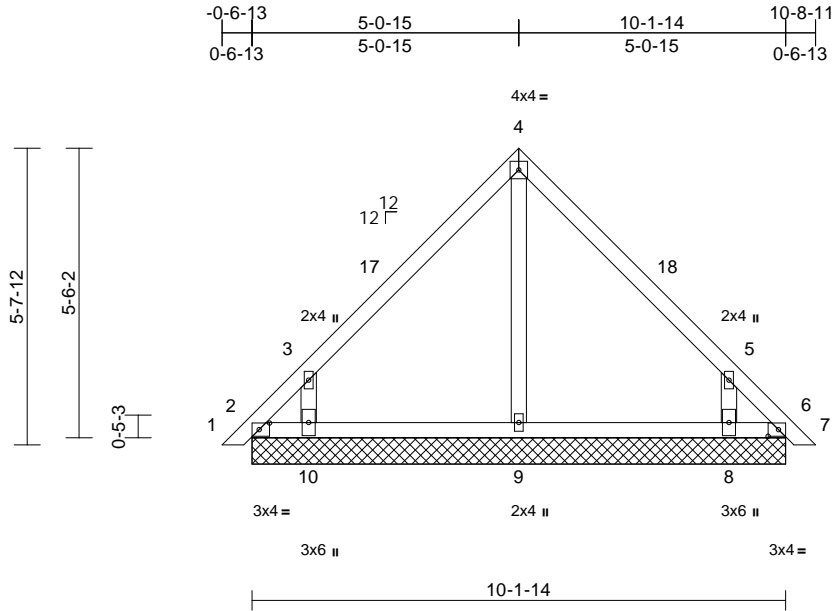

Scale = 1:43.9

Plate Offsets (X, Y): [2:0-2-6,0-1-8], [6:0-2-6,0-1-8]

Loading	(psf)	Spacing	2-0-0	CSI	DEFL	in	(loc)	l/defl	L/d	PLATES	GRIP	
TCLL (roof)	20.0	Plate Grip DOL	1.25	TC	0.33	Vert(LL)	n/a	-	n/a	999	MT20	244/190
TCDL	10.0	Lumber DOL	1.25	BC	0.12	Vert(CT)	n/a	-	n/a	999		
BCLL	0.0*	Rep Stress Incr	YES	WB	0.19	Horz(CT)	0.00	14	n/a	n/a		
BCDL	10.0	Code	FBC2020/TPI2014	Matrix-MS							Weight: 49 lb	FT = 20%

LUMBER

TOP CHORD 2x4 SP No.2
BOT CHORD 2x4 SP No.2
OTHERS 2x4 SP No.3

BRACING

TOP CHORD Structural wood sheathing directly applied or 6-0-0 oc purlins.
BOT CHORD Rigid ceiling directly applied or 10-0-0 oc bracing.

REACTIONS

(lb/size) 2=23/10-1-14, 6=23/10-1-14, 8=291/10-1-14, 9=227/10-1-14, 10=291/10-1-14, 11=23/10-1-14, 14=23/10-1-14
Max Horiz 2=-211 (LC 8), 11=-211 (LC 8)
Max Uplift 2=-161 (LC 8), 6=-123 (LC 9), 8=-419 (LC 11), 10=-421 (LC 10), 11=-161 (LC 8), 14=-123 (LC 9)
Max Grav 2=229 (LC 10), 6=203 (LC 11), 8=400 (LC 18), 9=231 (LC 17), 10=402 (LC 17), 11=229 (LC 10), 14=203 (LC 11)

FORCES

(lb) - Maximum Compression/Maximum Tension

TOP CHORD 1-2=0/15, 2-3=-327/225, 3-4=-179/183, 4-5=-149/183, 5-6=-293/178, 6-7=0/15
BOT CHORD 2-10=-77/156, 9-10=-77/156, 8-9=-77/156, 6-8=-77/156
WEBS 4-9=-144/41, 3-10=-447/631, 5-8=-447/631

NOTES

1) Unbalanced roof live loads have been considered for this design.

- Wind: ASCE 7-16; Vult=140mph (3-second gust) Vasd=108mph; TCDL=4.2psf; BCDL=5.0psf; h=25ft; Cat. II; Exp C; Enclosed; MWFRS (envelope) exterior zone and C-C Exterior(2E) 0-2-8 to 3-2-8, Exterior(2R) 3-2-8 to 8-1-0, Exterior(2E) 8-1-0 to 11-1-0 zone; end vertical left and right exposed; C-C for members and forces & MWFRS for reactions shown; Lumber DOL=1.60 plate grip DOL=1.60
- Truss designed for wind loads in the plane of the truss only. For studs exposed to wind (normal to the face), see Standard Industry Gable End Details as applicable, or consult qualified building designer as per ANSI/TPI 1.
- Building Designer / Project engineer responsible for verifying applied roof live load shown covers rain loading requirements specific to the use of this truss component.
- Gable requires continuous bottom chord bearing.
- Gable studs spaced at 4-0-0 oc.
- This truss has been designed for a 10.0 psf bottom chord live load nonconcurrent with any other live loads.
- * This truss has been designed for a live load of 20.0psf on the bottom chord in all areas where a rectangle 3-06-00 tall by 2-00-00 wide will fit between the bottom chord and any other members.
- Provide mechanical connection (by others) of truss to bearing plate capable of withstanding 161 lb uplift at joint 2, 123 lb uplift at joint 6, 421 lb uplift at joint 10, 419 lb uplift at joint 8, 161 lb uplift at joint 2 and 123 lb uplift at joint 6.
- See Standard Industry Piggyback Truss Connection Detail for Connection to base truss as applicable, or consult qualified building designer.

LOAD CASE(S) Standard

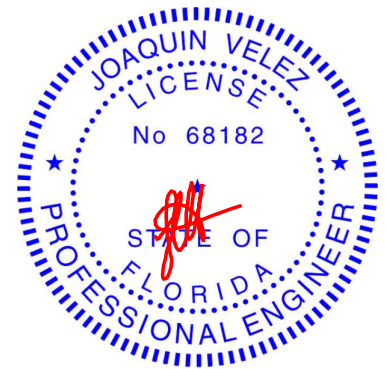

Joaquin Velez PE No.68182
MiTek USA, Inc. FL Cert 6634
6904 Parke East Blvd. Tampa FL 33610
Date:

April 7, 2022

WARNING - Verify design parameters and READ NOTES ON THIS AND INCLUDED MITEK REFERENCE PAGE MII-7473 rev. 5/19/2020 BEFORE USE.

Design valid for use only with MiTek® connectors. This design is based only upon parameters shown, and is for an individual building component, not a truss system. Before use, the building designer must verify the applicability of design parameters and properly incorporate this design into the overall building design. Bracing indicated is to prevent buckling of individual truss web and/or chord members only. Additional temporary and permanent bracing is always required for stability and to prevent collapse with possible personal injury and property damage. For general guidance regarding the fabrication, storage, delivery, erection and bracing of trusses and truss systems, see **ANSI/TPI1 Quality Criteria, DSB-89 and BCSI Building Component Safety Information** available from Truss Plate Institute, 2670 Crain Highway, Suite 203 Waldorf, MD 20601



6904 Parke East Blvd.
Tampa, FL 33610

Job 3039076	Truss PB09	Truss Type Piggyback	Qty 1	Ply 1	Job Reference (optional)	T27365449
----------------	---------------	-------------------------	----------	----------	--------------------------	-----------

Builders FirstSource (Groveland, FL), Groveland, FL - 34736,

Run: 8.53 S Dec 6 2021 Print: 8.530 S Dec 6 2021 MiTek Industries, Inc. Wed Apr 06 15:10:12
ID:mNJGoe4uAlotgWfFmVQIRszTUDN-RfC?PsB70Hq3NSgPqnL8w3uITXbGKwRCDoi7J4zJC?f

Page: 1

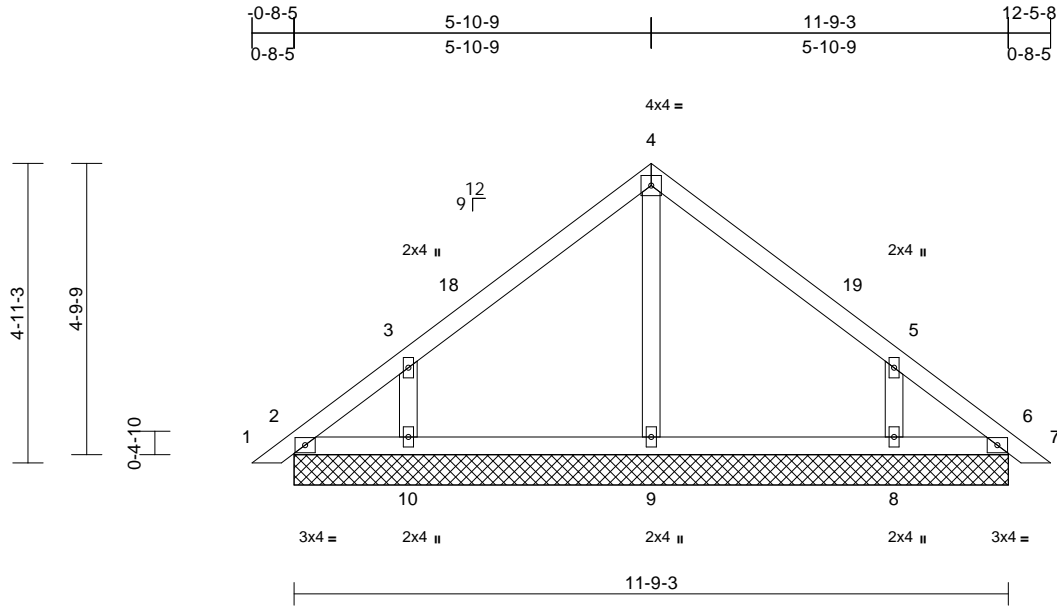

Scale = 1:37.9

Loading	(psf)	Spacing	2-0-0	CSI	DEFL	in	(loc)	l/defl	L/d	PLATES	GRIP	
TCLL (roof)	20.0	Plate Grip DOL	1.25	TC	0.18	Vert(LL)	n/a	-	n/a	999	MT20	244/190
TCDL	10.0	Lumber DOL	1.25	BC	0.12	Vert(CT)	n/a	-	n/a	999		
BCLL	0.0*	Rep Stress Incr	YES	WB	0.10	Horz(CT)	0.00	15	n/a	n/a		
BCDL	10.0	Code	FBC2020/TPI2014	Matrix-AS							Weight: 52 lb	FT = 20%

LUMBER

TOP CHORD 2x4 SP No.2
BOT CHORD 2x4 SP No.2
OTHERS 2x4 SP No.3

BRACING

TOP CHORD Structural wood sheathing directly applied.
BOT CHORD Rigid ceiling directly applied.

REACTIONS

(lb/size) 2=92/11-9-3, 6=92/11-9-3,
8=274/11-9-3, 9=264/11-9-3,
10=274/11-9-3, 11=92/11-9-3,
15=92/11-9-3
Max Horiz 2=-184 (LC 8), 11=-184 (LC 8)
Max Uplift 2=-68 (LC 6), 6=-33 (LC 7), 8=-280
(LC 11), 9=-15 (LC 10), 10=-281
(LC 10), 11=-68 (LC 6), 15=-33 (LC
7)
Max Grav 2=127 (LC 18), 6=99 (LC 17),
8=342 (LC 18), 9=264 (LC 1),
10=344 (LC 17), 11=127 (LC 18),
15=99 (LC 17)

FORCES

(lb) - Maximum Compression/Maximum
Tension
TOP CHORD 1-2=0/16, 2-3=-157/141, 3-4=-150/161,
4-5=-125/161, 5-6=-109/82, 6-7=0/16
BOT CHORD 2-10=-56/116, 9-10=-56/116, 8-9=-56/116,
6-8=-56/116
WEBS 4-9=-178/64, 3-10=-294/341, 5-8=-294/341

NOTES

- 1) Unbalanced roof live loads have been considered for this design.
- 2) Wind: ASCE 7-16; Vult=140mph (3-second gust)
Vasd=108mph; TCDL=4.2psf; BCDL=5.0psf; h=25ft;
Cat. II; Exp C; Enclosed; MWFRS (envelope) exterior zone and C-C Exterior(2E) 0-2-15 to 3-2-15, Interior (1) 3-2-15 to 3-6-15, Exterior(2R) 3-6-15 to 9-6-15, Interior (1) 9-6-15 to 9-10-15, Exterior(2E) 9-10-15 to 12-10-15 zone; end vertical left and right exposed; C-C for members and forces & MWFRS for reactions shown; Lumber DOL=1.60 plate grip DOL=1.60

- 3) Truss designed for wind loads in the plane of the truss only. For studs exposed to wind (normal to the face), see Standard Industry Gable End Details as applicable, or consult qualified building designer as per ANSI/TPI 1.
- 4) Building Designer / Project engineer responsible for verifying applied roof live load shown covers rain loading requirements specific to the use of this truss component.
- 5) Gable requires continuous bottom chord bearing.
- 6) Gable studs spaced at 4'-0" oc.
- 7) This truss has been designed for a 10.0 psf bottom chord live load nonconcurrent with any other live loads.
- 8) * This truss has been designed for a live load of 20.0psf on the bottom chord in all areas where a rectangle 3'-0"-0" tall by 2'-0"-0" wide will fit between the bottom chord and any other members.
- 9) Provide mechanical connection (by others) of truss to bearing plate capable of withstanding 68 lb uplift at joint 2, 33 lb uplift at joint 6, 15 lb uplift at joint 9, 281 lb uplift at joint 10, 280 lb uplift at joint 8, 68 lb uplift at joint 2 and 33 lb uplift at joint 6.
- 10) This truss design requires that a minimum of 7/16" structural wood sheathing be applied directly to the top chord and 1/2" gypsum sheetrock be applied directly to the bottom chord.
- 11) See Standard Industry Piggyback Truss Connection Detail for Connection to base truss as applicable, or consult qualified building designer.

LOAD CASE(S) Standard

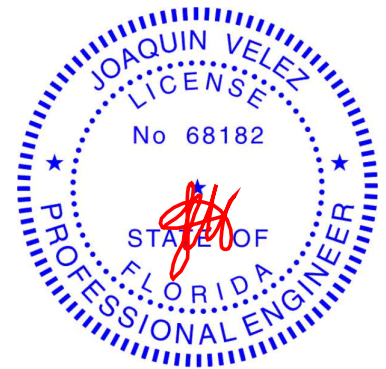

Joaquin Velez PE No.68182
MiTek USA, Inc. FL Cert 6634
6904 Parke East Blvd. Tampa FL 33610
Date:

April 7, 2022

WARNING - Verify design parameters and READ NOTES ON THIS AND INCLUDED MITEK REFERENCE PAGE MII-7473 rev. 5/19/2020 BEFORE USE.

Design valid for use only with MiTek® connectors. This design is based only upon parameters shown, and is for an individual building component, not a truss system. Before use, the building designer must verify the applicability of design parameters and properly incorporate this design into the overall building design. Bracing indicated is to prevent buckling of individual truss web and/or chord members only. Additional temporary and permanent bracing is always required for stability and to prevent collapse with possible personal injury and property damage. For general guidance regarding the fabrication, storage, delivery, erection and bracing of trusses and truss systems, see

ANSI/TPI1 Quality Criteria, DSB-89 and BCSI Building Component

Safety Information available from Truss Plate Institute, 2670 Crain Highway, Suite 203 Waldorf, MD 20601



6904 Parke East Blvd.
Tampa, FL 33610

Job 3039076	Truss PB10	Truss Type Piggyback	Qty 1	Ply 1	Job Reference (optional) T27365450
----------------	---------------	-------------------------	----------	----------	---------------------------------------

Builders FirstSource (Groveland, FL), Groveland, FL - 34736,

Run: 8:53 S Jan 6 2022 Print: 8:530 S Jan 6 2022 MiTek Industries, Inc. Thu Apr 07 00:43:50
ID:I6SUS06?WIOOy4WnKXegbQzTShC-r6seUa?yNdlQiaUzIxcD8NzBjv78PrzFs7qCW3zTGfd

Page: 1

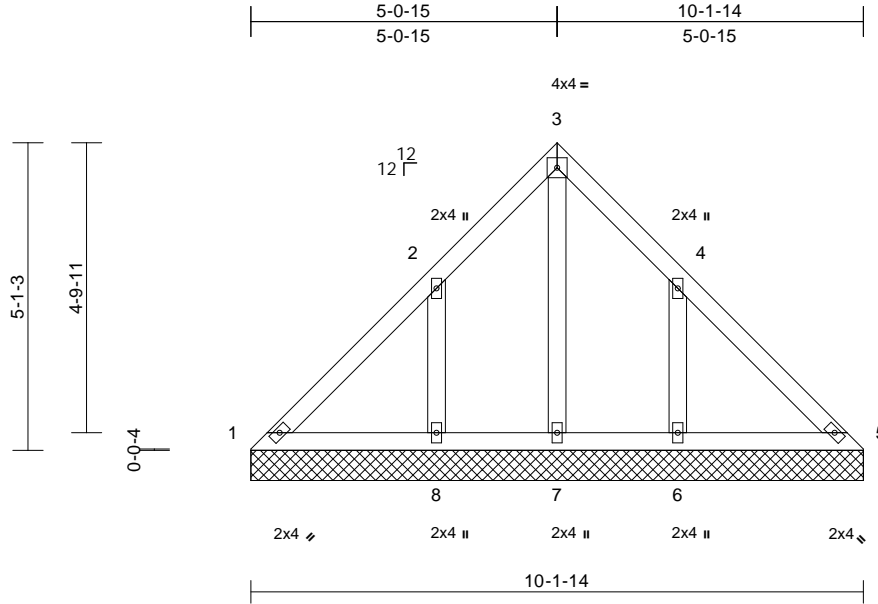

Scale = 1:38.2

Loading	(psf)	Spacing	2-0-0	CSI	DEFL	in	(loc)	l/defl	L/d	PLATES	GRIP	
TCLL (roof)	20.0	Plate Grip DOL	1.25	TC	0.13	Vert(LL)	n/a	-	n/a	999	MT20	244/190
TCDL	10.0	Lumber DOL	1.25	BC	0.12	Vert(TL)	n/a	-	n/a	999		
BCLL	0.0*	Rep Stress Incr	YES	WB	0.11	Horiz(TL)	0.00	5	n/a	n/a		
BCDL	10.0	Code	FBC2020/TPI2014	Matrix-MS							Weight: 49 lb	FT = 20%

LUMBER

- TOP CHORD 2x4 SP No.2
- BOT CHORD 2x4 SP No.2
- OTHERS 2x4 SP No.3

BRACING

- TOP CHORD Structural wood sheathing directly applied or 10-0-0 oc purlins.
- BOT CHORD Rigid ceiling directly applied or 6-0-0 oc bracing.

REACTIONS

- All bearings 10-1-14.
- (lb) - Max Horiz 1--189 (LC 8)
- Max Uplift All uplift 100 (lb) or less at joint(s) 1 except 6--294 (LC 11), 8--301 (LC 10)
- Max Grav All reactions 250 (lb) or less at joint (s) 1, 5, 7 except 6--318 (LC 18), 8--326 (LC 17)

FORCES

- (lb) - Max. Comp./Max. Ten. - All forces 250
- (lb) or less except when shown.

WEBS

- 2-8--273/362, 4-6--273/362

NOTES

- Unbalanced roof live loads have been considered for this design.
- Wind: ASCE 7-16; Vult=140mph (3-second gust) Vasd=108mph; TC DL=4.2psf; BC DL=5.0psf; h=25ft; Cat. II; Exp C; Enclosed; MWFRS (envelope) exterior zone and C-C Exterior(2E) 0-6-13 to 3-7-12, Exterior (2R) 3-7-12 to 7-7-12, Exterior(2E) 7-7-12 to 10-8-11 zone; end vertical left and right exposed; C-C for members and forces & MWFRS for reactions shown; Lumber DOL=1.60 plate grip DOL=1.60
- Truss designed for wind loads in the plane of the truss only. For studs exposed to wind (normal to the face), see Standard Industry Gable End Details as applicable, or consult qualified building designer as per ANSI/TPI 1.
- Building Designer / Project engineer responsible for verifying applied roof live load shown covers rain loading requirements specific to the use of this truss component.

- Gable requires continuous bottom chord bearing.
- Gable studs spaced at 2-0-0 oc.
- This truss has been designed for a 10.0 psf bottom chord live load nonconcurrent with any other live loads.
- * This truss has been designed for a live load of 20.0psf on the bottom chord in all areas where a rectangle 3-06-00 tall by 2-00-00 wide will fit between the bottom chord and any other members.
- Provide mechanical connection (by others) of truss to bearing plate capable of withstanding 100 lb uplift at joint(s) 1 except (jt=lb) 8=301, 6=294.
- See Standard Industry Piggyback Truss Connection Detail for Connection to base truss as applicable, or consult qualified building designer.

LOAD CASE(S) Standard

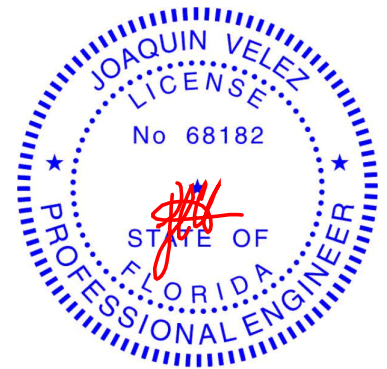

Joaquin Velez PE No.68182
MiTek USA, Inc. FL Cert 6634
6904 Parke East Blvd. Tampa FL 33610
Date:

April 7, 2022

WARNING - Verify design parameters and READ NOTES ON THIS AND INCLUDED MITEK REFERENCE PAGE MII-7473 rev. 5/19/2020 BEFORE USE.

Design valid for use only with MiTek® connectors. This design is based only upon parameters shown, and is for an individual building component, not a truss system. Before use, the building designer must verify the applicability of design parameters and properly incorporate this design into the overall building design. Bracing indicated is to prevent buckling of individual truss web and/or chord members only. Additional temporary and permanent bracing is always required for stability and to prevent collapse with possible personal injury and property damage. For general guidance regarding the fabrication, storage, delivery, erection and bracing of trusses and truss systems, see **ANSI/TPI1 Quality Criteria, DSB-89 and BCSI Building Component Safety Information** available from Truss Plate Institute, 2670 Crain Highway, Suite 203 Waldorf, MD 20601



6904 Parke East Blvd.
Tampa, FL 36610

Job 3039076	Truss V02	Truss Type Valley	Qty 1	Ply 1	Job Reference (optional)	T27365452
----------------	--------------	----------------------	----------	----------	--------------------------	-----------

Builders FirstSource (Groveland, FL), Groveland, FL - 34736,

Run: 8.53 S Dec 6 2021 Print: 8.530 S Dec 6 2021 MiTek Industries, Inc. Wed Apr 06 15:10:13
ID:Je0TgCaSioGHAN7Igr9RVPzTkHk-RfC?PsB70Hq3NSgPqnL8w3uITxbGKwRCDoi7J4zJC?F

Page: 1

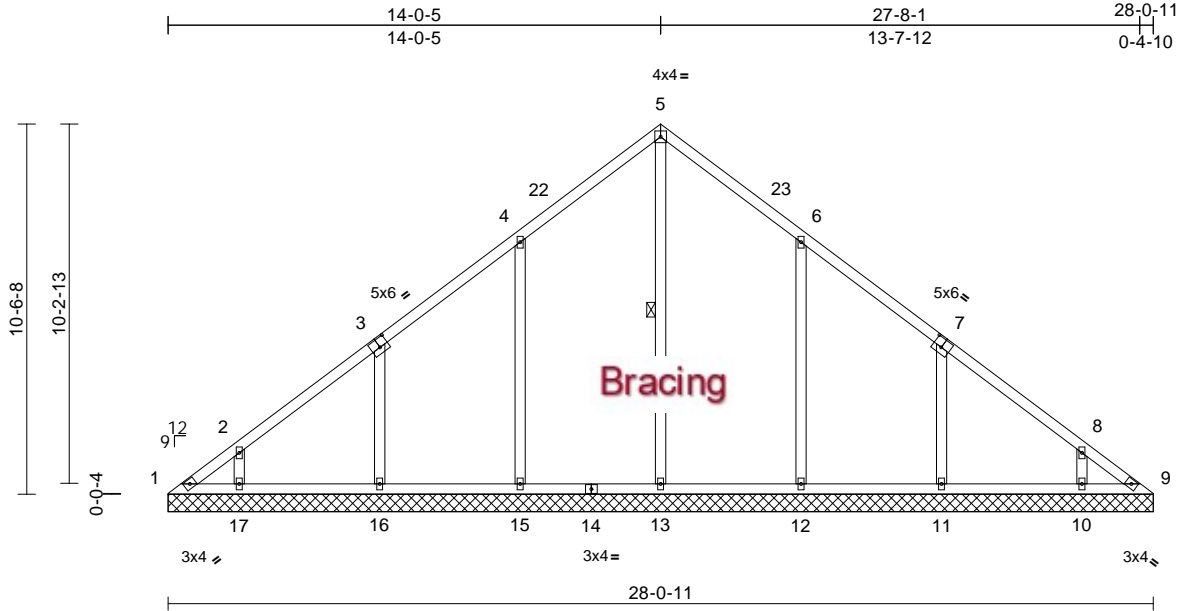

Scale = 1:65.6

Plate Offsets (X, Y): [3:0-3:0,0-3:0], [7:0-3:0,0-3:0]

Loading	(psf)	Spacing	2-0-0	CSI	DEFL	in	(loc)	l/defl	L/d	PLATES	GRIP	
TCLL (roof)	20.0	Plate Grip DOL	1.25	TC	0.21	Vert(LL)	n/a	-	n/a	999	MT20	244/190
TCDL	10.0	Lumber DOL	1.25	BC	0.17	Vert(TL)	n/a	-	n/a	999		
BCLL	0.0*	Rep Stress Incr	YES	WB	0.32	Horiz(TL)	0.01	9	n/a	n/a		
BCDL	10.0	Code	FBC2020/TPI2014	Matrix-AS							Weight: 143 lb	FT = 20%

LUMBER

TOP CHORD 2x4 SP No.2
BOT CHORD 2x4 SP No.2
OTHERS 2x4 SP No.3

BRACING

TOP CHORD Structural wood sheathing directly applied.
BOT CHORD Rigid ceiling directly applied.
WEBS 1 Row at midpt 5-13

REACTIONS (lb/size)
1=65/28-0-11, 9=65/28-0-11,
10=276/28-0-11, 11=324/28-0-11,
12=330/28-0-11, 13=255/28-0-11,
15=330/28-0-11, 16=324/28-0-11,
17=276/28-0-11
Max Horiz 1=-401 (LC 8)
Max Uplift 1=-139 (LC 8), 9=44 (LC 9),
10=-196 (LC 11), 11=-313 (LC 11),
12=-321 (LC 11), 15=-322 (LC 10),
16=-312 (LC 10), 17=-207 (LC 10)
Max Grav 1=199 (LC 7), 9=130 (LC 11),
10=347 (LC 18), 11=480 (LC 18),
12=525 (LC 18), 13=463 (LC 20),
15=527 (LC 17), 16=479 (LC 17),
17=359 (LC 17)

FORCES (lb) - Maximum Compression/Maximum Tension

TOP CHORD 1-2=-421/319, 2-4=-287/261, 4-5=-241/359,
5-6=-241/320, 6-8=-187/141, 8-9=-328/181
BOT CHORD 1-17=-165/291, 16-17=-145/291,
15-16=-145/294, 13-15=-145/294,
12-13=-145/294, 11-12=-145/294,
10-11=-141/288, 9-10=-141/288
WEBS 5-13=-265/58, 4-15=-324/363,
3-16=-304/350, 2-17=-250/271,
6-12=-322/361, 7-11=-305/351,
8-10=-245/266

NOTES

1) Unbalanced roof live loads have been considered for this design.

- 2) Wind: ASCE 7-16; Vult=140mph (3-second gust)
Vasd=108mph; TCDL=4.2psf; BCDL=5.0psf; h=25ft;
Cat. II; Exp C; Enclosed; MWFRS (envelope) exterior zone and C-C Exterior(2E) 0-0-5 to 3-0-5, Interior (1) 3-0-5 to 11-0-11, Exterior(2R) 11-0-11 to 17-0-11, Interior (1) 17-0-11 to 25-1-0, Exterior(2E) 25-1-0 to 28-1-0 zone; end vertical left and right exposed; C-C for members and forces & MWFRS for reactions shown; Lumber DOL=1.60 plate grip DOL=1.60
- 3) Truss designed for wind loads in the plane of the truss only. For studs exposed to wind (normal to the face), see Standard Industry Gable End Details as applicable, or consult qualified building designer as per ANSI/TPI 1.
- 4) Building Designer / Project engineer responsible for verifying applied roof live load shown covers rain loading requirements specific to the use of this truss component.
- 5) All plates are 2x4 MT20 unless otherwise indicated.
- 6) Gable requires continuous bottom chord bearing.
- 7) Gable studs spaced at 4-0-0 oc.
- 8) This truss has been designed for a 10.0 psf bottom chord live load nonconcurrent with any other live loads.
- 9) * This truss has been designed for a live load of 20.0psf on the bottom chord in all areas where a rectangle 3-06-00 tall by 2-00-00 wide will fit between the bottom chord and any other members, with BCDL = 10.0psf.
- 10) Provide mechanical connection (by others) of truss to bearing plate capable of withstanding 139 lb uplift at joint 1, 322 lb uplift at joint 15, 312 lb uplift at joint 16, 207 lb uplift at joint 17, 321 lb uplift at joint 12, 313 lb uplift at joint 11, 196 lb uplift at joint 10 and 44 lb uplift at joint 9.
- 11) This truss design requires that a minimum of 7/16" structural wood sheathing be applied directly to the top chord and 1/2" gypsum sheetrock be applied directly to the bottom chord.

LOAD CASE(S) Standard

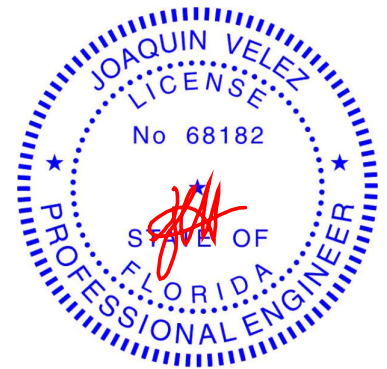

Joaquin Velez PE No.68182
MiTek USA, Inc. FL Cert 6634
6904 Parke East Blvd. Tampa FL 33610
Date:

April 7, 2022

WARNING - Verify design parameters and READ NOTES ON THIS AND INCLUDED MITEK REFERENCE PAGE MII-7473 rev. 5/19/2020 BEFORE USE.

Design valid for use only with MiTek® connectors. This design is based only upon parameters shown, and is for an individual building component, not a truss system. Before use, the building designer must verify the applicability of design parameters and properly incorporate this design into the overall building design. Bracing indicated is to prevent buckling of individual truss web and/or chord members only. Additional temporary and permanent bracing is always required for stability and to prevent collapse with possible personal injury and property damage. For general guidance regarding the fabrication, storage, delivery, erection and bracing of trusses and truss systems, see

ANSI/TPI1 Quality Criteria, DSB-89 and BCSI Building Component

Safety Information available from Truss Plate Institute, 2670 Crain Highway, Suite 203 Waldorf, MD 20601



6904 Parke East Blvd.
Tampa, FL 33610

Job 3039076	Truss V03	Truss Type Valley	Qty 1	Ply 1	Job Reference (optional)	T27365453
----------------	--------------	----------------------	----------	----------	--------------------------	-----------

Builders FirstSource (Groveland, FL), Groveland, FL - 34736,

Run: 8.53 S Dec 6 2021 Print: 8.530 S Dec 6 2021 MiTek Industries, Inc. Wed Apr 06 15:10:14
ID:Je0TgCaSioeGHAn7lg9RVPzTKHk-RfC?PsB70Hq3NSgPqnL8w3ulTXbGKWrCDoi7J4zJC?f

Page: 1

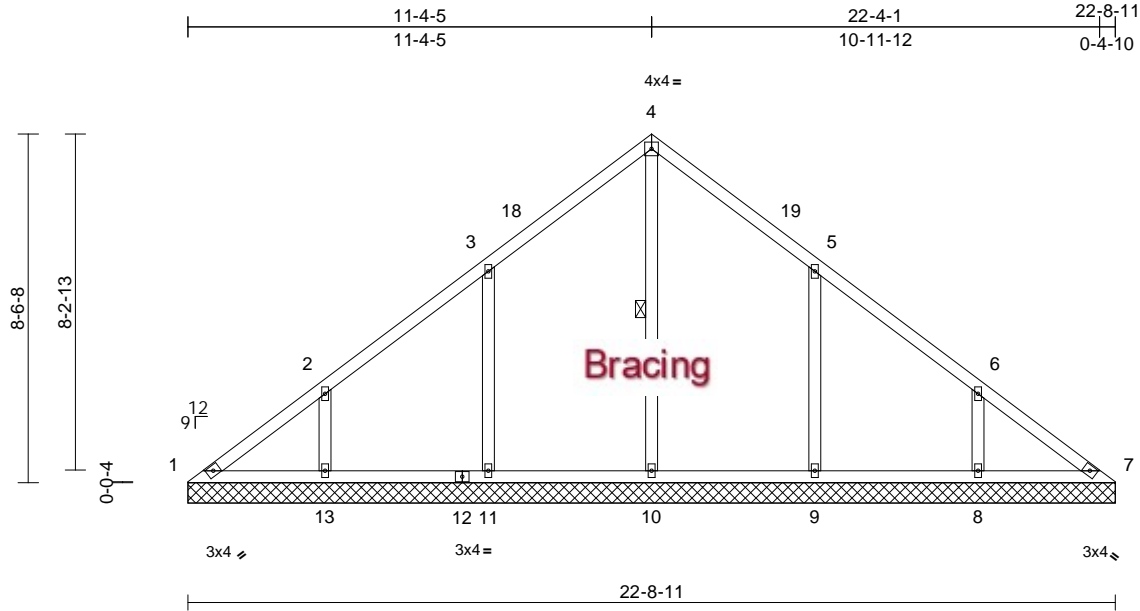

Scale = 1:56.5

Loading	(psf)	Spacing	2-0-0	CSI	DEFL	in	(loc)	l/defl	L/d	PLATES	GRIP	
TCLL (roof)	20.0	Plate Grip DOL	1.25	TC	0.20	Vert(LL)	n/a	-	n/a	999	MT20	244/190
TCDL	10.0	Lumber DOL	1.25	BC	0.17	Vert(TL)	n/a	-	n/a	999		
BCLL	0.0*	Rep Stress Incr	YES	WB	0.17	Horiz(TL)	0.01	7	n/a	n/a		
BCDL	10.0	Code	FBC2020/TPI2014	Matrix-AS							Weight: 107 lb	FT = 20%

LUMBER

TOP CHORD 2x4 SP No.2
BOT CHORD 2x4 SP No.2
OTHERS 2x4 SP No.3

BRACING

TOP CHORD Structural wood sheathing directly applied.
BOT CHORD Rigid ceiling directly applied.
WEBS 1 Row at midpt 4-10

REACTIONS (lb/size) 1=105/22-8-11, 7=105/22-8-11, 8=326/22-8-11, 9=328/22-8-11, 10=301/22-8-11, 11=328/22-8-11, 13=326/22-8-11
Max Horiz 1=-324 (LC 6)
Max Uplift 1=-85 (LC 6), 7=-10 (LC 7), 8=-274 (LC 11), 9=-328 (LC 11), 11=-327 (LC 10), 13=-280 (LC 10)
Max Grav 1=181 (LC 18), 7=124 (LC 17), 8=428 (LC 18), 9=492 (LC 18), 10=467 (LC 20), 11=492 (LC 17), 13=434 (LC 17)

FORCES (lb) - Maximum Compression/Maximum Tension

TOP CHORD 1-2=-295/268, 2-3=-184/197, 3-4=-165/277, 4-5=-165/239, 5-6=-98/105, 6-7=-217/154
BOT CHORD 1-13=-128/240, 11-13=-128/240, 10-11=-128/240, 9-10=-128/240, 8-9=-128/240, 7-8=-128/240
WEBS 4-10=-259/11, 3-11=-326/371, 2-13=-284/303, 5-9=-325/371, 6-8=-281/301

NOTES

1) Unbalanced roof live loads have been considered for this design.

- Wind: ASCE 7-16; Vult=140mph (3-second gust) Vasd=108mph; TC DL=4.2psf; BCDL=5.0psf; h=25ft; Cat. II; Exp C; Enclosed; MWFRS (envelope) exterior zone and C-C Exterior(2E) 0-0-5 to 3-0-5, Interior (1) 3-0-5 to 8-4-11, Exterior(2R) 8-4-11 to 14-4-11, Interior (1) 14-4-11 to 19-9-0, Exterior(2E) 19-9-0 to 22-9-0 zone; end vertical left and right exposed; C-C for members and forces & MWFRS for reactions shown; Lumber DOL=1.60 plate grip DOL=1.60
- Truss designed for wind loads in the plane of the truss only. For studs exposed to wind (normal to the face), see Standard Industry Gable End Details as applicable, or consult qualified building designer as per ANSI/TPI 1.
- Building Designer / Project engineer responsible for verifying applied roof live load shown covers rain loading requirements specific to the use of this truss component.
- All plates are 2x4 MT20 unless otherwise indicated.
- Gable requires continuous bottom chord bearing.
- Gable studs spaced at 4-0-0 oc.
- This truss has been designed for a 10.0 psf bottom chord live load nonconcurrent with any other live loads.
- * This truss has been designed for a live load of 20.0psf on the bottom chord in all areas where a rectangle 3-06-00 tall by 2-00-00 wide will fit between the bottom chord and any other members, with BCDL = 10.0psf.
- Provide mechanical connection (by others) of truss to bearing plate capable of withstanding 85 lb uplift at joint 1, 10 lb uplift at joint 7, 327 lb uplift at joint 11, 280 lb uplift at joint 13, 328 lb uplift at joint 9 and 274 lb uplift at joint 8.
- This truss design requires that a minimum of 7/16" structural wood sheathing be applied directly to the top chord and 1/2" gypsum sheetrock be applied directly to the bottom chord.

LOAD CASE(S) Standard

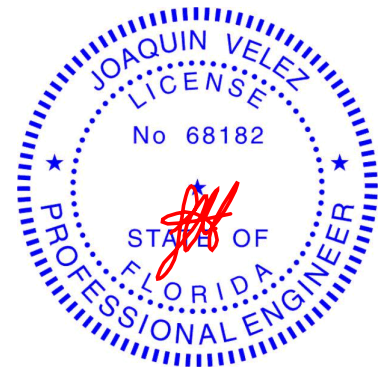

Joaquin Velez PE No.68182
MiTek USA, Inc. FL Cert 6634
6904 Parke East Blvd. Tampa FL 33610
Date:

April 7, 2022

WARNING - Verify design parameters and READ NOTES ON THIS AND INCLUDED MITEK REFERENCE PAGE MII-7473 rev. 5/19/2020 BEFORE USE.

Design valid for use only with MiTek® connectors. This design is based only upon parameters shown, and is for an individual building component, not a truss system. Before use, the building designer must verify the applicability of design parameters and properly incorporate this design into the overall building design. Bracing indicated is to prevent buckling of individual truss web and/or chord members only. Additional temporary and permanent bracing is always required for stability and to prevent collapse with possible personal injury and property damage. For general guidance regarding the fabrication, storage, delivery, erection and bracing of trusses and truss systems, see

ANSI/TPI1 Quality Criteria, DSB-89 and BCSI Building Component

Safety Information available from Truss Plate Institute, 2670 Crain Highway, Suite 203 Waldorf, MD 20601



6904 Parke East Blvd.
Tampa, FL 33610

Job 3039076	Truss V04	Truss Type Valley	Qty 1	Ply 1	Job Reference (optional)	T27365454
----------------	--------------	----------------------	----------	----------	--------------------------	-----------

Builders FirstSource (Groveland, FL), Groveland, FL - 34736,

Run: 8.53 S Dec 6 2021 Print: 8.530 S Dec 6 2021 MiTek Industries, Inc. Wed Apr 06 15:10:14
ID:Je0TgCaSioGHAn7I9RVPzTkHk-RfC?PsB70Hq3NSgPqnLw3ulTXbGkWrCDoi7J4zJC?f

Page: 1

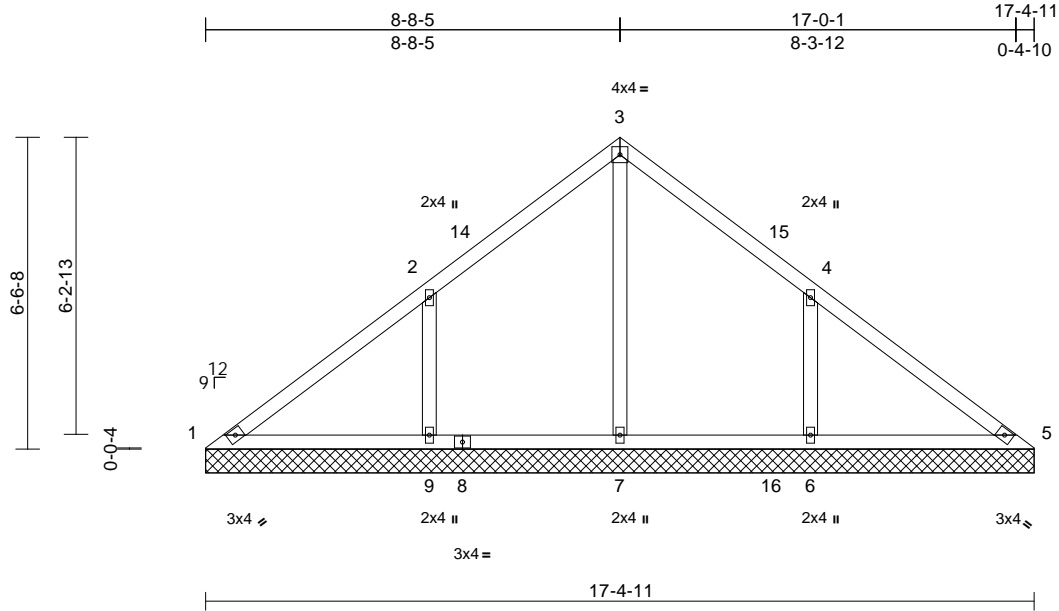

Loading	(psf)	Spacing	2-0-0	CSI	DEFL	in	(loc)	l/defl	L/d	PLATES	GRIP	
TCLL (roof)	20.0	Plate Grip DOL	1.25	TC	0.24	Vert(LL)	n/a	-	n/a	999	MT20	244/190
TCDL	10.0	Lumber DOL	1.25	BC	0.17	Vert(TL)	n/a	-	n/a	999		
BCLL	0.0*	Rep Stress Incr	YES	WB	0.26	Horiz(TL)	0.00	5	n/a	n/a		
BCDL	10.0	Code	FBC2020/TPI2014	Matrix-AS							Weight: 74 lb	FT = 20%

LUMBER
TOP CHORD 2x4 SP No.2
BOT CHORD 2x4 SP No.2
OTHERS 2x4 SP No.3

BRACING
TOP CHORD Structural wood sheathing directly applied.
BOT CHORD Rigid ceiling directly applied.

REACTIONS (lb/size)
1=93/17-4-11, 5=93/17-4-11,
6=408/17-4-11, 7=388/17-4-11,
9=408/17-4-11
Max Horiz 1=246 (LC 9)
Max Uplift 1=-45 (LC 6), 6=-377 (LC 11),
7=-24 (LC 10), 9=381 (LC 10)
Max Grav 1=133 (LC 18), 5=105 (LC 22),
6=575 (LC 18), 7=529 (LC 17),
9=581 (LC 17)

FORCES (lb) - Maximum Compression/Maximum Tension
TOP CHORD 1-2=-229/318, 2-3=-45/216, 3-4=-9/188,
4-5=-166/249
BOT CHORD 1-9=-180/228, 7-9=-180/228, 6-7=-180/228,
5-6=-180/228
WEBS 3-7=-348/77, 2-9=-369/389, 4-6=-367/387

- NOTES**
- 1) Unbalanced roof live loads have been considered for this design.
 - 2) Wind: ASCE 7-16; Vult=140mph (3-second gust) Vasd=108mph; TCCL=4.2psf; BCDL=5.0psf; h=25ft; Cat. II; Exp C; Enclosed; MWFRS (envelope) exterior zone and C-C Exterior(2E) 0-0-5 to 3-0-5, Interior (1) 3-0-5 to 5-8-11, Exterior(2R) 5-8-11 to 11-8-11, Interior (1) 11-8-11 to 14-5-0, Exterior(2E) 14-5-0 to 17-5-0 zone; end vertical left and right exposed; C-C for members and forces & MWFRS for reactions shown; Lumber DOL=1.60 plate grip DOL=1.60
 - 3) Truss designed for wind loads in the plane of the truss only. For studs exposed to wind (normal to the face), see Standard Industry Gable End Details as applicable, or consult qualified building designer as per ANSI/TPI 1.

- 4) Building Designer / Project engineer responsible for verifying applied roof live load shown covers rain loading requirements specific to the use of this truss component.
- 5) Gable requires continuous bottom chord bearing.
- 6) Gable studs spaced at 4-0-0 oc.
- 7) This truss has been designed for a 10.0 psf bottom chord live load nonconcurrent with any other live loads.
- 8) * This truss has been designed for a live load of 20.0psf on the bottom chord in all areas where a rectangle 3-06-00 tall by 2-00-00 wide will fit between the bottom chord and any other members, with BCDL = 10.0psf.
- 9) Provide mechanical connection (by others) of truss to bearing plate capable of withstanding 45 lb uplift at joint 1, 24 lb uplift at joint 7, 381 lb uplift at joint 9 and 377 lb uplift at joint 6.
- 10) This truss design requires that a minimum of 7/16" structural wood sheathing be applied directly to the top chord and 1/2" gypsum sheetrock be applied directly to the bottom chord.

LOAD CASE(S) Standard

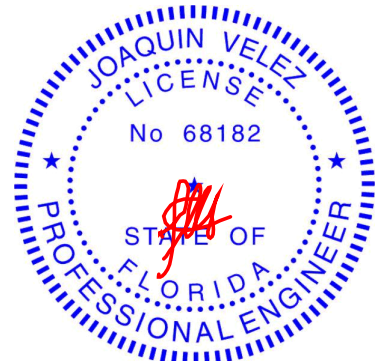

Joaquin Velez PE No.68182
MiTek USA, Inc. FL Cert 6634
6904 Parke East Blvd. Tampa FL 33610
Date:

April 7, 2022

Job 3039076	Truss V05	Truss Type Valley	Qty 1	Ply 1	Job Reference (optional) T27365455
----------------	--------------	----------------------	----------	----------	---------------------------------------

Builders FirstSource (Groveland, FL), Groveland, FL - 34736,

Run: 8.53 S Dec 6 2021 Print: 8.530 S Dec 6 2021 MiTek Industries, Inc. Wed Apr 06 15:10:14
ID:Je0TgCaSioGHAn7lg9RVPzTkHk-RfC?PsB70Hq3NSgPqnLw3ulTXbGkWrCDoi7J4zJC?f

Page: 1

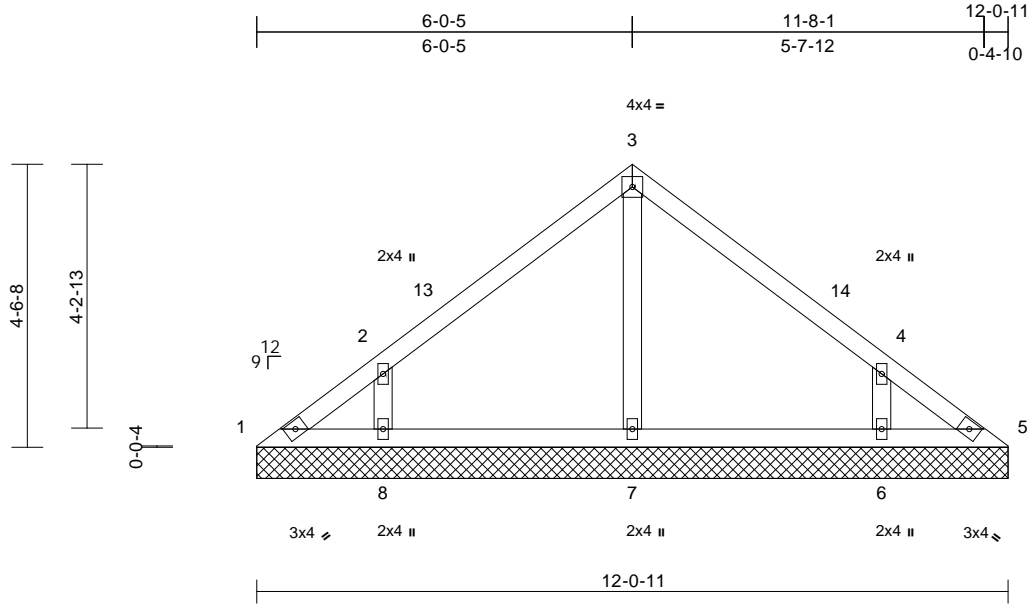

Scale = 1:37

Loading	(psf)	Spacing	2-0-0	CSI	DEFL	in	(loc)	l/defl	L/d	PLATES	GRIP	
TCLL (roof)	20.0	Plate Grip DOL	1.25	TC	0.17	Vert(LL)	n/a	-	n/a	999	MT20	244/190
TCDL	10.0	Lumber DOL	1.25	BC	0.12	Vert(TL)	n/a	-	n/a	999		
BCLL	0.0*	Rep Stress Incr	YES	WB	0.10	Horiz(TL)	0.00	5	n/a	n/a		
BCDL	10.0	Code	FBC2020/TPI2014	Matrix-AS							Weight: 48 lb	FT = 20%

LUMBER

TOP CHORD 2x4 SP No.2
BOT CHORD 2x4 SP No.2
OTHERS 2x4 SP No.3

BRACING

TOP CHORD Structural wood sheathing directly applied.
BOT CHORD Rigid ceiling directly applied.

REACTIONS (lb/size)

1=61/12-0-11, 5=61/12-0-11,
6=291/12-0-11, 7=262/12-0-11,
8=291/12-0-11
Max Horiz 1=-169 (LC 6)
Max Uplift 1=-58 (LC 6), 5=-17 (LC 7), 6=-264 (LC 11), 7=-12 (LC 10), 8=-269 (LC 10)
Max Grav 1=105 (LC 18), 5=74 (LC 17), 6=346 (LC 18), 7=262 (LC 1), 8=351 (LC 17)

FORCES (lb) - Maximum Compression/Maximum Tension

TOP CHORD 1-2=-157/143, 2-3=-150/163, 3-4=-134/163, 4-5=-105/82
BOT CHORD 1-8=-53/92, 7-8=-50/92, 6-7=-50/92, 5-6=-50/92
WEBS 3-7=-177/58, 2-8=-296/345, 4-6=-296/345

NOTES

- Unbalanced roof live loads have been considered for this design.
- Wind: ASCE 7-16; Vult=140mph (3-second gust) Vasd=108mph; TCDL=4.2psf; BCDL=5.0psf; h=25ft; Cat. II; Exp C; Enclosed; MWFRS (envelope) exterior zone and C-C Exterior(2E) 0-0-5 to 3-0-5, Exterior(2R) 3-0-5 to 9-1-0, Exterior(2E) 9-1-0 to 12-1-0 zone; end vertical left and right exposed; C-C for members and forces & MWFRS for reactions shown; Lumber DOL=1.60 plate grip DOL=1.60
- Truss designed for wind loads in the plane of the truss only. For studs exposed to wind (normal to the face), see Standard Industry Gable End Details as applicable, or consult qualified building designer as per ANSI/TPI 1.

- Building Designer / Project engineer responsible for verifying applied roof live load shown covers rain loading requirements specific to the use of this truss component.
- Gable requires continuous bottom chord bearing.
- Gable studs spaced at 4-0-0 oc.
- This truss has been designed for a 10.0 psf bottom chord live load nonconcurrent with any other live loads.
- * This truss has been designed for a live load of 20.0psf on the bottom chord in all areas where a rectangle 3-06-00 tall by 2-00-00 wide will fit between the bottom chord and any other members.
- Provide mechanical connection (by others) of truss to bearing plate capable of withstanding 58 lb uplift at joint 1, 17 lb uplift at joint 5, 12 lb uplift at joint 7, 269 lb uplift at joint 8 and 264 lb uplift at joint 6.
- This truss design requires that a minimum of 7/16" structural wood sheathing be applied directly to the top chord and 1/2" gypsum sheetrock be applied directly to the bottom chord.

LOAD CASE(S) Standard

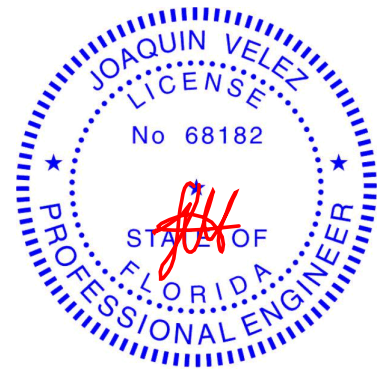

Joaquin Velez PE No.68182
MiTek USA, Inc. FL Cert 6634
6904 Parke East Blvd. Tampa FL 33610
Date:

April 7, 2022

WARNING - Verify design parameters and READ NOTES ON THIS AND INCLUDED MITEK REFERENCE PAGE MII-7473 rev. 5/19/2020 BEFORE USE.

Design valid for use only with MiTek® connectors. This design is based only upon parameters shown, and is for an individual building component, not a truss system. Before use, the building designer must verify the applicability of design parameters and properly incorporate this design into the overall building design. Bracing indicated is to prevent buckling of individual truss web and/or chord members only. Additional temporary and permanent bracing is always required for stability and to prevent collapse with possible personal injury and property damage. For general guidance regarding the fabrication, storage, delivery, erection and bracing of trusses and truss systems, see

ANSI/TPI1 Quality Criteria, DSB-89 and BCSI Building Component

Safety Information available from Truss Plate Institute, 2670 Crain Highway, Suite 203 Waldorf, MD 20601



6904 Parke East Blvd.
Tampa, FL 33610

Job 3039076	Truss V06	Truss Type Valley	Qty 1	Ply 1	Job Reference (optional)	T27365456
----------------	--------------	----------------------	----------	----------	--------------------------	-----------

Builders FirstSource (Groveland, FL), Groveland, FL - 34736,

Run: 8.53 S Dec 6 2021 Print: 8.530 S Dec 6 2021 MiTek Industries, Inc. Wed Apr 06 15:10:15
ID:nrartYb4Txw6vJMKINgg2czTkHj-RfC?PsB70Hq3NSgPqnL8w3uITxBGKwRCDoi7J4zJC?f

Page: 1

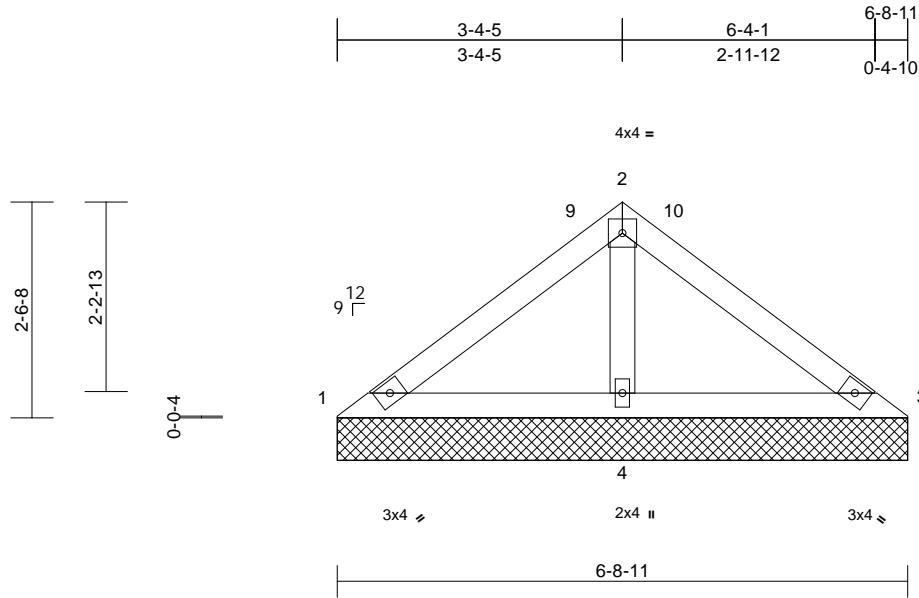

Loading	(psf)	Spacing	2-0-0	CSI	DEFL	in	(loc)	l/defl	L/d	PLATES	GRIP	
TCLL (roof)	20.0	Plate Grip DOL	1.25	TC	0.13	Vert(LL)	n/a	-	n/a	999	MT20	244/190
TCDL	10.0	Lumber DOL	1.25	BC	0.20	Vert(TL)	n/a	-	n/a	999		
BCLL	0.0*	Rep Stress Incr	YES	WB	0.10	Horiz(TL)	0.00	3	n/a	n/a		
BCDL	10.0	Code	FBC2020/TPI2014	Matrix-AS							Weight: 24 lb	FT = 20%

LUMBER
TOP CHORD 2x4 SP No.2
BOT CHORD 2x4 SP No.2
OTHERS 2x4 SP No.3

BRACING
TOP CHORD Structural wood sheathing directly applied.
BOT CHORD Rigid ceiling directly applied.

REACTIONS (lb/size)
1=47/6-8-11, 3=47/6-8-11,
4=443/6-8-11
Max Horiz 1=91 (LC 7)
Max Uplift 1=-6 (LC 10), 3=-22 (LC 11),
4=-205 (LC 10)
Max Grav 1=69 (LC 21), 3=69 (LC 22), 4=443
(LC 1)

FORCES (lb) - Maximum Compression/Maximum Tension
TOP CHORD 1-2=-139/180, 2-3=-139/170
BOT CHORD 1-4=-199/237, 3-4=-199/237
WEBS 2-4=-353/339

- 6) Gable studs spaced at 4-0-0 oc.
7) This truss has been designed for a 10.0 psf bottom chord live load nonconcurrent with any other live loads.
8) * This truss has been designed for a live load of 20.0psf on the bottom chord in all areas where a rectangle 3-06-00 tall by 2-00-00 wide will fit between the bottom chord and any other members.
9) Provide mechanical connection (by others) of truss to bearing plate capable of withstanding 6 lb uplift at joint 1, 22 lb uplift at joint 3 and 205 lb uplift at joint 4.
10) This truss design requires that a minimum of 7/16" structural wood sheathing be applied directly to the top chord and 1/2" gypsum sheetrock be applied directly to the bottom chord.
- LOAD CASE(S)** Standard

- NOTES**
- Unbalanced roof live loads have been considered for this design.
 - Wind: ASCE 7-16; Vult=140mph (3-second gust) Vasd=108mph; TCDL=4.2psf; BCDL=5.0psf; h=25ft; Cat. II; Exp C; Enclosed; MWFRS (envelope) exterior zone and C-C Exterior(2E) 0-0-5 to 3-0-5, Exterior(2R) 3-0-5 to 3-9-0, Exterior(2E) 3-9-0 to 6-9-0 zone; end vertical left and right exposed; C-C for members and forces & MWFRS for reactions shown; Lumber DOL=1.60 plate grip DOL=1.60
 - Truss designed for wind loads in the plane of the truss only. For studs exposed to wind (normal to the face), see Standard Industry Gable End Details as applicable, or consult qualified building designer as per ANSI/TPI 1.
 - Building Designer / Project engineer responsible for verifying applied roof live load shown covers rain loading requirements specific to the use of this truss component.
 - Gable requires continuous bottom chord bearing.

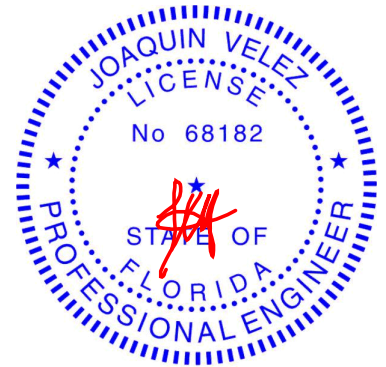

Joaquin Velez PE No.68182
MiTek USA, Inc. FL Cert 6634
6904 Parke East Blvd. Tampa FL 33610
Date:

April 7, 2022

WARNING - Verify design parameters and READ NOTES ON THIS AND INCLUDED MITEK REFERENCE PAGE MII-7473 rev. 5/19/2020 BEFORE USE.

Design valid for use only with MiTek® connectors. This design is based only upon parameters shown, and is for an individual building component, not a truss system. Before use, the building designer must verify the applicability of design parameters and properly incorporate this design into the overall building design. Bracing indicated is to prevent buckling of individual truss web and/or chord members only. Additional temporary and permanent bracing is always required for stability and to prevent collapse with possible personal injury and property damage. For general guidance regarding the fabrication, storage, delivery, erection and bracing of trusses and truss systems, see

ANSI/TPI1 Quality Criteria, DSB-89 and BCSI Building Component

Safety Information available from Truss Plate Institute, 2670 Crain Highway, Suite 203 Waldorf, MD 20601



6904 Parke East Blvd.
Tampa, FL 36610

Job 3039076	Truss V07	Truss Type Valley	Qty 1	Ply 1	Job Reference (optional) T27365457
----------------	--------------	----------------------	----------	----------	---------------------------------------

Builders FirstSource (Groveland, FL), Groveland, FL - 34736,

Run: 8.53 S Dec 6 2021 Print: 8.530 S Dec 6 2021 MiTek Industries, Inc. Wed Apr 06 15:10:15
ID:kGIZbumnpuEwoF6Kqwa_UzTU9u-RfC?PsB70Hq3NSgPqnL8w3uITXbGKWRcDoi7J4zJC?f

Page: 1

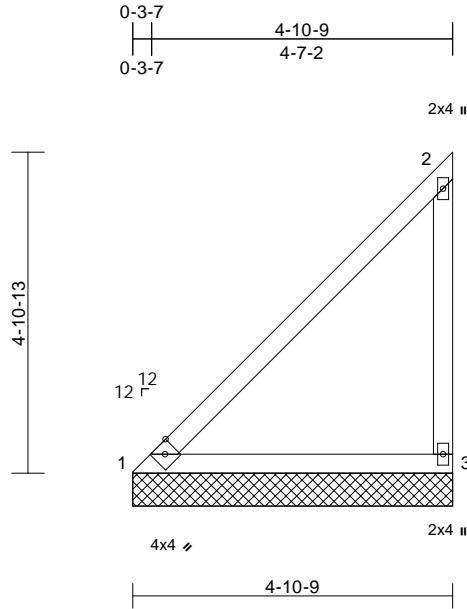

Scale = 1:35.2

Loading	(psf)	Spacing	2-0-0	CSI	DEFL	in	(loc)	l/defl	L/d	PLATES	GRIP	
TCLL (roof)	20.0	Plate Grip DOL	1.25	TC	0.58	Vert(LL)	n/a	-	n/a	999	MT20	244/190
TCDL	10.0	Lumber DOL	1.25	BC	0.58	Vert(TL)	n/a	-	n/a	999		
BCLL	0.0*	Rep Stress Incr	YES	WB	0.00	Horiz(TL)	-0.01	3	n/a	n/a		
BCDL	10.0	Code	FBC2020/TPI2014	Matrix-AS							Weight: 23 lb	FT = 20%

LUMBER

TOP CHORD 2x4 SP No.2
BOT CHORD 2x4 SP No.2
WEBS 2x4 SP No.3

BRACING

TOP CHORD Structural wood sheathing directly applied, except end verticals.
BOT CHORD Rigid ceiling directly applied.

REACTIONS

(lb/size) 1=189/4-10-9, 3=189/4-10-9
Max Horiz 1=265 (LC 7)
Max Uplift 1=-32 (LC 10), 3=-167 (LC 10)
Max Grav 1=232 (LC 18), 3=264 (LC 17)

FORCES

(lb) - Maximum Compression/Maximum Tension
TOP CHORD 1-2=-277/137, 2-3=-189/215
BOT CHORD 1-3=-183/211

NOTES

- 1) Wind: ASCE 7-16; Vult=140mph (3-second gust)
Vasd=108mph; TCDL=4.2psf; BCDL=5.0psf; h=25ft;
Cat. II; Exp C; Enclosed; MWFRS (envelope) exterior zone and C-C Exterior(2E) zone; end vertical left and right exposed; C-C for members and forces & MWFRS for reactions shown; Lumber DOL=1.60 plate grip DOL=1.60
- 2) Truss designed for wind loads in the plane of the truss only. For studs exposed to wind (normal to the face), see Standard Industry Gable End Details as applicable, or consult qualified building designer as per ANSI/TPI 1.
- 3) Building Designer / Project engineer responsible for verifying applied roof live load shown covers rain loading requirements specific to the use of this truss component.
- 4) Gable requires continuous bottom chord bearing.
- 5) Gable studs spaced at 4-0-0 oc.
- 6) This truss has been designed for a 10.0 psf bottom chord live load nonconcurrent with any other live loads.

- 7) * This truss has been designed for a live load of 20.0psf on the bottom chord in all areas where a rectangle 3-06-00 tall by 2-00-00 wide will fit between the bottom chord and any other members.
 - 8) Provide mechanical connection (by others) of truss to bearing plate capable of withstanding 167 lb uplift at joint 3 and 32 lb uplift at joint 1.
 - 9) This truss design requires that a minimum of 7/16" structural wood sheathing be applied directly to the top chord and 1/2" gypsum sheetrock be applied directly to the bottom chord.
- LOAD CASE(S)** Standard

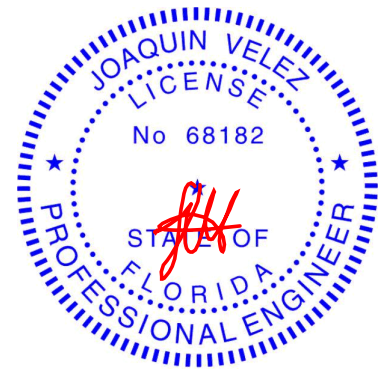

Joaquin Velez PE No.68182
MiTek USA, Inc. FL Cert 6634
6904 Parke East Blvd. Tampa FL 33610
Date:

April 7, 2022

WARNING - Verify design parameters and READ NOTES ON THIS AND INCLUDED MITEK REFERENCE PAGE MII-7473 rev. 5/19/2020 BEFORE USE.

Design valid for use only with MiTek® connectors. This design is based only upon parameters shown, and is for an individual building component, not a truss system. Before use, the building designer must verify the applicability of design parameters and properly incorporate this design into the overall building design. Bracing indicated is to prevent buckling of individual truss web and/or chord members only. Additional temporary and permanent bracing is always required for stability and to prevent collapse with possible personal injury and property damage. For general guidance regarding the fabrication, storage, delivery, erection and bracing of trusses and truss systems, see

ANSI/TPI1 Quality Criteria, DSB-89 and BCSI Building Component

Safety Information available from Truss Plate Institute, 2670 Crain Highway, Suite 203 Waldorf, MD 20601



6904 Parke East Blvd.
Tampa, FL 33610

Job 3039076	Truss V08	Truss Type Valley	Qty 1	Ply 1	Job Reference (optional) T27365458
----------------	--------------	----------------------	----------	----------	---------------------------------------

Builders FirstSource (Groveland, FL), Groveland, FL - 34736,

Run: 8.53 S Dec 6 2021 Print: 8.530 S Dec 6 2021 MiTek Industries, Inc. Wed Apr 06 15:10:15
ID:d2X4RFqHj2OgPPYzG_W8KzTU9q-RfC?PsB70Hq3NSgPqL8w3uITXbGKWrCDoi7J4zJC?f

Page: 1

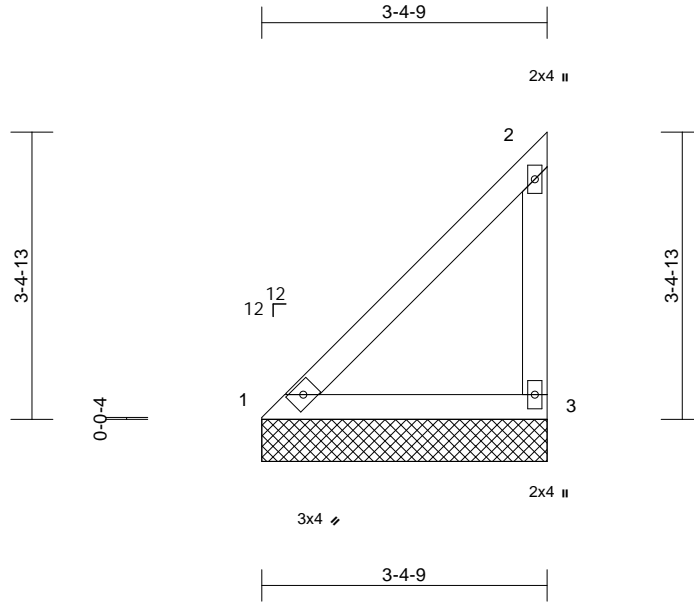

Scale = 1:27.3

Loading	(psf)	Spacing	2-0-0	CSI	DEFL	in	(loc)	l/defl	L/d	PLATES	GRIP	
TCLL (roof)	20.0	Plate Grip DOL	1.25	TC	0.27	Vert(LL)	n/a	-	n/a	999	MT20	244/190
TCDL	10.0	Lumber DOL	1.25	BC	0.31	Vert(TL)	n/a	-	n/a	999		
BCLL	0.0*	Rep Stress Incr	YES	WB	0.00	Horiz(TL)	0.00	3	n/a	n/a		
BCDL	10.0	Code	FBC2020/TPI2014	Matrix-MP							Weight: 16 lb	FT = 20%

LUMBER

TOP CHORD 2x4 SP No.2
BOT CHORD 2x4 SP No.2
WEBS 2x4 SP No.3

BRACING

TOP CHORD Structural wood sheathing directly applied or 3-4-9 oc purlins, except end verticals.
BOT CHORD Rigid ceiling directly applied or 10-0-0 oc bracing.

REACTIONS

(lb/size) 1=129/3-4-9, 3=129/3-4-9
Max Horiz 1=176 (LC 7)
Max Uplift 1=-23 (LC 10), 3=-113 (LC 10)
Max Grav 1=156 (LC 18), 3=179 (LC 17)

FORCES

(lb) - Maximum Compression/Maximum Tension

TOP CHORD 1-2=-182/89, 2-3=-123/161
BOT CHORD 1-3=-149/139

NOTES

- 1) Wind: ASCE 7-16; Vult=140mph (3-second gust)
Vasd=108mph; TCDL=4.2psf; BCDL=5.0psf; h=25ft;
Cat. II; Exp C; Enclosed; MWFRS (envelope) exterior zone and C-C Exterior(2E) zone; end vertical left and right exposed;C-C for members and forces & MWFRS for reactions shown; Lumber DOL=1.60 plate grip DOL=1.60
- 2) Truss designed for wind loads in the plane of the truss only. For studs exposed to wind (normal to the face), see Standard Industry Gable End Details as applicable, or consult qualified building designer as per ANSI/TPI 1.
- 3) Building Designer / Project engineer responsible for verifying applied roof live load shown covers rain loading requirements specific to the use of this truss component.
- 4) Gable requires continuous bottom chord bearing.
- 5) Gable studs spaced at 4-0-0 oc.
- 6) This truss has been designed for a 10.0 psf bottom chord live load nonconcurrent with any other live loads.

- 7) * This truss has been designed for a live load of 20.0psf on the bottom chord in all areas where a rectangle 3-06-00 tall by 2-00-00 wide will fit between the bottom chord and any other members.
- 8) Provide mechanical connection (by others) of truss to bearing plate capable of withstanding 113 lb uplift at joint 3 and 23 lb uplift at joint 1.

LOAD CASE(S) Standard

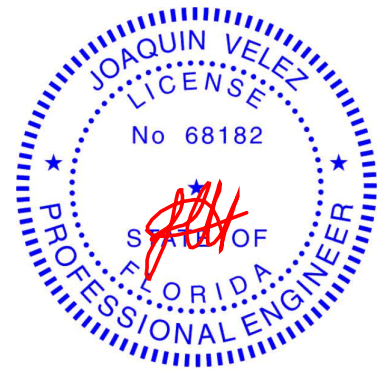

Joaquin Velez PE No.68182
MiTek USA, Inc. FL Cert 6634
6904 Parke East Blvd. Tampa FL 33610
Date:

April 7, 2022

WARNING - Verify design parameters and READ NOTES ON THIS AND INCLUDED MITEK REFERENCE PAGE MII-7473 rev. 5/19/2020 BEFORE USE.

Design valid for use only with MiTek® connectors. This design is based only upon parameters shown, and is for an individual building component, not a truss system. Before use, the building designer must verify the applicability of design parameters and properly incorporate this design into the overall building design. Bracing indicated is to prevent buckling of individual truss web and/or chord members only. Additional temporary and permanent bracing is always required for stability and to prevent collapse with possible personal injury and property damage. For general guidance regarding the fabrication, storage, delivery, erection and bracing of trusses and truss systems, see

ANSI/TPI1 Quality Criteria, DSB-89 and BCSI Building Component

Safety Information available from Truss Plate Institute, 2670 Crain Highway, Suite 203 Waldorf, MD 20601



6904 Parke East Blvd.
Tampa, FL 36610

Symbols

PLATE LOCATION AND ORIENTATION

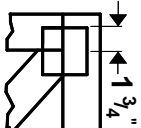

Center plate on joint unless x, y offsets are indicated. Dimensions are in ft-in-sixteenths. Apply plates to both sides of truss and fully embed teeth.

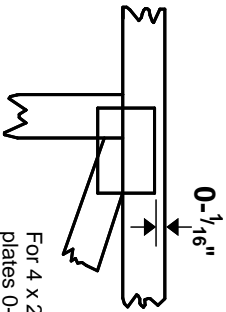

For 4 x 2 orientation, locate plates 0- 1/16" from outside edge of truss.



This symbol indicates the required direction of slots in connector plates.

* Plate location details available in **MITek 20/20 software** or upon request.

PLATE SIZE

4 X 4

The first dimension is the plate width measured perpendicular to slots. Second dimension is the length parallel to slots.

LATERAL BRACING LOCATION



Indicated by symbol shown and/or by text in the bracing section of the output. Use T or I bracing if indicated.

BEARING

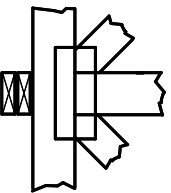

Indicates location where bearings (supports) occur. Icons vary but reaction section indicates joint number where bearings occur. Min size shown is for crushing only.

Industry Standards:

ANSI/TPI 1: National Design Specification for Metal Plate Connected Wood Truss Construction.
DSB-89: Design Standard for Bracing, Building Component Safety Information, Guide to Good Practice for Handling, Installing & Bracing of Metal Plate Connected Wood Trusses.

Numbering System

6-4-8 dimensions shown in ft-in-sixteenths (Drawings not to scale)

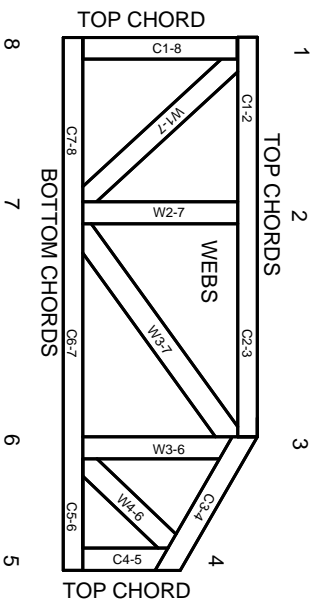

JOINTS ARE GENERALLY NUMBERED/LETTERED CLOCKWISE AROUND THE TRUSS STARTING AT THE JOINT FARTHEST TO THE LEFT.

CHORDS AND WEBS ARE IDENTIFIED BY END JOINT NUMBERS/LETTERS.

PRODUCT CODE APPROVALS

ICC-ES Reports:

ESR-1311, ESR-1352, ESR1988
ER-3907, ESR-2362, ESR-1397, ESR-3282

Trusses are designed for wind loads in the plane of the truss unless otherwise shown.

Lumber design values are in accordance with ANSI/TPI 1 section 6.3 These truss designs rely on lumber values established by others.

© 2012 MITek® All Rights Reserved

General Safety Notes

Failure to Follow Could Cause Property Damage or Personal Injury

1. Additional stability/bracing for truss system, e.g. diagonal or X-bracing, is always required. See BCSI.
2. Truss bracing must be designed by an engineer. For wide truss spacing, individual lateral braces themselves may require bracing, or alternative T or I bracing should be considered.
3. Never exceed the design loading shown and never stack materials on inadequately braced trusses.
4. Provide copies of this truss design to the building designer, erection supervisor, property owner and all other interested parties.
5. Cut members to bear tightly against each other.
6. Place plates on each face of truss at each joint and embed fully. Knots and wane at joint locations are regulated by ANSI/TPI 1.
7. Design assumes trusses will be suitably protected from the environment in accord with ANSI/TPI 1.
8. Unless otherwise noted, moisture content of lumber shall not exceed 19% at time of fabrication.
9. Unless expressly noted, this design is not applicable for use with fire retardant, preservative treated, or green lumber.
10. Camber is a non-structural consideration and is the responsibility of truss fabricator. General practice is to camber for dead load deflection.
11. Plate type, size, orientation and location dimensions indicated are minimum plating requirements.
12. Lumber used shall be of the species and size, and in all respects, equal to or better than that specified.
13. Top chords must be sheathed or purlins provided at spacing indicated on design.
14. Bottom chords require lateral bracing at 10 ft. spacing, or less, if no ceiling is installed, unless otherwise noted.
15. Connections not shown are the responsibility of others.
16. Do not cut or alter truss member or plate without prior approval of an engineer.
17. Install and load vertically unless indicated otherwise.
18. Use of green or treated lumber may pose unacceptable environmental, health or performance risks. Consult with project engineer before use.
19. Review all portions of this design (front, back, words and pictures) before use. Reviewing pictures alone is not sufficient.
20. Design assumes manufacture in accordance with ANSI/TPI 1 Quality Criteria.
21. The design does not take into account any dynamic or other loads other than those expressly stated.



MITek Engineering Reference Sheet: Mill-7473 rev. 5/19/2020

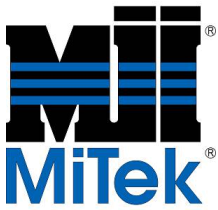

Lumber design values are in accordance with ANSI/TPI 1 section 6.3
These truss designs rely on lumber values established by others.

RE: Details -

MiTek USA, Inc.
6904 Parke East Blvd.
Tampa, FL 33610-4115

Site Information:

Customer Info: Project Name:
Lot/Block: Subdivision:
Address: State:
City:

Name Address and License # of Structural Engineer of Record, If there is one, for the building.

Name: License #:
Address: State:
City:

General Truss Engineering Criteria & Design Loads (Individual Truss Design Drawings Show Special Loading Conditions):

Design Code: FBC2020/TPI2014 Design Program: MiTek 20/20 8.4
Wind Code: ASCE 7-16 Wind Speed: Varies
Roof Load: Varies Floor Load: Varies

This package includes 19 individual, MiTek General Details and 0 Additional Drawings.
With my seal affixed to this sheet, I hereby certify that I am the Truss Design Engineer and this index sheet conforms to 61G15-31.003, section 5 of the Florida Board of Professional Engineers Rules.

No.	Seal#	Truss Name	Date
1	T23949105	MII-T-BRACE 2	5/17/21
2	T23949106	MII-WEBBRACE-2	5/17/21
3	T23949107	MII-SCAB-BRACE	5/17/21
4	T23949108	MII=REP05	5/17/21
5	T23949109	MII-GE-130-D-SP	5/17/21
6	T23949110	MII-GE-130-SP	5/17/21
7	T23949111	LETTER	5/17/21
8	T23949112	MII-GE170-D-SP	5/17/21
9	T23949113	MII-GE-180-D-SP	5/17/21
10	T23949114	MII-PIGGY-7-16	5/17/21
11	T23949115	MII-PIGGY-ALT-7-16	5/17/21
12	T23949116	MII-REP01A1	5/17/21
13	T23949117	MII-TOENAIL SP	5/17/21
14	T23949118	MII-VALLEY HIGH WIND1	5/17/21
15	T23949119	MII-VALLEY HIGH WIND2	5/17/21
16	T23949120	MII-VALLEY-SP	5/17/21
17	T23949121	MII-VALLEY	5/17/21
18	T23949122	MII-REP13B	5/17/21
19	T23949123	MII-STRGBCK	5/17/21

The truss drawing(s) referenced above have been prepared by MiTek USA, Inc. under my direct supervision based on the parameters provided by Builders FirstSource-Jacksonville.

Truss Design Engineer's Name: Magid, Michael
My license renewal date for the state of Florida is February 28, 2023.

IMPORTANT NOTE: The seal on these truss component designs is a certification that the engineer named is licensed in the jurisdiction(s) identified and that the designs comply with ANSI/TPI 1. These designs are based upon parameters shown (e.g., loads, supports, dimensions, shapes and design codes), which were given to MiTek or TRENCO. Any project specific information included is for MiTek's or TRENCO's customers file reference purpose only, and was not taken into account in the preparation of these designs. MiTek or TRENCO has not independently verified the applicability of the design parameters or the designs for any particular building. Before use, the building designer should verify applicability of design parameters and properly incorporate these designs into the overall building design per ANSI/TPI 1, Chapter 2.

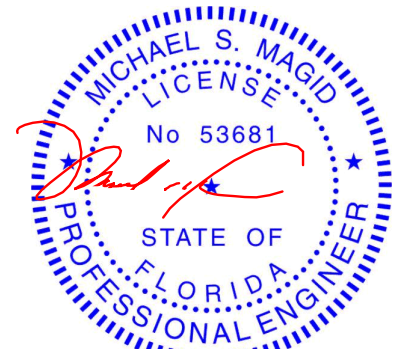

Michael S. Magid PE No.53681
MiTek USA, Inc. FL Cert 6634
6904 Parke East Blvd. Tampa FL 33610
Date:

May 17,2021

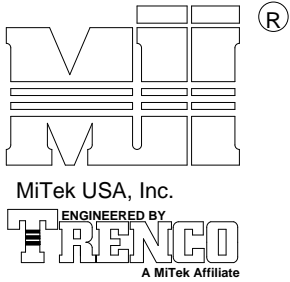

Note: T-Bracing / I-Bracing to be used when continuous lateral bracing is impractical. T-Brace / I-Brace must cover 90% of web length.

Note: This detail NOT to be used to convert T-Brace / I-Brace webs to continuous lateral braced webs.

Nailing Pattern		
T-Brace size	Nail Size	Nail Spacing
2x4 or 2x6 or 2x8	10d (0.131" X 3")	6" o.c.

Note: Nail along entire length of T-Brace / I-Brace (On Two-Ply's Nail to Both Plies)

Brace Size for One-Ply Truss		
Specified Continuous Rows of Lateral Bracing		
Web Size	1	2
2x3 or 2x4	2x4 T-Brace	2x4 I-Brace
2x6	2x6 T-Brace	2x6 I-Brace
2x8	2x8 T-Brace	2x8 I-Brace

Brace Size for Two-Ply Truss		
Specified Continuous Rows of Lateral Bracing		
Web Size	1	2
2x3 or 2x4	2x4 T-Brace	2x4 I-Brace
2x6	2x6 T-Brace	2x6 I-Brace
2x8	2x8 T-Brace	2x8 I-Brace

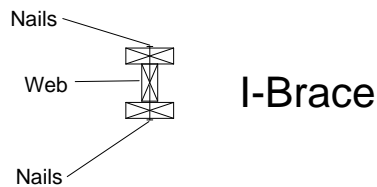
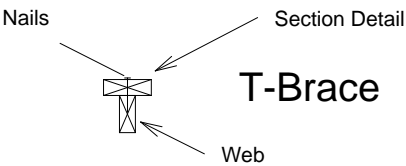
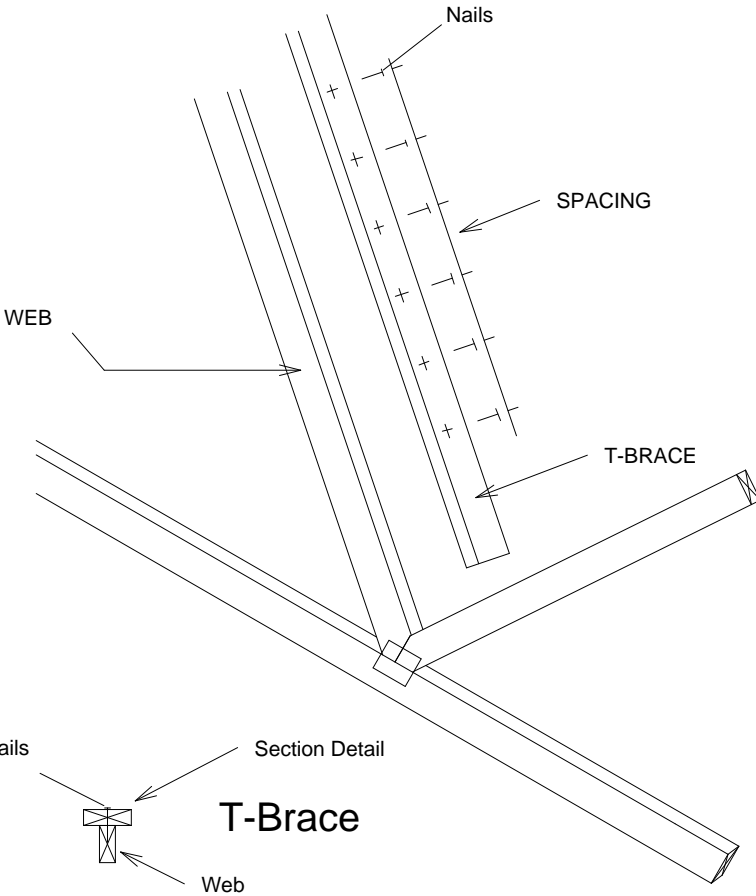

T-Brace / I-Brace must be same species and grade (or better) as web member.

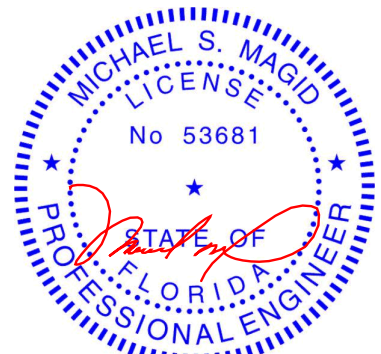

Michael S. Magid PE No.53681
MiTek USA, Inc. FL Cert 6634
6904 Parke East Blvd. Tampa FL 33610
Date:

May 17,2021

WARNING - Verify design parameters and READ NOTES ON THIS AND INCLUDED MITEK REFERENCE PAGE MII-7473 rev. 5/19/2020 BEFORE USE.

Design valid for use only with MiTek® connectors. This design is based only upon parameters shown, and is for an individual building component, not a truss system. Before use, the building designer must verify the applicability of design parameters and properly incorporate this design into the overall building design. Bracing indicated is to prevent buckling of individual truss web and/or chord members only. Additional temporary and permanent bracing is always required for stability and to prevent collapse with possible personal injury and property damage. For general guidance regarding the fabrication, storage, delivery, erection and bracing of trusses and truss systems, see **ANSI/TPI1 Quality Criteria, DSB-89 and BCSI Building Component**

Safety Information available from Truss Plate Institute, 2670 Crain Highway, Suite 203 Waldorf, MD 20601



6904 Parke East Blvd.
Tampa, FL 33610

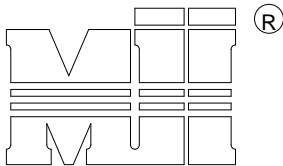

MiTek USA, Inc.

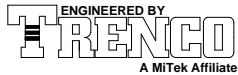

MAXIMUM TRUSS WEB FORCE (lbs.) ⁷								
BRACE BAY SIZE ⁸	24" O.C. TRUSS SPACING			48" O.C. TRUSS SPACING			72" O.C. TRUSS SPACING	
	BRACING MATERIAL TYPE			BRACING MATERIAL TYPE			BRACING MATERIAL TYPE	
	A	B	C	A	B	C	B	C
10'-0"	1886	1886	2829	-----	-----	-----	-----	-----
12'-0"	1572	1572	2358	3143	3143	4715	4715	7074
14'-0"	1347	1347	2021	-----	-----	-----	-----	-----
16'-0"	1179	1179	1768	2358	2358	3536	-----	-----
18'-0"	1048	1048	1572	-----	-----	-----	3143	4715
20'-0"	943	943	1414	1886	1886	2829	-----	-----

GENERAL NOTES

- DIAGONAL BRACING AND BLOCKING IS REQUIRED TO TRANSFER THE CUMULATIVE LATERAL BRACE FORCE INTO THE ROOF AND/OR CEILING DIAPHRAGM. THE DIAPHRAGM IS AND ANY BLOCKING TO BE DESIGNED BY A QUALIFIED PROFESSIONAL.
- TABULATED VALUES ARE BASED ON LATERAL BRACE CARRYING 2% OF THE WEB FORCE WITH A DOL = 1.15.
- DIAGONAL BRACING MATERIAL MUST BE SAME SIZE AND GRADE OR BETTER, AS THE LATERAL BRACE MATERIAL, AND SHALL BE INSTALLED IN SUCH A MANNER THAT IT INTERSECTS WEB MEMBERS AT APPROX. 45 DEGREES AND SHALL BE NAILED AT EACH END AND EACH INTERMEDIATE TRUSS WITH 2 - (0.131"x 3") FOR 2x3 and 2x4 BRACES, AND 3- (0.131"x3") FOR 2x6 BRACES.
- CONNECT LATERAL BRACE TO EACH TRUSS WITH 2 - (0.131"x3") NAILS FOR 2x3 AND 2x4 LATERAL BRACES AND 3- (0.131"x3") FOR 2x6 LATERAL BRACES.
- LATERAL BRACE SHOULD BE CONTINUOUS AND SHOULD OVERLAP AT LEAST ONE TRUSS SPACE FOR CONTINUITY.
- FOR ADDITIONAL GUIDANCE REGARDING DESIGN AND INSTALLATION OF BRACING, CONSULT DSB-89 TEMPORARY BRACING OF METAL PLATE CONNECTED WOOD TRUSSES AND BCSI 1 GUIDE TO GOOD PRACTICE FOR HANDLING, INSTALLING, RESTRAINING & BRACING OF METAL PLATE CONNECTED WOOD TRUSSES, PRODUCED BY STRUCTURAL BUILDING COMPONENT ASSOCIATION. www.sbcindustry.com
- REFER TO SPECIFIC MITek/TRENCO TRUSS DESIGN DRAWING FOR WEB MEMBER FORCE.
- BAY SIZE SHALL BE MEASURED IN BETWEEN THE CENTERS OF PAIRS OF DIAGONALS.

TYPE	BRACING MATERIALS
A	2 X 3 #3, STD, CONST (SPF, DF, HF, OR SP)
B	2 X 4 #3, STD, CONST (SPF, DF, HF, OR SP)
C	2 X 6 #3 OR BETTER (SPF, DF, HF, OR SP)

FOR STABILIZERS:

FOR A SPACING OF 24" O.C. ONLY, MITEK "STABILIZER" TRUSS BRACING SYSTEMS CAN BE SUBSTITUTED FOR TYPE A, B AND C BRACING MATERIAL. DIAGONAL BRACING FOR STABILIZERS ARE TO BE PROVIDED AT BAY SIZE INDICATED ABOVE. WHERE DIAPHRAGM BRACING IS REQUIRED AT PITCH BREAKS, STABILIZERS MAY BE REPLACED WITH WOOD BLOCKING. SEE "STABILIZER" TRUSS BRACING INSTALLATION GUIDE AND PRODUCT SPECIFICATION.

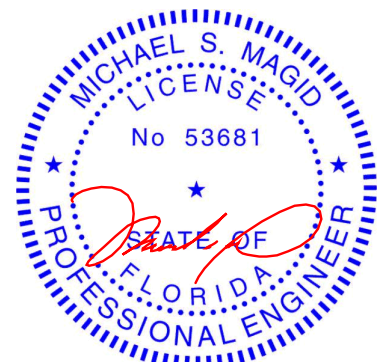
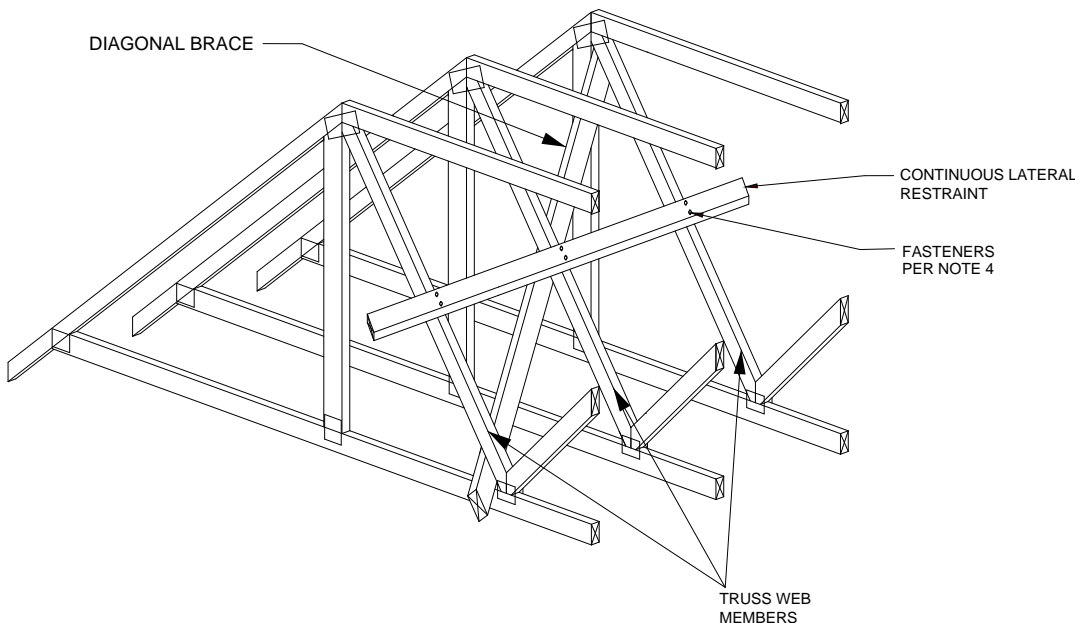

Michael S. Magid PE No.53681
 MiTek USA, Inc. FL Cert 6634
 6904 Parke East Blvd. Tampa FL 33610
 Date:

May 17, 2021

This information is provided to assist in the requirement for permanent bracing of the individual truss web members. Additional bracing may still be required for the stability of the overall roof system. The method shown here is just one method that can be used to provide stability against web buckling. Engineering seal, if any, is supporting the web force chart only.

WARNING - Verify design parameters and READ NOTES ON THIS AND INCLUDED MITEK REFERENCE PAGE MII-7473 rev. 5/19/2020 BEFORE USE.
 Design valid for use only with MiTek® connectors. This design is based only upon parameters shown, and is for an individual building component, not a truss system. Before use, the building designer must verify the applicability of design parameters and properly incorporate this design into the overall building design. Bracing indicated is to prevent buckling of individual truss web and/or chord members only. Additional temporary and permanent bracing is always required for stability and to prevent collapse with possible personal injury and property damage. For general guidance regarding the fabrication, storage, delivery, erection and bracing of trusses and truss systems, see **ANSI/TPI1 Quality Criteria, DSB-89 and BCSI Building Component Safety Information** available from Truss Plate Institute, 2670 Crain Highway, Suite 203 Waldorf, MD 20601



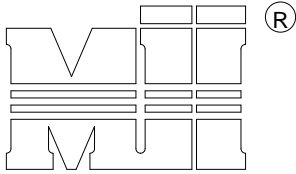

Note: Scab-Bracing to be used when continuous lateral bracing at midpoint (or T-Brace) is impractical. Scab must cover full length of web +/- 6".

*** THIS DETAIL IS NOT APPLICABLE WHEN BRACING IS REQUIRED AT 1/3 POINTS OR I-BRACE IS SPECIFIED.

APPLY 2x___ SCAB TO ONE FACE OF WEB WITH 2 ROWS OF 10d (0.131" X 3") NAILS SPACED 6" O.C. SCAB MUST BE THE SAME GRADE, SIZE AND SPECIES (OR BETTER) AS THE WEB.

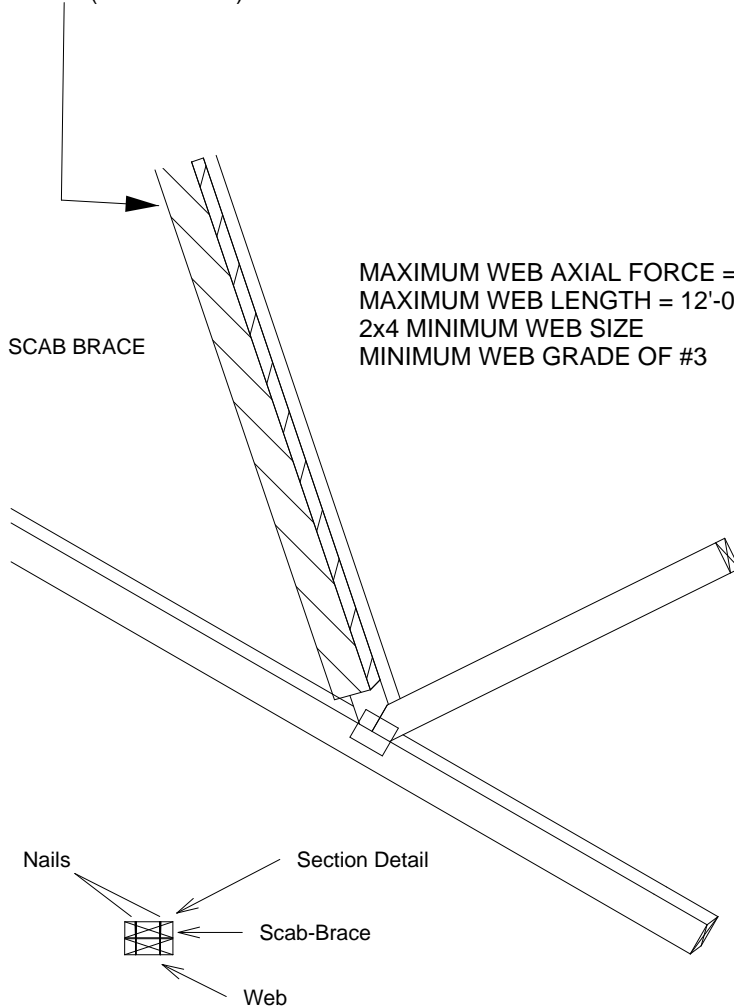

MAXIMUM WEB AXIAL FORCE = 2500 lbs
MAXIMUM WEB LENGTH = 12'-0"
2x4 MINIMUM WEB SIZE
MINIMUM WEB GRADE OF #3

Scab-Brace must be same species grade (or better) as web member.

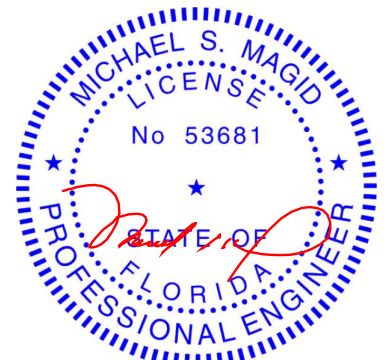

Michael S. Magid PE No.53681
MiTek USA, Inc. FL Cert 6634
6904 Parke East Blvd. Tampa FL 33610
Date:

May 17,2021

WARNING - Verify design parameters and READ NOTES ON THIS AND INCLUDED MITEK REFERENCE PAGE MII-7473 rev. 5/19/2020 BEFORE USE.

Design valid for use only with MiTek® connectors. This design is based only upon parameters shown, and is for an individual building component, not a truss system. Before use, the building designer must verify the applicability of design parameters and properly incorporate this design into the overall building design. Bracing indicated is to prevent buckling of individual truss web and/or chord members only. Additional temporary and permanent bracing is always required for stability and to prevent collapse with possible personal injury and property damage. For general guidance regarding the fabrication, storage, delivery, erection and bracing of trusses and truss systems, see ANSITP11 Quality Criteria, DSB-89 and BCSI Building Component Safety Information available from Truss Plate Institute, 2670 Crain Highway, Suite 203 Waldorf, MD 20601



6904 Parke East Blvd.
Tampa, FL 36610

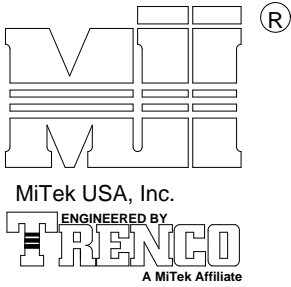

1. THIS IS A SPECIFIC REPAIR DETAIL TO BE USED ONLY FOR ITS ORIGINAL INTENTION. THIS REPAIR DOES NOT IMPLY THAT THE REMAINING PORTION OF THE TRUSS IS UNDAMAGED. THE ENTIRE TRUSS SHALL BE INSPECTED TO VERIFY THAT NO FURTHER REPAIRS ARE REQUIRED. WHEN THE REQUIRED REPAIRS ARE PROPERLY APPLIED, THE TRUSS WILL BE CAPABLE OF SUPPORTING THE LOADS INDICATED.
2. ALL MEMBERS MUST BE RETURNED TO THEIR ORIGINAL POSITIONS BEFORE APPLYING REPAIR AND HELD IN PLACE DURING APPLICATION OF REPAIR.
3. THE END DISTANCE, EDGE DISTANCE, AND SPACING OF NAILS SHALL BE SUCH AS TO AVOID SPLITTING OF THE WOOD.
4. LUMBER MUST BE CUT CLEANLY AND ACCURATELY AND THE REMAINING WOOD MUST BE UNDAMAGED.
5. THIS REPAIR IS TO BE USED FOR SINGLE PLY TRUSSES IN THE 4X_ORIENTATION ONLY.
6. CONNECTOR PLATES MUST BE FULLY IMBEDDED AND UNDISTURBED.

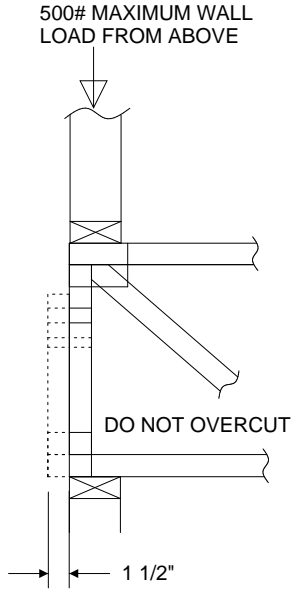

REFER TO INDIVIDUAL TRUSS DESIGN FOR PLATE SIZES AND LUMBER GRADES

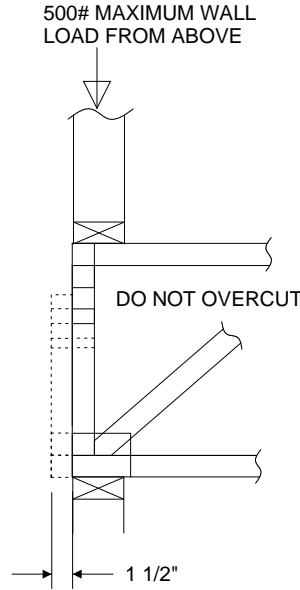

TRUSSES BUILT WITH 4x2 MEMBERS

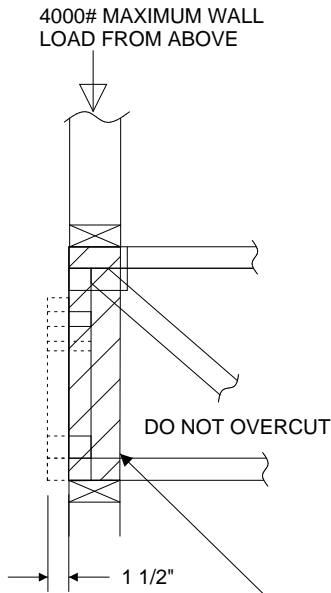

REFER TO INDIVIDUAL TRUSS DESIGN FOR PLATE SIZES AND LUMBER GRADES

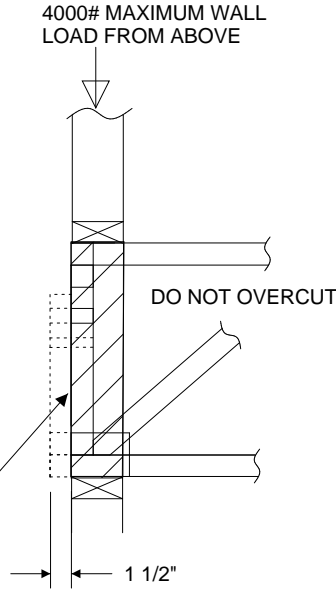

TRUSSES BUILT WITH 4x2 MEMBERS

ATTACH 2x4 SQUASH BLOCK (CUT TO FIT TIGHTLY) TO BOTH SIDES OF THE TRUSS AS SHOWN WITH 10d (0.131" X 3") NAILS SPACED 3" O.C.

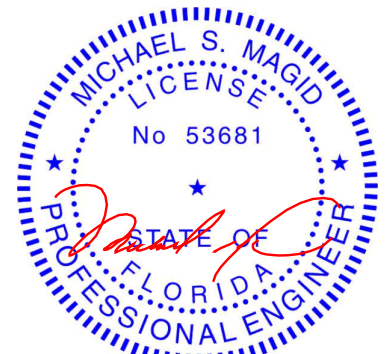

Michael S. Magid PE No.53681
MiTek USA, Inc. FL Cert 6634
6904 Parke East Blvd. Tampa FL 33610
Date:

May 17,2021

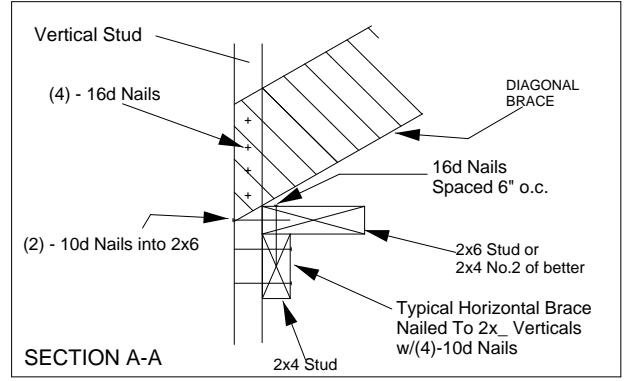
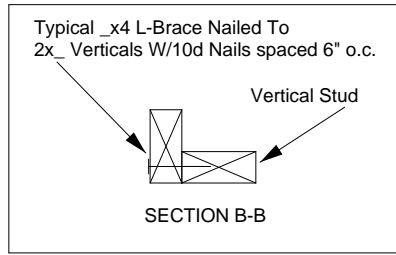
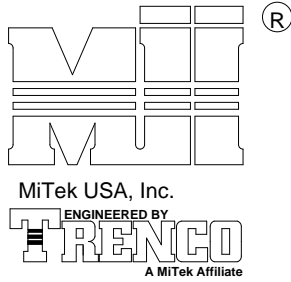

TRUSS GEOMETRY AND CONDITIONS SHOWN ARE FOR ILLUSTRATION ONLY.

PROVIDE 2x4 BLOCKING BETWEEN THE FIRST TWO TRUSSES AS NOTED. TOENAIL BLOCKING TO TRUSSES WITH (2) - 10d NAILS AT EACH END. ATTACH DIAGONAL BRACE TO BLOCKING WITH (5) - 10d NAILS.

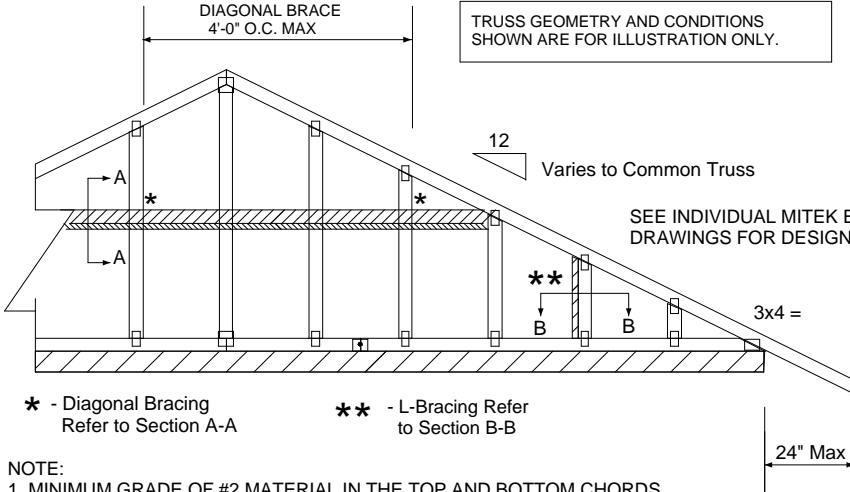

- NOTE:
- MINIMUM GRADE OF #2 MATERIAL IN THE TOP AND BOTTOM CHORDS.
 - CONNECTION BETWEEN BOTTOM CHORD OF GABLE END TRUSS AND WALL TO BE PROVIDED BY PROJECT ENGINEER OR ARCHITECT.
 - BRACING SHOWN IS FOR INDIVIDUAL TRUSS ONLY. CONSULT BLDG. ARCHITECT OR ENGINEER FOR TEMPORARY AND PERMANENT BRACING OF ROOF SYSTEM.
 - "L" BRACES SPECIFIED ARE TO BE FULL LENGTH. GRADES: 1x4 SRB OR 2x4 STUD OR BETTER WITH ONE ROW OF 10d NAILS SPACED 6" O.C.
 - DIAGONAL BRACE TO BE APPROXIMATELY 45 DEGREES TO ROOF DIAPHRAM AT 4'-0" O.C.
 - CONSTRUCT HORIZONTAL BRACE CONNECTING A 2x6 STUD AND A 2x4 STUD AS SHOWN WITH 16d NAILS SPACED 6" O.C. HORIZONTAL BRACE TO BE LOCATED AT THE MIDSPAN OF THE LONGEST STUD. ATTACH TO VERTICAL STUDS WITH (4) 10d NAILS THROUGH 2x4. (REFER TO SECTION A-A)
 - GABLE STUD DEFLECTION MEETS OR EXCEEDS L/240.
 - THIS DETAIL DOES NOT APPLY TO STRUCTURAL GABLES.
 - DO NOT USE FLAT BOTTOM CHORD GABLES NEXT TO SCISSOR TYPE TRUSSES.
 - SOUTHERN PINE LUMBER DESIGN VALUES ARE THOSE EFFECTIVE 06-01-13 BY SPIB/ALSC.
 - NAILS DESIGNATED 10d ARE (0.131" X 3") AND NAILS DESIGNATED 16d ARE (0.131" X 3.5")

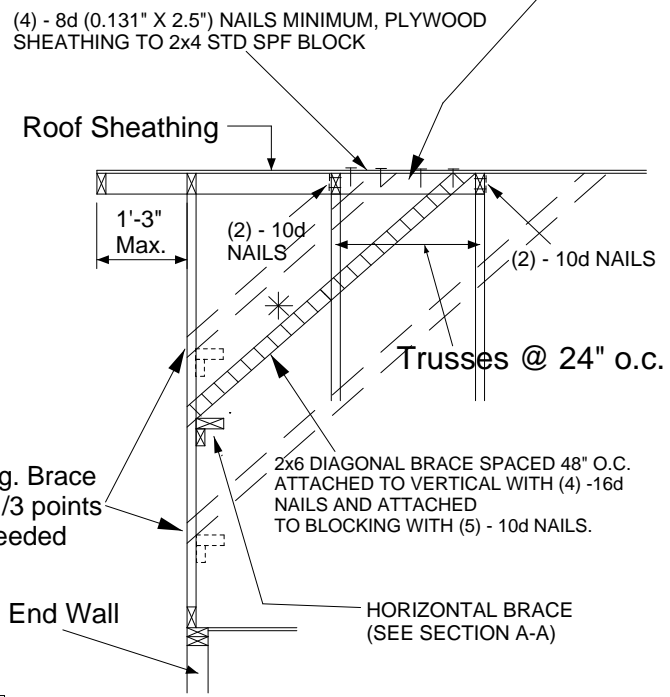

Minimum Stud Size Species and Grade	Stud Spacing	Without Brace	1x4 L-Brace	2x4 L-Brace	DIAGONAL BRACE	2 DIAGONAL BRACES AT 1/3 POINTS
		Maximum Stud Length				
2x4 SP No. 3 / Stud	12" O.C.	3-9-13	4-1-1	5-9-6	7-1-3	11-5-7
2x4 SP No. 3 / Stud	16" O.C.	3-5-4	3-6-8	5-0-2	6-10-8	10-3-13
2x4 SP No. 3 / Stud	24" O.C.	2-9-11	2-10-11	4-1-1	5-7-6	8-5-1

* Diagonal braces over 6'-3" require a 2x4 T-Brace attached to one edge. Diagonal braces over 12'-6" require 2x4 I-braces attached to both edges. Fasten T and I braces to narrow edge of diagonal brace with 10d nails 8" o.c., with 3" minimum end distance. Brace must cover 90% of diagonal length.

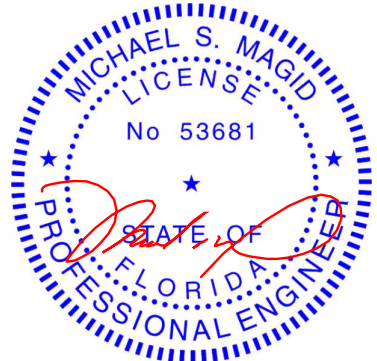

Michael S. Magid PE No.53681
MiTek USA, Inc. FL Cert 6634
6904 Parke East Blvd. Tampa FL 33610
Date:

May 17, 2021

MAX MEAN ROOF HEIGHT = 30 FEET
CATEGORY II BUILDING
EXPOSURE D
ASCE 7-98, ASCE 7-02, ASCE 7-05 130 MPH
ASCE 7-10, ASCE 7-16 160 MPH
DURATION OF LOAD INCREASE : 1.60

STUD DESIGN IS BASED ON COMPONENTS AND CLADDING.
CONNECTION OF BRACING IS BASED ON MWFRS.

WARNING - Verify design parameters and READ NOTES ON THIS AND INCLUDED MITEK REFERENCE PAGE MII-7473 rev. 5/19/2020 BEFORE USE.
Design valid for use only with MiTek® connectors. This design is based only upon parameters shown, and is for an individual building component, not a truss system. Before use, the building designer must verify the applicability of design parameters and properly incorporate this design into the overall building design. Bracing indicated is to prevent buckling of individual truss web and/or chord members only. Additional temporary and permanent bracing is always required for stability and to prevent collapse with possible personal injury and property damage. For general guidance regarding the fabrication, storage, delivery, erection and bracing of trusses and truss systems, see **ANSI/TPI1 Quality Criteria, DSB-89 and BCSI Building Component Safety Information** available from Truss Plate Institute, 2670 Crain Highway, Suite 203 Waldorf, MD 20601



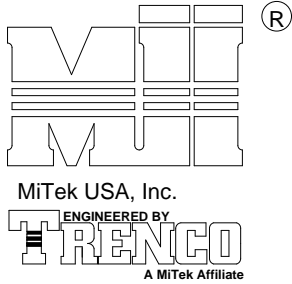

ALTERNATE DIAGONAL BRACING TO THE BOTTOM CHORD

IT IS THE RESPONSIBILITY OF THE BLDG DESIGNER OR THE PROJECT ENGINEER/ARCHTect TO DESIGN THE CEILING DIAPHRAGM AND ITS ATTACHMENT TO THE TRUSSES TO RESIST ALL OUT OF PLANE LOADS THAT MAY RESULT FROM THE BRACING OF THE GABLE ENDS

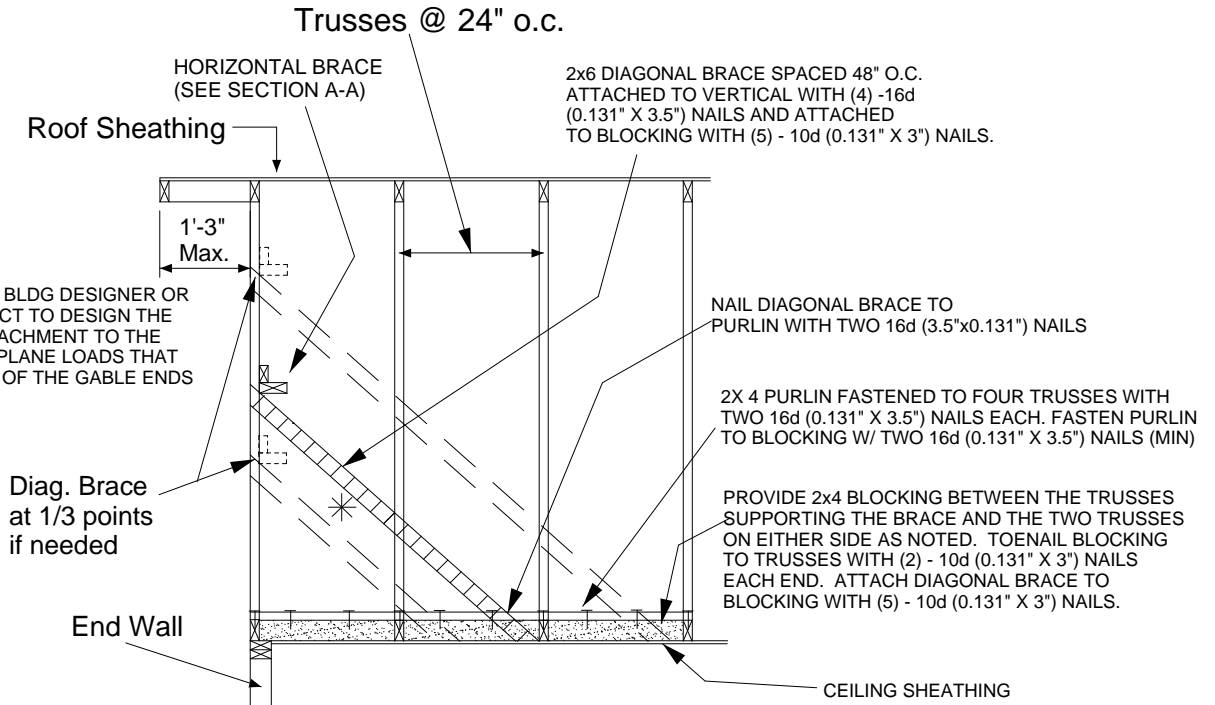

BRACING REQUIREMENTS FOR STRUCTURAL GABLE TRUSSES

STRUCTURAL GABLE TRUSSES MAY BE BRACED AS NOTED:

- METHOD 1 : ATTACH A MATCHING GABLE TRUSS TO THE INSIDE FACE OF THE STRUCTURAL GABLE AND FASTEN PER THE FOLLOWING NAILING SCHEDULE.
- METHOD 2 : ATTACH 2X _ SCABS TO THE FACE OF EACH VERTICAL MEMBER ON THE STRUCTURAL GABLE PER THE FOLLOWING NAILING SCHEDULE. SCABS ARE TO BE OF THE SAME SIZE, GRADE AND SPECIES AS THE TRUSS VERTICALS

NAILING SCHEDULE:

- FOR WIND SPEEDS 120 MPH (ASCE 7-98, 02, 05), 150 MPH (ASCE 7-10, 16) OR LESS, NAIL ALL MEMBERS WITH ONE ROW OF 10d (0.131" X 3") NAILS SPACED 6" O.C.
- FOR WIND SPEEDS 120-150 MPH (ASCE 7-98, 02, 05), 150-190 MPH (ASCE 7-10, 16) NAIL ALL MEMBERS WITH TWO ROWS OF 10d (0.131" X 3") NAILS SPACED 6" O.C. (2X 4 STUDS MINIMUM)

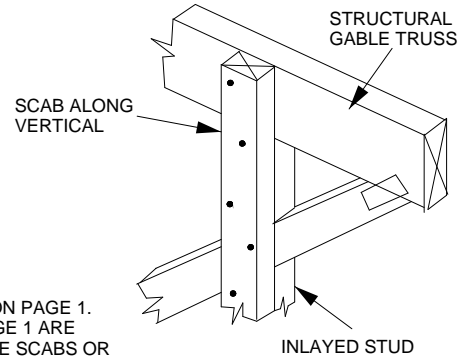

MAXIMUM STUD LENGTHS ARE LISTED ON PAGE 1. ALL BRACING METHODS SHOWN ON PAGE 1 ARE VALID AND ARE TO BE FASTENED TO THE SCABS OR VERTICAL STUDS OF THE STANDARD GABLE TRUSS ON THE INTERIOR SIDE OF THE STRUCTURE.

STRUCTURAL GABLE TRUSS

AN ADEQUATE DIAPHRAGM OR OTHER METHOD OF BRACING MUST BE PRESENT TO PROVIDE FULL LATERAL SUPPORT OF THE BOTTOM CHORD TO RESIST ALL OUT OF PLANE LOADS. THE BRACING SHOWN IN THIS DETAIL IS FOR THE VERTICAL/STUDS ONLY.

NOTE : THIS DETAIL IS TO BE USED ONLY FOR STRUCTURAL GABLES WITH INLAYED STUDS. TRUSSES WITHOUT INLAYED STUDS ARE NOT ADDRESSED HERE.

STANDARD GABLE TRUSS

WARNING - Verify design parameters and READ NOTES ON THIS AND INCLUDED MITEK REFERENCE PAGE MII-7473 rev. 5/19/2020 BEFORE USE.

Design valid for use only with MiTek® connectors. This design is based only upon parameters shown, and is for an individual building component, not a truss system. Before use, the building designer must verify the applicability of design parameters and properly incorporate this design into the overall building design. Bracing indicated is to prevent buckling of individual truss web and/or chord members only. Additional temporary and permanent bracing is always required for stability and to prevent collapse with possible personal injury and property damage. For general guidance regarding the fabrication, storage, delivery, erection and bracing of trusses and truss systems, see

ANSI/TPI1 Quality Criteria, DSB-89 and BCSI Building Component

Safety Information available from Truss Plate Institute, 2670 Crain Highway, Suite 203 Waldorf, MD 20601



6904 Parke East Blvd.
Tampa, FL 36610

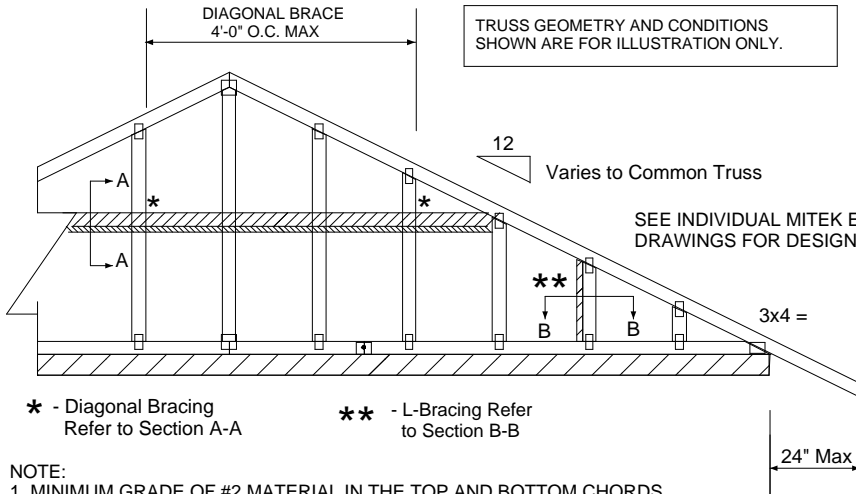
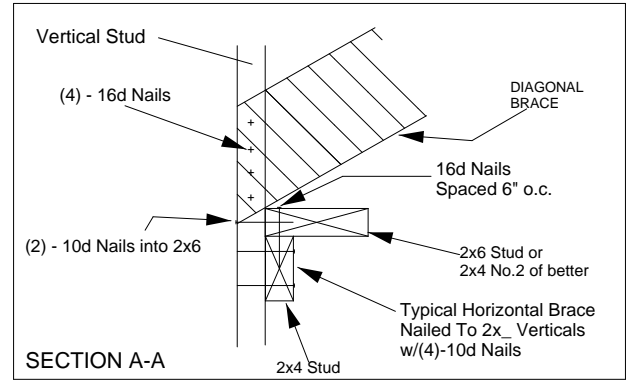
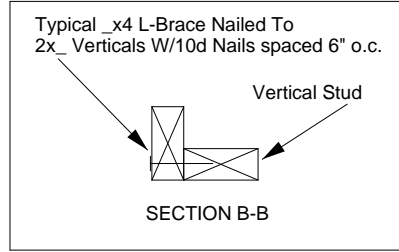
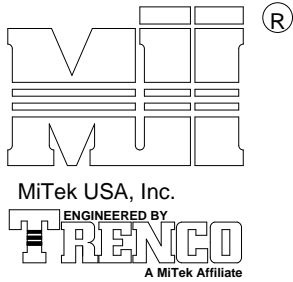

PROVIDE 2x4 BLOCKING BETWEEN THE FIRST TWO TRUSSES AS NOTED. TOENAIL BLOCKING TO TRUSSES WITH (2) - 10d NAILS AT EACH END. ATTACH DIAGONAL BRACE TO BLOCKING WITH (5) - 10d NAILS.

(4) - 8d (0.131" X 2.5") NAILS MINIMUM, PLYWOOD SHEATHING TO 2x4 STD SPF BLOCK

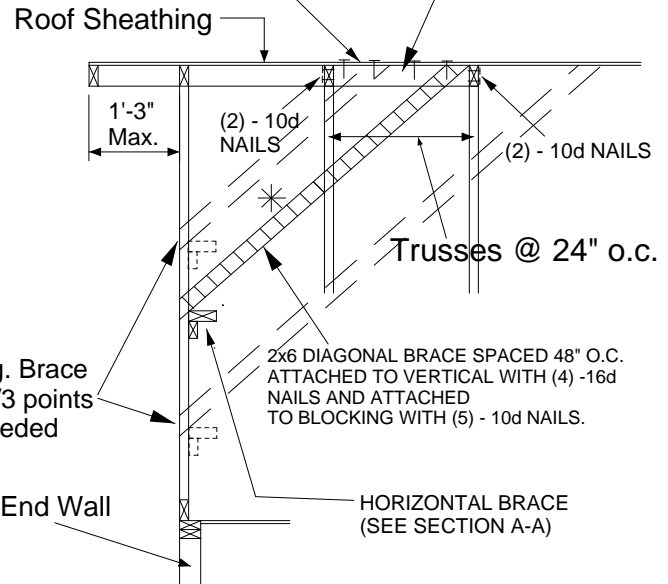

* - Diagonal Bracing Refer to Section A-A
 ** - L-Bracing Refer to Section B-B

- NOTE:
- MINIMUM GRADE OF #2 MATERIAL IN THE TOP AND BOTTOM CHORDS.
 - CONNECTION BETWEEN BOTTOM CHORD OF GABLE END TRUSS AND WALL TO BE PROVIDED BY PROJECT ENGINEER OR ARCHITECT.
 - BRACING SHOWN IS FOR INDIVIDUAL TRUSS ONLY. CONSULT BLDG. ARCHITECT OR ENGINEER FOR TEMPORARY AND PERMANENT BRACING OF ROOF SYSTEM.
 - "L" BRACES SPECIFIED ARE TO BE FULL LENGTH. GRADES: 1x4 SRB OR 2x4 STUD OR BETTER WITH ONE ROW OF 10d NAILS SPACED 6" O.C.
 - DIAGONAL BRACE TO BE APPROXIMATELY 45 DEGREES TO ROOF DIAPHRAM AT 4'-0" O.C.
 - CONSTRUCT HORIZONTAL BRACE CONNECTING A 2x6 STUD AND A 2x4 STUD AS SHOWN WITH 16d NAILS SPACED 6" O.C. HORIZONTAL BRACE TO BE LOCATED AT THE MIDSPAN OF THE LONGEST STUD. ATTACH TO VERTICAL STUDS WITH (4) 10d NAILS THROUGH 2x4. (REFER TO SECTION A-A)
 - GABLE STUD DEFLECTION MEETS OR EXCEEDS L/240.
 - THIS DETAIL DOES NOT APPLY TO STRUCTURAL GABLES.
 - DO NOT USE FLAT BOTTOM CHORD GABLES NEXT TO SCISSOR TYPE TRUSSES.
 - SOUTHERN PINE LUMBER DESIGN VALUES ARE THOSE EFFECTIVE 06-01-13 BY SPIB/ALSC.
 - NAILS DESIGNATED 10d ARE (0.131" X 3") AND NAILS DESIGNATED 16d ARE (0.131" X 3.5")

Minimum Stud Size Species and Grade	Stud Spacing	Without Brace	1x4 L-Brace	2x4 L-Brace	DIAGONAL BRACE	2 DIAGONAL BRACES AT 1/3 POINTS
			Maximum Stud Length			
2x4 SP No. 3 / Stud	12" O.C.	4-0-7	4-5-6	6-3-8	8-0-15	12-1-6
2x4 SP No. 3 / Stud	16" O.C.	3-8-0	3-10-4	5-5-6	7-4-1	11-0-1
2x4 SP No. 3 / Stud	24" O.C.	3-0-10	3-1-12	4-5-6	6-1-5	9-1-15

* Diagonal braces over 6'-3" require a 2x4 T-Brace attached to one edge. Diagonal braces over 12'-6" require 2x4 I-braces attached to both edges. Fasten T and I braces to narrow edge of diagonal brace with 10d nails 8" o.c., with 3" minimum end distance. Brace must cover 90% of diagonal length.

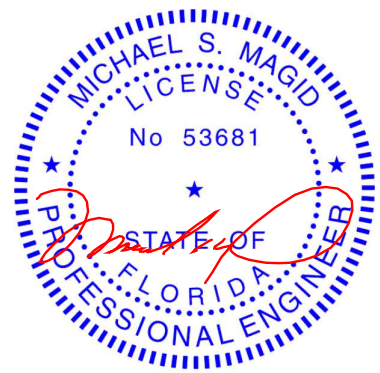

Michael S. Magid PE No.53681
 MiTek USA, Inc. FL Cert 6634
 6904 Parke East Blvd. Tampa FL 33610
 Date:

May 17, 2021

MAX MEAN ROOF HEIGHT = 30 FEET
 CATEGORY II BUILDING
 EXPOSURE B or C
 ASCE 7-98, ASCE 7-02, ASCE 7-05 130 MPH
 ASCE 7-10, ASCE 7-16 160 MPH
 DURATION OF LOAD INCREASE : 1.60

STUD DESIGN IS BASED ON COMPONENTS AND CLADDING.
 CONNECTION OF BRACING IS BASED ON MWFRS.

WARNING - verify design parameters and READ NOTES ON THIS AND INCLUDED MITEK REFERENCE PAGE MII-7473 rev. 5/19/2020 BEFORE USE.
 Design valid for use only with MiTek® connectors. This design is based only upon parameters shown, and is for an individual building component, not a truss system. Before use, the building designer must verify the applicability of design parameters and properly incorporate this design into the overall building design. Bracing indicated is to prevent buckling of individual truss web and/or chord members only. Additional temporary and permanent bracing is always required for stability and to prevent collapse with possible personal injury and property damage. For general guidance regarding the fabrication, storage, delivery, erection and bracing of trusses and truss systems, see **ANSI/TPI1 Quality Criteria, DSB-89 and BCSI Building Component Safety Information** available from Truss Plate Institute, 2670 Crain Highway, Suite 203 Waldorf, MD 20601



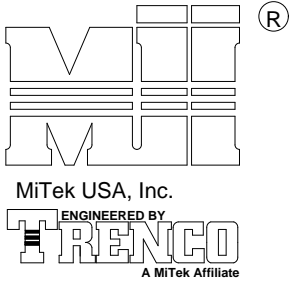

ALTERNATE DIAGONAL BRACING TO THE BOTTOM CHORD

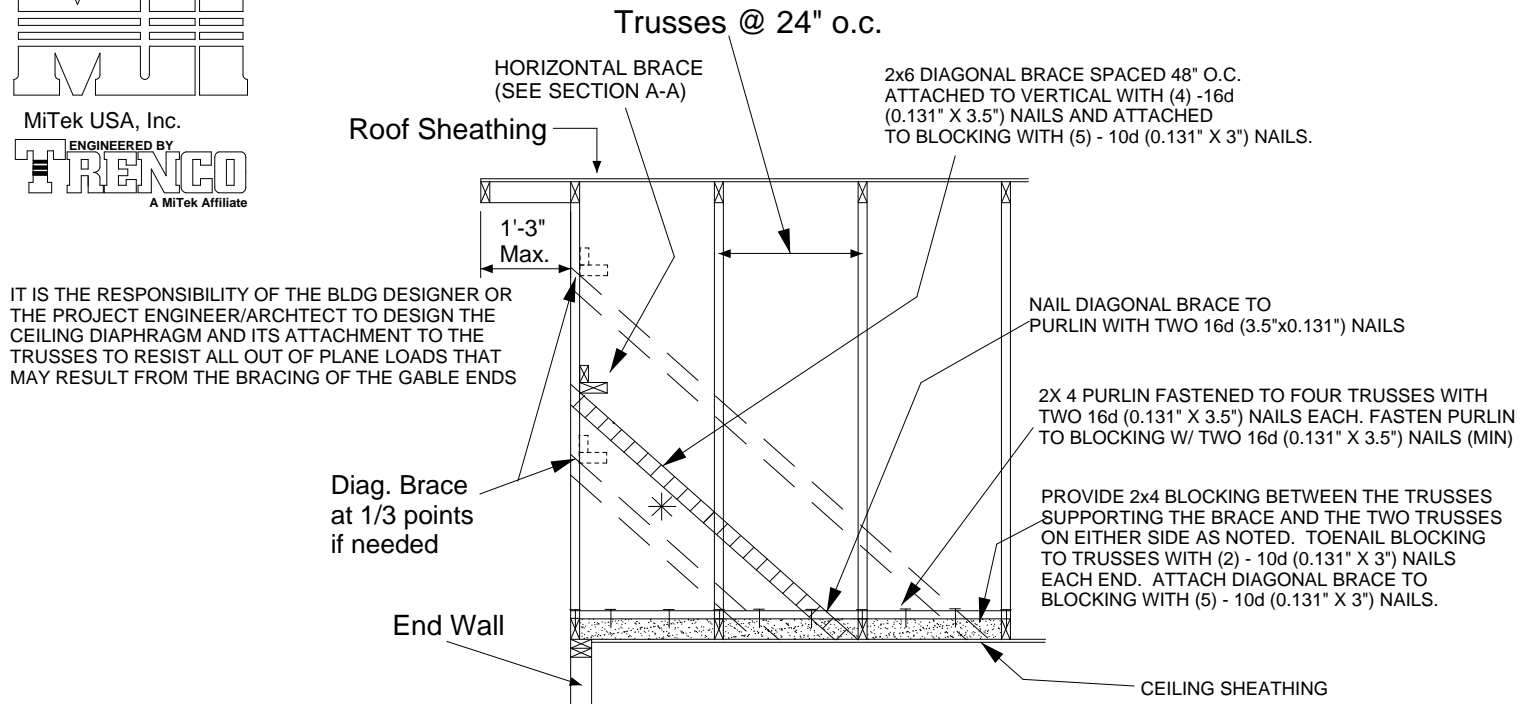

IT IS THE RESPONSIBILITY OF THE BLDG DESIGNER OR THE PROJECT ENGINEER/ARCHTTECT TO DESIGN THE CEILING DIAPHRAGM AND ITS ATTACHMENT TO THE TRUSSES TO RESIST ALL OUT OF PLANE LOADS THAT MAY RESULT FROM THE BRACING OF THE GABLE ENDS

BRACING REQUIREMENTS FOR STRUCTURAL GABLE TRUSSES

- STRUCTURAL GABLE TRUSSES MAY BE BRACED AS NOTED:
- METHOD 1 : ATTACH A MATCHING GABLE TRUSS TO THE INSIDE FACE OF THE STRUCTURAL GABLE AND FASTEN PER THE FOLLOWING NAILING SCHEDULE.
 - METHOD 2 : ATTACH 2X _ SCABS TO THE FACE OF EACH VERTICAL MEMBER ON THE STRUCTURAL GABLE PER THE FOLLOWING NAILING SCHEDULE. SCABS ARE TO BE OF THE SAME SIZE, GRADE AND SPECIES AS THE TRUSS VERTICALS
- NAILING SCHEDULE:
- FOR WIND SPEEDS 120 MPH (ASCE 7-98, 02, 05), 150 MPH (ASCE 7-10, 16) OR LESS, NAIL ALL MEMBERS WITH ONE ROW OF 10d (0.131" X 3") NAILS SPACED 6" O.C.
 - FOR WIND SPEEDS 120-150 MPH (ASCE 7-98, 02, 05), 150-190 MPH (ASCE 7-10, 16) NAIL ALL MEMBERS WITH TWO ROWS OF 10d (0.131" X 3") NAILS SPACED 6" O.C. (2X 4 STUDS MINIMUM)

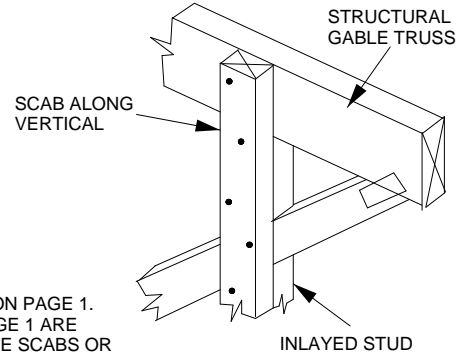

MAXIMUM STUD LENGTHS ARE LISTED ON PAGE 1. ALL BRACING METHODS SHOWN ON PAGE 1 ARE VALID AND ARE TO BE FASTENED TO THE SCABS OR VERTICAL STUDS OF THE STANDARD GABLE TRUSS ON THE INTERIOR SIDE OF THE STRUCTURE.

AN ADEQUATE DIAPHRAGM OR OTHER METHOD OF BRACING MUST BE PRESENT TO PROVIDE FULL LATERAL SUPPORT OF THE BOTTOM CHORD TO RESIST ALL OUT OF PLANE LOADS. THE BRACING SHOWN IN THIS DETAIL IS FOR THE VERTICAL/STUDS ONLY.

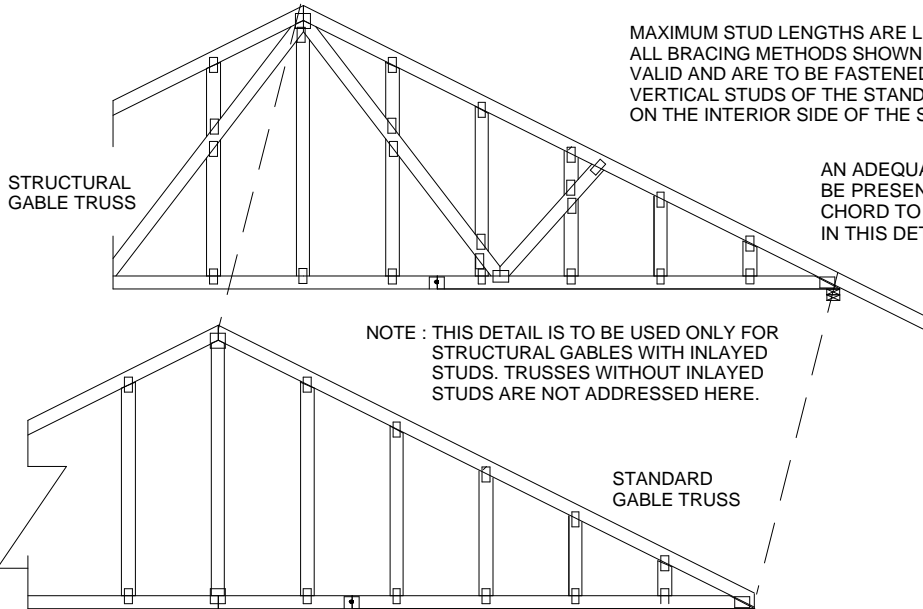

WARNING - Verify design parameters and READ NOTES ON THIS AND INCLUDED MITEK REFERENCE PAGE MII-7473 rev. 5/19/2020 BEFORE USE.

Design valid for use only with MiTek® connectors. This design is based only upon parameters shown, and is for an individual building component, not a truss system. Before use, the building designer must verify the applicability of design parameters and properly incorporate this design into the overall building design. Bracing indicated is to prevent buckling of individual truss web and/or chord members only. Additional temporary and permanent bracing is always required for stability and to prevent collapse with possible personal injury and property damage. For general guidance regarding the fabrication, storage, delivery, erection and bracing of trusses and truss systems, see

ANSI/TPI1 Quality Criteria, DSB-89 and BCSI Building Component

Safety Information available from Truss Plate Institute, 2670 Crain Highway, Suite 203 Waldorf, MD 20601



6904 Parke East Blvd.
Tampa, FL 36610

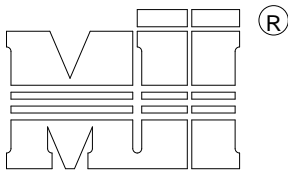

MiTek USA, Inc.

MiTek USA, Inc.
6904 Parke East Blvd.
Tampa, FL 33610-4115
T23949111

May 17, 2021

TO WHOM IT MAY CONCERN:

RE: MiTek 20/20 drawings showing continuous lateral bracing
or "T" bracing on interior webs and chords.

Truss design drawings designed using MiTek 20/20 software show the bracing to be located on a side of the member needing to be braced. The actual side of the member where the brace is to be located does not change the design. If the brace cannot physically be placed on the side of the member as the drawings show, then place the brace on the member at the same location except attach it to the opposite edge.

If we can be of any further assistance in this matter, please feel free to contact our office.

Sincerely,

Michael Magid, PE

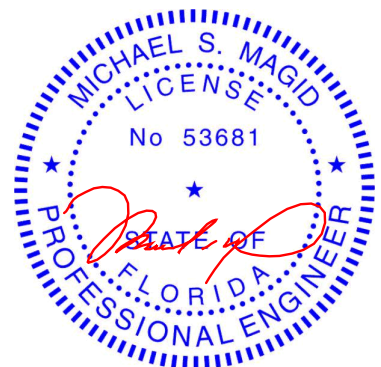

Michael S. Magid PE No.53681
MiTek USA, Inc. FL Cert 6634
6904 Parke East Blvd. Tampa FL 33610
Date:

May 17,2021

WARNING - Verify design parameters and READ NOTES ON THIS AND INCLUDED MITEK REFERENCE PAGE MII-7473 rev. 5/19/2020 BEFORE USE.

Design valid for use only with MiTek® connectors. This design is based only upon parameters shown, and is for an individual building component, not a truss system. Before use, the building designer must verify the applicability of design parameters and properly incorporate this design into the overall building design. Bracing indicated is to prevent buckling of individual truss web and/or chord members only. Additional temporary and permanent bracing is always required for stability and to prevent collapse with possible personal injury and property damage. For general guidance regarding the fabrication, storage, delivery, erection and bracing of trusses and truss systems, see **ANSI/TPI1 Quality Criteria, DSB-89 and BCSI Building Component Safety Information** available from Truss Plate Institute, 2670 Crain Highway, Suite 203 Waldorf, MD 20601



6904 Parke East Blvd.
Tampa, FL 36610

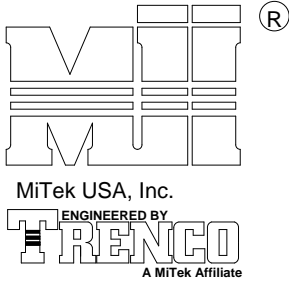

ALTERNATE DIAGONAL BRACING TO THE BOTTOM CHORD

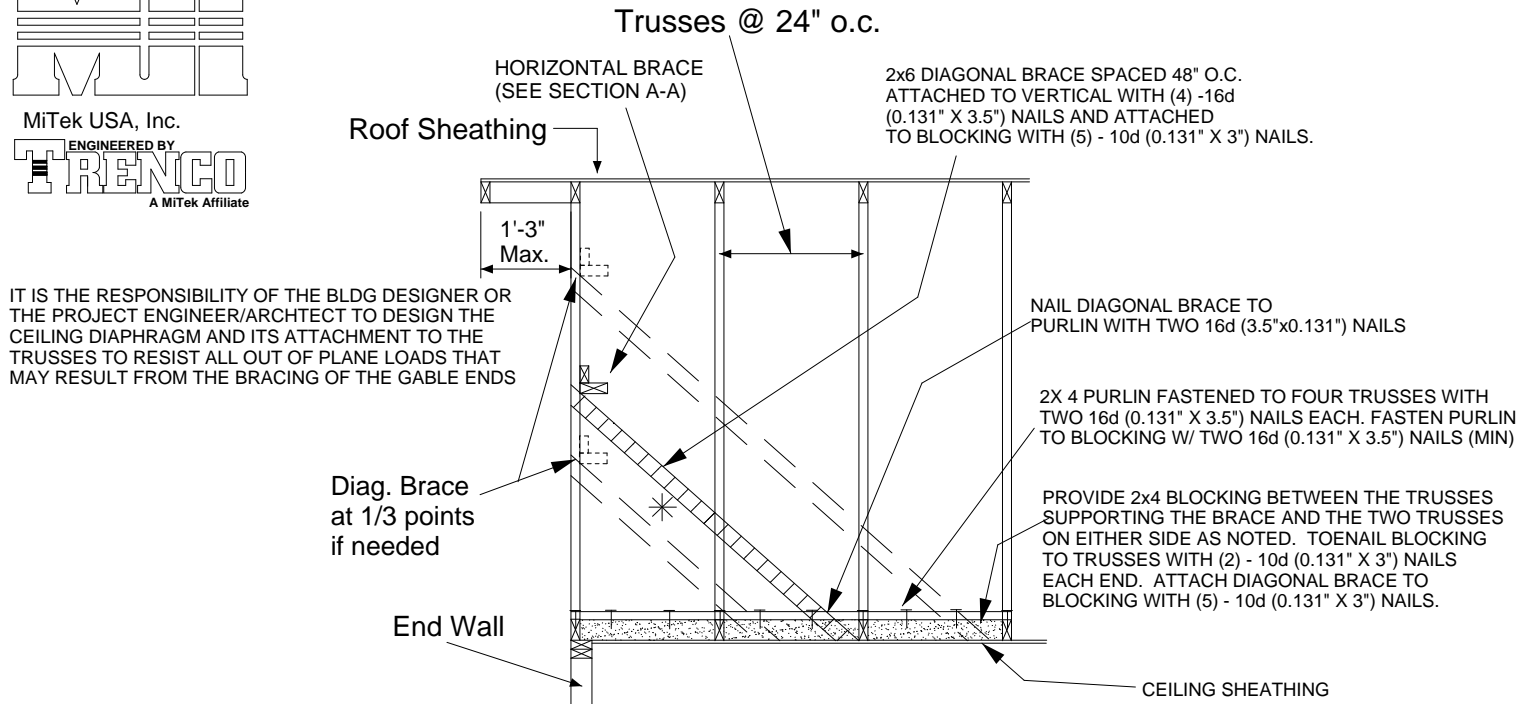

IT IS THE RESPONSIBILITY OF THE BLDG DESIGNER OR THE PROJECT ENGINEER/ARCHTTECT TO DESIGN THE CEILING DIAPHRAGM AND ITS ATTACHMENT TO THE TRUSSES TO RESIST ALL OUT OF PLANE LOADS THAT MAY RESULT FROM THE BRACING OF THE GABLE ENDS

BRACING REQUIREMENTS FOR STRUCTURAL GABLE TRUSSES

- STRUCTURAL GABLE TRUSSES MAY BE BRACED AS NOTED:
- METHOD 1 : ATTACH A MATCHING GABLE TRUSS TO THE INSIDE FACE OF THE STRUCTURAL GABLE AND FASTEN PER THE FOLLOWING NAILING SCHEDULE.
 - METHOD 2 : ATTACH 2X SCABS TO THE FACE OF EACH VERTICAL MEMBER ON THE STRUCTURAL GABLE PER THE FOLLOWING NAILING SCHEDULE. SCABS ARE TO BE OF THE SAME SIZE, GRADE AND SPECIES AS THE TRUSS VERTICALS
- NAILING SCHEDULE:
- FOR WIND SPEEDS 120 MPH (ASCE 7-98, 02, 05), 150 MPH (ASCE 7-10, 16) OR LESS, NAIL ALL MEMBERS WITH ONE ROW OF 10d (0.131" X 3") NAILS SPACED 6" O.C.
 - FOR WIND SPEEDS 120-150 MPH (ASCE 7-98, 02, 05), 150-190 MPH (ASCE 7-10, 16) NAIL ALL MEMBERS WITH TWO ROWS OF 10d (0.131" X 3") NAILS SPACED 6" O.C. (2X 4 STUDS MINIMUM)

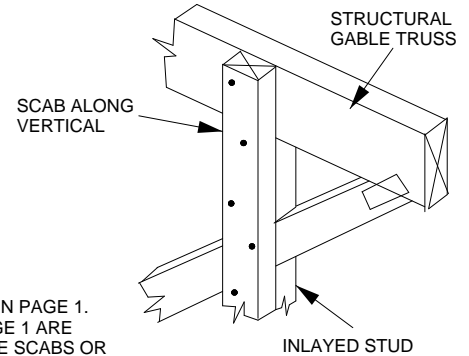

MAXIMUM STUD LENGTHS ARE LISTED ON PAGE 1. ALL BRACING METHODS SHOWN ON PAGE 1 ARE VALID AND ARE TO BE FASTENED TO THE SCABS OR VERTICAL STUDS OF THE STANDARD GABLE TRUSS ON THE INTERIOR SIDE OF THE STRUCTURE.

STRUCTURAL GABLE TRUSS

AN ADEQUATE DIAPHRAGM OR OTHER METHOD OF BRACING MUST BE PRESENT TO PROVIDE FULL LATERAL SUPPORT OF THE BOTTOM CHORD TO RESIST ALL OUT OF PLANE LOADS. THE BRACING SHOWN IN THIS DETAIL IS FOR THE VERTICAL/STUDS ONLY.

NOTE : THIS DETAIL IS TO BE USED ONLY FOR STRUCTURAL GABLES WITH INLAYED STUDS. TRUSSES WITHOUT INLAYED STUDS ARE NOT ADDRESSED HERE.

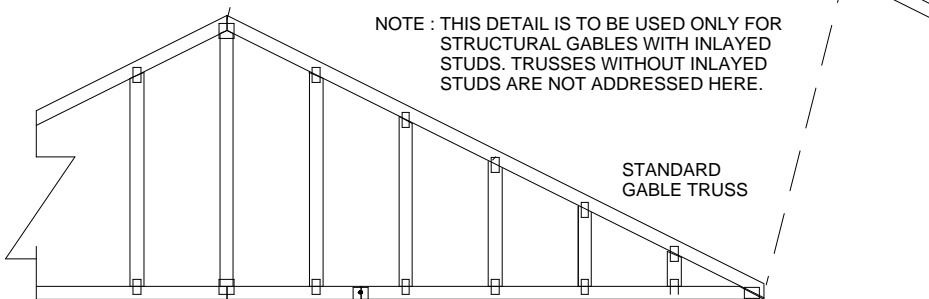

STANDARD GABLE TRUSS

WARNING - Verify design parameters and READ NOTES ON THIS AND INCLUDED MITEK REFERENCE PAGE MII-7473 rev. 5/19/2020 BEFORE USE.

Design valid for use only with MiTek® connectors. This design is based only upon parameters shown, and is for an individual building component, not a truss system. Before use, the building designer must verify the applicability of design parameters and properly incorporate this design into the overall building design. Bracing indicated is to prevent buckling of individual truss web and/or chord members only. Additional temporary and permanent bracing is always required for stability and to prevent collapse with possible personal injury and property damage. For general guidance regarding the fabrication, storage, delivery, erection and bracing of trusses and truss systems, see

ANSI/TPI1 Quality Criteria, DSB-89 and BCSI Building Component

Safety Information available from Truss Plate Institute, 2670 Crain Highway, Suite 203 Waldorf, MD 20601



6904 Parke East Blvd.
Tampa, FL 36610

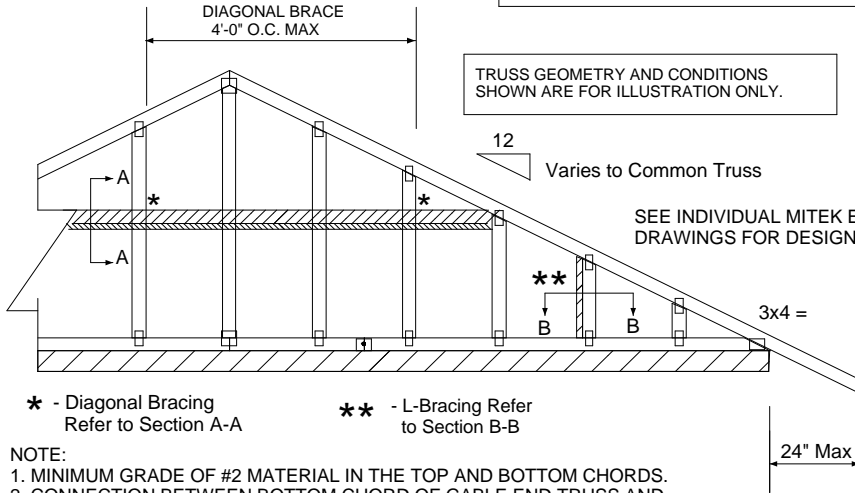
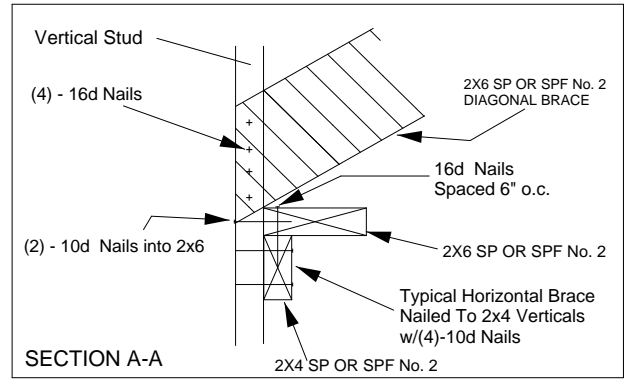
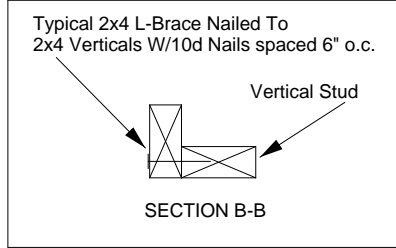
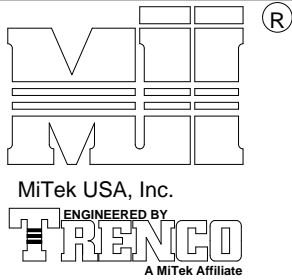

* - Diagonal Bracing Refer to Section A-A
 ** - L-Bracing Refer to Section B-B

- NOTE:
1. MINIMUM GRADE OF #2 MATERIAL IN THE TOP AND BOTTOM CHORDS.
 2. CONNECTION BETWEEN BOTTOM CHORD OF GABLE END TRUSS AND WALL TO BE PROVIDED BY PROJECT ENGINEER OR ARCHITECT.
 3. BRACING SHOWN IS FOR INDIVIDUAL TRUSS ONLY. CONSULT BLDG. ARCHITECT OR ENGINEER FOR TEMPORARY AND PERMANENT BRACING OF ROOF SYSTEM.
 4. "L" BRACES SPECIFIED ARE TO BE FULL LENGTH, SPF or SP No.3 OR BETTER WITH ONE ROW OF 10d NAILS SPACED 6" O.C.
 5. DIAGONAL BRACE TO BE APPROXIMATELY 45 DEGREES TO ROOF DIAPHRAM AT 4'-0" O.C.
 6. CONSTRUCT HORIZONTAL BRACE CONNECTING A 2x6 AND A 2x4 AS SHOWN WITH 16d NAILS SPACED 6" O.C. HORIZONTAL BRACE TO BE LOCATED AT THE MIDSPAN OF THE LONGEST GABLE STUD. ATTACH TO VERTICAL GABLE STUDS WITH (4) 10d NAILS THROUGH 2x4. (REFER TO SECTION A-A)
 7. GABLE STUD DEFLECTION MEETS OR EXCEEDS L/240.
 8. THIS DETAIL DOES NOT APPLY TO STRUCTURAL GABLES.
 9. DO NOT USE FLAT BOTTOM CHORD GABLES NEXT TO SCISSOR TYPE TRUSSES.
 10. SOUTHERN PINE LUMBER DESIGN VALUES ARE THOSE EFFECTIVE 06-01-13 BY SPIB/ALSC.
 11. NAILS DESIGNATED 10d ARE (0.131" X 3") AND NAILS DESIGNATED 16d ARE (0.131" X 3.5")

PROVIDE 2x4 BLOCKING BETWEEN THE FIRST TWO TRUSSES AS NOTED. TOENAIL BLOCKING TO TRUSSES WITH (2) - 10d NAILS AT EACH END. ATTACH DIAGONAL BRACE TO BLOCKING WITH (5) - 10d NAILS.

(4) - 8d (0.131" X 2.5") NAILS MINIMUM, PLYWOOD SHEATHING TO 2x4 STD SPF BLOCK

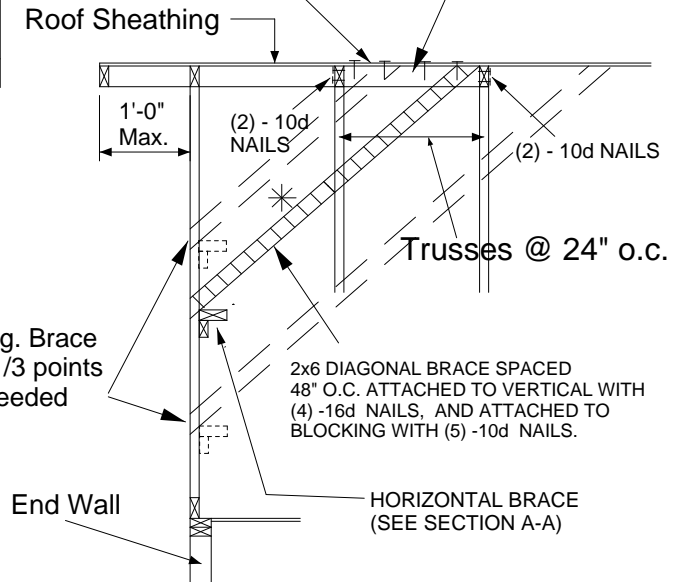

Minimum Stud Size Species and Grade	Stud Spacing	Without Brace	2x4 L-Brace	DIAGONAL BRACE	2 DIAGONAL BRACES AT 1/3 POINTS
2x4 SP No. 3 / Stud	12" O.C.	3-9-7	5-8-8	6-11-1	11-4-4
2x4 SP No. 3 / Stud	16" O.C.	3-4-12	4-11-15	6-9-8	10-2-3
2x4 SP No. 3 / Stud	24" O.C.	2-9-4	4-0-7	5-6-8	8-3-13
2x4 SP No. 2	12" O.C.	3-11-13	5-8-8	6-11-1	11-11-7
2x4 SP No. 2	16" O.C.	3-7-7	4-11-5	6-11-1	10-10-5
2x4 SP No. 2	24" O.C.	3-1-15	4-0-7	6-3-14	9-5-14

* Diagonal braces over 6'-3" require a 2x4 T-Brace attached to one edge. Diagonal braces over 12'-6" require 2x4 I-braces attached to both edges. Fasten T and I braces to narrow edge of diagonal brace with 10d nails 6" o.c., with 3" minimum end distance. Brace must cover 90% of diagonal length. T or I braces must be 2x4 SPF No. 2 or SP No. 2.

MAX MEAN ROOF HEIGHT = 30 FEET
 EXPOSURE D
 ASCE 7-10, ASCE 7-16 170 MPH
 DURATION OF LOAD INCREASE : 1.60

STUD DESIGN IS BASED ON COMPONENTS AND CLADDING.
 CONNECTION OF BRACING IS BASED ON MWFRS.

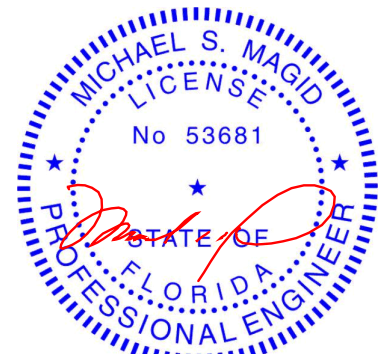

Michael S. Magid PE No.53681
 MiTek USA, Inc. FL Cert 6634
 6904 Parke East Blvd. Tampa FL 33610
 Date:

May 17, 2021

WARNING - Verify design parameters and READ NOTES ON THIS AND INCLUDED MITEK REFERENCE PAGE MII-7473 rev. 5/19/2020 BEFORE USE.
 Design valid for use only with MiTek® connectors. This design is based only upon parameters shown, and is for an individual building component, not a truss system. Before use, the building designer must verify the applicability of design parameters and properly incorporate this design into the overall building design. Bracing indicated is to prevent buckling of individual truss web and/or chord members only. Additional temporary and permanent bracing is always required for stability and to prevent collapse with possible personal injury and property damage. For general guidance regarding the fabrication, storage, delivery, erection and bracing of trusses and truss systems, see ANSIT/TP1 Quality Criteria, DSB-89 and BCSI Building Component Safety Information available from Truss Plate Institute, 2670 Crain Highway, Suite 203 Waldorf, MD 20601



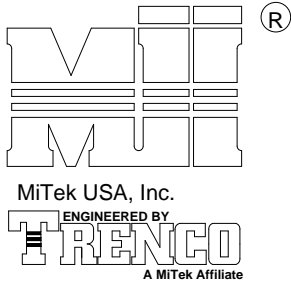

ALTERNATE DIAGONAL BRACING TO THE BOTTOM CHORD

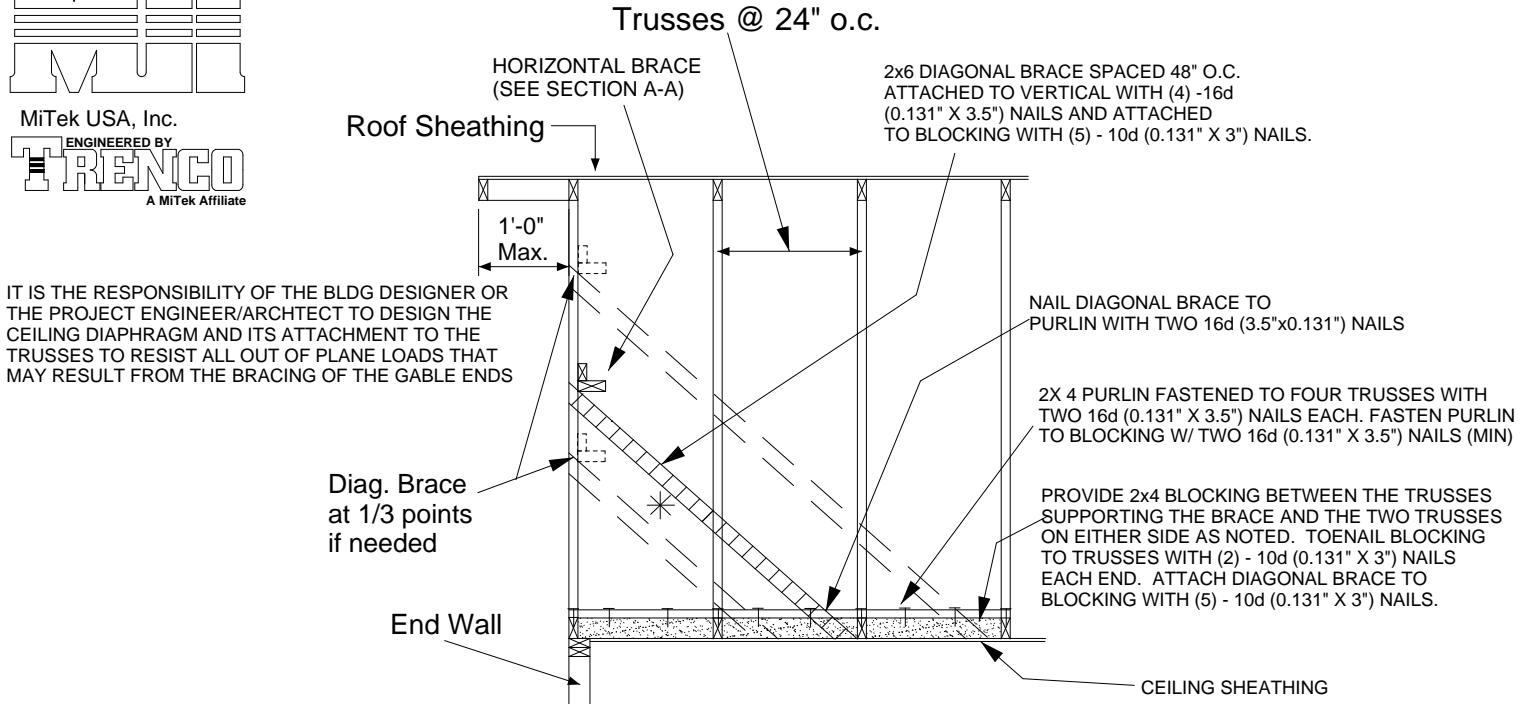

IT IS THE RESPONSIBILITY OF THE BLDG DESIGNER OR THE PROJECT ENGINEER/ARCHTCT TO DESIGN THE CEILING DIAPHRAGM AND ITS ATTACHMENT TO THE TRUSSES TO RESIST ALL OUT OF PLANE LOADS THAT MAY RESULT FROM THE BRACING OF THE GABLE ENDS

BRACING REQUIREMENTS FOR STRUCTURAL GABLE TRUSSES

STRUCTURAL GABLE TRUSSES MAY BE BRACED AS NOTED:

METHOD 1 : ATTACH A MATCHING GABLE TRUSS TO THE INSIDE FACE OF THE STRUCTURAL GABLE AND FASTEN PER THE FOLLOWING NAILING SCHEDULE.

METHOD 2 : ATTACH 2X SCABS TO THE FACE OF EACH VERTICAL MEMBER ON THE STRUCTURAL GABLE PER THE FOLLOWING NAILING SCHEDULE. SCABS ARE TO BE OF THE SAME SIZE, GRADE AND SPECIES AS THE TRUSS VERTICALS

NAILING SCHEDULE:

- FOR WIND SPEEDS 120 MPH (ASCE 7-98, 02, 05), 150 MPH (ASCE 7-10, 16) OR LESS, NAIL ALL MEMBERS WITH ONE ROW OF 10d (0.131" X 3") NAILS SPACED 6" O.C.
- FOR WIND SPEEDS 120-150 MPH (ASCE 7-98, 02, 05), 150-190 MPH (ASCE 7-10, 16) NAIL ALL MEMBERS WITH TWO ROWS OF 10d (0.131" X 3") NAILS SPACED 6" O.C. (2X 4 STUDS MINIMUM)

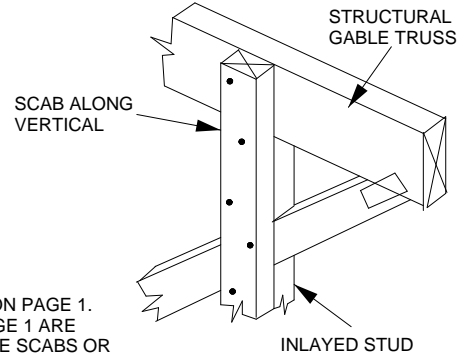

MAXIMUM STUD LENGTHS ARE LISTED ON PAGE 1. ALL BRACING METHODS SHOWN ON PAGE 1 ARE VALID AND ARE TO BE FASTENED TO THE SCABS OR VERTICAL STUDS OF THE STANDARD GABLE TRUSS ON THE INTERIOR SIDE OF THE STRUCTURE.

STRUCTURAL GABLE TRUSS

AN ADEQUATE DIAPHRAGM OR OTHER METHOD OF BRACING MUST BE PRESENT TO PROVIDE FULL LATERAL SUPPORT OF THE BOTTOM CHORD TO RESIST ALL OUT OF PLANE LOADS. THE BRACING SHOWN IN THIS DETAIL IS FOR THE VERTICAL/STUDS ONLY.

NOTE : THIS DETAIL IS TO BE USED ONLY FOR STRUCTURAL GABLES WITH INLAYED STUDS. TRUSSES WITHOUT INLAYED STUDS ARE NOT ADDRESSED HERE.

STANDARD GABLE TRUSS

WARNING - Verify design parameters and READ NOTES ON THIS AND INCLUDED MITEK REFERENCE PAGE MII-7473 rev. 5/19/2020 BEFORE USE.

Design valid for use only with MiTek® connectors. This design is based only upon parameters shown, and is for an individual building component, not a truss system. Before use, the building designer must verify the applicability of design parameters and properly incorporate this design into the overall building design. Bracing indicated is to prevent buckling of individual truss web and/or chord members only. Additional temporary and permanent bracing is always required for stability and to prevent collapse with possible personal injury and property damage. For general guidance regarding the fabrication, storage, delivery, erection and bracing of trusses and truss systems, see

ANSI/TPI1 Quality Criteria, DSB-89 and BCSI Building Component

Safety Information available from Truss Plate Institute, 2670 Crain Highway, Suite 203 Waldorf, MD 20601



6904 Parke East Blvd.
Tampa, FL 36610

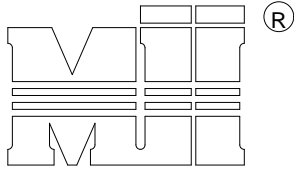

A MiTek Affiliate
DIAGONAL BRACE
4'-0" O.C. MAX

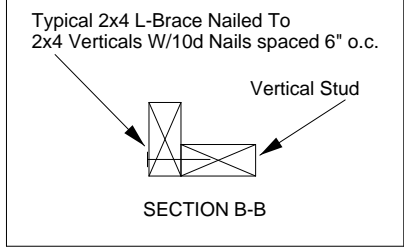

TRUSS GEOMETRY AND CONDITIONS SHOWN ARE FOR ILLUSTRATION ONLY.

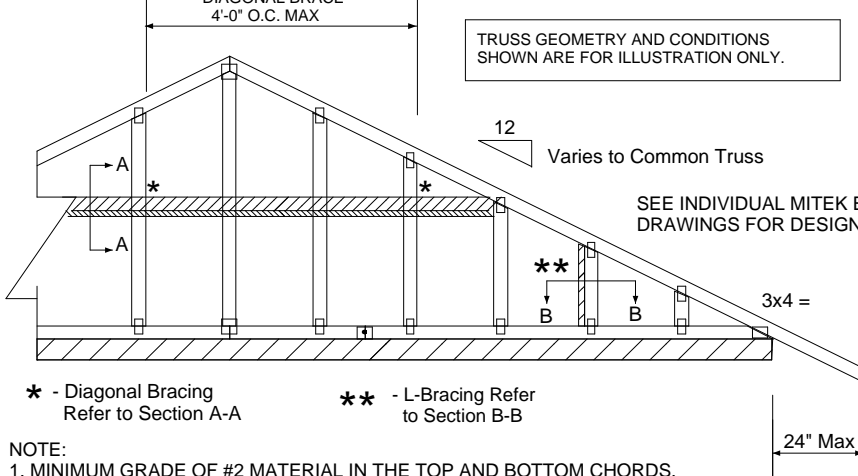

* - Diagonal Bracing Refer to Section A-A
** - L-Bracing Refer to Section B-B

- NOTE:
1. MINIMUM GRADE OF #2 MATERIAL IN THE TOP AND BOTTOM CHORDS.
 2. CONNECTION BETWEEN BOTTOM CHORD OF GABLE END TRUSS AND WALL TO BE PROVIDED BY PROJECT ENGINEER OR ARCHITECT.
 3. BRACING SHOWN IS FOR INDIVIDUAL TRUSS ONLY. CONSULT BLDG. ARCHITECT OR ENGINEER FOR TEMPORARY AND PERMANENT BRACING OF ROOF SYSTEM.
 4. "L" BRACES SPECIFIED ARE TO BE FULL LENGTH, SPF or SP No.3 OR BETTER WITH ONE ROW OF 10d NAILS SPACED 6" O.C.
 5. DIAGONAL BRACE TO BE APPROXIMATELY 45 DEGREES TO ROOF DIAPHRAM AT 4'-0" O.C.
 6. CONSTRUCT HORIZONTAL BRACE CONNECTING A 2x6 AND A 2x4 AS SHOWN WITH 16d NAILS SPACED 6" O.C. HORIZONTAL BRACE TO BE LOCATED AT THE MIDSPAN OF THE LONGEST GABLE STUD. ATTACH TO VERTICAL GABLE STUDS WITH (4) 10d NAILS THROUGH 2x4. (REFER TO SECTION A-A)
 7. GABLE STUD DEFLECTION MEETS OR EXCEEDS L/240.
 8. THIS DETAIL DOES NOT APPLY TO STRUCTURAL GABLES.
 9. DO NOT USE FLAT BOTTOM CHORD GABLES NEXT TO SCISSOR TYPE TRUSSES.
 10. SOUTHERN PINE LUMBER DESIGN VALUES ARE THOSE EFFECTIVE 06-01-13 BY SPIB/ALSC.
 11. NAILS DESIGNATED 10d ARE (0.131" X 3") AND NAILS DESIGNATED 16d ARE (0.131" X 3.5")

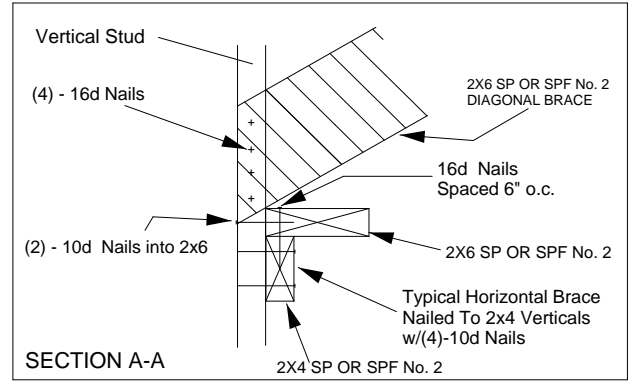

PROVIDE 2x4 BLOCKING BETWEEN THE FIRST TWO TRUSSES AS NOTED. TOENAIL BLOCKING TO TRUSSES WITH (2) - 10d NAILS AT EACH END. ATTACH DIAGONAL BRACE TO BLOCKING WITH (5) - 10d NAILS.

(4) - 8d (0.131" X 2.5") NAILS MINIMUM, PLYWOOD SHEATHING TO 2x4 STD SPF BLOCK

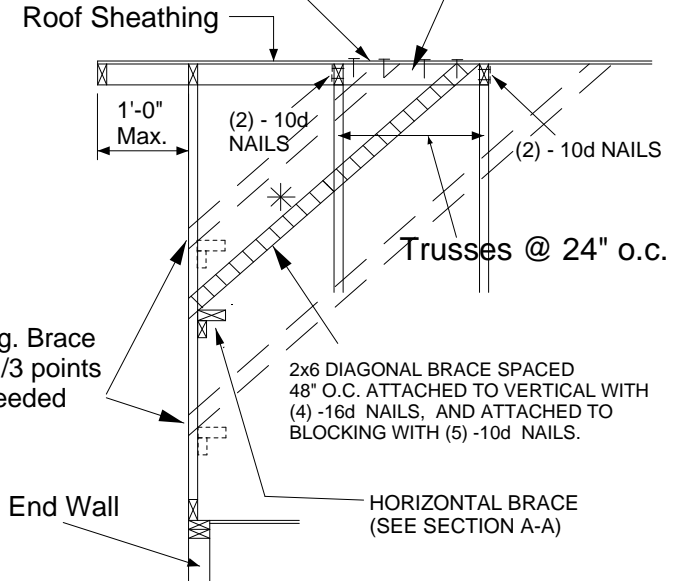

Minimum Stud Size Species and Grade	Stud Spacing	Without Brace	2x4 L-Brace	DIAGONAL BRACE	2 DIAGONAL BRACES AT 1/3 POINTS
2x4 SP No. 3 / Stud	12" O.C.	3-7-12	5-4-11	6-2-1	10-11-3
2x4 SP No. 3 / Stud	16" O.C.	3-2-8	4-8-1	6-2-1	9-7-7
2x4 SP No. 3 / Stud	24" O.C.	2-7-7	3-9-12	5-2-13	7-10-4
2x4 SP No. 2	12" O.C.	3-10-0	5-4-11	6-2-1	11-6-1
2x4 SP No. 2	16" O.C.	3-5-13	4-8-1	6-2-1	10-5-7
2x4 SP No. 2	24" O.C.	3-0-8	3-9-12	6-1-1	9-1-9

* Diagonal braces over 6'-3" require a 2x4 T-Brace attached to one edge. Diagonal braces over 12'-6" require 2x4 I-braces attached to both edges. Fasten T and I braces to narrow edge of diagonal brace with 10d nails 6in o.c., with 3in minimum end distance. Brace must cover 90% of diagonal length. T or I braces must be 2x4 SPF No. 2 or SP No. 2.

MAX MEAN ROOF HEIGHT = 30 FEET
EXPOSURE D
ASCE 7-10, ASCE 7-16 180 MPH
DURATION OF LOAD INCREASE : 1.60

STUD DESIGN IS BASED ON COMPONENTS AND CLADDING.
CONNECTION OF BRACING IS BASED ON MWFRS.

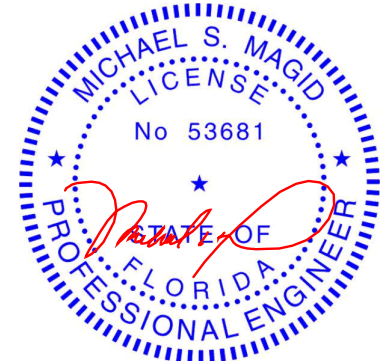

Michael S. Magid PE No.53681
MiTek USA, Inc. FL Cert 6634
6904 Parke East Blvd. Tampa FL 33610
Date:

May 17, 2021

WARNING - Verify design parameters and READ NOTES ON THIS AND INCLUDED MITEK REFERENCE PAGE MII-7473 rev. 5/19/2020 BEFORE USE.
Design valid for use only with MiTek® connectors. This design is based only upon parameters shown, and is for an individual building component, not a truss system. Before use, the building designer must verify the applicability of design parameters and properly incorporate this design into the overall building design. Bracing indicated is to prevent buckling of individual truss web and/or chord members only. Additional temporary and permanent bracing is always required for stability and to prevent collapse with possible personal injury and property damage. For general guidance regarding the fabrication, storage, delivery, erection and bracing of trusses and truss systems, see ANSITP11 Quality Criteria, DSB-89 and BCSI Building Component Safety Information available from Truss Plate Institute, 2670 Crain Highway, Suite 203 Waldorf, MD 20601



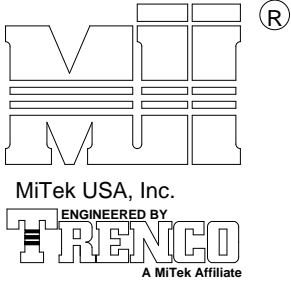

ALTERNATE DIAGONAL BRACING TO THE BOTTOM CHORD

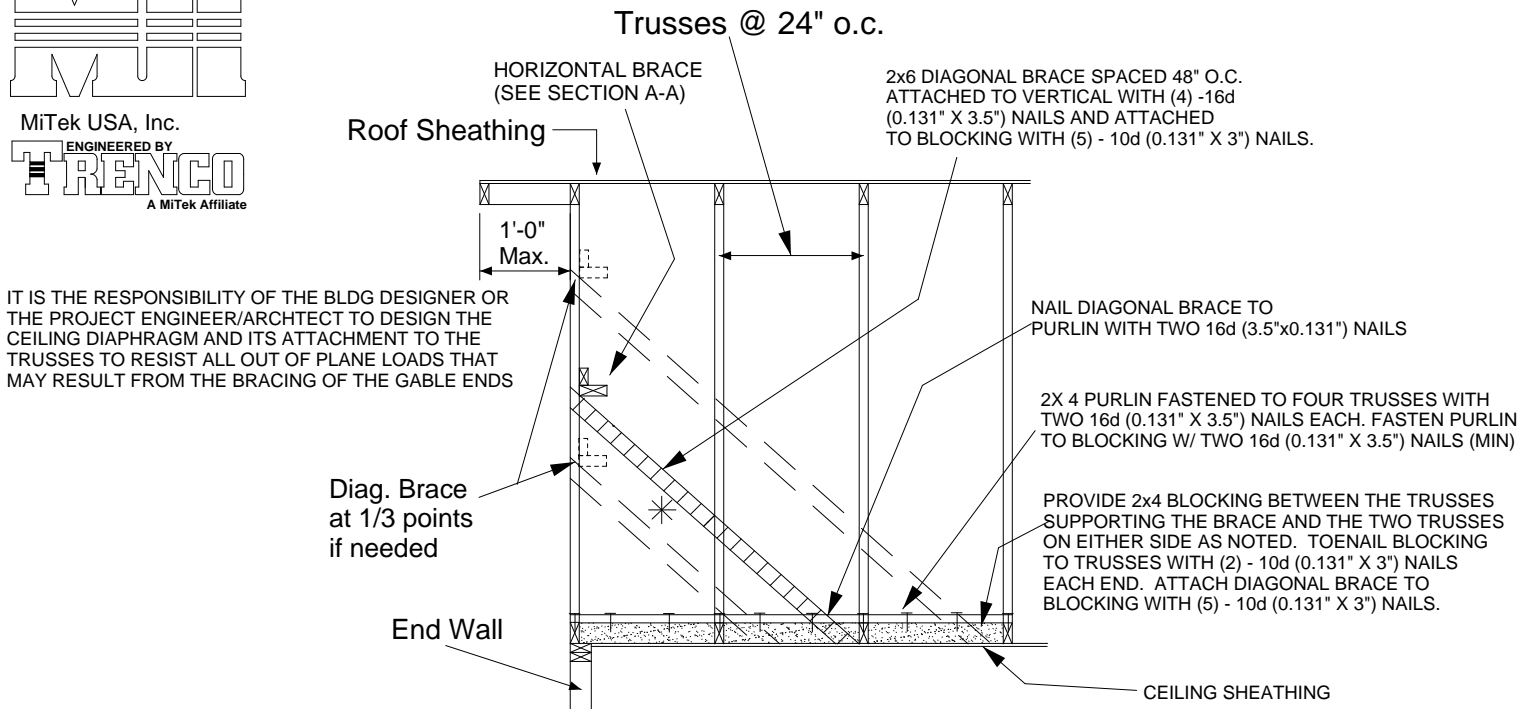

IT IS THE RESPONSIBILITY OF THE BLDG DESIGNER OR THE PROJECT ENGINEER/ARCHTCT TO DESIGN THE CEILING DIAPHRAGM AND ITS ATTACHMENT TO THE TRUSSES TO RESIST ALL OUT OF PLANE LOADS THAT MAY RESULT FROM THE BRACING OF THE GABLE ENDS

BRACING REQUIREMENTS FOR STRUCTURAL GABLE TRUSSES

- STRUCTURAL GABLE TRUSSES MAY BE BRACED AS NOTED:
- METHOD 1 : ATTACH A MATCHING GABLE TRUSS TO THE INSIDE FACE OF THE STRUCTURAL GABLE AND FASTEN PER THE FOLLOWING NAILING SCHEDULE.
 - METHOD 2 : ATTACH 2X _ SCABS TO THE FACE OF EACH VERTICAL MEMBER ON THE STRUCTURAL GABLE PER THE FOLLOWING NAILING SCHEDULE. SCABS ARE TO BE OF THE SAME SIZE, GRADE AND SPECIES AS THE TRUSS VERTICALS
- NAILING SCHEDULE:
- FOR WIND SPEEDS 120 MPH (ASCE 7-98, 02, 05), 150 MPH (ASCE 7-10, 16) OR LESS, NAIL ALL MEMBERS WITH ONE ROW OF 10d (0.131" X 3") NAILS SPACED 6" O.C.
 - FOR WIND SPEEDS 120-150 MPH (ASCE 7-98, 02, 05), 150-190 MPH (ASCE 7-10, 16) NAIL ALL MEMBERS WITH TWO ROWS OF 10d (0.131" X 3") NAILS SPACED 6" O.C. (2X 4 STUDS MINIMUM)

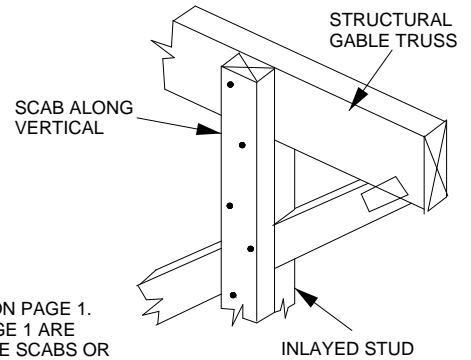

MAXIMUM STUD LENGTHS ARE LISTED ON PAGE 1. ALL BRACING METHODS SHOWN ON PAGE 1 ARE VALID AND ARE TO BE FASTENED TO THE SCABS OR VERTICAL STUDS OF THE STANDARD GABLE TRUSS ON THE INTERIOR SIDE OF THE STRUCTURE.

STRUCTURAL GABLE TRUSS

AN ADEQUATE DIAPHRAGM OR OTHER METHOD OF BRACING MUST BE PRESENT TO PROVIDE FULL LATERAL SUPPORT OF THE BOTTOM CHORD TO RESIST ALL OUT OF PLANE LOADS. THE BRACING SHOWN IN THIS DETAIL IS FOR THE VERTICAL/STUDS ONLY.

NOTE : THIS DETAIL IS TO BE USED ONLY FOR STRUCTURAL GABLES WITH INLAYED STUDS. TRUSSES WITHOUT INLAYED STUDS ARE NOT ADDRESSED HERE.

STANDARD GABLE TRUSS

WARNING - Verify design parameters and READ NOTES ON THIS AND INCLUDED MITEK REFERENCE PAGE MII-7473 rev. 5/19/2020 BEFORE USE.

Design valid for use only with MiTek® connectors. This design is based only upon parameters shown, and is for an individual building component, not a truss system. Before use, the building designer must verify the applicability of design parameters and properly incorporate this design into the overall building design. Bracing indicated is to prevent buckling of individual truss web and/or chord members only. Additional temporary and permanent bracing is always required for stability and to prevent collapse with possible personal injury and property damage. For general guidance regarding the fabrication, storage, delivery, erection and bracing of trusses and truss systems, see

ANSI/TPI1 Quality Criteria, DSB-89 and BCSI Building Component

Safety Information available from Truss Plate Institute, 2670 Crain Highway, Suite 203 Waldorf, MD 20601



6904 Parke East Blvd.
Tampa, FL 36610

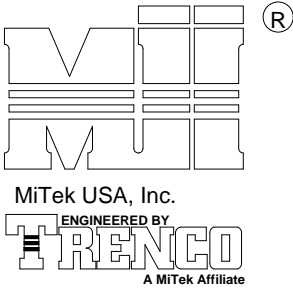

MAXIMUM WIND SPEED = REFER TO NOTES D AND OR E
 MAX MEAN ROOF HEIGHT = 30 FEET
 MAX TRUSS SPACING = 24" O.C.
 CATEGORY II BUILDING
 EXPOSURE B or C
 ENCLOSED BUILDING
 LOADING = 5 PSF TCDL
 ASCE 7-10, ASCE 7-16
 DURATION OF LOAD INCREASE : 1.60

DETAIL IS NOT APPLICABLE FOR TRUSSES TRANSFERRING DRAG LOADS (SHEAR TRUSSES). ADDITIONAL CONSIDERATIONS BY BUILDING ENGINEER/DESIGNER ARE REQUIRED.

- A - PIGGYBACK TRUSS, REFER TO MITEK TRUSS DESIGN DRAWING. SHALL BE CONNECTED TO EACH PURLIN WITH (2) (0.131" X 3.5") TOE-NAILED.
- B - BASE TRUSS, REFER TO MITEK TRUSS DESIGN DRAWING.
- C - PURLINS AT EACH BASE TRUSS JOINT AND A MAXIMUM 24" O.C. UNLESS SPECIFIED CLOSER ON MITEK TRUSS DESIGN DRAWING. CONNECT TO BASE TRUSS WITH (2) (0.131" X 3.5") NAILS EACH.
- D - 2 x ___ X 4'-0" SCAB, SIZE TO MATCH TOP CHORD OF PIGGYBACK TRUSS, MIN GRADE #2, ATTACHED TO ONE FACE, CENTERED ON INTERSECTION, WITH (2) ROWS OF (0.131" X 3") NAILS @ 4" O.C. SCAB MAY BE OMITTED PROVIDED THE TOP CHORD SHEATHING IS CONTINUOUS OVER INTERSECTION AT LEAST 1 FT. IN BOTH DIRECTIONS AND:
 - 1. WIND SPEED OF 115 MPH OR LESS FOR ANY PIGGYBACK SPAN, OR
 - 2. WIND SPEED OF 116 MPH TO 180 MPH WITH A MAXIMUM PIGGYBACK SPAN OF 12 ft.
- E - FOR WIND SPEEDS BETWEEN 116 AND 180 MPH, ATTACH MITEK NP37 20 GA Nail-On PLATES TO EACH FACE OF TRUSSES AT 72" O.C. W/ (4) (0.131" X 1.5") NAILS PER MEMBER. STAGGER NAILS FROM OPPOSING FACES. ENSURE 0.5" NAIL EDGE DISTANCE. (MIN. 2 PAIRS OF PLATES REQ. REGARDLESS OF SPAN)

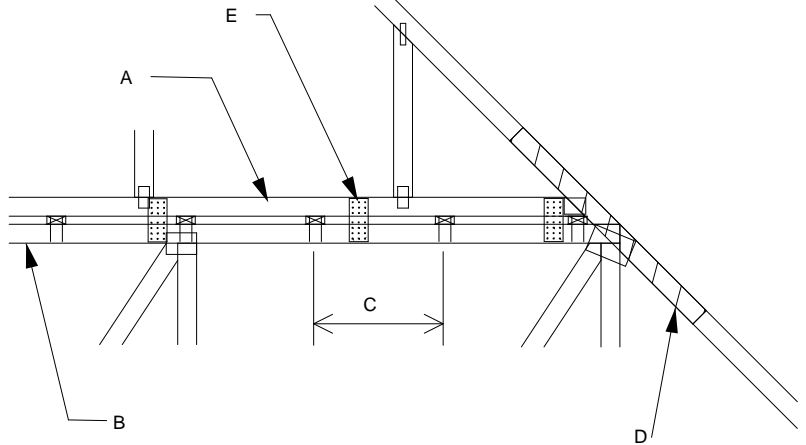

WHEN NO GAP BETWEEN PIGGYBACK AND BASE TRUSS EXISTS:

REPLACE TOE NAILING OF PIGGYBACK TRUSS TO PURLINS WITH Nail-On PLATES AS SHOWN, AND INSTALL PURLINS TO BOTTOM EDGE OF BASE TRUSS TOP CHORD AT SPECIFIED SPACING SHOWN ON BASE TRUSS MITEK DESIGN DRAWING.

SCAB CONNECTION PER NOTE D ABOVE

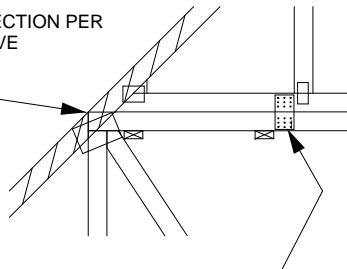

FOR ALL WIND SPEEDS, ATTACH MITEK NP37 20 GA Nail-On PLATES TO EACH FACE OF TRUSSES AT 48" O.C. W/ (4) (0.131" X 1.5") PER MEMBER. STAGGER NAILS FROM OPPOSING FACES ENSURE 0.5" NAIL EDGE DISTANCE.

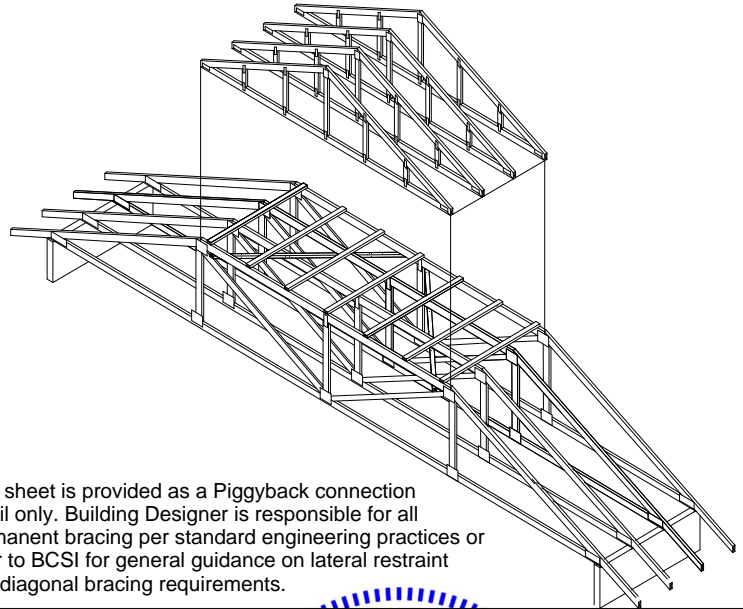

This sheet is provided as a Piggyback connection detail only. Building Designer is responsible for all permanent bracing per standard engineering practices or refer to BCSI for general guidance on lateral restraint and diagonal bracing requirements.

VERTICAL WEB TO EXTEND THROUGH BOTTOM CHORD OF PIGGYBACK

FOR LARGE CONCENTRATED LOADS APPLIED TO CAP TRUSS REQUIRING A VERTICAL WEB:

- 1) VERTICAL WEBS OF PIGGYBACK AND BASE TRUSS MUST MATCH IN SIZE, GRADE, AND MUST LINE UP AS SHOWN IN DETAIL.
- 2) ATTACH 2 x ___ x 4'-0" SCAB TO EACH FACE OF TRUSS ASSEMBLY WITH 2 ROWS OF 10d (0.131" X 3") NAILS SPACED 4" O.C. FROM EACH FACE. (SIZE AND GRADE TO MATCH VERTICAL WEBS OF PIGGYBACK AND BASE TRUSS.) (MINIMUM 2X4)
- 3) THIS CONNECTION IS ONLY VALID FOR A MAXIMUM CONCENTRATED LOAD OF 4000 LBS (@1.15). REVIEW BY A QUALIFIED ENGINEER IS REQUIRED FOR LOADS GREATER THAN 4000 LBS.
- 4) FOR PIGGYBACK TRUSSES CARRYING GIRDER LOADS, NUMBER OF PLYS OF PIGGYBACK TRUSS TO MATCH BASE TRUSS.
- 5) CONCENTRATED LOAD MUST BE APPLIED TO BOTH THE PIGGYBACK AND THE BASE TRUSS DESIGN.

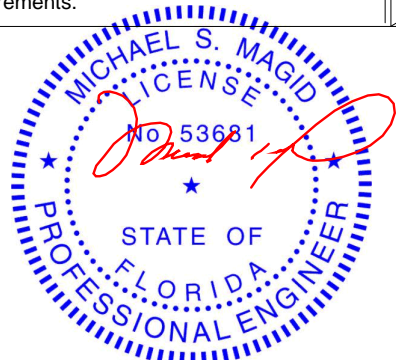
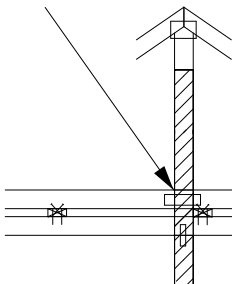

Michael S. Magid PE No.53681
 MiTek USA, Inc. FL Cert 6634
 6904 Parke East Blvd, Tampa FL 33610
 Date:

May 17, 2021

WARNING - Verify design parameters and READ NOTES ON THIS AND INCLUDED MITEK REFERENCE PAGE MII-7473 rev. 5/19/2020 BEFORE USE.

Design valid for use only with MiTek® connectors. This design is based only upon parameters shown, and is for an individual building component, not a truss system. Before use, the building designer must verify the applicability of design parameters and properly incorporate this design into the overall building design. Bracing indicated is to prevent buckling of individual truss web and/or chord members only. Additional temporary and permanent bracing is always required for stability and to prevent collapse with possible personal injury and property damage. For general guidance regarding the fabrication, storage, delivery, erection and bracing of trusses and truss systems, see **ANSI/TPI1 Quality Criteria, DSB-89 and BCSI Building Component**

Safety Information available from Truss Plate Institute, 2670 Crain Highway, Suite 203 Waldorf, MD 20601



6904 Parke East Blvd.
 Tampa, FL 33610

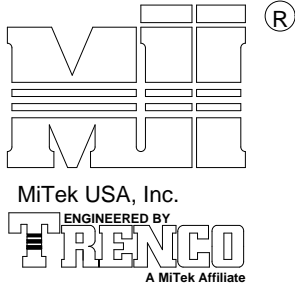

MAXIMUM WIND SPEED = REFER TO NOTES D AND OR E
 MAX MEAN ROOF HEIGHT = 30 FEET
 MAX TRUSS SPACING = 24" O.C.
 CATEGORY II BUILDING
 EXPOSURE B or C
 ENCLOSED BUILDING
 LOADING = 5 PSF TC DL MINIMUM
 ASCE 7-10, ASCE 7-16
 DURATION OF LOAD INCREASE : 1.60

DETAIL IS NOT APPLICABLE FOR TRUSSES TRANSFERRING DRAG LOADS (SHEAR TRUSSES). ADDITIONAL CONSIDERATIONS BY BUILDING ENGINEER/DESIGNER ARE REQUIRED.

- A - PIGGYBACK TRUSS, REFER TO MITEK TRUSS DESIGN DRAWING. SHALL BE CONNECTED TO EACH PURLIN WITH (2) 0(0.131" X 3.5") TOE-NAILED.
- B - BASE TRUSS, REFER TO MITEK TRUSS DESIGN DRAWING.
- C - PURLINS AT EACH BASE TRUSS JOINT AND A MAXIMUM 24" O.C. UNLESS SPECIFIED CLOSER ON MITEK TRUSS DESIGN DRAWING. CONNECT TO BASE TRUSS WITH (2) (0.131" X 3.5") NAILS EACH.
- D - 2 X ___ X 4'-0" SCAB, SIZE TO MATCH TOP CHORD OF PIGGYBACK TRUSS, MIN GRADE #2, ATTACHED TO ONE FACE, CENTERED ON INTERSECTION, WITH (2) ROWS OF (0.131" X 3") NAILS @ 4" O.C. SCAB MAY BE OMITTED PROVIDED THE TOP CHORD SHEATHING IS CONTINUOUS OVER INTERSECTION AT LEAST 1 FT. IN BOTH DIRECTIONS AND:
 1. WIND SPEED OF 115 MPH OR LESS FOR ANY PIGGYBACK SPAN, OR
 2. WIND SPEED OF 116 MPH TO 180 MPH WITH A MAXIMUM PIGGYBACK SPAN OF 12 ft.
- E - FOR WIND SPEED IN THE RANGE 116 MPH - 180 MPH ADD 9' x 9' x 1/2" PLYWOOD (or 7/16" OSB) GUSSET EACH SIDE AT 48" O.C. OR LESS. ATTACH WITH 3 - 6d (0.113" X 2") NAILS INTO EACH CHORD FROM EACH SIDE (TOTAL - 12 NAILS)

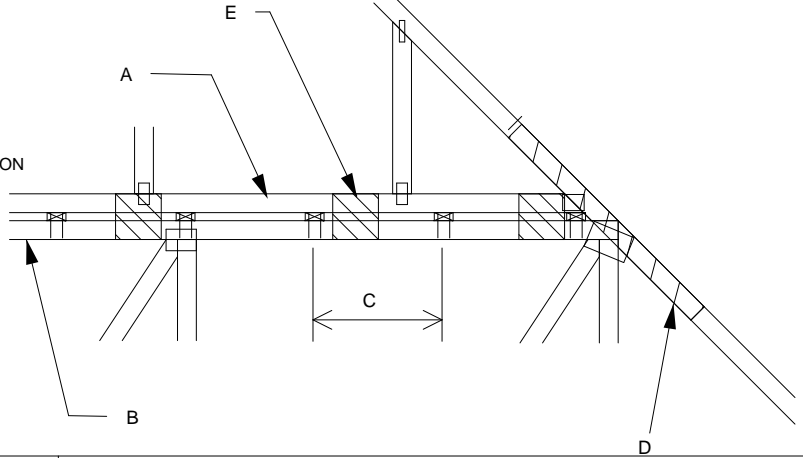

WHEN NO GAP BETWEEN PIGGYBACK AND BASE TRUSS EXISTS:
 REPLACE TOE NAILING OF PIGGYBACK TRUSS TO PURLINS WITH PLYWOOD GUSSETS AS SHOWN, AND INSTALL PURLINS TO BOTTOM EDGE OF BASE TRUSS TOP CHORD AT SPECIFIED SPACING SHOWN ON BASE TRUSS MITEK DESIGN DRAWING.

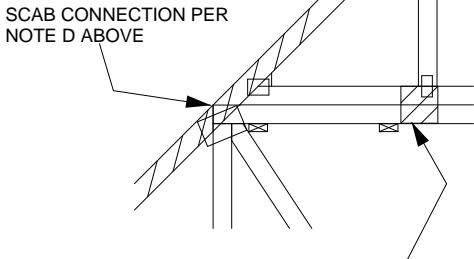

7" x 7" x 1/2" PLYWOOD (or 7/16" OSB) GUSSET EACH SIDE AT 24" O.C. ATTACH WITH 3 - 6d (0.113" X 2") NAILS INTO EACH CHORD FROM EACH SIDE (TOTAL - 12 NAILS)

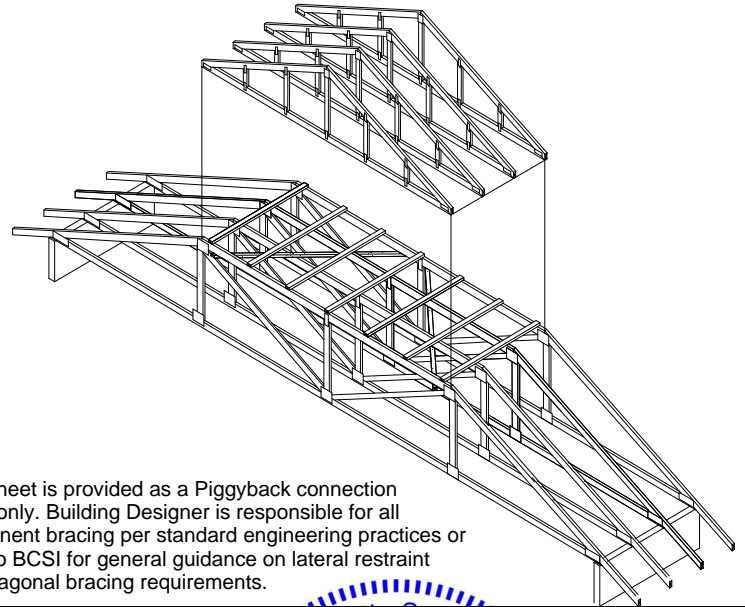

This sheet is provided as a Piggyback connection detail only. Building Designer is responsible for all permanent bracing per standard engineering practices or refer to BCSI for general guidance on lateral restraint and diagonal bracing requirements.

VERTICAL WEB TO EXTEND THROUGH BOTTOM CHORD OF PIGGYBACK

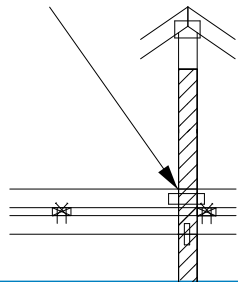

FOR LARGE CONCENTRATED LOADS APPLIED TO CAP TRUSS REQUIRING A VERTICAL WEB:

- 1) VERTICAL WEBS OF PIGGYBACK AND BASE TRUSS MUST MATCH IN SIZE, GRADE, AND MUST LINE UP AS SHOWN IN DETAIL.
- 2) ATTACH 2 x ___ x 4'-0" SCAB TO EACH FACE OF TRUSS ASSEMBLY WITH 2 ROWS OF 10d (0.131" X 3") NAILS SPACED 4" O.C. FROM EACH FACE. (SIZE AND GRADE TO MATCH VERTICAL WEBS OF PIGGYBACK AND BASE TRUSS.) (MINIMUM 2X4)
- 3) THIS CONNECTION IS ONLY VALID FOR A MAXIMUM CONCENTRATED LOAD OF 4000 LBS (@1.15). REVIEW BY A QUALIFIED ENGINEER IS REQUIRED FOR LOADS GREATER THAN 4000 LBS.
- 4) FOR PIGGYBACK TRUSSES CARRYING GIRDER LOADS, NUMBER OF PLYS OF PIGGYBACK TRUSS TO MATCH BASE TRUSS.
- 5) CONCENTRATED LOAD MUST BE APPLIED TO BOTH THE PIGGYBACK AND THE BASE TRUSS DESIGN.

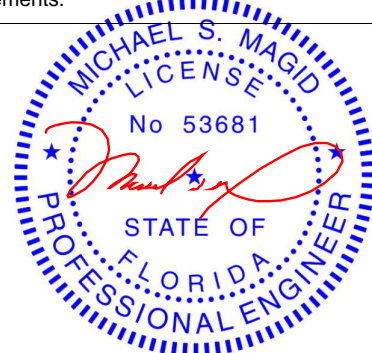

Michael S. Magid PE No.53681
 MiTek USA, Inc. FL Cert 6634
 6904 Parke East Blvd. Tampa FL 33610
 Date:

May 17, 2021

WARNING - Verify design parameters and READ NOTES ON THIS AND INCLUDED MITEK REFERENCE PAGE MII-7473 rev. 5/19/2020 BEFORE USE.

Design valid for use only with MiTek® connectors. This design is based only upon parameters shown, and is for an individual building component, not a truss system. Before use, the building designer must verify the applicability of design parameters and properly incorporate this design into the overall building design. Bracing indicated is to prevent buckling of individual truss web and/or chord members only. Additional temporary and permanent bracing is always required for stability and to prevent collapse with possible personal injury and property damage. For general guidance regarding the fabrication, storage, delivery, erection and bracing of trusses and truss systems, see **ANSI/TP1 Quality Criteria, DSB-89 and BCSI Building Component**

Safety Information available from Truss Plate Institute, 2670 Crain Highway, Suite 203 Waldorf, MD 20601



6904 Parke East Blvd.
 Tampa, FL 33610

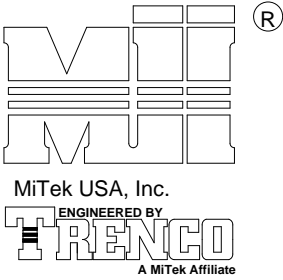

TOTAL NUMBER OF NAILS EACH SIDE OF BREAK *		X INCHES	MAXIMUM FORCE (lbs) 15% LOAD DURATION							
			SP		DF		SPF		HF	
2x4	2x6		2x4	2x6	2x4	2x6	2x4	2x6	2x4	2x6
20	30	24"	1706	2559	1561	2342	1320	1980	1352	2028
26	39	30"	2194	3291	2007	3011	1697	2546	1738	2608
32	48	36"	2681	4022	2454	3681	2074	3111	2125	3187
38	57	42"	3169	4754	2900	4350	2451	3677	2511	3767
44	66	48"	3657	5485	3346	5019	2829	4243	2898	4347

* DIVIDE EQUALLY FRONT AND BACK

ATTACH 2x_ SCAB OF THE SAME SIZE AND GRADE AS THE BROKEN MEMBER TO EACH FACE OF THE TRUSS (CENTER ON BREAK OR SPLICE) WITH 10d (0.131" X 3") NAILS (TWO ROWS FOR 2x4, THREE ROWS FOR 2x6) SPACED 4" O.C. AS SHOWN. STAGGER NAIL SPACING FROM FRONT FACE AND BACK FACE FOR A NET 0-2-0 O.C. SPACING IN THE MAIN MEMBER. USE A MIN. 0-3-0 MEMBER END DISTANCE.

THE LENGTH OF THE BREAK (C) SHALL NOT EXCEED 12". (C=PLATE LENGTH FOR SPLICE REPAIRS)
 THE MINIMUM OVERALL SCAB LENGTH REQUIRED (L) IS CALCULATED AS FOLLOWS:
 $L = (2) X + C$

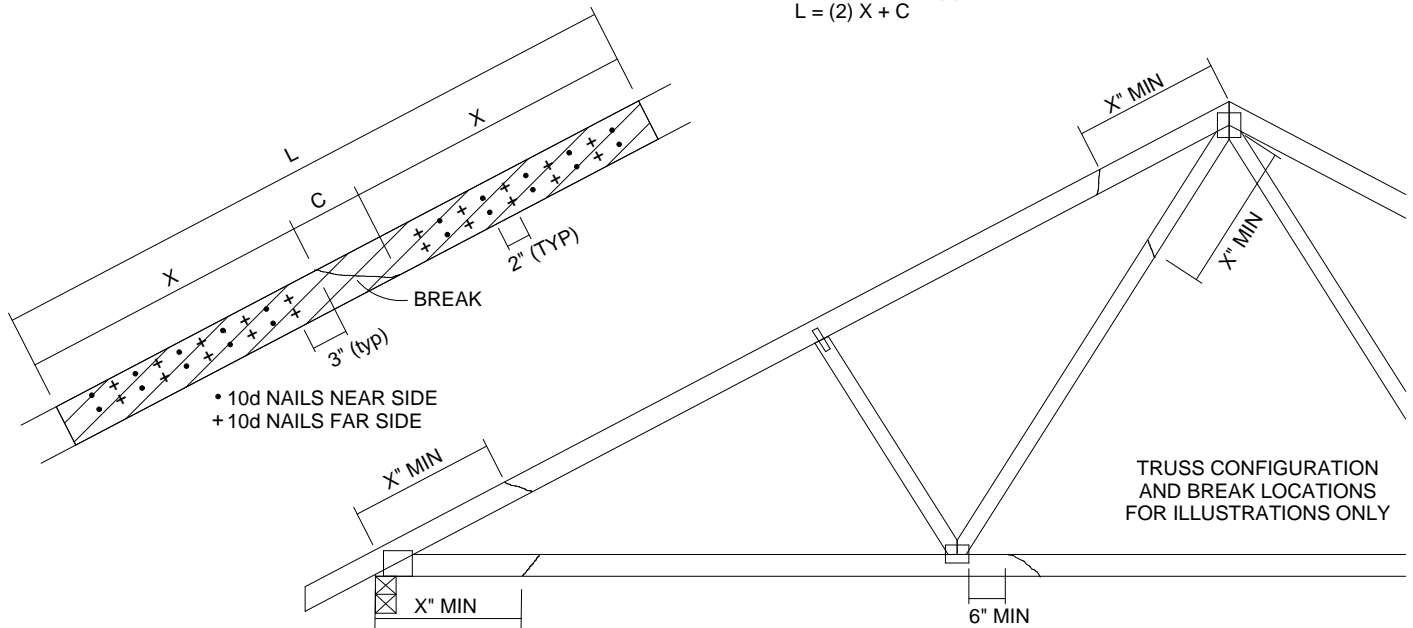

THE LOCATION OF THE BREAK MUST BE GREATER THAN OR EQUAL TO THE REQUIRED X DIMENSION FROM ANY PERIMETER BREAK OR HEEL JOINT AND A MINIMUM OF 6" FROM ANY INTERIOR JOINT (SEE SKETCH ABOVE)

DO NOT USE REPAIR FOR JOINT SPLICES

NOTES:

1. THIS REPAIR DETAIL IS TO BE USED ONLY FOR THE APPLICATION SHOWN. THIS REPAIR DOES NOT IMPLY THAT THE REMAINING PORTION OF THE TRUSS IS UNDAMAGED. THE ENTIRE TRUSS SHALL BE INSPECTED TO VERIFY THAT NO FURTHER REPAIRS ARE REQUIRED. WHEN THE REQUIRED REPAIRS ARE PROPERLY APPLIED, THE TRUSS WILL BE CAPABLE OF SUPPORTING THE LOADS INDICATED.
2. ALL MEMBERS MUST BE RETURNED TO THEIR ORIGINAL POSITIONS BEFORE APPLING REPAIR AND HELD IN PLACE DURING APPLICATION OF REPAIR.
3. THE END DISTANCE, EDGE DISTANCE AND SPACING OF NAILS SHALL BE SUCH AS TO AVOID UNUSUAL SPLITTING OF THE WOOD.
4. WHEN NAILING THE SCABS, THE USE OF A BACKUP WEIGHT IS RECOMMENDED TO AVOID LOOSENING OF THE CONNECTOR PLATES AT THE JOINTS OR SPLICES.
5. THIS REPAIR IS TO BE USED FOR SINGLE PLY TRUSSES IN THE 2x_ ORIENTATION ONLY.
6. THIS REPAIR IS LIMITED TO TRUSSES WITH NO MORE THAN THREE BROKEN MEMBERS.

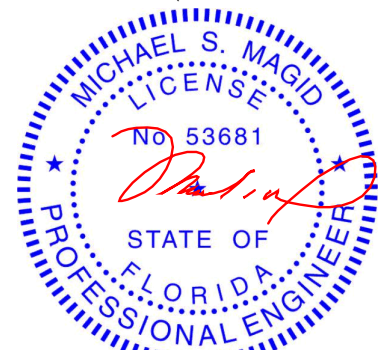

Michael S. Magid PE No.53681
 MiTek USA, Inc. FL Cert 6634
 6904 Parke East Blvd Tampa, FL 33610
 Date:

May 17, 2021

WARNING - Verify design parameters and READ NOTES ON THIS AND INCLUDED MITEK REFERENCE PAGE MII-7473 rev. 5/19/2020 BEFORE USE.

Design valid for use only with MiTek® connectors. This design is based only upon parameters shown, and is for an individual building component, not a truss system. Before use, the building designer must verify the applicability of design parameters and properly incorporate this design into the overall building design. Bracing indicated is to prevent buckling of individual truss web and/or chord members only. Additional temporary and permanent bracing is always required for stability and to prevent collapse with possible personal injury and property damage. For general guidance regarding the fabrication, storage, delivery, erection and bracing of trusses and truss systems, see

ANSI/TPI1 Quality Criteria, DSB-89 and BCSI Building Component

Safety Information available from Truss Plate Institute, 2670 Crain Highway, Suite 203 Waldorf, MD 20601



6904 Parke East Blvd.
 Tampa, FL 33610

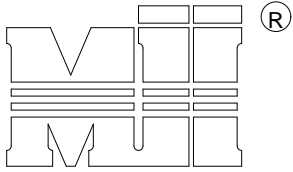

NOTES:

- TOE-NAILS SHALL BE DRIVEN AT AN ANGLE OF 45 DEGREES WITH THE MEMBER AND MUST HAVE FULL WOOD SUPPORT. (NAIL MUST BE DRIVEN THROUGH AND EXIT AT THE BACK CORNER OF THE MEMBER END AS SHOWN).
- THE END DISTANCE, EDGE DISTANCE, AND SPACING OF NAILS SHALL BE SUCH AS TO AVOID UNUSUAL SPLITTING OF THE WOOD.
- ALLOWABLE VALUE SHALL BE THE LESSER VALUE OF THE TWO SPECIES FOR MEMBERS OF DIFFERENT SPECIES.

MiTek USA, Inc.
ENGINEERED BY
TRENCO
A MiTek Affiliate

THIS DETAIL APPLICABLE TO THE THREE END DETAILS SHOWN BELOW

VIEWS SHOWN ARE FOR ILLUSTRATION PURPOSES ONLY

TOE-NAIL SINGLE SHEAR VALUES PER NDS 2018 (lb/nail)

	DIAM.	SP	DF	HF	SPF	SPF-S
3.5" LONG	.131	88.0	80.6	69.9	68.4	59.7
	.135	93.5	85.6	74.2	72.6	63.4
	.162	108.8	99.6	86.4	84.5	73.8
3.25" LONG	.128	74.2	67.9	58.9	57.6	50.3
	.131	75.9	69.5	60.3	59.0	51.1
	.148	81.4	74.5	64.6	63.2	52.5

VALUES SHOWN ARE CAPACITY PER TOE-NAIL.
APPLICABLE DURATION OF LOAD INCREASES MAY BE APPLIED.

EXAMPLE:

(3) - 16d (0.162" X 3.5") NAILS WITH SPF SPECIES BOTTOM CHORD

For load duration increase of 1.15:

3 (nails) X 84.5 (lb/nail) X 1.15 (DOL) = 291.5 lb Maximum Capacity

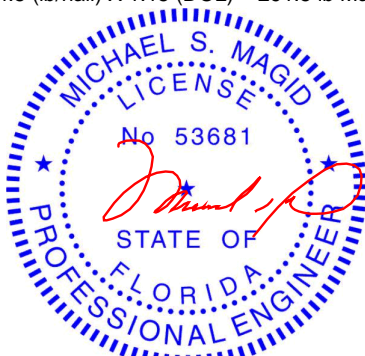
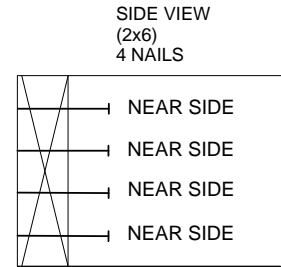
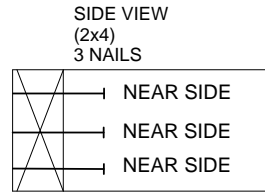
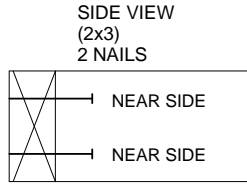

May 17, 2021

Michael S. Magid PE No.53681
MiTek USA, Inc. FL Cert 6634
6904 Parke East Blvd. Tampa FL 33610
Date:

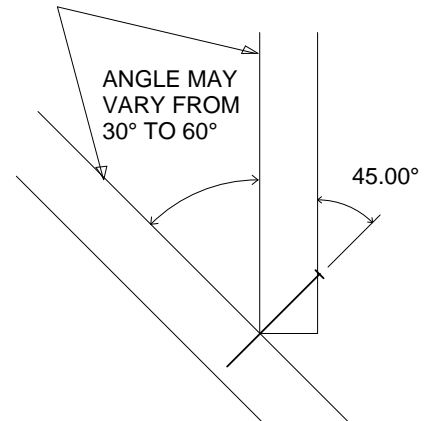
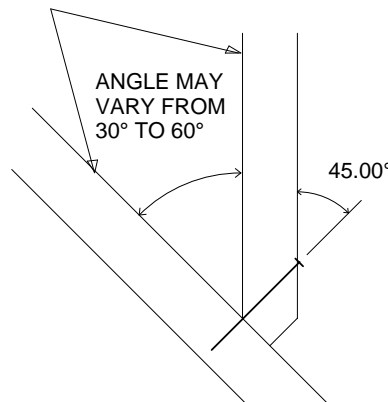
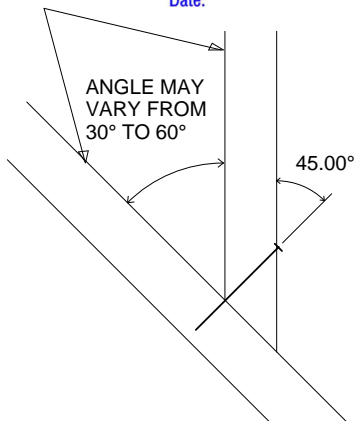

WARNING - Verify design parameters and READ NOTES ON THIS AND INCLUDED MITEK REFERENCE PAGE MII-7473 rev. 5/19/2020 BEFORE USE.

Design valid for use only with MiTek® connectors. This design is based only upon parameters shown, and is for an individual building component, not a truss system. Before use, the building designer must verify the applicability of design parameters and properly incorporate this design into the overall building design. Bracing indicated is to prevent buckling of individual truss web and/or chord members only. Additional temporary and permanent bracing is always required for stability and to prevent collapse with possible personal injury and property damage. For general guidance regarding the fabrication, storage, delivery, erection and bracing of trusses and truss systems, see **ANSI/TPI1 Quality Criteria, DSB-89 and BCSI Building Component Safety Information** available from Truss Plate Institute, 2670 Crain Highway, Suite 203 Waldorf, MD 20601



6904 Parke East Blvd.
Tampa, FL 36610

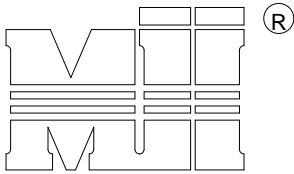

MiTek USA, Inc.



MiTek USA, Inc.

GENERAL SPECIFICATIONS

1. NAIL SIZE 10d (0.131" X 3")
2. WOOD SCREW = 3" WS3 USP OR EQUIVALENT
DO NOT USE DRYWALL OR DECKING TYPE SCREW
3. INSTALL VALLEY TRUSSES (24" O.C. MAXIMUM) AND SECURE PER DETAIL A
4. BRACE VALLEY WEBS IN ACCORDANCE WITH THE INDIVIDUAL DESIGN DRAWINGS.
5. BASE TRUSS SHALL BE DESIGNED WITH A PURLIN SPACING EQUIVALENT TO THE RAKE DIMENSION OF THE VALLEY TRUSS SPACING.
6. NAILING DONE PER NDS - 01
7. VALLEY STUD SPACING NOT TO EXCEED 48" O.C.

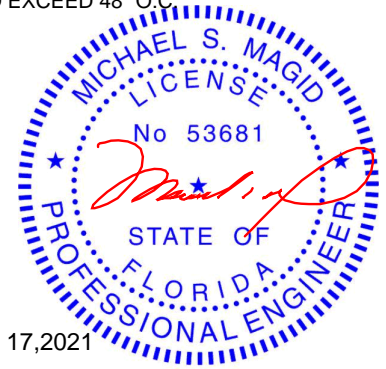
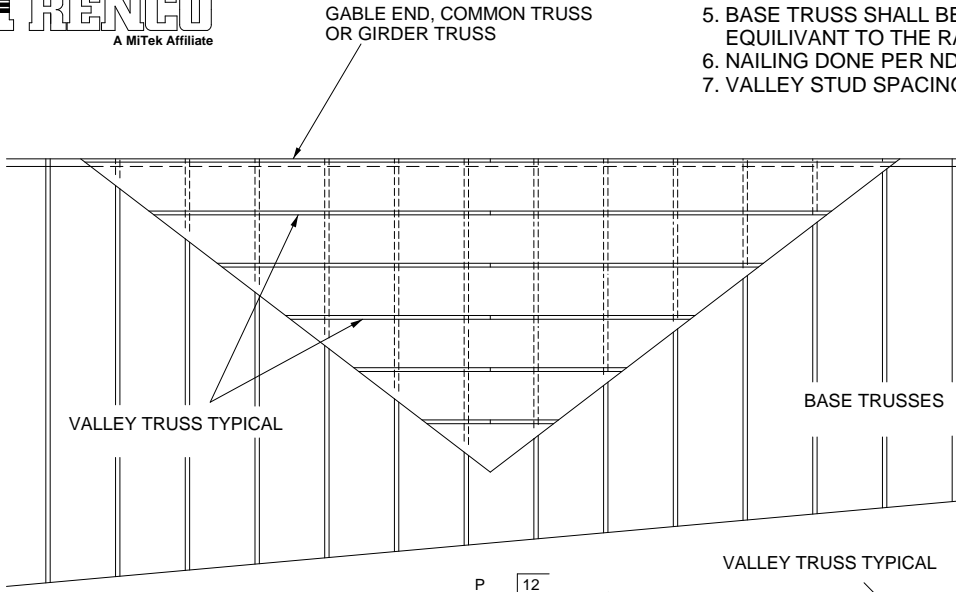

Michael S. Magid PE No.53681
MiTek USA, Inc. FL Cert 6634
6904 Parke East Blvd. Tampa FL 33610
Date:

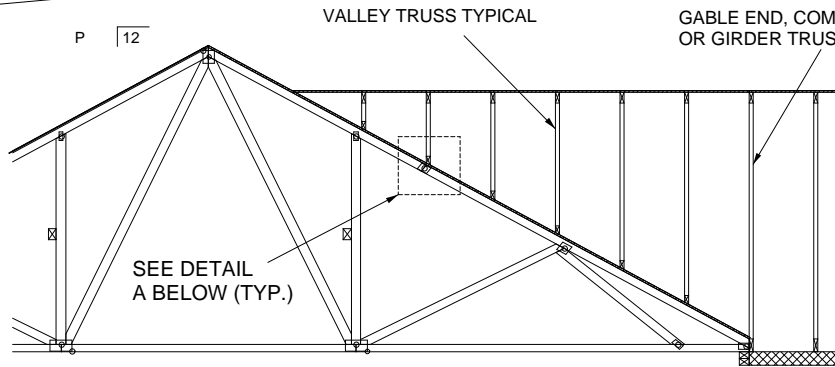

SECURE VALLEY TRUSS
W/ ONE ROW OF 10d
NAILS 6" O.C.

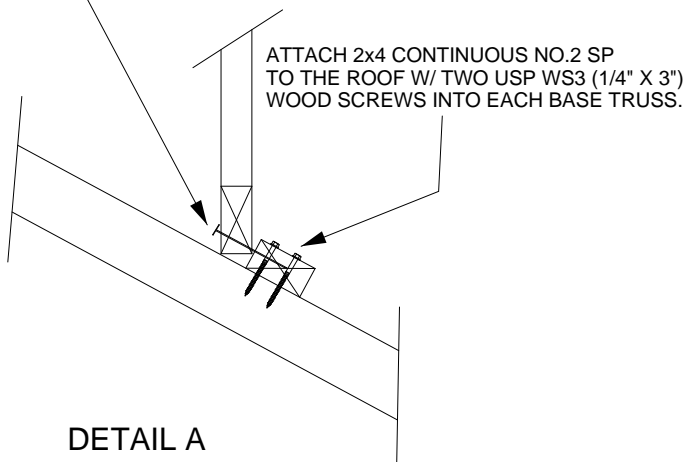

ATTACH 2x4 CONTINUOUS NO.2 SP
TO THE ROOF W/ TWO USP WS3 (1/4" X 3")
WOOD SCREWS INTO EACH BASE TRUSS.

DETAIL A
(NO SHEATHING)
N.T.S.

WIND DESIGN PER ASCE 7-98, ASCE 7-02, ASCE 7-05 146 MPH
WIND DESIGN PER ASCE 7-10, ASCE 7-16 160 MPH
MAX MEAN ROOF HEIGHT = 30 FEET
ROOF PITCH = MINIMUM 3/12 MAXIMUM 6/12
CATEGORY II BUILDING
EXPOSURE C
WIND DURATION OF LOAD INCREASE : 1.60
MAX TOP CHORD TOTAL LOAD = 50 PSF
MAX SPACING = 24" O.C. (BASE AND VALLEY)
MINIMUM REDUCED DEAD LOAD OF 6 PSF
ON THE TRUSSES

WARNING - Verify design parameters and READ NOTES ON THIS AND INCLUDED MITEK REFERENCE PAGE MII-7473 rev. 5/19/2020 BEFORE USE.

Design valid for use only with MiTek® connectors. This design is based only upon parameters shown, and is for an individual building component, not a truss system. Before use, the building designer must verify the applicability of design parameters and properly incorporate this design into the overall building design. Bracing indicated is to prevent buckling of individual truss web and/or chord members only. Additional temporary and permanent bracing is always required for stability and to prevent collapse with possible personal injury and property damage. For general guidance regarding the fabrication, storage, delivery, erection and bracing of trusses and truss systems, see

ANSI/TPI1 Quality Criteria, DSB-89 and BCSI Building Component

Safety Information available from Truss Plate Institute, 2670 Crain Highway, Suite 203 Waldorf, MD 20601



6904 Parke East Blvd.
Tampa, FL 36610

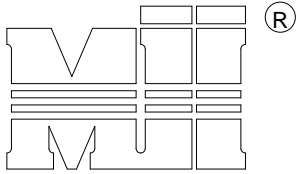

MiTek USA, Inc.
ENGINEERED BY
TRENCO
A MiTek Affiliate

MiTek USA, Inc.

GENERAL SPECIFICATIONS

1. NAIL SIZE 10d (0.131" X 3")
2. WOOD SCREW = 4.5" WS45 USP OR EQUIVANT
3. INSTALL SHEATHING TO TOP CHORD OF BASE TRUSSES.
4. INSTALL VALLEY TRUSSES (24" O.C. MAXIMUM) AND SECURE TO BASE TRUSSES AS PER DETAIL A
5. BRACE VALLEY WEBS IN ACCORDANCE WITH THE INDIVIDUAL DESIGN DRAWINGS.
6. NAILING DONE PER NDS-01
7. VALLEY STUD SPACING NOT TO EXCEED 48" O.C.

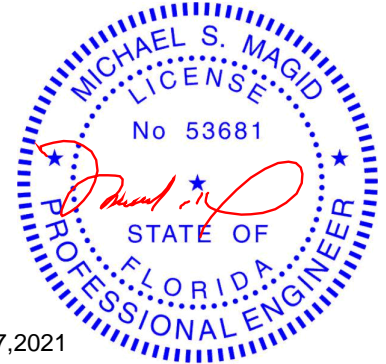
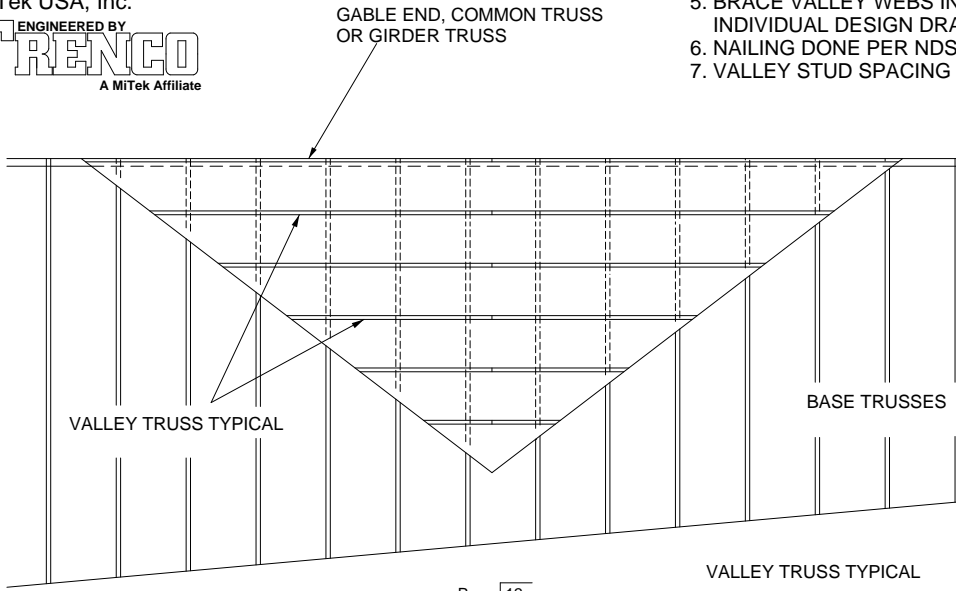

May 17, 2021

Michael S. Magid PE No.53681
MiTek USA, Inc. FL Cert 6634
6904 Parke East Blvd. Tampa FL 33610
Date:

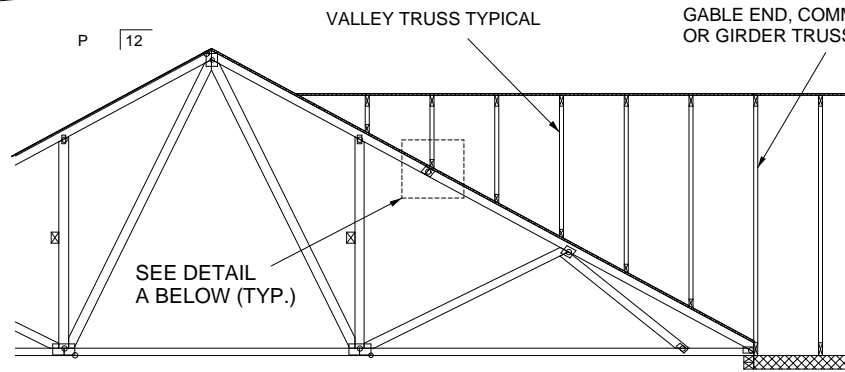

SECURE VALLEY TRUSS
W/ ONE ROW OF 10d
NAILS 6" O.C.

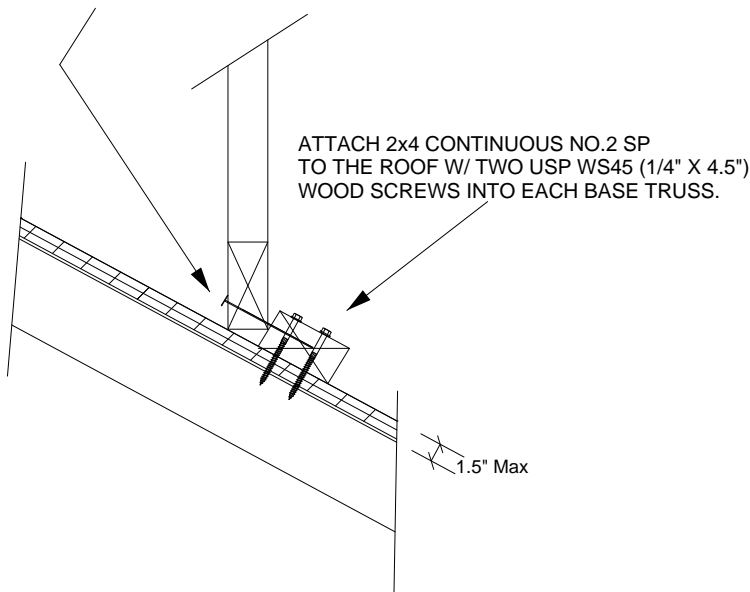

WIND DESIGN PER ASCE 7-98, ASCE 7-02, ASCE 7-05 146 MPH
WIND DESIGN PER ASCE 7-10, ASCE 7-16 160 MPH
MAX MEAN ROOF HEIGHT = 30 FEET
ROOF PITCH = MINIMUM 3/12 MAXIMUM 6/12
CATEGORY II BUILDING
EXPOSURE C
WIND DURATION OF LOAD INCREASE : 1.60
MAX TOP CHORD TOTAL LOAD = 50 PSF
MAX SPACING = 24" O.C. (BASE AND VALLEY)
MINIMUM REDUCED DEAD LOAD OF 6 PSF
ON THE TRUSSES

WARNING - Verify design parameters and READ NOTES ON THIS AND INCLUDED MITEK REFERENCE PAGE MII-7473 rev. 5/19/2020 BEFORE USE.

Design valid for use only with MiTek® connectors. This design is based only upon parameters shown, and is for an individual building component, not a truss system. Before use, the building designer must verify the applicability of design parameters and properly incorporate this design into the overall building design. Bracing indicated is to prevent buckling of individual truss web and/or chord members only. Additional temporary and permanent bracing is always required for stability and to prevent collapse with possible personal injury and property damage. For general guidance regarding the fabrication, storage, delivery, erection and bracing of trusses and truss systems, see

ANSI/TPI1 Quality Criteria, DSB-89 and BCSI Building Component

Safety Information available from Truss Plate Institute, 2670 Crain Highway, Suite 203 Waldorf, MD 20601



6904 Parke East Blvd.
Tampa, FL 36610

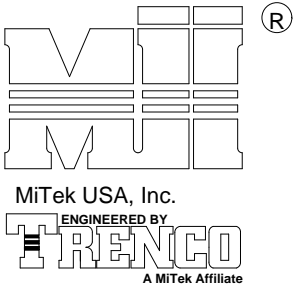

GENERAL SPECIFICATIONS

1. NAIL SIZE 16d (0.131" X 3.5")
2. INSTALL VALLEY TRUSSES (24" O.C. MAXIMUM) AND SECURE PER DETAIL A
3. BRACE VALLEY WEBS IN ACCORDANCE WITH THE INDIVIDUAL DESIGN DRAWINGS.
4. BASE TRUSS SHALL BE DESIGNED WITH A PURLIN SPACING EQUIVARIANT TO THE RAKE DIMENSION OF THE VALLEY TRUSS SPACING.
5. NAILING DONE PER NDS - 01
6. VALLEY STUD SPACING NOT TO EXCEED 48" O.C.
7. ALL LUMBER SPECIES TO BE SP.

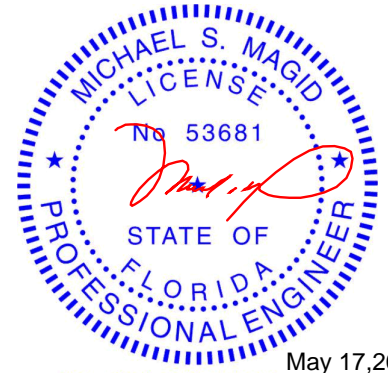
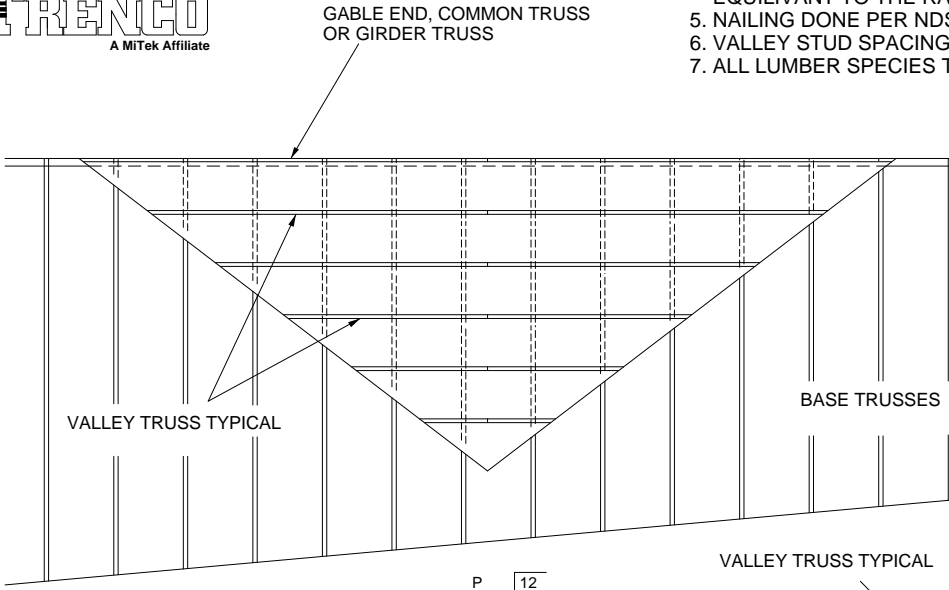

May 17, 2021

Michael S. Magid PE No. 53681
MiTek USA, Inc. FL Cert 6634
6904 Parke East Blvd. Tampa FL 33610
Date:

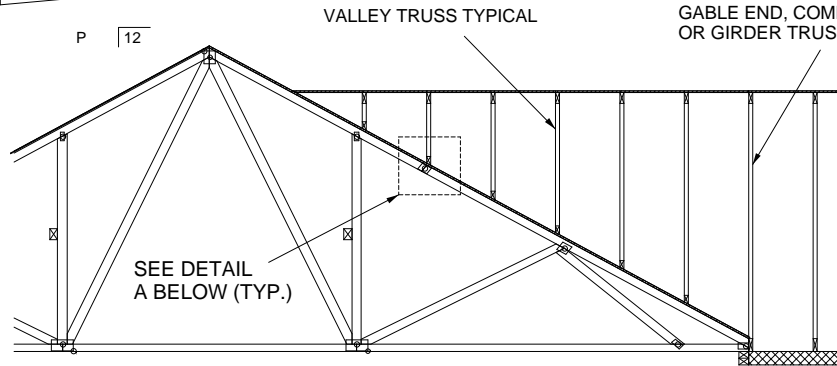

SECURE VALLEY TRUSS
W/ ONE ROW OF 16d
NAILS 6" O.C.

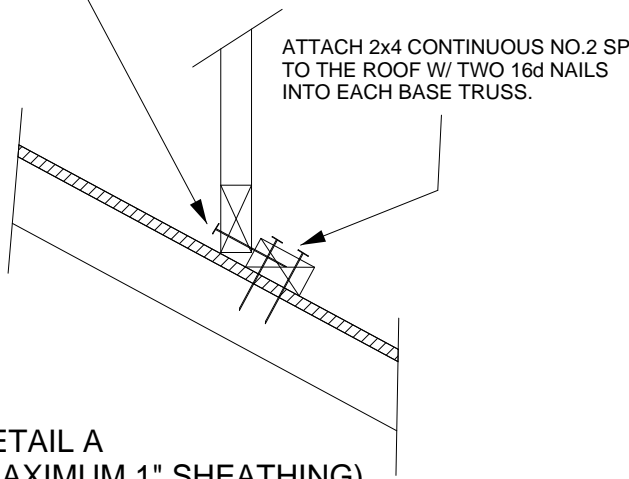

ATTACH 2x4 CONTINUOUS NO.2 SP
TO THE ROOF W/ TWO 16d NAILS
INTO EACH BASE TRUSS.

DETAIL A
(MAXIMUM 1" SHEATHING)
N.T.S.

WIND DESIGN PER ASCE 7-98, ASCE 7-02, ASCE 7-05 120 MPH
WIND DESIGN PER ASCE 7-10, ASCE 7-16 150 MPH
MAX MEAN ROOF HEIGHT = 30 FEET
ROOF PITCH = MINIMUM 3/12 MAXIMUM 10/12
CATEGORY II BUILDING
EXPOSURE C OR B
WIND DURATION OF LOAD INCREASE : 1.60
MAX TOP CHORD TOTAL LOAD = 60 PSF
MAX SPACING = 24" O.C. (BASE AND VALLEY)
MINIMUM REDUCED DEAD LOAD OF 4.2 PSF
ON THE TRUSSES

WARNING - Verify design parameters and READ NOTES ON THIS AND INCLUDED MITEK REFERENCE PAGE MII-7473 rev. 5/19/2020 BEFORE USE.

Design valid for use only with MiTek® connectors. This design is based only upon parameters shown, and is for an individual building component, not a truss system. Before use, the building designer must verify the applicability of design parameters and properly incorporate this design into the overall building design. Bracing indicated is to prevent buckling of individual truss web and/or chord members only. Additional temporary and permanent bracing is always required for stability and to prevent collapse with possible personal injury and property damage. For general guidance regarding the fabrication, storage, delivery, erection and bracing of trusses and truss systems, see

ANSI/TPI1 Quality Criteria, DSB-89 and BCSI Building Component

Safety Information available from Truss Plate Institute, 2670 Crain Highway, Suite 203 Waldorf, MD 20601



6904 Parke East Blvd.
Tampa, FL 36610

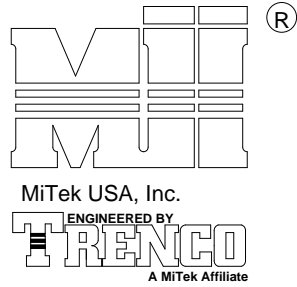

NOTE: VALLEY STUD SPACING NOT TO EXCEED 48" O.C. SPACING

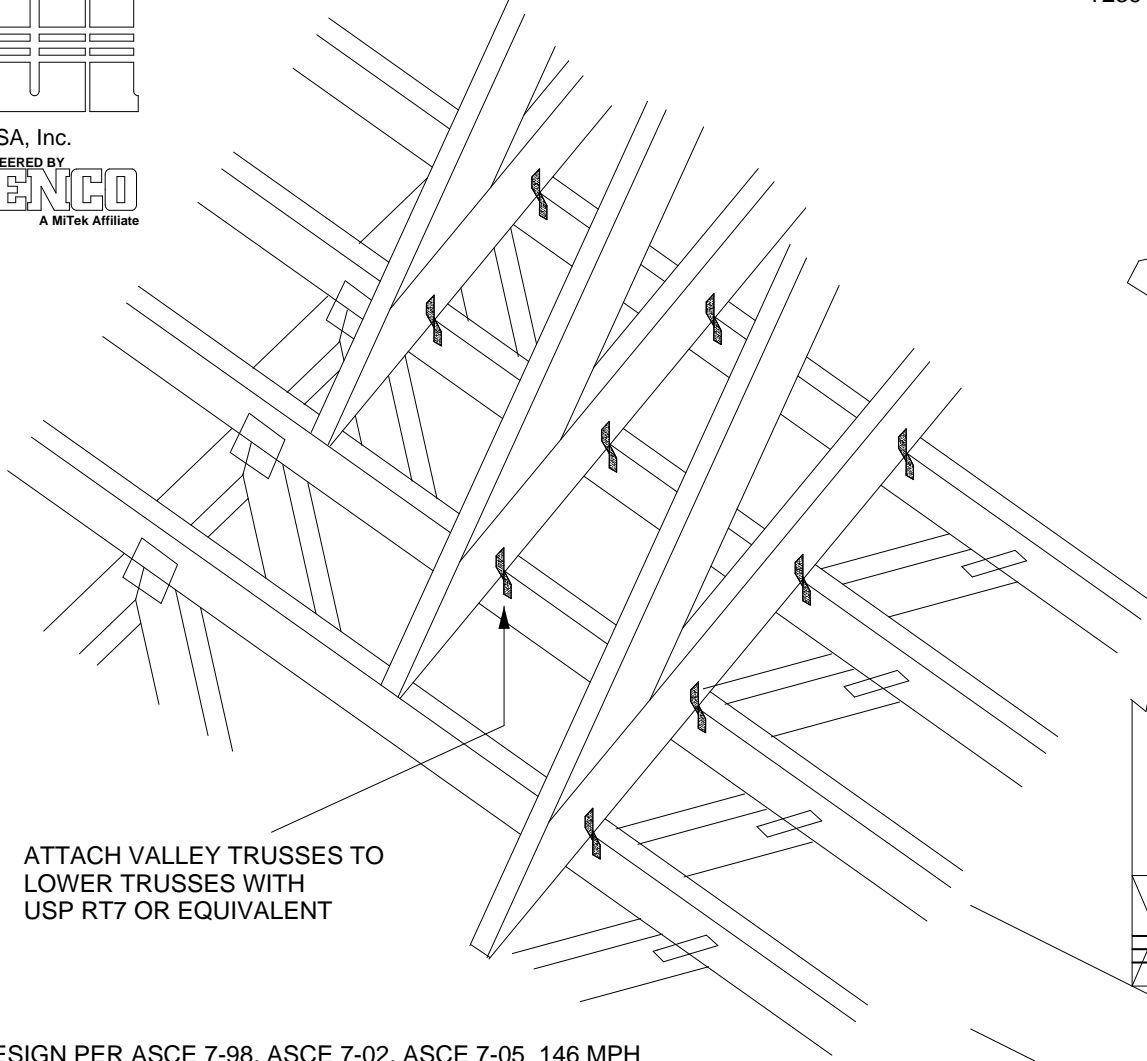

ATTACH VALLEY TRUSSES TO LOWER TRUSSES WITH USP RT7 OR EQUIVALENT

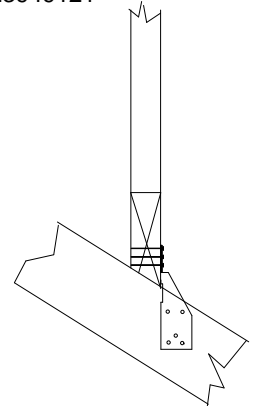

FOR BEVELED BOTTOM CHORD, CLIP MAY BE APPLIED TO EITHER FACE

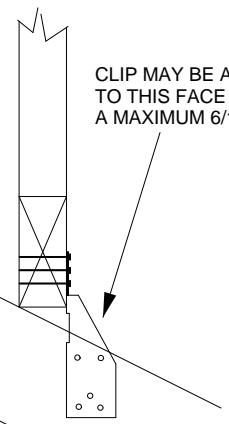

CLIP MAY BE APPLIED TO THIS FACE UP TO A MAXIMUM 6/12 PITCH

NON-BEVELED BOTTOM CHORD

NON-BEVELED BOTTOM CHORD

WIND DESIGN PER ASCE 7-98, ASCE 7-02, ASCE 7-05 146 MPH
WIND DESIGN PER ASCE 7-10, ASCE 7-16 160 MPH
MAX MEAN ROOF HEIGHT = 30 FEET
CATEGORY II BUILDING
EXPOSURE B or C
WIND DURATION OF LOAD INCREASE : 1.6
MAX TOP CHORD TOTAL LOAD = 50 PSF
MAX SPACING = 24" O.C. (BASE AND VALLEY)

SUPPORTING TRUSSES DIRECTLY UNDER VALLEY TRUSSES MUST BE DESIGNED WITH A MAXIMUM UNBRACED LENGTH OF 2'-10" ON AFFECTED TOP CHORDS.

NOTES:
- SHEATHING APPLIED AFTER INSTALLATION OF VALLEY TRUSSES
- THIS DETAIL IS NOT APPLICABLE FOR SPF-S SPECIES LUMBER.

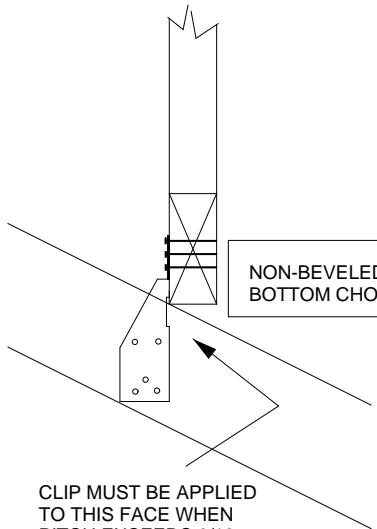

CLIP MUST BE APPLIED TO THIS FACE WHEN PITCH EXCEEDS 6/12. (MAXIMUM 12/12 PITCH)

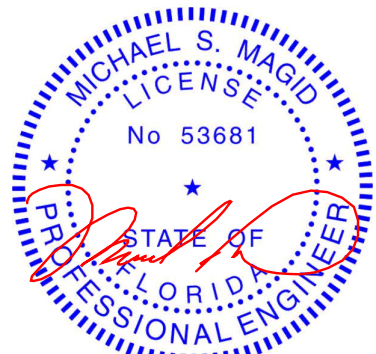

Michael S. Magid PE No.53681
MiTek USA, Inc. FL Cert 6634
6904 Parke East Blvd. Tampa FL 33610
Date:

May 17,2021

WARNING - Verify design parameters and READ NOTES ON THIS AND INCLUDED MITEK REFERENCE PAGE MII-7473 rev. 5/19/2020 BEFORE USE.

Design valid for use only with MiTek® connectors. This design is based only upon parameters shown, and is for an individual building component, not a truss system. Before use, the building designer must verify the applicability of design parameters and properly incorporate this design into the overall building design. Bracing indicated is to prevent buckling of individual truss web and/or chord members only. Additional temporary and permanent bracing is always required for stability and to prevent collapse with possible personal injury and property damage. For general guidance regarding the fabrication, storage, delivery, erection and bracing of trusses and truss systems, see **ANSI/TPI1 Quality Criteria, DSB-89 and BCSI Building Component**

Safety Information available from Truss Plate Institute, 2670 Crain Highway, Suite 203 Waldorf, MD 20601



6904 Parke East Blvd.
Tampa, FL 36610

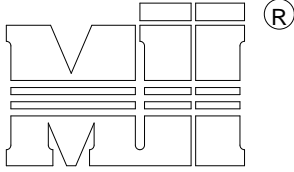

MiTek USA, Inc.
 ENGINEERED BY
TRENCO
 A MiTek Affiliate

TRUSS CRITERIA:

- LOADING: 40-10-0-10
- DURATION FACTOR: 1.15
- SPACING: 24" O.C.
- TOP CHORD: 2x4 OR 2x6
- PITCH: 4/12 - 12/12
- HEEL HEIGHT: STANDARD HEEL UP TO 12" ENERGY HEEL
- END BEARING CONDITION

NOTES:

1. ATTACH 2x_ SCAB (MINIMUM NO.2 GRADE SPF, HF, SP, DF) TO ONE FACE OF TRUSS WITH TWO ROWS OF 10d (0.131" X 3") SPACED 6" O.C.
2. THE END DISTANCE, EDGE DISTANCE, AND SPACING OF NAILS SHALL BE SUCH AS TO AVOID UNUSUAL SPLITTING OF THE WOOD.
3. WHEN NAILING THE SCABS, THE USE OF A BACKUP WEIGHT IS RECOMMENDED TO AVOID LOOSENING OF THE CONNECTOR PLATES AT THE JOINTS OR SPLICES.

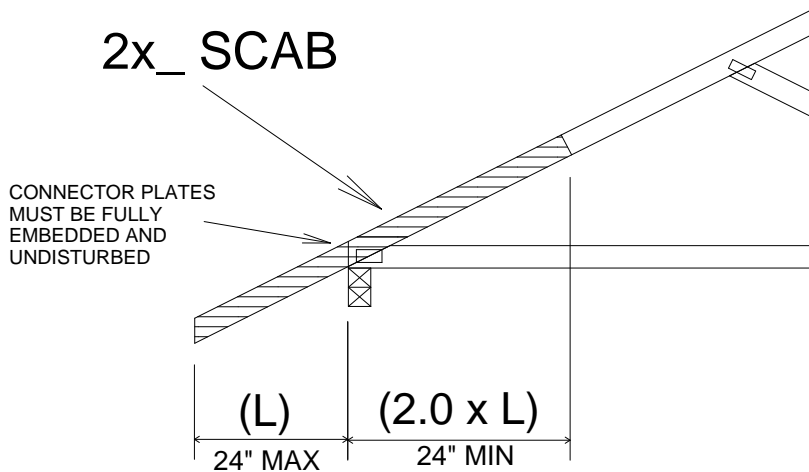

IMPORTANT

This detail to be used only with trusses (spans less than 40') spaced 24" o.c. maximum and having pitches between 4/12 and 12/12 and total top chord loads not exceeding 50 psf. Trusses not fitting these criteria should be examined individually.

REFER TO INDIVIDUAL TRUSS DESIGN FOR PLATE SIZES AND LUMBER GRADES

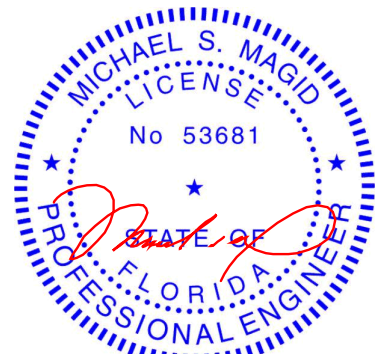

Michael S. Magid PE No.53681
 MiTek USA, Inc. FL Cert 6634
 6904 Parke East Blvd. Tampa FL 33610
 Date:

May 17,2021

WARNING - Verify design parameters and READ NOTES ON THIS AND INCLUDED MITEK REFERENCE PAGE MII-7473 rev. 5/19/2020 BEFORE USE.
 Design valid for use only with MiTek® connectors. This design is based only upon parameters shown, and is for an individual building component, not a truss system. Before use, the building designer must verify the applicability of design parameters and properly incorporate this design into the overall building design. Bracing indicated is to prevent buckling of individual truss web and/or chord members only. Additional temporary and permanent bracing is always required for stability and to prevent collapse with possible personal injury and property damage. For general guidance regarding the fabrication, storage, delivery, erection and bracing of trusses and truss systems, see **ANSI/TPI1 Quality Criteria, DSB-89 and BCSI Building Component Safety Information** available from Truss Plate Institute, 2670 Crain Highway, Suite 203 Waldorf, MD 20601



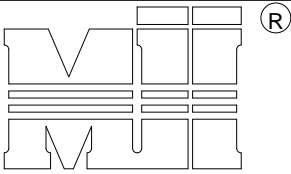

TO MINIMIZE VIBRATION COMMON TO ALL SHALLOW FRAMING SYSTEMS, 2x6 "STRONGBACK" IS RECOMMENDED, LOCATED EVERY 8 TO 10 FEET ALONG A FLOOR TRUSS.

NOTE 1: 2X6 STRONGBACK ORIENTED VERTICALLY MAY BE POSITIONED DIRECTLY UNDER THE TOP CHORD OR DIRECTLY ABOVE THE BOTTOM CHORD. SECURELY FASTENED TO THE TRUSS USING ANY OF THE METHODS ILLUSTRATED BELOW.

NOTE 2: STRONGBACK BRACING ALSO SATISFIES THE LATERAL BRACING REQUIREMENTS FOR THE BOTTOM CHORD OF THE TRUSS WHEN IT IS PLACED ON TOP OF THE BOTTOM CHORD, IS CONTINUOUS FROM END TO END, CONNECTED WITH A METHOD OTHER THAN METAL FRAMING ANCHOR, AND PROPERLY CONNECTED, BY OTHERS, AT THE ENDS.

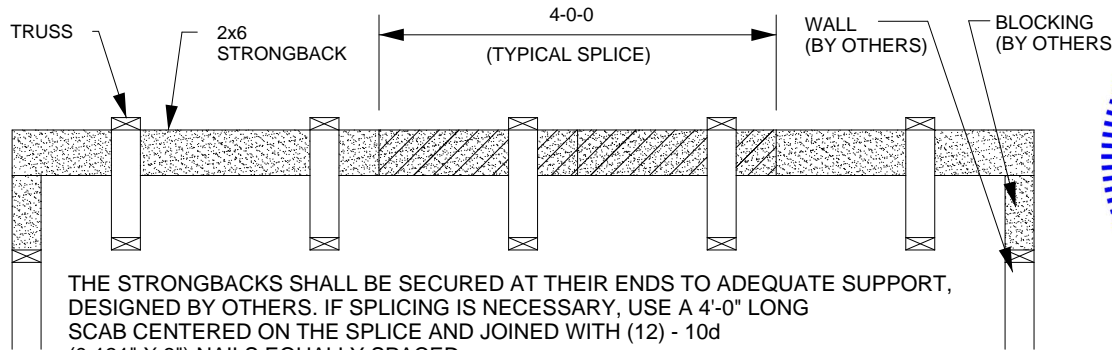
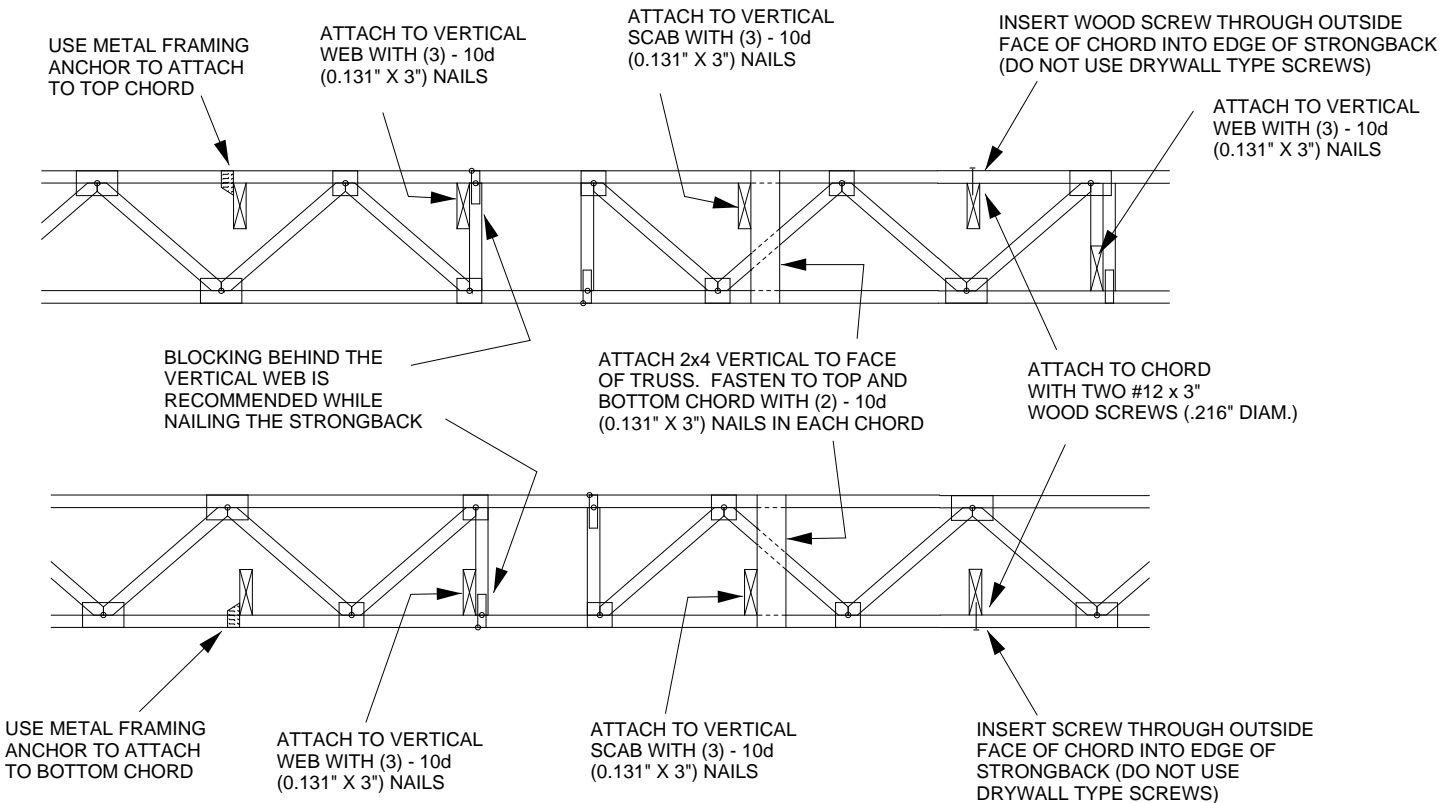

THE STRONGBACKS SHALL BE SECURED AT THEIR ENDS TO ADEQUATE SUPPORT, DESIGNED BY OTHERS. IF SPLICING IS NECESSARY, USE A 4'-0" LONG SCAB CENTERED ON THE SPLICE AND JOINED WITH (12) - 10d (0.131" X 3") NAILS EQUALLY SPACED.

ALTERNATE METHOD OF SPLICING:
OVERLAP STRONGBACK MEMBERS A MINIMUM OF 4'-0" AND FASTEN WITH (12) - 10d (0.131" X 3") NAILS STAGGERED AND EQUALLY SPACED.
(TO BE USED ONLY WHEN STRONGBACK IS NOT ALIGNED WITH A VERTICAL)

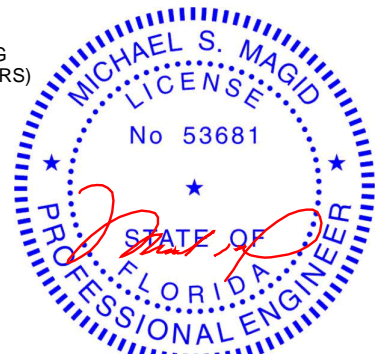

Michael S. Magid PE No.53681
MiTek USA, Inc. FL Cert 6634
6904 Parke East Blvd. Tampa FL 33610
Date:

May 17, 2021

WARNING - Verify design parameters and READ NOTES ON THIS AND INCLUDED MITEK REFERENCE PAGE MII-7473 rev. 5/19/2020 BEFORE USE.

Design valid for use only with MiTek® connectors. This design is based only upon parameters shown, and is for an individual building component, not a truss system. Before use, the building designer must verify the applicability of design parameters and properly incorporate this design into the overall building design. Bracing indicated is to prevent buckling of individual truss web and/or chord members only. Additional temporary and permanent bracing is always required for stability and to prevent collapse with possible personal injury and property damage. For general guidance regarding the fabrication, storage, delivery, erection and bracing of trusses and truss systems, see

ANSI/TPI1 Quality Criteria, DSB-89 and BCSI Building Component

Safety Information available from Truss Plate Institute, 2670 Crain Highway, Suite 203 Waldorf, MD 20601



6904 Parke East Blvd.
Tampa, FL 33610

Symbols

PLATE LOCATION AND ORIENTATION

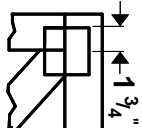

Center plate on joint unless x, y offsets are indicated. Dimensions are in ft-in-sixteenths. Apply plates to both sides of truss and fully embed teeth.

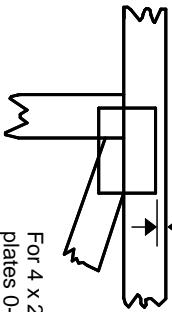

For 4 x 2 orientation, locate plates 0- 1/16" from outside edge of truss.



This symbol indicates the required direction of slots in connector plates.

* Plate location details available in **MITek 20/20 software** or upon request.

PLATE SIZE

4 X 4

The first dimension is the plate width measured perpendicular to slots. Second dimension is the length parallel to slots.

LATERAL BRACING LOCATION

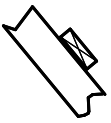

Indicated by symbol shown and/or by text in the bracing section of the output. Use T or I bracing if indicated.

BEARING

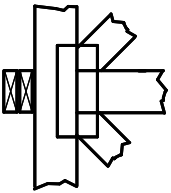

Indicates location where bearings (supports) occur. Icons vary but reaction section indicates joint number where bearings occur. Min size shown is for crushing only.

Industry Standards:

ANSI/TPI 1: National Design Specification for Metal Plate Connected Wood Truss Construction.
DSB-89: Design Standard for Bracing, Building Component Safety Information, Guide to Good Practice for Handling, Installing & Bracing of Metal Plate Connected Wood Trusses.

Numbering System

6-4-8 dimensions shown in ft-in-sixteenths (Drawings not to scale)

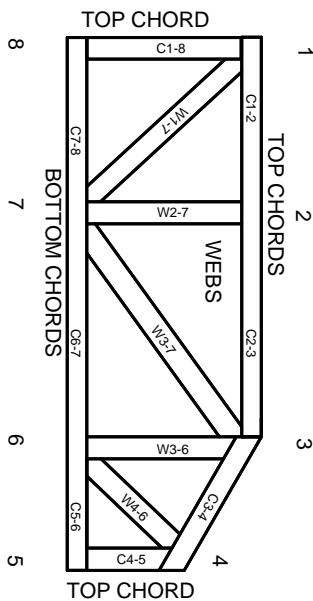

JOINTS ARE GENERALLY NUMBERED/LETTERED CLOCKWISE AROUND THE TRUSS STARTING AT THE JOINT FARTHEST TO THE LEFT.

CHORDS AND WEBS ARE IDENTIFIED BY END JOINT NUMBERS/LETTERS.

PRODUCT CODE APPROVALS

ICC-ES Reports:

ESR-1311, ESR-1352, ESR1988
ER-3907, ESR-2362, ESR-1397, ESR-3282

Trusses are designed for wind loads in the plane of the truss unless otherwise shown.

Lumber design values are in accordance with ANSI/TPI 1 section 6.3 These truss designs rely on lumber values established by others.

© 2012 MITek® All Rights Reserved

General Safety Notes

Failure to Follow Could Cause Property Damage or Personal Injury

1. Additional stability/bracing for truss system, e.g. diagonal or X-bracing, is always required. See BCSI.
2. Truss bracing must be designed by an engineer. For wide truss spacing, individual lateral braces themselves may require bracing, or alternative T or I bracing should be considered.
3. Never exceed the design loading shown and never stack materials on inadequately braced trusses.
4. Provide copies of this truss design to the building designer, erection supervisor, property owner and all other interested parties.
5. Cut members to bear tightly against each other.
6. Place plates on each face of truss at each joint and embed fully. Knots and wane at joint locations are regulated by ANSI/TPI 1.
7. Design assumes trusses will be suitably protected from the environment in accord with ANSI/TPI 1.
8. Unless otherwise noted, moisture content of lumber shall not exceed 19% at time of fabrication.
9. Unless expressly noted, this design is not applicable for use with fire retardant, preservative treated, or green lumber.
10. Camber is a non-structural consideration and is the responsibility of truss fabricator. General practice is to camber for dead load deflection.
11. Plate type, size, orientation and location dimensions indicated are minimum plating requirements.
12. Lumber used shall be of the species and size, and in all respects, equal to or better than that specified.
13. Top chords must be sheathed or purlins provided at spacing indicated on design.
14. Bottom chords require lateral bracing at 10 ft. spacing, or less, if no ceiling is installed, unless otherwise noted.
15. Connections not shown are the responsibility of others.
16. Do not cut or alter truss member or plate without prior approval of an engineer.
17. Install and load vertically unless indicated otherwise.
18. Use of green or treated lumber may pose unacceptable environmental, health or performance risks. Consult with project engineer before use.
19. Review all portions of this design (front, back, words and pictures) before use. Reviewing pictures alone is not sufficient.
20. Design assumes manufacture in accordance with ANSI/TPI 1 Quality Criteria.
21. The design does not take into account any dynamic or other loads other than those expressly stated.



MITek Engineering Reference Sheet: Mill-7473 rev. 5/19/2020