

FLORIDA DEPARTMENT OF  
**Business & Professional Regulation**



[BCIS Home](#) | [Log In](#) | [User Registration](#) | [Hot Topics](#) | [Submit Surcharge](#) | [Stats & Facts](#) | [Publications](#) | [Contact Us](#) | [BCIS Site Map](#) | [Links](#) | [Search](#)



**Product Approval**  
USER : Public User



[Product Approval Menu](#) > [Product or Application Search](#) > [Application List](#) > **Application Detail**

▶ OFFICE OF THE  
SECRETARY

**FL #** FL19562-R9  
**Application Type** Revision  
**Code Version** 2023  
**Application Status** Approved

**Comments**  
 Archived

**Product Manufacturer**  
**Address/Phone/Email**  
 Andersen Corporation  
 100 Fourth Avenue North  
 Bayport, MN 55003  
 (651) 264-5308  
 alan.barstad@AndersenCorp.com

**Authorized Signature**  
 Alan Barstad  
 alan.barstad@AndersenCorp.com

**Technical Representative**  
**Address/Phone/Email**

**Quality Assurance Representative**  
**Address/Phone/Email**  
 Alan Barstad  
 100 Fourth Avenue North  
 Bayport, MN 55003  
 (651) 264-5308  
 abarstad@andersencorp.com

**Category** Windows  
**Subcategory** Fixed

**Compliance Method**  
 Evaluation Report from a Florida Registered Architect or a Licensed Florida Professional Engineer  
 Evaluation Report - Hardcopy Received

**Florida Engineer or Architect Name who developed the Evaluation Report** Hermes F. Norero, P.E.  
**Florida License** PE-73778  
**Quality Assurance Entity** Window and Door Manufacturers Association-QA  
**Quality Assurance Contract Expiration Date** 12/01/2030  
**Validated By** Zachary R. Priest, P.E.  
 Validation Checklist - Hardcopy Received

**Certificate of Independence**  
[FL19562\\_R9\\_COI\\_Andersen\\_SS\\_2021-10-18.pdf](#)

Referenced Standard and Year (of Standard)	Standard	Year
	AAMA/WDMA/CSA 101/I.S. 2/A440	2011
	AAMA/WDMA/CSA 101/I.S. 2/A440	2017

ASTM E1886	2013
ASTM E1996	2017
TAS 201	1994
TAS 202	1994
TAS 203	1994

Equivalence of Product Standards  
Certified By

Sections from the Code

Product Approval Method

Method 1 Option D

Date Submitted 12/14/2023  
 Date Validated 12/27/2023  
 Date Pending FBC Approval 01/02/2024  
 Date Approved 02/13/2024

**Summary of Products**

FL #	Model, Number or Name	Description
19562.1	Renewal by Andersen Casement Window - Fixed (HVHZ) (Impact)	Renewal by Andersen Casement Window - Fixed (HVHZ) (Impact)
<p><b>Limits of Use</b>                      Approved for use in HVHZ: Yes                      Approved for use outside HVHZ: Yes                      Impact Resistant: Yes                      Design Pressure: +60/-70                      Other: See Installation Details and Evaluation Report for allowable sizes, configurations, installation requirements and limits of use.</p>		
19562.2	Renewal by Andersen Casement Window - Fixed (Non-HVHZ)(Non-Impact)	Renewal by Andersen Casement Window - Fixed (Non-HVHZ) (Non-Impact)
<p><b>Limits of Use</b>                      Approved for use in HVHZ: No                      Approved for use outside HVHZ: Yes                      Impact Resistant: No                      Design Pressure: N/A                      Other: See Installation Instructions and Evaluation report for allowable design pressures, sizes, installation requirements and limits of use.</p>		

19562.3	Renewal by Andersen Fixed Window - (HVHZ)(Impact)	Renewal by Andersen Fixed Window - (HVHZ)(Impact)
<p><b>Limits of Use</b>                      Approved for use in HVHZ: Yes                      Approved for use outside HVHZ: Yes                      Impact Resistant: Yes                      Design Pressure: N/A                      Other: See Installation Instructions and Evaluation report for allowable design pressures, sizes, installation requirements and limits of use.</p>		
<p><b>Installation Instructions</b>  <a href="#">E119562_R9_II_AWD094.SS.2020-10-11.pdf</a>                      Verified By: Hermes F. Norero, P.E. FL PE No. 73778                      Created by Independent Third Party: Yes  <b>Evaluation Reports</b>  <a href="#">E119562_R9_AE_PER6698.SS.2020-10-11.pdf</a>                      Created by Independent Third Party: Yes</p>		

19562.4	Renewal by Andersen Fixed Window - Full Frame (Non-HVHZ)(Non-Impact)	Renewal by Andersen Fixed Window - Full Frame (Non-HVHZ) (Non-Impact)
<p><b>Limits of Use</b>                      Approved for use in HVHZ: Yes                      Approved for use outside HVHZ: Yes                      Impact Resistant: Yes                      Design Pressure: N/A                      Other: See Installation Instructions and Evaluation report for allowable design pressures, sizes, installation requirements and limits of use.</p>		
<p><b>Installation Instructions</b>  <a href="#">E119562_R9_II_AWD292.SS.2021-06-15.pdf</a>                      Verified By: Hermes F. Norero, P.E. Florida P.E. 73778                      Created by Independent Third Party: Yes  <b>Evaluation Reports</b>  <a href="#">E119562_R9_AE_PER7621.SS.2021-06-15.pdf</a>                      Created by Independent Third Party: Yes</p>		

<p><b>Limits of Use</b>                      Approved for use in HVHZ: No                      Approved for use outside HVHZ: Yes</p>		
<p><b>Installation Instructions</b>  <a href="#">E119562_R9_II_AWD092.SS.2020-10-11.pdf</a>                      Verified By: Hermes F. Norero, P.E. FL PE No. 73778</p>		

<p><b>Impact Resistant:</b> No  <b>Design Pressure:</b> N/A  <b>Other:</b> See Installation Instructions and Evaluation report for allowable design pressures, sizes, installation requirements and limits of use.</p>		<p>Created by Independent Third Party : Yes  <b>Evaluation Reports</b>  <a href="#">FL19562_R9_AE_PER66696_SS_2020-10-11.pdf</a>                      Created by Independent Third Party : Yes</p>
19562.5	<p>Renewal by Andersen Fixed Window - Insert Frame (Non-HVHZ)(Non-Impact)</p>	<p>Renewal by Andersen Fixed Window - Insert Frame (Non-HVHZ)(Non-Impact)</p>
<p><b>Limits of Use</b>  <b>Approved for use in HVHZ:</b> No  <b>Approved for use outside HVHZ:</b> Yes  <b>Impact Resistant:</b> No  <b>Design Pressure:</b> N/A  <b>Other:</b> See Installation Instructions and Evaluation report for allowable design pressures, sizes, installation requirements and limits of use.</p>		<p><b>Installation Instructions</b>  <a href="#">FL19562_R9_II_AWD091_SS_2020-10-11.pdf</a>                      Verified By : Hermes F. Norero, P.E. FL PE No. 73778                      Created by Independent Third Party : Yes  <b>Evaluation Reports</b>  <a href="#">FL19562_R9_AE_PER66696_SS_2020-10-11.pdf</a>                      Created by Independent Third Party : Yes</p>
19562.6	<p>Renewal by Andersen Fixed Window - Universal Frame (Non-HVHZ)(Non-Impact)</p>	<p>Renewal by Andersen Fixed Window - Universal Frame (Non-HVHZ)(Non-Impact)</p>
<p><b>Limits of Use</b>  <b>Approved for use in HVHZ:</b> No  <b>Approved for use outside HVHZ:</b> Yes  <b>Impact Resistant:</b> No  <b>Design Pressure:</b> N/A  <b>Other:</b> See Installation Instructions and Evaluation report for allowable design pressures, sizes, installation requirements and limits of use.</p>		<p><b>Installation Instructions</b>  <a href="#">FL19562_R9_II_AWD244_SS_2023-11-28.pdf</a>                      Verified By : Hermes F. Norero, P.E. FL PE No. 73778                      Created by Independent Third Party : Yes  <b>Evaluation Reports</b>  <a href="#">FL19562_R9_AE_PER8980_SS_2023-11-28.pdf</a>                      Created by Independent Third Party : Yes</p>

[Back](#)

[Next](#)

Contact Us :: 2601 Blair Stone Road, Tallahassee, FL 32399 Phone: 850-487-1824

The State of Florida is an AA/EEO employer. Copyright 2007-2013 State of Florida. :: [Privacy Statement](#) :: [Accessibility Statement](#) :: [Refund Statement](#)

Under Florida law, email addresses are public records. If you do not want your e-mail address released in response to a public-records request, do not send electronic mail to this entity. Instead, contact the office by phone or by traditional mail. If you have any questions, please contact 850.487.1395. \*Pursuant to Section 455.275(1), Florida Statutes, effective October 1, 2012, licensees licensed under Chapter 455, F.S., must provide the Department with an email address if they have one. The emails provided may be used for official communication with the licensee. However, email addresses are public record. If you do not wish to supply a personal address, please provide the Department with an email address which can be made available to the public. To determine if you are a licensee under Chapter 455, F.S., please click [here](#).

**Product Approval Accepts:**



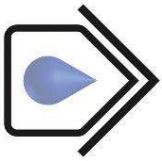

# b. HxH mx 5# 16

w1 6 W x B  
r v b v 5S4, L0

u40 shpV Vg V g h  
w uu0  
pV Vg V em uuvt  
4, th440t L0 RC  
4, thlttt Lu0 mT  
V @ h

1 W 5

5 W F  
W - h A-  
T#TAg(, RT#TAM1WF2R

-)1-)cvuit

5 T e i i v i

F - b F

M Y c-x W W R  
F Y h  
6 -F Y - h

1 Y 5 w - h A-  
M Y - T#TAg(, RT#TAM1WF2R  
1 x Y 6 H H 1gF Smh xfvT

w F  
cff - w T  
b SMT uuf fo

1 Y  
( -eT S1Aw  
m VR V s 8 LULLO  
pV 5v4lvtlSvsV

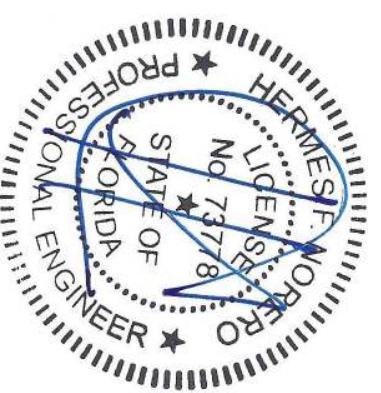

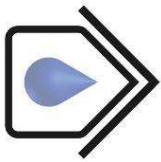

# b. НХН mx 5# 16

# N rN r N

w1 6 W x B  
r V b V 5S4, L0

M Y W F

1 F Y )

1 6 Æ Y m )

F M Y wV R b V 2 adra n

1 T Y 5 w - h A- -  
T#TAg(, RT#TAM1wF2R

6 Y x VR s V V W C nh# eRtsham 8 LULLOn w

F V V 2 d wV m VR b Vem Vp V  
g V R V W V cm Vg r h

C nh# eRtsh V V V V V  
V V V h V V V

x V V V V r m Vg  
r h V V V r m Vg

w f V V f wh xfvte V V C nh# eRtsham 8 LULLOn  
V V V h

) . Y dh x V V V V r m Vg r e  
the "High Velocity Hurricane Zone" (HVHZ).

Sh R V V V V V V h b  
V V V V V h

uh ) r V df r m Vg r V \_\_\_\_ V V V  
h

th w V V V V f V V f wh xfvte  
w f V V f wh xfvte V V h

C nh# eRtsh  
m VRtsh# hLULLO  
RV S t

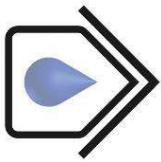

# b. НХН mx 5# 16

w1 6 W x B  
r v b v 5S4, L0

# N rN r N

9 w y x v v v v v v v v  
 r m v g r v v v h x  
 v v v v v v arg r / v v 851MbS, d, n

1 6 y x v v v v 5

- bb2 bl) p2 bl r wb d v d l f n w s l b t t v o d d

5 x y dh R x v w 2  
 arg r / v v 8 x w x d l 4, n p v 5v, l v s l d s  
 W 5g L, S l h v d s v d d t l c w p v 5v, l v s l d s  
 W 5g L, S 4 h v d s v d d t l c w p v 5v, l v s l d s  
 W 5g L, S 0 h v d s v d d t l c w p v 5v, l v s l d s  
 W 5s 4 4 s v v d s v d d t l c w p v 5v 4 l s, l d,  
 W 5s 4 4 d 4 v d s v d d t l c w p v 5v 4 l s, l d,  
 W 5s 4 4 s d v d s v d d t l c w p v 5v 4 l s, l d,  
 W 5g L, S 4 h v s s v d d t l c w p v 5v, l v s l d s  
 W 5g L, S 0 h v s s v d d t l c w p v 5v, l v s l d s

Sh 1 v b v w  
 h x M  
 arg r / v v 851 MbS, d, n

H y w f v v f a n h x f v t n e e v v v  
 v v h

x 1 y w f v v f a n h x f v t n v e e v  
 v h

C mh# eRsh  
 m vRsh# hLULLO  
 RV u t

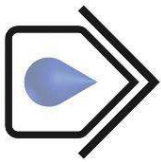

# b. НХН mx 5# 16

# N rN r N

w1 6 W x B  
r v b v 5S4, L0

W 2 6 Y

(v v v v v v v e v e  
b r v v v m vg r h  
v v a r b

dn bb2 bl) p2 blrwb dvdll ffwsl bittvav0

r v u, m Vg r v  
v v 5

1) bb2 bl) p2 blrwb dvdll ffwsl bittvadd

b v v v v e v v v  
v v h v hb v v v v

C mh# eRsh  
m V Rsh# hLULLO  
RV t t







AWD092 (0.27.PAK) 15/06/2015 10:58:00 AM

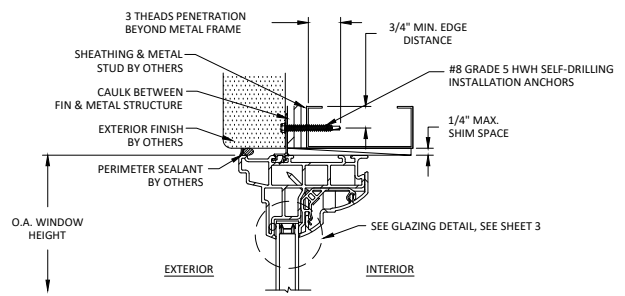

**A**  
**4** VERTICAL SECTION  
HEAD - METAL FRAME SUBSTRATE  
NAIL FIN

NAIL FIN/FLANGE IS REVERSIBLE. SEE  
ORIENTATION DIFFERENCE IN DETAIL  
A AND B

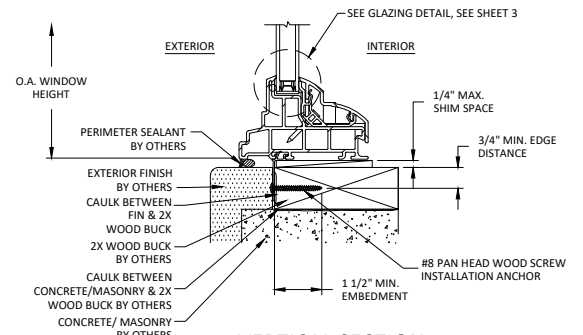

**B**  
**4** VERTICAL SECTION  
SILL - 2X WOOD BUCK  
NAIL FIN

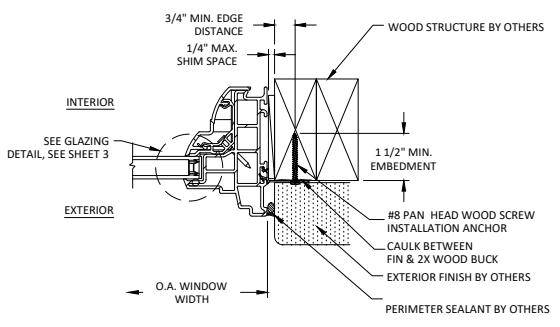

**C**  
**4** HORIZONTAL SECTION  
JAMB - WOOD BUCK  
NAIL FIN

**ANDERSEN**  
WINDOWS & DOORS  
100 FOURTH AVE NORTH  
BAYPORT, MN 55003-1096  
PH: (651) 264-9350 FX: (651) 264-5485

TITLE: REVISION BY ANDERSEN FINED  
WINDOWS & DOORS  
(NON-HIGH/IMPACT)  
INSTALLATION CLIP DETAILS

PREPARED BY: BUILDING DROPS, INC.  
308 E. DANA BEACH BLVD, STE. 338  
DANA BEACH, FL 33404  
PH: (561) 44-4738  
FX: (561) 44-4738  
WEB: www.buildingdrops.com

REMARKS	BY	DATE
REV. FOR PG50 UNITS	MS	2.15.16
FBC UPDATE	SM	2.17.18
7TH FBC CODE CHANGE	SR	3.24.20

THE INSTALLATION DETAILS DESCRIBED HEREIN ARE GENERAL AND MAY NOT REFLECT ACTUAL CONDITIONS FOR A SPECIFIC SITE. IF SITE CONDITIONS REQUIRE MODIFICATION TO DERIVE FROM THE REQUIREMENTS DETAILED HEREIN, A LICENSED ENGINEER OR ARCHITECT SHALL PREPARE SITE SPECIFIC DOCUMENTS FOR USE WITH THIS DOCUMENT.

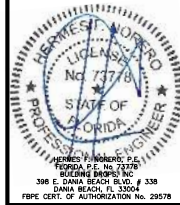

FL #: **FL19562**

DATE: **12.17.15**

DWG. BY: **SM** CHK. BY: **MSS**

SCALE: **NTS**

DWG. #: **AWD092**

SHEET:

**4**

OF 6

145000000 ANDERSEN WINDOW & DOOR SYSTEMS, INC. 2015 W. MARKET STREET, SUITE 200, BAYPORT, MN 55003-1096  
 145000000 ANDERSEN WINDOW & DOOR SYSTEMS, INC. 2015 W. MARKET STREET, SUITE 200, BAYPORT, MN 55003-1096

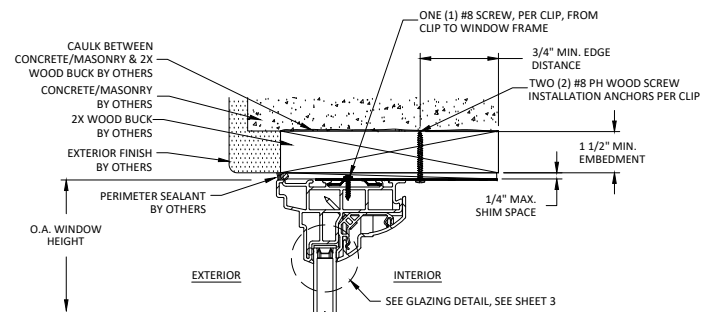

**A**  
5  
**VERTICAL SECTION**  
HEAD - 2X WOOD BUCK  
INSTALLATION CLIP

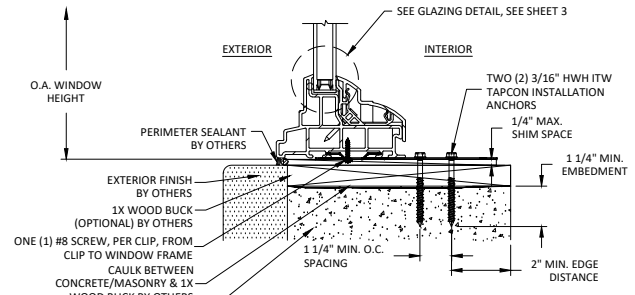

**B**  
5  
**VERTICAL SECTION**  
SILL - 1X WOOD ON CONCRETE/MASONRY  
INSTALLATION CLIP

**INSTALLATION CLIP ANCHOR REQUIREMENTS:**

**WOOD SUBSTRATE:** USE TWO #8 PAN HEAD WOOD SCREWS PER CLIP, IN ROW NUMBER ONE OF PREDRILLED HOLES SHOWN BELOW.

**METAL SUBSTRATE:** USE TWO #8 HWH SMS ANCHORS PER CLIP, IN ROW NUMBER ONE OF PREDRILLED HOLES SHOWN BELOW.

**CONCRETE/MASONRY:** USE TWO 3/16" ITW TAPCON ANCHORS, WITH ONE ANCHOR PLACED IN ROW NUMBER ONE AND ONE ANCHOR PLACED IN ROW NUMBER TWO OF PREDRILLED HOLES SHOWN BELOW. ANCHORS MUST BE PLACED DIAGONALLY ACROSS THE CLIP.

**DO NOT INSTALL ANCHORS THROUGH ROW NUMBER THREE.**

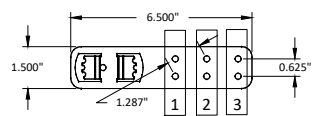

**INSTALLATION CLIP DETAIL**

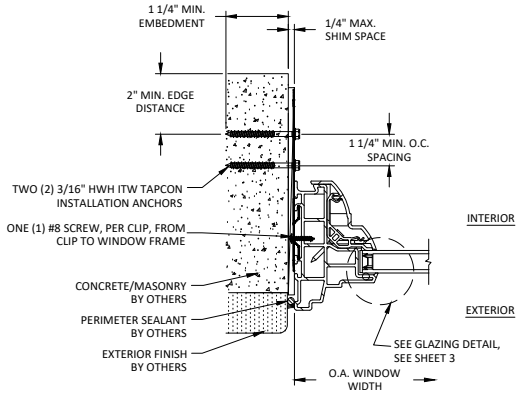

**C**  
5  
**HORIZONTAL SECTION**  
JAMB - CONCRETE/MASONRY  
INSTALLATION CLIP



TITLE: RENEWAL BY ANDERSEN FINED WINDOWS & DOORS (NON-HIGH/NO-IMPACT) INSTALLATION CLIP DETAILS  
 PREPARED BY: BUILDING DROPS, INC.  
 398 E. OAKA BEACH BLVD., STE. 338  
 OAKA BEACH, FL 33064  
 PHONE: (954) 44-4738  
 FAX: (954) 44-4738  
 WWW: www.buildingdrops.com

REMARKS	BY	DATE
REV. FOR PG50 UNITS	MS	2.15.16
FBC UPDATE	SM	2.17.18
7TH FBC CODE CHANGE	SR	3.24.20

THE INSTALLATION DETAILS DESCRIBED HEREIN ARE GENERAL AND MAY NOT REFLECT ACTUAL CONDITIONS FOR A SPECIFIC USE. IF SITE CONDITIONS REQUIRE MODIFICATION TO DERIVE FROM THE REQUIREMENTS DETAILED HEREIN, A LICENSED ENGINEER OR ARCHITECT SHALL PREPARE SITE SPECIFIC DOCUMENTS FOR USE WITH THIS DOCUMENT.

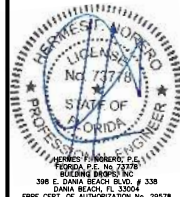

FL #: **FL19562**  
 DATE: **12.17.15**  
 DWG. BY: **SM** CHK. BY: **MSS**  
 SCALE: **NTS**  
 DWG. #: **AWD092**  
 SHEET:

