

COLUMBIA COUNTY Property Appraiser

Parcel 31-3S-16-02414-001

Owners

EDENFIELD SADIE KAY
720 SW GABRIEL PLACE
LAKE CITY, FL 32024

GSA GIS

Pictometry



Parcel Summary

| | |
|--------------|---------------------|
| Location | 688 SW THOMAS TER |
| Use Code | 0100: SINGLE FAMILY |
| Tax District | 3: COUNTY |
| Acreage | 1.0000 |
| Section | 31 |
| Township | 3S |
| Range | 16 |
| Subdivision | DIST 3 |

Legal Description

BEG SE COR OF SE1/4 OF NE1/4, RUN N 210 FT, W 210 FT, S 210 FT, E 210 FT TO POB.

337-643

Working Values

| | 2026 |
|----------------------|----------|
| Total Building | \$93,792 |
| Total Extra Features | \$220 |
| Total Market Land | \$15,000 |
| Total Ag Land | \$0 |

//

| | |
|----------------|-----------|
| | 2026 |
| Total Market | \$109,012 |
| Total Assessed | \$109,012 |
| Total Exempt | \$0 |
| Total Taxable | \$109,012 |
| SOH Diff | \$0 |

Value History

| | | | | | | | |
|----------------------|-----------|-----------|----------|----------|----------|----------|----------|
| | 2025 | 2024 | 2023 | 2022 | 2021 | 2020 | 2019 |
| Total Building | \$93,792 | \$87,929 | \$78,655 | \$68,001 | \$62,533 | \$51,975 | \$47,914 |
| Total Extra Features | \$220 | \$220 | \$220 | \$220 | \$220 | \$220 | \$220 |
| Total Market Land | \$15,000 | \$13,000 | \$13,000 | \$13,000 | \$12,700 | \$12,691 | \$12,691 |
| Total Ag Land | \$0 | \$0 | \$0 | \$0 | \$0 | \$0 | \$0 |
| Total Market | \$109,012 | \$101,149 | \$91,875 | \$81,221 | \$75,453 | \$64,886 | \$60,825 |
| Total Assessed | \$104,043 | \$94,585 | \$85,986 | \$78,169 | \$71,063 | \$64,603 | \$58,730 |
| Total Exempt | \$0 | \$0 | \$0 | \$0 | \$0 | \$0 | \$0 |
| Total Taxable | \$104,043 | \$94,585 | \$85,986 | \$78,169 | \$71,063 | \$64,603 | \$58,730 |
| SOH Diff | \$4,969 | \$6,564 | \$5,889 | \$3,052 | \$4,390 | \$283 | \$2,095 |

Document/Transfer/Sales History

None

Buildings

Building # 1, Section # 1, 51975, SFR

| Type | Models | Heated Sq Ft | Repl Cost New | YrBlt | Year Eff | Gross Area | Other % Dpr | Normal % Dpr | % Cond | Value |
|-------------|-----------|--------------|---------------|-------|----------|------------|-------------|--------------|--------|----------|
| <u>0100</u> | <u>01</u> | 1012 | \$144,295 | 1974 | 1974 | 1,252 | 0.00% | 35.00% | 65.00% | \$93,792 |

Structural Elements

| Type | Description | Code | Details |
|------|-------------------|------|------------|
| EW | Exterior Wall | 31 | VINYL SID |
| RS | Roof Structure | 03 | GABLE/HIP |
| RC | Roof Cover | 14 | PREFIN MT |
| IW | Interior Wall | 05 | DRYWALL |
| IF | Interior Flooring | 14 | CARPET |
| IF | Interior Flooring | 06 | VINYL ASB |
| AC | Air Conditioning | 03 | CENTRAL |
| HT | Heating Type | 04 | AIR DUCTED |

Sub Areas

| Type | Gross Area | Percent of Base | Adjusted Area |
|------------|------------|-----------------|---------------|
| <u>BAS</u> | 1,012 | 100% | 1,012 |
| <u>FSP</u> | 240 | 40% | 96 |

| Type | Description | Code | Details |
|------|----------------------|------|---------|
| BDR | Bedrooms | 3.00 | |
| BTH | Bathrooms | 1.00 | |
| FR | Frame | 01 | NONE |
| STR | Stories | 1. | 1. |
| AR | Architectual Type | 05 | CONV |
| COND | Condition Adjustment | 03 | 03 |
| KTCH | Kitchen Adjustment | 01 | 01 |

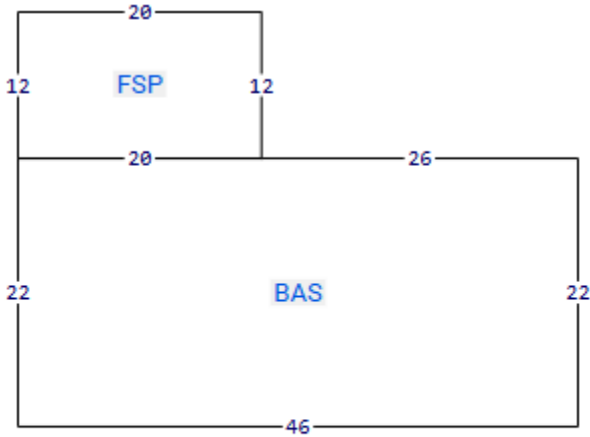

Extra Features

| Code | Description | Length | Width | Units | Unit Price | AYB | % Good Condition | Final Value |
|------|-------------|--------|-------|-------|------------|------|------------------|-------------|
| 0296 | SHED METAL | 8 | 10 | 80.00 | \$5.50 | 1993 | 50% | \$220 |

Land Lines

| Code | Description | Zone | Front | Depth | Units | Rate/Unit | Acreage | Total Adj | Value |
|------|-------------|------|-------|-------|-------|----------------|---------|-----------|----------|
| 0100 | SFR | A-1 | .00 | .00 | 1.00 | \$15,000.00/AC | 1.00 | 1.00 | \$15,000 |

Personal Property

None

Permits

None

TRIM Notices

2025
2024
2023

Disclaimer

All parcel data on this page is for use by the Columbia County Assessor for assessment purposes only. The summary data on this page may not be a complete representation of the parcel or of the improvements thereon. Building information, including unit counts and number of permitted units, should be verified with the appropriate building and planning agencies. Zoning information should be verified with the appropriate planning agency. All parcels are reappraised each year. This is a true and accurate copy of the records of the Columbia County Assessor's Office as of December 10, 2025.

Copyright © 2022 Columbia County. All rights reserved.
