



## **STRUCTURAL DESIGN** **ENCLOSED BUILDING**

**MAXIMUM 30'-0" WIDE X 20'-0" EAVE HEIGHT-  
BOX EAVE FRAME AND BOW FRAME**

**11 December 2020**

**Revision 9**

**M&A Project No.**

**16062S/16155S/16207S/17155S/17200S/18068S/18156S/18290S/20019S/20324S**

**Prepared for:**

**Steel Buildings and Structures, Inc.  
P.O. Box 1287  
Mt. Airy, NC 27030**

**Prepared by:**

**Moore and Associates Engineering  
and Consulting, Inc.**

**1009 East Avenue  
North Augusta, SC 29841**

**401 S. Main St., Suite 200  
Mt. Airy, NC 27030**



**MOORE AND ASSOCIATES  
ENGINEERING AND CONSULTING**

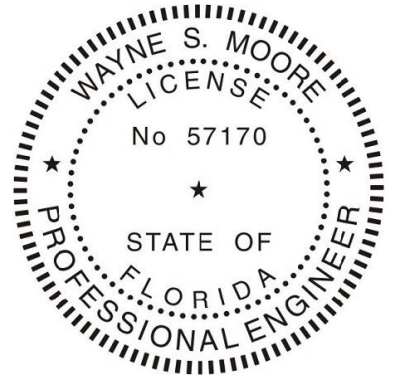

This item has been electronically signed and sealed by Wayne S. Moore, PE. using a Digital Signature and date.

Printed copies of this document are not considered signed and sealed and the signature must be verified on any electronic copies.



This item has been electronically signed and sealed by Wayne S. Moore, PE. using a Digital Signature and date.

Printed copies of this document are not considered signed and sealed and the signature must be verified on any electronic copies.

<b>MOORE AND ASSOCIATES ENGINEERING AND CONSULTING, INC.</b>	<b>DRAWN BY:</b> LT	<b>STEEL BUILDINGS AND STRUCTURES, INC.</b> P.O. BOX 1287, MOUNT AIRY, NC 27030 30'-0"x20'-0" ENCLOSED STRUCTURE		
	<b>CHECKED BY:</b> PDH			
THIS DOCUMENT IS THE PROPERTY OF MOORE AND ASSOCIATES ENGINEERING AND CONSULTING. THE UNAUTHORIZED REPRODUCTION, COPYING, OR OTHERWISE USE OF THIS DOCUMENT IS STRICTLY PROHIBITED AND ANY INFRINGEMENT THEREUPON MAY BE SUBJECT TO LEGAL ACTION.	<b>PROJECT MGR:</b> WSM	<b>DATE:</b> 12-11-20	<b>SCALE:</b> NTS	<b>JOB NO:</b> 18068S/18156S 18290S/20019S/20324S
	<b>CLIENT:</b> SBSI	<b>SHT.</b> 1	<b>DWG. NO:</b> SK-3	<b>REV.:</b> 9



This item has been electronically signed and sealed by Wayne S. Moore, PE. using a Digital Signature and date.

Printed copies of this document are not considered signed and sealed and the signature must be verified on any electronic copies.

<b>MOORE AND ASSOCIATES ENGINEERING AND CONSULTING, INC.</b>	<b>DRAWN BY:</b> LT		STEEL BUILDINGS AND STRUCTURES, INC. P.O. BOX 1287, MOUNT AIRY, NC 27030 30'-0"x20'-0" ENCLOSED STRUCTURE		
	<b>CHECKED BY:</b> PDH				
THIS DOCUMENT IS THE PROPERTY OF MOORE AND ASSOCIATES ENGINEERING AND CONSULTING. THE UNAUTHORIZED REPRODUCTION, COPYING, OR OTHERWISE USE OF THIS DOCUMENT IS STRICTLY PROHIBITED AND ANY INFRINGEMENT THEREUPON MAY BE SUBJECT TO LEGAL ACTION.	<b>PROJECT MGR:</b> WSM		<b>DATE:</b> 12-11-20	<b>SCALE:</b> NTS	<b>JOB NO:</b> 18068S/18156S 18290S/20019S/20324S
	<b>CLIENT:</b> SBSI		<b>SHT.</b> 1A	<b>DWG. NO:</b> SK-3	<b>REV.:</b> 9

# DRAWING INDEX

SHEET 1	PE SEAL COVER SHEET (1 OF 2)
SHEET 1A	PE SEAL COVER SHEET (2 OF 2)
SHEET 2	DRAWING INDEX
SHEET 3	INSTALLATION NOTES AND SPECIFICATIONS
SHEET 4	TYPICAL SIDE AND END ELEVATIONS
SHEET 5	TYPICAL RAFTER/COLUMN FRAME AND SIDE FRAMING SECTION (BOX EAVE STRUCTURE)
SHEET 5A	TYPICAL RAFTER/COLUMN FRAME AND SIDE FRAMING SECTION (BOX EAVE STRUCTURE)
SHEET 5B	TYPICAL RAFTER/COLUMN FRAME AND SIDE FRAMING SECTION (BOX EAVE STRUCTURE)
SHEET 6	COLUMN CONNECTION DETAILS (BOX EAVE STRUCTURE)
SHEET 6A	COLUMN CONNECTION DETAILS (BOX EAVE STRUCTURE)
SHEET 7	TYPICAL RAFTER/COLUMN FRAME AND SIDE FRAMING SECTION (BOW EAVE STRUCTURE)
SHEET 7A	TYPICAL RAFTER/COLUMN FRAME AND SIDE FRAMING SECTION (BOW EAVE STRUCTURE)
SHEET 7B	TYPICAL RAFTER/COLUMN FRAME AND SIDE FRAMING SECTION (BOW EAVE STRUCTURE)
SHEET 8	COLUMN CONNECTION DETAILS (BOW EAVE STRUCTURE)
SHEET 8A	COLUMN CONNECTION DETAILS (BOW EAVE STRUCTURE)
SHEET 9	BASE RAIL ANCHORAGE OPTIONS
SHEET 9A	ADDITIONAL BASE RAIL ANCHORAGE OPTION
SHEET 10	BOX EAVE RAFTER END WALL AND SIDE WALL OPENINGS
SHEET 11	BOW EAVE RAFTER END WALL AND SIDE WALL OPENINGS
SHEET 12	CONNECTION DETAILS
SHEET 13	CONNECTION DETAILS
SHEET 14	BOX EAVE RAFTER LEAN-TO OPTIONS
SHEET 15	BOW EAVE RAFTER LEAN-TO OPTIONS
SHEET 16	VERTICAL ROOF/SIDING OPTION END AND SIDE ELEVATION AND SECTION
SHEET 17	SIDE WALL AND END WALL HEADER OPTIONS
SHEET 18	OPTIONAL BASE RAIL ON GRADE APPLICATION
SHEET 19	OPTIONAL BASE RAIL ON TIMBER BEAM
SHEET 20	OPTIONAL BASE RAIL ON TIMBER BEAM WITH SOIL NAIL
SHEET 21	OPTIONAL CONCRETE STRIP FOOTING



This item has been electronically signed and sealed by Wayne S. Moore, PE, using a Digital Signature and date.

Printed copies of this document are not considered signed and sealed and the signature must be verified on any electronic copies.

<b>MOORE AND ASSOCIATES ENGINEERING AND CONSULTING, INC.</b>	DRAWN BY: LT	STEEL BUILDINGS AND STRUCTURES, INC. P.O. BOX 1287, MOUNT AIRY, NC 27030 30'-0"x20'-0" ENCLOSED STRUCTURE			
	CHECKED BY: PDH				
THIS DOCUMENT IS THE PROPERTY OF MOORE AND ASSOCIATES ENGINEERING AND CONSULTING. THE UNAUTHORIZED REPRODUCTION, COPYING, OR OTHERWISE USE OF THIS DOCUMENT IS STRICTLY PROHIBITED AND ANY INFRINGEMENT THEREUPON MAY BE SUBJECT TO LEGAL ACTION.	PROJECT MGR: WSM	DATE: 12-11-20	SCALE: NTS	JOB NO: 18068S/18156S 18290S/20019S/20324S	
	CLIENT: SBSI	SHT. 2	DWG. NO: SK-3	REV: 9	

## INSTALLATION NOTES AND SPECIFICATIONS

1. DESIGN IS FOR MAXIMUM 30'-0" WIDE x 20'-0" EAVE HEIGHT ENCLOSED STRUCTURES.
2. DESIGN WAS DONE IN ACCORDANCE WITH THE 2020 FLORIDA BUILDING CODE (FBC) 7TH EDITION, 2018 NORTH CAROLINA BUILDING CODE, 2006 INTERNATIONAL BUILDING CODE (IBC), 2009 IBC, 2012 IBC, 2015 IBC AND 2018 IBC.
3. DESIGN LOADS ARE AS FOLLOWS:
  - A) DEAD LOAD = 15 PSF
  - B) LIVE LOAD = 12 PSF
  - C) GROUND SNOW LOAD = 30 PSF ( $\leq 26'-0"$ ), 35 PSF ( $26'-0" < W \leq 30'-0"$ )  
NOTE: (UNBALANCED SNOW LOADS DUE TO DRIFTING HAVE NOT BEEN EVALUATED).
4. 3-SECOND GUST ULTIMATE WIND SPEED ( $V_{ULT}$ ) = 105 TO 145 MPH (NOMINAL WIND SPEED = 82 TO 112 MPH)
5. MAXIMUM RAFTER/COLUMN AND END COLUMN SPACING = 50 FEET (UNLESS NOTED OTHERWISE).
6. END WALL COLUMNS (POSTS) ARE EQUIVALENT TO SIDE WALL POSTS IN SIZE AND SPACING (UNLESS NOTED OTHERWISE).
7. RISK CATEGORY I.
8. WIND EXPOSURE CATEGORY B.
9. SPECIFICATIONS APPLICABLE TO 29 GAUGE METAL PANELS FASTENED DIRECTLY TO 2 1/2" x 2 1/2" - 14 GAUGE TUBE STEEL (TS) FRAMING MEMBERS (UNLESS NOTED OTHERWISE).
10. AVERAGE FASTENER SPACING ON-CENTERS ALONG RAFTERS OR HAT CHANNELS, AND COLUMNS (INTERIOR OR END) = 8 INCHES.
11. FASTENERS CONSIST OF 1/4"x3/4" SELF-DRILLING FASTENER (SDF), USE CONTROL SEAL WASHER WITH EXTERIOR FASTENERS. SPECIFICATIONS APPLICABLE ONLY FOR MEAN ROOF HEIGHT OF 20 FEET OR LESS, AND ROOF SLOPES OF 14° (3:12 PITCH) OR LESS SPACING REQUIREMENTS FOR OTHER ROOF HEIGHTS AND/OR SLOPES MAY VARY. ROOF SLOPES LESS THAN 3:12 REQUIRE USE OF LAP JOINT SEALANT.
12. GROUND ANCHORS SHALL BE INSTALLED THROUGH BASE RAIL WITHIN 6" OF EACH COLUMN.
13. STANDARD GROUND ANCHORS (SOIL NAILS) CONSIST OF #4 REBAR W/ WELDED NUT x 36" LONG AND MAY BE USED IN SUITABLE SOILS. OPTIONAL ANCHORAGE MAY BE USED IN SUITABLE SOILS AND MUST BE USED IN UNSUITABLE SOILS AS NOTED.
14. WIND FORCES GOVERN OVER SEISMIC FORCES. SEISMIC PARAMETERS ANALYZED ARE:  
SOIL SITE CLASS = D  
RISK CATEGORY I  
R= 325                       $I_C = 10$   
 $S_{DS} = 2039 g$                $V = C_S W$   
 $S_{M1} = 1258 g$
15. WINDOW AND DOOR DESIGN PRESSURES ARE APPLICABLE TO THE STATE OF FLORIDA ONLY.

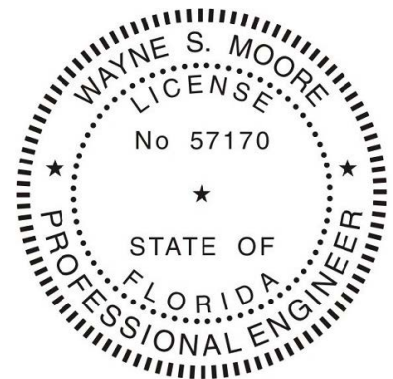

This item has been electronically signed and sealed by Wayne S. Moore, PE. using a Digital Signature and date.

Printed copies of this document are not considered signed and sealed and the signature must be verified on any electronic copies.

**MOORE AND ASSOCIATES  
ENGINEERING AND CONSULTING, INC.**

**DRAWN BY:** LT

**CHECKED BY:** PDH

**PROJECT MGR:** WSM

**CLIENT:** SBSI

STEEL BUILDINGS AND STRUCTURES, INC.  
P.O. BOX 1287,  
MOUNT AIRY, NC 27030  
30'-0"x20'-0" ENCLOSED STRUCTURE

**DATE:** 12-11-20

**SHT:** 3

**SCALE:** NTS

**DWG. NO:** SK-3

**JOB NO:** 18068S/18156S  
18290S/20019S/20324S

**REV:** 9

THIS DOCUMENT IS THE PROPERTY OF MOORE AND ASSOCIATES ENGINEERING AND CONSULTING. THE UNAUTHORIZED REPRODUCTION, COPYING, OR OTHERWISE USE OF THIS DOCUMENT IS STRICTLY PROHIBITED AND ANY INFRINGEMENT THEREUPON MAY BE SUBJECT TO LEGAL ACTION.

### BOX EAVE FRAME RAFTER STRUCTURE

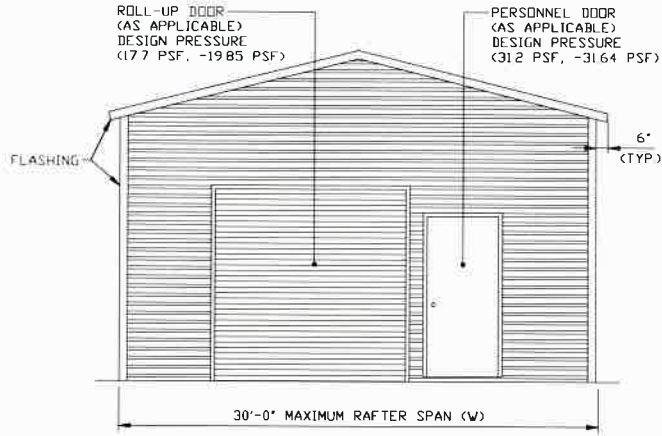

**TYPICAL END ELEVATION**

SCALE: NTS

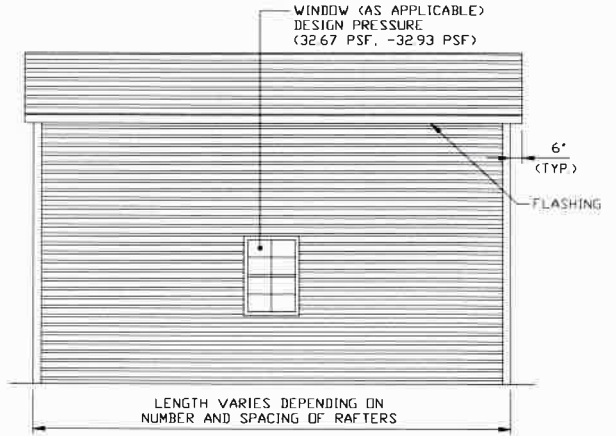

**TYPICAL SIDE ELEVATION**

SCALE: NTS

### BOW EAVE FRAME RAFTER STRUCTURE

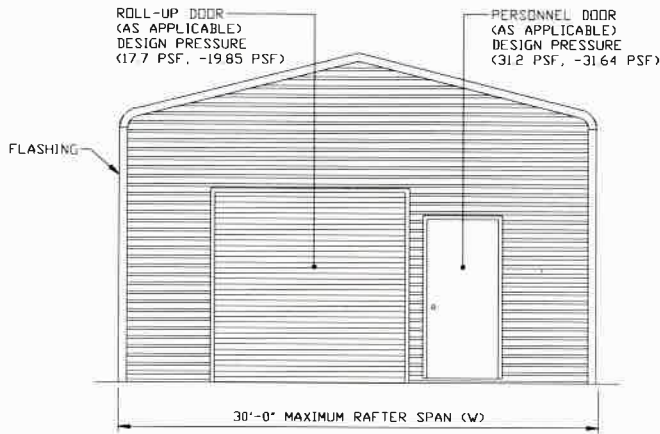

**TYPICAL END ELEVATION**

SCALE: NTS

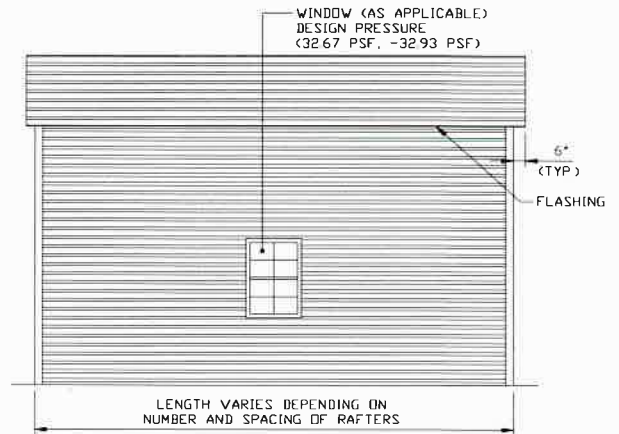

**TYPICAL SIDE ELEVATION**

SCALE: NTS



This item has been electronically signed and sealed by Wayne S. Moore, PE. using a Digital Signature and date.

Printed copies of this document are not considered signed and sealed and the signature must be verified on any electronic copies.

**MOORE AND ASSOCIATES  
ENGINEERING AND CONSULTING, INC.**

DRAWN BY: LT

CHECKED BY: PDH

PROJECT MGR: WSH

CLIENT: SBSI

STEEL BUILDINGS AND STRUCTURES, INC.  
P.O. BOX 1287,  
MOUNT AIRY, NC 27030  
30'-0"x20'-0" ENCLOSED STRUCTURE

DATE: 12-11-20

SHT. 4

SCALE: NTS

DWG. NO: SK-3

JOB NO: 18068S/18156S  
18290S/20019S/20324S

REV: 9

THIS DOCUMENT IS THE PROPERTY OF MOORE AND ASSOCIATES ENGINEERING AND CONSULTING. THE UNAUTHORIZED REPRODUCTION, COPYING, OR OTHERWISE USE OF THIS DOCUMENT IS STRICTLY PROHIBITED AND ANY INFRINGEMENT THEREUPON MAY BE SUBJECT TO LEGAL ACTION.

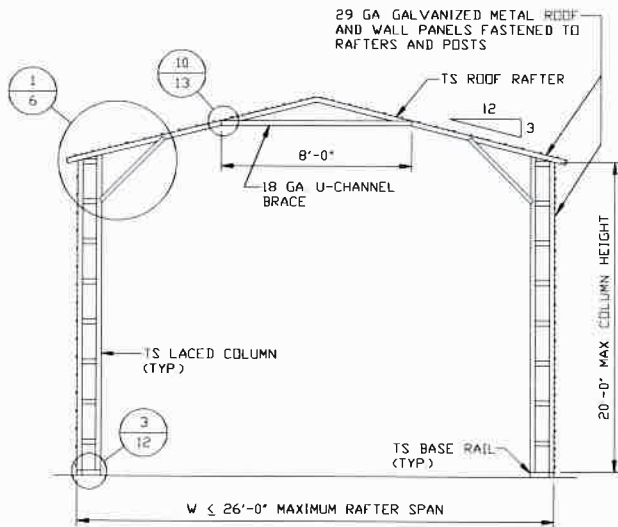

**TYPICAL RAFTER/COLUMN FRAME SECTION**  
SCALE: NTS

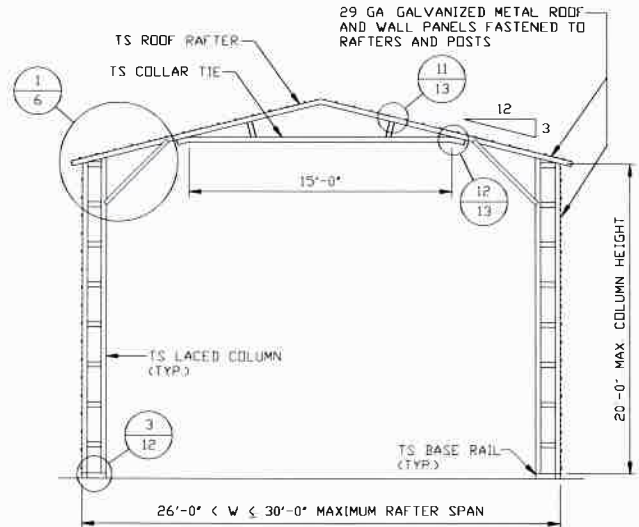

**TYPICAL RAFTER/COLUMN FRAME SECTION**  
SCALE: NTS

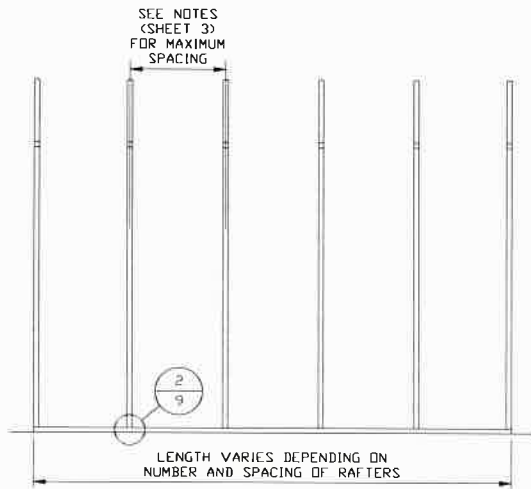

**TYPICAL RAFTER/COLUMN SIDE FRAMING SECTION**  
SCALE: NTS

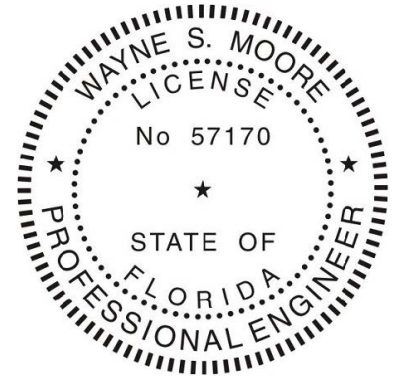

This item has been electronically signed and sealed by Wayne S. Moore, PE. using a Digital Signature and date.

Printed copies of this document are not considered signed and sealed and the signature must be verified on any electronic copies.

**MOORE AND ASSOCIATES  
ENGINEERING AND CONSULTING, INC.**

**DRAWN BY: LT**

**CHECKED BY: PDH**

**PROJECT MGR: WSM**

**CLIENT: SBSI**

**STEEL BUILDINGS AND STRUCTURES, INC.**  
P.O. BOX 1287,  
MOUNT AIRY, NC 27030  
30'-0"x20'-0" ENCLOSED STRUCTURE

**DATE: 12-11-20**

**SHT. 5**

**SCALE: NTS**

**DWG. NO: SK-3**

**JOB NO: 18068S/18156S  
18290S/20019S/20324S**

**REV: 9**

THIS DOCUMENT IS THE PROPERTY OF MOORE AND ASSOCIATES ENGINEERING AND CONSULTING. THE UNAUTHORIZED REPRODUCTION, COPYING, OR OTHERWISE USE OF THIS DOCUMENT IS STRICTLY PROHIBITED AND ANY INFRINGEMENT THEREUPON MAY BE SUBJECT TO LEGAL ACTION.

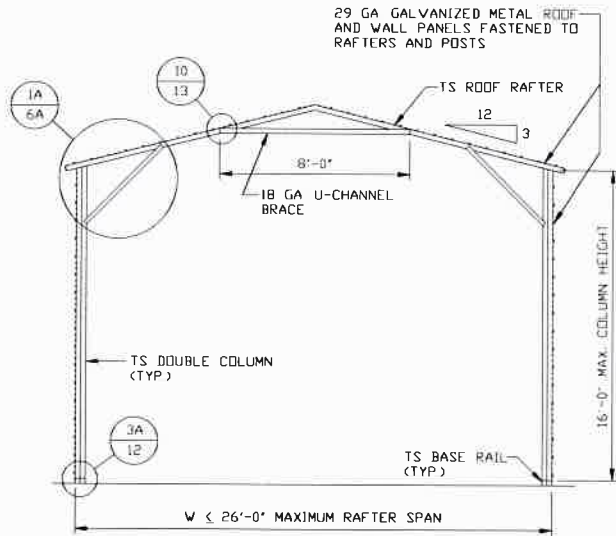

**TYPICAL RAFTER/COLUMN FRAME SECTION**  
SCALE: NTS

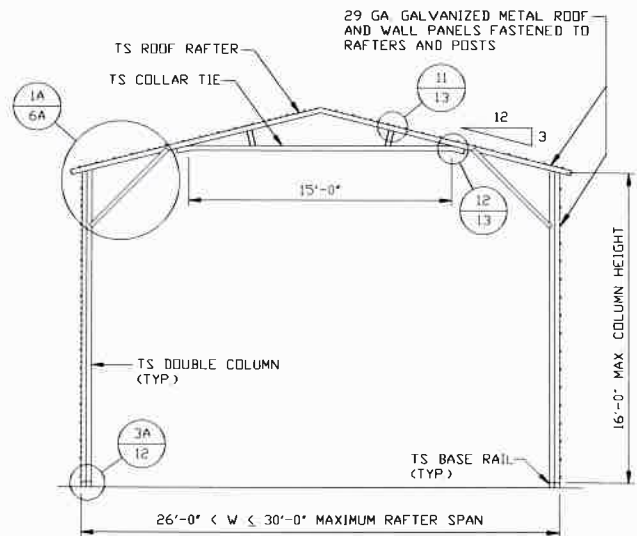

**TYPICAL RAFTER/COLUMN FRAME SECTION**  
SCALE: NTS

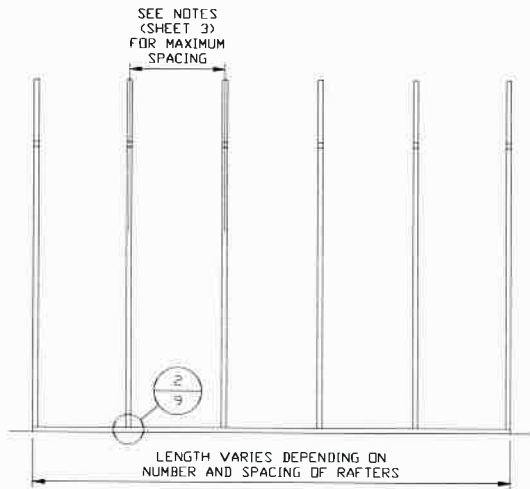

**TYPICAL RAFTER/COLUMN SIDE FRAMING SECTION**  
SCALE: NTS

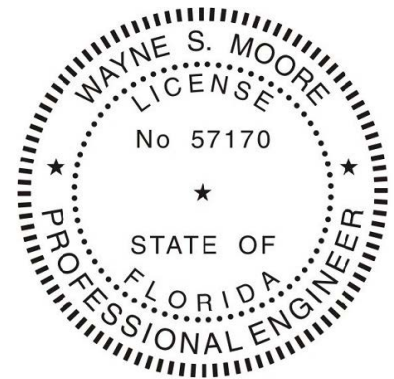

This item has been electronically signed and sealed by Wayne S. Moore, PE. using a Digital Signature and date.

Printed copies of this document are not considered signed and sealed and the signature must be verified on any electronic copies.

**MOORE AND ASSOCIATES  
ENGINEERING AND CONSULTING, INC.**

**DRAWN BY: LT**

**CHECKED BY: PDH**

**PROJECT MGR: WSM**

**CLIENT: SBSI**

**STEEL BUILDINGS AND STRUCTURES, INC.**  
P.O. BOX 1287,  
MOUNT AIRY, NC 27030  
30'-0"X20'-0" ENCLOSED STRUCTURE

**DATE: 12-11-20**

**SHT. 5A**

**SCALE: NTS**

**DWG. NO: SK-3**

**JOB NO: 18068S/18156S  
18290S/20019S/20324S**

**REV: 9**

THIS DOCUMENT IS THE PROPERTY OF MOORE AND ASSOCIATES ENGINEERING AND CONSULTING. THE UNAUTHORIZED REPRODUCTION, COPYING, OR OTHERWISE USE OF THIS DOCUMENT IS STRICTLY PROHIBITED AND ANY INFRINGEMENT THEREUPON MAY BE SUBJECT TO LEGAL ACTION.

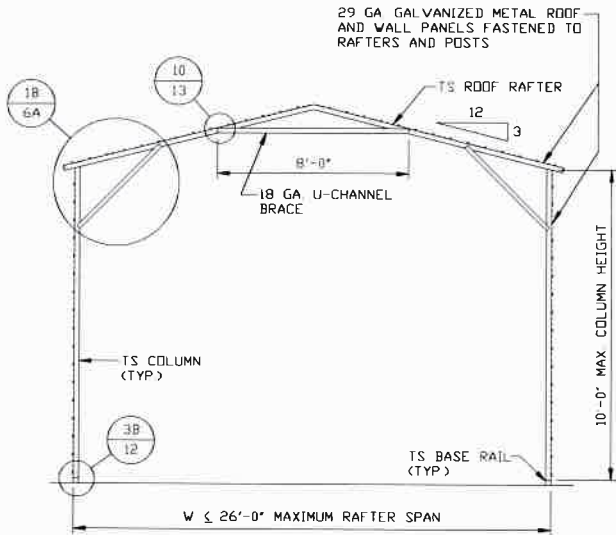

**TYPICAL RAFTER/COLUMN FRAME SECTION**  
SCALE: NTS

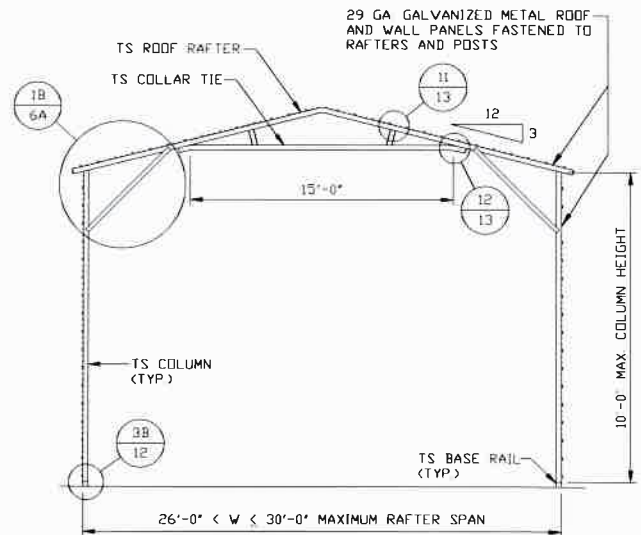

**TYPICAL RAFTER/COLUMN FRAME SECTION**  
SCALE: NTS

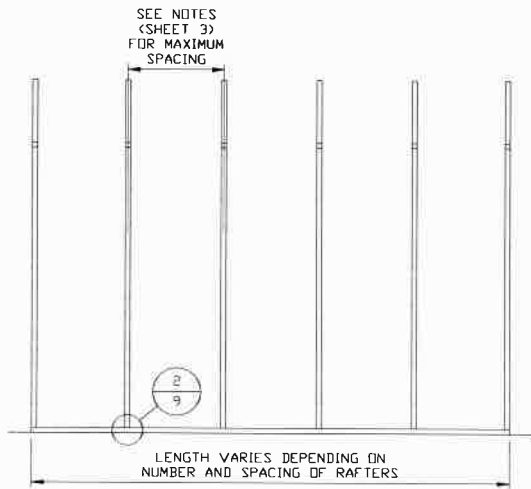

**TYPICAL RAFTER/COLUMN SIDE FRAMING SECTION**  
SCALE: NTS



This item has been electronically signed and sealed by Wayne S. Moore, PE. using a Digital Signature and date.

Printed copies of this document are not considered signed and sealed and the signature must be verified on any electronic copies.

**MOORE AND ASSOCIATES  
ENGINEERING AND CONSULTING, INC.**

**DRAWN BY:** LT

**CHECKED BY:** PDH

**PROJECT MGR:** WSM

**CLIENT:** SBSI

STEEL BUILDINGS AND STRUCTURES, INC.  
P.O. BOX 1287,  
MOUNT AIRY, NC 27030  
30'-0" x 20'-0" ENCLOSED STRUCTURE

**DATE:** 12-11-20

**SHT.** 5B

**SCALE:** NTS

**DWG. NO.:** SK-3

**JOB NO.:** 18068S/18156S  
18290S/20019S/20324S

**REV.:** 9

THIS DOCUMENT IS THE PROPERTY OF MOORE AND ASSOCIATES ENGINEERING AND CONSULTING. THE UNAUTHORIZED REPRODUCTION, COPYING, OR OTHERWISE USE OF THIS DOCUMENT IS STRICTLY PROHIBITED AND ANY INFRINGEMENT THEREUPON MAY BE SUBJECT TO LEGAL ACTION.

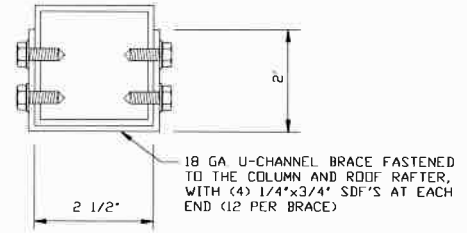
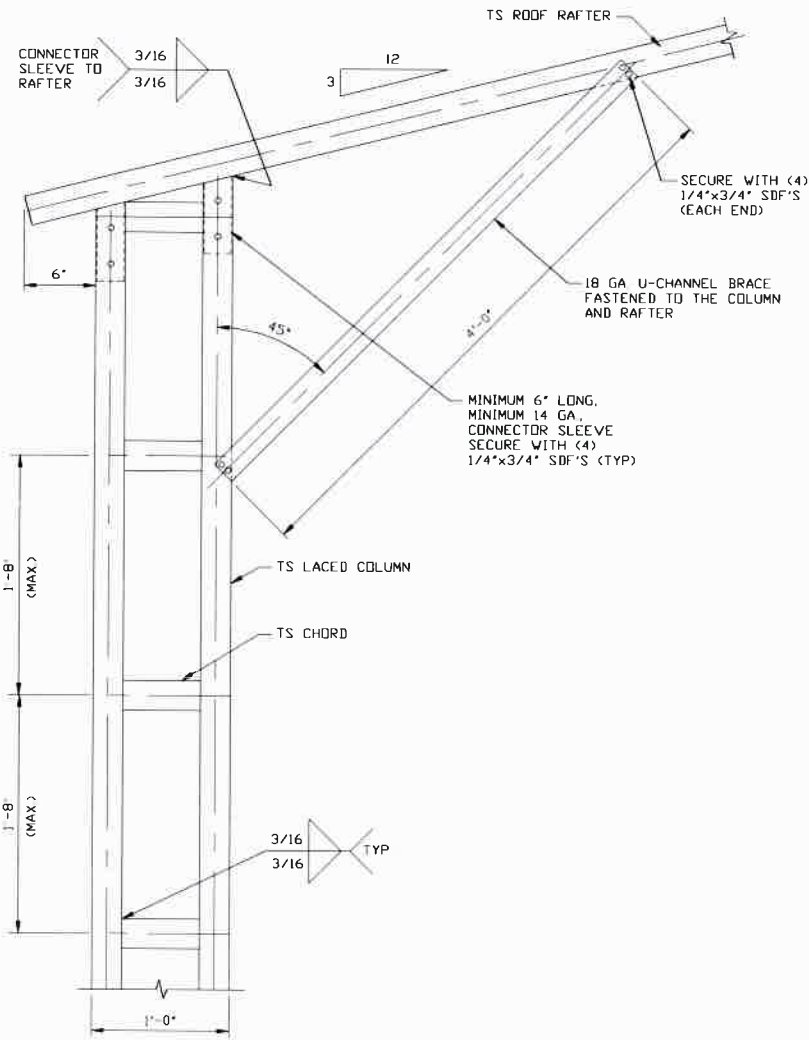

**BRACE SECTION**

SCALE: NTS

**BOX EAVE RAFTER/CORNER POST CONNECTION DETAIL FOR HEIGHTS 16'-0" < TO ≤ 20'-0"**

SCALE: NTS

1

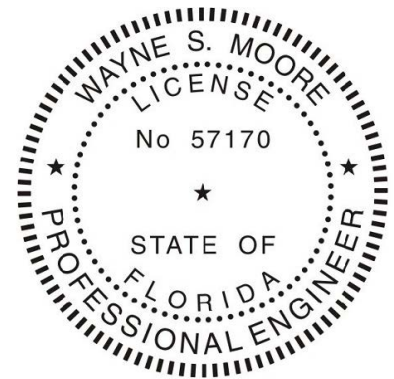

This item has been electronically signed and sealed by Wayne S. Moore, PE. using a Digital Signature and date.

Printed copies of this document are not considered signed and sealed and the signature must be verified on any electronic copies.

**MOORE AND ASSOCIATES ENGINEERING AND CONSULTING, INC.**

DRAWN BY: LT

CHECKED BY: PDH

PROJECT MGR: WSM

CLIENT: SBSI

STEEL BUILDINGS AND STRUCTURES, INC.  
P.O. BOX 1287,  
MOUNT AIRY, NC 27030  
30'-0"x20'-0" ENCLOSED STRUCTURE

DATE: 12-11-20

SCALE: NTS

JOB NO 18068S/18156S  
18290S/20019S/20324S

SHT. 6

DWG. NO: SK-3

REV: 9

THIS DOCUMENT IS THE PROPERTY OF MOORE AND ASSOCIATES ENGINEERING AND CONSULTING. THE UNAUTHORIZED REPRODUCTION, COPYING, OR OTHERWISE USE OF THIS DOCUMENT IS STRICTLY PROHIBITED AND ANY INFRINGEMENT THEREUPON MAY BE SUBJECT TO LEGAL ACTION.



**1A** BOX EAVE RAFTER/CORNER POST CONNECTION DETAIL FOR HEIGHTS 10'-0" < TO ≤ 16'-0" SCALE: NTS

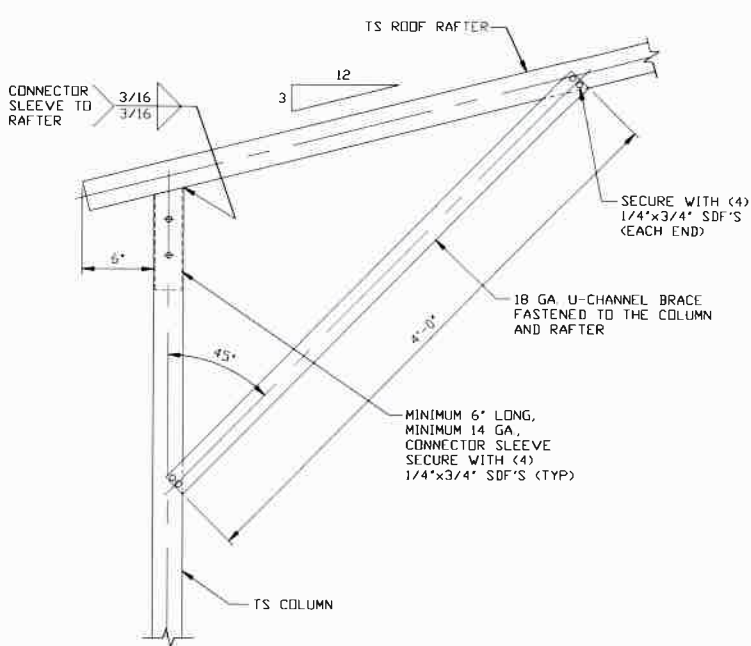

**1B** BOX EAVE RAFTER/CORNER POST CONNECTION DETAIL FOR HEIGHTS ≤ 10'-0" SCALE: NTS

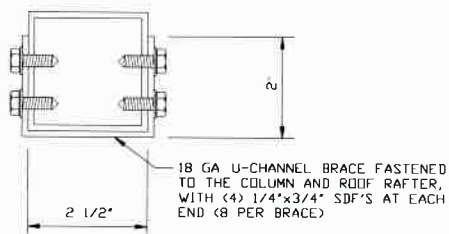

**BRACE SECTION** SCALE: NTS

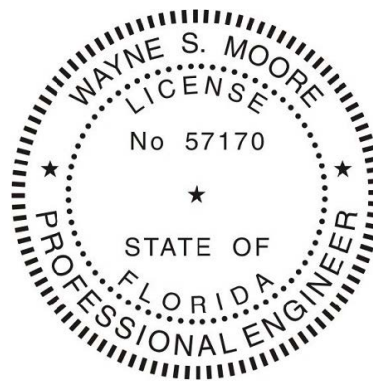

This item has been electronically signed and sealed by Wayne S. Moore, PE. using a Digital Signature and date.

Printed copies of this document are not considered signed and sealed and the signature must be verified on any electronic copies.

**MOORE AND ASSOCIATES ENGINEERING AND CONSULTING, INC.**

**DRAWN BY: LT**

**CHECKED BY: PDH**

**PROJECT MGR: WSM**

**CLIENT: SBSI**

**STEEL BUILDINGS AND STRUCTURES, INC.**  
P.O. BOX 1287,  
MOUNT AIRY, NC 27030  
30'-0" x 20'-0" ENCLOSED STRUCTURE

**DATE: 12-11-20**

**SHT. 6A**

**SCALE: NTS**

**DWG. NO: SK-3**

**JOB NO: 18068S/18156S  
18290S/20019S/20324S**

**REV: 9**

THIS DOCUMENT IS THE PROPERTY OF MOORE AND ASSOCIATES ENGINEERING AND CONSULTING. THE UNAUTHORIZED REPRODUCTION, COPYING, OR OTHERWISE USE OF THIS DOCUMENT IS STRICTLY PROHIBITED AND ANY INFRINGEMENT THEREUPON MAY BE SUBJECT TO LEGAL ACTION.

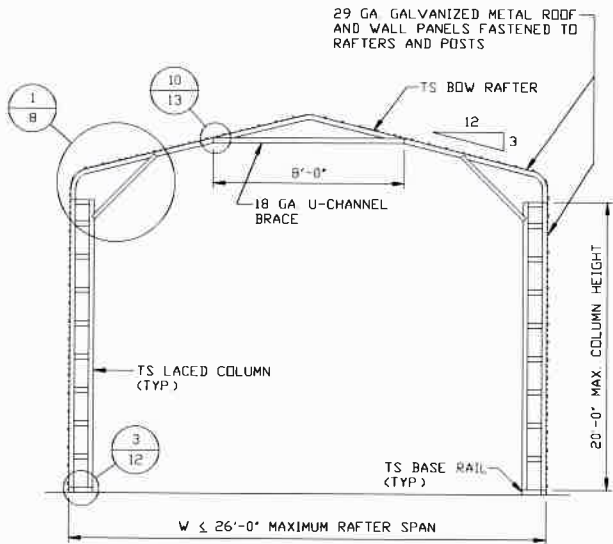

**TYPICAL RAFTER/COLUMN FRAME SECTION**  
SCALE: NTS

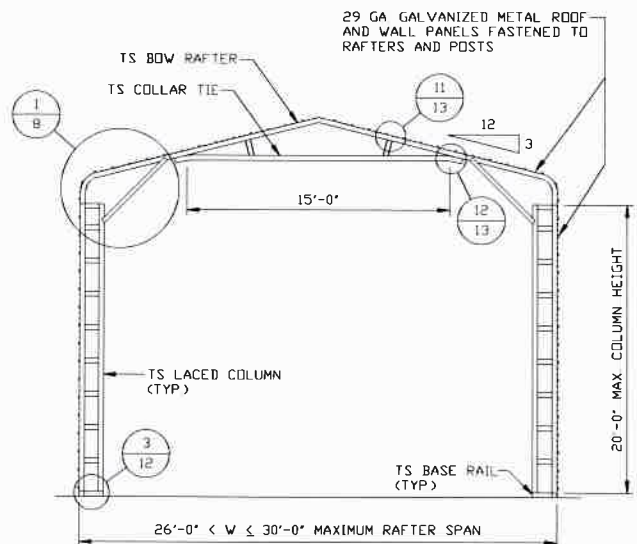

**TYPICAL RAFTER/COLUMN FRAME SECTION**  
SCALE: NTS

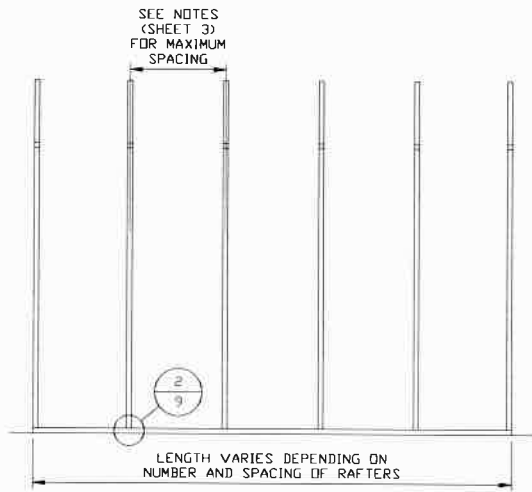

**TYPICAL RAFTER/COLUMN SIDE FRAMING SECTION**  
SCALE: NTS

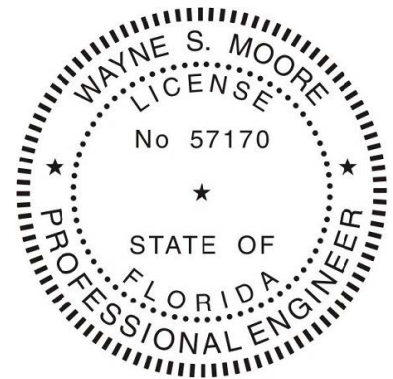

This item has been electronically signed and sealed by Wayne S. Moore, PE. using a Digital Signature and date.

Printed copies of this document are not considered signed and sealed and the signature must be verified on any electronic copies.

**MOORE AND ASSOCIATES  
ENGINEERING AND CONSULTING, INC.**

**DRAWN BY: LT**

**CHECKED BY: PDH**

**PROJECT MGR: WSM**

**CLIENT: SBSI**

**STEEL BUILDINGS AND STRUCTURES, INC.**  
P.O. BOX 1287,  
MOUNT AIRY, NC 27030  
30'-0"x20'-0" ENCLOSED STRUCTURE

**DATE: 12-11-20**

**SHT. 7**

**SCALE: NTS**

**DWG. NO: SK-3**

**JOB NO: 18068S/18156S  
18290S/20019S/20324S**

**REV: 9**

THIS DOCUMENT IS THE PROPERTY OF MOORE AND ASSOCIATES ENGINEERING AND CONSULTING. THE UNAUTHORIZED REPRODUCTION, COPYING, OR OTHERWISE USE OF THIS DOCUMENT IS STRICTLY PROHIBITED AND ANY INFRINGEMENT THEREUPON MAY BE SUBJECT TO LEGAL ACTION.

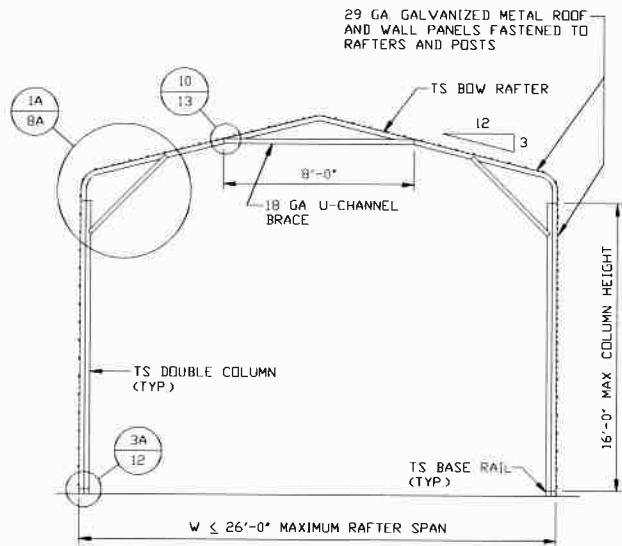

**TYPICAL RAFTER/COLUMN FRAME SECTION**  
SCALE: NTS

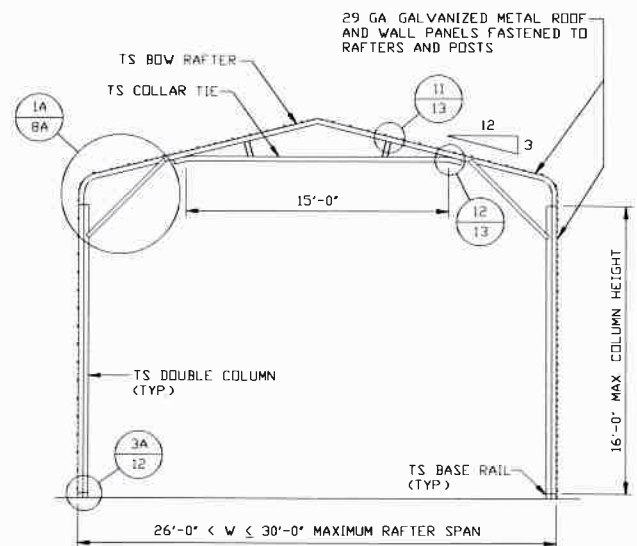

**TYPICAL RAFTER/COLUMN FRAME SECTION**  
SCALE: NTS

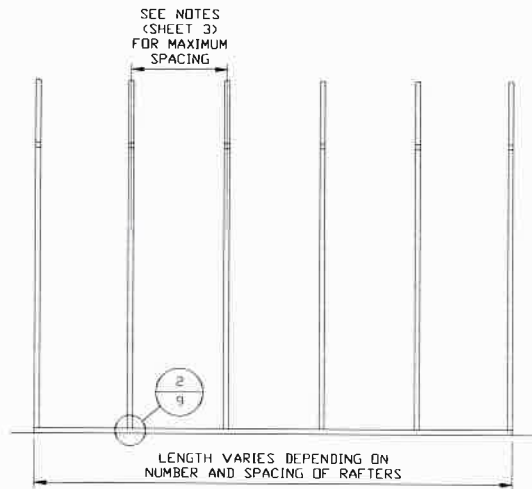

**TYPICAL RAFTER/COLUMN SIDE FRAMING SECTION**  
SCALE: NTS



This item has been electronically signed and sealed by Wayne S. Moore, PE, using a Digital Signature and date.

Printed copies of this document are not considered signed and sealed and the signature must be verified on any electronic copies.

**MOORE AND ASSOCIATES  
ENGINEERING AND CONSULTING, INC.**

**DRAWN BY: LT**

**CHECKED BY: PDH**

**PROJECT MGR: WSM**

**CLIENT: SBSI**

STEEL BUILDINGS AND STRUCTURES, INC.  
P.O. BOX 1287,  
MOUNT AIRY, NC 27030  
30'-0"x20'-0" ENCLOSED STRUCTURE

**DATE: 12-11-20**

**SHT. 7A**

**SCALE: NTS**

**DWG. NO: SK-3**

**JOB NO: 18068S/18156S  
18290S/20019S/20324S**

**REV: 9**

THIS DOCUMENT IS THE PROPERTY OF MOORE AND ASSOCIATES ENGINEERING AND CONSULTING. THE UNAUTHORIZED REPRODUCTION, COPYING, OR OTHERWISE USE OF THIS DOCUMENT IS STRICTLY PROHIBITED AND ANY INFRINGEMENT THEREUPON MAY BE SUBJECT TO LEGAL ACTION.

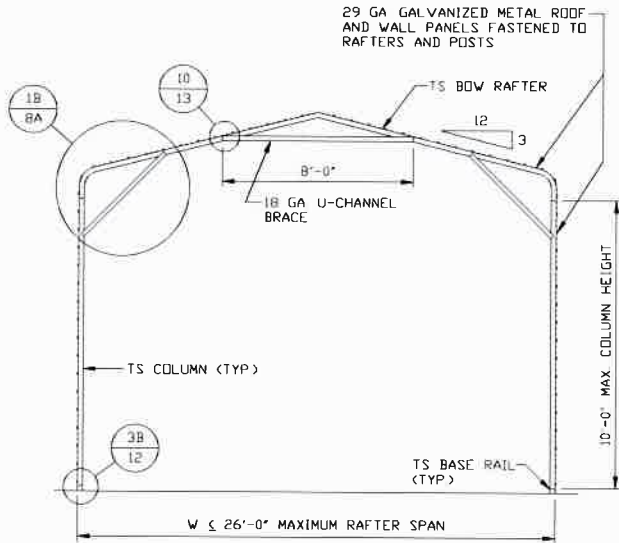

**TYPICAL RAFTER/COLUMN FRAME SECTION**  
SCALE: NTS

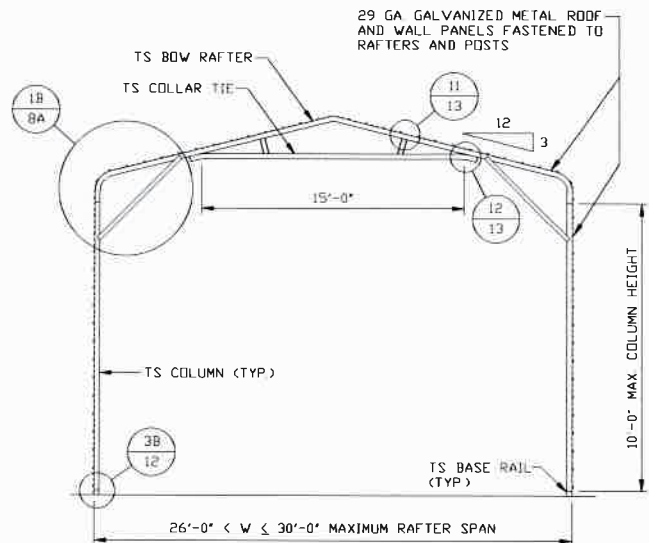

**TYPICAL RAFTER/COLUMN FRAME SECTION**  
SCALE: NTS

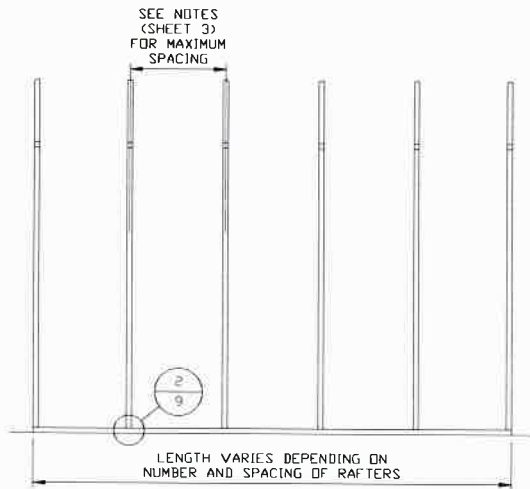

**TYPICAL RAFTER/COLUMN SIDE FRAMING SECTION**  
SCALE: NTS

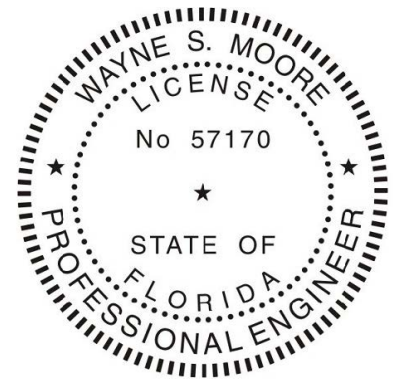

This item has been electronically signed and sealed by Wayne S. Moore, PE. using a Digital Signature and date.

Printed copies of this document are not considered signed and sealed and the signature must be verified on any electronic copies.

**MOORE AND ASSOCIATES  
ENGINEERING AND CONSULTING, INC.**

**DRAWN BY:** LT

**CHECKED BY:** PDH

**PROJECT MGR:** WSH

**CLIENT:** SBSI

STEEL BUILDINGS AND STRUCTURES, INC.  
P.O. BOX 1287,  
MOUNT AIRY, NC 27030  
30'-0"x20'-0" ENCLOSED STRUCTURE

**DATE:** 12-11-20

**SHT:** 7B

**SCALE:** NTS

**DWG. NO:** SK-3

**JOB NO:** 18068S/18156S  
18290S/20019S/20324S

**REV:** 9

THIS DOCUMENT IS THE PROPERTY OF MOORE AND ASSOCIATES ENGINEERING AND CONSULTING. THE UNAUTHORIZED REPRODUCTION, COPYING, OR OTHERWISE USE OF THIS DOCUMENT IS STRICTLY PROHIBITED AND ANY INFRINGEMENT THEREUPON MAY BE SUBJECT TO LEGAL ACTION.

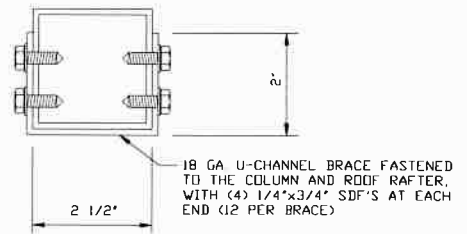
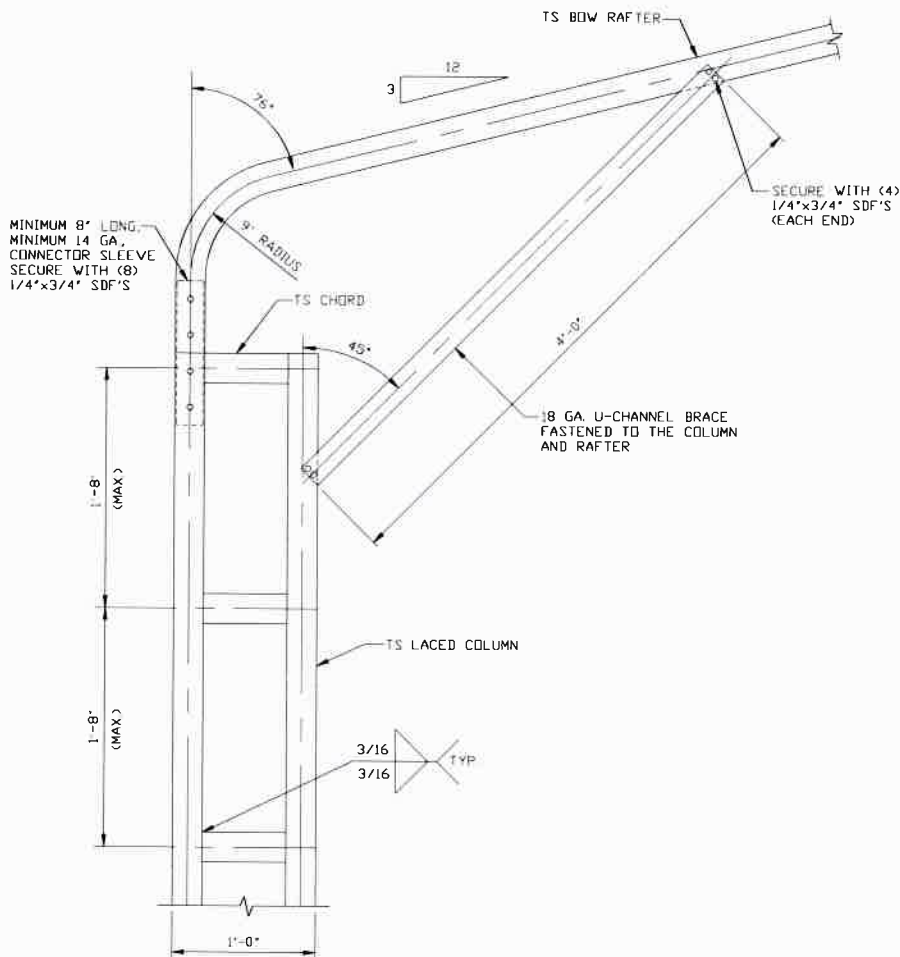

**BRACE SECTION**  
SCALE: NTS

**BOX EAVE RAFTER/CORNER POST CONNECTION DETAIL**  
**FOR HEIGHTS 16'-0" < TO ≤ 20'-0"**  
SCALE: NTS

1

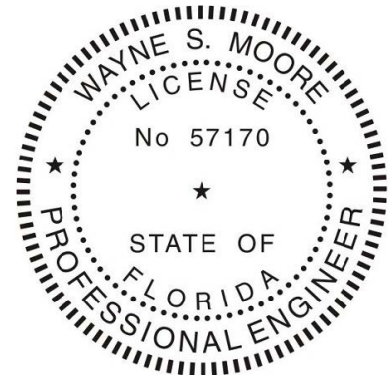

This item has been electronically signed and sealed by Wayne S. Moore, PE, using a Digital Signature and date.

Printed copies of this document are not considered signed and sealed and the signature must be verified on any electronic copies.

**MOORE AND ASSOCIATES ENGINEERING AND CONSULTING, INC.**

**DRAWN BY: LT**

**CHECKED BY: PDH**

**PROJECT MGR: WSM**

**CLIENT: SBST**

STEEL BUILDINGS AND STRUCTURES, INC.  
P.O. BOX 1287,  
MOUNT AIRY, NC 27030  
30'-0"x20'-0" ENCLOSED STRUCTURE

**DATE: 12-11-20**

**SHT. 8**

**SCALE: NTS**

**DWG. NO: SK-3**

**JOB NO: 18068S/18156S  
18290S/20019S/20324S**

**REV: 9**

THIS DOCUMENT IS THE PROPERTY OF MOORE AND ASSOCIATES ENGINEERING AND CONSULTING. THE UNAUTHORIZED REPRODUCTION, COPYING, OR OTHERWISE USE OF THIS DOCUMENT IS STRICTLY PROHIBITED AND ANY INFRINGEMENT THEREUPON MAY BE SUBJECT TO LEGAL ACTION.

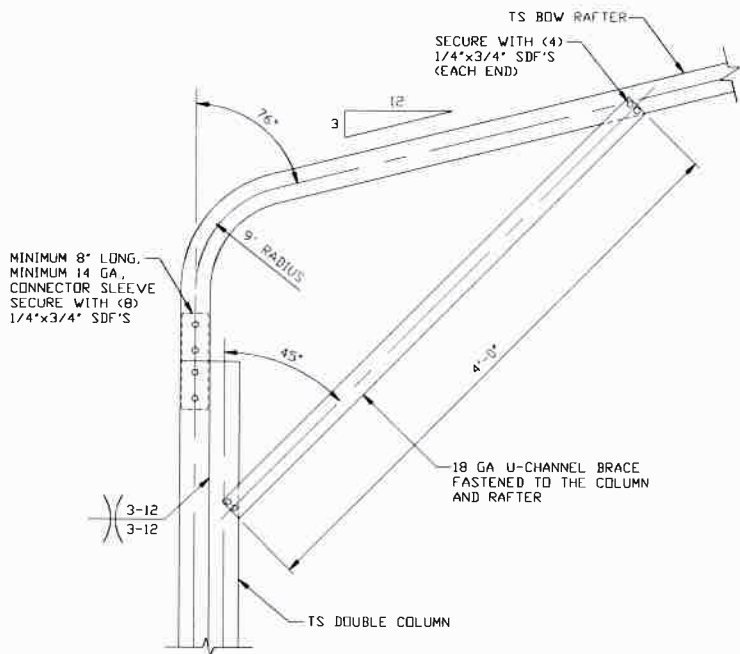

**BOX EAVE RAFTER/CORNER POST CONNECTION DETAIL FOR HEIGHTS 10'-0" < TO <= 16'-0"**

1A

SCALE: NTS

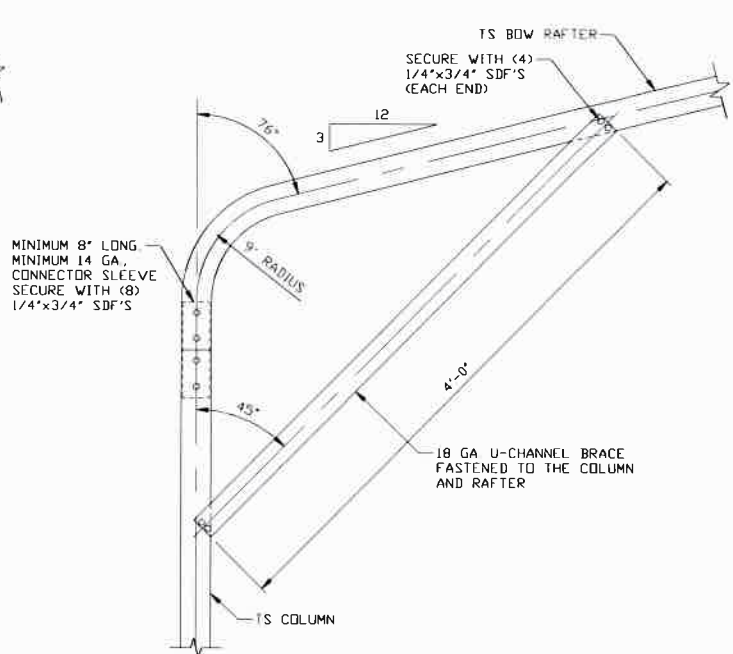

**BOX EAVE RAFTER/CORNER POST CONNECTION DETAIL FOR HEIGHTS <= 10'-0"**

1B

SCALE: NTS

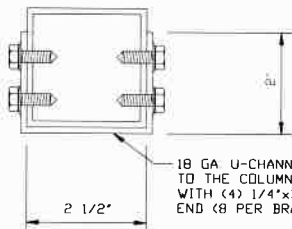

18 GA U-CHANNEL BRACE FASTENED TO THE COLUMN AND ROOF RAFTER, WITH (4) 1/4"x3/4" SDF'S AT EACH END (8 PER BRACE)

**BRACE SECTION**

SCALE: NTS

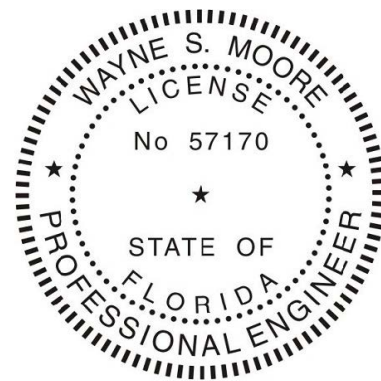

This item has been electronically signed and sealed by Wayne S. Moore, PE, using a Digital Signature and date.

Printed copies of this document are not considered signed and sealed and the signature must be verified on any electronic copies.

**MOORE AND ASSOCIATES ENGINEERING AND CONSULTING, INC.**

DRAWN BY: LT

CHECKED BY: PDH

PROJECT MGR: WSM

CLIENT: SBSI

STEEL BUILDINGS AND STRUCTURES, INC.  
P.O. BOX 1287,  
MOUNT AIRY, NC 27030  
30'-0"x20'-0" ENCLOSED STRUCTURE

DATE: 12-11-20

SHT. 8A

SCALE: NTS

DWG. NO: SK-3

JOB NO: 18068S/18156S  
18290S/20019S/20324S

REV: 9

THIS DOCUMENT IS THE PROPERTY OF MOORE AND ASSOCIATES ENGINEERING AND CONSULTING. THE UNAUTHORIZED REPRODUCTION, COPYING, OR OTHERWISE USE OF THIS DOCUMENT IS STRICTLY PROHIBITED AND ANY INFRINGEMENT THEREUPON MAY BE SUBJECT TO LEGAL ACTION.

# BASE RAIL ANCHORAGE OPTIONS

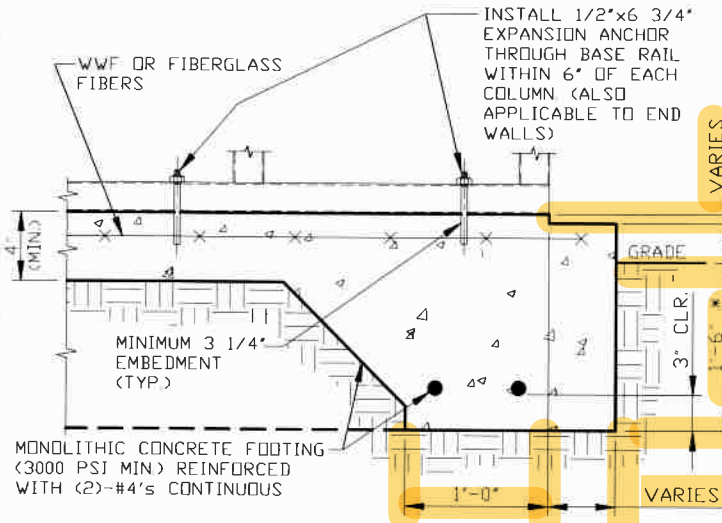

**2 CONCRETE MONOLITHIC SLAB BASE RAIL ANCHORAGE**

SCALE: NTS  
MINIMUM ANCHOR EDGE DISTANCE IS 4"  
\* COORDINATE WITH LOCAL CODES/ORD.

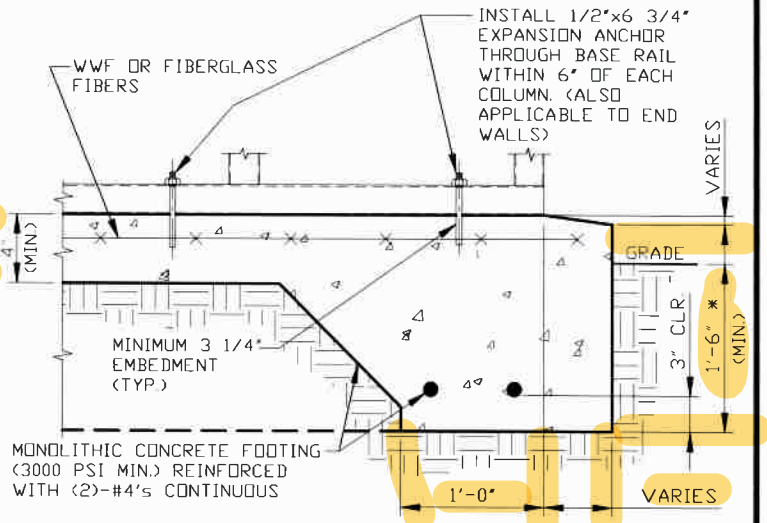

**2A CONCRETE SLAB BASE RAIL ANCHORAGE**

SCALE: NTS  
MINIMUM ANCHOR EDGE DISTANCE IS 4"  
\* COORDINATE WITH LOCAL CODES/ORD.

## GENERAL NOTES

NOTE: CONCRETE MONOLITHIC SLAB DESIGN BASED ON MINIMUM SOIL BEARING CAPACITY OF 1,500 PSF.

### CONCRETE:

CONCRETE SHALL HAVE A MINIMUM SPECIFIED COMPRESSIVE STRENGTH OF 3,000 PSI AT 28 DAYS.

### COVER OVER REINFORCING STEEL:

FOR FOUNDATIONS, MINIMUM CONCRETE COVER OVER REINFORCING BARS SHALL BE PER ACI-318:  
3" IN FOUNDATIONS WHERE THE CONCRETE IS CAST AGAINST AND PERMANENTLY IN CONTACT WITH THE EARTH OR EXPOSED TO THE EARTH OR WEATHER, AND 1 1/2" ELSEWHERE.

### REINFORCING STEEL:

THE TURNDOWN REINFORCING STEEL SHALL BE ASTM A615 GRADE 60. THE SLAB REINFORCEMENT SHALL BE WELDED WIRE FABRIC MEETING ASTM A185 OR FIBERGLASS FIBER REINFORCEMENT.

### REINFORCEMENT MAY BE BENT IN THE SHOP OR THE FIELD PROVIDED:

- 1 REINFORCEMENT IS BENT COLD.
- 2 THE DIAMETER OF THE BEND, MEASURED ON THE INSIDE OF THE BAR, IS NOT LESS THAN SIX-BAR DIAMETERS.
- 3 REINFORCEMENT PARTIALLY EMBEDDED IN CONCRETE SHALL NOT BE FIELD BENT.

### HELIX ANCHOR NOTES:

- 1 FOR VERY DENSE AND/OR CEMENTED SANDS, COARSE GRAVEL AND COBBLES, CALICHE, PRELOADED SILTS AND CLAYS, USE MINIMUM (2) 4" HELICES WITH MINIMUM 30" EMBEDMENT OR SINGLE 6" HELIX WITH MINIMUM 50" EMBEDMENT.
- 2 FOR CORAL USE MINIMUM (2) 4" HELICES WITH MINIMUM 30" EMBEDMENT OR SINGLE 6" HELIX WITH MINIMUM 50" EMBEDMENT.
- 3 FOR MEDIUM DENSE COARSE SANDS, SANDY GRAVELS, VERY STIFF SILTS, AND CLAYS USE MINIMUM (2) 4" HELICES WITH MINIMUM 30 INCH EMBEDMENT OR SINGLE 6" HELIX WITH MINIMUM 50" EMBEDMENT.
- 4 FOR LOOSE TO MEDIUM DENSE SANDS, FIRM TO STIFF CLAYS AND SILTS ALLUVIAL FILL, USE MINIMUM (2) 6" HELICES WITH MINIMUM 50" EMBEDMENT.
- 5 FOR VERY LOSE TO MEDIUM DENSE SANDS, FIRM TO STIFFER CLAYS AND SILTS, ALLUVIAL FILL, USE MINIMUM (2) 8" HELICES WITH MINIMUM 60" EMBEDMENT.

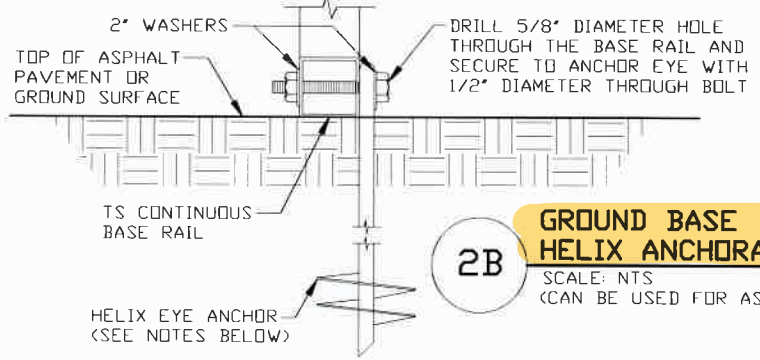

**2B GROUND BASE HELIX ANCHORAGE**

SCALE: NTS  
(CAN BE USED FOR ASPHALT)

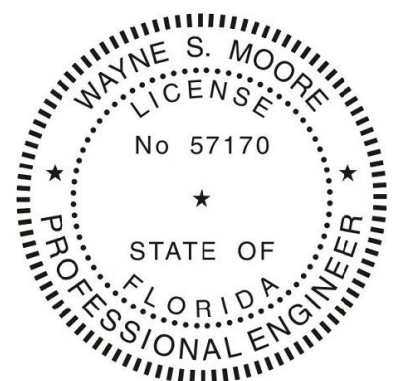

This item has been electronically signed and sealed by Wayne S. Moore, PE. using a Digital Signature and date.

Printed copies of this document are not considered signed and sealed and the signature must be verified on any electronic copies.

**MOORE AND ASSOCIATES ENGINEERING AND CONSULTING, INC.**

DRAWN BY: LT		STEEL BUILDINGS AND STRUCTURES, INC. P.O. BOX 1287, MOUNT AIRY, NC 27030 30'-0"x20'-0" ENCLOSED STRUCTURE			
CHECKED BY: PDH		PROJECT MGR: WSM		DATE: 12-11-20	SCALE: NTS
CLIENT: SBSI		SHT. 9	DWG. NO: SK-3	JOB NO: 18068S/18156S 18290S/20019S/20324S	REV: 9

THIS DOCUMENT IS THE PROPERTY OF MOORE AND ASSOCIATES ENGINEERING AND CONSULTING. THE UNAUTHORIZED REPRODUCTION, COPYING, OR OTHERWISE USE OF THIS DOCUMENT IS STRICTLY PROHIBITED AND ANY INFRINGEMENT THEREUPON MAY BE SUBJECT TO LEGAL ACTION.

# ADDITIONAL BASE RAIL ANCHORAGE OPTION

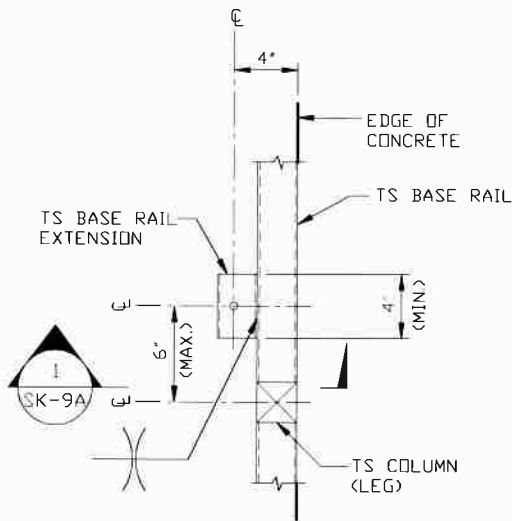

**TYPICAL ANCHOR DETAIL WHEN BASE RAIL IS NEAR EDGE OF CONCRETE**

SCALE: NTS

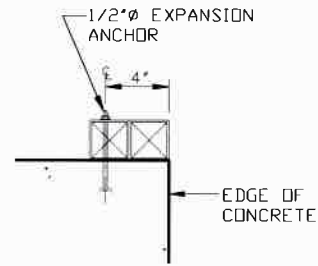

**SECTION 1**

SCALE: NTS

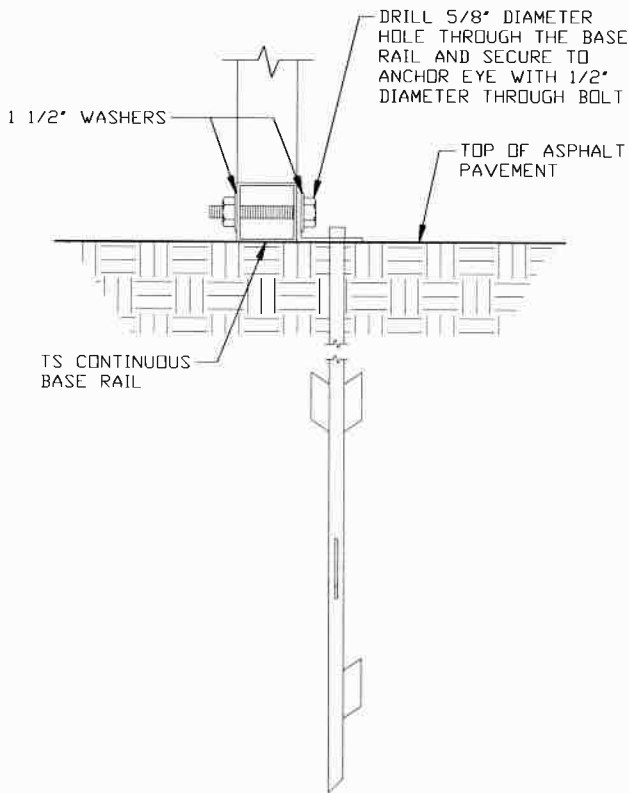

**2C**

**ASPHALT BASE ANCHORAGE**

SCALE: NTS

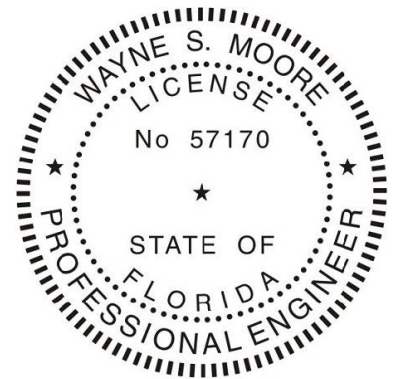

This item has been electronically signed and sealed by Wayne S. Moore, PE, using a Digital Signature and date.

Printed copies of this document are not considered signed and sealed and the signature must be verified on any electronic copies.

**MOORE AND ASSOCIATES  
ENGINEERING AND CONSULTING, INC.**

**DRAWN BY: LT**

**CHECKED BY: PDH**

**PROJECT MGR: WSM**

**CLIENT: SBSI**

**STEEL BUILDINGS AND STRUCTURES, INC.**  
P.O. BOX 1287,  
MOUNT AIRY, NC 27030  
30'-0"X20'-0" ENCLOSED STRUCTURE

**DATE: 12-11-20**

**SHT. 9A**

**SCALE: NTS**

**DWG. NO: SK-3**

**JOB NO: 18068S/18156S  
18290S/20019S/20324S**

**REV: 9**

THIS DOCUMENT IS THE PROPERTY OF MOORE AND ASSOCIATES ENGINEERING AND CONSULTING. THE UNAUTHORIZED REPRODUCTION, COPYING, OR OTHERWISE USE OF THIS DOCUMENT IS STRICTLY PROHIBITED AND ANY INFRINGEMENT THEREUPON MAY BE SUBJECT TO LEGAL ACTION.

# BOX EAVE RAFTER END WALL AND SIDE WALL OPENINGS

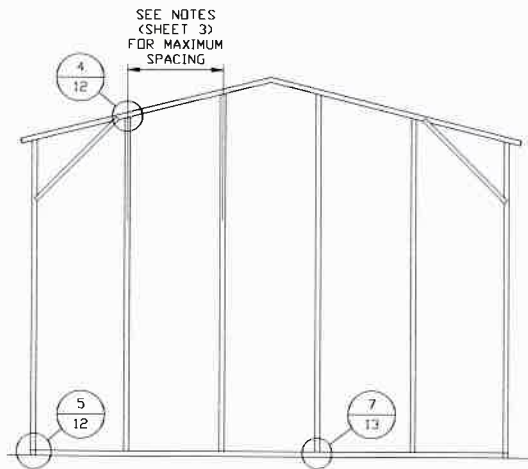

**TYPICAL BOX EAVE RAFTER  
END WALL FRAMING SECTION**

SCALE: NTS

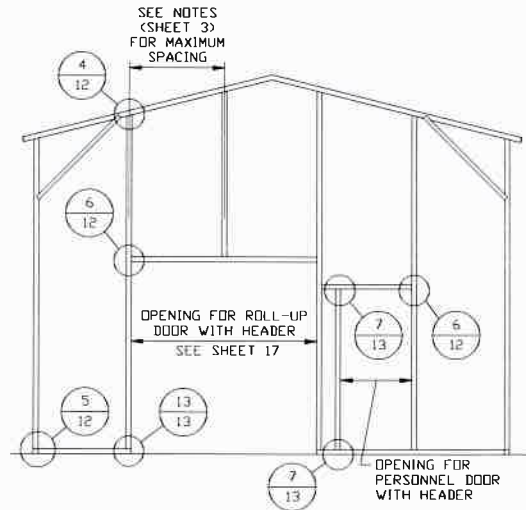

**TYPICAL BOX EAVE RAFTER END  
WALL OPENINGS FRAMING SECTION**

SCALE: NTS

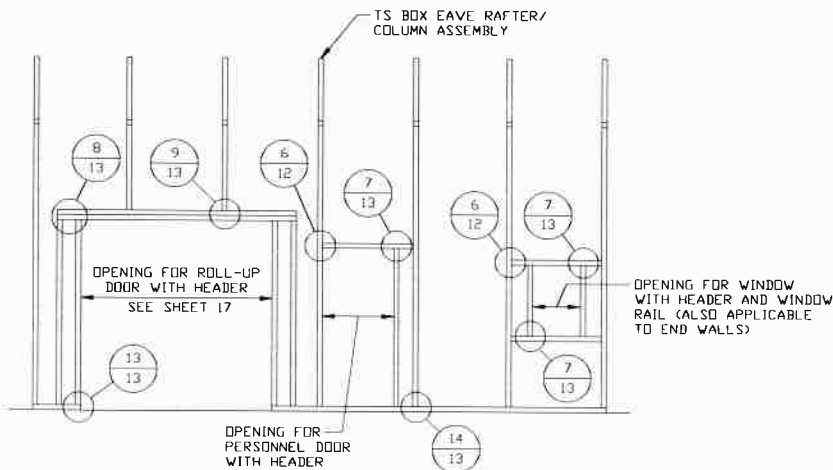

**TYPICAL BOX EAVE RAFTER  
SIDE WALL OPENINGS FRAMING SECTION**

SCALE: NTS

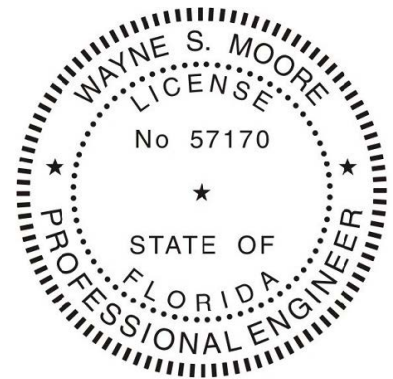

This item has been electronically signed and sealed by Wayne S. Moore, PE. using a Digital Signature and date.

Printed copies of this document are not considered signed and sealed and the signature must be verified on any electronic copies.

**MOORE AND ASSOCIATES  
ENGINEERING AND CONSULTING, INC.**

**DRAWN BY: LT**

**CHECKED BY: PDH**

**PROJECT MGR: WSH**

**CLIENT: SBSI**

STEEL BUILDINGS AND STRUCTURES, INC.  
P.O. BOX 1287,  
MOUNT AIRY, NC 27030  
30'-0" x 20'-0" ENCLOSED STRUCTURE

**DATE: 12-11-20**

**SHT. 10**

**SCALE: NTS**

**DWG. NO: SK-3**

**JOB NO: 18068S/18156S  
18290S/20019S/20324S**

**REV: 9**

THIS DOCUMENT IS THE PROPERTY OF MOORE AND ASSOCIATES ENGINEERING AND CONSULTING. THE UNAUTHORIZED REPRODUCTION, COPYING, OR OTHERWISE USE OF THIS DOCUMENT IS STRICTLY PROHIBITED AND ANY INFRINGEMENT THEREUPON MAY BE SUBJECT TO LEGAL ACTION.

# BOW EAVE RAFTER END WALL AND SIDE WALL OPENINGS

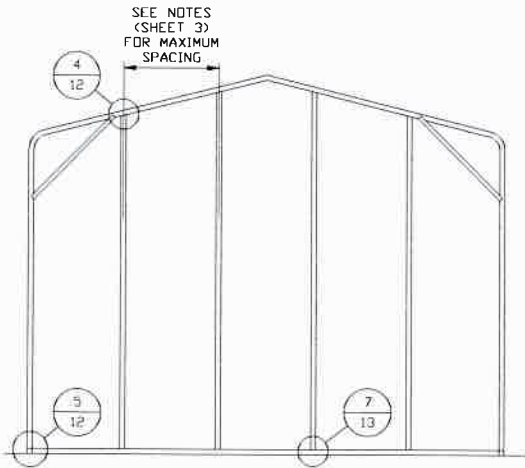

**TYPICAL BOX EAVE RAFTER  
END WALL FRAMING SECTION**

SCALE: NTS

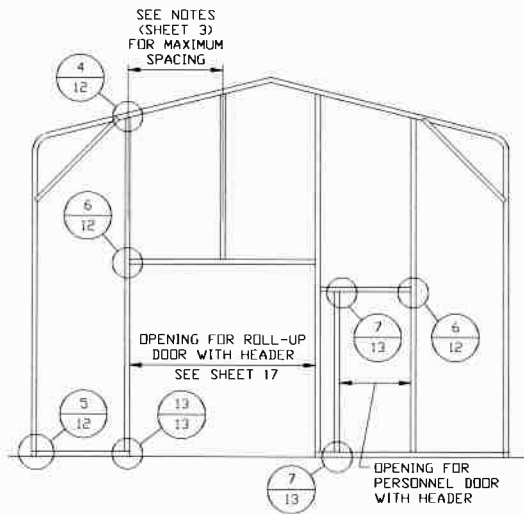

**TYPICAL BOX EAVE RAFTER END  
WALL OPENINGS FRAMING SECTION**

SCALE: NTS

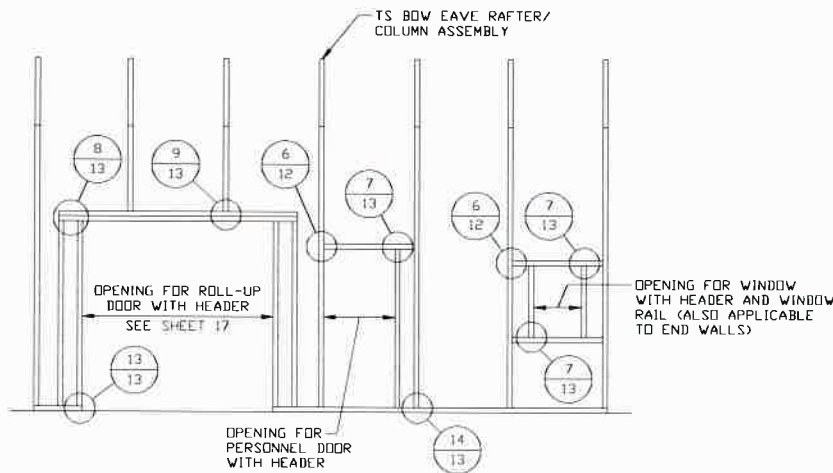

**TYPICAL BOX EAVE RAFTER  
SIDE WALL OPENINGS FRAMING SECTION**

SCALE: NTS

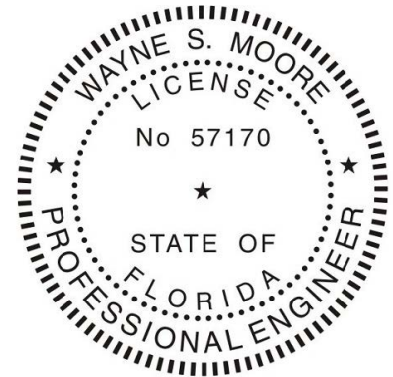

This item has been electronically signed and sealed by Wayne S. Moore, PE. using a Digital Signature and date.

Printed copies of this document are not considered signed and sealed and the signature must be verified on any electronic copies.

**MOORE AND ASSOCIATES  
ENGINEERING AND CONSULTING, INC.**

**DRAWN BY:** LT

**CHECKED BY:** PDH

**PROJECT MGR:** WSM

**CLIENT:** SBSI

STEEL BUILDINGS AND STRUCTURES, INC.  
P.O. BOX 1287,  
MOUNT AIRY, NC 27030  
30'-0" x 20'-0" ENCLOSED STRUCTURE

**DATE:** 12-11-20

**SHT.** 11

**SCALE:** NTS

**DWG. NO.:** SK-3

**JOB NO.:** 18068S/18156S  
18290S/20019S/20324S

**REV.:** 9

THIS DOCUMENT IS THE PROPERTY OF MOORE AND ASSOCIATES ENGINEERING AND CONSULTING. THE UNAUTHORIZED REPRODUCTION, COPYING, OR OTHERWISE USE OF THIS DOCUMENT IS STRICTLY PROHIBITED AND ANY INFRINGEMENT THEREUPON MAY BE SUBJECT TO LEGAL ACTION.

# CONNECTION DETAILS

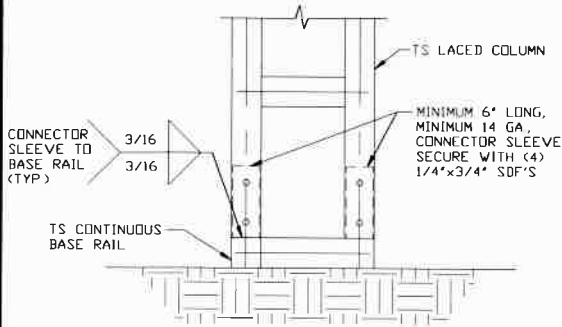

**3** POST/BASE RAIL CONNECTION DETAIL  
SCALE: NTS

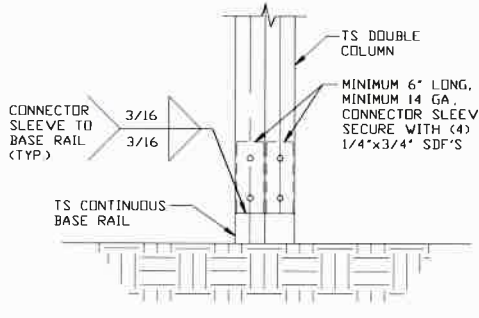

**3A** POST/BASE RAIL CONNECTION DETAIL  
SCALE: NTS

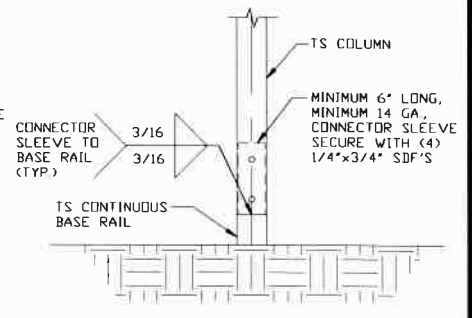

**3B** POST/BASE RAIL CONNECTION DETAIL  
SCALE: NTS

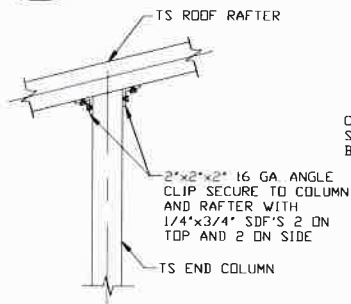

**4** END COLUMN/RAFTER CONNECTION DETAIL  
SCALE: NTS

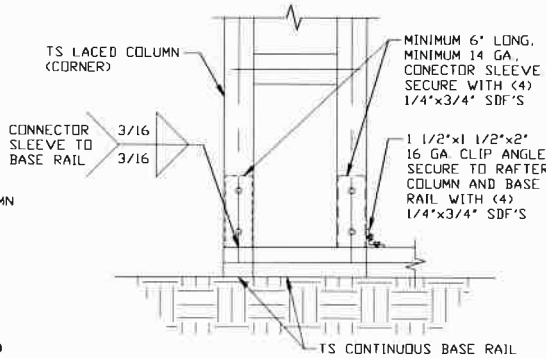

**5** END COLUMN/BASE RAIL CONNECTION DETAIL  
SCALE: NTS

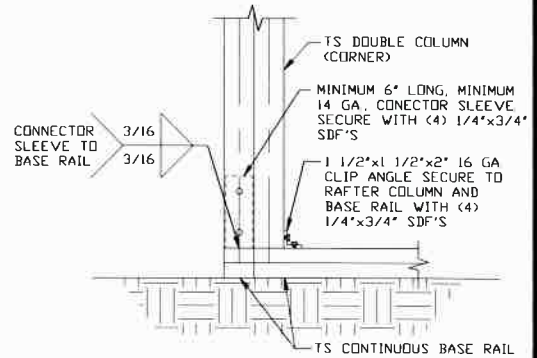

**5A** END COLUMN/BASE RAIL CONNECTION DETAIL  
SCALE: NTS

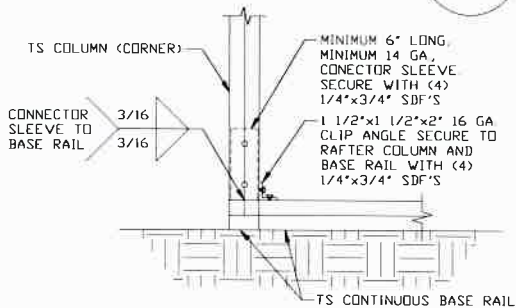

**5B** END COLUMN/BASE RAIL CONNECTION DETAIL  
SCALE: NTS

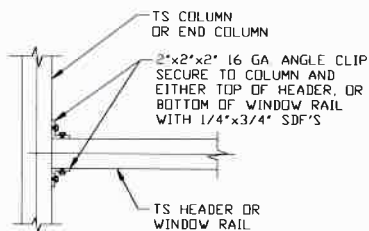

**6** COLUMN OR WINDOW RAIL/WALL GIRT TO POST CONNECTION DETAIL  
SCALE: NTS



This item has been electronically signed and sealed by Wayne S. Moore, PE. using a Digital Signature and date.

Printed copies of this document are not considered signed and sealed and the signature must be verified on any electronic copies.

**MOORE AND ASSOCIATES ENGINEERING AND CONSULTING, INC.**

**DRAWN BY: LT**

**CHECKED BY: PDH**

**PROJECT MGR: WSM**

**CLIENT: SBST**

STEEL BUILDINGS AND STRUCTURES, INC.  
P.O. BOX 1287,  
MOUNT AIRY, NC 27030  
30'-0" x 20'-0" ENCLOSED STRUCTURE

**DATE: 12-11-20**

**SHT. 12**

**SCALE: NTS**

**DWG. NO: SK-3**

**JOB NO: 18068S/18156S  
18290S/20019S/20324S**

**REV: 9**

THIS DOCUMENT IS THE PROPERTY OF MOORE AND ASSOCIATES ENGINEERING AND CONSULTING. THE UNAUTHORIZED REPRODUCTION, COPYING, OR OTHERWISE USE OF THIS DOCUMENT IS STRICTLY PROHIBITED AND ANY INFRINGEMENT THEREUPON MAY BE SUBJECT TO LEGAL ACTION.

# CONNECTION DETAILS

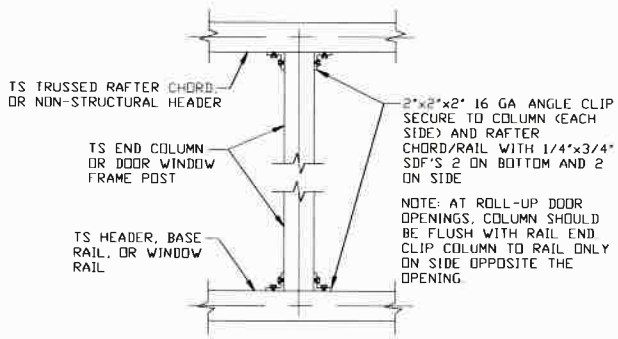

**7** COLUMN TO HEADER, BASE RAIL, OR WINDOW RAIL CONNECTION DETAIL  
SCALE: NTS

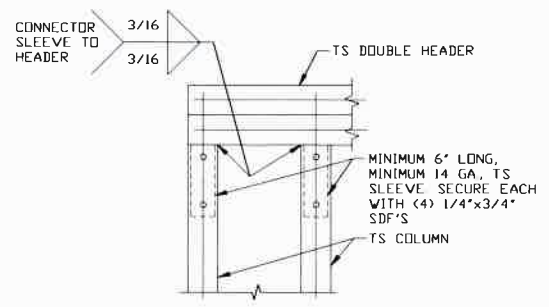

**8** DOUBLE HEADER/COLUMN CONNECTION DETAIL  
SCALE: NTS

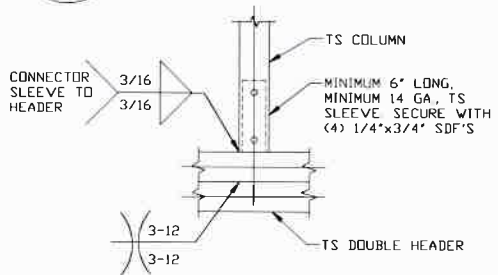

**9** COLUMN/DOUBLE HEADER CONNECTION DETAIL  
SCALE: NTS

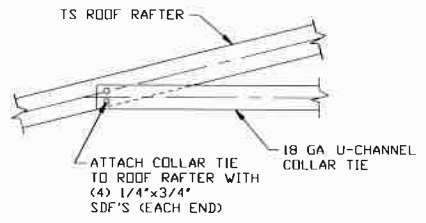

**10** COLLAR TIE CONNECTION DETAIL  
SCALE: NTS

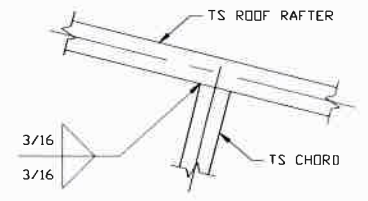

**11** RAFTER TO CHORD CONNECTION DETAIL  
SCALE: NTS

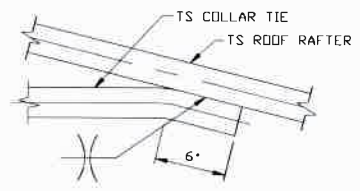

**12** COLLAR TIE CONNECTION DETAIL  
SCALE: NTS

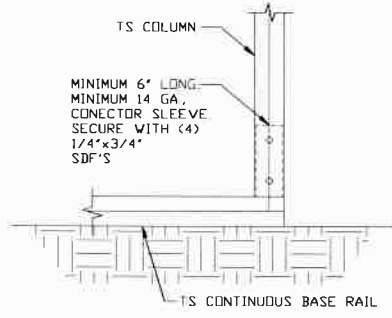

**13** COLUMN/BASE RAIL CONNECTION DETAIL  
SCALE: NTS

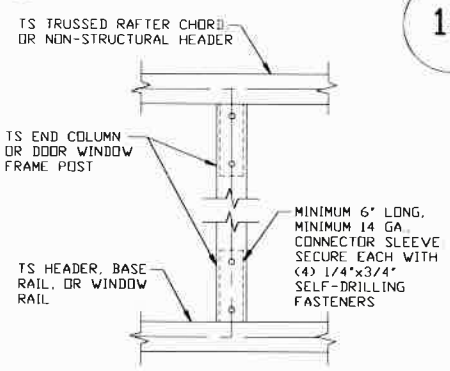

**14** COLUMN TO HEADER OR BASE RAIL CONNECTION DETAIL  
SCALE: NTS



This item has been electronically signed and sealed by Wayne S. Moore, PE. using a Digital Signature and date.

Printed copies of this document are not considered signed and sealed and the signature must be verified on any electronic copies.

<b>MOORE AND ASSOCIATES ENGINEERING AND CONSULTING, INC.</b>	DRAWN BY: LT	STEEL BUILDINGS AND STRUCTURES, INC. P.O. BOX 1287, MOUNT AIRY, NC 27030 30'-0"X20'-0" ENCLOSED STRUCTURE			
	CHECKED BY: PDH				
PROJECT MGR: WSM	DATE: 12-11-20	SCALE: NTS	JOB NO: 18068S/18156S 18290S/20019S/20324S		
CLIENT: SBST	SHT. 13	DWG. NO: SK-3	REV: 9		

THIS DOCUMENT IS THE PROPERTY OF MOORE AND ASSOCIATES ENGINEERING AND CONSULTING. THE UNAUTHORIZED REPRODUCTION, COPYING, OR OTHERWISE USE OF THIS DOCUMENT IS STRICTLY PROHIBITED AND ANY INFRINGEMENT THEREUPON MAY BE SUBJECT TO LEGAL ACTION.

# BOX EAVE RAFTER LEAN-TO OPTIONS

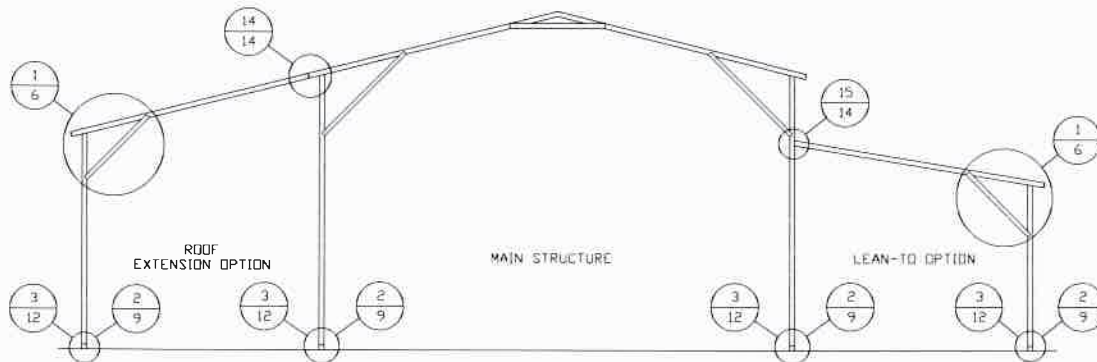

## TYPICAL BOX EAVE RAFTER LEAN-TO OPTIONS FRAMING SECTION (BOTH OPTIONS SHOWN)

SCALE: NTS

MAXIMUM WIDTH OF SINGLE TS ROOF EXTENSION LEAN-TO IS 12'-0"

MAXIMUM WIDTH OF DOUBLE TS ROOF EXTENSION LEAN-TO IS 16'-0"

MAXIMUM SINGLE COLUMN HEIGHT FOR MAIN BUILDING WITH ROOF EXTENSION LEAN-TO ATTACHED IS 8'-0"  
FOR COLUMN CONFIGURATIONS REFERENCE RAFTER COLUMN CONNECTION DETAILS.

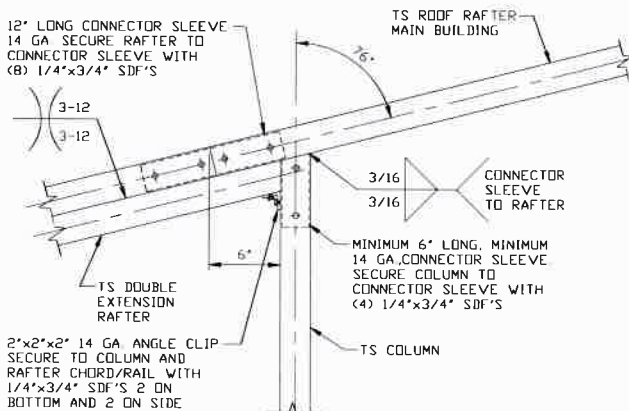

**14**  
**SIDE EXTENSION RAFTER/  
COLUMN DETAIL FOR RAFTER  
SPANS 12'-0" < TO < 16'-0"**  
SCALE: NTS

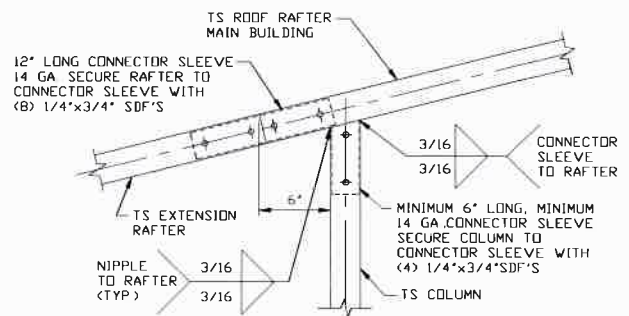

**14A**  
**SIDE EXTENSION RAFTER/  
COLUMN DETAIL FOR  
RAFTER SPANS ≤ 12'-0"**  
SCALE: NTS

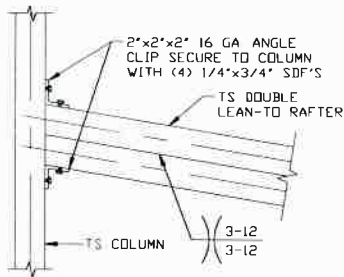

**15**  
**LEAN-TO RAFTER  
TO RAFTER POST  
CONNECTION DETAIL  
FOR WIDTHS  
12'-0" < TO < 16'-0"**  
SCALE: NTS

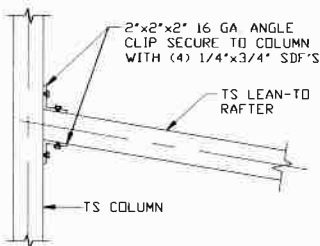

**15A**  
**LEAN-TO RAFTER  
TO RAFTER POST  
CONNECTION DETAIL  
FOR WIDTHS ≤ 12'-0"**  
SCALE: NTS

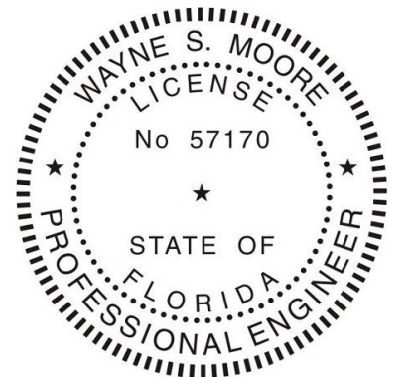

This item has been electronically signed and sealed by Wayne S. Moore, PE, using a Digital Signature and date.

Printed copies of this document are not considered signed and sealed and the signature must be verified on any electronic copies.

**MOORE AND ASSOCIATES  
ENGINEERING AND CONSULTING, INC.**

**DRAWN BY: LT**

**CHECKED BY: PDH**

**PROJECT MGR: WSM**

**CLIENT: SBSI**

STEEL BUILDINGS AND STRUCTURES, INC.  
P.O. BOX 1287,  
MOUNT AIRY, NC 27030  
30'-0" x 20'-0" ENCLOSED STRUCTURE

**DATE: 12-11-20**

**SHT. 14**

**SCALE: NTS**

**DWG. NO: SK-3**

**JOB NO: 18068S/18156S  
18290S/20019S/20324S**

**REV: 9**

THIS DOCUMENT IS THE PROPERTY OF MOORE AND ASSOCIATES ENGINEERING AND CONSULTING. THE UNAUTHORIZED REPRODUCTION, COPYING, OR OTHERWISE USE OF THIS DOCUMENT IS STRICTLY PROHIBITED AND ANY INFRINGEMENT THEREUPON MAY BE SUBJECT TO LEGAL ACTION.

# BOW EAVE RAFTER LEAN-TO OPTIONS

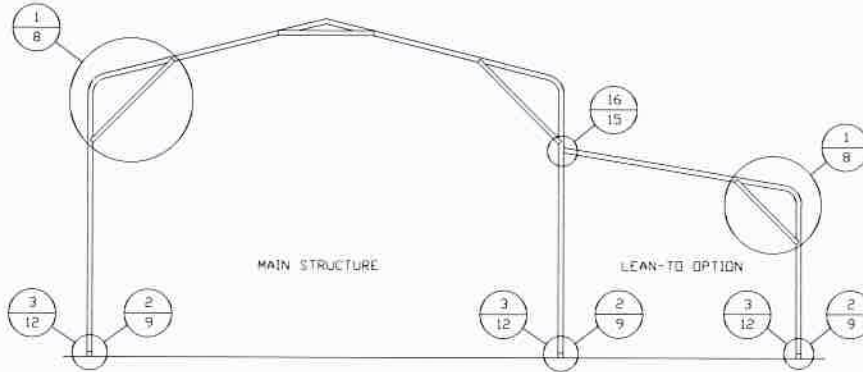

## TYPICAL BOW EAVE RAFTER LEAN-TO OPTIONS FRAMING SECTION

SCALE: NTS  
 MAXIMUM WIDTH OF SINGLE TS ROOF EXTENSION LEAN-TO IS 12'-0"  
 MAXIMUM WIDTH OF DOUBLE TS ROOF EXTENSION LEAN-TO IS 16'-0"  
 MAXIMUM SINGLE COLUMN HEIGHT FOR MAIN BUILDING WITH ROOF EXTENSION LEAN-TO ATTACHED IS 8'-0"  
 FOR COLUMN CONFIGURATIONS REFERENCE RAFTER COLUMN CONNECTION DETAILS.

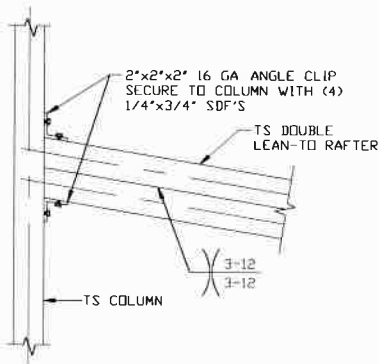

**LEAN-TO RAFTER TO  
 RAFTER POST  
 CONNECTION  
 DETAIL FOR WIDTHS  
 12'-0" < TO ≤ 16'-0"**

16

SCALE: NTS

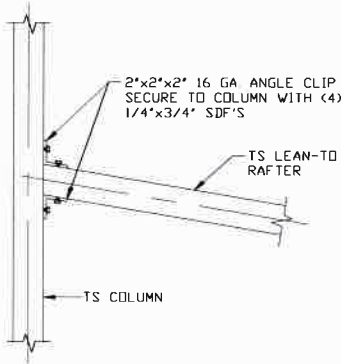

**LEAN-TO RAFTER  
 TO RAFTER POST  
 CONNECTION  
 DETAIL  
 FOR WIDTHS ≤ 12'-0"**

16A

SCALE: NTS

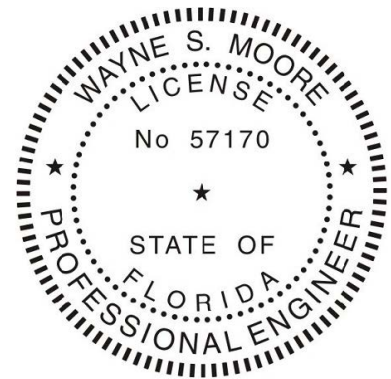

This item has been electronically signed and sealed by Wayne S. Moore, PE. using a Digital Signature and date.

Printed copies of this document are not considered signed and sealed and the signature must be verified on any electronic copies.

**MOORE AND ASSOCIATES  
 ENGINEERING AND CONSULTING, INC.**

**DRAWN BY: LT**

**CHECKED BY: PDH**

**PROJECT MGR: WSM**

**CLIENT: SBSI**

**STEEL BUILDINGS AND STRUCTURES, INC.,  
 P.O. BOX 1287,  
 MOUNT AIRY, NC 27030  
 30'-0"X20'-0" ENCLOSED STRUCTURE**

**DATE: 12-11-20**

**SHT. 15**

**SCALE: NTS**

**DWG. NO: SK-3**

**JOB NO: 18068S/18156S  
 18290S/20019S/20324S**

**REV: 9**

THIS DOCUMENT IS THE PROPERTY OF MOORE AND ASSOCIATES ENGINEERING AND CONSULTING. THE UNAUTHORIZED REPRODUCTION, COPYING, OR OTHERWISE USE OF THIS DOCUMENT IS STRICTLY PROHIBITED AND ANY INFRINGEMENT THEREUPON MAY BE SUBJECT TO LEGAL ACTION.

# BOX EAVE RAFTER VERTICAL ROOF/SIDING OPTION

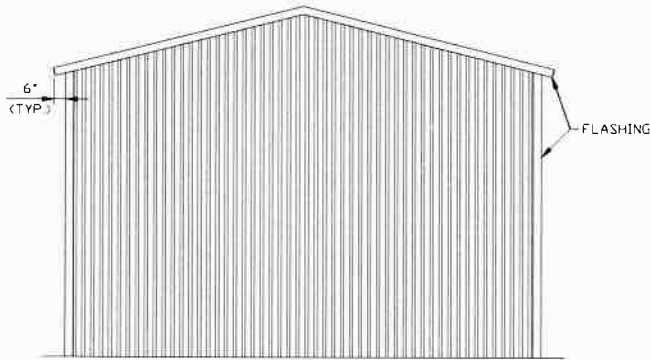

**TYPICAL END ELEVATION  
VERTICAL ROOF/SIDING**

SCALE: NTS

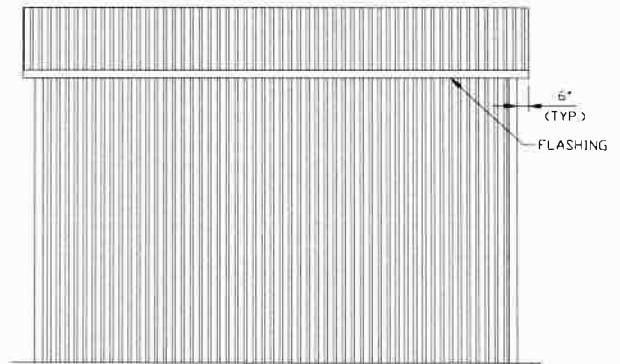

**TYPICAL SIDE ELEVATION  
VERTICAL ROOF/SIDING**

SCALE: NTS

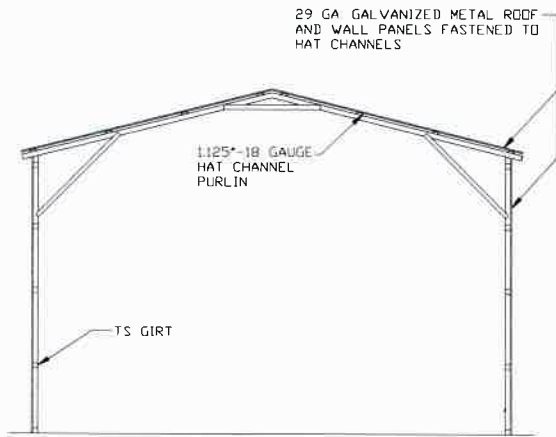

**TYPICAL SECTION  
VERTICAL ROOF/SIDING OPTION**

SCALE: NTS

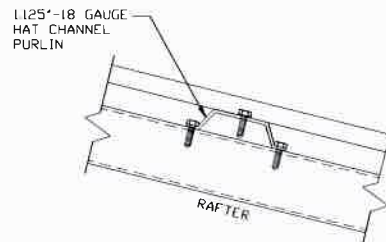

**PANEL ATTACHMENT**

(ALTERNATE FOR VERTICAL ROOF PANELS)  
SCALE: NTS

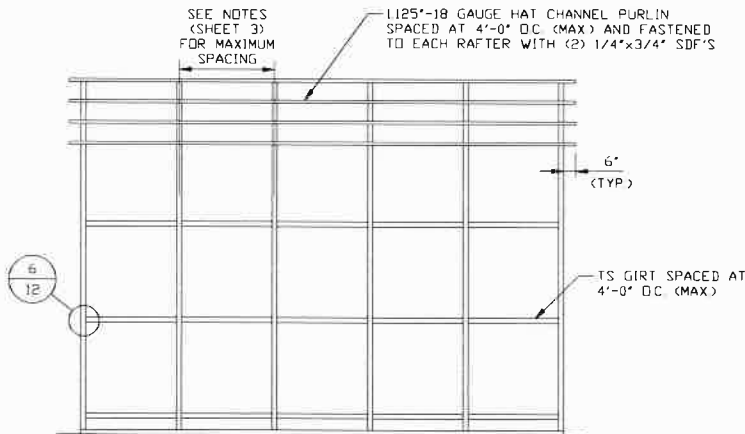

**TYPICAL FRAMING SECTION  
VERTICAL ROOF/SIDING OPTION**

SCALE: NTS

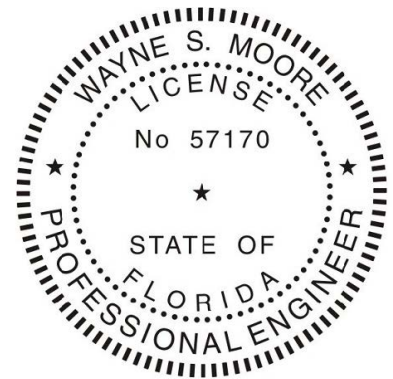

This item has been electronically signed and sealed by Wayne S. Moore, PE. using a Digital Signature and date.

Printed copies of this document are not considered signed and sealed and the signature must be verified on any electronic copies.

**MOORE AND ASSOCIATES  
ENGINEERING AND CONSULTING, INC.**

**DRAWN BY: LT**

**CHECKED BY: PDH**

**PROJECT MGR: WSM**

**CLIENT: SBSI**

STEEL BUILDINGS AND STRUCTURES, INC.  
P.O. BOX 1287,  
MOUNT AIRY, NC 27030  
30'-0"x20'-0" ENCLOSED STRUCTURE

**DATE: 12-11-20**

**SHT. 16**

**SCALE: NTS**

**DWG. NO: SK-3**

**JOB NO: 18068S/18156S  
18290S/20019S/20324S**

**REV: 9**

THIS DOCUMENT IS THE PROPERTY OF MOORE AND ASSOCIATES ENGINEERING AND CONSULTING. THE UNAUTHORIZED REPRODUCTION, COPYING, OR OTHERWISE USE OF THIS DOCUMENT IS STRICTLY PROHIBITED AND ANY INFRINGEMENT THEREUPON MAY BE SUBJECT TO LEGAL ACTION.

## SIDE WALL HEADER OPTIONS

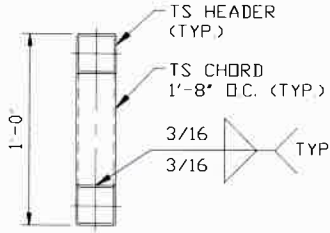

**LACED HEADER DETAIL FOR DOOR OPENINGS 12'-0" < LENGTH ≤ 20'-0"**  
SCALE: NTS

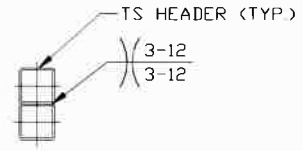

**DOUBLE HEADER DETAIL FOR DOOR OPENINGS 7'-0" < LENGTH ≤ 12'-0"**  
SCALE: NTS

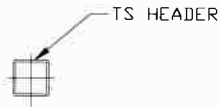

**SINGLE HEADER DETAIL FOR DOOR OPENINGS LENGTH ≤ 7'-0"**  
SCALE: NTS

## END WALL HEADER OPTIONS

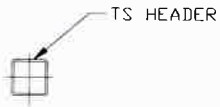

**SINGLE HEADER DETAIL FOR DOOR OPENINGS LENGTH ≤ 12'-0"**  
SCALE: NTS



This item has been electronically signed and sealed by Wayne S. Moore, PE. using a Digital Signature and date.

Printed copies of this document are not considered signed and sealed and the signature must be verified on any electronic copies.

**MOORE AND ASSOCIATES  
ENGINEERING AND CONSULTING, INC.**

**DRAWN BY: LT**

**CHECKED BY: PDH**

**PROJECT MGR: WSM**

**CLIENT: SBSI**

**STEEL BUILDINGS AND STRUCTURES, INC.**  
P.O. BOX 1287,  
MOUNT AIRY, NC 27030  
30'-0"x20'-0" ENCLOSED STRUCTURE

**DATE: 12-11-20**

**SHT. 17**

**SCALE: NTS**

**DWG. NO: SK-3**

**JOB NO: 18068S/18156S  
18290S/20019S/20324S**

**REV: 9**

THIS DOCUMENT IS THE PROPERTY OF MOORE AND ASSOCIATES ENGINEERING AND CONSULTING. THE UNAUTHORIZED REPRODUCTION, COPYING, OR OTHERWISE USE OF THIS DOCUMENT IS STRICTLY PROHIBITED AND ANY INFRINGEMENT THEREUPON MAY BE SUBJECT TO LEGAL ACTION.

# OPTIONAL BASE RAIL ON GRADE APPLICATION

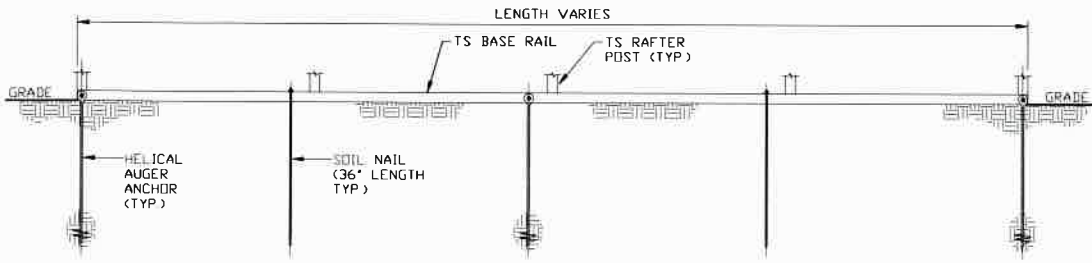

**SECTION 2**  
SCALE: NTS

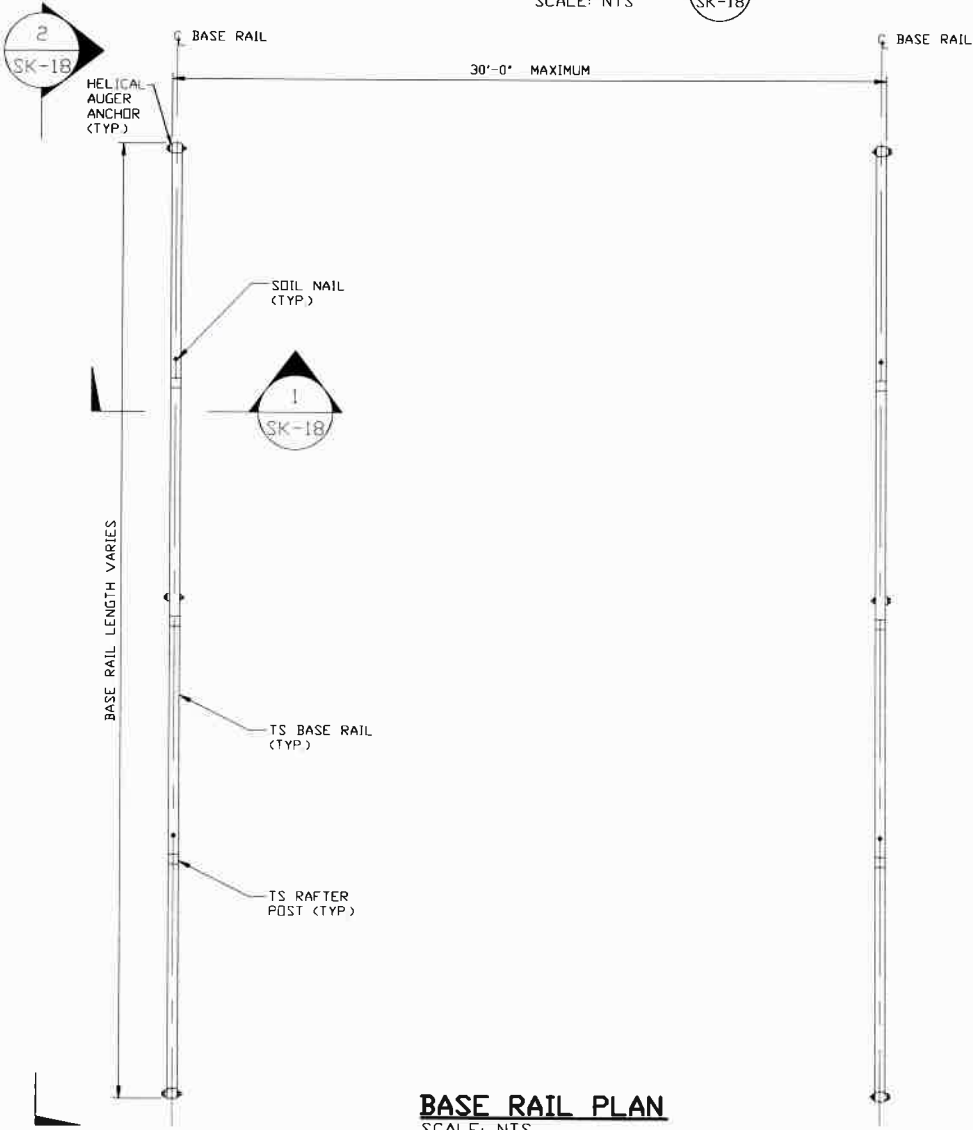

**BASE RAIL PLAN**  
SCALE: NTS

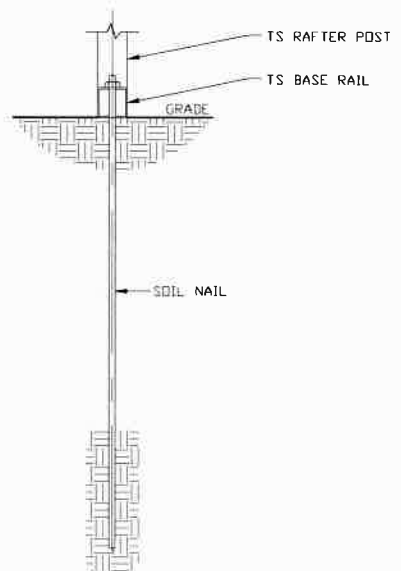

**SECTION 1**  
SCALE: NTS

HELIX ANCHOR	
SIDE LENGTH	MAXIMUM SPACING
VARIES	10'-0" (EVERY OTHER POST)

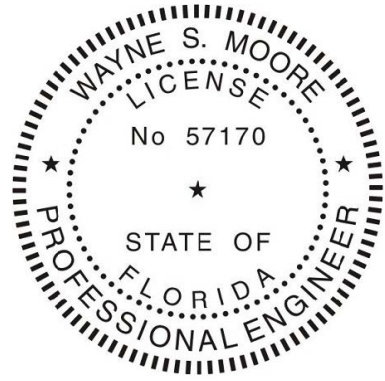

This item has been electronically signed and sealed by Wayne S. Moore, PE. using a Digital Signature and date.

Printed copies of this document are not considered signed and sealed and the signature must be verified on any electronic copies.

<b>MOORE AND ASSOCIATES ENGINEERING AND CONSULTING, INC.</b>	DRAWN BY: LT	STEEL BUILDINGS AND STRUCTURES, INC.		
	CHECKED BY: PDH	P.O. BOX 1287, MOUNT AIRY, NC 27030 30'-0" x 20'-0" ENCLOSED STRUCTURE		
THIS DOCUMENT IS THE PROPERTY OF MOORE AND ASSOCIATES ENGINEERING AND CONSULTING. THE UNAUTHORIZED REPRODUCTION, COPYING, OR OTHERWISE USE OF THIS DOCUMENT IS STRICTLY PROHIBITED AND ANY INFRINGEMENT THEREUPON MAY BE SUBJECT TO LEGAL ACTION.	PROJECT MGR: WSM	DATE: 12-11-20	SCALE: NTS	JOB NO: 18068S/18156S 18290S/20019S/20324S
	CLIENT: SBSI	SHT. 18	DWG. NO: SK-3	REV: 9

# OPTIONAL BASE RAIL ON TIMBER BEAM

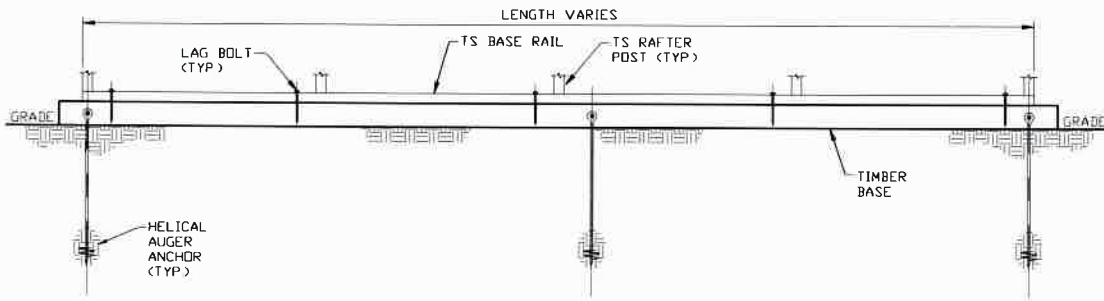

**SECTION 2**  
SCALE: NTS

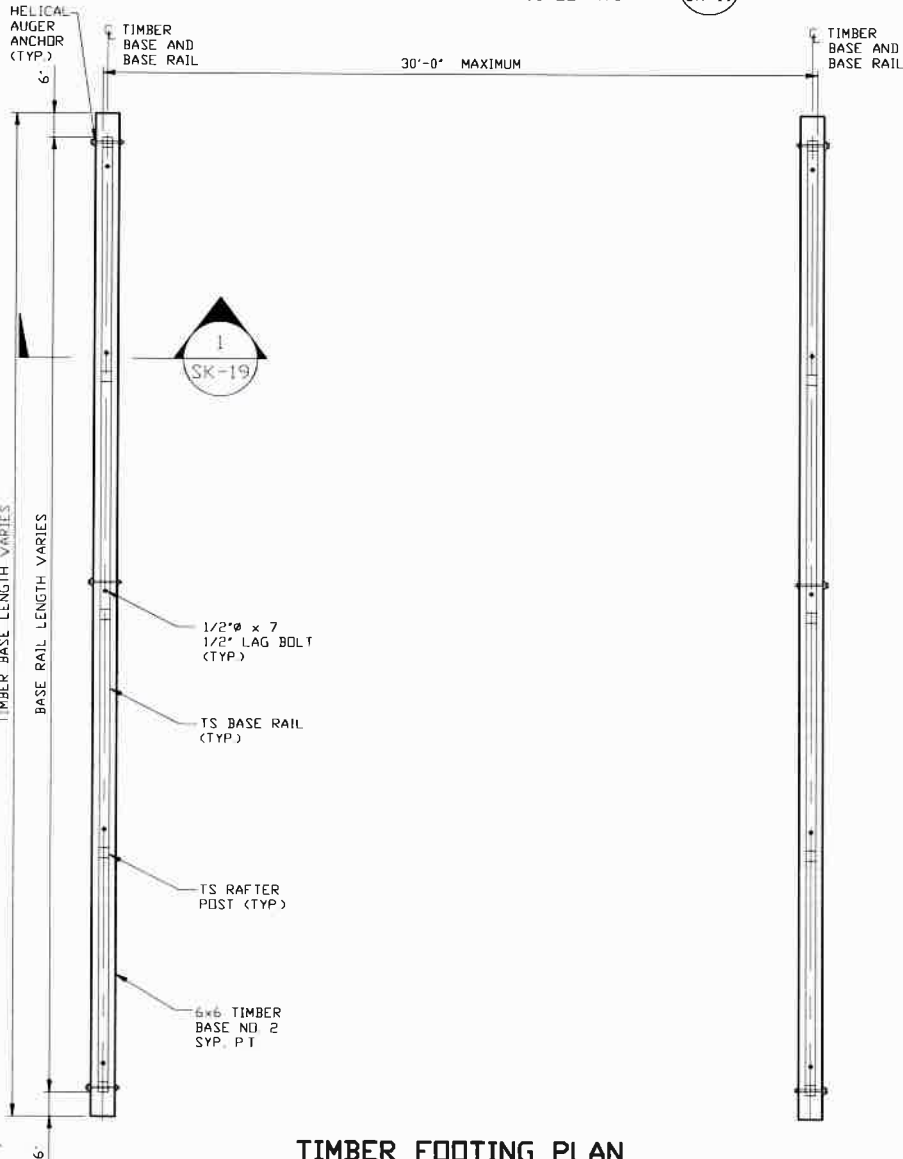

**TIMBER FOOTING PLAN**  
SCALE: NTS

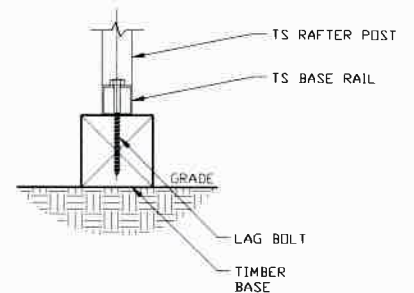

**SECTION 1**  
SCALE: NTS

HELIX ANCHOR	
SIDE LENGTH	MAXIMUM SPACING
VARIES	10'-0" (EVERY OTHER POST)

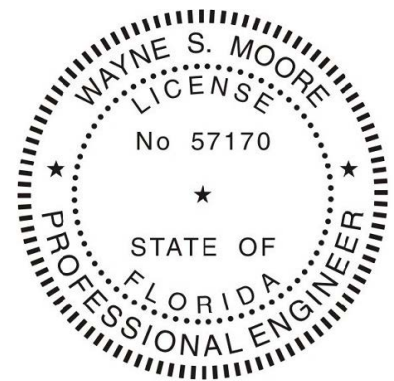

This item has been electronically signed and sealed by Wayne S. Moore, PE. using a Digital Signature and date.

Printed copies of this document are not considered signed and sealed and the signature must be verified on any electronic copies.

**MOORE AND ASSOCIATES  
ENGINEERING AND CONSULTING, INC.**

**DRAWN BY: LT**

**CHECKED BY: PDH**

**PROJECT MGR: WSH**

**CLIENT: S8SI**

STEEL BUILDINGS AND STRUCTURES, INC.  
P.O. BOX 1287,  
MOUNT AIRY, NC 27030  
30'-0"x20'-0" ENCLOSED STRUCTURE

**DATE: 12-11-20**

**SHT. 19**

**SCALE: NTS**

**DWG. NO: SK-3**

**JOB NO: 18068S/18156S  
18290S/20019S/20324S**

**REV: 9**

THIS DOCUMENT IS THE PROPERTY OF MOORE AND ASSOCIATES ENGINEERING AND CONSULTING. THE UNAUTHORIZED REPRODUCTION, COPYING, OR OTHERWISE USE OF THIS DOCUMENT IS STRICTLY PROHIBITED AND ANY INFRINGEMENT THEREUPON MAY BE SUBJECT TO LEGAL ACTION.

# OPTIONAL BASE RAIL ON TIMBER BEAM WITH SOIL NAIL

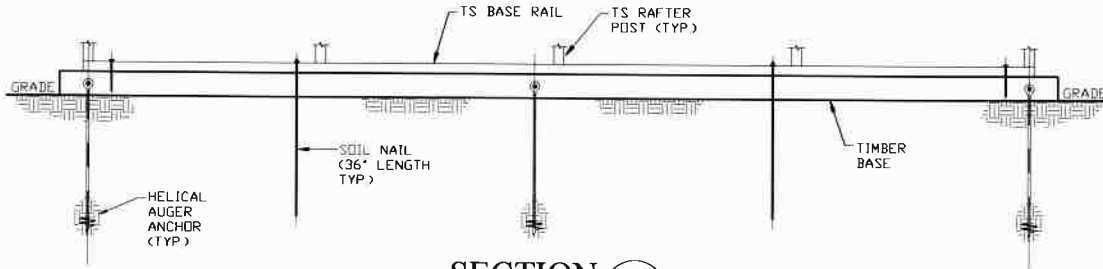

**SECTION 2**  
SCALE: NTS

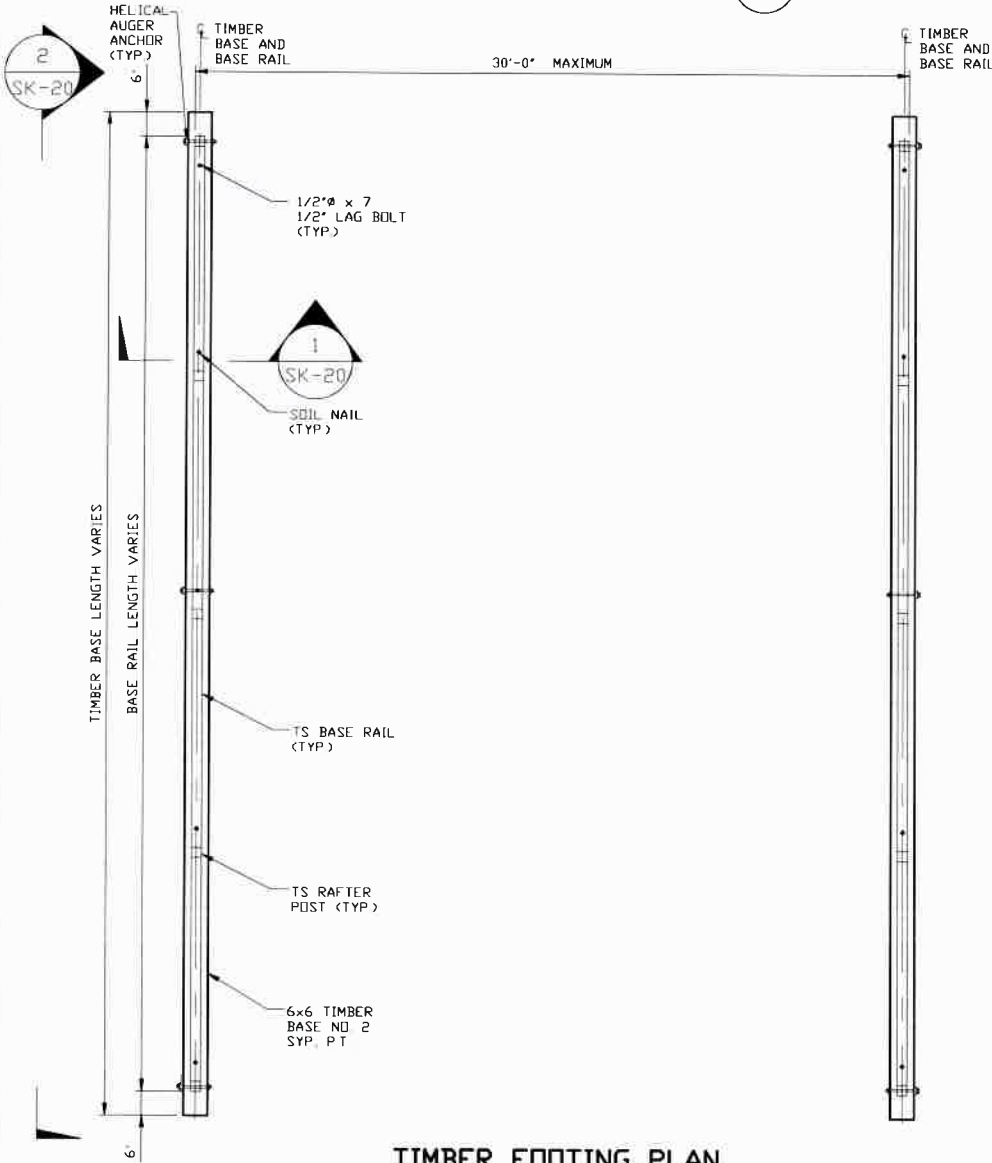

**TIMBER FOOTING PLAN**  
SCALE: NTS

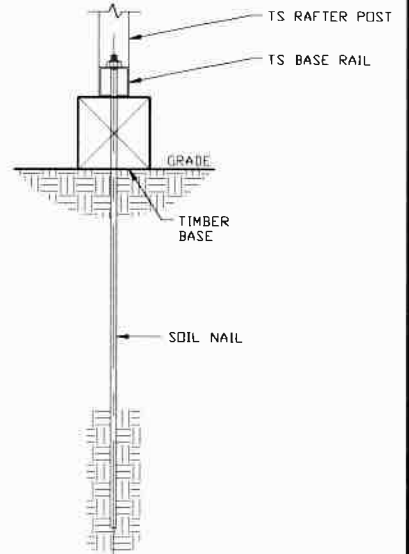

**SECTION 1**  
SCALE: NTS

HELIX ANCHOR	
SIDE LENGTH	MAXIMUM SPACING
VARIES	10'-0" (EVERY OTHER POST)



This item has been electronically signed and sealed by Wayne S. Moore, PE. using a Digital Signature and date.

Printed copies of this document are not considered signed and sealed and the signature must be verified on any electronic copies.

**MOORE AND ASSOCIATES  
ENGINEERING AND CONSULTING, INC.**

**DRAWN BY: LT**

**CHECKED BY: PDH**

**PROJECT MGR: WSM**

**CLIENT: SBSI**

**STEEL BUILDINGS AND STRUCTURES, INC.**  
P.O. BOX 1287,  
MOUNT AIRY, NC 27030  
30'-0"x20'-0" ENCLOSED STRUCTURE

**DATE: 12-11-20**

**SHT. 20**

**SCALE: NTS**

**DWG. NO: SK-3**

**JOB NO: 18068S/18156S  
18290S/20019S/20324S**

**REV: 9**

THIS DOCUMENT IS THE PROPERTY OF MOORE AND ASSOCIATES ENGINEERING AND CONSULTING, THE UNAUTHORIZED REPRODUCTION, COPYING, OR OTHERWISE USE OF THIS DOCUMENT IS STRICTLY PROHIBITED AND ANY INFRINGEMENT THEREUPON MAY BE SUBJECT TO LEGAL ACTION.

# OPTIONAL CONCRETE STRIP FOOTING

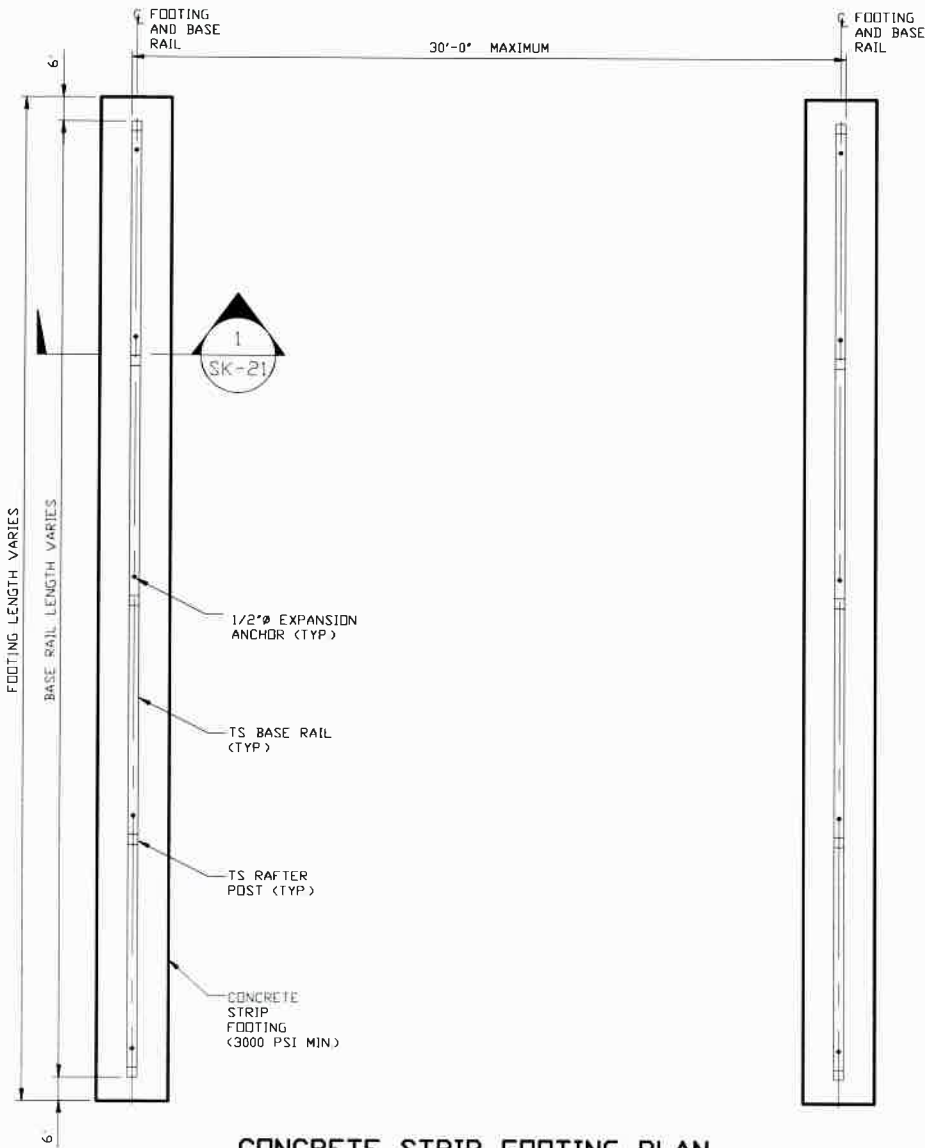

**CONCRETE STRIP FOOTING PLAN**  
SCALE: NTS

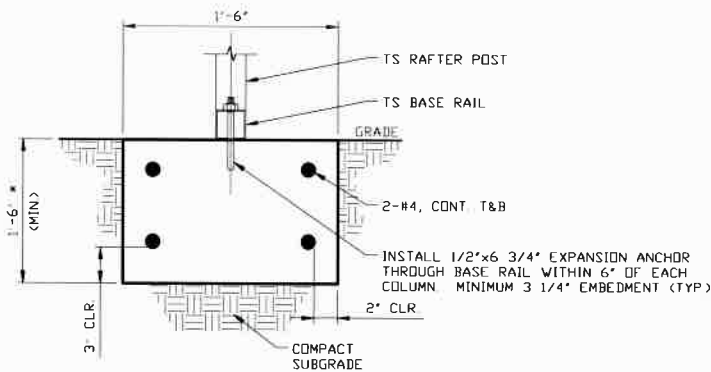

**SECTION 1**  
SCALE: NTS 1 SK-21

\* COORDINATE WITH LOCAL CODES/ORD



This item has been electronically signed and sealed by Wayne S. Moore, PE. using a Digital Signature and date.

Printed copies of this document are not considered signed and sealed and the signature must be verified on any electronic copies.

**MOORE AND ASSOCIATES  
ENGINEERING AND CONSULTING, INC.**

**DRAWN BY: LT**

**CHECKED BY: PDH**

**PROJECT MGR: WSM**

**CLIENT: SBSI**

STEEL BUILDINGS AND STRUCTURES, INC.  
P.O. BOX 1287,  
MOUNT AIRY, NC 27030  
30'-0" x 20'-0" ENCLOSED STRUCTURE

**DATE: 12-11-20**

**SHT. 21**

**SCALE: NTS**

**DWG. NO: SK-3**

**JOB NO: 18068S/18156S  
18290S/20019S/20324S**

**REV: 9**

THIS DOCUMENT IS THE PROPERTY OF MOORE AND ASSOCIATES ENGINEERING AND CONSULTING, THE UNAUTHORIZED REPRODUCTION, COPYING, OR OTHERWISE USE OF THIS DOCUMENT IS STRICTLY PROHIBITED AND ANY INFRINGEMENT THEREUPON MAY BE SUBJECT TO LEGAL ACTION.