

COLUMBIA COUNTY Property Appraiser

Parcel 12-4S-15-00344-006

Owners

LORD KERRY F
LORD ASHLEY V
LORD KERRY A
458 SW DAVENPORT GLN
LAKE CITY, FL 32024

Parcel Summary

Location	458 SW DAVENPORT GLN
Use Code	0200: MOBILE HOME
Tax District	3: COUNTY
Acreage	4.0100
Section	12
Township	4S
Range	15
Subdivision	GODBLD AC
Exemptions	01: PARTIAL HOMESTEAD (196.031a&b) (100%)

Legal Description

LOT 6 GODBOLD ACRES S/D.
ORB 671-277, TEN IN COMM
860-879, PROB #99-114-CP
885-1284 THRU 1304, 944-344,

Working Values

	2026
Total Building	\$28,931
Total Extra Features	\$7,000
Total Market Land	\$50,000
Total Ag Land	\$0



//

	2026
Total Market	\$85,931
Total Assessed	\$41,874
Total Exempt	\$22,924
Total Taxable	\$18,950
SOH Diff	\$44,057

Value History

	2025	2024	2023	2022	2021	2020
Total Building	\$28,931	\$23,206	\$21,093	\$16,456	\$15,316	\$11,572
Total Extra Features	\$7,000	\$7,000	\$7,000	\$3,250	\$0	\$0
Total Market Land	\$50,000	\$40,000	\$40,000	\$26,000	\$20,850	\$20,838
Total Ag Land	\$0	\$0	\$0	\$0	\$0	\$0
Total Market	\$85,931	\$70,206	\$68,093	\$45,706	\$36,166	\$32,410
Total Assessed	\$39,548	\$37,353	\$35,297	\$33,390	\$31,617	\$30,273
Total Exempt	\$22,321	\$21,692	\$21,060	\$20,447	\$19,851	\$19,577
Total Taxable	\$17,227	\$15,661	\$14,237	\$12,943	\$11,766	\$10,696
SOH Diff	\$46,383	\$32,853	\$32,796	\$12,316	\$4,549	\$2,137

Document/Transfer/Sales History

Instrument / Official Record	Date	Q/U	Reason	Type	V/I	Sale Price	Ownership
<u>WD</u> 0944/0344	2002-01-07	<u>Q</u>	<u>06</u>	WARRANTY DEED	Improved	\$100	Grantor: PATRICIA MARIE FORD Grantee: KERRY J LORD
<u>AD</u> 0671/0277	1988-01-23	<u>Q</u>			Vacant	\$12,100	Grantor: BULLARD - DEAS Grantee: LORD KERRY &

Buildings

Building # 1, Section # 1, 11572, MOBILE HOME

Type	Models	Heated Sq Ft	Repl Cost New	YrBlt	Year Eff	Gross Area	Other % Dpr	Normal % Dpr	% Cond	Value
<u>0800</u>	<u>02</u>	1392	\$72,328	1979	1979	1,616	0.00%	60.00%	40.00%	\$28,931

Structural Elements

Type	Description	Code	Details
EW	Exterior Wall	03	BELOW AVG.

Sub Areas

Type	Gross Area	Percent of Base	Adjusted Area
<u>BAS</u>	1,392	100%	1,392

Type	Description	Code	Details
RS	Roof Structure	03	GABLE/HIP
RC	Roof Cover	01	MINIMUM
IW	Interior Wall	04	PLYWOOD
IF	Interior Flooring	08	SHT VINYL
IF	Interior Flooring	14	CARPET
AC	Air Conditioning	03	CENTRAL
HT	Heating Type	04	AIR DUCTED
BDR	Bedrooms	3.00	
BTH	Bathrooms	2.00	
STR	Stories	1.	1.
AR	Architectural Type	01	CONV
COND	Condition Adjustment	03	03
KTCH	Kitchen Adjustment	01	01

Type	Gross Area	Percent of Base	Adjusted Area
<u>UOP</u>	64	25%	16
<u>UOP</u>	160	25%	40

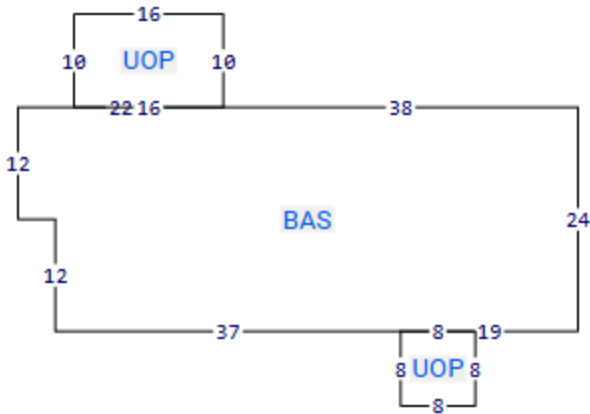

Extra Features

Code	Description	Length	Width	Units	Unit Price	AYB	% Good Condition	Final Value
9945	Well/Sept			1.00	\$7,000.00		100%	\$7,000

Land Lines

Code	Description	Zone	Front	Depth	Units	Rate/Unit	Acreage	Total Adj	Value
0200	MBL HM	<u>A-1</u>	.00	.00	1.00	\$50,000.00/ <u>LT</u>	4.01	1.00	\$50,000

Personal Property

None

Permits

None

TRIM Notices

2025

2024

2023

Disclaimer

All parcel data on this page is for use by the Columbia County Assessor for assessment purposes only. The summary data on this page may not be a complete representation of the parcel or of the improvements thereon. Building information, including unit counts and number of permitted units, should be verified with the appropriate building and planning agencies. Zoning information should be verified with the appropriate planning agency. All parcels are reappraised each year. This is a true and accurate copy of the records of the Columbia County Assessor's Office as of March 11, 2026.

Copyright © 2022 Columbia County. All rights reserved.
