

09/10/2025  
 COA#0-278  
 Florida Certificate of Product Approval #FL1999

This item has been digitally signed by Fernando Vinas on the date adjacent to the seal.

Printed copies of this document are not considered signed and sealed and the signature must be verified on any electronic copies.

Site Information:	Page 1:
Customer: W. B. Howland Company, Inc.	Job Number: 25-3021
Job Description: JUDY MCHUGH	
Address:	

Job Engineering Criteria:	
Design Code: FBC 8th Ed. 2023 Res.	IntelliVIEW Version: 24.02.00D JRef #: 1Yd92150003
Wind Standard: ASCE 7-22      Wind Speed (mph): 130	Design Loading (psf): 40.00
Building Type: Closed	

This package contains general notes pages, 44 truss drawing(s) and 1 detail(s).

Item	Drawing Number	Truss
1	252.25.1345.38430	A01
3	252.25.1345.31837	A03
5	252.25.1345.27073	B01
7	252.25.1345.21950	B03
9	252.25.1345.17673	B05
11	252.25.1345.13763	B07
13	252.25.1345.09547	B09
15	252.25.1345.05170	B11
17	252.25.1345.00813	B13
19	252.25.1344.56533	B15
21	252.25.1344.52647	B17
23	252.25.1344.49037	B19
25	252.25.1344.44757	B21
27	252.25.1344.33513	C01
29	252.25.1344.28967	C03
31	252.25.1344.25230	D02
33	252.25.1344.20000	HJ02
35	252.25.1344.09223	HJ04
37	252.25.1344.05957	J02
39	252.25.1344.02817	J04
41	252.25.1343.58420	J06
43	252.25.1343.54537	J08
45	BRCLBSUB0119	

Item	Drawing Number	Truss
2	252.25.1345.34640	A02
4	252.25.1345.29580	A04
6	252.25.1345.24070	B02
8	252.25.1345.19647	B04
10	252.25.1345.15753	B06
12	252.25.1345.11810	B08
14	252.25.1345.07273	B10
16	252.25.1345.02733	B12
18	252.25.1344.58663	B14
20	252.25.1344.54343	B16
22	252.25.1344.50903	B18
24	252.25.1344.46930	B20
26	252.25.1344.42333	B22
28	252.25.1344.30983	C02
30	252.25.1344.27200	D01
32	252.25.1344.22480	HJ01
34	252.25.1344.11237	HJ03
36	252.25.1344.07320	J01
38	252.25.1344.04447	J03
40	252.25.1343.59963	J05
42	252.25.1343.56797	J07
44	252.25.1343.51300	J09

## **General Notes**

### **Truss Design Engineer Scope of Work, Design Assumptions and Design Responsibilities:**

The design responsibilities assumed in the preparation of these design drawings are those specified in ANSI/TPI 1, Chapter 2; and the National Design Standard for Metal Plate Connected Wood Truss Construction, by the Truss Plate Institute. The truss component designs conform to the applicable provisions of ANSI/TPI 1 and NDS, the National Design Specification for Wood Construction by AWC. The truss component designs are based on the specified loading and dimension information furnished by others to the Truss Design Engineer. The Truss Design Engineer has no duty to independently verify the accuracy or completeness of the information provided by others and may rely on that information without liability. The responsibility for verification of that information remains with others neither employed nor controlled by the Truss Design Engineer. The Truss Design Engineer's seal and signature on the attached drawings, or cover page listing these drawings, indicates acceptance of professional engineering responsibility solely for the truss component designs and not for the technical information furnished by others which technical information and consequences thereof remain their sole responsibility.

The suitability and use of these drawings for any particular structure is the responsibility of the Building Designer in accordance with ANSI/TPI 1 Chapter 2. The Building Designer is responsible for determining that the dimensions and loads for each truss component match those required by the plans and by the actual use of the individual component, and for ascertaining that the loads shown on the drawings meet or exceed applicable building code requirements and any additional factors required in the particular application. Truss components using metal connector plates with integral teeth shall not be placed in environments that will cause the moisture content of the wood in which plates are embedded to exceed 19% and/or cause corrosion of connector plates and other metal fasteners.

The Truss Design Engineer shall not be responsible for items beyond the specific scope of the agreed contracted work set forth herein, including but not limited to: verifying the dimensions of the truss component, calculation of any of the truss component design loads, inspection of the truss components before or after installation, the design of temporary or permanent bracing and their attachment required in the roof and/or floor systems, the design of diaphragms or shear walls, the design of load transfer connections to and from diaphragms and shear walls, the design of load transfer to the foundation, the design of connections for truss components to their bearing supports, the design of the bearing supports, installation of the truss components, observation of the truss component installation process, review of truss assembly procedures, sequencing of the truss component installation, construction means and methods, site and/or worker safety in the installation of the truss components and/or its connections.

This document may be a high-quality facsimile of the original engineering document which is a digitally signed electronic file with third party authentication. A wet or embossed seal copy of this engineering document is available upon request.

### **Temporary Lateral Restraint and Bracing:**

Temporary lateral restraint and diagonal bracing shall be installed according to the provisions of BCSI chapters B1, B2, B7 and/or B10 (Building Component Safety Information, by TPI and SBCA), or as specified by the Building Designer or other Registered Design Professional. The required locations for lateral restraint and/or bracing depicted on these drawings are only for the permanent lateral support of the truss members to reduce buckling lengths, and do not apply to and may not be relied upon for the temporary stability of the truss components during their installation.

### **Permanent Lateral Restraint and Bracing:**

The required locations for lateral restraint or bracing depicted on these drawings are for the permanent lateral support of the truss members to reduce buckling lengths. Permanent lateral support shall be installed according to the provisions of BCSI chapters B3, B7 and/or B10, or as specified by the Building Designer or other Registered Design Professional. These drawings do not depict or specify installation/erection bracing, wind bracing, portal bracing or similar building stability bracing which are parts of the overall building design to be specified, designed, and detailed by the Building Designer.

### **Connector Plate Information:**

Alpine connector plates are made of ASTM A653 or ASTM A1063 galvanized steel with the following designations, gauges and grades: W=Wave, 20ga, grade 40; H=High Strength, 20ga, grade 60; S=Super Strength, 18ga, grade 60. Information on model code compliance is contained in the ICC Evaluation Service report ESR-1118, available on-line at [www.icc-es.org](http://www.icc-es.org).

### **Bearing Information:**

The bearing area factor,  $C_b$ , is considered for the allowable capacity of solid sawn wood bearings supporting trusses that are located a minimum of 3" from the end of the lumber piece.

## **General Notes** (continued)

### **Coated Lumber:**

Coated lumber must be properly re-dried and maintained below 19% or less moisture level through all stages of construction and usage. Coated lumber has no adjustments to lumber properties. Coated lumber may be more brittle than uncoated lumber. Special handling care must be taken to prevent breakage during all handling activities. Refer to manufacturer literature, specifications, and code evaluation reports for restrictions, details, and requirements.

### **Fire Retardant Treated Lumber:**

Fire retardant treated lumber must be properly re-dried and maintained below 19% or less moisture level through all stages of construction and usage. Fire retardant treated lumber may be more brittle than untreated lumber. Special handling care must be taken to prevent breakage during all handling activities.

### **Key to Terms:**

Information provided on drawings reflects a summary of the pertinent information required for the truss design. Detailed information on load cases, reactions, member lengths, forces and members requiring permanent lateral support may be found in calculation sheets available upon written request.

BCDL = Bottom Chord standard design Dead Load in pounds per square foot.

BCLL = Bottom Chord standard design Live Load in pounds per square foot.

C = Coated lumber.

C-AT = AtTEK coated lumber.

C-FX = FX Lumber Guard coated lumber.

C-TE = TechWood 4400 coated lumber.

CL = Certified lumber.

Des Ld = total of TCLL, TCDL, BCLL and BCDL Design Load in pounds per square foot.

FRT = Fire Retardant Treated lumber.

FRT-BF = Boraflame Fire Retardant Treated lumber

FRT-DB = D-Blaze Fire Retardant Treated lumber.

FRT-DC = Dricon Fire Retardant Treated lumber.

FRT-FP = FirePRO Fire Retardant Treated lumber.

FRT-FL = FlamePRO Fire Retardant Treated lumber.

FRT-FT = FlameTech Fire Retardant Treated lumber.

FRT-ON = OnWood Fire Retardant Treated lumber.

FRT-PG = PYRO-GUARD Fire Retardant Treated lumber.

FRT-PR = ProWood Fire Retardant Treated lumber.

g = green lumber.

HORZ(LL) = maximum Horizontal panel point deflection due to Live Load, in inches.

HORZ(TL) = maximum Horizontal panel point long term deflection in inches, due to Total Load, including creep adjustment.

HPL = additional Horizontal Load added to a truss Piece in pounds per linear foot or pounds.

Ic = Incised lumber.

FJ = Finger Jointed lumber.

L/# = user specified divisor for limiting span/deflection ratio for evaluation of actual L/defl value.

L/defl = ratio of Length between bearings, in inches, divided by the vertical Deflection due to creep, in inches, at the referenced panel point. Reported as 999 if greater than or equal to 999.

Loc = Location, starting location of left end of bearing or panel point (joint) location of deflection.

Max BC CSI = Maximum bending and axial Combined Stress Index for Bottom Chords for all load cases.

Max TC CSI = Maximum bending and axial Combined Stress Index for Top Chords for all load cases.

Max Web CSI = Maximum bending and axial Combined Stress Index for Webs for all load cases.

NCBCLL = Non-Concurrent Bottom Chord design Live Load in pounds per square foot.

PL = additional Load applied at a user specified angle on a truss Piece in pounds per linear foot or pounds.

PLB = additional vertical load added to a Bottom chord Piece of a truss in pounds per linear foot or pounds

PLT = additional vertical load added to a Top chord Piece of a truss in pounds per linear foot or pounds.

PP = Panel Point.

R = maximum downward design Reaction, in pounds, from all specified gravity load cases, at the indicated location (Loc).

-R = maximum upward design Reaction, in pounds, from all specified gravity load cases, at the identified location (Loc).

Rh = maximum horizontal design Reaction in either direction, in pounds, from all specified gravity load cases, at the indicated location (Loc).

RL = maximum horizontal design Reaction in either direction, in pounds, from all specified non-gravity (wind or seismic) load cases, at the indicated location (Loc).

## **General Notes** (continued)

### **Key to Terms** (continued):

Rw = maximum downward design Reaction, in pounds, from all specified non-gravity (wind or seismic) load cases, at the identified location (Loc).

TCDL = Top Chord standard design Dead Load in pounds per square foot.

TCLL = Top Chord standard design Live Load in pounds per square foot.

U = maximum Upward design reaction, in pounds, from all specified non-gravity (wind or seismic) load cases, at the indicated location (Loc).

VERT(CL) = maximum Vertical panel point deflection in inches due to Live Load and Creep Component of Dead Load in inches.

VERT(CTL) = maximum Vertical panel point deflection ratios due to Live Load and Creep Component of Dead Load, and maximum long term Vertical panel point deflection in inches due to Total load, including creep adjustment.

VERT(LL) = maximum Vertical panel point deflection in inches due to Live Load.

VERT(TL) = maximum Vertical panel point long term deflection in inches due to Total load, including creep adjustment.

W = Width of non-hanger bearing, in inches.

Refer to ASCE-7 for Wind and Seismic abbreviations.

Uppercase Acronyms not explained above are as defined in TPI 1.

### **References:**

1. AWC: American Wood Council; 222 Catoclin Circle SE, Suite 201; Leesburg, VA 20175; [www.awc.org](http://www.awc.org).
2. ICC: International Code Council; [www.iccsafe.org](http://www.iccsafe.org).
3. Alpine, a division of ITW Building Components Group Inc.: 155 Harlem Ave, North Building, 4th Floor, Glenview, IL 60025; [www.alpineitw.com](http://www.alpineitw.com).
4. TPI: Truss Plate Institute, 2670 Crain Highway, Suite 203, Waldorf, MD 20601; [www.tpinst.org](http://www.tpinst.org).
5. SBCA: Wood Truss Council of America, 6300 Enterprise Lane, Madison, WI 53719; [www.sbcacomponents.com](http://www.sbcacomponents.com)

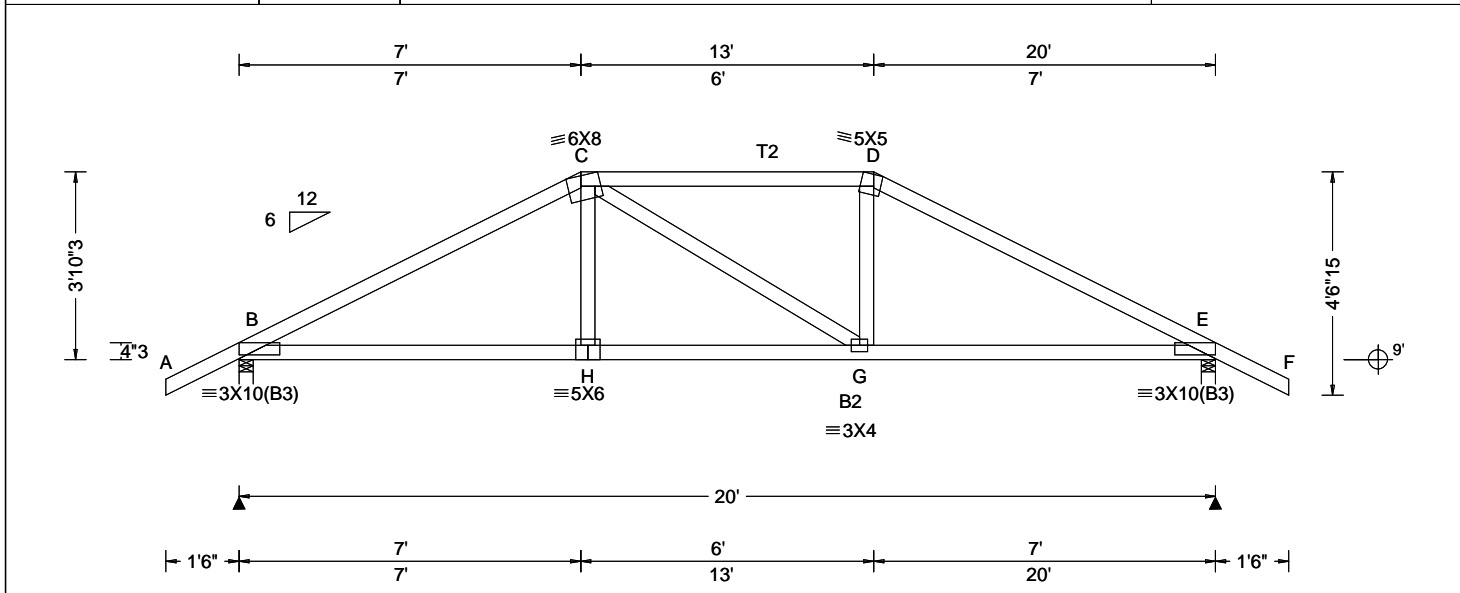

<b>Loading Criteria (psf)</b> TCLL: 20.00 TCDL: 10.00 BCLL: 0.00 BCDL: 10.00 Des Ld: 40.00 NCBCLL: 10.00 Soffit: 2.00 Load Duration: 1.25 Spacing: 24.0 "	<b>Wind Criteria</b> Wind Std: ASCE 7-22 Speed: 130 mph Enclosure: Closed Risk Category: II EXP: C Kzt: NA Mean Height: 15.00 ft TCDL: 4.2 psf BCDL: 3.0 psf MWFRS Parallel Dist: 0 to h/2 C&C Dist a: 3.00 ft Loc. from endwall: not in 4.50 ft GCp1: 0.18 Wind Duration: 1.60	<b>Snow Criteria (Pg,Pf in PSF)</b> Pg: NA Ct: NA CAT: NA Pf: NA Ce: NA Lu: NA Cs: NA Snow Duration: NA Building Code: FBC 8th Ed. 2023 Res. TPI Std: 2014 Rep Fac: Varies by Ld Case FT/RT:20(0)/10(0) Plate Type(s): WAVE	<b>Defl/CSI Criteria</b> PP Deflection in loc L/defl L/# VERT(LL): 0.111 H 999 240 VERT(CL): 0.223 H 999 180 HORZ(LL): 0.043 E - - HORZ(TL): 0.086 E - - Creep Factor: 2.0 Max TC CSI: 0.707 Max BC CSI: 0.996 Max Web CSI: 0.270 VIEW Ver: 24.02.00D.0114.10	<b>▲ Maximum Reactions (lbs)</b> <table border="1"> <thead> <tr> <th colspan="3">Gravity</th> <th colspan="3">Non-Gravity</th> </tr> <tr> <th>Loc</th> <th>R+</th> <th>/R-</th> <th>/Rh</th> <th>/Rw</th> <th>/U</th> <th>/RL</th> </tr> </thead> <tbody> <tr> <td>B</td> <td>2054</td> <td>-/-</td> <td>-/-</td> <td>-/-</td> <td>/556</td> <td>-/-</td> </tr> <tr> <td>E</td> <td>2054</td> <td>-/-</td> <td>-/-</td> <td>-/-</td> <td>/556</td> <td>-/-</td> </tr> </tbody> </table> <p>Wind reactions based on MWFRS            B Brg Wid = 3.5 Min Req = 2.4 (Truss)            E Brg Wid = 3.5 Min Req = 1.7 (Truss)            Bearings B &amp; E are a rigid surface.            Members not listed have forces less than 375#</p> <b>Maximum Top Chord Forces Per Ply (lbs)</b> <table border="1"> <thead> <tr> <th>Chords</th> <th>Tens.Comp.</th> <th>Chords</th> <th>Tens. Comp.</th> </tr> </thead> <tbody> <tr> <td>B - C</td> <td>1008 -3731</td> <td>D - E</td> <td>1008 -3726</td> </tr> <tr> <td>C - D</td> <td>867 -3308</td> <td></td> <td></td> </tr> </tbody> </table>						Gravity			Non-Gravity			Loc	R+	/R-	/Rh	/Rw	/U	/RL	B	2054	-/-	-/-	-/-	/556	-/-	E	2054	-/-	-/-	-/-	/556	-/-	Chords	Tens.Comp.	Chords	Tens. Comp.	B - C	1008 -3731	D - E	1008 -3726	C - D	867 -3308		
				Gravity			Non-Gravity																																									
Loc	R+	/R-	/Rh	/Rw	/U	/RL																																										
B	2054	-/-	-/-	-/-	/556	-/-																																										
E	2054	-/-	-/-	-/-	/556	-/-																																										
Chords	Tens.Comp.	Chords	Tens. Comp.																																													
B - C	1008 -3731	D - E	1008 -3726																																													
C - D	867 -3308																																															
<b>Lumber</b> Top chord: 2x4 SP #2; T2 2x4 SP M-31; Bot chord: 2x4 SP #2; B2 2x4 SP M-31; Webs: 2x4 SP #3;				<b>Maximum Bot Chord Forces Per Ply (lbs)</b> <table border="1"> <thead> <tr> <th>Chords</th> <th>Tens.Comp.</th> <th>Chords</th> <th>Tens. Comp.</th> </tr> </thead> <tbody> <tr> <td>B - H</td> <td>3254 -866</td> <td>G - E</td> <td>3250 -867</td> </tr> <tr> <td>H - G</td> <td>3283 -866</td> <td></td> <td></td> </tr> </tbody> </table>						Chords	Tens.Comp.	Chords	Tens. Comp.	B - H	3254 -866	G - E	3250 -867	H - G	3283 -866																													
Chords	Tens.Comp.	Chords	Tens. Comp.																																													
B - H	3254 -866	G - E	3250 -867																																													
H - G	3283 -866																																															

<b>Special Loads</b> ----(Lumber Dur.Fac.=1.25 / Plate Dur.Fac.=1.25) TC: From 62 plf at -1.50 to 62 plf at 7.00 TC: From 31 plf at 7.00 to 31 plf at 13.00 TC: From 62 plf at 13.00 to 62 plf at 21.50 BC: From 4 plf at -1.50 to 4 plf at 0.00 BC: From 20 plf at 0.00 to 20 plf at 7.15 BC: From 10 plf at 7.15 to 10 plf at 12.97 BC: From 20 plf at 12.97 to 20 plf at 20.00 BC: From 4 plf at 20.00 to 4 plf at 21.50 TC: 434 lb Conc. Load at 7.03,12.97 TC: 187 lb Conc. Load at 9.06,10.94 BC: 503 lb Conc. Load at 7.03,12.97 BC: 129 lb Conc. Load at 9.06,10.94				<b>Maximum Web Forces Per Ply (lbs)</b> <table border="1"> <thead> <tr> <th>Webs</th> <th>Tens.Comp.</th> <th>Webs</th> <th>Tens. Comp.</th> </tr> </thead> <tbody> <tr> <td>C - H</td> <td>700 0</td> <td>G - D</td> <td>710 0</td> </tr> </tbody> </table>						Webs	Tens.Comp.	Webs	Tens. Comp.	C - H	700 0	G - D	710 0
Webs	Tens.Comp.	Webs	Tens. Comp.														
C - H	700 0	G - D	710 0														

**Purlins**  
 In lieu of structural panels use purlins to brace all flat TC @ 24" oc.

**Wind**  
 Wind loads and reactions based on MWFRS.  
 Wind loading based on both gable and hip roof types.

**Additional Notes**  
 The overall height of this truss excluding overhang is 3-10-3.

COA#0-278  
 Florida Certificate of Product Approval #FL1999  
 09/10/2025

**\*\*WARNING\*\* READ AND FOLLOW ALL NOTES ON THIS DRAWING!**  
**\*\*IMPORTANT\*\* FURNISH THIS DRAWING TO ALL CONTRACTORS INCLUDING THE INSTALLERS**  
 Trusses require extreme care in fabricating, handling, shipping, installing and bracing. Refer to and follow the latest edition of BCSI (Building Component Safety Information, by TPI and SBCA) for safety practices prior to performing these functions. Installers shall provide temporary bracing per BCSI. Unless noted otherwise, top chord shall have properly attached structural sheathing and bottom chord shall have a properly attached rigid ceiling. Locations shown for permanent lateral restraint of webs shall have continuous lateral restraint (CLR), installed with diagonal bracing installed on the CLR per BCSI sections B3, B7, or B10, as applicable. Apply plates to each face of truss and position as shown above and on the Joint Details, unless noted otherwise. Refer to drawings 160A-Z for standard plate positions. Refer to job's General Notes page for additional information.  
 Alpine, a division of ITW Building Components Group Inc. shall not be responsible for any deviation from this drawing, any failure to build the truss in conformance with ANSI/TPI 1, or for handling, shipping, installation and bracing of trusses. A seal on this drawing or cover page listing this drawing, indicates acceptance of professional engineering responsibility solely for the design shown. The suitability and use of this drawing for any structure is the responsibility of the Building Designer per ANSI/TPI 1 Sec.2.  
 For more information see these web sites: Alpine: alpineitw.com; TPI: tpinst.org; SBCA: sbcacomponents.com; ICC: iccsafe.org; AWC: awc.org

155 Harlem Ave  
 North Building, 4th Floor  
 Glenview, IL 60025

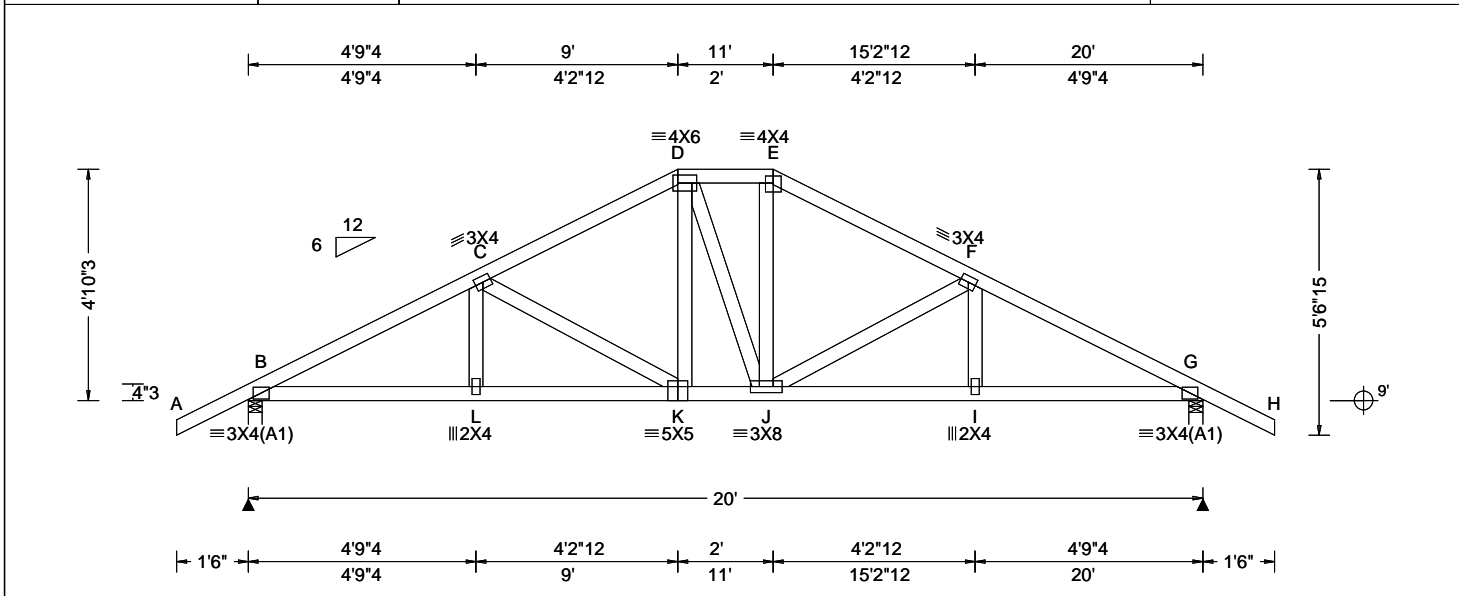

<b>Loading Criteria (psf)</b> TCCL: 20.00 TCCL: 10.00 BCLL: 0.00 BCDL: 10.00 Des Ld: 40.00 NCBCLL: 10.00 Soffit: 2.00 Load Duration: 1.25 Spacing: 24.0 "	<b>Wind Criteria</b> Wind Std: ASCE 7-22 Speed: 130 mph Enclosure: Closed Risk Category: II EXP: C Kzt: NA Mean Height: 15.00 ft TCCL: 4.2 psf BCDL: 3.0 psf MWFRS Parallel Dist: h/2 to h C&C Dist a: 3.00 ft Loc. from endwall: not in 9.00 ft GCpi: 0.18 Wind Duration: 1.60	<b>Snow Criteria (Pg,Pf in PSF)</b> Pg: NA Ct: NA CAT: NA Pf: NA Ce: NA Lu: NA Cs: NA Snow Duration: NA Building Code: FBC 8th Ed. 2023 Res. TPI Std: 2014 Rep Fac: Yes FT/RT:20(0)/10(0) Plate Type(s): WAVE	<b>Defl/CSI Criteria</b> PP Deflection in loc L/defl L/# VERT(LL): 0.042 K 999 240 VERT(CL): 0.083 K 999 180 HORZ(LL): 0.018 G - - HORZ(TL): 0.036 G - - Creep Factor: 2.0 Max TC CSI: 0.221 Max BC CSI: 0.331 Max Web CSI: 0.177 VIEW Ver: 24.02.00D.0114.10	<b>▲ Maximum Reactions (lbs)</b> Gravity Non-Gravity Loc R+ /R- /Rh /Rw /U /RL B 924 /- /- /481 /229 /116 G 924 /- /- /481 /229 /- Wind reactions based on MWFRS B Brg Wid = 3.5 Min Req = 1.5 (Truss) G Brg Wid = 3.5 Min Req = 1.5 (Truss) Bearings B & G are a rigid surface. Members not listed have forces less than 375# <b>Maximum Top Chord Forces Per Ply (lbs)</b> Chords Tens.Comp. Chords Tens. Comp. B - C 541 -1384 E - F 479 -1025 C - D 482 -1030 F - G 540 -1383 D - E 472 -869
				<b>Lumber</b> Top chord: 2x4 SP #2; Bot chord: 2x4 SP #2; Webs: 2x4 SP #3; <b>Purlins</b> In lieu of structural panels use purlins to brace all flat TC @ 24" oc. <b>Wind</b> Wind loads based on MWFRS with additional C&C member design. Wind loading based on both gable and hip roof types. <b>Additional Notes</b> The overall height of this truss excluding overhang is 4-10-3.

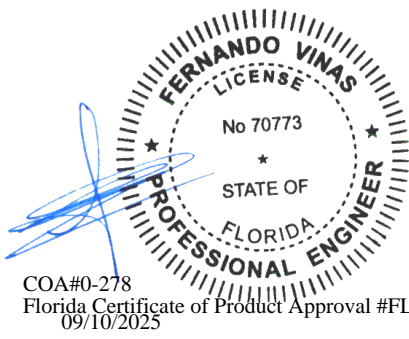

**\*\*WARNING\*\* READ AND FOLLOW ALL NOTES ON THIS DRAWING!**  
**\*\*IMPORTANT\*\* FURNISH THIS DRAWING TO ALL CONTRACTORS INCLUDING THE INSTALLERS**  
 Trusses require extreme care in fabricating, handling, shipping, installing and bracing. Refer to and follow the latest edition of BCSI (Building Component Safety Information, by TPI and SBCA) for safety practices prior to performing these functions. Installers shall provide temporary bracing per BCSI. Unless noted otherwise, top chord shall have properly attached structural sheathing and bottom chord shall have a properly attached rigid ceiling. Locations shown for permanent lateral restraint of webs shall have continuous lateral restraint (CLR), installed with diagonal bracing installed on the CLR per BCSI sections B3, B7, or B10, as applicable. Apply plates to each face of truss and position as shown above and on the Joint Details, unless noted otherwise. Refer to drawings 160A-Z for standard plate positions. Refer to job's General Notes page for additional information.  
 Alpine, a division of ITW Building Components Group Inc. shall not be responsible for any deviation from this drawing, any failure to build the truss in conformance with ANSI/TPI 1, or for handling, shipping, installation and bracing of trusses. A seal on this drawing or cover page listing this drawing, indicates acceptance of professional engineering responsibility solely for the design shown. The suitability and use of this drawing for any structure is the responsibility of the Building Designer per ANSI/TPI 1 Sec.2.  
 For more information see these web sites: Alpine: alpineitw.com; TPI: tpinst.org; SBCA: sbccomponents.com; ICC: iccsafe.org; AWC: awc.org



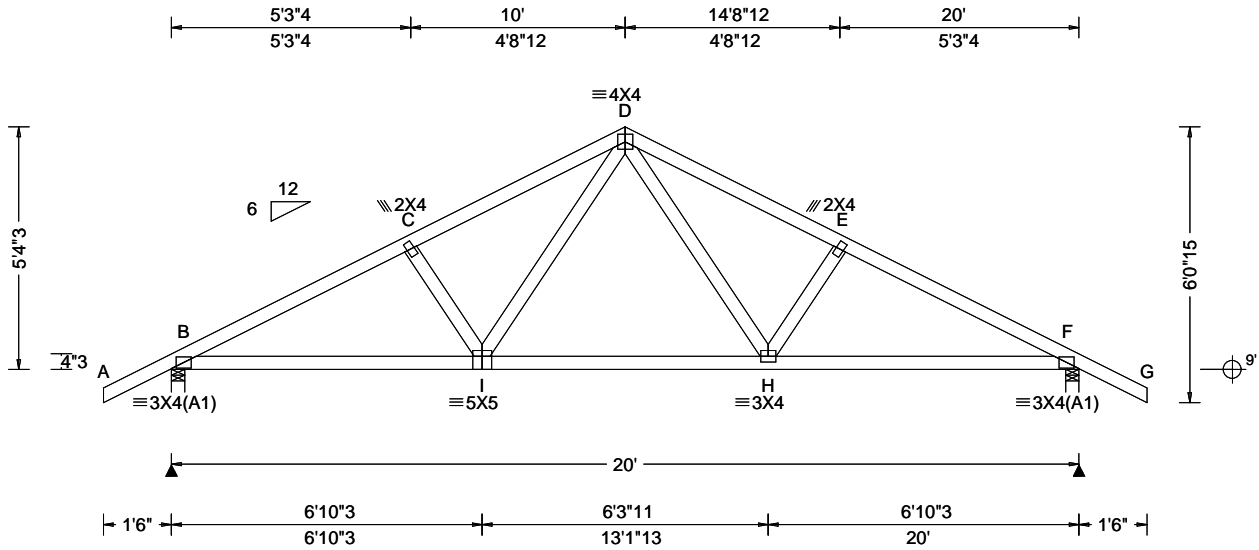

<b>Loading Criteria (psf)</b> TCCL: 20.00 TCCL: 10.00 BCLL: 0.00 BCDL: 10.00 Des Ld: 40.00 NCBCLL: 10.00 Soffit: 2.00 Load Duration: 1.25 Spacing: 24.0 "	<b>Wind Criteria</b> Wind Std: ASCE 7-22 Speed: 130 mph Enclosure: Closed Risk Category: II EXP: C Kzt: NA Mean Height: 15.00 ft TCCL: 4.2 psf BCDL: 3.0 psf MWFRS Parallel Dist: h/2 to h C&C Dist a: 3.00 ft Loc. from endwall: not in 9.00 ft GCp: 0.18 Wind Duration: 1.60	<b>Snow Criteria (Pg,Pf in PSF)</b> Pg: NA Ct: NA CAT: NA Pf: NA Ce: NA Lu: NA Cs: NA Snow Duration: NA Building Code: FBC 8th Ed. 2023 Res. TPI Std: 2014 Rep Fac: Yes FT/RT:20(0)/10(0) Plate Type(s): WAVE	<b>Defl/CSI Criteria</b> PP Deflection in loc L/defl L/# VERT(LL): 0.041 H 999 240 VERT(CL): 0.082 H 999 180 HORZ(LL): 0.016 F - - HORZ(TL): 0.032 F - - Creep Factor: 2.0 Max TC CSI: 0.223 Max BC CSI: 0.462 Max Web CSI: 0.161 VIEW Ver: 24.02.00D.0114.10	<b>▲ Maximum Reactions (lbs)</b> <table border="1"> <thead> <tr> <th colspan="3">Gravity</th> <th colspan="3">Non-Gravity</th> </tr> <tr> <th>Loc</th> <th>R+</th> <th>/R-</th> <th>/Rh</th> <th>/Rw</th> <th>/U</th> <th>/RL</th> </tr> </thead> <tbody> <tr> <td>B</td> <td>924</td> <td>/-</td> <td>/-</td> <td>/480</td> <td>/228</td> <td>/129</td> </tr> <tr> <td>F</td> <td>924</td> <td>/-</td> <td>/-</td> <td>/480</td> <td>/228</td> <td>/-</td> </tr> </tbody> </table>	Gravity			Non-Gravity			Loc	R+	/R-	/Rh	/Rw	/U	/RL	B	924	/-	/-	/480	/228	/129	F	924	/-	/-	/480	/228	/-
				Gravity			Non-Gravity																								
Loc	R+	/R-	/Rh	/Rw	/U	/RL																									
B	924	/-	/-	/480	/228	/129																									
F	924	/-	/-	/480	/228	/-																									
<b>Wind reactions based on MWFRS</b> B Brg Wid = 3.5 Min Req = 1.5 (Truss) F Brg Wid = 3.5 Min Req = 1.5 (Truss) Bearings B & F are a rigid surface. Members not listed have forces less than 375# <b>Maximum Top Chord Forces Per Ply (lbs)</b> <table border="1"> <thead> <tr> <th>Chords</th> <th>Tens.Comp.</th> <th>Chords</th> <th>Tens. Comp.</th> </tr> </thead> <tbody> <tr> <td>B - C</td> <td>454 - 1356</td> <td>D - E</td> <td>456 - 1200</td> </tr> <tr> <td>C - D</td> <td>456 - 1199</td> <td>E - F</td> <td>453 - 1357</td> </tr> </tbody> </table>				Chords	Tens.Comp.	Chords	Tens. Comp.	B - C	454 - 1356	D - E	456 - 1200	C - D	456 - 1199	E - F	453 - 1357																
Chords	Tens.Comp.	Chords	Tens. Comp.																												
B - C	454 - 1356	D - E	456 - 1200																												
C - D	456 - 1199	E - F	453 - 1357																												

**Lumber**

Top chord: 2x4 SP #2;  
 Bot chord: 2x4 SP #2;  
 Webs: 2x4 SP #3;

**Wind**

Wind loads based on MWFRS with additional C&C member design.  
 Wind loading based on both gable and hip roof types.

**Additional Notes**

The overall height of this truss excluding overhang is 5-4-3.

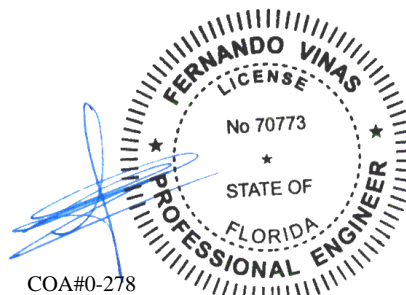

COA#0-278  
 Florida Certificate of Product Approval #FL1999  
 09/10/2025

**\*\*WARNING\*\* READ AND FOLLOW ALL NOTES ON THIS DRAWING!**  
**\*\*IMPORTANT\*\* FURNISH THIS DRAWING TO ALL CONTRACTORS INCLUDING THE INSTALLERS**  
 Trusses require extreme care in fabricating, handling, shipping, installing and bracing. Refer to and follow the latest edition of BCSI (Building Component Safety Information, by TPI and SBCA) for safety practices prior to performing these functions. Installers shall provide temporary bracing per BCSI. Unless noted otherwise, top chord shall have properly attached structural sheathing and bottom chord shall have a properly attached rigid ceiling. Locations shown for permanent lateral restraint of webs shall have continuous lateral restraint (CLR), installed with diagonal bracing installed on the CLR per BCSI sections B3, B7, or B10, as applicable. Apply plates to each face of truss and position as shown above and on the Joint Details, unless noted otherwise. Refer to drawings 160A-Z for standard plate positions. Refer to job's General Notes page for additional information.  
 Alpine, a division of ITW Building Components Group Inc. shall not be responsible for any deviation from this drawing, any failure to build the truss in conformance with ANSI/TPI 1, or for handling, shipping, installation and bracing of trusses. A seal on this drawing or cover page listing this drawing, indicates acceptance of professional engineering responsibility solely for the design shown. The suitability and use of this drawing for any structure is the responsibility of the Building Designer per ANSI/TPI 1 Sec.2.  
 For more information see these web sites: Alpine: alpineitw.com; TPI: tpinst.org; SBCA: sbccomponents.com; ICC: iccsafe.org; AWC: awc.org



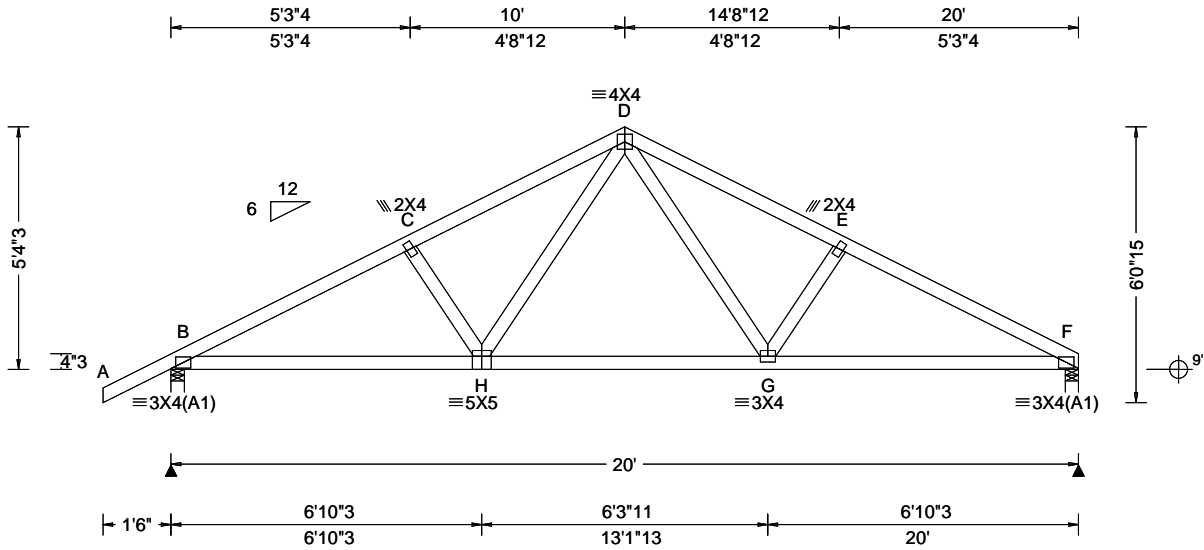

<b>Loading Criteria (psf)</b> TCCL: 20.00 TCDL: 10.00 BCLL: 0.00 BCDL: 10.00 Des Ld: 40.00 NCBCLL: 10.00 Soffit: 2.00 Load Duration: 1.25 Spacing: 24.0 "	<b>Wind Criteria</b> Wind Std: ASCE 7-22 Speed: 130 mph Enclosure: Closed Risk Category: II EXP: C Kzt: NA Mean Height: 15.00 ft TCDL: 4.2 psf BCDL: 3.0 psf MWFRS Parallel Dist: h to 2h C&C Dist a: 3.00 ft Loc. from endwall: not in 9.00 ft GCpi: 0.18 Wind Duration: 1.60	<b>Snow Criteria (Pg,Pf in PSF)</b> Pg: NA Ct: NA CAT: NA Pf: NA Ce: NA Lu: NA Cs: NA Snow Duration: NA Building Code: FBC 8th Ed. 2023 Res. TPI Std: 2014 Rep Fac: Yes FT/RT:20(0)/10(0) Plate Type(s): WAVE	<b>Defl/CSI Criteria</b> PP Deflection in loc L/defl L/# VERT(LL): 0.045 H 999 240 VERT(CL): 0.082 H 999 180 HORZ(LL): 0.018 F - - HORZ(TL): 0.033 F - - Creep Factor: 2.0 Max TC CSI: 0.252 Max BC CSI: 0.474 Max Web CSI: 0.171 VIEW Ver: 24.02.00D.0114.10	<b>▲ Maximum Reactions (lbs)</b> <table border="1"> <thead> <tr> <th rowspan="2">Loc</th> <th colspan="3">Gravity</th> <th colspan="3">Non-Gravity</th> </tr> <tr> <th>R+</th> <th>/R-</th> <th>/Rh</th> <th>/Rw</th> <th>/U</th> <th>/RL</th> </tr> </thead> <tbody> <tr> <td>B</td> <td>928</td> <td>-</td> <td>-</td> <td>/480</td> <td>/86</td> <td>/143</td> </tr> <tr> <td>F</td> <td>819</td> <td>-</td> <td>-</td> <td>/475</td> <td>/71</td> <td>-</td> </tr> </tbody> </table>						Loc	Gravity			Non-Gravity			R+	/R-	/Rh	/Rw	/U	/RL	B	928	-	-	/480	/86	/143	F	819	-	-	/475	/71	-
				Loc	Gravity			Non-Gravity																												
R+	/R-	/Rh	/Rw		/U	/RL																														
B	928	-	-	/480	/86	/143																														
F	819	-	-	/475	/71	-																														
<b>Maximum Top Chord Forces Per Ply (lbs)</b> <table border="1"> <thead> <tr> <th>Chords</th> <th>Tens.Comp.</th> <th>Chords</th> <th>Tens. Comp.</th> </tr> </thead> <tbody> <tr> <td>B - C</td> <td>462 -1365</td> <td>D - E</td> <td>476 -1226</td> </tr> <tr> <td>C - D</td> <td>464 -1208</td> <td>E - F</td> <td>472 -1384</td> </tr> </tbody> </table>				Chords	Tens.Comp.	Chords	Tens. Comp.	B - C	462 -1365	D - E	476 -1226	C - D	464 -1208	E - F	472 -1384	<b>Maximum Bot Chord Forces Per Ply (lbs)</b> <table border="1"> <thead> <tr> <th>Chords</th> <th>Tens.Comp.</th> <th>Chords</th> <th>Tens. Comp.</th> </tr> </thead> <tbody> <tr> <td>B - H</td> <td>1163 -366</td> <td>G - F</td> <td>1186 -361</td> </tr> <tr> <td>H - G</td> <td>798 -189</td> <td></td> <td></td> </tr> </tbody> </table>		Chords	Tens.Comp.	Chords	Tens. Comp.	B - H	1163 -366	G - F	1186 -361	H - G	798 -189									
Chords	Tens.Comp.	Chords	Tens. Comp.																																	
B - C	462 -1365	D - E	476 -1226																																	
C - D	464 -1208	E - F	472 -1384																																	
Chords	Tens.Comp.	Chords	Tens. Comp.																																	
B - H	1163 -366	G - F	1186 -361																																	
H - G	798 -189																																			
<b>Maximum Web Forces Per Ply (lbs)</b> <table border="1"> <thead> <tr> <th>Webs</th> <th>Tens.Comp.</th> <th>Webs</th> <th>Tens. Comp.</th> </tr> </thead> <tbody> <tr> <td>H - D</td> <td>420 -143</td> <td>D - G</td> <td>448 -158</td> </tr> </tbody> </table>				Webs	Tens.Comp.	Webs	Tens. Comp.	H - D	420 -143	D - G	448 -158	Wind reactions based on MWFRS B Brg Wid = 3.5 Min Req = 1.5 (Truss) F Brg Wid = 3.5 Min Req = 1.5 (Truss) Bearings B & F are a rigid surface. Members not listed have forces less than 375#																								
Webs	Tens.Comp.	Webs	Tens. Comp.																																	
H - D	420 -143	D - G	448 -158																																	

**Lumber**

Top chord: 2x4 SP #2;  
 Bot chord: 2x4 SP #2;  
 Webs: 2x4 SP #3;

**Wind**

Wind loads based on MWFRS with additional C&C member design.  
 Wind loading based on both gable and hip roof types.

**Additional Notes**

The overall height of this truss excluding overhang is 5-4-3.

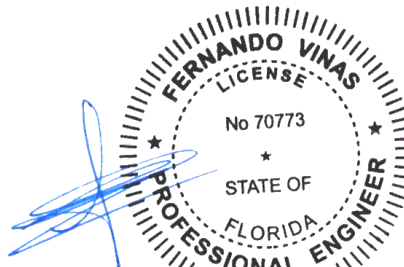

COA#0-278  
 Florida Certificate of Product Approval #FL1999  
 09/10/2025

**\*\*WARNING\*\* READ AND FOLLOW ALL NOTES ON THIS DRAWING!**  
**\*\*IMPORTANT\*\* FURNISH THIS DRAWING TO ALL CONTRACTORS INCLUDING THE INSTALLERS**  
 Trusses require extreme care in fabricating, handling, shipping, installing and bracing. Refer to and follow the latest edition of BCSI (Building Component Safety Information, by TPI and SBCA) for safety practices prior to performing these functions. Installers shall provide temporary bracing per BCSI. Unless noted otherwise, top chord shall have properly attached structural sheathing and bottom chord shall have a properly attached rigid ceiling. Locations shown for permanent lateral restraint of webs shall have continuous lateral restraint (CLR), installed with diagonal bracing installed on the CLR per BCSI sections B3, B7, or B10, as applicable. Apply plates to each face of truss and position as shown above and on the Joint Details, unless noted otherwise. Refer to drawings 160A-Z for standard plate positions. Refer to job's General Notes page for additional information.  
 Alpine, a division of ITW Building Components Group Inc. shall not be responsible for any deviation from this drawing, any failure to build the truss in conformance with ANSI/TPI 1, or for handling, shipping, installation and bracing of trusses. A seal on this drawing or cover page listing this drawing, indicates acceptance of professional engineering responsibility solely for the design shown. The suitability and use of this drawing for any structure is the responsibility of the Building Designer per ANSI/TPI 1 Sec.2.  
 For more information see these web sites: Alpine: alpineitw.com; TPI: tpinst.org; SBCA: sbcacomponents.com; ICC: iccsafe.org; AWC: awc.org



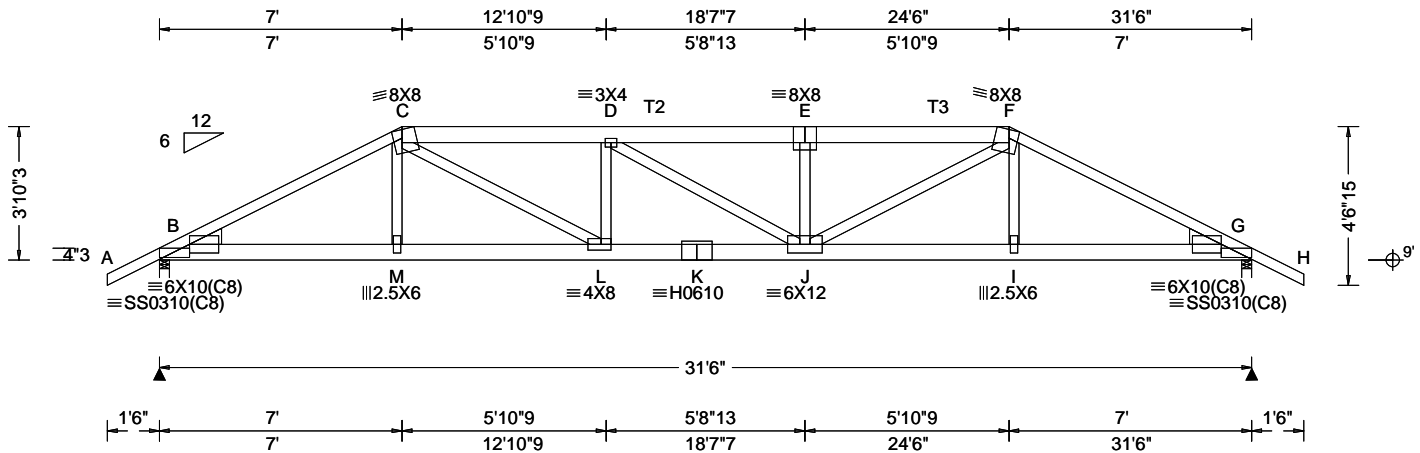

<b>Loading Criteria (psf)</b> TCLL: 20.00 TCDL: 10.00 BCLL: 0.00 BCDL: 10.00 Des Ld: 40.00 NCBCLL: 10.00 Soffit: 2.00 Load Duration: 1.25 Spacing: 24.0 "	<b>Wind Criteria</b> Wind Std: ASCE 7-22 Speed: 130 mph Enclosure: Closed Risk Category: II EXP: C Kzt: NA Mean Height: 15.00 ft TCDL: 4.2 psf BCDL: 3.0 psf MWFRS Parallel Dist: 0 to h/2 C&C Dist a: 3.15 ft Loc. from endwall: not in 4.50 ft GCp: 0.18 Wind Duration: 1.60	<b>Snow Criteria (Pg,Pf in PSF)</b> Pg: NA Ct: NA CAT: NA Pf: NA Ce: NA Lu: NA Cs: NA Snow Duration: NA  Building Code: FBC 8th Ed. 2023 Res. TPI Std: 2014 Rep Fac: Varies by Ld Case FT/RT:20(0)/10(0) Plate Type(s): 18SS, WAVE, HS	<b>Defl/CSI Criteria</b> PP Deflection in loc L/defl L/# VERT(LL): 0.280 E 999 240 VERT(CL): 0.561 E 667 180 HORZ(LL): 0.070 G - - HORZ(TL): 0.140 G - - Creep Factor: 2.0 Max TC CSI: 0.539 Max BC CSI: 0.514 Max Web CSI: 0.968  VIEW Ver: 24.02.00D.0114.10	<b>▲ Maximum Reactions (lbs)</b> Gravity Non-Gravity Loc R+ / R- / Rh / Rw / U / RL B 3237 -/- /- /- /903 -/ G 3237 -/- /- /- /903 -/ Wind reactions based on MWFRS B Brg Wid = 3.5 Min Req = 2.7 (Truss) G Brg Wid = 3.5 Min Req = 2.7 (Truss) Bearings B & G are a rigid surface. Members not listed have forces less than 375# <b>Maximum Top Chord Forces Per Ply (lbs)</b> Chords Tens.Comp. Chords Tens. Comp. B - C 1801 -6488 E - F 2225 -7913 C - D 2208 -7866 F - G 1802 -6492 D - E 2224 -7911
--	---	--	---	---

**Lumber**  
Top chord: 2x4 SP M-31; T2,T3 2x6 SP 2400f-2.0E;  
Bot chord: 2x6 SP 2400f-2.0E;  
Webs: 2x4 SP #3;  
Lt Wedge: 2x6 SP #2;Rt Wedge: 2x6 SP #2;

**Special Loads**  
-----(Lumber Dur.Fac.=1.25 / Plate Dur.Fac.=1.25)  
TC: From 62 plf at -1.50 to 62 plf at 7.00  
TC: From 31 plf at 7.00 to 31 plf at 24.50  
TC: From 62 plf at 24.50 to 62 plf at 33.00  
BC: From 4 plf at -1.50 to 4 plf at 0.00  
BC: From 20 plf at 0.00 to 20 plf at 7.03  
BC: From 10 plf at 7.03 to 10 plf at 24.47  
BC: From 20 plf at 24.47 to 20 plf at 31.50  
BC: From 4 plf at 31.50 to 4 plf at 33.00  
TC: 434 lb Conc. Load at 7.03,24.47  
TC: 187 lb Conc. Load at 9.06,11.06,13.06,15.06  
16.44,18.44,20.44,22.44  
BC: 503 lb Conc. Load at 7.03,24.47  
BC: 129 lb Conc. Load at 9.06,11.06,13.06,15.06  
16.44,18.44,20.44,22.44

**Purlins**  
In lieu of structural panels use purlins to brace all flat TC @ 24" oc.

**Wind**  
Wind loads and reactions based on MWFRS.  
Wind loading based on both gable and hip roof types.

**Additional Notes**  
The overall height of this truss excluding overhang is 3-10-3.

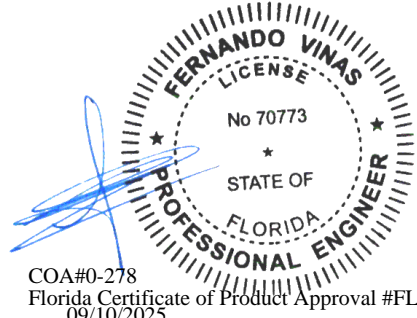

COA#0-278  
Florida Certificate of Product Approval #FL1999  
09/10/2025

**\*\*WARNING\*\* READ AND FOLLOW ALL NOTES ON THIS DRAWING!**  
**\*\*IMPORTANT\*\* FURNISH THIS DRAWING TO ALL CONTRACTORS INCLUDING THE INSTALLERS**  
Trusses require extreme care in fabricating, handling, shipping, installing and bracing. Refer to and follow the latest edition of BCSI (Building Component Safety Information, by TPI and SBCA) for safety practices prior to performing these functions. Installers shall provide temporary bracing per BCSI. Unless noted otherwise, top chord shall have properly attached structural sheathing and bottom chord shall have a properly attached rigid ceiling. Locations shown for permanent lateral restraint of webs shall have continuous lateral restraint (CLR), installed with diagonal bracing installed on the CLR per BCSI sections B3, B7, or B10, as applicable. Apply plates to each face of truss and position as shown above and on the Joint Details, unless noted otherwise. Refer to drawings 160A-Z for standard plate positions. Refer to job's General Notes page for additional information.  
Alpine, a division of ITW Building Components Group Inc. shall not be responsible for any deviation from this drawing, any failure to build the truss in conformance with ANSI/TPI 1, or for handling, shipping, installation and bracing of trusses. A seal on this drawing or cover page listing this drawing, indicates acceptance of professional engineering responsibility solely for the design shown. The suitability and use of this drawing for any structure is the responsibility of the Building Designer per ANSI/TPI 1 Sec.2.  
For more information see these web sites: Alpine: alpineitw.com; TPI: tpinst.org; SBCA: sbccomponents.com; ICC: iccsafe.org; AWC: awc.org



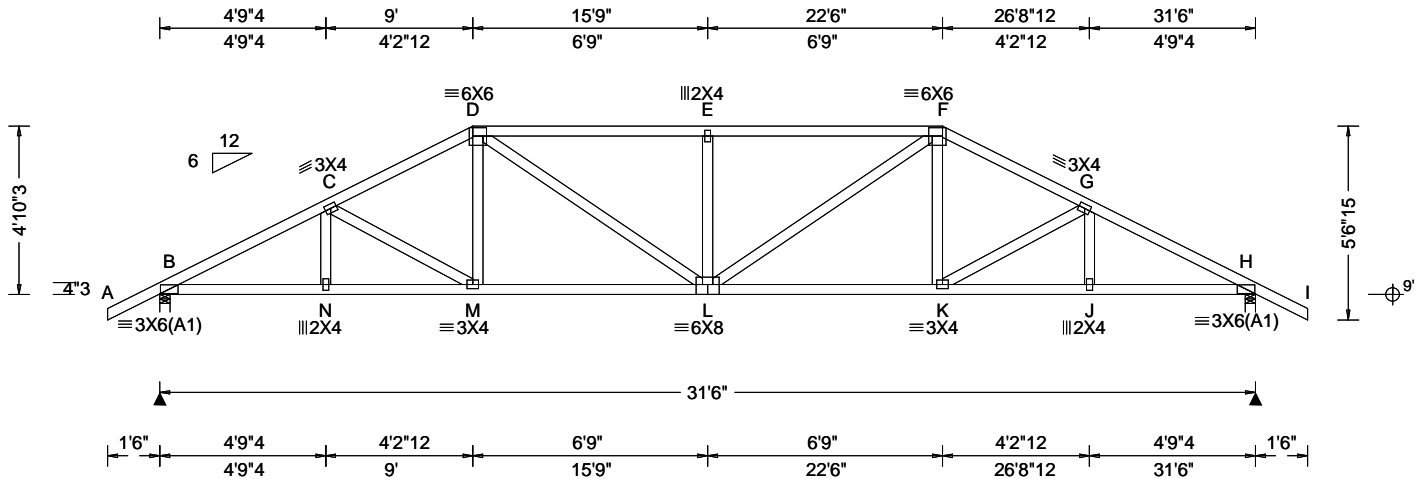

<b>Loading Criteria (psf)</b> TCLL: 20.00 TCDL: 10.00 BCLL: 0.00 BCDL: 10.00 Des Ld: 40.00 NCBCLL: 10.00 Soffit: 2.00 Load Duration: 1.25 Spacing: 24.0 "	<b>Wind Criteria</b> Wind Std: ASCE 7-22 Speed: 130 mph Enclosure: Closed Risk Category: II EXP: C Kzt: NA Mean Height: 15.00 ft TCDL: 4.2 psf BCDL: 3.0 psf MWFRS Parallel Dist: h/2 to h C&C Dist a: 3.15 ft Loc. from endwall: not in 9.00 ft GCp: 0.18 Wind Duration: 1.60	<b>Snow Criteria (Pg,Pf in PSF)</b> Pg: NA Ct: NA CAT: NA Pf: NA Ce: NA Lu: NA Cs: NA Snow Duration: NA  Building Code: FBC 8th Ed. 2023 Res. TPI Std: 2014 Rep Fac: Yes FT/RT:20(0)/10(0) Plate Type(s): WAVE	<b>Defl/CSI Criteria</b> PP Deflection in loc L/defl L/# VERT(LL): 0.138 E 999 240 VERT(CL): 0.279 E 999 180 HORZ(LL): 0.048 H - - HORZ(TL): 0.098 H - - Creep Factor: 2.0 Max TC CSI: 0.643 Max BC CSI: 0.641 Max Web CSI: 0.426  VIEW Ver: 24.02.00D.0114.10	<b>▲ Maximum Reactions (lbs)</b> Gravity Non-Gravity Loc R+ / R- / Rh / Rw / U / RL B 1397 /- /- /743 /350 /116 H 1397 /- /- /743 /350 /- Wind reactions based on MWFRS B Brg Wid = 3.5 Min Req = 1.6 (Truss) H Brg Wid = 3.5 Min Req = 1.6 (Truss) Bearings B & H are a rigid surface. Members not listed have forces less than 375# <b>Maximum Top Chord Forces Per Ply (lbs)</b> Chords Tens.Comp. Chords Tens. Comp. B - C 1093 -2366 E - F 1274 -2254 C - D 1074 -2082 F - G 1074 -2082 D - E 1274 -2254 G - H 1094 -2366
--	---	--	---	--

**Lumber**

Top chord: 2x4 SP #2;  
Bot chord: 2x4 SP #2;  
Webs: 2x4 SP #3;

**Purlins**

In lieu of structural panels use purlins to brace all flat TC @ 24" oc.

**Wind**

Wind loads based on MWFRS with additional C&C member design.  
Wind loading based on both gable and hip roof types.

**Additional Notes**

The overall height of this truss excluding overhang is 4-10-3.

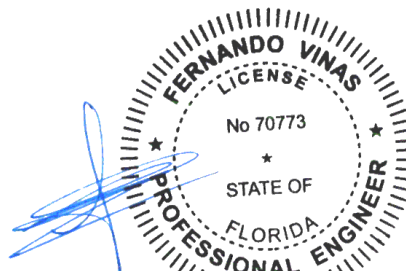

COA#0-278  
Florida Certificate of Product Approval #FL1999  
09/10/2025

**\*\*WARNING\*\* READ AND FOLLOW ALL NOTES ON THIS DRAWING!**  
**\*\*IMPORTANT\*\* FURNISH THIS DRAWING TO ALL CONTRACTORS INCLUDING THE INSTALLERS**  
Trusses require extreme care in fabricating, handling, shipping, installing and bracing. Refer to and follow the latest edition of BCSI (Building Component Safety Information, by TPI and SBCA) for safety practices prior to performing these functions. Installers shall provide temporary bracing per BCSI. Unless noted otherwise, top chord shall have properly attached structural sheathing and bottom chord shall have a properly attached rigid ceiling. Locations shown for permanent lateral restraint of webs shall have continuous lateral restraint (CLR), installed with diagonal bracing installed on the CLR per BCSI sections B3, B7, or B10, as applicable. Apply plates to each face of truss and position as shown above and on the Joint Details, unless noted otherwise. Refer to drawings 160A-Z for standard plate positions. Refer to job's General Notes page for additional information.  
Alpine, a division of ITW Building Components Group Inc. shall not be responsible for any deviation from this drawing, any failure to build the truss in conformance with ANSI/TPI 1, or for handling, shipping, installation and bracing of trusses. A seal on this drawing or cover page listing this drawing, indicates acceptance of professional engineering responsibility solely for the design shown. The suitability and use of this drawing for any structure is the responsibility of the Building Designer per ANSI/TPI 1 Sec.2.  
For more information see these web sites: Alpine: [alpineitw.com](http://alpineitw.com); TPI: [tpinst.org](http://tpinst.org); SBCA: [sbcacomponents.com](http://sbcacomponents.com); ICC: [iccsafe.org](http://iccsafe.org); AWC: [awc.org](http://awc.org)



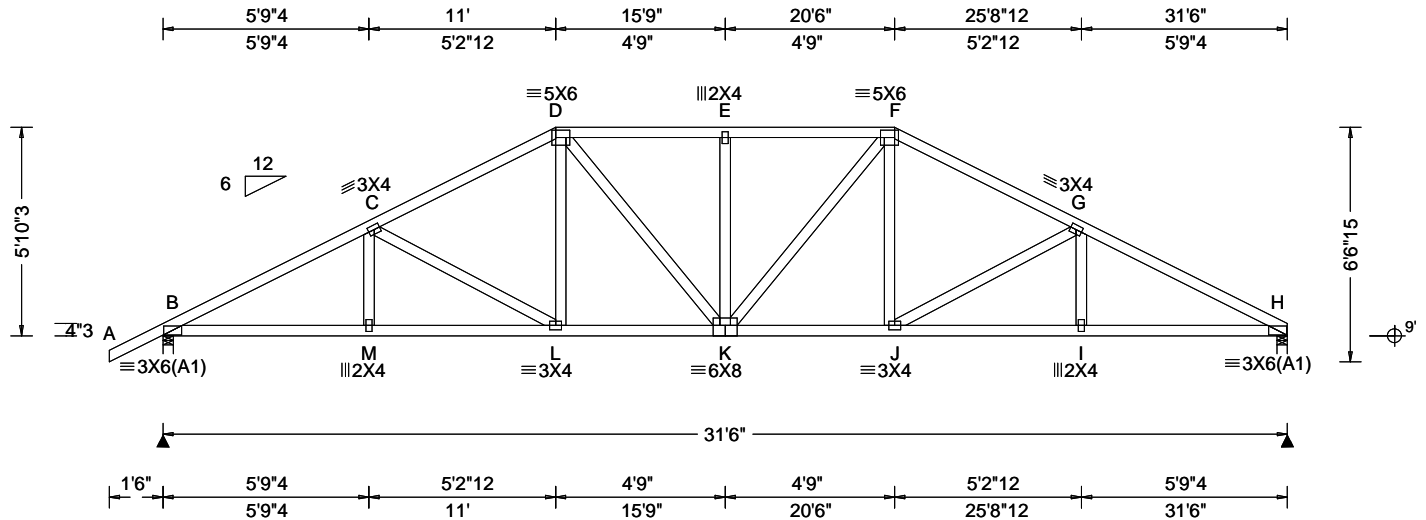

<b>Loading Criteria (psf)</b> TCLL: 20.00 TCDL: 10.00 BCLL: 0.00 BCDL: 10.00 Des Ld: 40.00 NCBCLL: 10.00 Soffit: 2.00 Load Duration: 1.25 Spacing: 24.0 "	<b>Wind Criteria</b> Wind Std: ASCE 7-22 Speed: 130 mph Enclosure: Closed Risk Category: II EXP: C Kzt: NA Mean Height: 15.00 ft TCDL: 4.2 psf BCDL: 3.0 psf MWFRS Parallel Dist: h/2 to h C&C Dist a: 3.15 ft Loc. from endwall: not in 9.00 ft GCpi: 0.18 Wind Duration: 1.60	<b>Snow Criteria (Pg,Pf in PSF)</b> Pg: NA Ct: NA CAT: NA Pf: NA Ce: NA Lu: NA Cs: NA Snow Duration: NA  Building Code: FBC 8th Ed. 2023 Res. TPI Std: 2014 Rep Fac: Yes FT/RT:20(0)/10(0) Plate Type(s): WAVE	<b>Defl/CSI Criteria</b> PP Deflection in loc L/defl L/# VERT(LL): 0.114 E 999 240 VERT(CL): 0.234 E 999 180 HORZ(LL): 0.047 H - - HORZ(TL): 0.097 H - - Creep Factor: 2.0 Max TC CSI: 0.354 Max BC CSI: 0.562 Max Web CSI: 0.333  VIEW Ver: 24.02.00D.0114.10	<b>▲ Maximum Reactions (lbs)</b> Gravity Non-Gravity Loc R+ / R- / Rh / Rw / U / RL B 1400 /- /- /752 /349 /156 H 1294 /- /- /746 /318 /- Wind reactions based on MWFRS B Brg Wid = 3.5 Min Req = 1.7 (Truss) H Brg Wid = 3.5 Min Req = 1.5 (Truss) Bearings B & H are a rigid surface. Members not listed have forces less than 375# <b>Maximum Top Chord Forces Per Ply (lbs)</b> Chords Tens.Comp. Chords Tens. Comp. B - C 985 -2361 E - F 979 -1821 C - D 930 -1928 F - G 930 -1934 D - E 979 -1821 G - H 995 -2387
--	--	--	---	--

**Lumber**  
Top chord: 2x4 SP #2;  
Bot chord: 2x4 SP #2;  
Webs: 2x4 SP #3;

**Purlins**  
In lieu of structural panels use purlins to brace all flat TC @ 24" oc.

**Wind**  
Wind loads based on MWFRS with additional C&C member design.  
Wind loading based on both gable and hip roof types.

**Additional Notes**  
The overall height of this truss excluding overhang is 5-10-3.

<b>Maximum Bot Chord Forces Per Ply (lbs)</b>			
Chords	Tens.Comp.	Chords	Tens. Comp.
B - M	2042 -837	K - J	1662 -661
M - L	2040 -838	J - I	2067 -826
L - K	1658 -684	I - H	2070 -825
<b>Maximum Web Forces Per Ply (lbs)</b>			
Webs	Tens.Comp.	Webs	Tens. Comp.
C - L	177 -441	F - J	379 -70
D - L	375 -65	J - G	190 -467

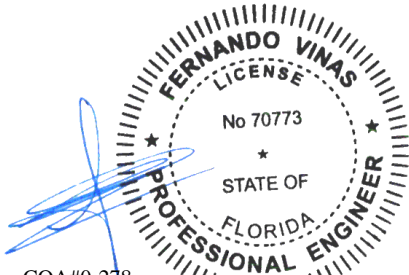

COA#0-278  
Florida Certificate of Product Approval #FL1999  
09/10/2025

**\*\*WARNING\*\* READ AND FOLLOW ALL NOTES ON THIS DRAWING!**  
**\*\*IMPORTANT\*\* FURNISH THIS DRAWING TO ALL CONTRACTORS INCLUDING THE INSTALLERS**  
Trusses require extreme care in fabricating, handling, shipping, installing and bracing. Refer to and follow the latest edition of BCSI (Building Component Safety Information, by TPI and SBCA) for safety practices prior to performing these functions. Installers shall provide temporary bracing per BCSI. Unless noted otherwise, top chord shall have properly attached structural sheathing and bottom chord shall have a properly attached rigid ceiling. Locations shown for permanent lateral restraint of webs shall have continuous lateral restraint (CLR), installed with diagonal bracing installed on the CLR per BCSI sections B3, B7, or B10, as applicable. Apply plates to each face of truss and position as shown above and on the Joint Details, unless noted otherwise. Refer to drawings 160A-Z for standard plate positions. Refer to job's General Notes page for additional information.  
Alpine, a division of ITW Building Components Group Inc. shall not be responsible for any deviation from this drawing, any failure to build the truss in conformance with ANSI/TPI 1, or for handling, shipping, installation and bracing of trusses. A seal on this drawing or cover page listing this drawing, indicates acceptance of professional engineering responsibility solely for the design shown. The suitability and use of this drawing for any structure is the responsibility of the Building Designer per ANSI/TPI 1 Sec.2.  
For more information see these web sites: Alpine: alpineitw.com; TPI: tpinst.org; SBCA: sbcacomponents.com; ICC: iccsafe.org; AWC: awc.org



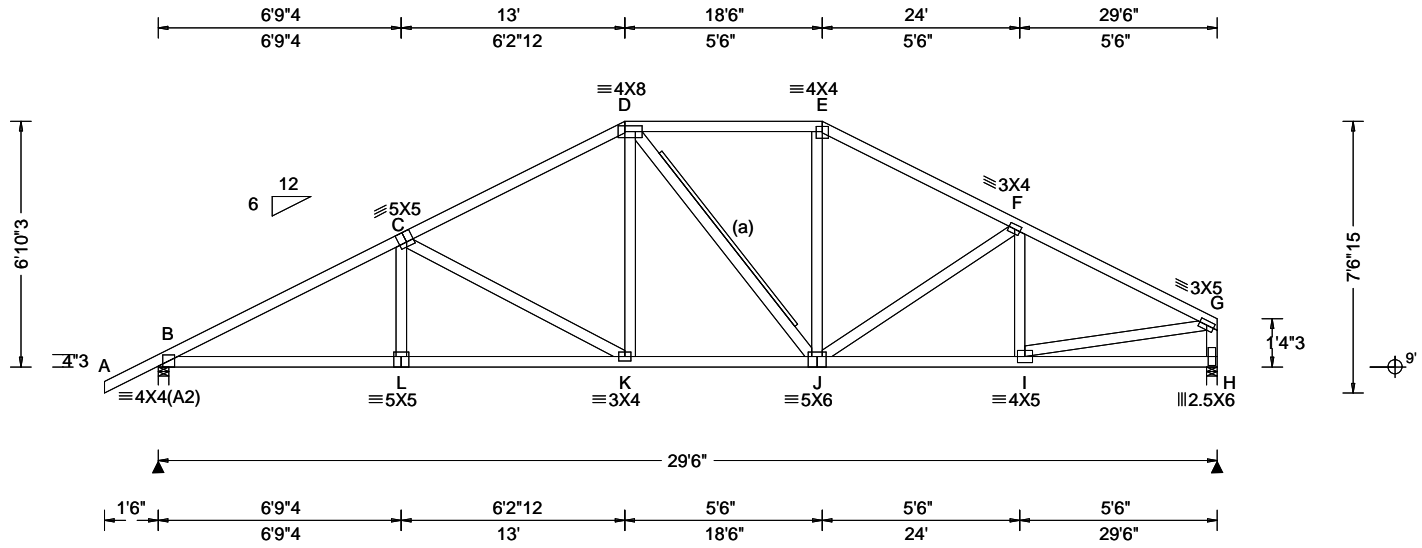

<b>Loading Criteria (psf)</b> TCLL: 20.00 TCDL: 10.00 BCLL: 0.00 BCDL: 10.00 Des Ld: 40.00 NCBCLL: 10.00 Soffit: 2.00 Load Duration: 1.25 Spacing: 24.0 "	<b>Wind Criteria</b> Wind Std: ASCE 7-22 Speed: 130 mph Enclosure: Closed Risk Category: II EXP: C Kzt: NA Mean Height: 15.00 ft TCDL: 4.2 psf BCDL: 3.0 psf MWFRS Parallel Dist: h/2 to h C&C Dist a: 3.00 ft Loc. from endwall: not in 9.00 ft GCpi: 0.18 Wind Duration: 1.60	<b>Snow Criteria (Pg,Pf in PSF)</b> Pg: NA Ct: NA CAT: NA Pf: NA Ce: NA Lu: NA Cs: NA Snow Duration: NA  Building Code: FBC 8th Ed. 2023 Res. TPI Std: 2014 Rep Fac: Yes FT/RT:20(0)/10(0) Plate Type(s): WAVE	<b>Defl/CSI Criteria</b> PP Deflection in loc L/defl L/# VERT(LL): 0.081 K 999 240 VERT(CL): 0.165 K 999 180 HORZ(LL): 0.031 H - - HORZ(TL): 0.064 H - - Creep Factor: 2.0 Max TC CSI: 0.428 Max BC CSI: 0.553 Max Web CSI: 0.568  VIEW Ver: 24.02.00D.0114.10	<b>▲ Maximum Reactions (lbs)</b> Gravity Non-Gravity Loc R+ / R- / Rh / Rw / U / RL B 1324 - / - / /719 /328 /182 H 1206 - / - / /681 /295 - / - Wind reactions based on MWFRS B Brg Wid = 3.5 Min Req = 1.6 (Truss) H Brg Wid = 3.5 Min Req = 1.5 (Truss) Bearings B & H are a rigid surface. Members not listed have forces less than 375# <b>Maximum Top Chord Forces Per Ply (lbs)</b> Chords Tens.Comp. Chords Tens. Comp. B - C 794 -2165 E - F 691 -1520 C - D 715 -1609 F - G 648 -1709 D - E 674 -1294
--	--	--	---	---

**Lumber**

Top chord: 2x4 SP #2;  
Bot chord: 2x4 SP #2;  
Webs: 2x4 SP #3;

**Bracing**

(a) 1x4 #3SRB SPF-S or better "T" reinforcement.  
80% length of web member. Attach with 8d Box or Gun (0.113"x2.5",min.)nails @ 6" oc.

**Purlins**

In lieu of structural panels use purlins to brace all flat TC @ 24" oc.

**Wind**

Wind loads based on MWFRS with additional C&C member design.  
Right end vertical not exposed to wind pressure.  
Wind loading based on both gable and hip roof types.

**Additional Notes**

The overall height of this truss excluding overhang is 6-10-3.

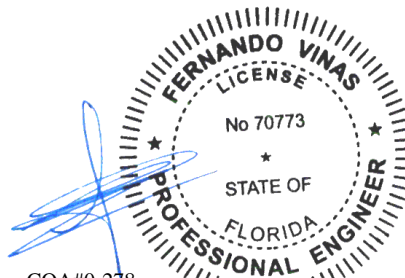

COA#0-278  
Florida Certificate of Product Approval #FL1999  
09/10/2025

**\*\*WARNING\*\* READ AND FOLLOW ALL NOTES ON THIS DRAWING!**  
**\*\*IMPORTANT\*\* FURNISH THIS DRAWING TO ALL CONTRACTORS INCLUDING THE INSTALLERS**  
Trusses require extreme care in fabricating, handling, shipping, installing and bracing. Refer to and follow the latest edition of BCSI (Building Component Safety Information, by TPI and SBCA) for safety practices prior to performing these functions. Installers shall provide temporary bracing per BCSI. Unless noted otherwise, top chord shall have properly attached structural sheathing and bottom chord shall have a properly attached rigid ceiling. Locations shown for permanent lateral restraint of webs shall have continuous lateral restraint (CLR), installed with diagonal bracing installed on the CLR per BCSI sections B3, B7, or B10, as applicable. Apply plates to each face of truss and position as shown above and on the Joint Details, unless noted otherwise. Refer to drawings 160A-Z for standard plate positions. Refer to job's General Notes page for additional information.  
Alpine, a division of ITW Building Components Group Inc. shall not be responsible for any deviation from this drawing, any failure to build the truss in conformance with ANSI/TPI 1, or for handling, shipping, installation and bracing of trusses. A seal on this drawing or cover page listing this drawing, indicates acceptance of professional engineering responsibility solely for the design shown. The suitability and use of this drawing for any structure is the responsibility of the Building Designer per ANSI/TPI 1 Sec.2.  
For more information see these web sites: Alpine: alpineitw.com; TPI: tpinst.org; SBCA: sbccomponents.com; ICC: iccsafe.org; AWC: awc.org



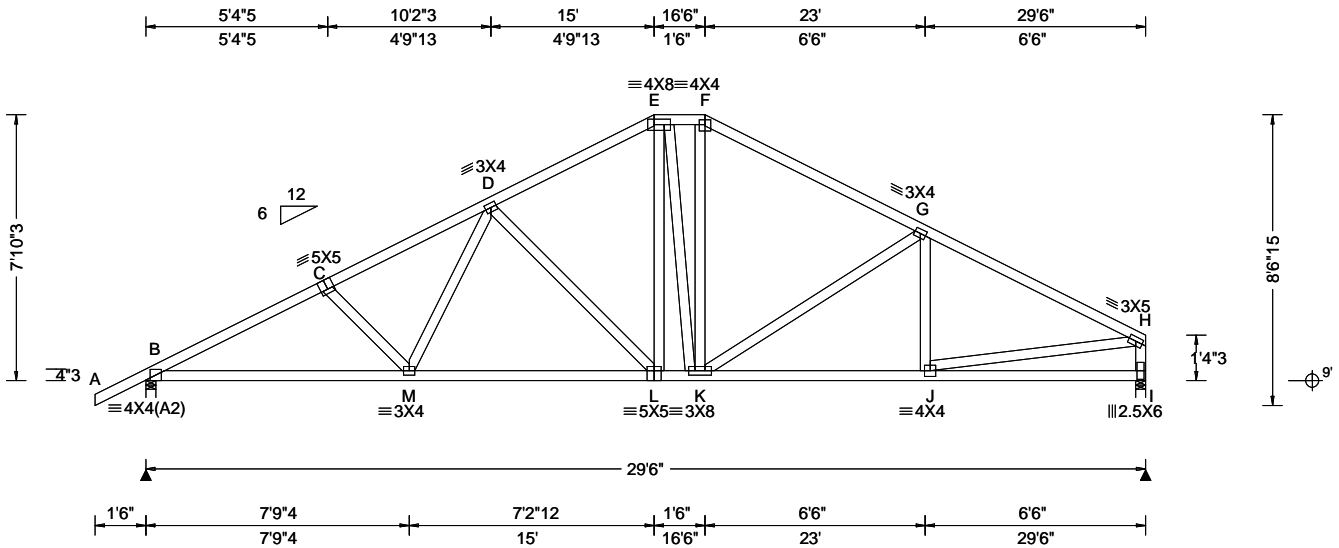

<b>Loading Criteria (psf)</b> TCLL: 20.00 TCDL: 10.00 BCLL: 0.00 BCDL: 10.00 Des Ld: 40.00 NCBCLL: 10.00 Soffit: 2.00 Load Duration: 1.25 Spacing: 24.0 "	<b>Wind Criteria</b> Wind Std: ASCE 7-22 Speed: 130 mph Enclosure: Closed Risk Category: II EXP: C Kzt: NA Mean Height: 15.00 ft TCDL: 4.2 psf BCDL: 3.0 psf MWFRS Parallel Dist: h to 2h C&C Dist a: 3.00 ft Loc. from endwall: not in 9.00 ft GCpi: 0.18 Wind Duration: 1.60	<b>Snow Criteria (Pg,Pf in PSF)</b> Pg: NA Ct: NA CAT: NA Pf: NA Ce: NA Lu: NA Cs: NA Snow Duration: NA  Building Code: FBC 8th Ed. 2023 Res. TPI Std: 2014 Rep Fac: Yes FT/RT:20(0)/10(0) Plate Type(s): WAVE	<b>Defl/CSI Criteria</b> PP Deflection in loc L/defl L/# VERT(LL): 0.084 D 999 240 VERT(CL): 0.172 D 999 180 HORZ(LL): 0.030 I - - HORZ(TL): 0.061 I - - Creep Factor: 2.0 Max TC CSI: 0.565 Max BC CSI: 0.676 Max Web CSI: 0.552  VIEW Ver: 24.02.00D.0114.10	<b>▲ Maximum Reactions (lbs)</b> Gravity Non-Gravity Loc R+ / R- / Rh / Rw / U / RL B 1324 - / - / /719 /136 /208 I 1206 - / - / /682 /111 - Wind reactions based on MWFRS B Brg Wid = 3.5 Min Req = 1.6 (Truss) I Brg Wid = 3.5 Min Req = 1.5 (Truss) Bearings B & I are a rigid surface. Members not listed have forces less than 375# <b>Maximum Top Chord Forces Per Ply (lbs)</b> Chords Tens.Comp. Chords Tens. Comp. B - C 673 -2196 E - F 539 -1181 C - D 651 -1989 F - G 548 -1414 D - E 558 -1402 G - H 550 -1745  <b>Maximum Bot Chord Forces Per Ply (lbs)</b> Chords Tens.Comp. Chords Tens. Comp. B - M 1900 -597 L - K 1186 -301 M - L 1568 -468 K - J 1497 -435  <b>Maximum Web Forces Per Ply (lbs)</b> Webs Tens.Comp. Webs Tens. Comp. M - D 424 -67 K - G 183 -387 D - L 240 -553 J - H 1449 -410 E - L 478 -146 H - I 385 -1151
--	---	--	---	---

**Lumber**

Top chord: 2x4 SP #2;  
Bot chord: 2x4 SP #2;  
Webs: 2x4 SP #3;

**Purlins**

In lieu of structural panels use purlins to brace all flat TC @ 24" oc.

**Wind**

Wind loads based on MWFRS with additional C&C member design.  
Right end vertical not exposed to wind pressure.  
Wind loading based on both gable and hip roof types.

**Additional Notes**

The overall height of this truss excluding overhang is 7-10-3.

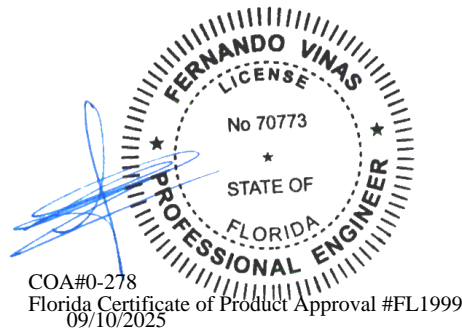

**\*\*WARNING\*\* READ AND FOLLOW ALL NOTES ON THIS DRAWING!**  
**\*\*IMPORTANT\*\* FURNISH THIS DRAWING TO ALL CONTRACTORS INCLUDING THE INSTALLERS**  
Trusses require extreme care in fabricating, handling, shipping, installing and bracing. Refer to and follow the latest edition of BCSI (Building Component Safety Information, by TPI and SBCA) for safety practices prior to performing these functions. Installers shall provide temporary bracing per BCSI. Unless noted otherwise, top chord shall have properly attached structural sheathing and bottom chord shall have a properly attached rigid ceiling. Locations shown for permanent lateral restraint of webs shall have continuous lateral restraint (CLR), installed with diagonal bracing installed on the CLR per BCSI sections B3, B7, or B10, as applicable. Apply plates to each face of truss and position as shown above and on the Joint Details, unless noted otherwise. Refer to drawings 160A-Z for standard plate positions. Refer to job's General Notes page for additional information.  
Alpine, a division of ITW Building Components Group Inc. shall not be responsible for any deviation from this drawing, any failure to build the truss in conformance with ANSI/TPI 1, or for handling, shipping, installation and bracing of trusses. A seal on this drawing or cover page listing this drawing, indicates acceptance of professional engineering responsibility solely for the design shown. The suitability and use of this drawing for any structure is the responsibility of the Building Designer per ANSI/TPI 1 Sec.2.  
For more information see these web sites: Alpine: alpineitw.com; TPI: tpinst.org; SBCA: sbccomponents.com; ICC: iccsafe.org; AWC: awc.org



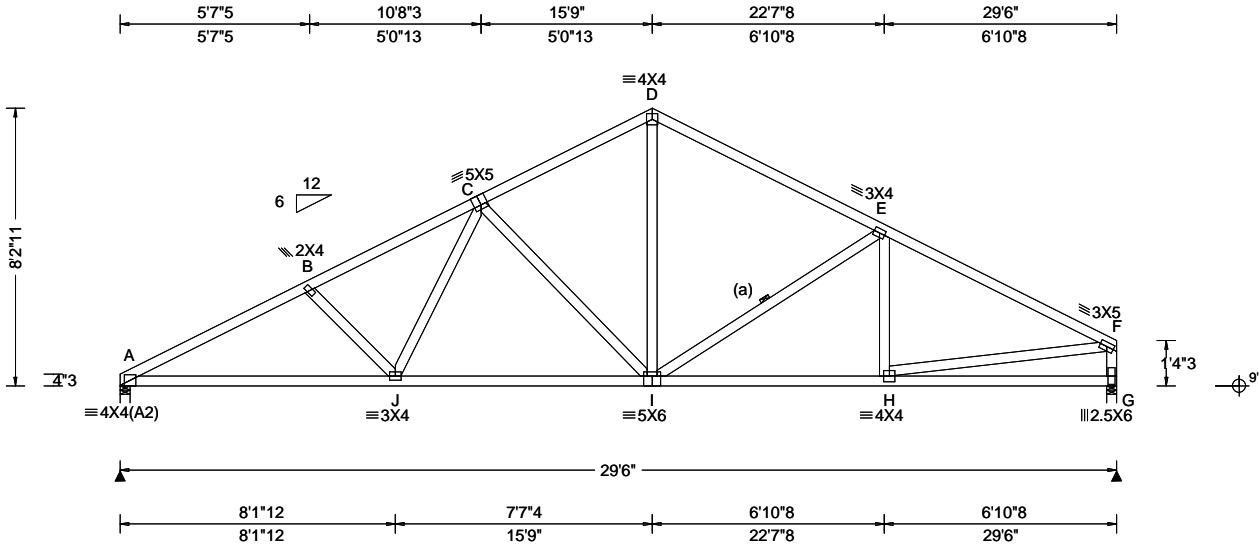

<b>Loading Criteria (psf)</b> TCLL: 20.00 TCDL: 10.00 BCLL: 0.00 BCDL: 10.00 Des Ld: 40.00 NCBCLL: 10.00 Soffit: 2.00 Load Duration: 1.25 Spacing: 24.0 "	<b>Wind Criteria</b> Wind Std: ASCE 7-22 Speed: 130 mph Enclosure: Closed Risk Category: II EXP: C Kzt: NA Mean Height: 15.00 ft TCDL: 4.2 psf BCDL: 3.0 psf MWFRS Parallel Dist: h to 2h C&C Dist a: 3.00 ft Loc. from endwall: not in 9.00 ft GCpi: 0.18 Wind Duration: 1.60	<b>Snow Criteria (Pg,Pf in PSF)</b> Pg: NA Ct: NA CAT: NA Pf: NA Ce: NA Lu: NA Cs: NA Snow Duration: NA  Building Code: FBC 8th Ed. 2023 Res. TPI Std: 2014 Rep Fac: Yes FT/RT:20(0)/10(0) Plate Type(s): WAVE	<b>Defl/CSI Criteria</b> PP Deflection in loc L/defl L/# VERT(LL): 0.084 C 999 240 VERT(CL): 0.173 C 999 180 HORZ(LL): 0.030 G - - HORZ(TL): 0.061 G - - Creep Factor: 2.0 Max TC CSI: 0.653 Max BC CSI: 0.723 Max Web CSI: 0.592  VIEW Ver: 24.02.00D.0114.10	<b>▲ Maximum Reactions (lbs)</b> Gravity Non-Gravity Loc R+ / R- / Rh / Rw / U / RL A 1221 - / - / /713 /109 /203 G 1209 - / - / /681 /107 - /- Wind reactions based on MWFRS A Brg Wid = 3.5 Min Req = 1.5 (Truss) G Brg Wid = 3.5 Min Req = 1.5 (Truss) Bearings A & G are a rigid surface. Members not listed have forces less than 375# <b>Maximum Top Chord Forces Per Ply (lbs)</b> Chords Tens.Comp. Chords Tens. Comp. A - B 649 -2215 D - E 498 -1387 B - C 621 -1989 E - F 513 -1755 C - D 505 -1351  <b>Maximum Bot Chord Forces Per Ply (lbs)</b> Chords Tens.Comp. Chords Tens. Comp. A - J 1922 -563 I - H 1501 -396 J - I 1538 -409  <b>Maximum Web Forces Per Ply (lbs)</b> Webs Tens.Comp. Webs Tens. Comp. J - C 455 -99 I - E 205 -424 C - I 245 -564 H - F 1442 -368 D - I 788 -243 F - G 362 -1150
--	---	--	---	--

**Lumber**

Top chord: 2x4 SP #2;  
Bot chord: 2x4 SP #2;  
Webs: 2x4 SP #3;

**Bracing**

(a) Continuous lateral restraint equally spaced on member.

**Wind**

Wind loads based on MWFRS with additional C&C member design.  
Right end vertical not exposed to wind pressure.  
Wind loading based on both gable and hip roof types.

**Additional Notes**

The overall height of this truss excluding overhang is 8-2-11.

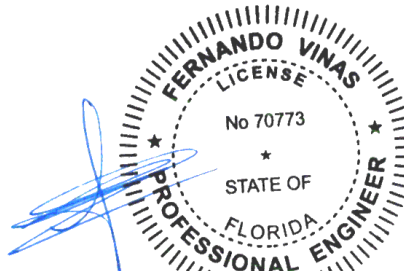

COA#0-278  
Florida Certificate of Product Approval #FL1999  
09/10/2025

**\*\*WARNING\*\* READ AND FOLLOW ALL NOTES ON THIS DRAWING!**  
**\*\*IMPORTANT\*\* FURNISH THIS DRAWING TO ALL CONTRACTORS INCLUDING THE INSTALLERS**  
Trusses require extreme care in fabricating, handling, shipping, installing and bracing. Refer to and follow the latest edition of BCSI (Building Component Safety Information, by TPI and SBCA) for safety practices prior to performing these functions. Installers shall provide temporary bracing per BCSI. Unless noted otherwise, top chord shall have properly attached structural sheathing and bottom chord shall have a properly attached rigid ceiling. Locations shown for permanent lateral restraint of webs shall have continuous lateral restraint (CLR), installed with diagonal bracing installed on the CLR per BCSI sections B3, B7, or B10, as applicable. Apply plates to each face of truss and position as shown above and on the Joint Details, unless noted otherwise. Refer to drawings 160A-Z for standard plate positions. Refer to job's General Notes page for additional information.  
Alpine, a division of ITW Building Components Group Inc. shall not be responsible for any deviation from this drawing, any failure to build the truss in conformance with ANSI/TPI 1, or for handling, shipping, installation and bracing of trusses. A seal on this drawing or cover page listing this drawing, indicates acceptance of professional engineering responsibility solely for the design shown. The suitability and use of this drawing for any structure is the responsibility of the Building Designer per ANSI/TPI 1 Sec.2.  
For more information see these web sites: Alpine: alpineitw.com; TPI: tpinst.org; SBCA: sbccomponents.com; ICC: iccsafe.org; AWC: awc.org



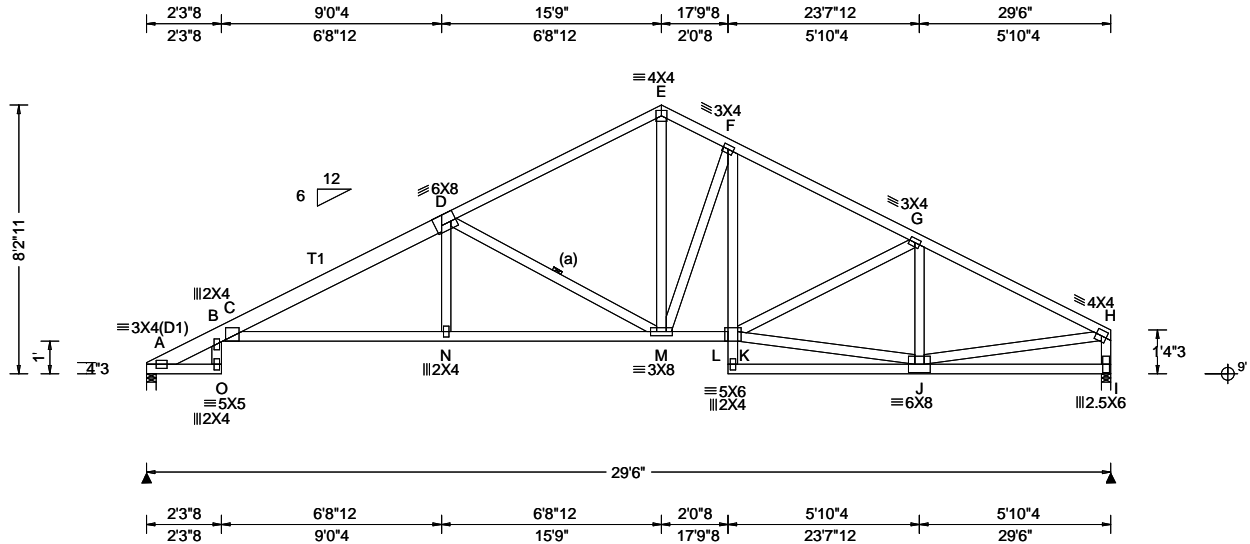

<b>Loading Criteria (psf)</b> TCLL: 20.00 TCCL: 10.00 BCLL: 0.00 BCDL: 10.00 Des Ld: 40.00 NCBCLL: 10.00 Soffit: 2.00 Load Duration: 1.25 Spacing: 24.0 "	<b>Wind Criteria</b> Wind Std: ASCE 7-22 Speed: 130 mph Enclosure: Closed Risk Category: II EXP: C Kzt: NA Mean Height: 15.00 ft TCCL: 4.2 psf BCDL: 3.0 psf MWFRS Parallel Dist: h to 2h C&C Dist a: 3.00 ft Loc. from endwall: not in 9.00 ft GCp: 0.18 Wind Duration: 1.60	<b>Snow Criteria (Pg,Pf in PSF)</b> Pg: NA Ct: NA CAT: NA Pf: NA Ce: NA Lu: NA Cs: NA Snow Duration: NA Building Code: FBC 8th Ed. 2023 Res. TPI Std: 2014 Rep Fac: Yes FT/RT:20(0)/10(0) Plate Type(s): WAVE	<b>Defl/CSI Criteria</b> PP Deflection in loc L/defl L/# VERT(LL): 0.433 C 813 240 VERT(CL): 0.892 C 395 180 HORZ(LL): 0.278 I - - HORZ(TL): 0.573 I - - Creep Factor: 2.0 Max TC CSI: 0.933 Max BC CSI: 0.843 Max Web CSI: 0.567 VIEW Ver: 24.02.00D.0114.10	<b>▲ Maximum Reactions (lbs)</b> <table style="width:100%; border-collapse: collapse;"> <thead> <tr> <th rowspan="2">Loc</th> <th colspan="3">Gravity</th> <th colspan="3">Non-Gravity</th> </tr> <tr> <th>R+</th> <th>/R-</th> <th>/Rh</th> <th>/Rw</th> <th>/U</th> <th>/RL</th> </tr> </thead> <tbody> <tr> <td>A</td> <td>1221</td> <td>-</td> <td>-</td> <td>711</td> <td>107</td> <td>202</td> </tr> <tr> <td>I</td> <td>1209</td> <td>-</td> <td>-</td> <td>681</td> <td>106</td> <td>-</td> </tr> </tbody> </table> <p>Wind reactions based on MWFRS          A Brg Wid = 3.5 Min Req = 1.5 (Truss)          I Brg Wid = 3.5 Min Req = 1.5 (Truss)          Bearings A &amp; I are a rigid surface.          Members not listed have forces less than 375#</p> <b>Maximum Top Chord Forces Per Ply (lbs)</b> <table style="width:100%; border-collapse: collapse;"> <thead> <tr> <th>Chords</th> <th>Tens.Comp.</th> <th>Chords</th> <th>Tens. Comp.</th> </tr> </thead> <tbody> <tr> <td>A - B</td> <td>169 -566</td> <td>E - F</td> <td>558 -1478</td> </tr> <tr> <td>B - C</td> <td>156 -469</td> <td>F - G</td> <td>579 -1766</td> </tr> <tr> <td>C - D</td> <td>695 -2439</td> <td>G - H</td> <td>506 -1741</td> </tr> <tr> <td>D - E</td> <td>533 -1573</td> <td></td> <td></td> </tr> </tbody> </table>	Loc	Gravity			Non-Gravity			R+	/R-	/Rh	/Rw	/U	/RL	A	1221	-	-	711	107	202	I	1209	-	-	681	106	-	Chords	Tens.Comp.	Chords	Tens. Comp.	A - B	169 -566	E - F	558 -1478	B - C	156 -469	F - G	579 -1766	C - D	695 -2439	G - H	506 -1741	D - E	533 -1573		
Loc	Gravity			Non-Gravity																																															
	R+	/R-	/Rh	/Rw	/U	/RL																																													
A	1221	-	-	711	107	202																																													
I	1209	-	-	681	106	-																																													
Chords	Tens.Comp.	Chords	Tens. Comp.																																																
A - B	169 -566	E - F	558 -1478																																																
B - C	156 -469	F - G	579 -1766																																																
C - D	695 -2439	G - H	506 -1741																																																
D - E	533 -1573																																																		

**Lumber**  
 Top chord: 2x4 SP #2; T1 2x6 SP 2400f-2.0E;  
 Bot chord: 2x4 SP #2;  
 Webs: 2x4 SP #3;

**Bracing**  
 (a) Continuous lateral restraint equally spaced on member.

**Wind**  
 Wind loads based on MWFRS with additional C&C member design.  
 Right end vertical not exposed to wind pressure.  
 Wind loading based on both gable and hip roof types.

**Additional Notes**  
 The overall height of this truss excluding overhang is 8-2-11.

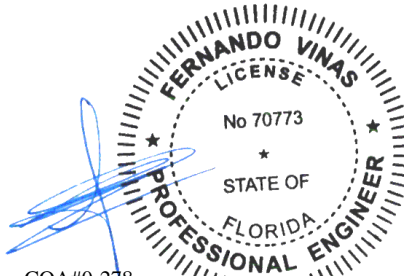

COA#0-278  
 Florida Certificate of Product Approval #FL1999  
 09/10/2025

**\*\*WARNING\*\* READ AND FOLLOW ALL NOTES ON THIS DRAWING!**  
**\*\*IMPORTANT\*\* FURNISH THIS DRAWING TO ALL CONTRACTORS INCLUDING THE INSTALLERS**  
 Trusses require extreme care in fabricating, handling, shipping, installing and bracing. Refer to and follow the latest edition of BCSI (Building Component Safety Information, by TPI and SBCA) for safety practices prior to performing these functions. Installers shall provide temporary bracing per BCSI. Unless noted otherwise, top chord shall have properly attached structural sheathing and bottom chord shall have a properly attached rigid ceiling. Locations shown for permanent lateral restraint of webs shall have continuous lateral restraint (CLR), installed with diagonal bracing installed on the CLR per BCSI sections B3, B7, or B10, as applicable. Apply plates to each face of truss and position as shown above and on the Joint Details, unless noted otherwise. Refer to drawings 160A-Z for standard plate positions. Refer to job's General Notes page for additional information.  
 Alpine, a division of ITW Building Components Group Inc. shall not be responsible for any deviation from this drawing, any failure to build the truss in conformance with ANSI/TPI 1, or for handling, shipping, installation and bracing of trusses. A seal on this drawing or cover page listing this drawing, indicates acceptance of professional engineering responsibility solely for the design shown. The suitability and use of this drawing for any structure is the responsibility of the Building Designer per ANSI/TPI 1 Sec.2.  
 For more information see these web sites: Alpine: alpineitw.com; TPI: tpinst.org; SBCA: sbccomponents.com; ICC: iccsafe.org; AWC: awc.org



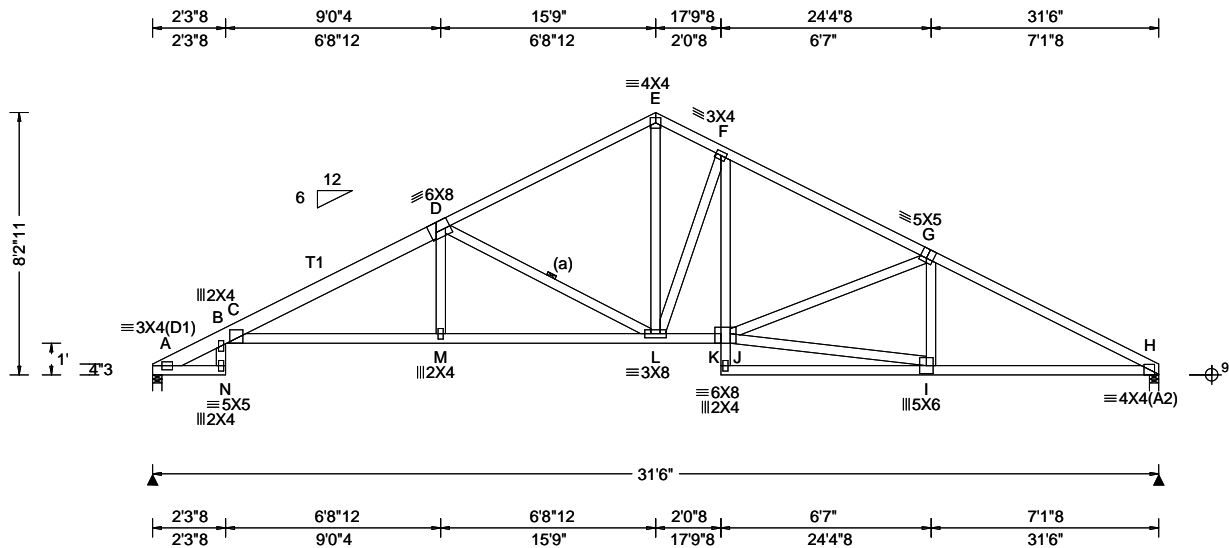

<b>Loading Criteria</b> (psf) TCLL: 20.00 TCDL: 10.00 BCLL: 0.00 BCDL: 10.00 Des Ld: 40.00 NCBCLL: 10.00 Soffit: 2.00 Load Duration: 1.25 Spacing: 24.0 "	<b>Wind Criteria</b> Wind Std: ASCE 7-22 Speed: 130 mph Enclosure: Closed Risk Category: II EXP: C Kzt: NA Mean Height: 15.00 ft TCDL: 4.2 psf BCDL: 3.0 psf MWFRS Parallel Dist: h to 2h C&C Dist a: 3.15 ft Loc. from endwall: not in 9.00 ft GCp: 0.18 Wind Duration: 1.60	<b>Snow Criteria</b> (Pg,Pf in PSF) Pg: NA Ct: NA CAT: NA Pf: NA Ce: NA Lu: NA Cs: NA Snow Duration: NA  Building Code: FBC 8th Ed. 2023 Res. TPI Std: 2014 Rep Fac: Yes FT/RT:20(0)/10(0) Plate Type(s): WAVE	<b>Defl/CSI Criteria</b> PP Deflection in loc L/defl L/# VERT(LL): 0.459 C 815 240 VERT(CL): 0.946 C 395 180 HORZ(LL): 0.307 H - - HORZ(TL): 0.632 H - - Creep Factor: 2.0 Max TC CSI: 0.997 Max BC CSI: 0.868 Max Web CSI: 0.754  VIEW Ver: 24.02.00D.0114.10	<b>▲ Maximum Reactions (lbs)</b> Gravity Non-Gravity Loc R+ / R- / Rh / Rw / U / RL A 1296 /- /- /749 /112 /203 H 1294 /- /- /752 /113 /- Wind reactions based on MWFRS A Brg Wid = 3.5 Min Req = 1.5 (Truss) H Brg Wid = 3.5 Min Req = 1.5 (Truss) Bearings A & H are a rigid surface. Members not listed have forces less than 375# <b>Maximum Top Chord Forces Per Ply (lbs)</b> Chords Tens.Comp. Chords Tens. Comp. A - B 214 -604 E - F 616 -1678 B - C 200 -502 F - G 648 -2043 C - D 756 -2669 G - H 670 -2335 D - E 584 -1767
--	--	--	---	---

**Lumber**  
Top chord: 2x4 SP #2; T1 2x6 SP 2400f-2.0E;  
Bot chord: 2x4 SP #2;  
Webs: 2x4 SP #3;

**Bracing**  
(a) Continuous lateral restraint equally spaced on member.

**Wind**  
Wind loads based on MWFRS with additional C&C member design.  
Wind loading based on both gable and hip roof types.

**Additional Notes**  
The overall height of this truss excluding overhang is 8-2-11.

<b>Maximum Bot Chord Forces Per Ply (lbs)</b>			
Chords	Tens.Comp.	Chords	Tens. Comp.
C - M	2500 -643	L - J	1742 -373
M - L	2501 -640	I - H	2011 -522
<b>Maximum Web Forces Per Ply (lbs)</b>			
Webs	Tens.Comp.	Webs	Tens. Comp.
D - L	398 -1149	F - J	620 -159
E - L	1248 -401	J - I	1979 -518
L - F	306 -784		

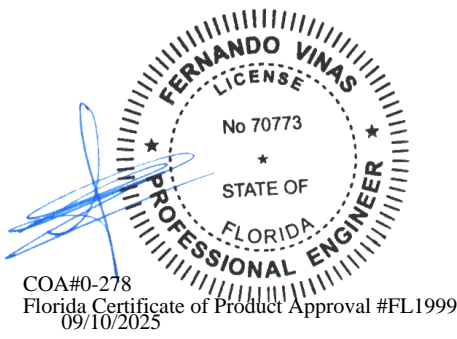

**\*\*WARNING\*\* READ AND FOLLOW ALL NOTES ON THIS DRAWING!**  
**\*\*IMPORTANT\*\* FURNISH THIS DRAWING TO ALL CONTRACTORS INCLUDING THE INSTALLERS**  
Trusses require extreme care in fabricating, handling, shipping, installing and bracing. Refer to and follow the latest edition of BCSI (Building Component Safety Information, by TPI and SBCA) for safety practices prior to performing these functions. Installers shall provide temporary bracing per BCSI. Unless noted otherwise, top chord shall have properly attached structural sheathing and bottom chord shall have a properly attached rigid ceiling. Locations shown for permanent lateral restraint of webs shall have continuous lateral restraint (CLR), installed with diagonal bracing installed on the CLR per BCSI sections B3, B7, or B10, as applicable. Apply plates to each face of truss and position as shown above and on the Joint Details, unless noted otherwise. Refer to drawings 160A-Z for standard plate positions. Refer to job's General Notes page for additional information.  
Alpine, a division of ITW Building Components Group Inc. shall not be responsible for any deviation from this drawing, any failure to build the truss in conformance with ANSI/TPI 1, or for handling, shipping, installation and bracing of trusses. A seal on this drawing or cover page listing this drawing, indicates acceptance of professional engineering responsibility solely for the design shown. The suitability and use of this drawing for any structure is the responsibility of the Building Designer per ANSI/TPI 1 Sec.2.  
For more information see these web sites: Alpine: alpineitw.com; TPI: tpinst.org; SBCA: sbcacomponents.com; ICC: iccsafe.org; AWC: awc.org



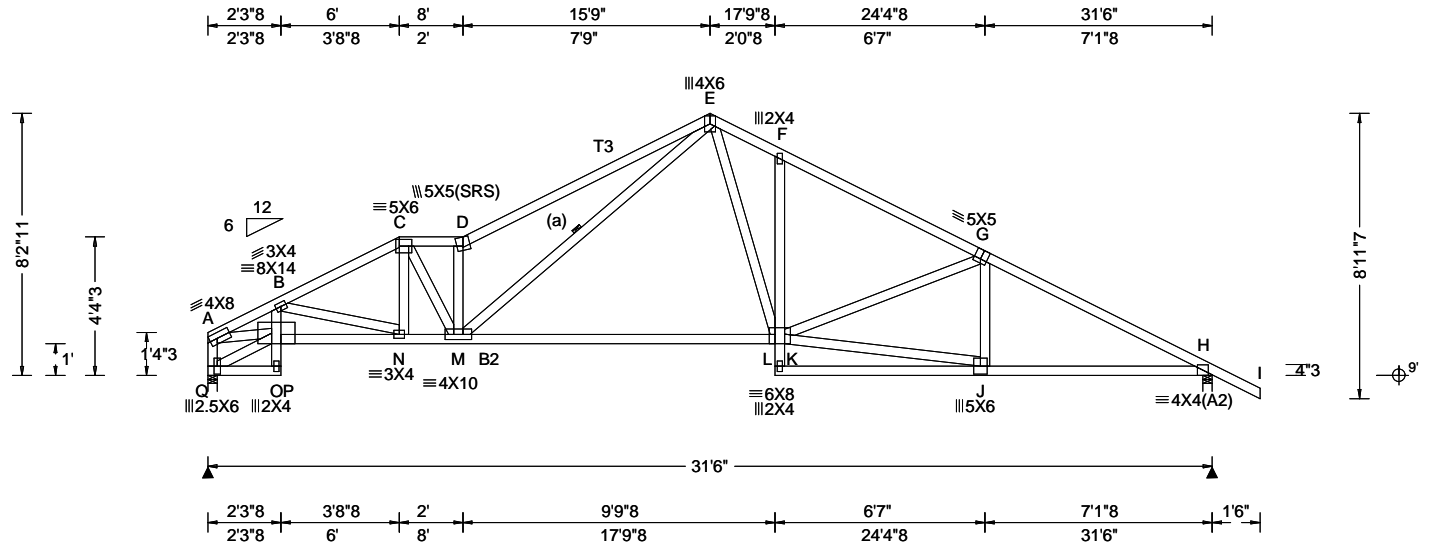

<b>Loading Criteria (psf)</b> TCLL: 20.00 TCDL: 10.00 BCLL: 0.00 BCDL: 10.00 Des Ld: 40.00 NCBCLL: 10.00 Soffit: 2.00 Load Duration: 1.25 Spacing: 24.0 "	<b>Wind Criteria</b> Wind Std: ASCE 7-22 Speed: 130 mph Enclosure: Closed Risk Category: II EXP: C Kzt: NA Mean Height: 15.00 ft TCDL: 4.2 psf BCDL: 3.0 psf MWFRS Parallel Dist: h to 2h C&C Dist a: 3.15 ft Loc. from endwall: not in 9.00 ft GCp: 0.18 Wind Duration: 1.60	<b>Snow Criteria (Pg,Pf in PSF)</b> Pg: NA Ct: NA CAT: NA Pf: NA Ce: NA Lu: NA Cs: NA Snow Duration: NA  Building Code: FBC 8th Ed. 2023 Res. TPI Std: 2014 Rep Fac: Yes FT/RT:20(0)/10(0) Plate Type(s): WAVE	<b>Defl/CSI Criteria</b> PP Deflection in loc L/defl L/# VERT(LL): 0.163 D 999 240 VERT(CL): 0.332 D 999 180 HORZ(LL): 0.084 H - - HORZ(TL): 0.171 H - - Creep Factor: 2.0 Max TC CSI: 0.625 Max BC CSI: 0.648 Max Web CSI: 0.997  VIEW Ver: 24.02.00D.0114.10	<b>▲ Maximum Reactions (lbs)</b> Gravity Non-Gravity Loc R+ /R- /Rh /Rw /U /RL Q 1287 /- /- /725 /114 /218 H 1403 /- /- /765 /136 /- Wind reactions based on MWFRS Q Brg Wid = 3.5 Min Req = 1.5 (Truss) H Brg Wid = 3.5 Min Req = 1.7 (Truss) Bearings Q & H are a rigid surface. Members not listed have forces less than 375# <b>Maximum Top Chord Forces Per Ply (lbs)</b> Chords Tens.Comp. Chords Tens. Comp. A - B 1000 -2966 E - F 746 -1975 B - C 832 -2360 F - G 691 -2059 C - D 916 -2583 G - H 702 -2323 D - E 1161 -3080
--	--	--	---	--

**Lumber**

Top chord: 2x4 SP #2; T3 2x4 SP M-31;  
Bot chord: 2x4 SP #2; B2 2x4 SP M-31;  
Webs: 2x4 SP #3;

**Bracing**

(a) Continuous lateral restraint equally spaced on member.

**Purlins**

In lieu of structural panels use purlins to brace all flat TC @ 24" oc.

**Wind**

Wind loads based on MWFRS with additional C&C member design.  
Left end vertical not exposed to wind pressure.  
Wind loading based on both gable and hip roof types.

**Additional Notes**

The overall height of this truss excluding overhang is 8-2-11.

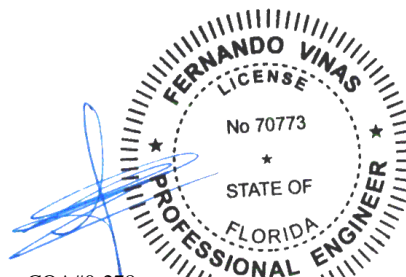

COA#0-278  
Florida Certificate of Product Approval #FL1999  
09/10/2025

**\*\*WARNING\*\* READ AND FOLLOW ALL NOTES ON THIS DRAWING!**  
**\*\*IMPORTANT\*\* FURNISH THIS DRAWING TO ALL CONTRACTORS INCLUDING THE INSTALLERS**  
Trusses require extreme care in fabricating, handling, shipping, installing and bracing. Refer to and follow the latest edition of BCSI (Building Component Safety Information, by TPI and SBCA) for safety practices prior to performing these functions. Installers shall provide temporary bracing per BCSI. Unless noted otherwise, top chord shall have properly attached structural sheathing and bottom chord shall have a properly attached rigid ceiling. Locations shown for permanent lateral restraint of webs shall have continuous lateral restraint (CLR), installed with diagonal bracing installed on the CLR per BCSI sections B3, B7, or B10, as applicable. Apply plates to each face of truss and position as shown above and on the Joint Details, unless noted otherwise. Refer to drawings 160A-Z for standard plate positions. Refer to job's General Notes page for additional information.  
Alpine, a division of ITW Building Components Group Inc. shall not be responsible for any deviation from this drawing, any failure to build the truss in conformance with ANSI/TPI 1, or for handling, shipping, installation and bracing of trusses. A seal on this drawing or cover page listing this drawing, indicates acceptance of professional engineering responsibility solely for the design shown. The suitability and use of this drawing for any structure is the responsibility of the Building Designer per ANSI/TPI 1 Sec.2.  
For more information see these web sites: Alpine: [alpineitw.com](http://alpineitw.com); TPI: [tpinst.org](http://tpinst.org); SBCA: [sbcacomponents.com](http://sbcacomponents.com); ICC: [iccsafe.org](http://iccsafe.org); AWC: [awc.org](http://awc.org)



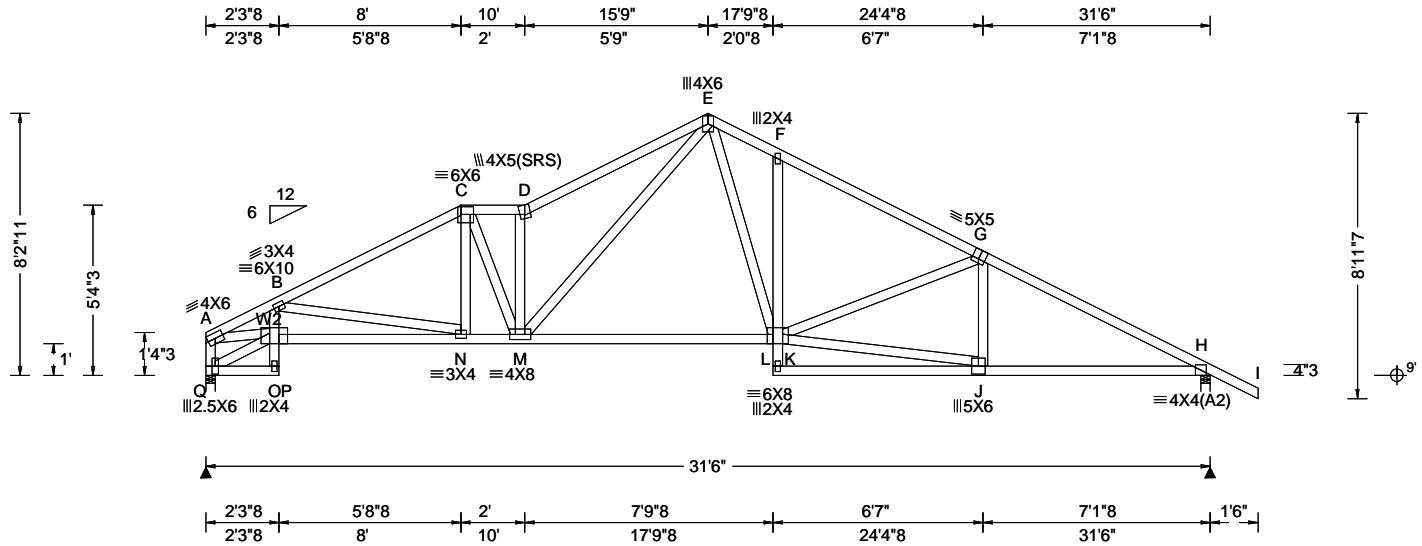

<b>Loading Criteria (psf)</b> TCLL: 20.00 TCDL: 10.00 BCLL: 0.00 BCDL: 10.00 Des Ld: 40.00 NCBCLL: 10.00 Soffit: 2.00 Load Duration: 1.25 Spacing: 24.0 "	<b>Wind Criteria</b> Wind Std: ASCE 7-22 Speed: 130 mph Enclosure: Closed Risk Category: II EXP: C Kzt: NA Mean Height: 15.00 ft TCDL: 4.2 psf BCDL: 3.0 psf MWFRS Parallel Dist: h to 2h C&C Dist a: 3.15 ft Loc. from endwall: not in 9.00 ft GCpi: 0.18 Wind Duration: 1.60	<b>Snow Criteria (Pg,Pf in PSF)</b> Pg: NA Ct: NA CAT: NA Pf: NA Ce: NA Lu: NA Cs: NA Snow Duration: NA  Building Code: FBC 8th Ed. 2023 Res. TPI Std: 2014 Rep Fac: Yes FT/RT:20(0)/10(0) Plate Type(s): WAVE	<b>Defl/CSI Criteria</b> PP Deflection in loc L/defl L/# VERT(LL): 0.159 D 999 240 VERT(CL): 0.325 D 999 180 HORZ(LL): 0.098 H - - HORZ(TL): 0.200 H - - Creep Factor: 2.0 Max TC CSI: 0.562 Max BC CSI: 0.797 Max Web CSI: 0.816  VIEW Ver: 24.02.00D.0114.10	<b>▲ Maximum Reactions (lbs)</b> Gravity Non-Gravity Loc R+ /R- /Rh /Rw /U /RL Q 1287 -/- /726 /114 /218 H 1403 -/- /766 /138 -/ Wind reactions based on MWFRS Q Brg Wid = 3.5 Min Req = 1.5 (Truss) H Brg Wid = 3.5 Min Req = 1.7 (Truss) Bearings Q & H are a rigid surface. Members not listed have forces less than 375# <b>Maximum Top Chord Forces Per Ply (lbs)</b> Chords Tens.Comp. Chords Tens. Comp. A - B 1026 -3037 E - F 781 -1995 B - C 792 -2247 F - G 712 -2057 C - D 828 -2188 G - H 717 -2323 D - E 1022 -2573
--	---	--	---	--

**Lumber**  
Top chord: 2x4 SP #2;  
Bot chord: 2x4 SP #2;  
Webs: 2x4 SP #3; W2 2x4 SP #2;

**Purlins**  
In lieu of structural panels use purlins to brace all flat TC @ 24" oc.

**Wind**  
Wind loads based on MWFRS with additional C&C member design.  
Left end vertical not exposed to wind pressure.  
Wind loading based on both gable and hip roof types.

**Additional Notes**  
The overall height of this truss excluding overhang is 8-2-11.

<b>Maximum Bot Chord Forces Per Ply (lbs)</b>			
Chords	Tens.Comp.	Chords	Tens. Comp.
O - N	2793 -903	M - K	1487 -309
N - M	1942 -565	J - H	1996 -517
<b>Maximum Web Forces Per Ply (lbs)</b>			
Webs	Tens.Comp.	Webs	Tens. Comp.
A - Q	398 -1218	M - D	578 -1311
A - O	2696 -909	M - E	1156 -517
B - N	344 -865	E - K	888 -310
C - M	591 -171	K - J	1987 -508

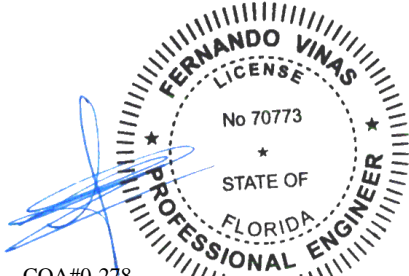

COA#0-278  
Florida Certificate of Product Approval #FL1999  
09/10/2025

**\*\*WARNING\*\* READ AND FOLLOW ALL NOTES ON THIS DRAWING!**  
**\*\*IMPORTANT\*\* FURNISH THIS DRAWING TO ALL CONTRACTORS INCLUDING THE INSTALLERS**  
Trusses require extreme care in fabricating, handling, shipping, installing and bracing. Refer to and follow the latest edition of BCSI (Building Component Safety Information, by TPI and SBCA) for safety practices prior to performing these functions. Installers shall provide temporary bracing per BCSI. Unless noted otherwise, top chord shall have properly attached structural sheathing and bottom chord shall have a properly attached rigid ceiling. Locations shown for permanent lateral restraint of webs shall have continuous lateral restraint (CLR), installed with diagonal bracing installed on the CLR per BCSI sections B3, B7, or B10, as applicable. Apply plates to each face of truss and position as shown above and on the Joint Details, unless noted otherwise. Refer to drawings 160A-Z for standard plate positions. Refer to job's General Notes page for additional information.  
Alpine, a division of ITW Building Components Group Inc. shall not be responsible for any deviation from this drawing, any failure to build the truss in conformance with ANSI/TPI 1, or for handling, shipping, installation and bracing of trusses. A seal on this drawing or cover page listing this drawing, indicates acceptance of professional engineering responsibility solely for the design shown. The suitability and use of this drawing for any structure is the responsibility of the Building Designer per ANSI/TPI 1 Sec.2.  
For more information see these web sites: Alpine: [alpineitw.com](http://alpineitw.com); TPI: [tpinst.org](http://tpinst.org); SBCA: [sbcacomponents.com](http://sbcacomponents.com); ICC: [iccsafe.org](http://iccsafe.org); AWC: [awc.org](http://awc.org)



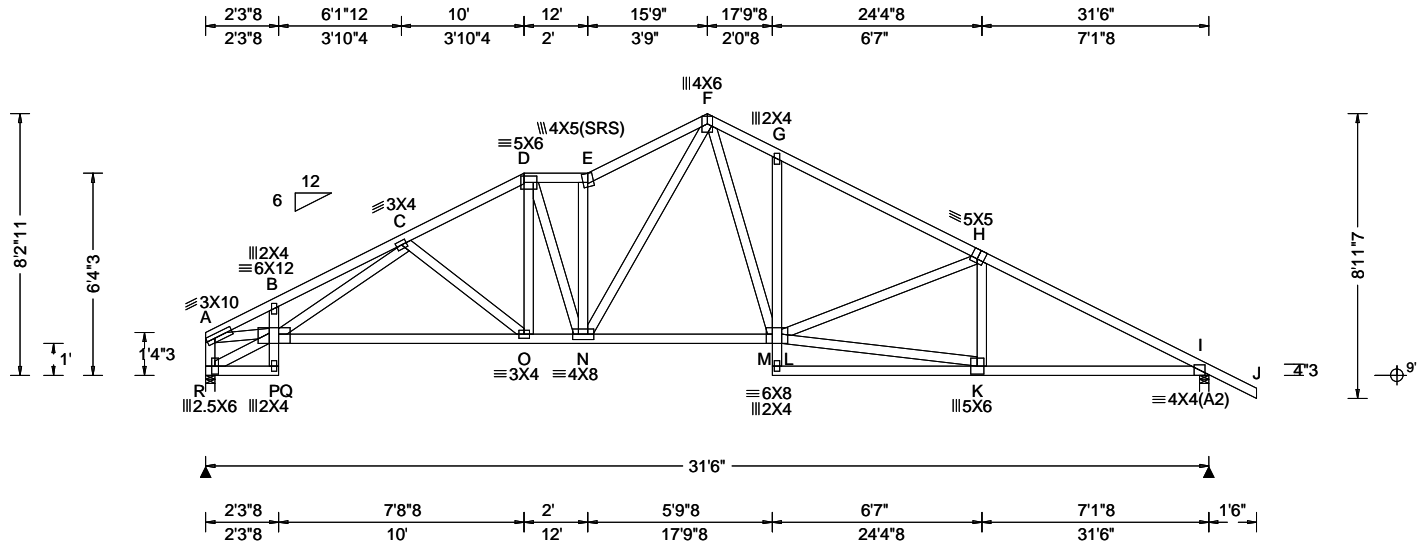

<b>Loading Criteria (psf)</b> TCLL: 20.00 TCDL: 10.00 BCLL: 0.00 BCDL: 10.00 Des Ld: 40.00 NCBCLL: 10.00 Soffit: 2.00 Load Duration: 1.25 Spacing: 24.0 "	<b>Wind Criteria</b> Wind Std: ASCE 7-22 Speed: 130 mph Enclosure: Closed Risk Category: II EXP: C Kzt: NA Mean Height: 15.00 ft TCDL: 4.2 psf BCDL: 3.0 psf MWFRS Parallel Dist: > 2h C&C Dist a: 3.15 ft Loc. from endwall: not in 9.00 ft GCp: 0.18 Wind Duration: 1.60	<b>Snow Criteria (Pg,Pf in PSF)</b> Pg: NA Ct: NA CAT: NA Pf: NA Ce: NA Lu: NA Cs: NA Snow Duration: NA  Building Code: FBC 8th Ed. 2023 Res. TPI Std: 2014 Rep Fac: Yes FT/RT:20(0)/10(0) Plate Type(s): WAVE	<b>Defl/CSI Criteria</b> PP Deflection in loc L/defl L/# VERT(LL): 0.146 E 999 240 VERT(CL): 0.298 E 999 180 HORZ(LL): 0.093 I - - HORZ(TL): 0.189 I - - Creep Factor: 2.0 Max TC CSI: 0.496 Max BC CSI: 0.836 Max Web CSI: 0.975  VIEW Ver: 24.02.00D.0114.10	<b>▲ Maximum Reactions (lbs)</b> Gravity Non-Gravity Loc R+ / R- / Rh / Rw / U / RL R 1287 -/ - /728 /106 /218 I 1403 -/ - /768 /141 -/ Wind reactions based on MWFRS R Brg Wid = 3.5 Min Req = 1.5 (Truss) I Brg Wid = 3.5 Min Req = 1.7 (Truss) Bearings R & I are a rigid surface. Members not listed have forces less than 375# <b>Maximum Top Chord Forces Per Ply (lbs)</b> Chords Tens.Comp. Chords Tens. Comp. A - B 923 -2911 E - F 916 -2188 B - C 1006 -3027 F - G 814 -2009 C - D 759 -2038 G - H 733 -2056 D - E 757 -1887 H - I 733 -2322  <b>Maximum Bot Chord Forces Per Ply (lbs)</b> Chords Tens.Comp. Chords Tens. Comp. P - O 2109 -655 N - L 1477 -317 O - N 1766 -478 K - I 1996 -531  <b>Maximum Web Forces Per Ply (lbs)</b> Webs Tens.Comp. Webs Tens. Comp. A - R 392 -1224 N - E 516 -1099 A - P 2560 -801 N - F 903 -439 P - C 702 -235 F - L 916 -340 C - O 225 -434 L - K 1977 -524 D - O 393 -87
--	---	--	---	---

**Lumber**

Top chord: 2x4 SP #2;  
Bot chord: 2x4 SP #2;  
Webs: 2x4 SP #3;

**Purlins**

In lieu of structural panels use purlins to brace all flat TC @ 24" oc.

**Wind**

Wind loads based on MWFRS with additional C&C member design.  
Left end vertical not exposed to wind pressure.  
Wind loading based on both gable and hip roof types.

**Additional Notes**

The overall height of this truss excluding overhang is 8-2-11.

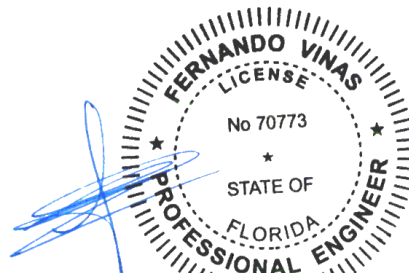

COA#0-278  
Florida Certificate of Product Approval #FL1999  
09/10/2025

**\*\*WARNING\*\* READ AND FOLLOW ALL NOTES ON THIS DRAWING!**  
**\*\*IMPORTANT\*\* FURNISH THIS DRAWING TO ALL CONTRACTORS INCLUDING THE INSTALLERS**  
Trusses require extreme care in fabricating, handling, shipping, installing and bracing. Refer to and follow the latest edition of BCSI (Building Component Safety Information, by TPI and SBCA) for safety practices prior to performing these functions. Installers shall provide temporary bracing per BCSI. Unless noted otherwise, top chord shall have properly attached structural sheathing and bottom chord shall have a properly attached rigid ceiling. Locations shown for permanent lateral restraint of webs shall have continuous lateral restraint (CLR), installed with diagonal bracing installed on the CLR per BCSI sections B3, B7, or B10, as applicable. Apply plates to each face of truss and position as shown above and on the Joint Details, unless noted otherwise. Refer to drawings 160A-Z for standard plate positions. Refer to job's General Notes page for additional information.  
Alpine, a division of ITW Building Components Group Inc. shall not be responsible for any deviation from this drawing, any failure to build the truss in conformance with ANSI/TPI 1, or for handling, shipping, installation and bracing of trusses. A seal on this drawing or cover page listing this drawing, indicates acceptance of professional engineering responsibility solely for the design shown. The suitability and use of this drawing for any structure is the responsibility of the Building Designer per ANSI/TPI 1 Sec.2.  
For more information see these web sites: Alpine: alpineitw.com; TPI: tpinst.org; SBCA: sbcacomponents.com; ICC: iccsafe.org; AWC: awc.org



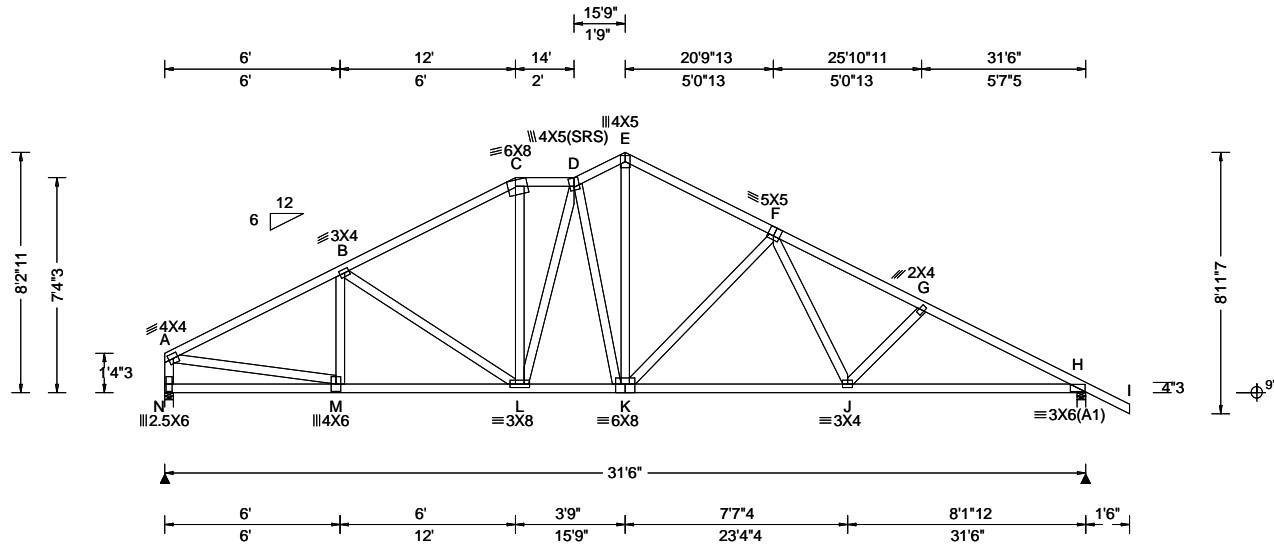

<b>Loading Criteria (psf)</b> TCLL: 20.00 TCDL: 10.00 BCLL: 0.00 BCDL: 10.00 Des Ld: 40.00 NCBCLL: 10.00 Soffit: 2.00 Load Duration: 1.25 Spacing: 24.0 "	<b>Wind Criteria</b> Wind Std: ASCE 7-22 Speed: 130 mph Enclosure: Closed Risk Category: II EXP: C Kzt: NA Mean Height: 15.00 ft TCDL: 4.2 psf BCDL: 3.0 psf MWFRS Parallel Dist: > 2h C&C Dist a: 3.15 ft Loc. from endwall: not in 9.00 ft GCp: 0.18 Wind Duration: 1.60	<b>Snow Criteria (Pg,Pf in PSF)</b> Pg: NA Ct: NA CAT: NA Pf: NA Ce: NA Lu: NA Cs: NA Snow Duration: NA  Building Code: FBC 8th Ed. 2023 Res. TPI Std: 2014 Rep Fac: Yes FT/RT:20(0)/10(0) Plate Type(s): WAVE	<b>Defl/CSI Criteria</b> PP Deflection in loc L/defl L/# VERT(LL): 0.114 K 999 240 VERT(CL): 0.202 F 999 180 HORZ(LL): 0.041 H - - HORZ(TL): 0.072 H - - Creep Factor: 2.0 Max TC CSI: 0.484 Max BC CSI: 0.746 Max Web CSI: 0.601  VIEW Ver: 24.02.00D.0114.10	<b>▲ Maximum Reactions (lbs)</b> Gravity Non-Gravity Loc R+ / R- / Rh / Rw / U / RL N 1288 - / - / 730 / 107 / 218 H 1406 - / - / 769 / 143 - Wind reactions based on MWFRS N Brg Wid = 3.5 Min Req = 1.5 (Truss) H Brg Wid = 3.5 Min Req = 1.7 (Truss) Bearings N & H are a rigid surface. Members not listed have forces less than 375# <b>Maximum Top Chord Forces Per Ply (lbs)</b> Chords Tens.Comp. Chords Tens. Comp. A - B 613 - 1868 E - F 625 - 1522 B - C 628 - 1622 F - G 724 - 2144 C - D 619 - 1376 G - H 748 - 2364 D - E 623 - 1431  <b>Maximum Bot Chord Forces Per Ply (lbs)</b> Chords Tens.Comp. Chords Tens. Comp. M - L 1615 - 453 K - J 1689 - 421 L - K 1411 - 332 J - H 2048 - 558  <b>Maximum Web Forces Per Ply (lbs)</b> Webs Tens.Comp. Webs Tens. Comp. A - N 420 - 1238 E - K 994 - 411 A - M 1579 - 479 K - F 247 - 569 C - L 397 - 102 F - J 452 - 74 D - K 286 - 480
--	---	--	---	---

**Lumber**

Top chord: 2x4 SP #2;  
Bot chord: 2x4 SP #2;  
Webs: 2x4 SP #3;

**Purlins**

In lieu of structural panels use purlins to brace all flat TC @ 24" oc.

**Wind**

Wind loads based on MWFRS with additional C&C member design.  
Left end vertical not exposed to wind pressure.  
Wind loading based on both gable and hip roof types.

**Additional Notes**

The overall height of this truss excluding overhang is 8-2-11.

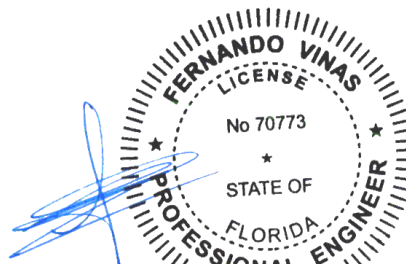

COA#0-278  
Florida Certificate of Product Approval #FL1999  
09/10/2025

**\*\*WARNING\*\* READ AND FOLLOW ALL NOTES ON THIS DRAWING!**  
**\*\*IMPORTANT\*\* FURNISH THIS DRAWING TO ALL CONTRACTORS INCLUDING THE INSTALLERS**  
Trusses require extreme care in fabricating, handling, shipping, installing and bracing. Refer to and follow the latest edition of BCSI (Building Component Safety Information, by TPI and SBCA) for safety practices prior to performing these functions. Installers shall provide temporary bracing per BCSI. Unless noted otherwise, top chord shall have properly attached structural sheathing and bottom chord shall have a properly attached rigid ceiling. Locations shown for permanent lateral restraint of webs shall have continuous lateral restraint (CLR), installed with diagonal bracing installed on the CLR per BCSI sections B3, B7, or B10, as applicable. Apply plates to each face of truss and position as shown above and on the Joint Details, unless noted otherwise. Refer to drawings 160A-Z for standard plate positions. Refer to job's General Notes page for additional information.  
Alpine, a division of ITW Building Components Group Inc. shall not be responsible for any deviation from this drawing, any failure to build the truss in conformance with ANSI/TPI 1, or for handling, shipping, installation and bracing of trusses. A seal on this drawing or cover page listing this drawing, indicates acceptance of professional engineering responsibility solely for the design shown. The suitability and use of this drawing for any structure is the responsibility of the Building Designer per ANSI/TPI 1 Sec.2.  
For more information see these web sites: Alpine: alpineitw.com; TPI: tpinst.org; SBCA: sbccomponents.com; ICC: iccsafe.org; AWC: awc.org



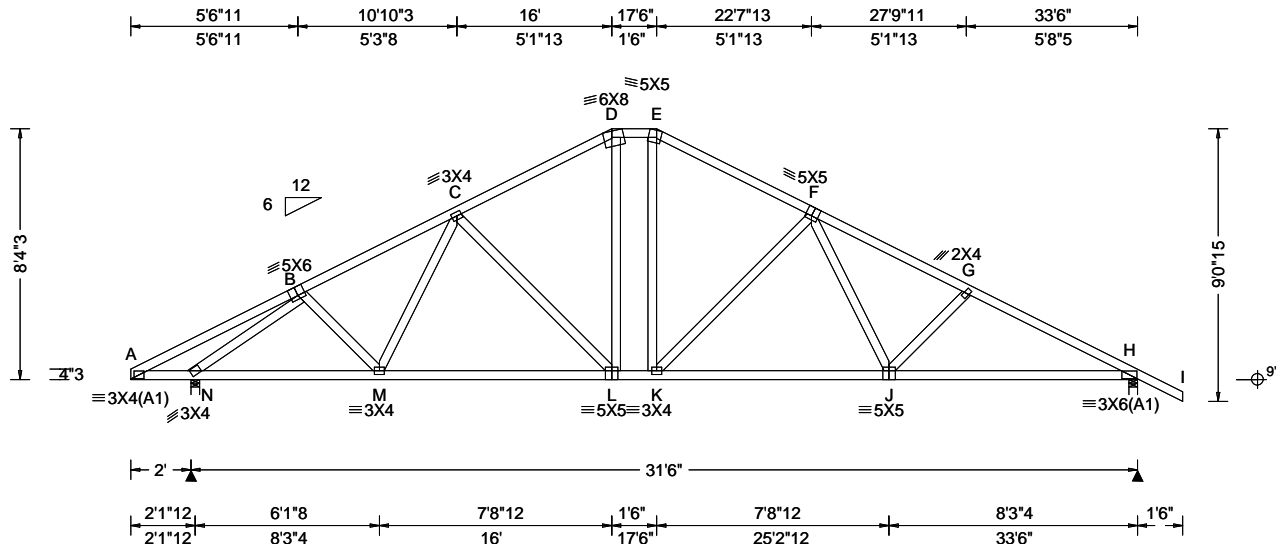

<b>Loading Criteria (psf)</b> TCLL: 20.00 TCDL: 10.00 BCLL: 0.00 BCDL: 10.00 Des Ld: 40.00 NCBCLL: 10.00 Soffit: 2.00 Load Duration: 1.25 Spacing: 24.0 "	<b>Wind Criteria</b> Wind Std: ASCE 7-22 Speed: 130 mph Enclosure: Closed Risk Category: II EXP: C Kzt: NA Mean Height: 15.00 ft TCDL: 4.2 psf BCDL: 3.0 psf MWFRS Parallel Dist: h to 2h C&C Dist a: 3.35 ft Loc. from endwall: not in 9.00 ft GCp: 0.18 Wind Duration: 1.60	<b>Snow Criteria (Pg,Pf in PSF)</b> Pg: NA Ct: NA CAT: NA Pf: NA Ce: NA Lu: NA Cs: NA Snow Duration: NA  Building Code: FBC 8th Ed. 2023 Res. TPI Std: 2014 Rep Fac: Yes FT/RT:20(0)/10(0) Plate Type(s): WAVE	<b>Defl/CSI Criteria</b> PP Deflection in loc L/defl L/# VERT(LL): 0.098 F 999 240 VERT(CL): 0.190 K 999 180 HORZ(LL): 0.040 H - - HORZ(TL): 0.083 H - - Creep Factor: 2.0 Max TC CSI: 0.422 Max BC CSI: 0.753 Max Web CSI: 0.920  VIEW Ver: 24.02.00D.0114.10	<b>▲ Maximum Reactions (lbs)</b> Gravity Non-Gravity Loc R+ / R- / Rh / Rw / U / RL N 1465 -/- /- /790 /116 /223 H 1397 -/- /- /770 /131 -/ Wind reactions based on MWFRS N Brg Wid = 3.5 Min Req = 1.5 (Truss) H Brg Wid = 3.5 Min Req = 1.6 (Truss) Bearings N & H are a rigid surface. Members not listed have forces less than 375# <b>Maximum Top Chord Forces Per Ply (lbs)</b> Chords Tens.Comp. Chords Tens. Comp. B - C 584 -1740 E - F 586 -1476 C - D 581 -1470 F - G 689 -2117 D - E 560 -1247 G - H 713 -2341  <b>Maximum Bot Chord Forces Per Ply (lbs)</b> Chords Tens.Comp. Chords Tens. Comp. N - M 1387 -373 K - J 1661 -397 M - L 1478 -357 J - H 2027 -541 L - K 1247 -224  <b>Maximum Web Forces Per Ply (lbs)</b> Webs Tens.Comp. Webs Tens. Comp. N - B 699 -2037 E - K 473 -157 C - L 192 -384 K - F 268 -625 D - L 383 -126 F - J 458 -80
--	--	--	---	--

**Lumber**

Top chord: 2x4 SP #2;  
Bot chord: 2x4 SP #2;  
Webs: 2x4 SP #3;

**Purlins**

In lieu of structural panels use purlins to brace all flat TC @ 24" oc.

**Wind**

Wind loads based on MWFRS with additional C&C member design.  
Left cantilever is exposed to wind  
Wind loading based on both gable and hip roof types.

**Additional Notes**

The overall height of this truss excluding overhang is 8-4-3.

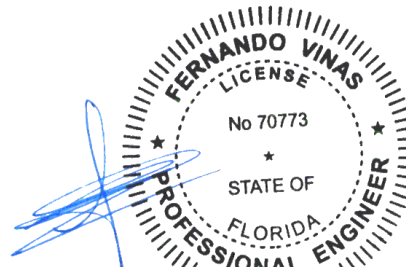

COA#0-278  
Florida Certificate of Product Approval #FL1999  
09/10/2025

**\*\*WARNING\*\* READ AND FOLLOW ALL NOTES ON THIS DRAWING!**  
**\*\*IMPORTANT\*\* FURNISH THIS DRAWING TO ALL CONTRACTORS INCLUDING THE INSTALLERS**  
Trusses require extreme care in fabricating, handling, shipping, installing and bracing. Refer to and follow the latest edition of BCSI (Building Component Safety Information, by TPI and SBCA) for safety practices prior to performing these functions. Installers shall provide temporary bracing per BCSI. Unless noted otherwise, top chord shall have properly attached structural sheathing and bottom chord shall have a properly attached rigid ceiling. Locations shown for permanent lateral restraint of webs shall have continuous lateral restraint (CLR), installed with diagonal bracing installed on the CLR per BCSI sections B3, B7, or B10, as applicable. Apply plates to each face of truss and position as shown above and on the Joint Details, unless noted otherwise. Refer to drawings 160A-Z for standard plate positions. Refer to job's General Notes page for additional information.  
Alpine, a division of ITW Building Components Group Inc. shall not be responsible for any deviation from this drawing, any failure to build the truss in conformance with ANSI/TPI 1, or for handling, shipping, installation and bracing of trusses. A seal on this drawing or cover page listing this drawing, indicates acceptance of professional engineering responsibility solely for the design shown. The suitability and use of this drawing for any structure is the responsibility of the Building Designer per ANSI/TPI 1 Sec.2.  
For more information see these web sites: Alpine: alpineitw.com; TPI: tpinst.org; SBCA: sbccomponents.com; ICC: iccsafe.org; AWC: awc.org



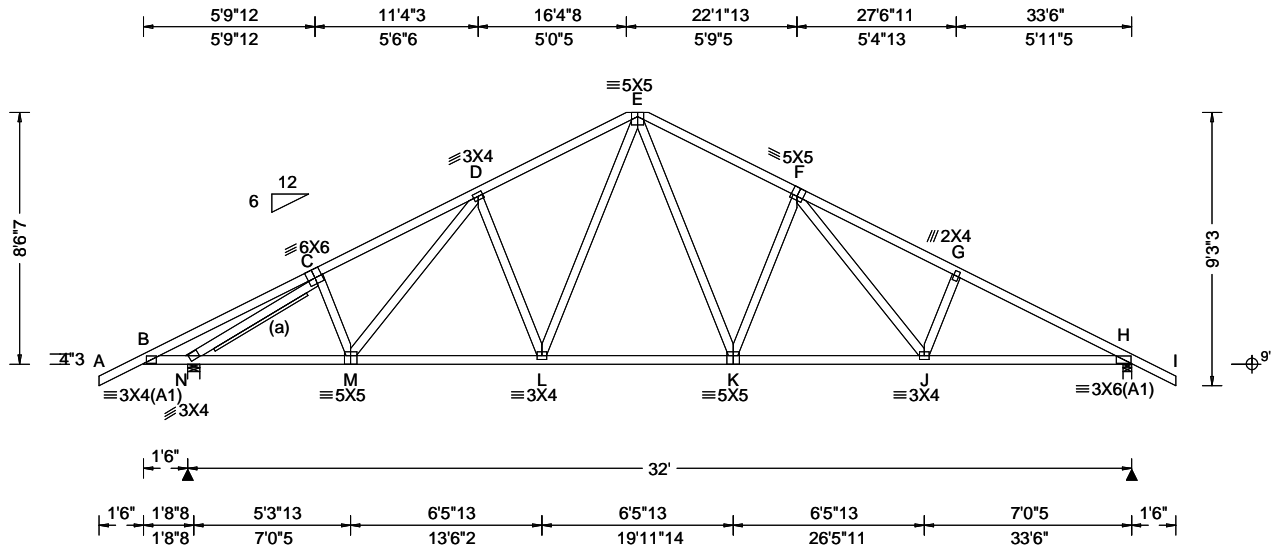

<b>Loading Criteria (psf)</b> TCLL: 20.00 TCDL: 10.00 BCLL: 0.00 BCDL: 10.00 Des Ld: 40.00 NCBCLL: 10.00 Soffit: 2.00 Load Duration: 1.25 Spacing: 24.0 "	<b>Wind Criteria</b> Wind Std: ASCE 7-22 Speed: 130 mph Enclosure: Closed Risk Category: II EXP: C Kzt: NA Mean Height: 15.00 ft TCDL: 4.2 psf BCDL: 3.0 psf MWFRS Parallel Dist: h to 2h C&C Dist a: 3.35 ft Loc. from endwall: not in 9.00 ft GCp: 0.18 Wind Duration: 1.60	<b>Snow Criteria (Pg,Pf in PSF)</b> Pg: NA Ct: NA CAT: NA Pf: NA Ce: NA Lu: NA Cs: NA Snow Duration: NA  Building Code: FBC 8th Ed. 2023 Res. TPI Std: 2014 Rep Fac: Yes FT/RT:20(0)/10(0) Plate Type(s): WAVE	<b>Defl/CSI Criteria</b> PP Deflection in loc L/defl L/# VERT(LL): 0.101 F 999 240 VERT(CL): 0.205 F 999 180 HORZ(LL): 0.040 H - - HORZ(TL): 0.083 H - - Creep Factor: 2.0 Max TC CSI: 0.416 Max BC CSI: 0.595 Max Web CSI: 0.893  VIEW Ver: 24.02.00D.0114.10	<b>▲ Maximum Reactions (lbs)</b> Gravity Non-Gravity Loc R+ / R- / Rh / Rw / U / RL N 1553 - / - / 794 /124 /216 H 1413 - / - / 770 /124 - Wind reactions based on MWFRS N Brg Wid = 4.9 Min Req = 1.5 (Truss) H Brg Wid = 3.5 Min Req = 1.7 (Truss) Bearings N & H are a rigid surface. Members not listed have forces less than 375# <b>Maximum Top Chord Forces Per Ply (lbs)</b> Chords Tens.Comp. Chords Tens. Comp. B - C 491 -324 E - F 607 -1711 C - D 567 -1851 F - G 692 -2256 D - E 581 -1642 G - H 653 -2379  <b>Maximum Bot Chord Forces Per Ply (lbs)</b> Chords Tens.Comp. Chords Tens. Comp. B - N 383 -368 L - K 1223 -164 N - M 1577 -355 K - J 1656 -329 M - L 1529 -306 J - H 2058 -479  <b>Maximum Web Forces Per Ply (lbs)</b> Webs Tens.Comp. Webs Tens. Comp. N - C 800 -2322 K - F 269 -527 L - E 495 -176 F - J 494 -150 E - K 667 -229
--	--	--	---	---

**Lumber**

Top chord: 2x4 SP #2;  
Bot chord: 2x4 SP #2;  
Webs: 2x4 SP #3;

**Bracing**

(a) 1x4 #3SRB SPF-S or better "T" reinforcement.  
80% length of web member. Attach with 8d Box or Gun (0.113"x2.5",min.)nails @ 6" oc.

**Wind**

Wind loads based on MWFRS with additional C&C member design.  
Left cantilever is exposed to wind  
Wind loading based on both gable and hip roof types.

**Additional Notes**

The overall height of this truss excluding overhang is 8-6-7.

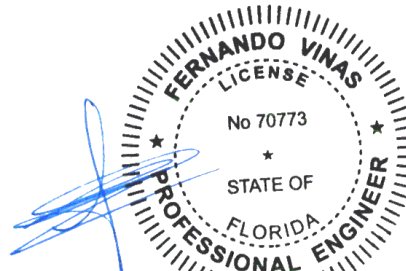

COA#0-278  
Florida Certificate of Product Approval #FL1999  
09/10/2025

**\*\*WARNING\*\* READ AND FOLLOW ALL NOTES ON THIS DRAWING!**  
**\*\*IMPORTANT\*\* FURNISH THIS DRAWING TO ALL CONTRACTORS INCLUDING THE INSTALLERS**  
Trusses require extreme care in fabricating, handling, shipping, installing and bracing. Refer to and follow the latest edition of BCSI (Building Component Safety Information, by TPI and SBCA) for safety practices prior to performing these functions. Installers shall provide temporary bracing per BCSI. Unless noted otherwise, top chord shall have properly attached structural sheathing and bottom chord shall have a properly attached rigid ceiling. Locations shown for permanent lateral restraint of webs shall have continuous lateral restraint (CLR), installed with diagonal bracing installed on the CLR per BCSI sections B3, B7, or B10, as applicable. Apply plates to each face of truss and position as shown above and on the Joint Details, unless noted otherwise. Refer to drawings 160A-Z for standard plate positions. Refer to job's General Notes page for additional information.  
Alpine, a division of ITW Building Components Group Inc. shall not be responsible for any deviation from this drawing, any failure to build the truss in conformance with ANSI/TPI 1, or for handling, shipping, installation and bracing of trusses. A seal on this drawing or cover page listing this drawing, indicates acceptance of professional engineering responsibility solely for the design shown. The suitability and use of this drawing for any structure is the responsibility of the Building Designer per ANSI/TPI 1 Sec.2.  
For more information see these web sites: Alpine: alpineitw.com; TPI: tpinst.org; SBCA: sbcacomponents.com; ICC: iccsafe.org; AWC: awc.org



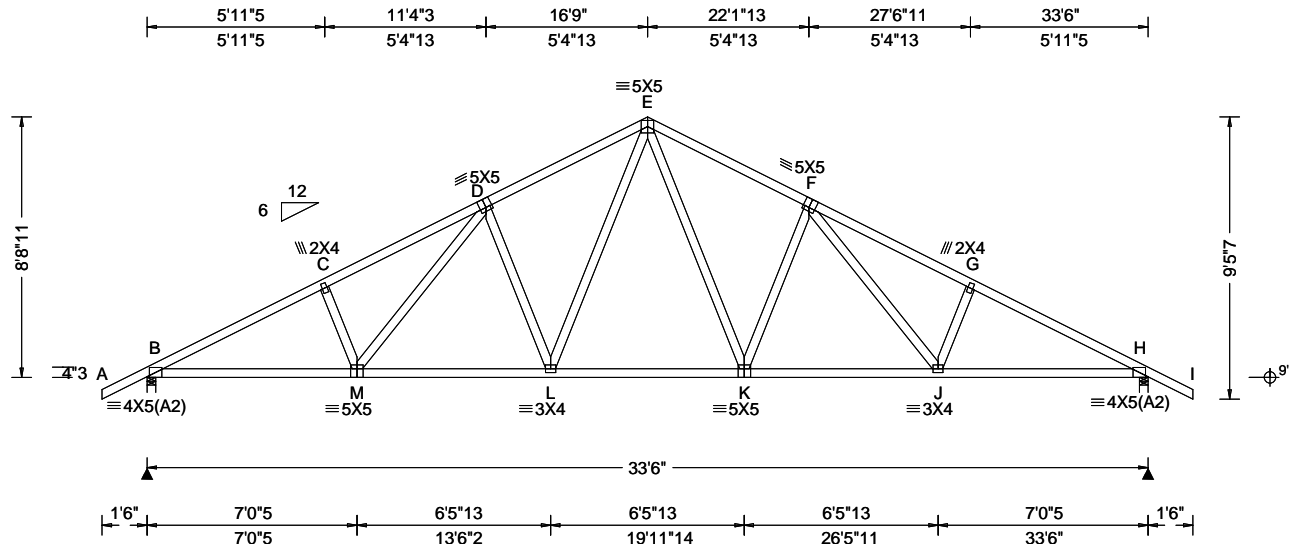

<b>Loading Criteria (psf)</b> TCLL: 20.00 TCDL: 10.00 BCLL: 0.00 BCDL: 10.00 Des Ld: 40.00 NCBCLL: 10.00 Soffit: 2.00 Load Duration: 1.25 Spacing: 24.0 "	<b>Wind Criteria</b> Wind Std: ASCE 7-22 Speed: 130 mph Enclosure: Closed Risk Category: II EXP: C Kzt: NA Mean Height: 15.00 ft TCDL: 4.2 psf BCDL: 3.0 psf MWFRS Parallel Dist: h to 2h C&C Dist a: 3.35 ft Loc. from endwall: not in 9.00 ft GCpi: 0.18 Wind Duration: 1.60	<b>Snow Criteria (Pg,Pf in PSF)</b> Pg: NA Ct: NA CAT: NA Pf: NA Ce: NA Lu: NA Cs: NA Snow Duration: NA  Building Code: FBC 8th Ed. 2023 Res. TPI Std: 2014 Rep Fac: Yes FT/RT:20(0)/10(0) Plate Type(s): WAVE	<b>Defl/CSI Criteria</b> PP Deflection in loc L/defl L/# VERT(LL): 0.142 L 999 240 VERT(CL): 0.272 L 999 180 HORZ(LL): 0.056 H - - HORZ(TL): 0.106 H - - Creep Factor: 2.0 Max TC CSI: 0.378 Max BC CSI: 0.665 Max Web CSI: 0.380  VIEW Ver: 24.02.00D.0114.10	<b>▲ Maximum Reactions (lbs)</b> Gravity Non-Gravity Loc R+ / R- / Rh / Rw / U / RL B 1547 /- /- /809 /131 /219 H 1547 /- /- /809 /131 /- Wind reactions based on MWFRS B Brg Wid = 3.5 Min Req = 1.8 (Truss) H Brg Wid = 3.5 Min Req = 1.8 (Truss) Bearings B & H are a rigid surface. Members not listed have forces less than 375# <b>Maximum Top Chord Forces Per Ply (lbs)</b> Chords Tens.Comp. Chords Tens. Comp. B - C 713 -2660 E - F 670 -2016 C - D 753 -2537 F - G 752 -2538 D - E 670 -2017 G - H 713 -2660
--	---	--	---	--

**Lumber**

Top chord: 2x4 SP #2;  
Bot chord: 2x4 SP #2;  
Webs: 2x4 SP #3;

**Loading**

Truss passed check for 20 psf additional bottom chord live load in areas with 42"-high x 24"-wide clearance.

**Wind**

Wind loads based on MWFRS with additional C&C member design.  
Wind loading based on both gable and hip roof types.

**Additional Notes**

The overall height of this truss excluding overhang is 8-8-11.

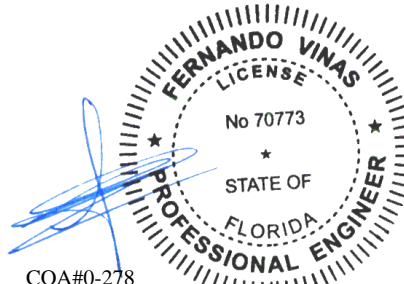

COA#0-278  
Florida Certificate of Product Approval #FL1999  
09/10/2025

**\*\*WARNING\*\* READ AND FOLLOW ALL NOTES ON THIS DRAWING!**  
**\*\*IMPORTANT\*\* FURNISH THIS DRAWING TO ALL CONTRACTORS INCLUDING THE INSTALLERS**  
Trusses require extreme care in fabricating, handling, shipping, installing and bracing. Refer to and follow the latest edition of BCSI (Building Component Safety Information, by TPI and SBCA) for safety practices prior to performing these functions. Installers shall provide temporary bracing per BCSI. Unless noted otherwise, top chord shall have properly attached structural sheathing and bottom chord shall have a properly attached rigid ceiling. Locations shown for permanent lateral restraint of webs shall have continuous lateral restraint (CLR), installed with diagonal bracing installed on the CLR per BCSI sections B3, B7, or B10, as applicable. Apply plates to each face of truss and position as shown above and on the Joint Details, unless noted otherwise. Refer to drawings 160A-Z for standard plate positions. Refer to job's General Notes page for additional information.  
Alpine, a division of ITW Building Components Group Inc. shall not be responsible for any deviation from this drawing, any failure to build the truss in conformance with ANSI/TPI 1, or for handling, shipping, installation and bracing of trusses. A seal on this drawing or cover page listing this drawing, indicates acceptance of professional engineering responsibility solely for the design shown. The suitability and use of this drawing for any structure is the responsibility of the Building Designer per ANSI/TPI 1 Sec.2.  
For more information see these web sites: Alpine: [alpineitw.com](http://alpineitw.com); TPI: [tpinst.org](http://tpinst.org); SBCA: [sbcacomponents.com](http://sbcacomponents.com); ICC: [iccsafe.org](http://iccsafe.org); AWC: [awc.org](http://awc.org)



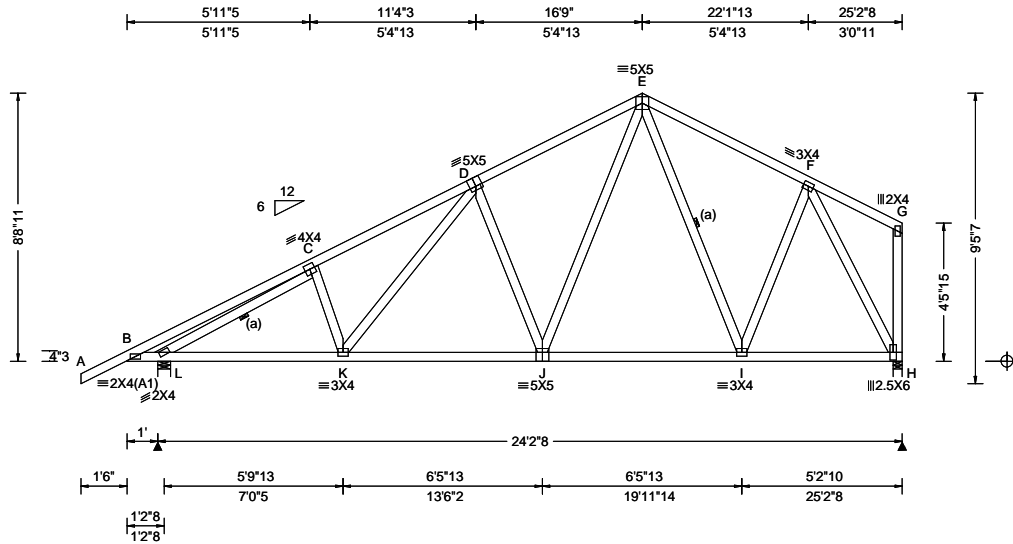

<b>Loading Criteria (psf)</b> TCLL: 20.00 TCCL: 10.00 BCLL: 0.00 BCDL: 10.00 Des Ld: 40.00 NCBCLL: 10.00 Soffit: 2.00 Load Duration: 1.25 Spacing: 24.0 "	<b>Wind Criteria</b> Wind Std: ASCE 7-22 Speed: 130 mph Enclosure: Closed Risk Category: II EXP: C Kzt: NA Mean Height: 15.00 ft TCCL: 4.2 psf BCDL: 3.0 psf MWFRS Parallel Dist: h to 2h C&C Dist a: 3.00 ft Loc. from endwall: not in 9.00 ft GCp: 0.18 Wind Duration: 1.60	<b>Snow Criteria (Pg,Pf in PSF)</b> Pg: NA Ct: NA CAT: NA Pf: NA Ce: NA Lu: NA Cs: NA Snow Duration: NA Building Code: FBC 8th Ed. 2023 Res. TPI Std: 2014 Rep Fac: Yes FT/RT:20(0)/10(0) Plate Type(s): WAVE	<b>Defl/CSI Criteria</b> PP Deflection in loc L/defl L/# VERT(LL): 0.070 D 999 240 VERT(CL): 0.086 D 999 180 HORZ(LL): 0.028 H - - HORZ(TL): 0.034 H - - Creep Factor: 2.0 Max TC CSI: 0.401 Max BC CSI: 0.494 Max Web CSI: 0.794 VIEW Ver: 24.02.00D.0114.10	<b>▲ Maximum Reactions (lbs)</b> Gravity Non-Gravity Loc R+ / R- / Rh / Rw / U / RL L 1199 - / - / 637 / 109 / 230 H 984 - / - / 521 / 94 / - Wind reactions based on MWFRS L Brg Wid = 4.9 Min Req = 1.5 (Truss) H Brg Wid = 3.5 Min Req = 1.5 (Truss) Bearings L & H are a rigid surface. Members not listed have forces less than 375# <b>Maximum Top Chord Forces Per Ply (lbs)</b> Chords Tens.Comp. Chords Tens. Comp. C - D 440 - 1438 E - F 302 - 730 D - E 402 - 1041
				<b>Lumber</b> Top chord: 2x4 SP #2; Bot chord: 2x4 SP #2; Webs: 2x4 SP #3;

<b>Additional Notes</b> The overall height of this truss excluding overhang is 8-8-11.	<b>Maximum Web Forces Per Ply (lbs)</b> Webs Tens.Comp. Webs Tens. Comp. L - C 639 - 1757 J - E 588 - 196 D - J 235 - 443 F - H 316 - 1008
---	---

COA#0-278  
 Florida Certificate of Product Approval #FL1999  
 09/10/2025

**\*\*WARNING\*\* READ AND FOLLOW ALL NOTES ON THIS DRAWING!**  
**\*\*IMPORTANT\*\* FURNISH THIS DRAWING TO ALL CONTRACTORS INCLUDING THE INSTALLERS**  
 Trusses require extreme care in fabricating, handling, shipping, installing and bracing. Refer to and follow the latest edition of BCSI (Building Component Safety Information, by TPI and SBCA) for safety practices prior to performing these functions. Installers shall provide temporary bracing per BCSI. Unless noted otherwise, top chord shall have properly attached structural sheathing and bottom chord shall have a properly attached rigid ceiling. Locations shown for permanent lateral restraint of webs shall have continuous lateral restraint (CLR), installed with diagonal bracing installed on the CLR per BCSI sections B3, B7, or B10, as applicable. Apply plates to each face of truss and position as shown above and on the Joint Details, unless noted otherwise. Refer to drawings 160A-Z for standard plate positions. Refer to job's General Notes page for additional information.  
 Alpine, a division of ITW Building Components Group Inc. shall not be responsible for any deviation from this drawing, any failure to build the truss in conformance with ANSI/TPI 1, or for handling, shipping, installation and bracing of trusses. A seal on this drawing or cover page listing this drawing, indicates acceptance of professional engineering responsibility solely for the design shown. The suitability and use of this drawing for any structure is the responsibility of the Building Designer per ANSI/TPI 1 Sec.2.  
 For more information see these web sites: Alpine: alpineitw.com; TPI: tpinst.org; SBCA: sbccomponents.com; ICC: iccsafe.org; AWC: awc.org



SEQN: 492037 FROM: CDM	SPEC Ply: 1 Qty: 1	Job Number: 25-3021 JUDY MCHUGH Truss Label: B17	Cust: R 215 JRef: 1Yd92150003 T36 DrwNo: 252.25.1344.52647 GA / FV 09/09/2025
---------------------------	--------------------------	--	---

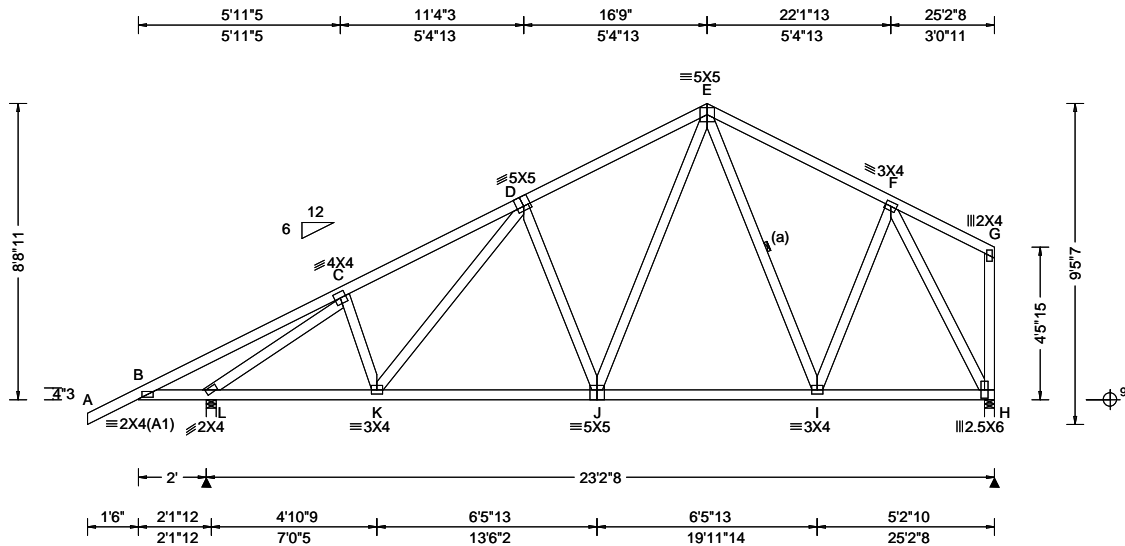

<b>Loading Criteria (psf)</b> TCCL: 20.00 TCCL: 10.00 BCLL: 0.00 BCDL: 10.00 Des Ld: 40.00 NCBCLL: 10.00 Soffit: 2.00 Load Duration: 1.25 Spacing: 24.0 "	<b>Wind Criteria</b> Wind Std: ASCE 7-22 Speed: 130 mph Enclosure: Closed Risk Category: II EXP: C Kzt: NA Mean Height: 15.00 ft TCCL: 4.2 psf BCDL: 3.0 psf MWFRS Parallel Dist: h to 2h C&C Dist a: 3.00 ft Loc. from endwall: not in 9.00 ft GCpi: 0.18 Wind Duration: 1.60	<b>Snow Criteria (Pg,Pf in PSF)</b> Pg: NA Ct: NA CAT: NA Pf: NA Ce: NA Lu: NA Cs: NA Snow Duration: NA  Building Code: FBC 8th Ed. 2023 Res. TPI Std: 2014 Rep Fac: Yes FT/RT:20(0)/10(0) Plate Type(s): WAVE	<b>Defl/CSI Criteria</b> PP Deflection in loc L/defl L/# VERT(LL): 0.032 D 999 240 VERT(CL): 0.066 D 999 180 HORZ(LL): 0.013 H - - - HORZ(TL): 0.028 H - - - Creep Factor: 2.0 Max TC CSI: 0.467 Max BC CSI: 0.421 Max Web CSI: 0.930  VIEW Ver: 24.02.00D.0114.10	<b>▲ Maximum Reactions (lbs)</b> <table border="1"> <thead> <tr> <th rowspan="2">Loc</th> <th colspan="3">Gravity</th> <th colspan="3">Non-Gravity</th> </tr> <tr> <th>R+</th> <th>/R-</th> <th>/Rh</th> <th>/Rw</th> <th>/U</th> <th>/RL</th> </tr> </thead> <tbody> <tr> <td>L</td> <td>1248</td> <td>-</td> <td>-</td> <td>/630</td> <td>/106</td> <td>/230</td> </tr> <tr> <td>H</td> <td>940</td> <td>-</td> <td>-</td> <td>/496</td> <td>/91</td> <td>-</td> </tr> </tbody> </table>						Loc	Gravity			Non-Gravity			R+	/R-	/Rh	/Rw	/U	/RL	L	1248	-	-	/630	/106	/230	H	940	-	-	/496	/91	-
				Loc	Gravity			Non-Gravity																												
R+	/R-	/Rh	/Rw		/U	/RL																														
L	1248	-	-	/630	/106	/230																														
H	940	-	-	/496	/91	-																														
<b>Maximum Top Chord Forces Per Ply (lbs)</b> <table border="1"> <thead> <tr> <th>Chords</th> <th>Tens.Comp.</th> <th>Chords</th> <th>Tens. Comp.</th> </tr> </thead> <tbody> <tr> <td>B - C</td> <td>587</td> <td>D - E</td> <td>370</td> </tr> <tr> <td>C - D</td> <td>370</td> <td>E - F</td> <td>292</td> </tr> </tbody> </table>				Chords	Tens.Comp.	Chords	Tens. Comp.	B - C	587	D - E	370	C - D	370	E - F	292	<b>Maximum Bot Chord Forces Per Ply (lbs)</b> <table border="1"> <thead> <tr> <th>Chords</th> <th>Tens.Comp.</th> <th>Chords</th> <th>Tens. Comp.</th> </tr> </thead> <tbody> <tr> <td>B - L</td> <td>417</td> <td>J - I</td> <td>608</td> </tr> <tr> <td>L - K</td> <td>994</td> <td>I - H</td> <td>447</td> </tr> <tr> <td>K - J</td> <td>919</td> <td></td> <td>-141</td> </tr> </tbody> </table>		Chords	Tens.Comp.	Chords	Tens. Comp.	B - L	417	J - I	608	L - K	994	I - H	447	K - J	919		-141			
Chords	Tens.Comp.	Chords	Tens. Comp.																																	
B - C	587	D - E	370																																	
C - D	370	E - F	292																																	
Chords	Tens.Comp.	Chords	Tens. Comp.																																	
B - L	417	J - I	608																																	
L - K	994	I - H	447																																	
K - J	919		-141																																	

**Lumber**

Top chord: 2x4 SP #2;  
 Bot chord: 2x4 SP #2;  
 Webs: 2x4 SP #3;

**Bracing**

(a) Continuous lateral restraint equally spaced on member.

**Wind**

Wind loads based on MWFRS with additional C&C member design.  
 Right end vertical not exposed to wind pressure.  
 Left cantilever is exposed to wind  
 Wind loading based on both gable and hip roof types.

**Additional Notes**

The overall height of this truss excluding overhang is 8-8-11.

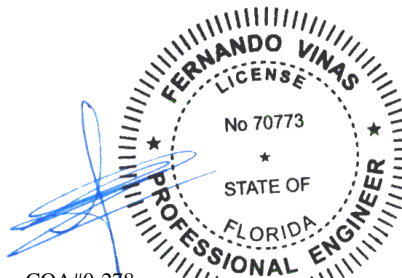

COA#0-278  
 Florida Certificate of Product Approval #FL1999  
 09/10/2025

**\*\*WARNING\*\* READ AND FOLLOW ALL NOTES ON THIS DRAWING!**  
**\*\*IMPORTANT\*\* FURNISH THIS DRAWING TO ALL CONTRACTORS INCLUDING THE INSTALLERS**  
 Trusses require extreme care in fabricating, handling, shipping, installing and bracing. Refer to and follow the latest edition of BCSI (Building Component Safety Information, by TPI and SBCA) for safety practices prior to performing these functions. Installers shall provide temporary bracing per BCSI. Unless noted otherwise, top chord shall have properly attached structural sheathing and bottom chord shall have a properly attached rigid ceiling. Locations shown for permanent lateral restraint of webs shall have continuous lateral restraint (CLR), installed with diagonal bracing installed on the CLR per BCSI sections B3, B7, or B10, as applicable. Apply plates to each face of truss and position as shown above and on the Joint Details, unless noted otherwise. Refer to drawings 160A-Z for standard plate positions. Refer to job's General Notes page for additional information.  
 Alpine, a division of ITW Building Components Group Inc. shall not be responsible for any deviation from this drawing, any failure to build the truss in conformance with ANSI/TPI 1, or for handling, shipping, installation and bracing of trusses. A seal on this drawing or cover page listing this drawing, indicates acceptance of professional engineering responsibility solely for the design shown. The suitability and use of this drawing for any structure is the responsibility of the Building Designer per ANSI/TPI 1 Sec.2.  
 For more information see these web sites: Alpine: alpineitw.com; TPI: tpinst.org; SBCA: sbcacomponents.com; ICC: iccsafe.org; AWC: awc.org



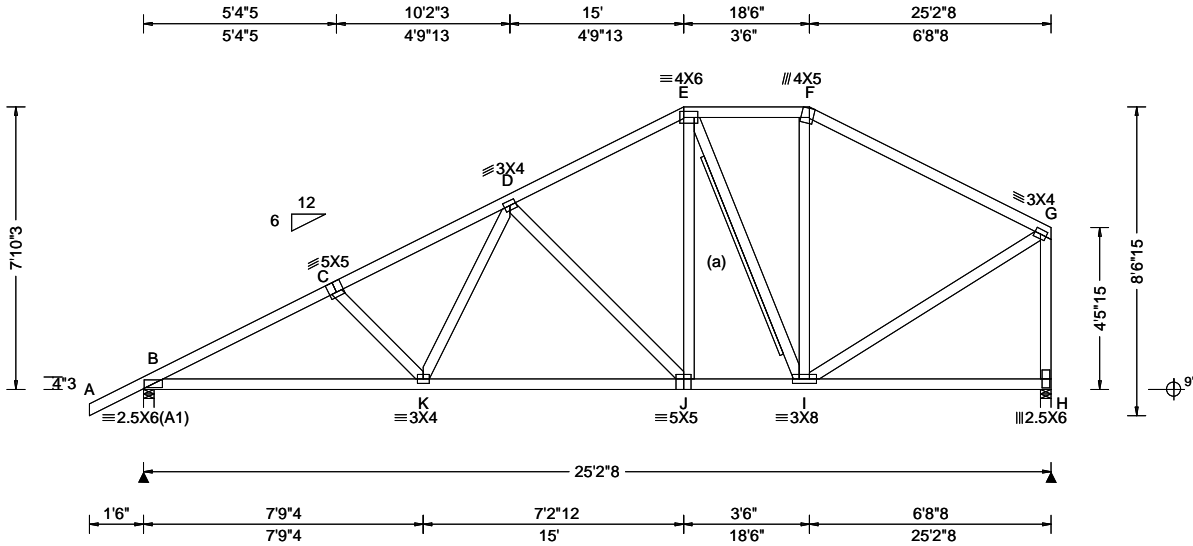

<b>Loading Criteria (psf)</b> TCLL: 20.00 TCDL: 10.00 BCLL: 0.00 BCDL: 10.00 Des Ld: 40.00 NCBCLL: 10.00 Soffit: 2.00 Load Duration: 1.25 Spacing: 24.0 "	<b>Wind Criteria</b> Wind Std: ASCE 7-22 Speed: 130 mph Enclosure: Closed Risk Category: II EXP: C Kzt: NA Mean Height: 15.00 ft TCDL: 4.2 psf BCDL: 3.0 psf MWFRS Parallel Dist: h to 2h C&C Dist a: 3.00 ft Loc. from endwall: not in 9.00 ft GCp: 0.18 Wind Duration: 1.60	<b>Snow Criteria (Pg,Pf in PSF)</b> Pg: NA Ct: NA CAT: NA Pf: NA Ce: NA Lu: NA Cs: NA Snow Duration: NA  Building Code: FBC 8th Ed. 2023 Res. TPI Std: 2014 Rep Fac: Yes FT/RT:20(0)/10(0) Plate Type(s): WAVE	<b>Defl/CSI Criteria</b> PP Deflection in loc L/defl L/# VERT(LL): 0.056 K 999 240 VERT(CL): 0.115 K 999 180 HORZ(LL): 0.019 I - - HORZ(TL): 0.038 I - - Creep Factor: 2.0 Max TC CSI: 0.744 Max BC CSI: 0.643 Max Web CSI: 0.549  VIEW Ver: 24.02.00D.0114.10	<b>▲ Maximum Reactions (lbs)</b> Gravity Non-Gravity Loc R+ / R- / Rh / Rw / U / RL B 1148 /- /- /643 /133 /208 H 1028 /- /- /539 /111 /- Wind reactions based on MWFRS B Brg Wid = 3.5 Min Req = 1.5 (Truss) H Brg Wid = 3.5 Min Req = 1.5 (Truss) Bearings B & H are a rigid surface. Members not listed have forces less than 375# <b>Maximum Top Chord Forces Per Ply (lbs)</b> Chords Tens.Comp. Chords Tens. Comp. B - C 585 - 1820 E - F 415 - 714 C - D 563 - 1612 F - G 388 - 878 D - E 464 - 1012  <b>Maximum Bot Chord Forces Per Ply (lbs)</b> Chords Tens.Comp. Chords Tens. Comp. B - K 1566 - 635 J - I 836 - 339 K - J 1224 - 504  <b>Maximum Web Forces Per Ply (lbs)</b> Webs Tens.Comp. Webs Tens. Comp. K - D 437 - 68 I - G 837 - 330 D - J 239 - 560 G - H 417 - 971 E - J 496 - 147
--	--	--	---	---

**Lumber**

Top chord: 2x4 SP #2;  
Bot chord: 2x4 SP #2;  
Webs: 2x4 SP #3;

**Bracing**

(a) 1x4 #3SRB SPF-S or better "T" reinforcement.  
80% length of web member. Attach with 8d Box or Gun (0.113"x2.5",min.)nails @ 6" oc.

**Purlins**

In lieu of structural panels use purlins to brace all flat TC @ 24" oc.

**Wind**

Wind loads based on MWFRS with additional C&C member design.  
Right end vertical not exposed to wind pressure.  
Wind loading based on both gable and hip roof types.

**Additional Notes**

The overall height of this truss excluding overhang is 7-10-3.

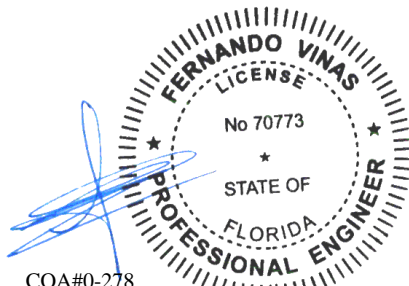

COA#0-278  
Florida Certificate of Product Approval #FL1999  
09/10/2025

**\*\*WARNING\*\* READ AND FOLLOW ALL NOTES ON THIS DRAWING!**  
**\*\*IMPORTANT\*\* FURNISH THIS DRAWING TO ALL CONTRACTORS INCLUDING THE INSTALLERS**  
Trusses require extreme care in fabricating, handling, shipping, installing and bracing. Refer to and follow the latest edition of BCSI (Building Component Safety Information, by TPI and SBCA) for safety practices prior to performing these functions. Installers shall provide temporary bracing per BCSI. Unless noted otherwise, top chord shall have properly attached structural sheathing and bottom chord shall have a properly attached rigid ceiling. Locations shown for permanent lateral restraint of webs shall have continuous lateral restraint (CLR), installed with diagonal bracing installed on the CLR per BCSI sections B3, B7, or B10, as applicable. Apply plates to each face of truss and position as shown above and on the Joint Details, unless noted otherwise. Refer to drawings 160A-Z for standard plate positions. Refer to job's General Notes page for additional information.  
Alpine, a division of ITW Building Components Group Inc. shall not be responsible for any deviation from this drawing, any failure to build the truss in conformance with ANSI/TPI 1, or for handling, shipping, installation and bracing of trusses. A seal on this drawing or cover page listing this drawing, indicates acceptance of professional engineering responsibility solely for the design shown. The suitability and use of this drawing for any structure is the responsibility of the Building Designer per ANSI/TPI 1 Sec.2.  
For more information see these web sites: Alpine: alpineitw.com; TPI: tpinst.org; SBCA: sbccomponents.com; ICC: iccsafe.org; AWC: awc.org



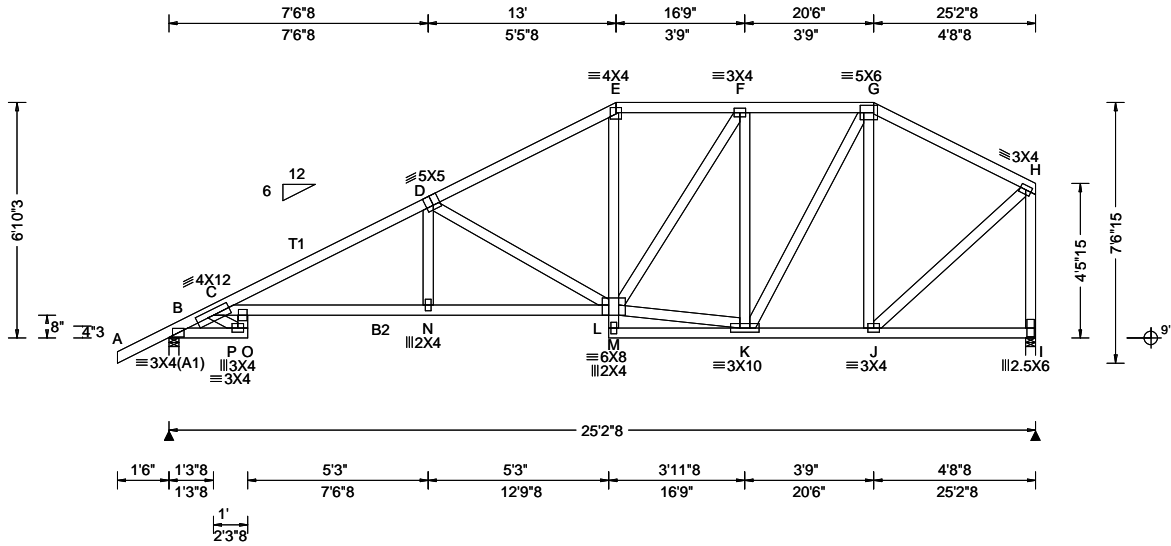

<b>Loading Criteria (psf)</b> TCLL: 20.00 TCDL: 10.00 BCLL: 0.00 BCDL: 10.00 Des Ld: 40.00 NCBCLL: 10.00 Soffit: 2.00 Load Duration: 1.25 Spacing: 24.0 "	<b>Wind Criteria</b> Wind Std: ASCE 7-22 Speed: 130 mph Enclosure: Closed Risk Category: II EXP: C Kzt: NA Mean Height: 15.00 ft TCDL: 4.2 psf BCDL: 3.0 psf MWFRS Parallel Dist: h/2 to h C&C Dist a: 3.00 ft Loc. from endwall: not in 9.00 ft GCpi: 0.18 Wind Duration: 1.60	<b>Snow Criteria (Pg,Pf in PSF)</b> Pg: NA Ct: NA CAT: NA Pf: NA Ce: NA Lu: NA Cs: NA Snow Duration: NA  <b>Building Code:</b> FBC 8th Ed. 2023 Res. TPI Std: 2014 Rep Fac: Yes FT/RT:20(0)/10(0) Plate Type(s): WAVE	<b>Defl/CSI Criteria</b> PP Deflection in loc L/defl L/# VERT(LL): 0.223 O 999 240 VERT(CL): 0.454 O 662 180 HORZ(LL): 0.090 J - - HORZ(TL): 0.184 J - - Creep Factor: 2.0 Max TC CSI: 0.560 Max BC CSI: 0.639 Max Web CSI: 0.610  VIEW Ver: 24.02.00D.0114.10	<b>▲ Maximum Reactions (lbs)</b> Gravity Non-Gravity Loc R+ /R- /Rh /Rw /U /RL B 1148 -/ - /642 /273 /182 I 1028 -/ - /533 /266 -/ Wind reactions based on MWFRS B Brg Wid = 3.5 Min Req = 1.5 (Truss) I Brg Wid = 3.5 Min Req = 1.5 (Truss) Bearings B & I are a rigid surface. Members not listed have forces less than 375# <b>Maximum Top Chord Forces Per Ply (lbs)</b> Chords Tens.Comp. Chords Tens. Comp. B - C 507 -1377 E - F 666 -1127 C - D 867 -2122 F - G 559 -888 D - E 693 -1361 G - H 403 -753
--	--	---	---	---

**Lumber**

Top chord: 2x4 SP #2; T1 2x4 SP M-31;  
Bot chord: 2x4 SP #2; B2 2x4 SP M-31;  
Webs: 2x4 SP #3;

**Purlins**

In lieu of structural panels use purlins to brace all flat TC @ 24" oc.

**Wind**

Wind loads based on MWFRS with additional C&C member design.  
Right end vertical not exposed to wind pressure.  
Wind loading based on both gable and hip roof types.

**Additional Notes**

The overall height of this truss excluding overhang is 6-10-3.

**Maximum Bot Chord Forces Per Ply (lbs)**

Chords	Tens.Comp.	Chords	Tens. Comp.
B - O	1042 -540	N - L	1848 -874
C - P	1963 -931	K - J	623 -315
P - N	1854 -874		

**Maximum Web Forces Per Ply (lbs)**

Webs	Tens.Comp.	Webs	Tens. Comp.
C - O	705 -1361	F - K	399 -570
P - O	741 -369	K - G	531 -318
D - L	336 -823	G - J	308 -456
L - F	422 -183	J - H	834 -421
L - K	874 -466	H - I	512 -990

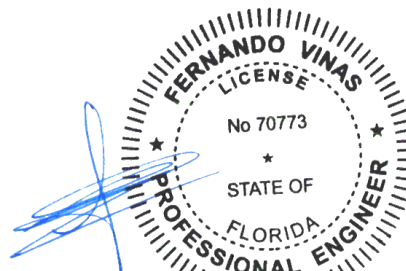

COA#0-278  
Florida Certificate of Product Approval #FL1999  
09/10/2025

**\*\*WARNING\*\* READ AND FOLLOW ALL NOTES ON THIS DRAWING!**  
**\*\*IMPORTANT\*\* FURNISH THIS DRAWING TO ALL CONTRACTORS INCLUDING THE INSTALLERS**  
Trusses require extreme care in fabricating, handling, shipping, installing and bracing. Refer to and follow the latest edition of BCSI (Building Component Safety Information, by TPI and SBCA) for safety practices prior to performing these functions. Installers shall provide temporary bracing per BCSI. Unless noted otherwise, top chord shall have properly attached structural sheathing and bottom chord shall have a properly attached rigid ceiling. Locations shown for permanent lateral restraint of webs shall have continuous lateral restraint (CLR), installed with diagonal bracing installed on the CLR per BCSI sections B3, B7, or B10, as applicable. Apply plates to each face of truss and position as shown above and on the Joint Details, unless noted otherwise. Refer to drawings 160A-Z for standard plate positions. Refer to job's General Notes page for additional information.  
Alpine, a division of ITW Building Components Group Inc. shall not be responsible for any deviation from this drawing, any failure to build the truss in conformance with ANSI/TPI 1, or for handling, shipping, installation and bracing of trusses. A seal on this drawing or cover page listing this drawing, indicates acceptance of professional engineering responsibility solely for the design shown. The suitability and use of this drawing for any structure is the responsibility of the Building Designer per ANSI/TPI 1 Sec.2.  
For more information see these web sites: Alpine: alpineitw.com; TPI: tpinst.org; SBCA: sbcacomponents.com; ICC: iccsafe.org; AWC: awc.org





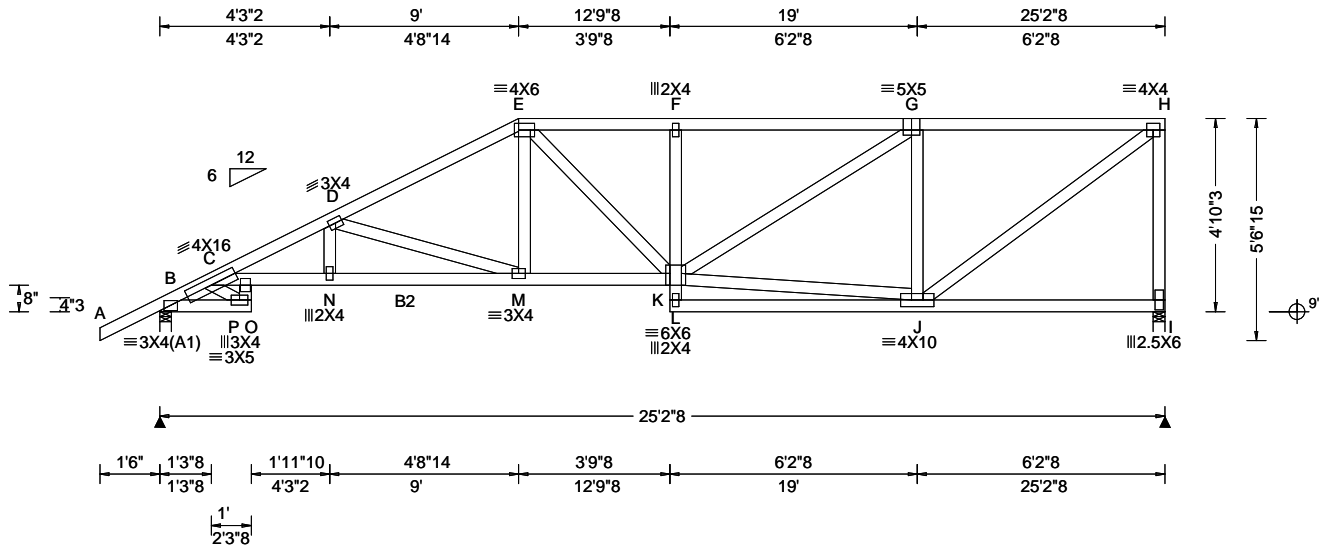

<b>Loading Criteria (psf)</b> TCCL: 20.00 TCDL: 10.00 BCLL: 0.00 BCDL: 10.00 Des Ld: 40.00 NCBCLL: 10.00 Soffit: 2.00 Load Duration: 1.25 Spacing: 24.0 "	<b>Wind Criteria</b> Wind Std: ASCE 7-22 Speed: 130 mph Enclosure: Closed Risk Category: II EXP: C Kzt: NA Mean Height: 15.00 ft TCDL: 4.2 psf BCDL: 3.0 psf MWFRS Parallel Dist: h/2 to h C&C Dist a: 3.00 ft Loc. from endwall: not in 9.00 ft GCp: 0.18 Wind Duration: 1.60	<b>Snow Criteria (Pg,Pf in PSF)</b> Pg: NA Ct: NA CAT: NA Pf: NA Ce: NA Lu: NA Cs: NA Snow Duration: NA Building Code: FBC 8th Ed. 2023 Res. TPI Std: 2014 Rep Fac: Yes FT/RT:20(0)/10(0) Plate Type(s): WAVE	<b>Defl/CSI Criteria</b> PP Deflection in loc L/defl L/# VERT(LL): 0.126 O 999 240 VERT(CL): 0.256 O 999 180 HORZ(LL): 0.064 J - - HORZ(TL): 0.130 J - - Creep Factor: 2.0 Max TC CSI: 0.657 Max BC CSI: 0.621 Max Web CSI: 0.973 VIEW Ver: 24.02.00D.0114.10	<b>▲ Maximum Reactions (lbs)</b> Gravity Non-Gravity Loc R+ / R- / Rh / Rw / U / RL B 1148 - / - / - /626 /274 /180 I 1028 - / - / - /542 /276 - / - Wind reactions based on MWFRS B Brg Wid = 3.5 Min Req = 1.5 (Truss) I Brg Wid = 3.5 Min Req = 1.5 (Truss) Bearings B & I are a rigid surface. Members not listed have forces less than 375# <b>Maximum Top Chord Forces Per Ply (lbs)</b> Chords Tens.Comp. Chords Tens. Comp.
				B - C 619 -1451 E - F 1104 -1742 C - D 1366 -2718 F - G 1095 -1729 D - E 984 -1782 G - H 732 -1118

**Lumber**  
 Top chord: 2x4 SP #2;  
 Bot chord: 2x4 SP #2; B2 2x4 SP M-31;  
 Webs: 2x4 SP #3;

**Purlins**  
 In lieu of structural panels use purlins to brace all flat TC @ 24" oc.

**Wind**  
 Wind loads based on MWFRS with additional C&C member design.  
 Right end vertical not exposed to wind pressure.  
 Wind loading based on both gable and hip roof types.

**Additional Notes**  
 The overall height of this truss excluding overhang is 4-10-3.

<b>Maximum Bot Chord Forces Per Ply (lbs)</b>			
Chords	Tens.Comp.	Chords	Tens. Comp.
B - O	1127 -639	N - M	2416 -1372
C - P	2563 -1449	M - K	1534 -930
P - N	2437 -1379		
<b>Maximum Web Forces Per Ply (lbs)</b>			
Webs	Tens.Comp.	Webs	Tens. Comp.
C - O	836 -1480	K - J	1068 -711
P - O	800 -439	G - J	680 -816
N - D	405 -142	J - H	1387 -908
D - M	467 -931	H - I	705 -979
K - G	692 -428		

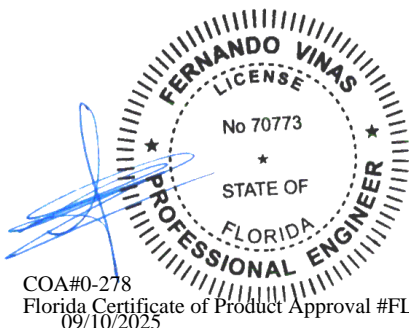

**\*\*WARNING\*\* READ AND FOLLOW ALL NOTES ON THIS DRAWING!**  
**\*\*IMPORTANT\*\* FURNISH THIS DRAWING TO ALL CONTRACTORS INCLUDING THE INSTALLERS**  
 Trusses require extreme care in fabricating, handling, shipping, installing and bracing. Refer to and follow the latest edition of BCSI (Building Component Safety Information, by TPI and SBCA) for safety practices prior to performing these functions. Installers shall provide temporary bracing per BCSI. Unless noted otherwise, top chord shall have properly attached structural sheathing and bottom chord shall have a properly attached rigid ceiling. Locations shown for permanent lateral restraint of webs shall have continuous lateral restraint (CLR), installed with diagonal bracing installed on the CLR per BCSI sections B3, B7, or B10, as applicable. Apply plates to each face of truss and position as shown above and on the Joint Details, unless noted otherwise. Refer to drawings 160A-Z for standard plate positions. Refer to job's General Notes page for additional information.  
 Alpine, a division of ITW Building Components Group Inc. shall not be responsible for any deviation from this drawing, any failure to build the truss in conformance with ANSI/TPI 1, or for handling, shipping, installation and bracing of trusses. A seal on this drawing or cover page listing this drawing, indicates acceptance of professional engineering responsibility solely for the design shown. The suitability and use of this drawing for any structure is the responsibility of the Building Designer per ANSI/TPI 1 Sec.2.  
 For more information see these web sites: Alpine: alpineitw.com; TPI: tpinst.org; SBCA: sbcacomponents.com; ICC: iccsafe.org; AWC: awc.org



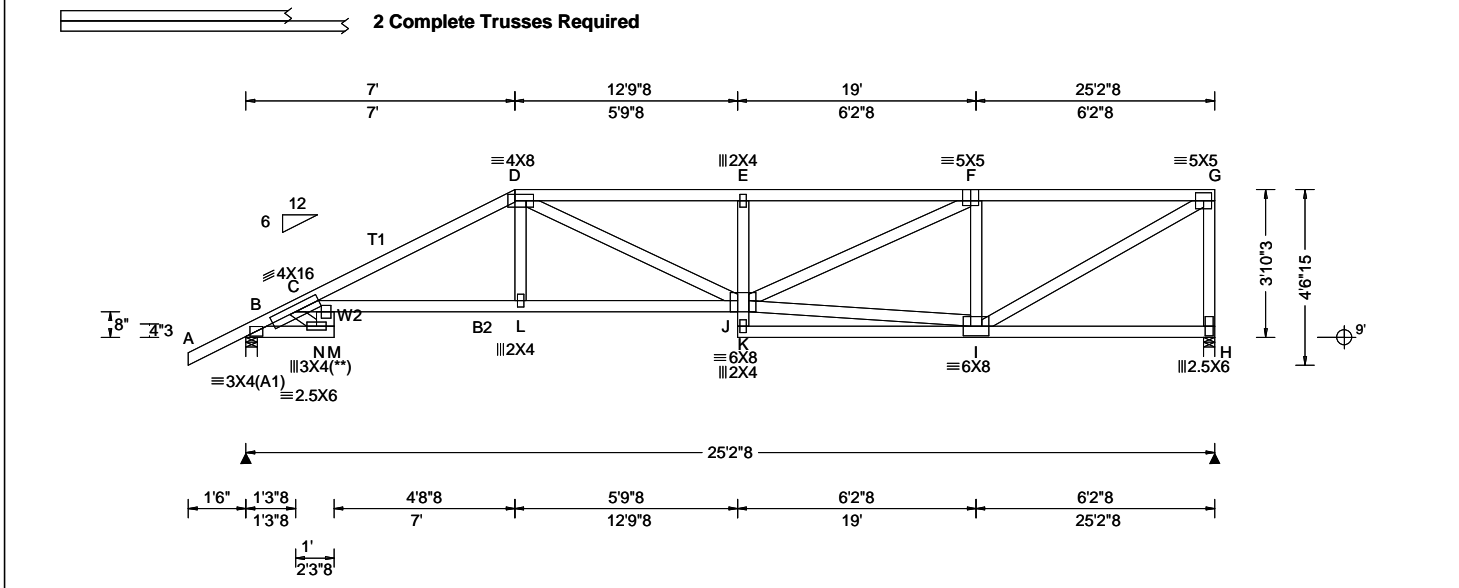

<b>Loading Criteria (psf)</b> TCLL: 20.00 TCDL: 10.00 BCLL: 0.00 BCDL: 10.00 Des Ld: 40.00 NCBCLL: 0.00 Soffit: 2.00 Load Duration: 1.25 Spacing: 24.0 "	<b>Wind Criteria</b> Wind Std: ASCE 7-22 Speed: 130 mph Enclosure: Closed Risk Category: II EXP: C Kzt: NA Mean Height: 15.00 ft TCDL: 4.2 psf BCDL: 3.0 psf MWFRS Parallel Dist: 0 to h/2 C&C Dist a: 3.00 ft Loc. from endwall: not in 4.50 ft GCp: 0.18 Wind Duration: 1.60	<b>Snow Criteria (Pg,Pf in PSF)</b> Pg: NA Ct: NA CAT: NA Pf: NA Ce: NA Lu: NA Cs: NA Snow Duration: NA Building Code: FBC 8th Ed. 2023 Res. TPI Std: 2014 Rep Fac: Varies by Ld Case FT/RT:20(0)/10(0) Plate Type(s): WAVE	<b>Defl/CSI Criteria</b> PP Deflection in loc L/defl L/# VERT(LL): 0.426 M 705 240 VERT(CL): 0.471 M 638 180 HORZ(LL): 0.201 H - - HORZ(TL): 0.227 H - - Creep Factor: 2.0 Max TC CSI: 0.700 Max BC CSI: 0.813 Max Web CSI: 0.783 VIEW Ver: 24.02.00D.0114.10	<b>▲ Maximum Reactions (lbs)</b> Gravity Non-Gravity Loc R+ / R- / Rh / Rw / U / RL B 2437 /- /- /- /693 /- H 2699 /- /- /- /787 /- Wind reactions based on MWFRS B Brg Wid = 3.5 Min Req = 1.5 (Truss) H Brg Wid = 3.5 Min Req = 1.6 (Truss) Bearings B & H are a rigid surface. Members not listed have forces less than 375# <b>Maximum Top Chord Forces Per Ply (lbs)</b> Chords Tens.Comp. Chords Tens. Comp. B - C 448 -1538 E - F 881 -3011 C - D 811 -2853 F - G 519 -1802 D - E 892 -3049					
				<b>Maximum Bot Chord Forces Per Ply (lbs)</b> Chords Tens.Comp. Chords Tens. Comp. B - M 1143 -337 N - L 2557 -722 C - N 2656 -753 L - J 2586 -728 <b>Maximum Web Forces Per Ply (lbs)</b> Webs Tens.Comp. Webs Tens. Comp. C - M 435 -1470 J - I 1681 -490 N - M 783 -225 F - I 383 -978 D - L 546 -113 I - G 2056 -591 D - J 519 -181 G - H 400 -1228 J - F 1287 -382					

**Lumber**  
 Top chord: 2x4 SP #2; T1 2x4 SP M-31;  
 Bot chord: 2x4 SP #2; B2 2x4 SP M-31;  
 Webs: 2x4 SP #3; W2 2x6 SP #2;

**Nailnote**  
 Nail Schedule: 0.131"x3", min. nails  
 Top Chord: 1 Row @12.00" o.c.  
 Bot Chord: 1 Row @12.00" o.c.  
 Webs : 1 Row @ 4" o.c.  
 Use equal spacing between rows and stagger nails in each row to avoid splitting.

**Special Loads**  
 -----(Lumber Dur.Fac.=1.25 / Plate Dur.Fac.=1.25)  
 TC: From 62 plf at -1.50 to 62 plf at 7.00  
 TC: From 31 plf at 7.00 to 31 plf at 25.21  
 BC: From 4 plf at -1.50 to 4 plf at 0.00  
 BC: From 20 plf at 0.00 to 20 plf at 7.03  
 BC: From 10 plf at 7.03 to 10 plf at 25.21  
 TC: 387 lb Conc. Load at 7.03  
 TC: 143 lb Conc. Load at 9.06,11.06  
 TC: 187 lb Conc. Load at 13.06,15.06,17.06,19.06  
 21.06,23.06,24.85  
 BC: 526 lb Conc. Load at 7.03  
 BC: 150 lb Conc. Load at 9.06,11.06  
 BC: 129 lb Conc. Load at 13.06,15.06,17.06,19.06  
 21.06,23.06,24.85

**Plating Notes**  
 (\*\*) 1 plate(s) require special positioning. Refer to scaled plate plot details for special positioning requirements.

**Purlins**  
 In lieu of structural panels use purlins to brace all flat TC @ 24" o.c.

**Wind**  
 Wind loads and reactions based on MWFRS.  
 Right end vertical not exposed to wind pressure.  
 Wind loading based on both gable and hip roof types.

**Additional Notes**  
 The overall height of this truss excluding overhang is 3-10.3.

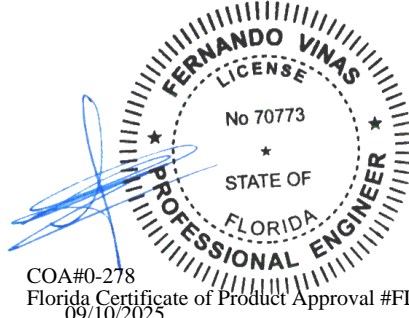

**\*\*WARNING\*\* READ AND FOLLOW ALL NOTES ON THIS DRAWING!**  
**\*\*IMPORTANT\*\* FURNISH THIS DRAWING TO ALL CONTRACTORS INCLUDING THE INSTALLERS**  
 Trusses require extreme care in fabricating, handling, shipping, installing and bracing. Refer to and follow the latest edition of BCSI (Building Component Safety Information, by TPI and SBCA) for safety practices prior to performing these functions. Installers shall provide temporary bracing per BCSI. Unless noted otherwise, top chord shall have properly attached structural sheathing and bottom chord shall have a properly attached rigid ceiling. Locations shown for permanent lateral restraint of webs shall have continuous lateral restraint (CLR), installed with diagonal bracing installed on the CLR per BCSI sections B3, B7, or B10, as applicable. Apply plates to each face of truss and position as shown above and on the Joint Details, unless noted otherwise. Refer to drawings 160A-Z for standard plate positions. Refer to job's General Notes page for additional information.  
 Alpine, a division of ITW Building Components Group Inc. shall not be responsible for any deviation from this drawing, any failure to build the truss in conformance with ANSI/TPI 1, or for handling, shipping, installation and bracing of trusses. A seal on this drawing or cover page listing this drawing, indicates acceptance of professional engineering responsibility solely for the design shown. The suitability and use of this drawing for any structure is the responsibility of the Building Designer per ANSI/TPI 1 Sec.2.  
 For more information see these web sites: Alpine: alpineitw.com; TPI: tpinst.org; SBCA: sbcacomponents.com; ICC: iccsafe.org; AWC: awc.org

155 Harlem Ave  
 North Building, 4th Floor  
 Glenview, IL 60025

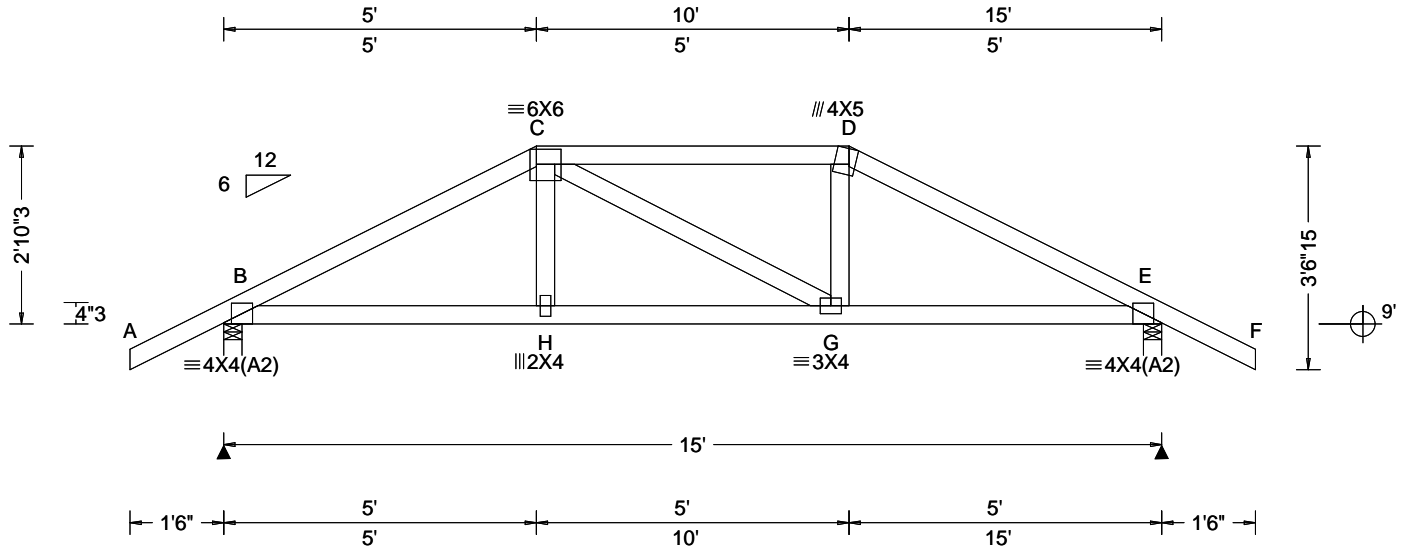

<b>Loading Criteria (psf)</b> TCLL: 20.00 TCDL: 10.00 BCLL: 0.00 BCDL: 10.00 Des Ld: 40.00 NCBCLL: 10.00 Soffit: 2.00 Load Duration: 1.25 Spacing: 24.0 "	<b>Wind Criteria</b> Wind Std: ASCE 7-22 Speed: 130 mph Enclosure: Closed Risk Category: II EXP: C Kzt: NA Mean Height: 15.00 ft TCDL: 4.2 psf BCDL: 3.0 psf MWFRS Parallel Dist: 0 to h/2 C&C Dist a: 3.00 ft Loc. from endwall: not in 4.50 ft GCp: 0.18 Wind Duration: 1.60	<b>Snow Criteria (Pg,Pf in PSF)</b> Pg: NA Ct: NA CAT: NA Pf: NA Ce: NA Lu: NA Cs: NA Snow Duration: NA  <b>Building Code:</b> FBC 8th Ed. 2023 Res. TPI Std: 2014 Rep Fac: Varies by Ld Case FT/RT:20(0)/10(0) Plate Type(s): WAVE	<b>Defl/CSI Criteria</b> PP Deflection in loc L/defl L/# VERT(LL): 0.099 G 999 240 VERT(CL): 0.113 G 999 180 HORZ(LL): 0.046 E - - HORZ(TL): 0.050 E - - Creep Factor: 2.0 Max TC CSI: 0.899 Max BC CSI: 0.818 Max Web CSI: 0.120  VIEW Ver: 24.02.00D.0114.10	<b>▲ Maximum Reactions (lbs)</b> <table style="width:100%; border-collapse: collapse;"> <thead> <tr> <th rowspan="2">Loc</th> <th colspan="3">Gravity</th> <th colspan="3">Non-Gravity</th> </tr> <tr> <th>R+</th> <th>/R-</th> <th>/Rh</th> <th>/Rw</th> <th>/U</th> <th>/RL</th> </tr> </thead> <tbody> <tr> <td>B</td> <td>1342</td> <td>-</td> <td>-</td> <td>-</td> <td>/368</td> <td>-</td> </tr> <tr> <td>E</td> <td>1342</td> <td>-</td> <td>-</td> <td>-</td> <td>/368</td> <td>-</td> </tr> </tbody> </table> <p>Wind reactions based on MWFRS          B Brg Wid = 3.5 Min Req = 1.6 (Truss)          E Brg Wid = 3.5 Min Req = 1.6 (Truss)          Bearings B &amp; E are a rigid surface.          Members not listed have forces less than 375#  <b>Maximum Top Chord Forces Per Ply (lbs)</b>  <table style="width:100%; border-collapse: collapse;"> <thead> <tr> <th>Chords</th> <th>Tens.Comp.</th> <th>Chords</th> <th>Tens.Comp.</th> </tr> </thead> <tbody> <tr> <td>B - C</td> <td>618 - 2288</td> <td>D - E</td> <td>620 - 2284</td> </tr> <tr> <td>C - D</td> <td>523 - 2020</td> <td></td> <td></td> </tr> </tbody> </table>   <b>Maximum Bot Chord Forces Per Ply (lbs)</b>  <table style="width:100%; border-collapse: collapse;"> <thead> <tr> <th>Chords</th> <th>Tens.Comp.</th> <th>Chords</th> <th>Tens.Comp.</th> </tr> </thead> <tbody> <tr> <td>B - H</td> <td>1987 - 529</td> <td>G - E</td> <td>1984 - 530</td> </tr> <tr> <td>H - G</td> <td>2005 - 525</td> <td></td> <td></td> </tr> </tbody> </table> </p>	Loc	Gravity			Non-Gravity			R+	/R-	/Rh	/Rw	/U	/RL	B	1342	-	-	-	/368	-	E	1342	-	-	-	/368	-	Chords	Tens.Comp.	Chords	Tens.Comp.	B - C	618 - 2288	D - E	620 - 2284	C - D	523 - 2020			Chords	Tens.Comp.	Chords	Tens.Comp.	B - H	1987 - 529	G - E	1984 - 530	H - G	2005 - 525		
Loc	Gravity			Non-Gravity																																																			
	R+	/R-	/Rh	/Rw	/U	/RL																																																	
B	1342	-	-	-	/368	-																																																	
E	1342	-	-	-	/368	-																																																	
Chords	Tens.Comp.	Chords	Tens.Comp.																																																				
B - C	618 - 2288	D - E	620 - 2284																																																				
C - D	523 - 2020																																																						
Chords	Tens.Comp.	Chords	Tens.Comp.																																																				
B - H	1987 - 529	G - E	1984 - 530																																																				
H - G	2005 - 525																																																						

**Lumber**

Top chord: 2x4 SP #2;  
 Bot chord: 2x4 SP #2;  
 Webs: 2x4 SP #3;

**Special Loads**

----(Lumber Dur.Fac.=1.25 / Plate Dur.Fac.=1.25)  
 TC: From 62 plf at -1.50 to 62 plf at 5.00  
 TC: From 31 plf at 5.00 to 31 plf at 10.00  
 TC: From 62 plf at 10.00 to 62 plf at 16.50  
 BC: From 4 plf at -1.50 to 4 plf at 0.00  
 BC: From 20 plf at 0.00 to 20 plf at 5.03  
 BC: From 10 plf at 5.03 to 10 plf at 9.97  
 BC: From 20 plf at 9.97 to 20 plf at 15.00  
 BC: From 4 plf at 15.00 to 4 plf at 16.50  
 TC: 339 lb Conc. Load at 5.03, 9.97  
 TC: 127 lb Conc. Load at 7.06, 7.94  
 BC: 171 lb Conc. Load at 5.03, 9.97  
 BC: 89 lb Conc. Load at 7.06, 7.94

**Purlins**

In lieu of structural panels use purlins to brace all flat TC @ 24" oc.

**Wind**

Wind loads and reactions based on MWFRS.  
 Wind loading based on both gable and hip roof types.

**Additional Notes**

The overall height of this truss excluding overhang is 2-10-3.

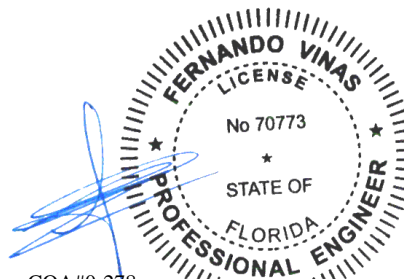

COA#0-278  
 Florida Certificate of Product Approval #FL1999  
 09/10/2025

**\*\*WARNING\*\* READ AND FOLLOW ALL NOTES ON THIS DRAWING!**  
**\*\*IMPORTANT\*\* FURNISH THIS DRAWING TO ALL CONTRACTORS INCLUDING THE INSTALLERS**  
 Trusses require extreme care in fabricating, handling, shipping, installing and bracing. Refer to and follow the latest edition of BCSI (Building Component Safety Information, by TPI and SBCA) for safety practices prior to performing these functions. Installers shall provide temporary bracing per BCSI. Unless noted otherwise, top chord shall have properly attached structural sheathing and bottom chord shall have a properly attached rigid ceiling. Locations shown for permanent lateral restraint of webs shall have continuous lateral restraint (CLR), installed with diagonal bracing installed on the CLR per BCSI sections B3, B7, or B10, as applicable. Apply plates to each face of truss and position as shown above and on the Joint Details, unless noted otherwise. Refer to drawings 160A-Z for standard plate positions. Refer to job's General Notes page for additional information.  
 Alpine, a division of ITW Building Components Group Inc. shall not be responsible for any deviation from this drawing, any failure to build the truss in conformance with ANSI/TPI 1, or for handling, shipping, installation and bracing of trusses. A seal on this drawing or cover page listing this drawing, indicates acceptance of professional engineering responsibility solely for the design shown. The suitability and use of this drawing for any structure is the responsibility of the Building Designer per ANSI/TPI 1 Sec.2.  
 For more information see these web sites: Alpine: alpineitw.com; TPI: tpinst.org; SBCA: sbccomponents.com; ICC: iccsafe.org; AWC: awc.org



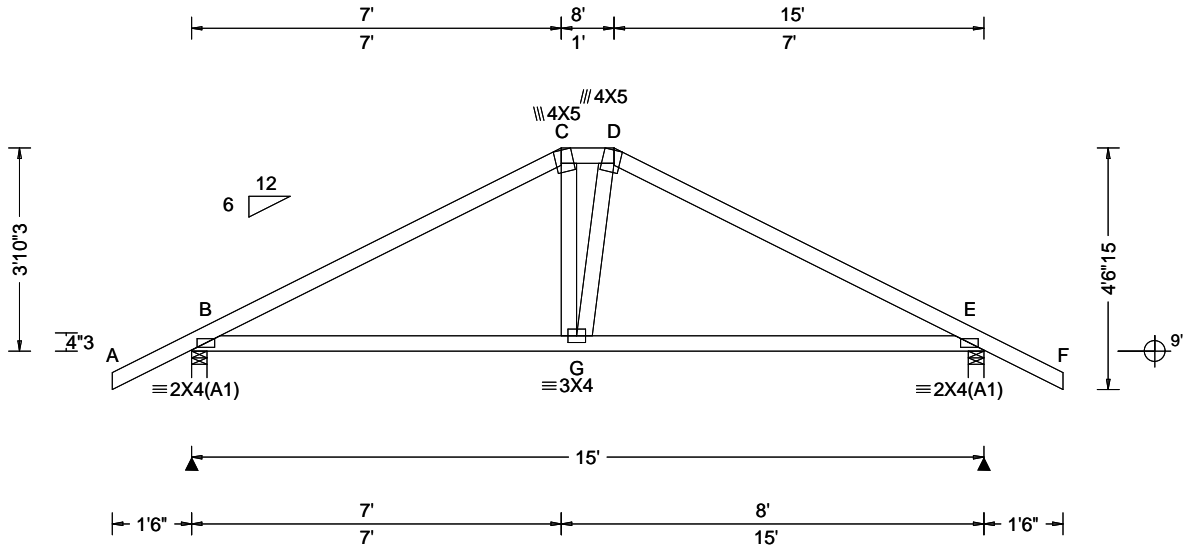

<b>Loading Criteria (psf)</b> TCLL: 20.00 TCDL: 10.00 BCLL: 0.00 BCDL: 10.00 Des Ld: 40.00 NCBCLL: 10.00 Soffit: 2.00 Load Duration: 1.25 Spacing: 24.0 "	<b>Wind Criteria</b> Wind Std: ASCE 7-22 Speed: 130 mph Enclosure: Closed Risk Category: II EXP: C Kzt: NA Mean Height: 15.00 ft TCDL: 4.2 psf BCDL: 3.0 psf MWFRS Parallel Dist: h/2 to h C&C Dist a: 3.00 ft Loc. from endwall: not in 4.50 ft GCp: 0.18 Wind Duration: 1.60	<b>Snow Criteria (Pg,Pf in PSF)</b> Pg: NA Ct: NA CAT: NA Pf: NA Ce: NA Lu: NA Cs: NA Snow Duration: NA  Building Code: FBC 8th Ed. 2023 Res. TPI Std: 2014 Rep Fac: Yes FT/RT:20(0)/10(0) Plate Type(s): WAVE	<b>Defl/CSI Criteria</b> PP Deflection in loc L/defl L/# VERT(LL): 0.014 G 999 240 VERT(CL): 0.027 G 999 180 HORZ(LL): 0.007 E - - HORZ(TL): 0.014 E - - Creep Factor: 2.0 Max TC CSI: 0.499 Max BC CSI: 0.551 Max Web CSI: 0.073  VIEW Ver: 24.02.00D.0114.10	<b>▲ Maximum Reactions (lbs)</b> Gravity Non-Gravity Loc R+ / R- / Rh / Rw / U / RL B 718 /- /- /362 /178 /90 E 718 /- /- /362 /178 /- Wind reactions based on MWFRS B Brg Wid = 3.5 Min Req = 1.5 (Truss) E Brg Wid = 3.5 Min Req = 1.5 (Truss) Bearings B & E are a rigid surface. Members not listed have forces less than 375# <b>Maximum Top Chord Forces Per Ply (lbs)</b> Chords Tens.Comp. Chords Tens. Comp. B - C 381 -851 D - E 383 -839 C - D 411 -691  <b>Maximum Bot Chord Forces Per Ply (lbs)</b> Chords Tens.Comp. Chords Tens. Comp. B - G 682 -206 G - E 673 -207
--	---	--	---	---

**Lumber**

Top chord: 2x4 SP #2;  
Bot chord: 2x4 SP #2;  
Webs: 2x4 SP #3;

**Purlins**

In lieu of structural panels use purlins to brace all flat TC @ 24" oc.

**Wind**

Wind loads based on MWFRS with additional C&C member design.  
Wind loading based on both gable and hip roof types.

**Additional Notes**

The overall height of this truss excluding overhang is 3-10-3.

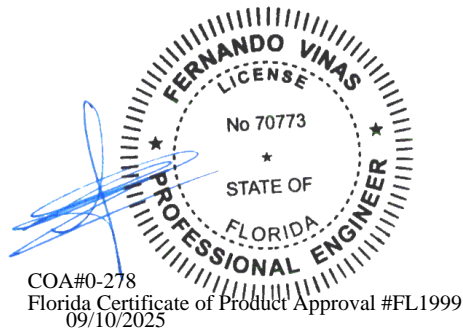

**\*\*WARNING\*\* READ AND FOLLOW ALL NOTES ON THIS DRAWING!**  
**\*\*IMPORTANT\*\* FURNISH THIS DRAWING TO ALL CONTRACTORS INCLUDING THE INSTALLERS**  
Trusses require extreme care in fabricating, handling, shipping, installing and bracing. Refer to and follow the latest edition of BCSI (Building Component Safety Information, by TPI and SBCA) for safety practices prior to performing these functions. Installers shall provide temporary bracing per BCSI. Unless noted otherwise, top chord shall have properly attached structural sheathing and bottom chord shall have a properly attached rigid ceiling. Locations shown for permanent lateral restraint of webs shall have continuous lateral restraint (CLR), installed with diagonal bracing installed on the CLR per BCSI sections B3, B7, or B10, as applicable. Apply plates to each face of truss and position as shown above and on the Joint Details, unless noted otherwise. Refer to drawings 160A-Z for standard plate positions. Refer to job's General Notes page for additional information.  
Alpine, a division of ITW Building Components Group Inc. shall not be responsible for any deviation from this drawing, any failure to build the truss in conformance with ANSI/TPI 1, or for handling, shipping, installation and bracing of trusses. A seal on this drawing or cover page listing this drawing, indicates acceptance of professional engineering responsibility solely for the design shown. The suitability and use of this drawing for any structure is the responsibility of the Building Designer per ANSI/TPI 1 Sec.2.  
For more information see these web sites: Alpine: alpineitw.com; TPI: tpinst.org; SBCA: sbcacomponents.com; ICC: iccsafe.org; AWC: awc.org



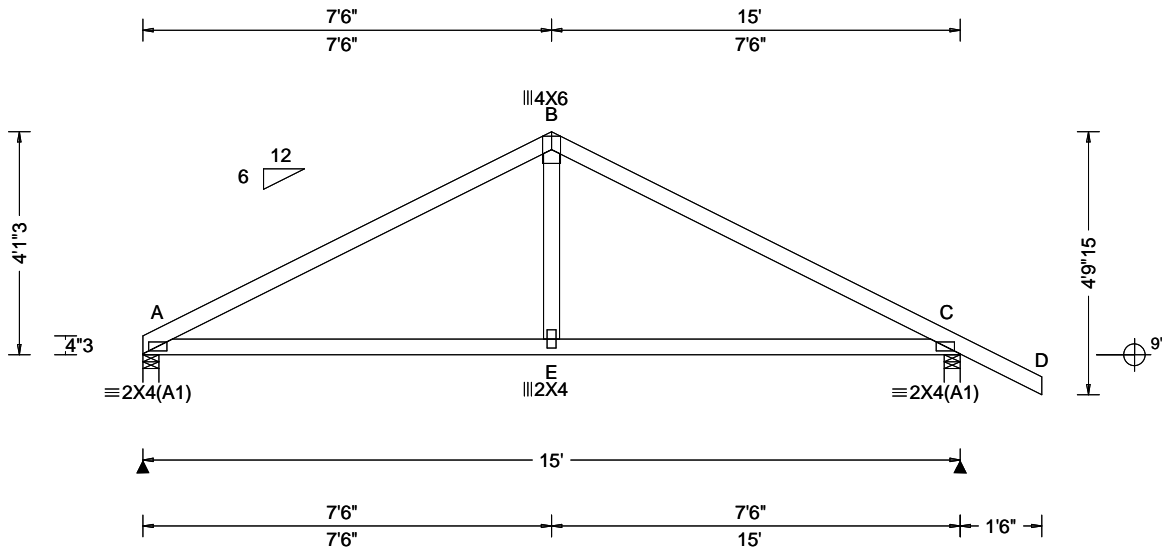

<b>Loading Criteria (psf)</b> TCLL: 20.00 TCDL: 10.00 BCLL: 0.00 BCDL: 10.00 Des Ld: 40.00 NCBCLL: 10.00 Soffit: 2.00 Load Duration: 1.25 Spacing: 24.0 "	<b>Wind Criteria</b> Wind Std: ASCE 7-22 Speed: 130 mph Enclosure: Closed Risk Category: II EXP: C Kzt: NA Mean Height: 15.00 ft TCDL: 4.2 psf BCDL: 3.0 psf MWFRS Parallel Dist: h/2 to h C&C Dist a: 3.00 ft Loc. from endwall: not in 9.00 ft GCp: 0.18 Wind Duration: 1.60	<b>Snow Criteria (Pg,Pf in PSF)</b> Pg: NA Ct: NA CAT: NA Pf: NA Ce: NA Lu: NA Cs: NA Snow Duration: NA  Building Code: FBC 8th Ed. 2023 Res. TPI Std: 2014 Rep Fac: Yes FT/RT:20(0)/10(0) Plate Type(s): WAVE	<b>Defl/CSI Criteria</b> PP Deflection in loc L/defl L/# VERT(LL): 0.016 A 999 240 VERT(CL): 0.032 A 999 180 HORZ(LL): 0.010 A - - HORZ(TL): 0.020 A - - Creep Factor: 2.0 Max TC CSI: 0.593 Max BC CSI: 0.559 Max Web CSI: 0.129  VIEW Ver: 24.02.00D.0114.10	<b>▲ Maximum Reactions (lbs)</b> Gravity Non-Gravity Loc R+ /R- /Rh /Rw /U /RL A 612 /- /- /356 /146 /111 C 724 /- /- /361 /180 /- Wind reactions based on MWFRS A Brg Wid = 3.5 Min Req = 1.5 (Truss) C Brg Wid = 3.5 Min Req = 1.5 (Truss) Bearings A & C are a rigid surface. Members not listed have forces less than 375# <b>Maximum Top Chord Forces Per Ply (lbs)</b> Chords Tens.Comp. Chords Tens. Comp. A - B 357 -860 B - C 352 -863  <b>Maximum Bot Chord Forces Per Ply (lbs)</b> Chords Tens.Comp. Chords Tens. Comp. A - E 693 -172 E - C 693 -172
--	---	--	---	---

**Lumber**

Top chord: 2x4 SP #2;  
Bot chord: 2x4 SP #2;  
Webs: 2x4 SP #3;

**Wind**

Wind loads based on MWFRS with additional C&C member design.  
Wind loading based on both gable and hip roof types.

**Additional Notes**

The overall height of this truss excluding overhang is 4-1-3.

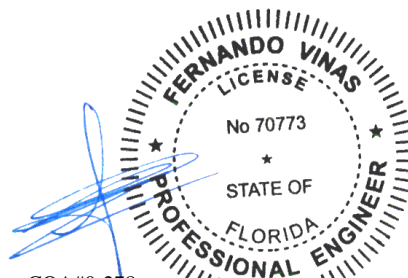

COA#0-278  
Florida Certificate of Product Approval #FL1999  
09/10/2025

**\*\*WARNING\*\* READ AND FOLLOW ALL NOTES ON THIS DRAWING!**  
**\*\*IMPORTANT\*\* FURNISH THIS DRAWING TO ALL CONTRACTORS INCLUDING THE INSTALLERS**  
Trusses require extreme care in fabricating, handling, shipping, installing and bracing. Refer to and follow the latest edition of BCSI (Building Component Safety Information, by TPI and SBCA) for safety practices prior to performing these functions. Installers shall provide temporary bracing per BCSI. Unless noted otherwise, top chord shall have properly attached structural sheathing and bottom chord shall have a properly attached rigid ceiling. Locations shown for permanent lateral restraint of webs shall have continuous lateral restraint (CLR), installed with diagonal bracing installed on the CLR per BCSI sections B3, B7, or B10, as applicable. Apply plates to each face of truss and position as shown above and on the Joint Details, unless noted otherwise. Refer to drawings 160A-Z for standard plate positions. Refer to job's General Notes page for additional information.  
Alpine, a division of ITW Building Components Group Inc. shall not be responsible for any deviation from this drawing, any failure to build the truss in conformance with ANSI/TPI 1, or for handling, shipping, installation and bracing of trusses. A seal on this drawing or cover page listing this drawing, indicates acceptance of professional engineering responsibility solely for the design shown. The suitability and use of this drawing for any structure is the responsibility of the Building Designer per ANSI/TPI 1 Sec.2.  
For more information see these web sites: Alpine: [alpineitw.com](http://alpineitw.com); TPI: [tpinst.org](http://tpinst.org); SBCA: [sbcacomponents.com](http://sbcacomponents.com); ICC: [iccsafe.org](http://iccsafe.org); AWC: [awc.org](http://awc.org)



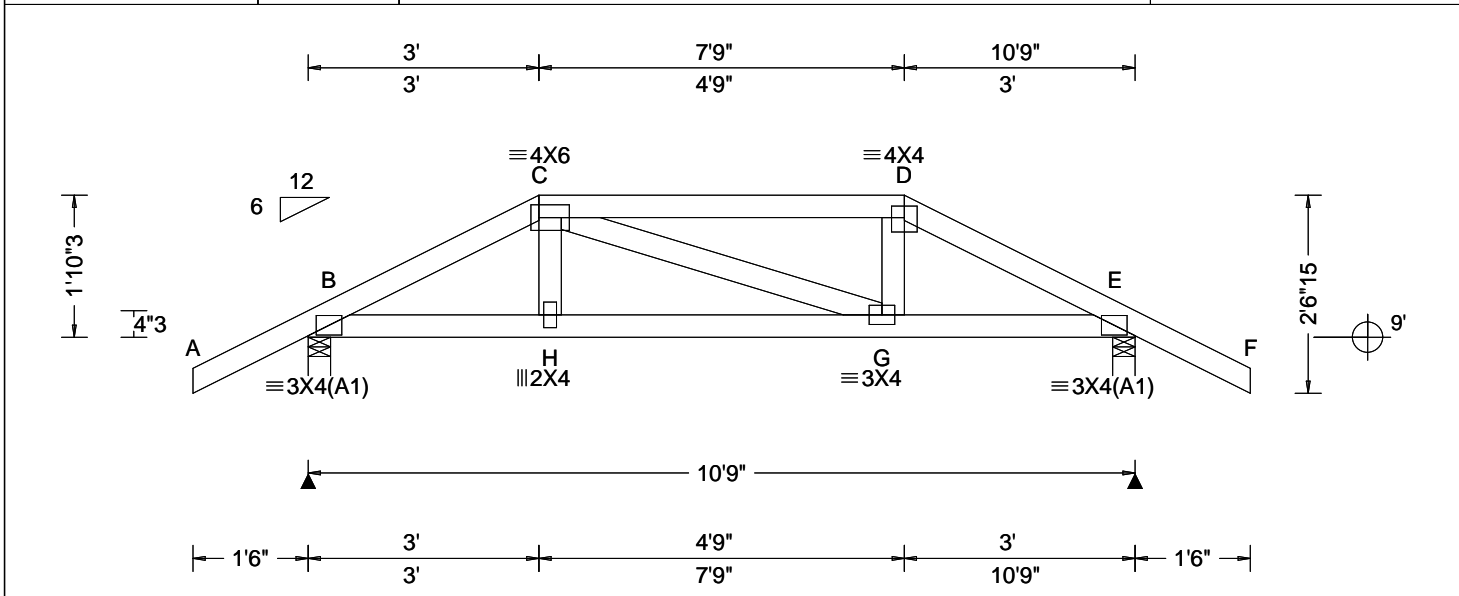

<b>Loading Criteria (psf)</b> TCLL: 20.00 TCDL: 10.00 BCLL: 0.00 BCDL: 10.00 Des Ld: 40.00 NCBCLL: 10.00 Soffit: 2.00 Load Duration: 1.25 Spacing: 24.0 "	<b>Wind Criteria</b> Wind Std: ASCE 7-22 Speed: 130 mph Enclosure: Closed Risk Category: II EXP: C Kzt: NA Mean Height: 15.00 ft TCDL: 4.2 psf BCDL: 3.0 psf MWFRS Parallel Dist: 0 to h/2 C&C Dist a: 3.00 ft Loc. from endwall: not in 4.50 ft GCpi: 0.18 Wind Duration: 1.60	<b>Snow Criteria (Pg,Pf in PSF)</b> Pg: NA Ct: NA CAT: NA Pf: NA Ce: NA Lu: NA Cs: NA Snow Duration: NA Building Code: FBC 8th Ed. 2023 Res. TPI Std: 2014 Rep Fac: Varies by Ld Case FT/RT:20(0)/10(0) Plate Type(s): WAVE	<b>Defl/CSI Criteria</b> PP Deflection in loc L/defl L/# VERT(LL): 0.019 G 999 240 VERT(CL): 0.039 G 999 180 HORZ(LL): 0.009 E - - HORZ(TL): 0.018 E - - Creep Factor: 2.0 Max TC CSI: 0.469 Max BC CSI: 0.448 Max Web CSI: 0.056 VIEW Ver: 24.02.00D.0114.10	<b>▲ Maximum Reactions (lbs)</b> <table border="1"> <thead> <tr> <th rowspan="2">Loc</th> <th colspan="3">Gravity</th> <th colspan="3">Non-Gravity</th> </tr> <tr> <th>R+</th> <th>/R-</th> <th>/Rh</th> <th>/Rw</th> <th>/U</th> <th>/RL</th> </tr> </thead> <tbody> <tr> <td>B</td> <td>740</td> <td>-/-</td> <td>-/-</td> <td>-/-</td> <td>/202</td> <td>-/-</td> </tr> <tr> <td>E</td> <td>740</td> <td>-/-</td> <td>-/-</td> <td>-/-</td> <td>/202</td> <td>-/-</td> </tr> </tbody> </table>	Loc	Gravity			Non-Gravity			R+	/R-	/Rh	/Rw	/U	/RL	B	740	-/-	-/-	-/-	/202	-/-	E	740	-/-	-/-	-/-	/202	-/-
				Loc		Gravity			Non-Gravity																						
R+	/R-	/Rh	/Rw		/U	/RL																									
B	740	-/-	-/-	-/-	/202	-/-																									
E	740	-/-	-/-	-/-	/202	-/-																									
<b>Maximum Top Chord Forces Per Ply (lbs)</b> <table border="1"> <thead> <tr> <th>Chords</th> <th>Tens.Comp.</th> <th>Chords</th> <th>Tens. Comp.</th> </tr> </thead> <tbody> <tr> <td>B - C</td> <td>274 - 1086</td> <td>D - E</td> <td>277 - 1083</td> </tr> <tr> <td>C - D</td> <td>225 - 961</td> <td></td> <td></td> </tr> </tbody> </table>				Chords	Tens.Comp.	Chords	Tens. Comp.	B - C	274 - 1086	D - E	277 - 1083	C - D	225 - 961																		
Chords	Tens.Comp.	Chords	Tens. Comp.																												
B - C	274 - 1086	D - E	277 - 1083																												
C - D	225 - 961																														

**Lumber**  
 Top chord: 2x4 SP #2;  
 Bot chord: 2x4 SP #2;  
 Webs: 2x4 SP #3;

**Special Loads**  
 ----(Lumber Dur.Fac.=1.25 / Plate Dur.Fac.=1.25)  
 TC: From 62 plf at -1.50 to 62 plf at 3.00  
 TC: From 31 plf at 3.00 to 31 plf at 7.75  
 TC: From 62 plf at 7.75 to 62 plf at 12.25  
 BC: From 4 plf at -1.50 to 4 plf at 0.00  
 BC: From 20 plf at 0.00 to 20 plf at 3.03  
 BC: From 10 plf at 3.03 to 10 plf at 7.72  
 BC: From 20 plf at 7.72 to 20 plf at 10.75  
 BC: From 4 plf at 10.75 to 4 plf at 12.25  
 TC: 116 lb Conc. Load at 3.03, 7.72  
 TC: 62 lb Conc. Load at 5.06, 5.69  
 BC: 68 lb Conc. Load at 3.03, 7.72  
 BC: 49 lb Conc. Load at 5.06, 5.69

**Purlins**  
 In lieu of structural panels use purlins to brace all flat TC @ 24" oc.

**Wind**  
 Wind loads and reactions based on MWFRS.  
 Wind loading based on both gable and hip roof types.

**Additional Notes**  
 The overall height of this truss excluding overhang is 11-0-3.

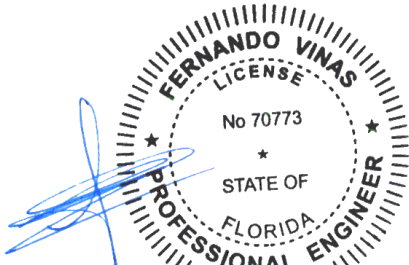

COA#0-278  
 Florida Certificate of Product Approval #FL1999  
 09/10/2025

**\*\*WARNING\*\* READ AND FOLLOW ALL NOTES ON THIS DRAWING!**  
**\*\*IMPORTANT\*\* FURNISH THIS DRAWING TO ALL CONTRACTORS INCLUDING THE INSTALLERS**  
 Trusses require extreme care in fabricating, handling, shipping, installing and bracing. Refer to and follow the latest edition of BCSI (Building Component Safety Information, by TPI and SBCA) for safety practices prior to performing these functions. Installers shall provide temporary bracing per BCSI. Unless noted otherwise, top chord shall have properly attached structural sheathing and bottom chord shall have a properly attached rigid ceiling. Locations shown for permanent lateral restraint of webs shall have continuous lateral restraint (CLR), installed with diagonal bracing installed on the CLR per BCSI sections B3, B7, or B10, as applicable. Apply plates to each face of truss and position as shown above and on the Joint Details, unless noted otherwise. Refer to drawings 160A-Z for standard plate positions. Refer to job's General Notes page for additional information.  
 Alpine, a division of ITW Building Components Group Inc. shall not be responsible for any deviation from this drawing, any failure to build the truss in conformance with ANSI/TPI 1, or for handling, shipping, installation and bracing of trusses. A seal on this drawing or cover page listing this drawing, indicates acceptance of professional engineering responsibility solely for the design shown. The suitability and use of this drawing for any structure is the responsibility of the Building Designer per ANSI/TPI 1 Sec.2.  
 For more information see these web sites: Alpine: alpineitw.com; TPI: tpinst.org; SBCA: sbcacomponents.com; ICC: iccsafe.org; AWC: awc.org



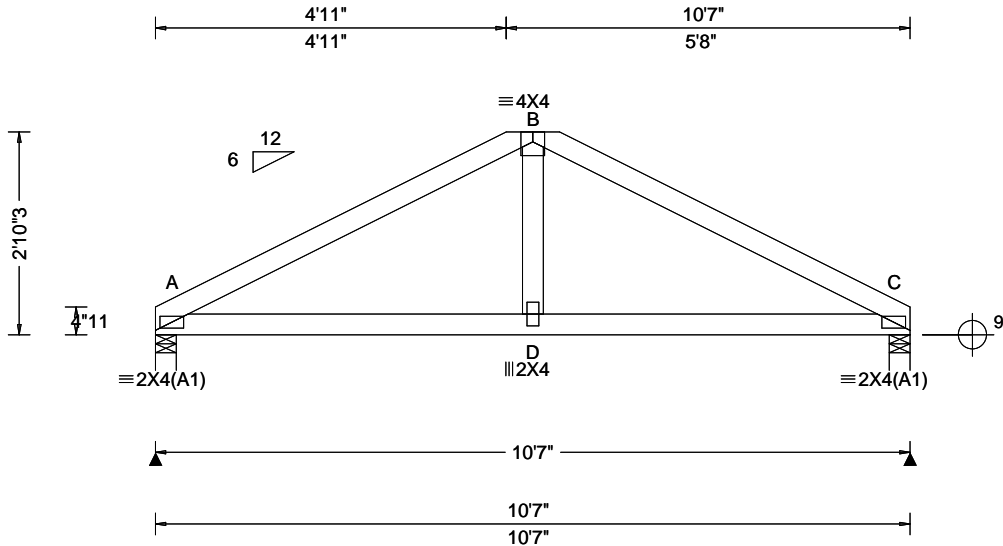

<b>Loading Criteria (psf)</b> TCLL: 20.00 TCDL: 10.00 BCLL: 0.00 BCDL: 10.00 Des Ld: 40.00 NCBCLL: 10.00 Soffit: 2.00 Load Duration: 1.25 Spacing: 24.0 "	<b>Wind Criteria</b> Wind Std: ASCE 7-22 Speed: 130 mph Enclosure: Closed Risk Category: II EXP: C Kzt: NA Mean Height: 15.00 ft TCDL: 4.2 psf BCDL: 3.0 psf MWFRS Parallel Dist: 0 to h/2 C&C Dist a: 3.00 ft Loc. from endwall: not in 4.50 ft GCpi: 0.18 Wind Duration: 1.60	<b>Snow Criteria (Pg,Pf in PSF)</b> Pg: NA Ct: NA CAT: NA Pf: NA Ce: NA Lu: NA Cs: NA Snow Duration: NA  Building Code: FBC 8th Ed. 2023 Res. TPI Std: 2014 Rep Fac: Yes FT/RT:20(0)/10(0) Plate Type(s): WAVE	<b>Defl/CSI Criteria</b> PP Deflection in loc L/defl L/# VERT(LL): 0.006 D 999 240 VERT(CL): 0.013 D 999 180 HORZ(LL): 0.003 C - - HORZ(TL): 0.007 C - - Creep Factor: 2.0 Max TC CSI: 0.258 Max BC CSI: 0.282 Max Web CSI: 0.088  VIEW Ver: 24.02.00D.0114.10	<b>▲ Maximum Reactions (lbs)</b> Gravity Non-Gravity Loc R+ / R- / Rh / Rw / U / RL A 436 /- /- /244 /97 /64 C 436 /- /- /244 /97 /- Wind reactions based on MWFRS A Brg Wid = 3.5 Min Req = 1.5 (Truss) C Brg Wid = 3.5 Min Req = 1.5 (Truss) Bearings A & C are a rigid surface. Members not listed have forces less than 375# <b>Maximum Top Chord Forces Per Ply (lbs)</b> Chords Tens.Comp. Chords Tens. Comp. A - B 299 -593 B - C 298 -593
--	--	--	---	---

**Lumber**

Top chord: 2x4 SP #2;  
Bot chord: 2x4 SP #2;  
Webs: 2x4 SP #3;

**Wind**

Wind loads based on MWFRS with additional C&C member design.  
Wind loading based on both gable and hip roof types.

**Additional Notes**

The overall height of this truss excluding overhang is 2-10-3.

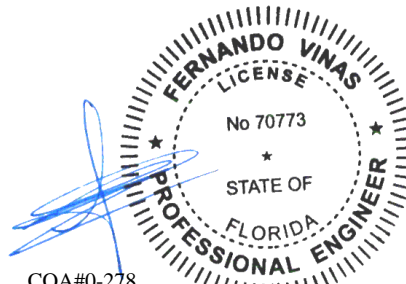

COA#0-278  
Florida Certificate of Product Approval #FL1999  
09/10/2025

**\*\*WARNING\*\* READ AND FOLLOW ALL NOTES ON THIS DRAWING!**  
**\*\*IMPORTANT\*\* FURNISH THIS DRAWING TO ALL CONTRACTORS INCLUDING THE INSTALLERS**  
Trusses require extreme care in fabricating, handling, shipping, installing and bracing. Refer to and follow the latest edition of BCSI (Building Component Safety Information, by TPI and SBCA) for safety practices prior to performing these functions. Installers shall provide temporary bracing per BCSI. Unless noted otherwise, top chord shall have properly attached structural sheathing and bottom chord shall have a properly attached rigid ceiling. Locations shown for permanent lateral restraint of webs shall have continuous lateral restraint (CLR), installed with diagonal bracing installed on the CLR per BCSI sections B3, B7, or B10, as applicable. Apply plates to each face of truss and position as shown above and on the Joint Details, unless noted otherwise. Refer to drawings 160A-Z for standard plate positions. Refer to job's General Notes page for additional information.  
Alpine, a division of ITW Building Components Group Inc. shall not be responsible for any deviation from this drawing, any failure to build the truss in conformance with ANSI/TPI 1, or for handling, shipping, installation and bracing of trusses. A seal on this drawing or cover page listing this drawing, indicates acceptance of professional engineering responsibility solely for the design shown. The suitability and use of this drawing for any structure is the responsibility of the Building Designer per ANSI/TPI 1 Sec.2.  
For more information see these web sites: Alpine: [alpineitw.com](http://alpineitw.com); TPI: [tpinst.org](http://tpinst.org); SBCA: [sbcacomponents.com](http://sbcacomponents.com); ICC: [iccsafe.org](http://iccsafe.org); AWC: [awc.org](http://awc.org)



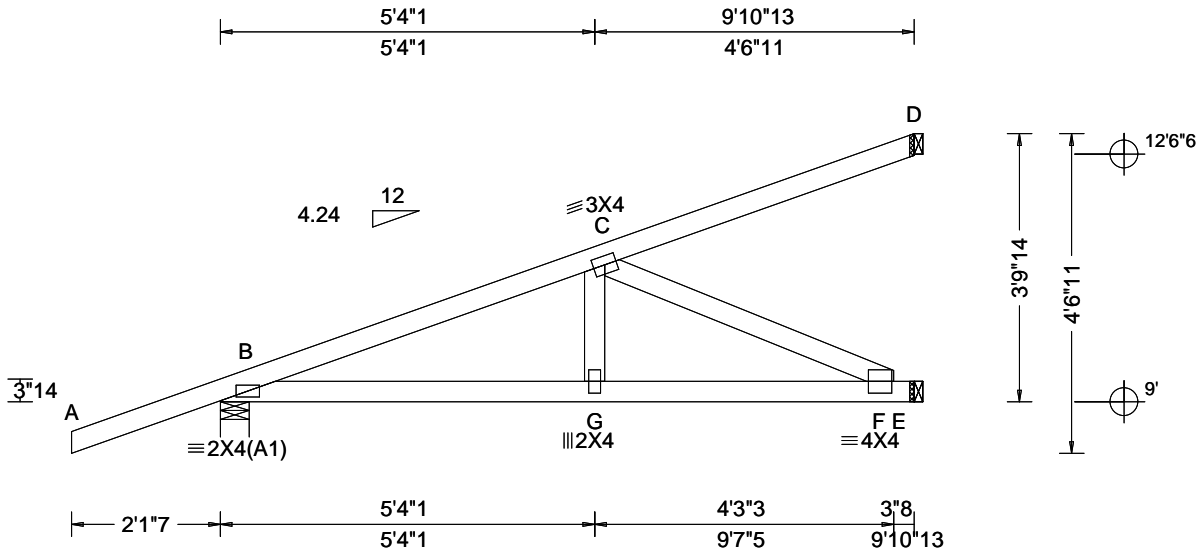

<b>Loading Criteria (psf)</b> TCLL: 20.00 TCDL: 10.00 BCLL: 0.00 BCDL: 10.00 Des Ld: 40.00 NCBCLL: 0.00 Soffit: 2.00 Load Duration: 1.25 Spacing: 24.0 "	<b>Wind Criteria</b> Wind Std: ASCE 7-22 Speed: 130 mph Enclosure: Closed Risk Category: II EXP: C Kzt: NA Mean Height: 15.00 ft TCDL: 4.2 psf BCDL: 3.0 psf MWFRS Parallel Dist: 0 to h/2 C&C Dist a: 3.00 ft Loc. from endwall: NA GCpi: 0.18 Wind Duration: 1.60	<b>Snow Criteria (Pg,Pf in PSF)</b> Pg: NA Ct: NA CAT: NA Pf: NA Ce: NA Lu: NA Cs: NA Snow Duration: NA Building Code: FBC 8th Ed. 2023 Res. TPI Std: 2014 Rep Fac: No FT/RT:20(0)/10(0) Plate Type(s): WAVE	<b>Defl/CSI Criteria</b> PP Deflection in loc L/defl L/# VERT(LL): 0.022 G 999 240 VERT(CL): 0.044 G 999 180 HORZ(LL): 0.005 F - - HORZ(TL): 0.011 F - - Creep Factor: 2.0 Max TC CSI: 0.594 Max BC CSI: 0.533 Max Web CSI: 0.333 VIEW Ver: 24.02.00D.0114.10	<b>▲ Maximum Reactions (lbs)</b> <table border="1"> <thead> <tr> <th rowspan="2">Loc</th> <th colspan="3">Gravity</th> <th colspan="3">Non-Gravity</th> </tr> <tr> <th>R+</th> <th>/R-</th> <th>/Rh</th> <th>/Rw</th> <th>/U</th> <th>/RL</th> </tr> </thead> <tbody> <tr> <td>B</td> <td>461</td> <td>-</td> <td>-</td> <td>-</td> <td>/123</td> <td>-</td> </tr> <tr> <td>E</td> <td>374</td> <td>-</td> <td>-</td> <td>-</td> <td>/49</td> <td>-</td> </tr> <tr> <td>D</td> <td>247</td> <td>-</td> <td>-</td> <td>-</td> <td>/102</td> <td>-</td> </tr> </tbody> </table>						Loc	Gravity			Non-Gravity			R+	/R-	/Rh	/Rw	/U	/RL	B	461	-	-	-	/123	-	E	374	-	-	-	/49	-	D	247	-	-	-	/102	-
				Loc	Gravity			Non-Gravity																																			
R+	/R-	/Rh	/Rw		/U	/RL																																					
B	461	-	-	-	/123	-																																					
E	374	-	-	-	/49	-																																					
D	247	-	-	-	/102	-																																					
<b>Maximum Top Chord Forces Per Ply (lbs)</b> <table border="1"> <thead> <tr> <th>Chords</th> <th>Tens.</th> <th>Comp.</th> </tr> </thead> <tbody> <tr> <td>B - C</td> <td>177</td> <td>-739</td> </tr> </tbody> </table>				Chords	Tens.	Comp.	B - C	177	-739	<b>Maximum Bot Chord Forces Per Ply (lbs)</b> <table border="1"> <thead> <tr> <th>Chords</th> <th>Tens.</th> <th>Comp.</th> <th>Chords</th> <th>Tens.</th> <th>Comp.</th> </tr> </thead> <tbody> <tr> <td>B - G</td> <td>675</td> <td>-159</td> <td>G - F</td> <td>668</td> <td>-161</td> </tr> </tbody> </table>			Chords	Tens.	Comp.	Chords	Tens.	Comp.	B - G	675	-159	G - F	668	-161																			
Chords	Tens.	Comp.																																									
B - C	177	-739																																									
Chords	Tens.	Comp.	Chords	Tens.	Comp.																																						
B - G	675	-159	G - F	668	-161																																						

**Lumber**

Top chord: 2x4 SP #2;  
 Bot chord: 2x4 SP #2;  
 Webs: 2x4 SP #3;

**Loading**

Hipjack supports 7-0-0 setback jacks with no webs.

**Wind**

Wind loads and reactions based on MWFRS.  
 Wind loading based on both gable and hip roof types.

**Additional Notes**

The overall height of this truss excluding overhang is 3-9-14.

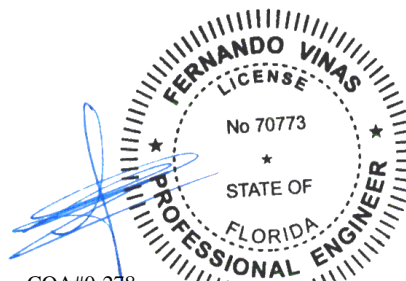

COA#0-278  
 Florida Certificate of Product Approval #FL1999  
 09/10/2025

**\*\*WARNING\*\* READ AND FOLLOW ALL NOTES ON THIS DRAWING!**  
**\*\*IMPORTANT\*\* FURNISH THIS DRAWING TO ALL CONTRACTORS INCLUDING THE INSTALLERS**  
 Trusses require extreme care in fabricating, handling, shipping, installing and bracing. Refer to and follow the latest edition of BCSI (Building Component Safety Information, by TPI and SBCA) for safety practices prior to performing these functions. Installers shall provide temporary bracing per BCSI. Unless noted otherwise, top chord shall have properly attached structural sheathing and bottom chord shall have a properly attached rigid ceiling. Locations shown for permanent lateral restraint of webs shall have continuous lateral restraint (CLR), installed with diagonal bracing installed on the CLR per BCSI sections B3, B7, or B10, as applicable. Apply plates to each face of truss and position as shown above and on the Joint Details, unless noted otherwise. Refer to drawings 160A-Z for standard plate positions. Refer to job's General Notes page for additional information.  
 Alpine, a division of ITW Building Components Group Inc. shall not be responsible for any deviation from this drawing, any failure to build the truss in conformance with ANSI/TPI 1, or for handling, shipping, installation and bracing of trusses. A seal on this drawing or cover page listing this drawing, indicates acceptance of professional engineering responsibility solely for the design shown. The suitability and use of this drawing for any structure is the responsibility of the Building Designer per ANSI/TPI 1 Sec.2.  
 For more information see these web sites: Alpine: alpineitw.com; TPI: tpinst.org; SBCA: sbccomponents.com; ICC: iccsafe.org; AWC: awc.org



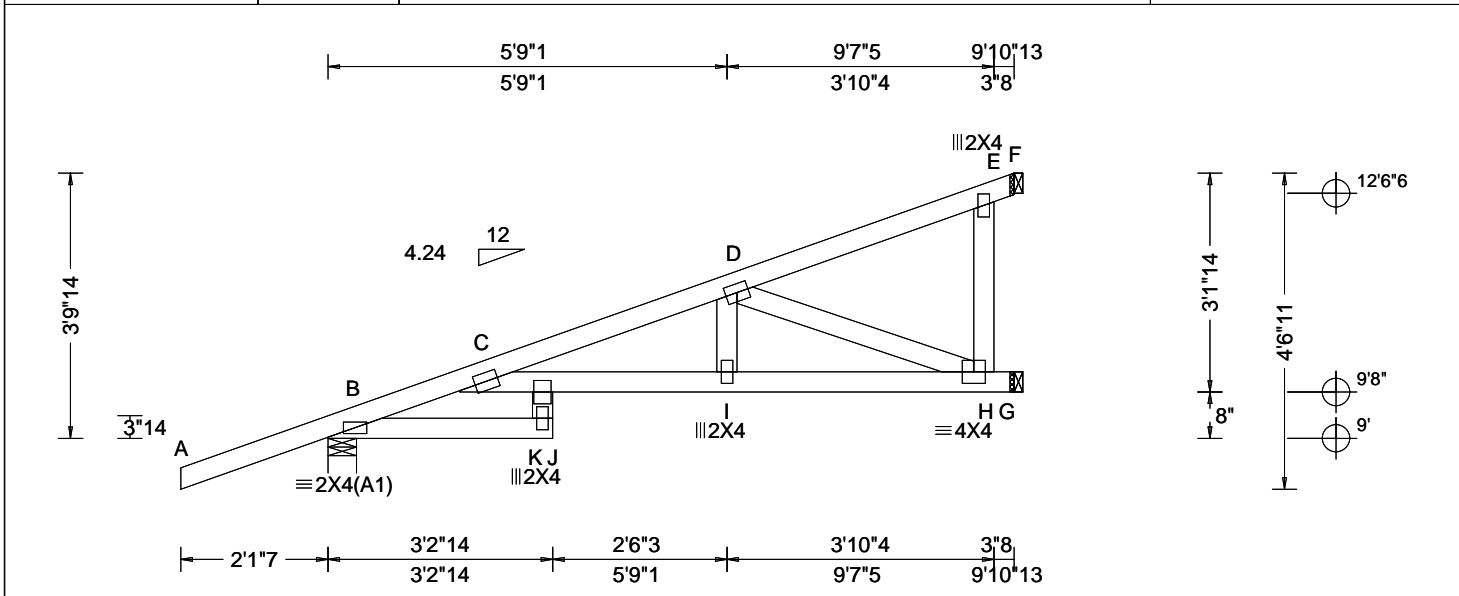

<b>Loading Criteria (psf)</b> TCCL: 20.00 TCCL: 10.00 BCLL: 0.00 BCDL: 10.00 Des Ld: 40.00 NCBCLL: 0.00 Soffit: 2.00 Load Duration: 1.25 Spacing: 24.0 "	<b>Wind Criteria</b> Wind Std: ASCE 7-22 Speed: 130 mph Enclosure: Closed Risk Category: II EXP: C Kzt: NA Mean Height: 15.00 ft TCCL: 4.2 psf BCDL: 3.0 psf MWFRS Parallel Dist: 0 to h/2 C&C Dist a: 3.00 ft Loc. from endwall: NA GCpi: 0.18 Wind Duration: 1.60	<b>Snow Criteria (Pg,Pf in PSF)</b> Pg: NA Ct: NA CAT: NA Pf: NA Ce: NA Lu: NA Cs: NA Snow Duration: NA Building Code: FBC 8th Ed. 2023 Res. TPI Std: 2014 Rep Fac: No FT/RT:20(0)/10(0) Plate Type(s): WAVE	<b>Defl/CSI Criteria</b> PP Deflection in loc L/defl L/# VERT(LL): 0.116 J 999 240 VERT(CL): 0.254 J 461 180 HORZ(LL): 0.050 H - - HORZ(TL): 0.108 H - - Creep Factor: 2.0 Max TC CSI: 0.759 Max BC CSI: 0.528 Max Web CSI: 0.329 VIEW Ver: 24.02.00D.0114.10	<b>▲ Maximum Reactions (lbs)</b> <table border="1" style="width:100%; border-collapse: collapse;"> <thead> <tr> <th rowspan="2">Loc</th> <th colspan="3">Gravity</th> <th colspan="3">Non-Gravity</th> </tr> <tr> <th>R+</th> <th>/R-</th> <th>/Rh</th> <th>/Rw</th> <th>/U</th> <th>/RL</th> </tr> </thead> <tbody> <tr> <td>B</td> <td>461</td> <td>-</td> <td>-</td> <td>-</td> <td>/123</td> <td>-</td> </tr> <tr> <td>G</td> <td>377</td> <td>-</td> <td>-</td> <td>-</td> <td>/141</td> <td>-</td> </tr> <tr> <td>F</td> <td>245</td> <td>-</td> <td>-</td> <td>-</td> <td>/9</td> <td>-</td> </tr> </tbody> </table> Wind reactions based on MWFRS B Brg Wid = 4.9 Min Req = 1.5 (Truss) G Brg Wid = 1.5 Min Req = - F Brg Wid = 1.5 Min Req = - Bearing B is a rigid surface. Members not listed have forces less than 375# <b>Maximum Top Chord Forces Per Ply (lbs)</b> Chords Tens.Comp.	Loc	Gravity			Non-Gravity			R+	/R-	/Rh	/Rw	/U	/RL	B	461	-	-	-	/123	-	G	377	-	-	-	/141	-	F	245	-	-	-	/9	-
Loc	Gravity			Non-Gravity																																		
	R+	/R-	/Rh	/Rw	/U	/RL																																
B	461	-	-	-	/123	-																																
G	377	-	-	-	/141	-																																
F	245	-	-	-	/9	-																																

<b>Lumber</b> Top chord: 2x4 SP #2; Bot chord: 2x4 SP #2; Webs: 2x4 SP #3; <b>Plating Notes</b> All plates are 3X4 except as noted.	<b>Maximum Bot Chord Forces Per Ply (lbs)</b> <table border="1" style="width:100%; border-collapse: collapse;"> <thead> <tr> <th>Chords</th> <th>Tens.Comp.</th> <th>Chords</th> <th>Tens. Comp.</th> </tr> </thead> <tbody> <tr> <td>C - K</td> <td>825 -191</td> <td>I - H</td> <td>960 -231</td> </tr> <tr> <td>K - I</td> <td>970 -229</td> <td></td> <td></td> </tr> </tbody> </table>	Chords	Tens.Comp.	Chords	Tens. Comp.	C - K	825 -191	I - H	960 -231	K - I	970 -229		
Chords	Tens.Comp.	Chords	Tens. Comp.										
C - K	825 -191	I - H	960 -231										
K - I	970 -229												

<b>Loading</b> Hipjack supports 7-0-0 setback jacks with no webs. <b>Wind</b> Wind loads and reactions based on MWFRS. Wind loading based on both gable and hip roof types.	<b>Maximum Web Forces Per Ply (lbs)</b> <table border="1" style="width:100%; border-collapse: collapse;"> <thead> <tr> <th>Webs</th> <th>Tens.Comp.</th> </tr> </thead> <tbody> <tr> <td>D - H</td> <td>243 -1010</td> </tr> </tbody> </table>	Webs	Tens.Comp.	D - H	243 -1010
Webs	Tens.Comp.				
D - H	243 -1010				

**Additional Notes**  
 The overall height of this truss excluding overhang is 3-9-14.

Laterally brace chord above/below filler at 24" OC (or as designed) including a lateral brace on chord directly above/ below both ends of filler (if no rigid diaphragm exists at that point)

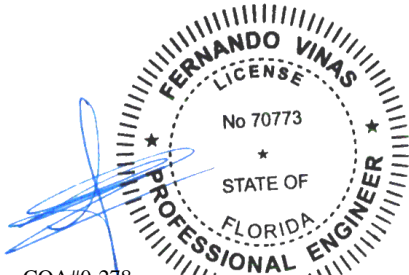

COA#0-278  
 Florida Certificate of Product Approval #FL1999  
 09/10/2025

**\*\*WARNING\*\* READ AND FOLLOW ALL NOTES ON THIS DRAWING!**  
**\*\*IMPORTANT\*\* FURNISH THIS DRAWING TO ALL CONTRACTORS INCLUDING THE INSTALLERS**  
 Trusses require extreme care in fabricating, handling, shipping, installing and bracing. Refer to and follow the latest edition of BCSI (Building Component Safety Information, by TPI and SBCA) for safety practices prior to performing these functions. Installers shall provide temporary bracing per BCSI. Unless noted otherwise, top chord shall have properly attached structural sheathing and bottom chord shall have a properly attached rigid ceiling. Locations shown for permanent lateral restraint of webs shall have continuous lateral restraint (CLR), installed with diagonal bracing installed on the CLR per BCSI sections B3, B7, or B10, as applicable. Apply plates to each face of truss and position as shown above and on the Joint Details, unless noted otherwise. Refer to drawings 160A-Z for standard plate positions. Refer to job's General Notes page for additional information.  
 Alpine, a division of ITW Building Components Group Inc. shall not be responsible for any deviation from this drawing, any failure to build the truss in conformance with ANSI/TPI 1, or for handling, shipping, installation and bracing of trusses. A seal on this drawing or cover page listing this drawing, indicates acceptance of professional engineering responsibility solely for the design shown. The suitability and use of this drawing for any structure is the responsibility of the Building Designer per ANSI/TPI 1 Sec.2.  
 For more information see these web sites: Alpine: alpineitw.com; TPI: tpinst.org; SBCA: sbcacomponents.com; ICC: iccsafe.org; AWC: awc.org



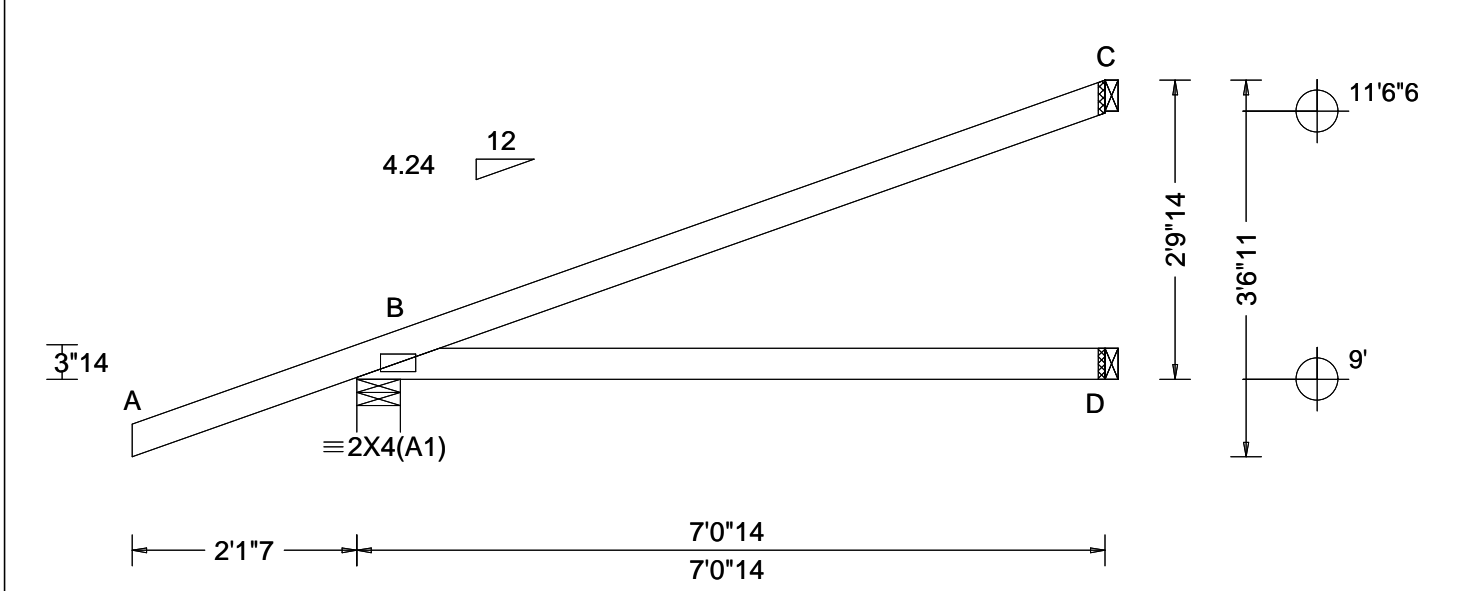

<b>Loading Criteria (psf)</b> TCLL: 20.00 TCCL: 10.00 BCLL: 0.00 BCDL: 10.00 Des Ld: 40.00 NCBCLL: 0.00 Soffit: 2.00 Load Duration: 1.25 Spacing: 24.0 "	<b>Wind Criteria</b> Wind Std: ASCE 7-22 Speed: 130 mph Enclosure: Closed Risk Category: II EXP: C Kzt: NA Mean Height: 15.00 ft TCCL: 4.2 psf BCDL: 3.0 psf MWFRS Parallel Dist: 0 to h/2 C&C Dist a: 3.00 ft Loc. from endwall: NA GCp: 0.18 Wind Duration: 1.60	<b>Snow Criteria (Pg,Pf in PSF)</b> Pg: NA Ct: NA CAT: NA Pf: NA Ce: NA Lu: NA Cs: NA Snow Duration: NA Building Code: FBC 8th Ed. 2023 Res. TPI Std: 2014 Rep Fac: No FT/RT:20(0)/10(0) Plate Type(s): WAVE	<b>Defl/CSI Criteria</b> PP Deflection in loc L/defl L/# VERT(LL): NA VERT(CL): NA HORZ(LL): 0.009 B - - HORZ(TL): 0.017 B - - Creep Factor: 2.0 Max TC CSI: 0.700 Max BC CSI: 0.368 Max Web CSI: 0.000 VIEW Ver: 24.02.00D.0114.10	<b>▲ Maximum Reactions (lbs)</b> <table style="width:100%; border-collapse: collapse;"> <thead> <tr> <th rowspan="2">Loc</th> <th colspan="3">Gravity</th> <th colspan="3">Non-Gravity</th> </tr> <tr> <th>R+</th> <th>/R-</th> <th>/Rh</th> <th>/Rw</th> <th>/U</th> <th>/RL</th> </tr> </thead> <tbody> <tr> <td>B</td> <td>307</td> <td>-</td> <td>-</td> <td>-</td> <td>/86</td> <td>-</td> </tr> <tr> <td>D</td> <td>82</td> <td>-</td> <td>-</td> <td>/15</td> <td>-</td> <td>-</td> </tr> <tr> <td>C</td> <td>212</td> <td>-</td> <td>-</td> <td>-</td> <td>/85</td> <td>-</td> </tr> </tbody> </table> <p>Wind reactions based on MWFRS          B Brg Wid = 4.9 Min Req = 1.5 (Truss)          D Brg Wid = 1.5 Min Req = -          C Brg Wid = 1.5 Min Req = -          Bearing B is a rigid surface.          Members not listed have forces less than 375#</p>	Loc	Gravity			Non-Gravity			R+	/R-	/Rh	/Rw	/U	/RL	B	307	-	-	-	/86	-	D	82	-	-	/15	-	-	C	212	-	-	-	/85	-
Loc	Gravity			Non-Gravity																																		
	R+	/R-	/Rh	/Rw	/U	/RL																																
B	307	-	-	-	/86	-																																
D	82	-	-	/15	-	-																																
C	212	-	-	-	/85	-																																

**Lumber**

Top chord: 2x4 SP #2;  
 Bot chord: 2x4 SP #2;

**Loading**

Hipjack supports 5-0-0 setback jacks with no webs.

**Wind**

Wind loads and reactions based on MWFRS.  
 Wind loading based on both gable and hip roof types.

**Additional Notes**

The overall height of this truss excluding overhang is 2-9-14.

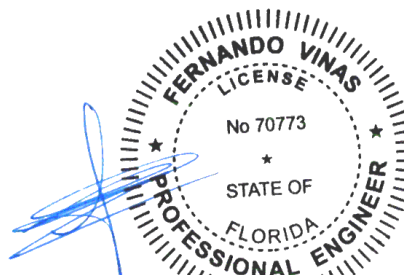

COA#0-278  
 Florida Certificate of Product Approval #FL1999  
 09/10/2025

**\*\*WARNING\*\* READ AND FOLLOW ALL NOTES ON THIS DRAWING!**  
**\*\*IMPORTANT\*\* FURNISH THIS DRAWING TO ALL CONTRACTORS INCLUDING THE INSTALLERS**  
 Trusses require extreme care in fabricating, handling, shipping, installing and bracing. Refer to and follow the latest edition of BCSI (Building Component Safety Information, by TPI and SBCA) for safety practices prior to performing these functions. Installers shall provide temporary bracing per BCSI. Unless noted otherwise, top chord shall have properly attached structural sheathing and bottom chord shall have a properly attached rigid ceiling. Locations shown for permanent lateral restraint of webs shall have continuous lateral restraint (CLR), installed with diagonal bracing installed on the CLR per BCSI sections B3, B7, or B10, as applicable. Apply plates to each face of truss and position as shown above and on the Joint Details, unless noted otherwise. Refer to drawings 160A-Z for standard plate positions. Refer to job's General Notes page for additional information.  
 Alpine, a division of ITW Building Components Group Inc. shall not be responsible for any deviation from this drawing, any failure to build the truss in conformance with ANSI/TPI 1, or for handling, shipping, installation and bracing of trusses. A seal on this drawing or cover page listing this drawing, indicates acceptance of professional engineering responsibility solely for the design shown. The suitability and use of this drawing for any structure is the responsibility of the Building Designer per ANSI/TPI 1 Sec.2.  
 For more information see these web sites: Alpine: alpineitw.com; TPI: tpinst.org; SBCA: sbccomponents.com; ICC: iccsafe.org; AWC: awc.org



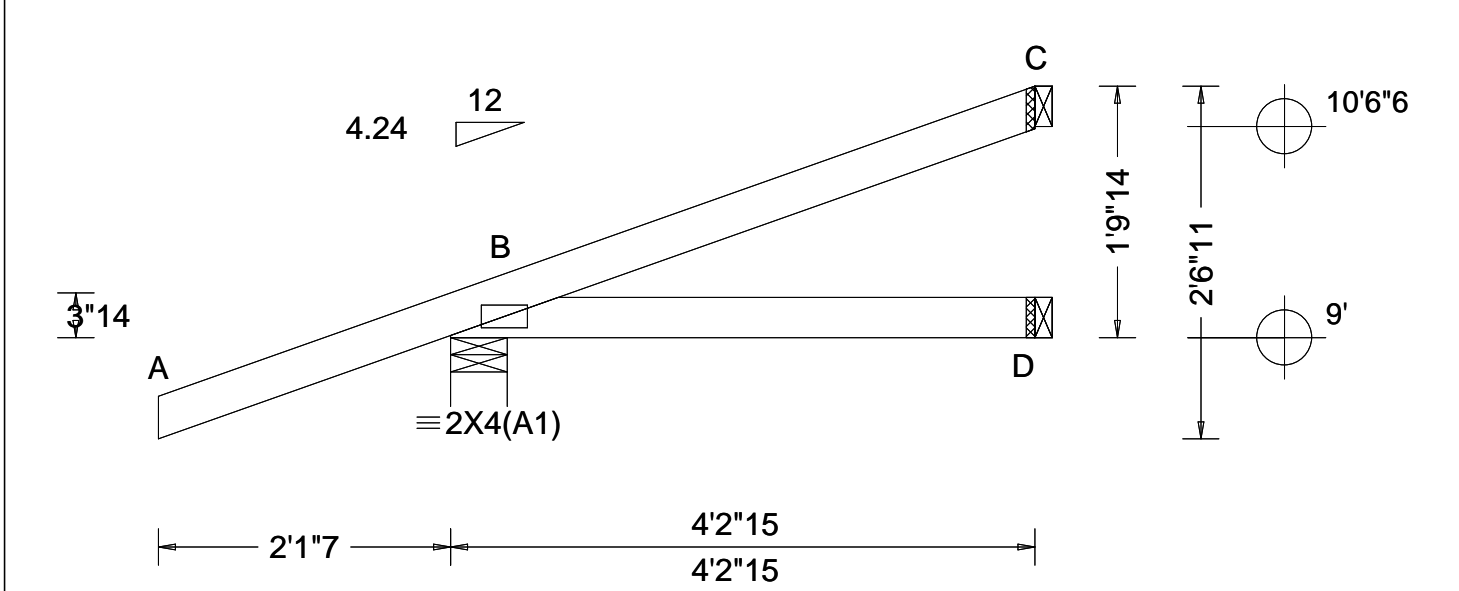

<b>Loading Criteria (psf)</b> TCCL: 20.00 TCDL: 10.00 BCCL: 0.00 BCDL: 10.00 Des Ld: 40.00 NCBCLL: 0.00 Soffit: 2.00 Load Duration: 1.25 Spacing: 24.0 "	<b>Wind Criteria</b> Wind Std: ASCE 7-22 Speed: 130 mph Enclosure: Closed Risk Category: II EXP: C Kzt: NA Mean Height: 15.00 ft TCCL: 4.2 psf BCDL: 3.0 psf MWFRS Parallel Dist: 0 to h/2 C&C Dist a: 3.00 ft Loc. from endwall: NA GCp: 0.18 Wind Duration: 1.60	<b>Snow Criteria (Pg,Pf in PSF)</b> Pg: NA Ct: NA CAT: NA Pf: NA Ce: NA Lu: NA Cs: NA Snow Duration: NA Building Code: FBC 8th Ed. 2023 Res. TPI Std: 2014 Rep Fac: No FT/RT:20(0)/10(0) Plate Type(s): WAVE	<b>Defl/CSI Criteria</b> PP Deflection in loc L/defl L/# VERT(LL): NA VERT(CL): NA HORZ(LL): -0.002 B - - HORZ(TL): 0.003 B - - Creep Factor: 2.0 Max TC CSI: 0.405 Max BC CSI: 0.112 Max Web CSI: 0.000 VIEW Ver: 24.02.00D.0114.10	<b>▲ Maximum Reactions (lbs)</b> <table border="1"> <thead> <tr> <th rowspan="2">Loc</th> <th colspan="3">Gravity</th> <th colspan="3">Non-Gravity</th> </tr> <tr> <th>R+</th> <th>/R-</th> <th>/Rh</th> <th>/Rw</th> <th>/U</th> <th>/RL</th> </tr> </thead> <tbody> <tr> <td>B</td> <td>218</td> <td>/-</td> <td>/-</td> <td>/-</td> <td>/66</td> <td>/-</td> </tr> <tr> <td>D</td> <td>19</td> <td>/-</td> <td>/-</td> <td>/10</td> <td>/-</td> <td>/-</td> </tr> <tr> <td>C</td> <td>53</td> <td>/-</td> <td>/-</td> <td>/-</td> <td>/23</td> <td>/-</td> </tr> </tbody> </table>	Loc	Gravity			Non-Gravity			R+	/R-	/Rh	/Rw	/U	/RL	B	218	/-	/-	/-	/66	/-	D	19	/-	/-	/10	/-	/-	C	53	/-	/-	/-	/23	/-
				Loc		Gravity			Non-Gravity																													
R+	/R-	/Rh	/Rw		/U	/RL																																
B	218	/-	/-	/-	/66	/-																																
D	19	/-	/-	/10	/-	/-																																
C	53	/-	/-	/-	/23	/-																																
Wind reactions based on MWFRS B Brg Wid = 4.9 Min Req = 1.5 (Truss) D Brg Wid = 1.5 Min Req = - C Brg Wid = 1.5 Min Req = - Bearing B is a rigid surface. Members not listed have forces less than 375#																																						

**Lumber**

Top chord: 2x4 SP #2;  
 Bot chord: 2x4 SP #2;

**Loading**

Hipjack supports 3-0-0 setback jacks with no webs.

**Wind**

Wind loads and reactions based on MWFRS.  
 Wind loading based on both gable and hip roof types.

**Additional Notes**

The overall height of this truss excluding overhang is 1-9-14.

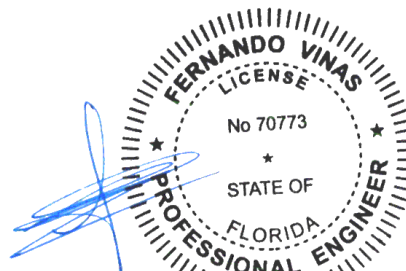

COA#0-278  
 Florida Certificate of Product Approval #FL1999  
 09/10/2025

**\*\*WARNING\*\* READ AND FOLLOW ALL NOTES ON THIS DRAWING!**  
**\*\*IMPORTANT\*\* FURNISH THIS DRAWING TO ALL CONTRACTORS INCLUDING THE INSTALLERS**  
 Trusses require extreme care in fabricating, handling, shipping, installing and bracing. Refer to and follow the latest edition of BCSI (Building Component Safety Information, by TPI and SBCA) for safety practices prior to performing these functions. Installers shall provide temporary bracing per BCSI. Unless noted otherwise, top chord shall have properly attached structural sheathing and bottom chord shall have a properly attached rigid ceiling. Locations shown for permanent lateral restraint of webs shall have continuous lateral restraint (CLR), installed with diagonal bracing installed on the CLR per BCSI sections B3, B7, or B10, as applicable. Apply plates to each face of truss and position as shown above and on the Joint Details, unless noted otherwise. Refer to drawings 160A-Z for standard plate positions. Refer to job's General Notes page for additional information.  
 Alpine, a division of ITW Building Components Group Inc. shall not be responsible for any deviation from this drawing, any failure to build the truss in conformance with ANSI/TPI 1, or for handling, shipping, installation and bracing of trusses. A seal on this drawing or cover page listing this drawing, indicates acceptance of professional engineering responsibility solely for the design shown. The suitability and use of this drawing for any structure is the responsibility of the Building Designer per ANSI/TPI 1 Sec.2.  
 For more information see these web sites: Alpine: alpineitw.com; TPI: tpinst.org; SBCA: sbccomponents.com; ICC: iccsafe.org; AWC: awc.org



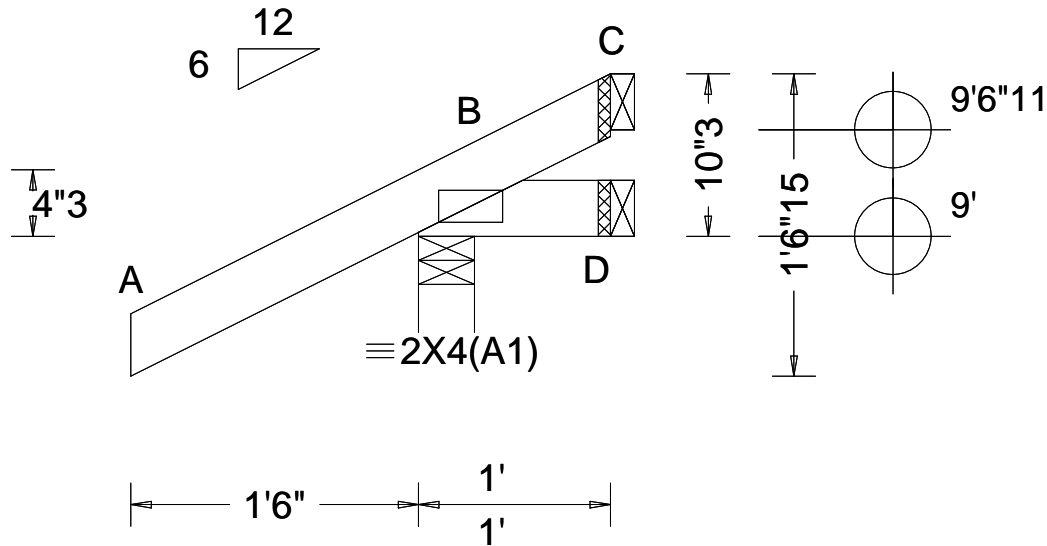

<b>Loading Criteria (psf)</b> TCLL: 20.00 TCDL: 10.00 BCLL: 0.00 BCDL: 10.00 Des Ld: 40.00 NCBCLL: 10.00 Soffit: 2.00 Load Duration: 1.25 Spacing: 24.0 "	<b>Wind Criteria</b> Wind Std: ASCE 7-22 Speed: 130 mph Enclosure: Closed Risk Category: II EXP: C Kzt: NA Mean Height: 15.00 ft TCDL: 4.2 psf BCDL: 3.0 psf MWFRS Parallel Dist: 0 to h/2 C&C Dist a: 3.00 ft Loc. from endwall: Any GCp: 0.18 Wind Duration: 1.60	<b>Snow Criteria (Pg,Pf in PSF)</b> Pg: NA Ct: NA CAT: NA Pf: NA Ce: NA Lu: NA Cs: NA Snow Duration: NA Building Code: FBC 8th Ed. 2023 Res. TPI Std: 2014 Rep Fac: Yes FT/RT:20(0)/10(0) Plate Type(s): WAVE	<b>Defl/CSI Criteria</b> PP Deflection in loc L/defl L/# VERT(LL): NA VERT(CL): NA HORZ(LL): -0.000 B - - HORZ(TL): 0.001 B - - Creep Factor: 2.0 Max TC CSI: 0.246 Max BC CSI: 0.034 Max Web CSI: 0.000 VIEW Ver: 24.02.00D.0114.10	<b>▲ Maximum Reactions (lbs)</b> <table border="1"> <thead> <tr> <th rowspan="2">Loc</th> <th colspan="3">Gravity</th> <th colspan="3">Non-Gravity</th> </tr> <tr> <th>R+</th> <th>/R-</th> <th>/Rh</th> <th>/Rw</th> <th>/U</th> <th>/RL</th> </tr> </thead> <tbody> <tr> <td>B</td> <td>254</td> <td>/-</td> <td>/-</td> <td>/75</td> <td>/79</td> <td>/38</td> </tr> <tr> <td>D</td> <td>4</td> <td>/-18</td> <td>/-</td> <td>/15</td> <td>/0</td> <td>/-</td> </tr> <tr> <td>C</td> <td>-</td> <td>/-53</td> <td>/-</td> <td>/35</td> <td>/9</td> <td>/-</td> </tr> </tbody> </table>	Loc	Gravity			Non-Gravity			R+	/R-	/Rh	/Rw	/U	/RL	B	254	/-	/-	/75	/79	/38	D	4	/-18	/-	/15	/0	/-	C	-	/-53	/-	/35	/9	/-
				Loc		Gravity			Non-Gravity																													
R+	/R-	/Rh	/Rw		/U	/RL																																
B	254	/-	/-	/75	/79	/38																																
D	4	/-18	/-	/15	/0	/-																																
C	-	/-53	/-	/35	/9	/-																																
Wind reactions based on MWFRS B Brg Wid = 3.5 Min Req = 1.5 (Truss) D Brg Wid = 1.5 Min Req = - C Brg Wid = 1.5 Min Req = - Bearing B is a rigid surface. Members not listed have forces less than 375#																																						

**Lumber**

Top chord: 2x4 SP #2;  
 Bot chord: 2x4 SP #2;

**Wind**

Wind loads based on MWFRS with additional C&C member design.  
 Wind loading based on both gable and hip roof types.

**Additional Notes**

The overall height of this truss excluding overhang is 0-10-3.

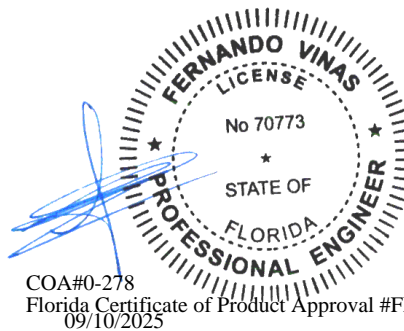

**\*\*WARNING\*\* READ AND FOLLOW ALL NOTES ON THIS DRAWING!**  
**\*\*IMPORTANT\*\* FURNISH THIS DRAWING TO ALL CONTRACTORS INCLUDING THE INSTALLERS**  
 Trusses require extreme care in fabricating, handling, shipping, installing and bracing. Refer to and follow the latest edition of BCSI (Building Component Safety Information, by TPI and SBCA) for safety practices prior to performing these functions. Installers shall provide temporary bracing per BCSI. Unless noted otherwise, top chord shall have properly attached structural sheathing and bottom chord shall have a properly attached rigid ceiling. Locations shown for permanent lateral restraint of webs shall have continuous lateral restraint (CLR), installed with diagonal bracing installed on the CLR per BCSI sections B3, B7, or B10, as applicable. Apply plates to each face of truss and position as shown above and on the Joint Details, unless noted otherwise. Refer to drawings 160A-Z for standard plate positions. Refer to job's General Notes page for additional information.  
 Alpine, a division of ITW Building Components Group Inc. shall not be responsible for any deviation from this drawing, any failure to build the truss in conformance with ANSI/TPI 1, or for handling, shipping, installation and bracing of trusses. A seal on this drawing or cover page listing this drawing, indicates acceptance of professional engineering responsibility solely for the design shown. The suitability and use of this drawing for any structure is the responsibility of the Building Designer per ANSI/TPI 1 Sec.2.  
 For more information see these web sites: Alpine: alpineitw.com; TPI: tpinst.org; SBCA: sbccomponents.com; ICC: iccsafe.org; AWC: awc.org

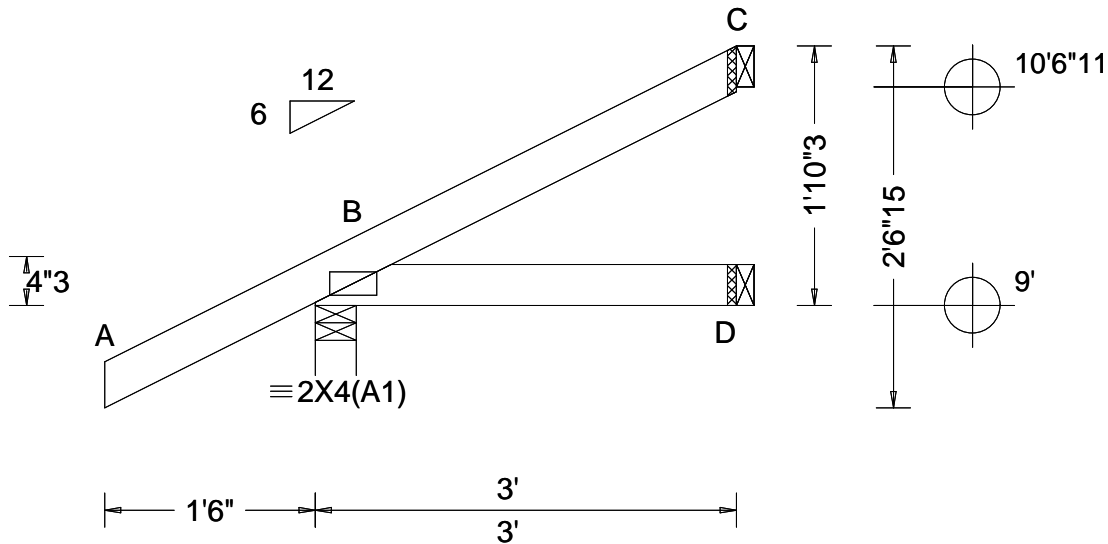

<b>Loading Criteria (psf)</b> TCCL: 20.00 TCCL: 10.00 BCLL: 0.00 BCDL: 10.00 Des Ld: 40.00 NCBCLL: 10.00 Soffit: 2.00 Load Duration: 1.25 Spacing: 24.0 "	<b>Wind Criteria</b> Wind Std: ASCE 7-22 Speed: 130 mph Enclosure: Closed Risk Category: II EXP: C Kzt: NA Mean Height: 15.00 ft TCCL: 4.2 psf BCDL: 3.0 psf MWFRS Parallel Dist: 0 to h/2 C&C Dist a: 3.00 ft Loc. from endwall: not in 4.50 ft GCpi: 0.18 Wind Duration: 1.60	<b>Snow Criteria (Pg,Pf in PSF)</b> Pg: NA Ct: NA CAT: NA Pf: NA Ce: NA Lu: NA Cs: NA Snow Duration: NA Building Code: FBC 8th Ed. 2023 Res. TPI Std: 2014 Rep Fac: Yes FT/RT:20(0)/10(0) Plate Type(s): WAVE	<b>Defl/CSI Criteria</b> PP Deflection in loc L/defl L/# VERT(LL): NA VERT(CL): NA HORZ(LL): 0.001 B - - HORZ(TL): 0.002 B - - Creep Factor: 2.0 Max TC CSI: 0.209 Max BC CSI: 0.064 Max Web CSI: 0.000 VIEW Ver: 24.02.00D.0114.10	<b>▲ Maximum Reactions (lbs)</b> <table border="1"> <thead> <tr> <th rowspan="2">Loc</th> <th colspan="3">Gravity</th> <th colspan="3">Non-Gravity</th> </tr> <tr> <th>R+</th> <th>/R-</th> <th>/Rh</th> <th>/Rw</th> <th>/U</th> <th>/RL</th> </tr> </thead> <tbody> <tr> <td>B</td> <td>262</td> <td>-</td> <td>-</td> <td>/100</td> <td>/55</td> <td>/74</td> </tr> <tr> <td>D</td> <td>49</td> <td>-</td> <td>-</td> <td>/32</td> <td>-</td> <td>-</td> </tr> <tr> <td>C</td> <td>62</td> <td>-</td> <td>-</td> <td>/51</td> <td>/37</td> <td>-</td> </tr> </tbody> </table> Wind reactions based on MWFRS B Brg Wid = 3.5 Min Req = 1.5 (Truss) D Brg Wid = 1.5 Min Req = - C Brg Wid = 1.5 Min Req = - Bearing B is a rigid surface. Members not listed have forces less than 375#	Loc	Gravity			Non-Gravity			R+	/R-	/Rh	/Rw	/U	/RL	B	262	-	-	/100	/55	/74	D	49	-	-	/32	-	-	C	62	-	-	/51	/37	-
				Loc		Gravity			Non-Gravity																													
R+	/R-	/Rh	/Rw		/U	/RL																																
B	262	-	-	/100	/55	/74																																
D	49	-	-	/32	-	-																																
C	62	-	-	/51	/37	-																																
<b>Lumber</b> Top chord: 2x4 SP #2; Bot chord: 2x4 SP #2; <b>Wind</b> Wind loads based on MWFRS with additional C&C member design. Wind loading based on both gable and hip roof types. <b>Additional Notes</b> The overall height of this truss excluding overhang is 1-10-3.																																						

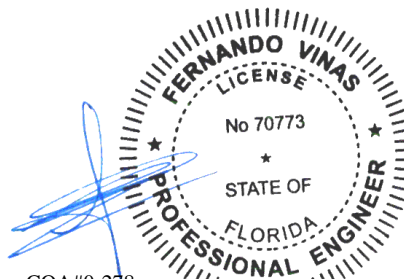

COA#0-278  
 Florida Certificate of Product Approval #FL1999  
 09/10/2025

**\*\*WARNING\*\* READ AND FOLLOW ALL NOTES ON THIS DRAWING!**  
**\*\*IMPORTANT\*\* FURNISH THIS DRAWING TO ALL CONTRACTORS INCLUDING THE INSTALLERS**  
 Trusses require extreme care in fabricating, handling, shipping, installing and bracing. Refer to and follow the latest edition of BCSI (Building Component Safety Information, by TPI and SBCA) for safety practices prior to performing these functions. Installers shall provide temporary bracing per BCSI. Unless noted otherwise, top chord shall have properly attached structural sheathing and bottom chord shall have a properly attached rigid ceiling. Locations shown for permanent lateral restraint of webs shall have continuous lateral restraint (CLR), installed with diagonal bracing installed on the CLR per BCSI sections B3, B7, or B10, as applicable. Apply plates to each face of truss and position as shown above and on the Joint Details, unless noted otherwise. Refer to drawings 160A-Z for standard plate positions. Refer to job's General Notes page for additional information.  
 Alpine, a division of ITW Building Components Group Inc. shall not be responsible for any deviation from this drawing, any failure to build the truss in conformance with ANSI/TPI 1, or for handling, shipping, installation and bracing of trusses. A seal on this drawing or cover page listing this drawing, indicates acceptance of professional engineering responsibility solely for the design shown. The suitability and use of this drawing for any structure is the responsibility of the Building Designer per ANSI/TPI 1 Sec.2.  
 For more information see these web sites: Alpine: alpineitw.com; TPI: tpinst.org; SBCA: sbccomponents.com; ICC: iccsafe.org; AWC: awc.org

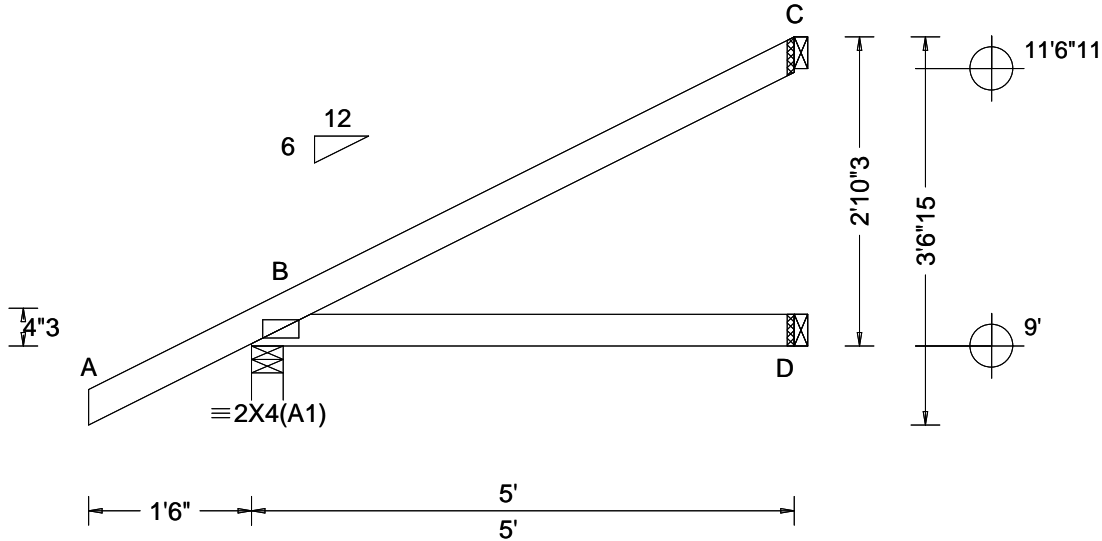

Loading Criteria (psf)	Wind Criteria	Snow Criteria (Pg,Pf in PSF)	Defl/CSI Criteria	▲ Maximum Reactions (lbs)						
				Gravity			Non-Gravity			
TCLL: 20.00	Wind Std: ASCE 7-22	Pg: NA Ct: NA CAT: NA	PP Deflection in loc L/defl L/#	Loc	R+	/R-	/Rh	/Rw	/U	/RL
TCDL: 10.00	Speed: 130 mph	Pf: NA Ce: NA	VERT(LL): NA	B	331	-	-	/140	/62	/109
BCLL: 0.00	Enclosure: Closed	Lu: NA Cs: NA	VERT(CL): NA	D	89	-	-	/55	-	-
BCDL: 10.00	Risk Category: II	Snow Duration: NA	HORZ(LL): 0.006 B - -	C	127	-	-	/88	/70	-
Des Ld: 40.00	EXP: C Kzt: NA		HORZ(TL): 0.011 B - -	Wind reactions based on MWFRS						
NCBCLL: 10.00	Mean Height: 15.00 ft	Building Code:	Creep Factor: 2.0	B Brg Wid = 3.5 Min Req = 1.5 (Truss)						
Soffit: 2.00	TCDL: 4.2 psf	FBC 8th Ed. 2023 Res.	Max TC CSI: 0.406	D Brg Wid = 1.5 Min Req = -						
Load Duration: 1.25	BCDL: 3.0 psf	TPI Std: 2014	Max BC CSI: 0.233	C Brg Wid = 1.5 Min Req = -						
Spacing: 24.0 "	MWFRS Parallel Dist: 0 to h/2	Rep Fac: Yes	Max Web CSI: 0.000	Bearing B is a rigid surface.						
	C&C Dist a: 3.00 ft	FT/RT:20(0)/10(0)	VIEW Ver: 24.02.00D.0114.10	Members not listed have forces less than 375#						
	Loc. from endwall: not in 4.50 ft	Plate Type(s):								
	GCp1: 0.18	WAVE								
	Wind Duration: 1.60									

#### Lumber

Top chord: 2x4 SP #2;  
Bot chord: 2x4 SP #2;

#### Wind

Wind loads based on MWFRS with additional C&C member design.

Wind loading based on both gable and hip roof types.

#### Additional Notes

The overall height of this truss excluding overhang is 2-10-3.

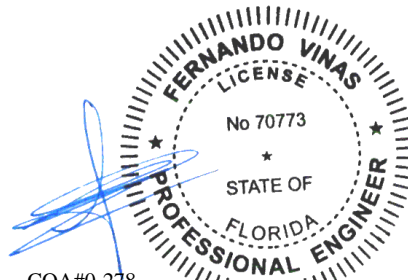

COA#0-278  
Florida Certificate of Product Approval #FL1999  
09/10/2025

**\*\*WARNING\*\* READ AND FOLLOW ALL NOTES ON THIS DRAWING!**  
**\*\*IMPORTANT\*\* FURNISH THIS DRAWING TO ALL CONTRACTORS INCLUDING THE INSTALLERS**  
Trusses require extreme care in fabricating, handling, shipping, installing and bracing. Refer to and follow the latest edition of BCSI (Building Component Safety Information, by TPI and SBCA) for safety practices prior to performing these functions. Installers shall provide temporary bracing per BCSI. Unless noted otherwise, top chord shall have properly attached structural sheathing and bottom chord shall have a properly attached rigid ceiling. Locations shown for permanent lateral restraint of webs shall have continuous lateral restraint (CLR), installed with diagonal bracing installed on the CLR per BCSI sections B3, B7, or B10, as applicable. Apply plates to each face of truss and position as shown above and on the Joint Details, unless noted otherwise. Refer to drawings 160A-Z for standard plate positions. Refer to job's General Notes page for additional information.  
Alpine, a division of ITW Building Components Group Inc. shall not be responsible for any deviation from this drawing, any failure to build the truss in conformance with ANSI/TPI 1, or for handling, shipping, installation and bracing of trusses. A seal on this drawing or cover page listing this drawing, indicates acceptance of professional engineering responsibility solely for the design shown. The suitability and use of this drawing for any structure is the responsibility of the Building Designer per ANSI/TPI 1 Sec.2.  
For more information see these web sites: Alpine: [alpineitw.com](http://alpineitw.com); TPI: [tpinst.org](http://tpinst.org); SBCA: [sbcacomponents.com](http://sbcacomponents.com); ICC: [iccsafe.org](http://iccsafe.org); AWC: [awc.org](http://awc.org)

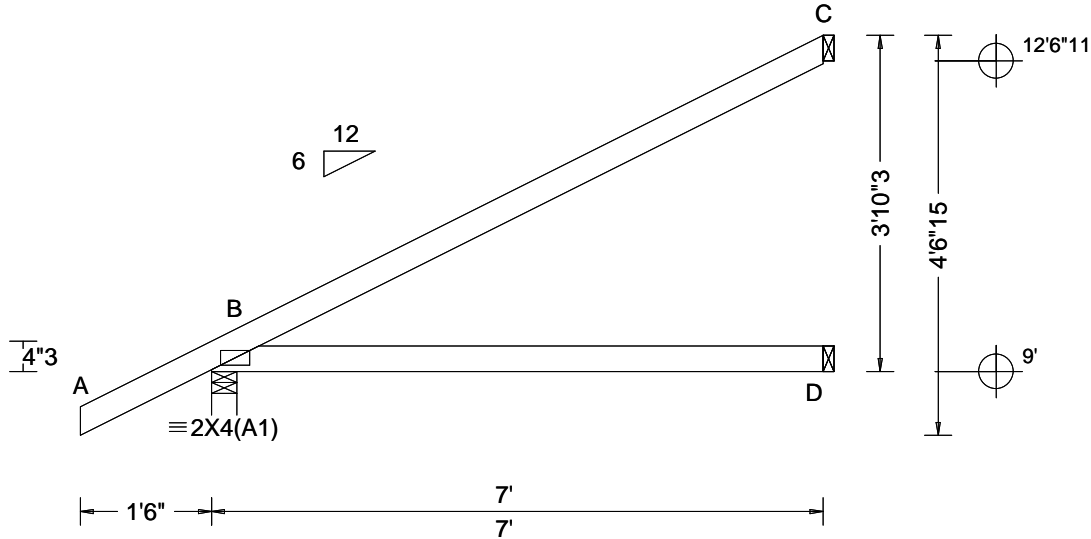

<b>Loading Criteria (psf)</b> TCCL: 20.00 TCDL: 10.00 BCLL: 0.00 BCDL: 10.00 Des Ld: 40.00 NCBCLL: 10.00 Soffit: 2.00 Load Duration: 1.25 Spacing: 24.0 "	<b>Wind Criteria</b> Wind Std: ASCE 7-22 Speed: 130 mph Enclosure: Closed Risk Category: II EXP: C Kzt: NA Mean Height: 15.00 ft TCDL: 4.2 psf BCDL: 3.0 psf MWFRS Parallel Dist: h/2 to h C&C Dist a: 3.00 ft Loc. from endwall: not in 4.50 ft GCp: 0.18 Wind Duration: 1.60	<b>Snow Criteria (Pg,Pf in PSF)</b> Pg: NA Ct: NA CAT: NA Pf: NA Ce: NA Lu: NA Cs: NA Snow Duration: NA Building Code: FBC 8th Ed. 2023 Res. TPI Std: 2014 Rep Fac: Yes FT/RT:20(0)/10(0) Plate Type(s): WAVE	<b>Defl/CSI Criteria</b> PP Deflection in loc L/defl L/# VERT(LL): NA VERT(CL): NA HORZ(LL): 0.022 B - - HORZ(TL): 0.028 B - - Creep Factor: 2.0 Max TC CSI: 0.713 Max BC CSI: 0.512 Max Web CSI: 0.000 VIEW Ver: 24.02.00D.0114.10	<b>▲ Maximum Reactions (lbs)</b> <table border="1"> <thead> <tr> <th rowspan="2">Loc</th> <th colspan="3">Gravity</th> <th colspan="3">Non-Gravity</th> </tr> <tr> <th>R+</th> <th>/R-</th> <th>/Rh</th> <th>/Rw</th> <th>/U</th> <th>/RL</th> </tr> </thead> <tbody> <tr> <td>B</td> <td>408</td> <td>-</td> <td>-</td> <td>/191</td> <td>/71</td> <td>/145</td> </tr> <tr> <td>D</td> <td>129</td> <td>-</td> <td>-</td> <td>/78</td> <td>-</td> <td>-</td> </tr> <tr> <td>C</td> <td>187</td> <td>-</td> <td>-</td> <td>/124</td> <td>/100</td> <td>-</td> </tr> </tbody> </table>	Loc	Gravity			Non-Gravity			R+	/R-	/Rh	/Rw	/U	/RL	B	408	-	-	/191	/71	/145	D	129	-	-	/78	-	-	C	187	-	-	/124	/100	-
				Loc		Gravity			Non-Gravity																													
R+	/R-	/Rh	/Rw		/U	/RL																																
B	408	-	-	/191	/71	/145																																
D	129	-	-	/78	-	-																																
C	187	-	-	/124	/100	-																																
Wind reactions based on MWFRS B Brg Wid = 3.5 Min Req = 1.5 (Truss) D Brg Wid = 1.5 Min Req = - C Brg Wid = 1.5 Min Req = - Bearing B is a rigid surface. Members not listed have forces less than 375#																																						

**Lumber**

Top chord: 2x4 SP #2;  
 Bot chord: 2x4 SP #2;

**Wind**

Wind loads based on MWFRS with additional C&C member design.  
 Wind loading based on both gable and hip roof types.

**Additional Notes**

The overall height of this truss excluding overhang is 3-10-3.

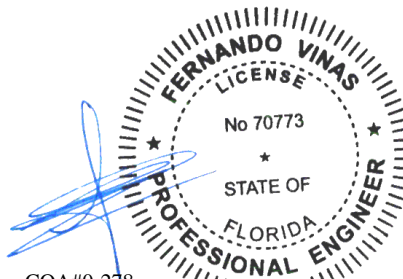

COA#0-278  
 Florida Certificate of Product Approval #FL1999  
 09/10/2025

**\*\*WARNING\*\* READ AND FOLLOW ALL NOTES ON THIS DRAWING!**  
**\*\*IMPORTANT\*\* FURNISH THIS DRAWING TO ALL CONTRACTORS INCLUDING THE INSTALLERS**  
 Trusses require extreme care in fabricating, handling, shipping, installing and bracing. Refer to and follow the latest edition of BCSI (Building Component Safety Information, by TPI and SBCA) for safety practices prior to performing these functions. Installers shall provide temporary bracing per BCSI. Unless noted otherwise, top chord shall have properly attached structural sheathing and bottom chord shall have a properly attached rigid ceiling. Locations shown for permanent lateral restraint of webs shall have continuous lateral restraint (CLR), installed with diagonal bracing installed on the CLR per BCSI sections B3, B7, or B10, as applicable. Apply plates to each face of truss and position as shown above and on the Joint Details, unless noted otherwise. Refer to drawings 160A-Z for standard plate positions. Refer to job's General Notes page for additional information.  
 Alpine, a division of ITW Building Components Group Inc. shall not be responsible for any deviation from this drawing, any failure to build the truss in conformance with ANSI/TPI 1, or for handling, shipping, installation and bracing of trusses. A seal on this drawing or cover page listing this drawing, indicates acceptance of professional engineering responsibility solely for the design shown. The suitability and use of this drawing for any structure is the responsibility of the Building Designer per ANSI/TPI 1 Sec.2.  
 For more information see these web sites: Alpine: alpineitw.com; TPI: tpinst.org; SBCA: sbccomponents.com; ICC: iccsafe.org; AWC: awc.org

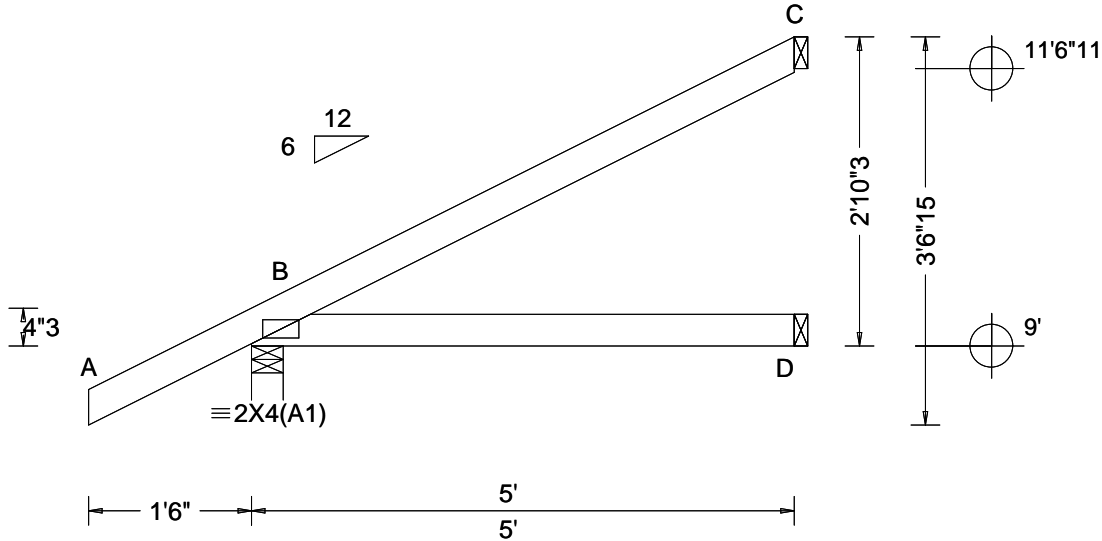

Loading Criteria (psf)	Wind Criteria	Snow Criteria (Pg,Pf in PSF)	Defl/CSI Criteria	▲ Maximum Reactions (lbs)						
				Gravity			Non-Gravity			
TCLL: 20.00	Wind Std: ASCE 7-22	Pg: NA Ct: NA CAT: NA	PP Deflection in loc L/defl L/#	Loc	R+	/R-	/Rh	/Rw	/U	/RL
TCDL: 10.00	Speed: 130 mph	Pf: NA Ce: NA	VERT(LL): NA	B	331	-	-	/140	/62	/109
BCLL: 0.00	Enclosure: Closed	Lu: NA Cs: NA	VERT(CL): NA	D	89	-	-	/55	-	-
BCDL: 10.00	Risk Category: II	Snow Duration: NA	HORZ(LL): 0.006 B - -	C	127	-	-	/88	/70	-
Des Ld: 40.00	EXP: C Kzt: NA		HORZ(TL): 0.008 B - -	Wind reactions based on MWFRS						
NCBCLL: 10.00	Mean Height: 15.00 ft	Building Code:	Creep Factor: 2.0	B Brg Wid = 3.5 Min Req = 1.5 (Truss)						
Soffit: 2.00	TCDL: 4.2 psf	FBC 8th Ed. 2023 Res.	Max TC CSI: 0.406	D Brg Wid = 1.5 Min Req = -						
Load Duration: 1.25	BCDL: 3.0 psf	TPI Std: 2014	Max BC CSI: 0.233	C Brg Wid = 1.5 Min Req = -						
Spacing: 24.0 "	MWFRS Parallel Dist: 0 to h/2	Rep Fac: Yes	Max Web CSI: 0.000	Bearing B is a rigid surface.						
	C&C Dist a: 3.00 ft	FT/RT:20(0)/10(0)	VIEW Ver: 24.02.00D.0114.10	Members not listed have forces less than 375#						
	Loc. from endwall: not in 4.50 ft	Plate Type(s):								
	GCp1: 0.18	WAVE								
	Wind Duration: 1.60									

**Lumber**

Top chord: 2x4 SP #2;  
Bot chord: 2x4 SP #2;

**Wind**

Wind loads based on MWFRS with additional C&C member design.  
Wind loading based on both gable and hip roof types.

**Additional Notes**

The overall height of this truss excluding overhang is 2-10-3.

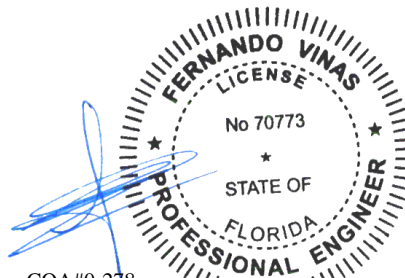

COA#0-278  
Florida Certificate of Product Approval #FL1999  
09/10/2025

**\*\*WARNING\*\* READ AND FOLLOW ALL NOTES ON THIS DRAWING!**  
**\*\*IMPORTANT\*\* FURNISH THIS DRAWING TO ALL CONTRACTORS INCLUDING THE INSTALLERS**  
Trusses require extreme care in fabricating, handling, shipping, installing and bracing. Refer to and follow the latest edition of BCSI (Building Component Safety Information, by TPI and SBCA) for safety practices prior to performing these functions. Installers shall provide temporary bracing per BCSI. Unless noted otherwise, top chord shall have properly attached structural sheathing and bottom chord shall have a properly attached rigid ceiling. Locations shown for permanent lateral restraint of webs shall have continuous lateral restraint (CLR), installed with diagonal bracing installed on the CLR per BCSI sections B3, B7, or B10, as applicable. Apply plates to each face of truss and position as shown above and on the Joint Details, unless noted otherwise. Refer to drawings 160A-Z for standard plate positions. Refer to job's General Notes page for additional information.  
Alpine, a division of ITW Building Components Group Inc. shall not be responsible for any deviation from this drawing, any failure to build the truss in conformance with ANSI/TPI 1, or for handling, shipping, installation and bracing of trusses. A seal on this drawing or cover page listing this drawing, indicates acceptance of professional engineering responsibility solely for the design shown. The suitability and use of this drawing for any structure is the responsibility of the Building Designer per ANSI/TPI 1 Sec.2.  
For more information see these web sites: Alpine: alpineitw.com; TPI: tpinst.org; SBCA: sbccomponents.com; ICC: iccsafe.org; AWC: awc.org

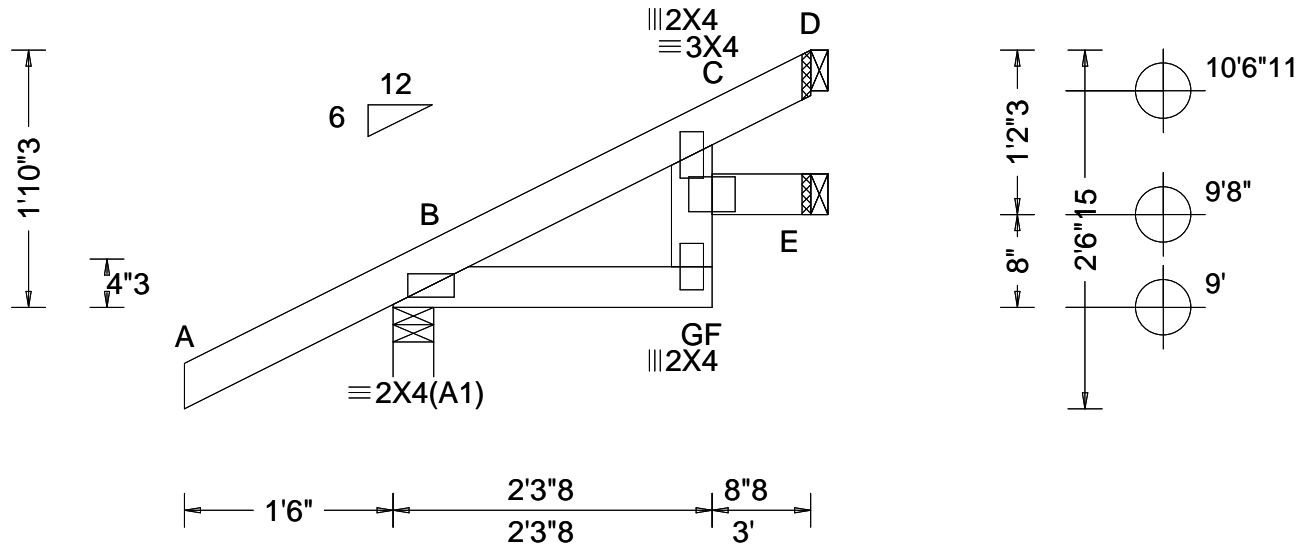

<b>Loading Criteria (psf)</b> TCCL: 20.00 TCCL: 10.00 BCLL: 0.00 BCDL: 10.00 Des Ld: 40.00 NCBCLL: 10.00 Soffit: 2.00 Load Duration: 1.25 Spacing: 24.0 "	<b>Wind Criteria</b> Wind Std: ASCE 7-22 Speed: 130 mph Enclosure: Closed Risk Category: II EXP: C Kzt: NA Mean Height: 15.00 ft TCCL: 4.2 psf BCDL: 3.0 psf MWFRS Parallel Dist: 0 to h/2 C&C Dist a: 3.00 ft Loc. from endwall: not in 4.50 ft GCp: 0.18 Wind Duration: 1.60	<b>Snow Criteria (Pg,Pf in PSF)</b> Pg: NA Ct: NA CAT: NA Pf: NA Ce: NA Lu: NA Cs: NA Snow Duration: NA Building Code: FBC 8th Ed. 2023 Res. TPI Std: 2014 Rep Fac: Yes FT/RT:20(0)/10(0) Plate Type(s): WAVE	<b>Defl/CSI Criteria</b> PP Deflection in loc L/defl L/# VERT(LL): 0.003 F 999 240 VERT(CL): 0.005 F 999 180 HORZ(LL): 0.001 C - - HORZ(TL): 0.003 C - - Creep Factor: 2.0 Max TC CSI: 0.209 Max BC CSI: 0.043 Max Web CSI: 0.029 VIEW Ver: 24.02.00D.0114.10	<b>▲ Maximum Reactions (lbs)</b> <table border="1"> <thead> <tr> <th rowspan="2">Loc</th> <th colspan="3">Gravity</th> <th colspan="3">Non-Gravity</th> </tr> <tr> <th>R+</th> <th>/R-</th> <th>/Rh</th> <th>/Rw</th> <th>/U</th> <th>/RL</th> </tr> </thead> <tbody> <tr> <td>B</td> <td>262</td> <td>-</td> <td>-</td> <td>/100</td> <td>/55</td> <td>/74</td> </tr> <tr> <td>E</td> <td>21</td> <td>-</td> <td>-</td> <td>/16</td> <td>/1</td> <td>-</td> </tr> <tr> <td>D</td> <td>72</td> <td>-</td> <td>-</td> <td>/67</td> <td>/31</td> <td>-</td> </tr> </tbody> </table>	Loc	Gravity			Non-Gravity			R+	/R-	/Rh	/Rw	/U	/RL	B	262	-	-	/100	/55	/74	E	21	-	-	/16	/1	-	D	72	-	-	/67	/31	-
				Loc		Gravity			Non-Gravity																													
R+	/R-	/Rh	/Rw		/U	/RL																																
B	262	-	-	/100	/55	/74																																
E	21	-	-	/16	/1	-																																
D	72	-	-	/67	/31	-																																
Wind reactions based on MWFRS B Brg Wid = 3.5 Min Req = 1.5 (Truss) E Brg Wid = 1.5 Min Req = - D Brg Wid = 1.5 Min Req = - Bearing B is a rigid surface. Members not listed have forces less than 375#																																						

**Lumber**

Top chord: 2x4 SP #2;  
 Bot chord: 2x4 SP #2;  
 Webs: 2x4 SP #3;

**Wind**

Wind loads based on MWFRS with additional C&C member design.  
 Wind loading based on both gable and hip roof types.

**Additional Notes**

The overall height of this truss excluding overhang is 1-10-3.

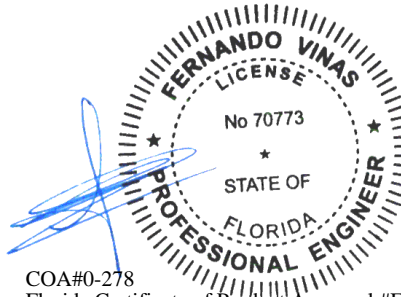

COA#0-278  
 Florida Certificate of Product Approval #FL1999  
 09/10/2025

**\*\*WARNING\*\* READ AND FOLLOW ALL NOTES ON THIS DRAWING!**  
**\*\*IMPORTANT\*\* FURNISH THIS DRAWING TO ALL CONTRACTORS INCLUDING THE INSTALLERS**  
 Trusses require extreme care in fabricating, handling, shipping, installing and bracing. Refer to and follow the latest edition of BCSI (Building Component Safety Information, by TPI and SBCA) for safety practices prior to performing these functions. Installers shall provide temporary bracing per BCSI. Unless noted otherwise, top chord shall have properly attached structural sheathing and bottom chord shall have a properly attached rigid ceiling. Locations shown for permanent lateral restraint of webs shall have continuous lateral restraint (CLR), installed with diagonal bracing installed on the CLR per BCSI sections B3, B7, or B10, as applicable. Apply plates to each face of truss and position as shown above and on the Joint Details, unless noted otherwise. Refer to drawings 160A-Z for standard plate positions. Refer to job's General Notes page for additional information.  
 Alpine, a division of ITW Building Components Group Inc. shall not be responsible for any deviation from this drawing, any failure to build the truss in conformance with ANSI/TPI 1, or for handling, shipping, installation and bracing of trusses. A seal on this drawing or cover page listing this drawing, indicates acceptance of professional engineering responsibility solely for the design shown. The suitability and use of this drawing for any structure is the responsibility of the Building Designer per ANSI/TPI 1 Sec.2.  
 For more information see these web sites: Alpine: alpineitw.com; TPI: tpinst.org; SBCA: sbccomponents.com; ICC: iccsafe.org; AWC: awc.org



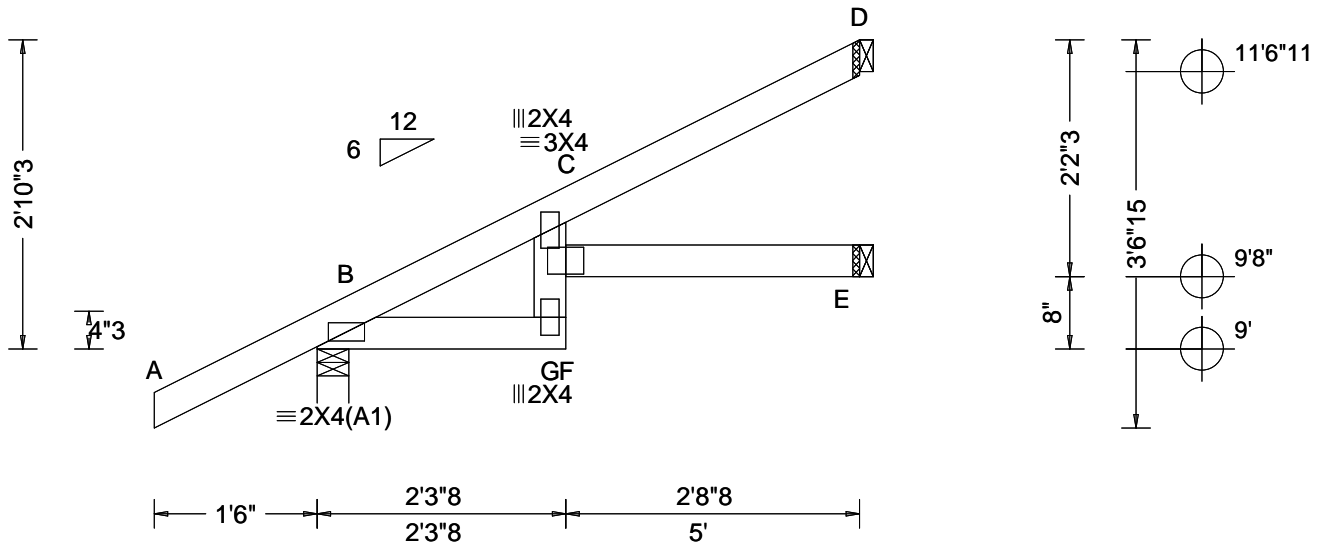

<b>Loading Criteria (psf)</b> TCCL: 20.00 TCCL: 10.00 BCLL: 0.00 BCDL: 10.00 Des Ld: 40.00 NCBCLL: 10.00 Soffit: 2.00 Load Duration: 1.25 Spacing: 24.0 "	<b>Wind Criteria</b> Wind Std: ASCE 7-22 Speed: 130 mph Enclosure: Closed Risk Category: II EXP: C Kzt: NA Mean Height: 15.00 ft TCCL: 4.2 psf BCDL: 3.0 psf MWFRS Parallel Dist: 0 to h/2 C&C Dist a: 3.00 ft Loc. from endwall: not in 4.50 ft GCp: 0.18 Wind Duration: 1.60	<b>Snow Criteria (Pg,Pf in PSF)</b> Pg: NA Ct: NA CAT: NA Pf: NA Ce: NA Lu: NA Cs: NA Snow Duration: NA Building Code: FBC 8th Ed. 2023 Res. TPI Std: 2014 Rep Fac: Yes FT/RT:20(0)/10(0) Plate Type(s): WAVE	<b>Defl/CSI Criteria</b> PP Deflection in loc L/defl L/# VERT(LL): 0.075 F 775 240 VERT(CL): 0.093 F 625 180 HORZ(LL): 0.040 C - - HORZ(TL): 0.053 C - - Creep Factor: 2.0 Max TC CSI: 0.436 Max BC CSI: 0.115 Max Web CSI: 0.102 VIEW Ver: 24.02.00D.0114.10	<b>▲ Maximum Reactions (lbs)</b> <table border="1"> <thead> <tr> <th rowspan="2">Loc</th> <th colspan="3">Gravity</th> <th colspan="3">Non-Gravity</th> </tr> <tr> <th>R+</th> <th>/R-</th> <th>/Rh</th> <th>/Rw</th> <th>/U</th> <th>/RL</th> </tr> </thead> <tbody> <tr> <td>B</td> <td>331</td> <td>-</td> <td>-</td> <td>/140</td> <td>/62</td> <td>/109</td> </tr> <tr> <td>E</td> <td>63</td> <td>-</td> <td>-</td> <td>/38</td> <td>-</td> <td>-</td> </tr> <tr> <td>D</td> <td>142</td> <td>-</td> <td>-</td> <td>/105</td> <td>/68</td> <td>-</td> </tr> </tbody> </table>	Loc	Gravity			Non-Gravity			R+	/R-	/Rh	/Rw	/U	/RL	B	331	-	-	/140	/62	/109	E	63	-	-	/38	-	-	D	142	-	-	/105	/68	-
				Loc		Gravity			Non-Gravity																													
R+	/R-	/Rh	/Rw		/U	/RL																																
B	331	-	-	/140	/62	/109																																
E	63	-	-	/38	-	-																																
D	142	-	-	/105	/68	-																																
Wind reactions based on MWFRS B Brg Wid = 3.5 Min Req = 1.5 (Truss) E Brg Wid = 1.5 Min Req = - D Brg Wid = 1.5 Min Req = - Bearing B is a rigid surface. Members not listed have forces less than 375#																																						

**Lumber**

Top chord: 2x4 SP #2;  
 Bot chord: 2x4 SP #2;  
 Webs: 2x4 SP #3;

**Wind**

Wind loads based on MWFRS with additional C&C member design.  
 Wind loading based on both gable and hip roof types.

**Additional Notes**

The overall height of this truss excluding overhang is 2-10-3.

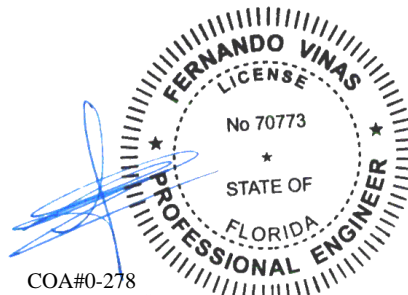

COA#0-278  
 Florida Certificate of Product Approval #FL1999  
 09/10/2025

**\*\*WARNING\*\* READ AND FOLLOW ALL NOTES ON THIS DRAWING!**  
**\*\*IMPORTANT\*\* FURNISH THIS DRAWING TO ALL CONTRACTORS INCLUDING THE INSTALLERS**  
 Trusses require extreme care in fabricating, handling, shipping, installing and bracing. Refer to and follow the latest edition of BCSI (Building Component Safety Information, by TPI and SBCA) for safety practices prior to performing these functions. Installers shall provide temporary bracing per BCSI. Unless noted otherwise, top chord shall have properly attached structural sheathing and bottom chord shall have a properly attached rigid ceiling. Locations shown for permanent lateral restraint of webs shall have continuous lateral restraint (CLR), installed with diagonal bracing installed on the CLR per BCSI sections B3, B7, or B10, as applicable. Apply plates to each face of truss and position as shown above and on the Joint Details, unless noted otherwise. Refer to drawings 160A-Z for standard plate positions. Refer to job's General Notes page for additional information.  
 Alpine, a division of ITW Building Components Group Inc. shall not be responsible for any deviation from this drawing, any failure to build the truss in conformance with ANSI/TPI 1, or for handling, shipping, installation and bracing of trusses. A seal on this drawing or cover page listing this drawing, indicates acceptance of professional engineering responsibility solely for the design shown. The suitability and use of this drawing for any structure is the responsibility of the Building Designer per ANSI/TPI 1 Sec.2.  
 For more information see these web sites: Alpine: alpineitw.com; TPI: tpinst.org; SBCA: sbcacomponents.com; ICC: iccsafe.org; AWC: awc.org



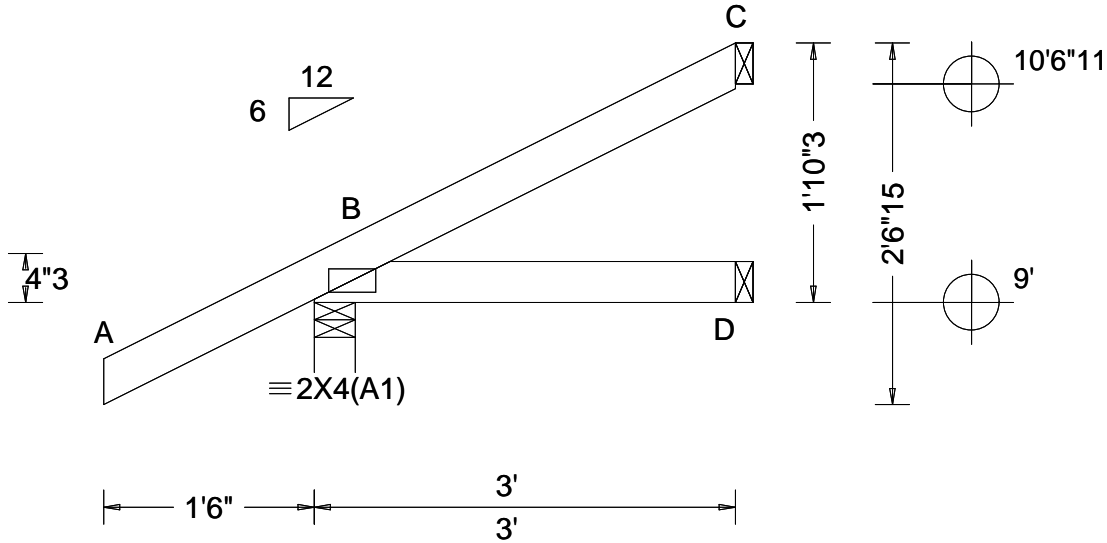

Loading Criteria (psf)	Wind Criteria	Snow Criteria (Pg,Pf in PSF)	Defl/CSI Criteria	▲ Maximum Reactions (lbs)						
				Gravity			Non-Gravity			
TCLL: 20.00	Wind Std: ASCE 7-22	Pg: NA Ct: NA CAT: NA	PP Deflection in loc L/defl L/#	Loc	R+	/R-	/Rh	/Rw	/U	/RL
TCDL: 10.00	Speed: 130 mph	Pf: NA Ce: NA	VERT(LL): NA	B	262	-	-	/100	/55	/74
BCLL: 0.00	Enclosure: Closed	Lu: NA Cs: NA	VERT(CL): NA	D	49	-	-	/32	-	-
BCDL: 10.00	Risk Category: II	Snow Duration: NA	HORZ(LL): 0.000 B - -	C	62	-	-	/51	/37	-
Des Ld: 40.00	EXP: C Kzt: NA		HORZ(TL): 0.001 B - -	Wind reactions based on MWFRS						
NCBCLL: 10.00	Mean Height: 15.00 ft	Building Code:	Creep Factor: 2.0	B Brg Wid = 3.5 Min Req = 1.5 (Truss)						
Soffit: 2.00	TCDL: 4.2 psf	FBC 8th Ed. 2023 Res.	Max TC CSI: 0.209	D Brg Wid = 1.5 Min Req = -						
Load Duration: 1.25	BCDL: 3.0 psf	TPI Std: 2014	Max BC CSI: 0.064	C Brg Wid = 1.5 Min Req = -						
Spacing: 24.0 "	MWFRS Parallel Dist: 0 to h/2	Rep Fac: Yes	Max Web CSI: 0.000	Bearing B is a rigid surface.						
	C&C Dist a: 3.00 ft	FT/RT:20(0)/10(0)	VIEW Ver: 24.02.00D.0114.10	Members not listed have forces less than 375#						
	Loc. from endwall: not in 4.50 ft	Plate Type(s):								
	GCpi: 0.18	WAVE								
	Wind Duration: 1.60									

**Lumber**

Top chord: 2x4 SP #2;  
Bot chord: 2x4 SP #2;

**Wind**

Wind loads based on MWFRS with additional C&C member design.  
Wind loading based on both gable and hip roof types.

**Additional Notes**

The overall height of this truss excluding overhang is 1-10-3.

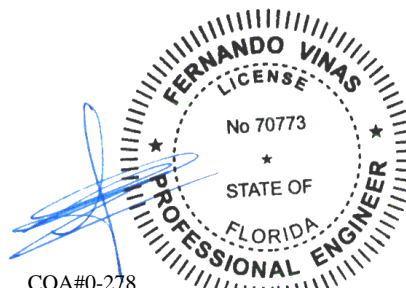

COA#0-278  
Florida Certificate of Product Approval #FL1999  
09/10/2025

**\*\*WARNING\*\* READ AND FOLLOW ALL NOTES ON THIS DRAWING!**  
**\*\*IMPORTANT\*\* FURNISH THIS DRAWING TO ALL CONTRACTORS INCLUDING THE INSTALLERS**  
Trusses require extreme care in fabricating, handling, shipping, installing and bracing. Refer to and follow the latest edition of BCSI (Building Component Safety Information, by TPI and SBCA) for safety practices prior to performing these functions. Installers shall provide temporary bracing per BCSI. Unless noted otherwise, top chord shall have properly attached structural sheathing and bottom chord shall have a properly attached rigid ceiling. Locations shown for permanent lateral restraint of webs shall have continuous lateral restraint (CLR), installed with diagonal bracing installed on the CLR per BCSI sections B3, B7, or B10, as applicable. Apply plates to each face of truss and position as shown above and on the Joint Details, unless noted otherwise. Refer to drawings 160A-Z for standard plate positions. Refer to job's General Notes page for additional information.  
Alpine, a division of ITW Building Components Group Inc. shall not be responsible for any deviation from this drawing, any failure to build the truss in conformance with ANSI/TPI 1, or for handling, shipping, installation and bracing of trusses. A seal on this drawing or cover page listing this drawing, indicates acceptance of professional engineering responsibility solely for the design shown. The suitability and use of this drawing for any structure is the responsibility of the Building Designer per ANSI/TPI 1 Sec.2.  
For more information see these web sites: Alpine: [alpineitw.com](http://alpineitw.com); TPI: [tpinst.org](http://tpinst.org); SBCA: [sbcacomponents.com](http://sbcacomponents.com); ICC: [iccsafe.org](http://iccsafe.org); AWC: [awc.org](http://awc.org)



155 Harlem Ave  
North Building, 4th Floor  
Glenview, IL 60025

# CLR Reinforcing Member Substitution

This detail is to be used when a Continuous Lateral Restraint (CLR) is specified on a truss design but an alternative web reinforcement method is desired.

## Notes:

This detail is only applicable for changing the specified CLR shown on single ply sealed designs to T-reinforcement or L-reinforcement or scab reinforcement.

Alternative reinforcement specified in chart below may be conservative. For minimum alternative reinforcement, re-run design with appropriate reinforcement type.

Use scabs instead of L- or T- reinforcement on webs with intersecting truss joints, such as K-web joints, that may interfere with proper application along the narrow face of the web.

Web Member Size	Specified CLR Restraint	Alternative Reinforcement T- or L- Reinf.	Scab Reinf.
2x3 or 2x4	1 row	2x4	1-2x4
2x3 or 2x4	2 rows	2x6 or 2x4	2-2x4
2x6	1 row	2x4	1-2x6
2x6	2 rows	2x6	2-2x4(*)
2x8	1 row	2x6	1-2x8
2x8	2 rows	2x6	2-2x6(*)

T-reinforcement, L-reinforcement, or scab reinforcement to be same species and grade or better than web member unless specified otherwise on Engineer's sealed design.

(\*) Center scab on wide face of web. Apply (1) scab to each face of web.

## T-Reinforcement or L-Reinforcement:

Apply to either side of web narrow face. Attach with 10d (0.128"x3.0",min) nails at 6" o.c. Reinforcing member is a minimum 80% of web member length.

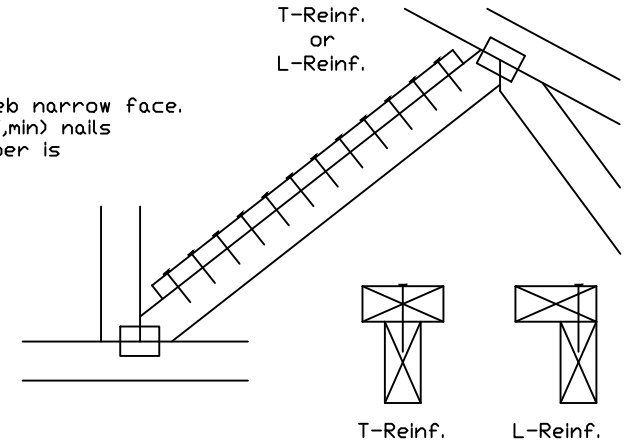

## Scab Reinforcement:

Apply scab(s) to wide face of web. No more than (1) scab per face. Attach with 10d (0.128"x3.0",min) nails at 6" o.c. Reinforcing member is a minimum 80% of web member length.

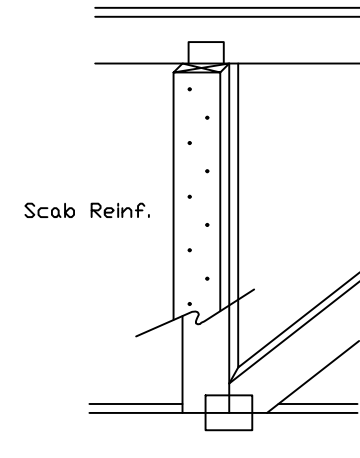

155 Harlem Ave  
North Building, 4th Floor  
Glenview, IL 60025

**WARNING: READ AND FOLLOW ALL NOTES ON THIS DRAWING**  
**IMPORTANT: FURNISH THIS DRAWING TO ALL CONTRACTORS INCLUDING THE INSTALLERS.**

Trusses require extreme care in fabricating, handling, shipping, installing and bracing. Refer to and follow the latest edition of BCSI (Building Component Safety Information, by TPI and SBCA) for safety practices prior to performing these functions. Installers shall provide temporary bracing per BCSI. Unless noted otherwise, top chord shall have properly attached structural sheathing and bottom chord shall have a properly attached rigid ceiling. Locations shown for permanent lateral restraint of webs shall have bracing installed per BCSI sections B3, B7 or B10, as applicable. Apply plates to each face of truss and position as shown above and on the Joint Details, unless noted otherwise. Refer to drawings 150A-Z for standard plate positions.

Alpine, a division of ITW Building Components Group Inc. shall not be responsible for any deviation from this drawing, any failure to build the truss in conformance with ANSI/TPI 1, or for handling, shipping, installation & bracing of trusses.

A seal on this drawing or cover page listing this drawing, indicates acceptance of professional engineering responsibility solely for the design shown. The suitability and use of this drawing for any structure is the responsibility of the Building Designer per ANSI/TPI 1 Sec.2.

For more information see this job's general notes page and these web sites:  
ALPINE: [www.alpineitw.com](http://www.alpineitw.com); TPI: [www.tpinst.org](http://www.tpinst.org); SBCA: [www.sbcacomponents.com](http://www.sbcacomponents.com); ICC: [www.iccsafe.org](http://www.iccsafe.org)

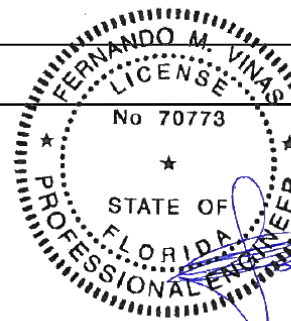

IC LL	PSF	REF	CLR Subst.
IC DL	PSF	DATE	01/02/19
IC DL	PSF	DRWG	BRCLBSUB0119
IC LL	PSF		
TOT. LD.	PSF		
001/0/2025			
SPACING			

COA#0-278  
Florida Certificate of Product Approval #FL1999