

# COLUMBIA COUNTY Property Appraiser

## Parcel 34-3S-17-06997-000

### Owners

JAMIESON JAMES  
JAMIESON SAMANTHA KATHLEEN  
401 SE TRIBBLE STREET  
LAKE CITY, FL 32025

### Parcel Summary

Location	401 SE TRIBBLE ST
Use Code	0100: SINGLE FAMILY
Tax District	2: COUNTY
Acreage	.2700
Section	34
Township	3S
Range	17
Subdivision	BELLAIRE
Exemptions	01: HOMESTEAD (196.031a&b) (100%)

### Legal Description

LOT 7 BLOCK C BELLAIRE S/D.

1007-1702,1704, LE 1009-936,  
DC 1041-2354, WD 1167-1145,  
WD 1192-1693, WD 1363-1220,

### Working Values

	2026
Total Building	\$110,755
Total Extra Features	\$1,010
Total Market Land	\$18,500
Total Ag Land	\$0



	2026
Total Market	\$130,265
Total Assessed	\$109,968
Total Exempt	\$51,411
Total Taxable	\$58,557
SOH Diff	\$20,297

## Value History

	2025	2024	2023	2022	2021	2020
Total Building	\$110,755	\$103,832	\$94,931	\$82,075	\$68,643	\$62,758
Total Extra Features	\$1,010	\$1,010	\$1,010	\$1,010	\$1,010	\$1,010
Total Market Land	\$18,500	\$18,500	\$18,500	\$15,000	\$10,800	\$10,720
Total Ag Land	\$0	\$0	\$0	\$0	\$0	\$0
Total Market	\$130,265	\$123,342	\$114,441	\$98,085	\$80,453	\$74,488
Total Assessed	\$107,077	\$104,059	\$101,028	\$98,085	\$80,453	\$74,488
Total Exempt	\$50,722	\$50,000	\$50,000	\$50,000	\$0	\$0
Total Taxable	\$56,355	\$54,059	\$51,028	\$48,085	\$80,453	\$74,488
SOH Diff	\$23,188	\$19,283	\$13,413	\$0	\$0	\$0

## Document/Transfer/Sales History

Instrument / Official Record	Date	Q/U	Reason	Type	V/I	Sale Price	Ownership
<u>WD</u> 1363/1220	2018-06-28	<u>Q</u>	<u>01</u>	WARRANTY DEED	Improved	\$96,000	Grantor: VICKIE LYNN STOCK Grantee: JAMES & SAMANTHA KATHLEEN JAMIESON (H/W)
<u>WD</u> 1192/1693	2010-04-12	<u>Q</u>	<u>01</u>	WARRANTY DEED	Improved	\$86,000	Grantor: KAY & ROBERT PRIEST & ETAL Grantee: VICKIE LYNN STOCK
<u>WD</u> 1167/1145	2009-02-11	<u>U</u>	<u>16</u>	WARRANTY DEED	Improved	\$43,500	Grantor: PATRICIA & WALTER GAYLORD Grantee: KAY & ROBERT PRIEST & ETAL JTWRs
<u>WD</u> 1009/0936	2004-03-08	<u>Q</u>	<u>01</u>	WARRANTY DEED	Improved	\$100	Grantor: HELEN WATERS Grantee: PATRICIA ,WALTER & JEROD GAYLORD (1/3 INT EA)
<u>WD</u> 1007/1704	2004-02-19	<u>Q</u>	<u>03</u>	WARRANTY DEED	Improved	\$100	Grantor: PATRICIA, WALTER & JEROD GAYLORD Grantee: PATRICIA & WALTER GAYLORD
<u>WD</u> 1007/1702	2004-02-12	<u>Q</u>	<u>01</u>	WARRANTY DEED	Improved	\$100	Grantor: HELEN WATERS Grantee: PATRICIA ,WALTER & JEROD GAYLOR (1/3 INT EA)

# Buildings

## Building # 1, Section # 1, 62758, SFR

Type	Models	Heated Sq Ft	Repl Cost New	YrBlt	Year Eff	Gross Area	Other % Dpr	Normal % Dpr	% Cond	Value
0100	01	920	\$170,392	1964	1985	1,530	0.00%	35.00%	65.00%	\$110,755

### Structural Elements

Type	Description	Code	Details
EW	Exterior Wall	15	CONC BLOCK
RS	Roof Structure	08	IRREGULAR
RC	Roof Cover	12	MODULAR MT
IW	Interior Wall	05	DRYWALL
IF	Interior Flooring	14	CARPET
IF	Interior Flooring	08	SHT VINYL
AC	Air Conditioning	03	CENTRAL
HT	Heating Type	04	AIR DUCTED
BDR	Bedrooms	3.00	
BTH	Bathrooms	1.50	
FR	Frame	01	NONE
STR	Stories	1.	1.
AR	Architectual Type	05	CONV
COND	Condition Adjustment	03	03
KTCH	Kitchen Adjustment	01	01

### Sub Areas

Type	Gross Area	Percent of Base	Adjusted Area
BAS	920	100%	920
FCP	236	25%	59
FST	121	55%	67
UEP	253	60%	152

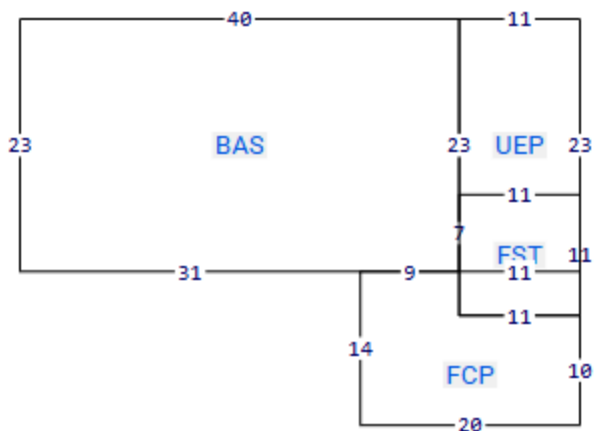

## Extra Features

Code	Description	Length	Width	Units	Unit Price	AYB	% Good Condition	Final Value
0166	CONC,PAVMT			1.00	\$0.00	0	100%	\$60
0294	SHED WOOD/VINYL			1.00	\$0.00	0	100%	\$550
0166	CONC,PAVMT			1.00	\$0.00	2012	100%	\$400

## Land Lines

Code	Description	Zone	Front	Depth	Units	Rate/Unit	Acreage	Total Adj	Value
0100	SFR	RSF-2	.00	.00	1.00	\$18,500.00/LT	0.27	1.00	\$18,500

## Personal Property

None

## Permits

None

## TRIM Notices

2025

2024

2023

## Disclaimer

All parcel data on this page is for use by the Columbia County Assessor for assessment purposes only. The summary data on this page may not be a complete representation of the parcel or of the improvements thereon. Building information, including unit counts and number of permitted units, should be verified with the appropriate building and planning agencies. Zoning information should be verified with the appropriate planning agency. All parcels are reappraised each year. This is a true and accurate copy of the records of the Columbia County Assessor's Office as of March 18, 2026.