



Lumber design values are in accordance with ANSI/TPI 1 section 6.3
 These truss designs rely on lumber values established by others.

73

RE: 2718981 - DETAILS

MiTek USA, Inc.

6904 Parke East Blvd.
 Tampa, FL 33610-4115

Site Information:

Customer Info: DETAILS Project Name: N/A Model: N/A
 Lot/Block: N/A Subdivision: N/A
 Address: N/A, N/A
 City: N/A State: N/A

Name Address and License # of Structural Engineer of Record, If there is one, for the building.

Name: License #:
 Address:
 City: State:

General Truss Engineering Criteria & Design Loads (Individual Truss Design Drawings Show Special Loading Conditions):

Design Code: FBC2020/TPI2014 Design Program: MiTek 20/20 8.4
 Wind Code: ASCE 7-16 Wind Speed: 130 mph
 Roof Load: 37.0 psf Floor Load: N/A psf

This package includes 20 individual, General Truss Details and 0 Additional Drawings.
 With my seal affixed to this sheet, I hereby certify that I am the Truss Design Engineer and this index sheet conforms to 61G15-31.003, section 5 of the Florida Board of Professional Engineers Rules.

No.	Seal#	Detail Name	Date	No.	Seal#	Detail Name	Date
1	T23399806	MII-REP10	4/2/21	15	T23399820	MII-VALLEY HIGH WIND2	4/2/21
2	T23399807	MII-T-BRACE 2	4/2/21	16	T23399821	MII-VALLEY SP	4/2/21
3	T23399808	MII-SCAB-BRACE	4/2/21	17	T23399822	MII-VALLEY SP	4/2/21
4	T23399809	MII-REP05	4/2/21	18	T23399823	MII-GE146-001	4/2/21
5	T23399810	MII-GE130-D-SP	4/2/21	19	T23399824	MII-REP13B	4/2/21
6	T23399811	MII-GE130-SP	4/2/21	20	T23399825	MII-STRGBCK	4/2/21
7	T23399812	MII-GE140-001	4/2/21				
8	T23399813	MII-GE170-D-SP	4/2/21				
9	T23399814	MII-GE180-D-SP	4/2/21				
10	T23399815	MII-GE180-D-SP	4/2/21				
11	T23399816	MII-PIGGY-ALT-7-16	4/2/21				
12	T23399817	MII-REP01A1	4/2/21				
13	T23399818	MII-TOENAIL SP	4/2/21				
14	T23399819	MII-VALLEY HIGH WIND1	4/2/21				

This item has been electronically signed and sealed by ORegan, Philip, PE using a Digital Signature.
 Printed copies of this document are not considered signed and sealed and the signature must be verified on any electronic copies.

The truss drawing(s) referenced above have been prepared by
 MiTek USA, Inc. under my direct supervision based on the parameters
 provided by Builders FirstSource-Jacksonville.

Truss Design Engineer's Name: ORegan, Philip
 My license renewal date for the state of Florida is February 28, 2023.

IMPORTANT NOTE: The seal on these truss component designs is a certification that the engineer named is licensed in the jurisdiction(s) identified and that the designs comply with ANSI/TPI 1. These designs are based upon parameters shown (e.g., loads, supports, dimensions, shapes and design codes), which were given to MiTek or TRENCO. Any project specific information included is for MiTek's or TRENCO's customers file reference purpose only, and was not taken into account in the preparation of these designs. MiTek or TRENCO has not independently verified the applicability of the design parameters or the designs for any particular building. Before use, the building designer should verify applicability of design parameters and properly incorporate these designs into the overall building design per ANSI/TPI 1, Chapter 2.

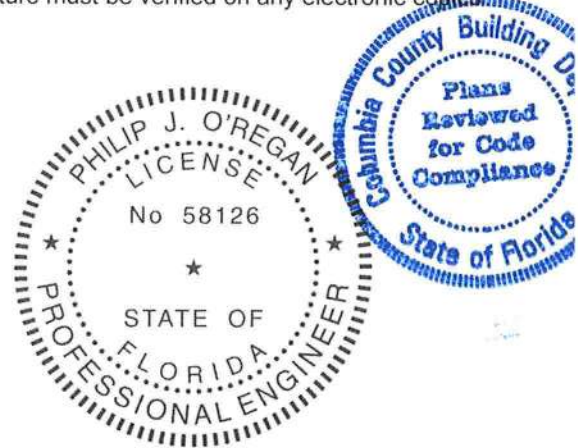

Philip J. O'Regan PE No.58126
 MiTek USA, Inc. FL Cert 6634
 6904 Parke East Blvd. Tampa FL 33610
 Date:

April 2,2021

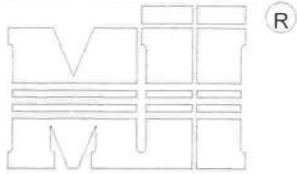

MiTek USA, Inc.

MAIN TRUSS MANUFACTURED WITHOUT
FALSE BOTTOM CHORD.

MAIN TRUSS (SPACING = 24" O.C.)

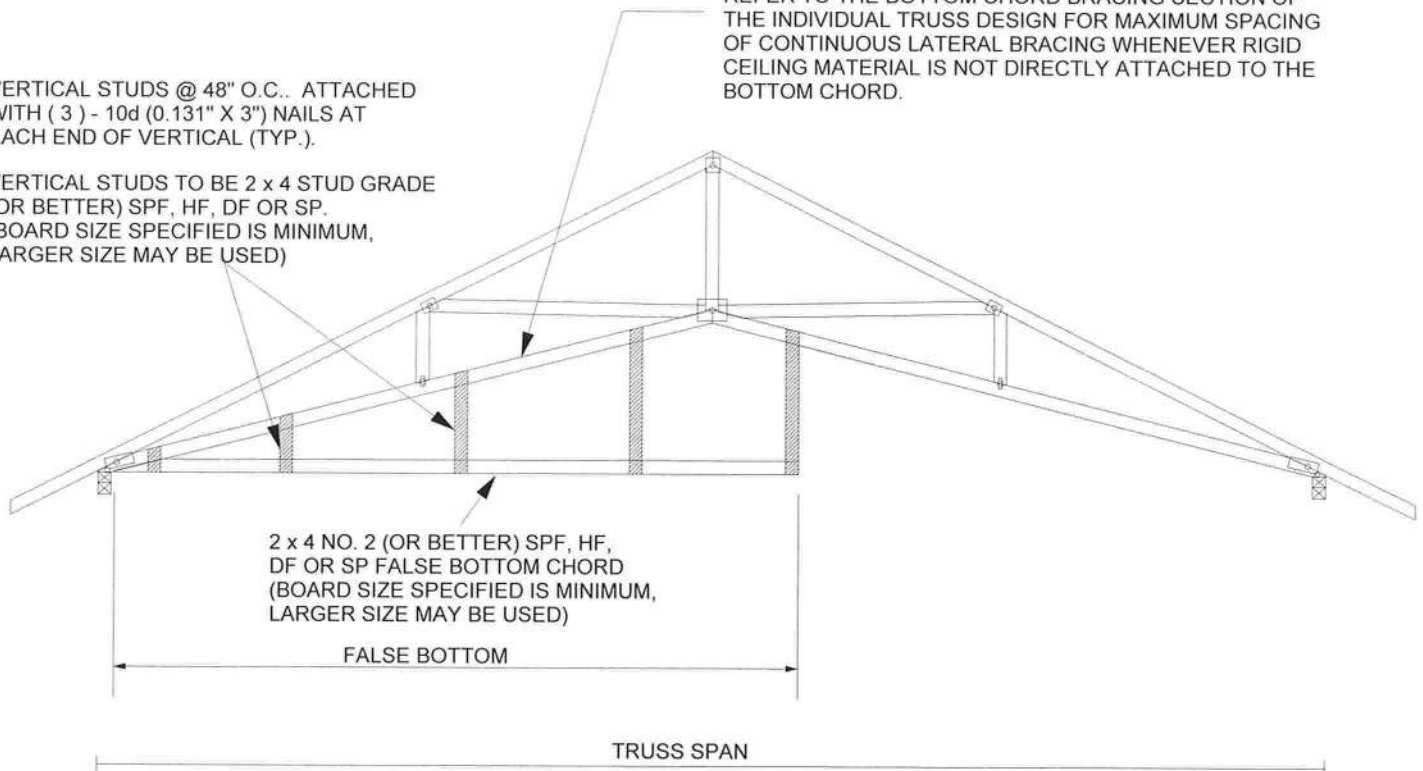
REFER TO THE BOTTOM CHORD BRACING SECTION OF
THE INDIVIDUAL TRUSS DESIGN FOR MAXIMUM SPACING OF
CONTINUOUS LATERAL BRACING WHENEVER RIGID
CEILING MATERIAL IS NOT DIRECTLY ATTACHED TO THE
BOTTOM CHORD.VERTICAL STUDS @ 48" O.C.. ATTACHED
WITH (3) - 10d (0.131" X 3") NAILS AT
EACH END OF VERTICAL (TYP.).VERTICAL STUDS TO BE 2 x 4 STUD GRADE
(OR BETTER) SPF, HF, DF OR SP.
(BOARD SIZE SPECIFIED IS MINIMUM,
LARGER SIZE MAY BE USED)2 x 4 NO. 2 (OR BETTER) SPF, HF,
DF OR SP FALSE BOTTOM CHORD
(BOARD SIZE SPECIFIED IS MINIMUM,
LARGER SIZE MAY BE USED)

FALSE BOTTOM

TRUSS SPAN

NOTES:

1. LOADING: TOP CHORD: (REFER TO THE MAIN TRUSS DESIGN FOR TOP CHORD LOADING).
BOTTOM CHORD: LL = 0 PSF, DL = 10 PSF.
2. REFER TO THE MAIN TRUSS DESIGN FOR LUMBER AND PLATING REQUIREMENTS.
3. MAXIMUM BOTTOM CHORD PITCH = 6/12.
4. THE END DISTANCE, EDGE DISTANCE, AND SPACING OF NAILS SHALL BE SUCH AS TO AVOID SPLITTING OF THE WOOD.
5. FALSE BOTTOM CHORD ONLY DESIGNED TO CARRY VERTICAL LOAD. NO LATERAL (SHEAR) LOAD ALLOWED.
6. FILLER MAY EXTEND FOR FULL LENGTH OF TRUSS.

This item has been electronically signed and sealed by O'Regan, Philip, P using a Digital Signature. Printed copies of this document are not considered signed and sealed and the signature must be verified on any electronic copies.

Philip J. O'Regan PE No.58126
MiTek USA, Inc. FL Cert 6634
6904 Parke East Blvd. Tampa FL 33610
Date:

April 2, 2022

WARNING - Verify design parameters and READ NOTES ON THIS AND INCLUDED MITEK REFERENCE PAGE MII-7473 rev. 5/19/2020 BEFORE USE.

Design valid for use only with MiTek® connectors. This design is based only upon parameters shown, and is for an individual building component, not a truss system. Before use, the building designer must verify the applicability of design parameters and properly incorporate this design into the overall building design. Bracing indicated is to prevent buckling of individual truss web and/or chord members only. Additional temporary and permanent bracing is always required for stability and to prevent collapse with possible personal injury and property damage. For general guidance regarding the fabrication, storage, delivery, erection and bracing of trusses and truss systems, see **ANSI/TPI1 Quality Criteria, DSB-89 and BCSI Building Component Safety Information** available from Truss Plate Institute, 2670 Crain Highway, Suite 203 Waldorf, MD 20601



6904 Parke East Blvd.
Tampa, FL 33610

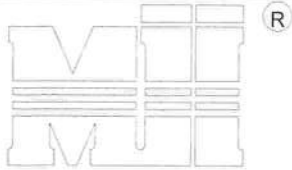

MiTek USA, Inc.

Note: T-Bracing / I-Bracing to be used when continuous lateral bracing is impractical. T-Brace / I-Brace must cover 90% of web length.

Note: This detail NOT to be used to convert T-Brace / I-Brace webs to continuous lateral braced webs.

Nailing Pattern		
T-Brace size	Nail Size	Nail Spacing
2x4 or 2x6 or 2x8	10d (0.131" X 3")	6" o.c.
Note: Nail along entire length of T-Brace / I-Brace (On Two-Ply's Nail to Both Plies)		

Web Size	Brace Size for One-Ply Truss	
	Specified Continuous Rows of Lateral Bracing	
	1	2
2x3 or 2x4	2x4 T-Brace	2x4 I-Brace
2x6	2x6 T-Brace	2x6 I-Brace
2x8	2x8 T-Brace	2x8 I-Brace

Web Size	Brace Size for Two-Ply Truss	
	Specified Continuous Rows of Lateral Bracing	
	1	2
2x3 or 2x4	2x4 T-Brace	2x4 I-Brace
2x6	2x6 T-Brace	2x6 I-Brace
2x8	2x8 T-Brace	2x8 I-Brace

T-Brace / I-Brace must be same species and grade (or better) as web member.

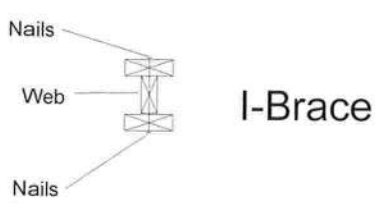
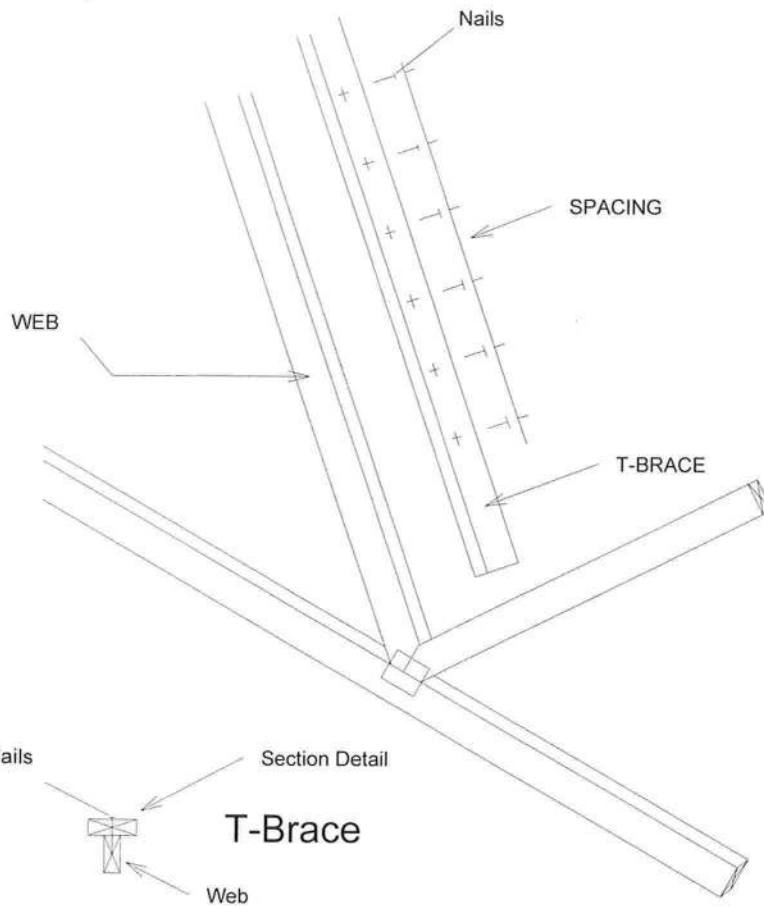

This item has been electronically signed and sealed by O'Regan, Philip, P using a Digital Signature. Printed copies of this document are not considered signed and sealed and the signature must be verified on any electronic copies.

Philip J. O'Regan PE No.58126
MiTek USA, Inc. FL Cert 6634
6904 Parke East Blvd. Tampa FL 33610
Date:

April 2, 202

WARNING - Verify design parameters and READ NOTES ON THIS AND INCLUDED MITEK REFERENCE PAGE MII-7473 rev. 5/19/2020 BEFORE USE.

Design valid for use only with MiTek® connectors. This design is based only upon parameters shown, and is for an individual building component, not a truss system. Before use, the building designer must verify the applicability of design parameters and properly incorporate this design into the overall building design. Bracing indicated is to prevent buckling of individual truss web and/or chord members only. Additional temporary and permanent bracing is always required for stability and to prevent collapse with possible personal injury and property damage. For general guidance regarding the fabrication, storage, delivery, erection and bracing of trusses and truss systems, see **ANSI/TPI1 Quality Criteria, DSB-89 and BCSI Building Component Safety Information** available from Truss Plate Institute, 2670 Crain Highway, Suite 203 Waldorf, MD 20601



6904 Parke East Blvd.
Tampa, FL 33610

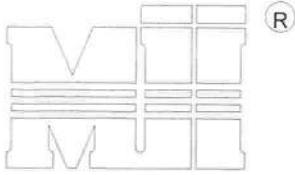

MiTek USA, Inc.

Note: Scab-Bracing to be used when continuous lateral bracing at midpoint (or T-Brace) is impractical.
Scab must cover full length of web +/- 6".

*** THIS DETAIL IS NOT APPLICABLE WHEN BRACING IS REQUIRED AT 1/3 POINTS OR I-BRACE IS SPECIFIED. ***

APPLY 2x SCAB TO ONE FACE OF WEB WITH 2 ROWS OF 10d (0.131" X 3") NAILS SPACED 6" O.C. SCAB MUST BE THE SAME GRADE, SIZE AND SPECIES (OR BETTER) AS THE WEB.

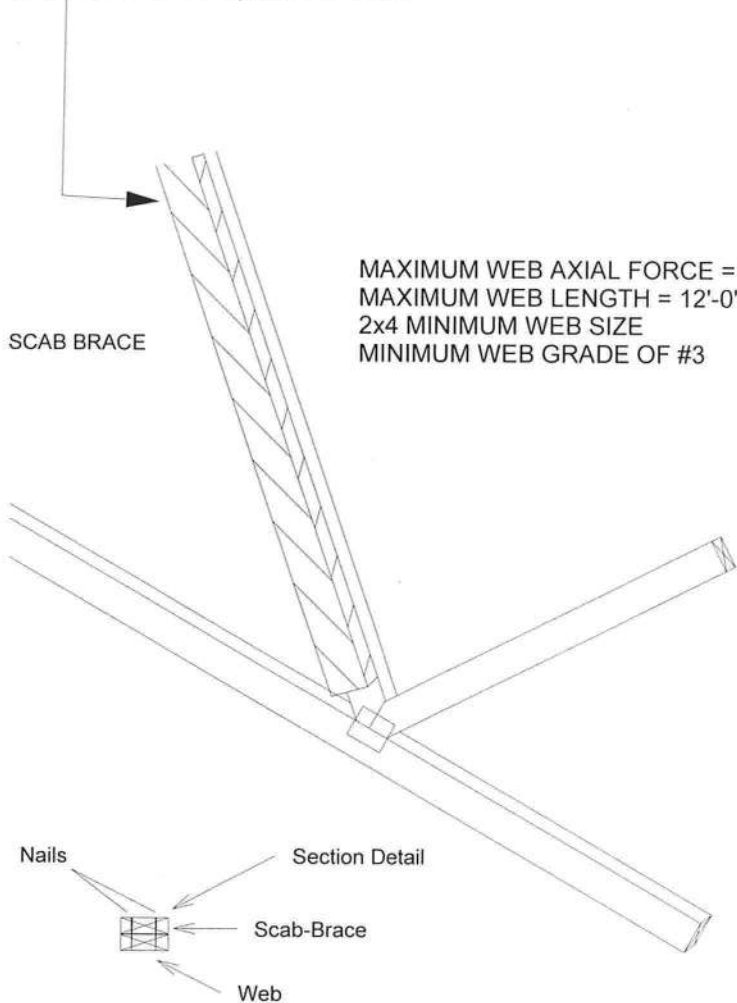

Scab-Brace must be same species grade (or better) as web member.

This item has been electronically signed and sealed by O'Regan, Philip, PI using a Digital Signature. Printed copies of this document are not considered signed and sealed and the signature must be verified on any electronic copies.

Philip J. O'Regan PE No.58126
MiTek USA, Inc. FL Cert 6634
6904 Parke East Blvd. Tampa FL 33610
Date:

April 2, 202

WARNING - Verify design parameters and READ NOTES ON THIS AND INCLUDED MITEK REFERENCE PAGE MII-7473 rev 5/19/2020 BEFORE USE.
Design valid for use only with MiTek® connectors. This design is based only upon parameters shown, and is for an individual building component, not a truss system. Before use, the building designer must verify the applicability of design parameters and properly incorporate this design into the overall building design. Bracing indicated is to prevent buckling of individual truss web and/or chord members only. Additional temporary and permanent bracing is always required for stability and to prevent collapse with possible personal injury and property damage. For general guidance regarding the fabrication, storage, delivery, erection and bracing of trusses and truss systems, see **ANSI/TPI1 Quality Criteria, DSB-89 and BCSI Building Component Safety Information** available from Truss Plate Institute, 2670 Crain Highway, Suite 203 Waldorf, MD 20601



6904 Parke East Blvd.
Tampa, FL 36610

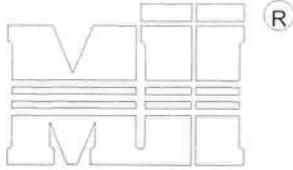

MiTek USA, Inc.

1. THIS IS A SPECIFIC REPAIR DETAIL TO BE USED ONLY FOR ITS ORIGINAL INTENTION. THIS REPAIR DOES NOT IMPLY THAT THE REMAINING PORTION OF THE TRUSS IS UNDAMAGED. THE ENTIRE TRUSS SHALL BE INSPECTED TO VERIFY THAT NO FURTHER REPAIRS ARE REQUIRED. WHEN THE REQUIRED REPAIRS ARE PROPERLY APPLIED, THE TRUSS WILL BE CAPABLE OF SUPPORTING THE LOADS INDICATED.
2. ALL MEMBERS MUST BE RETURNED TO THEIR ORIGINAL POSITIONS BEFORE APPLYING REPAIR AND HELD IN PLACE DURING APPLICATION OF REPAIR.
3. THE END DISTANCE, EDGE DISTANCE, AND SPACING OF NAILS SHALL BE SUCH AS TO AVOID SPLITTING OF THE WOOD.
4. LUMBER MUST BE CUT CLEANLY AND ACCURATELY AND THE REMAINING WOOD MUST BE UNDAMAGED.
5. THIS REPAIR IS TO BE USED FOR SINGLE PLY TRUSSES IN THE 4X ORIENTATION ONLY.
6. CONNECTOR PLATES MUST BE FULLY IMBEDDED AND UNDISTURBED.

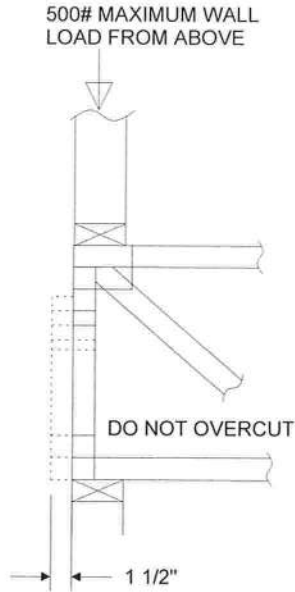

REFER TO INDIVIDUAL TRUSS DESIGN FOR PLATE SIZES AND LUMBER GRADES

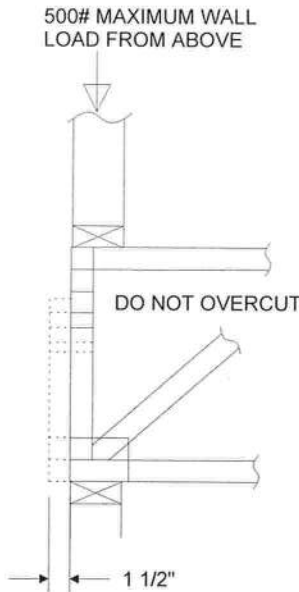

TRUSSES BUILT WITH 4x2 MEMBERS

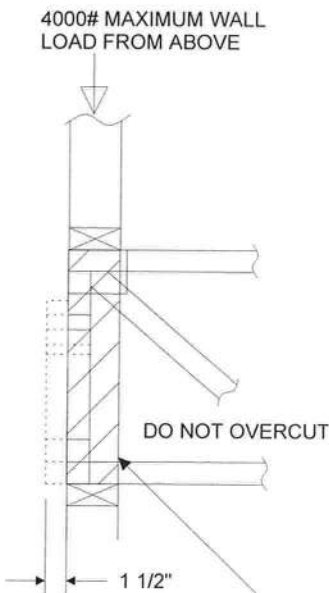

REFER TO INDIVIDUAL TRUSS DESIGN FOR PLATE SIZES AND LUMBER GRADES



TRUSSES BUILT WITH 4x2 MEMBERS

ATTACH 2x4 SQUASH BLOCK (CUT TO FIT TIGHTLY) TO BOTH SIDES OF THE TRUSS AS SHOWN WITH 10d (0.131" X 3") NAILS SPACED 3" O.C.

This item has been electronically signed and sealed by O'Regan, Philip, PE using a Digital Signature. Printed copies of this document are not considered signed and sealed and the signature must be verified on any electronic copies.

Philip J. O'Regan PE No.58126
MiTek USA, Inc. FL Cert 6634
6904 Parke East Blvd. Tampa FL 33610
Date:

April 2, 2022

WARNING - Verify design parameters and READ NOTES ON THIS AND INCLUDED MITEK REFERENCE PAGE MII-7473 rev 5/19/2020 BEFORE USE.

Design valid for use only with MiTek® connectors. This design is based only upon parameters shown, and is for an individual building component, not a truss system. Before use, the building designer must verify the applicability of design parameters and properly incorporate this design into the overall building design. Bracing indicated is to prevent buckling of individual truss web and/or chord members only. Additional temporary and permanent bracing is always required for stability and to prevent collapse with possible personal injury and property damage. For general guidance regarding the fabrication, storage, delivery, erection and bracing of trusses and truss systems, see ANSITP11 Quality Criteria, DSB-89 and BCSI Building Component Safety Information available from Truss Plate Institute, 2670 Crain Highway, Suite 203 Waldorf, MD 20601



6904 Parke East Blvd.
Tampa, FL 36610

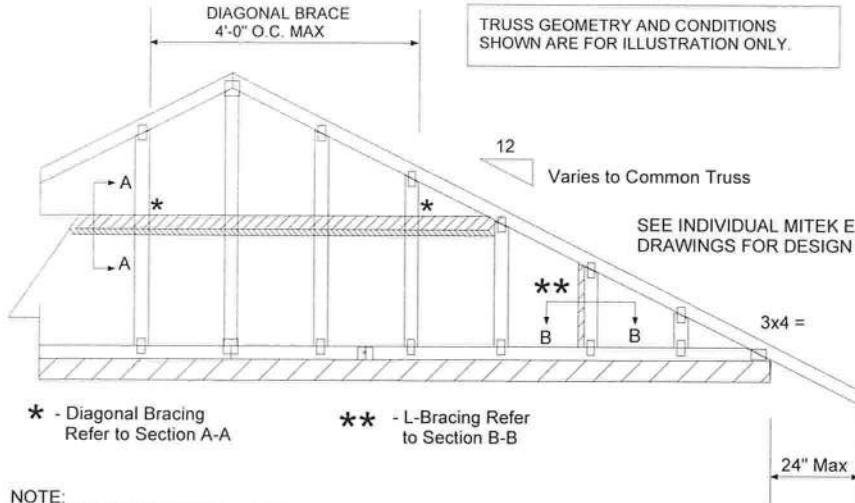
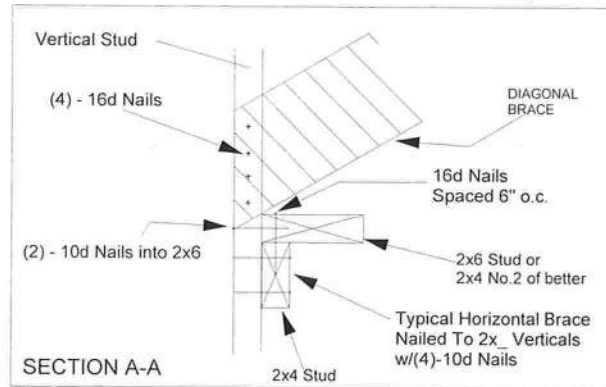
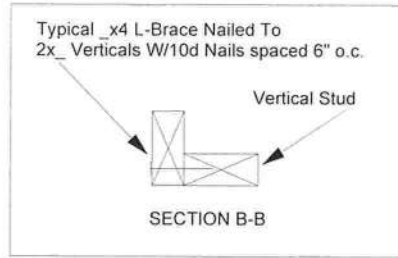
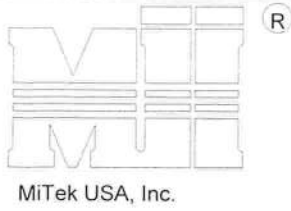

PROVIDE 2x4 BLOCKING BETWEEN THE FIRST TWO TRUSSES AS NOTED. TOENAIL BLOCKING TO TRUSSES WITH (2) - 10d NAILS AT EACH END. ATTACH DIAGONAL BRACE TO BLOCKING WITH (5) - 10d NAILS.

(4) - 8d (0.131" X 2.5") NAILS MINIMUM, PLYWOOD SHEATHING TO 2x4 STD SPF BLOCK

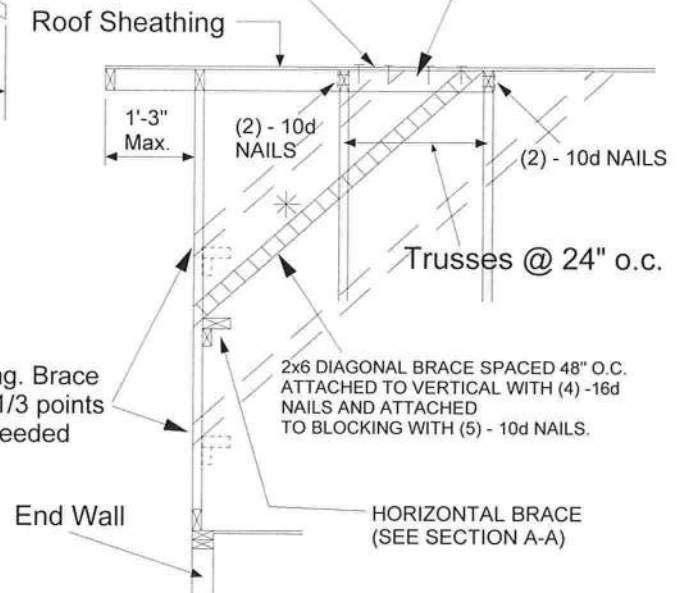

- NOTE:
1. MINIMUM GRADE OF #2 MATERIAL IN THE TOP AND BOTTOM CHORDS.
 2. CONNECTION BETWEEN BOTTOM CHORD OF GABLE END TRUSS AND WALL TO BE PROVIDED BY PROJECT ENGINEER OR ARCHITECT.
 3. BRACING SHOWN IS FOR INDIVIDUAL TRUSS ONLY. CONSULT BLDG. ARCHITECT OR ENGINEER FOR TEMPORARY AND PERMANENT BRACING OF ROOF SYSTEM.
 4. "L" BRACES SPECIFIED ARE TO BE FULL LENGTH. GRADES: 1x4 SRB OR 2x4 STUD OR BETTER WITH ONE ROW OF 10d NAILS SPACED 6" O.C.
 5. DIAGONAL BRACE TO BE APPROXIMATELY 45 DEGREES TO ROOF DIAPHRAM AT 4'-0" O.C.
 6. CONSTRUCT HORIZONTAL BRACE CONNECTING A 2x6 STUD AND A 2x4 STUD AS SHOWN WITH 16d NAILS SPACED 6" O.C. HORIZONTAL BRACE TO BE LOCATED AT THE MIDSPAN OF THE LONGEST STUD. ATTACH TO VERTICAL STUDS WITH (4) 10d NAILS THROUGH 2x4. (REFER TO SECTION A-A)
 7. GABLE STUD DEFLECTION MEETS OR EXCEEDS L/240.
 8. THIS DETAIL DOES NOT APPLY TO STRUCTURAL GABLES.
 9. DO NOT USE FLAT BOTTOM CHORD GABLES NEXT TO SCISSOR TYPE TRUSSES.
 10. SOUTHERN PINE LUMBER DESIGN VALUES ARE THOSE EFFECTIVE 06-01-13 BY SPIB/ALSC.
 11. NAILS DESIGNATED 10d ARE (0.131" X 3") AND NAILS DESIGNATED 16d ARE (0.131" X 3.5")

Minimum Stud Size Species and Grade	Stud Spacing	Without Brace	1x4 L-Brace	2x4 L-Brace	DIAGONAL BRACE	2 DIAGONAL BRACES AT 1/3 POINTS
		Maximum Stud Length				
2x4 SP No. 3 / Stud	12" O.C.	3-9-13	4-1-1	5-9-6	7-1-3	11-5-7
2x4 SP No. 3 / Stud	16" O.C.	3-5-4	3-6-8	5-0-2	6-10-8	10-3-13
2x4 SP No. 3 / Stud	24" O.C.	2-9-11	2-10-11	4-1-1	5-7-6	8-5-1

* Diagonal braces over 6'-3" require a 2x4 T-Brace attached to one edge. Diagonal braces over 12'-6" require 2x4 I-braces attached to both edges. Fasten T and I braces to narrow edge of diagonal brace with 10d nails 8" o.c., with 3" minimum end distance. Brace must cover 90% of diagonal length.

MAX MEAN ROOF HEIGHT = 30 FEET
CATEGORY II BUILDING
EXPOSURE D
ASCE 7-98, ASCE 7-02, ASCE 7-05 130 MPH
ASCE 7-10, ASCE 7-16 160 MPH
DURATION OF LOAD INCREASE 1.60

STUD DESIGN IS BASED ON COMPONENTS AND CLADDING.
CONNECTION OF BRACING IS BASED ON MWFRS.

Design valid for use only with MiTek® connectors. This design is based only upon parameters shown, and is for an individual building component, not a truss system. Before use, the building designer must verify the applicability of design parameters and properly incorporate this design into the overall building design. Bracing indicated is to prevent buckling of individual truss web and/or chord members only. Additional temporary and permanent bracing is always required for stability and to prevent collapse with possible personal injury and property damage. For general guidance regarding the fabrication, storage, delivery, erection and bracing of trusses and truss systems, see ANSIT/PTI Quality Criteria, DSB-89 and BCSI Building Component Safety Information available from Truss Plate Institute, 2670 Crain Highway, Suite 203 Waldorf, MD 20601

This item has been electronically signed and sealed by O'Regan, Philip, PI using a Digital Signature. Printed copies of this document are not considered signed and sealed and the signature must be verified on any electronic copies.

Philip J. O'Regan PE No.58126
MiTek USA, Inc. FL Cert 6634
6904 Parke East Blvd. Tampa FL 33610
Date:

April 2, 2020



6904 Parke East Blvd.
Tampa, FL 36610

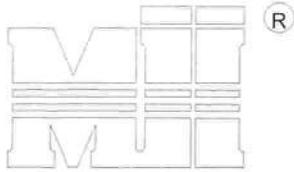

MiTek USA, Inc.

ALTERNATE DIAGONAL BRACING TO THE BOTTOM CHORD

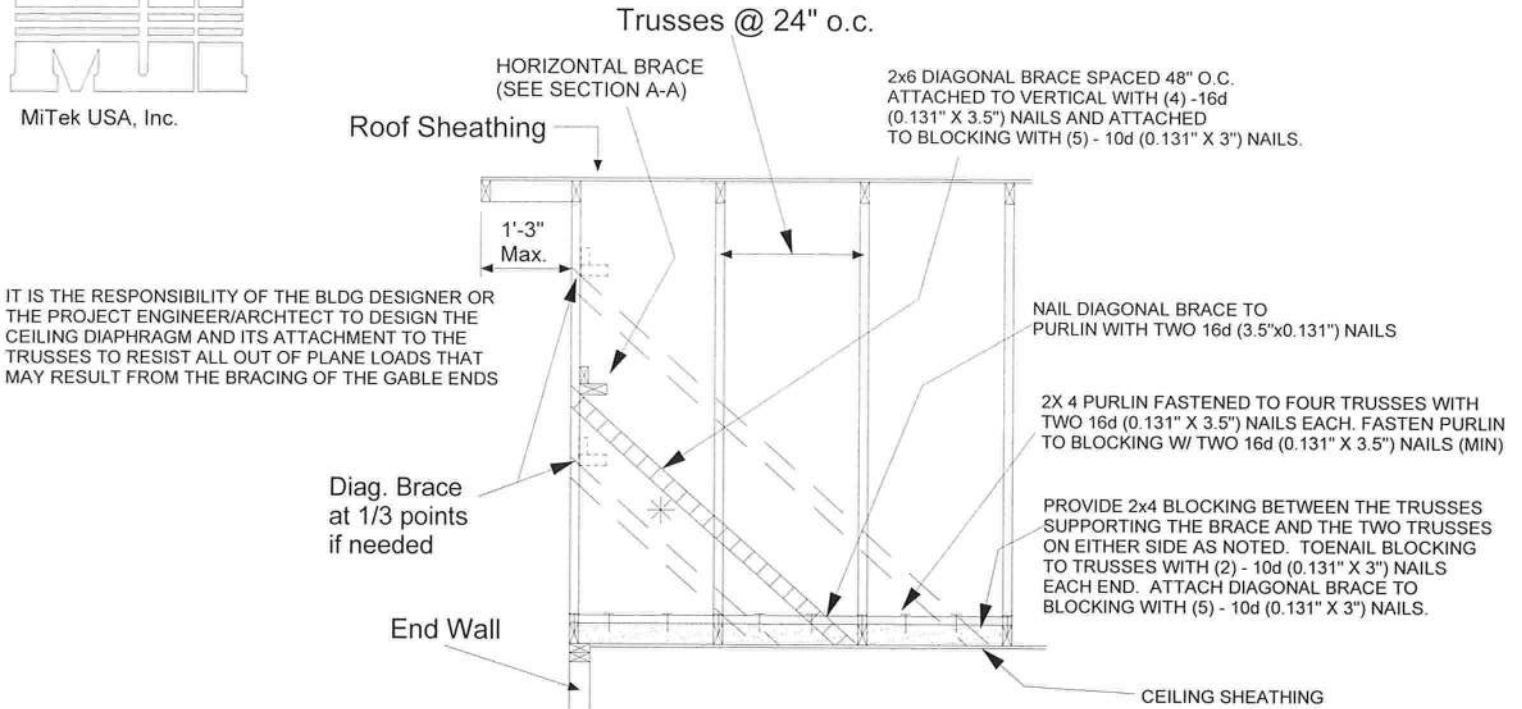

BRACING REQUIREMENTS FOR STRUCTURAL GABLE TRUSSES

STRUCTURAL GABLE TRUSSES MAY BE BRACED AS NOTED:

METHOD 1: ATTACH A MATCHING GABLE TRUSS TO THE INSIDE FACE OF THE STRUCTURAL GABLE AND FASTEN PER THE FOLLOWING NAILING SCHEDULE.

METHOD 2: ATTACH 2X SCABS TO THE FACE OF EACH VERTICAL MEMBER ON THE STRUCTURAL GABLE PER THE FOLLOWING NAILING SCHEDULE. SCABS ARE TO BE OF THE SAME SIZE, GRADE AND SPECIES AS THE TRUSS VERTICALS

NAILING SCHEDULE:

- FOR WIND SPEEDS 120 MPH (ASCE 7-98, 02, 05), 150 MPH (ASCE 7-10, 16) OR LESS, NAIL ALL MEMBERS WITH ONE ROW OF 10d (0.131" X 3") NAILS SPACED 6" O.C.
- FOR WIND SPEEDS 120-150 MPH (ASCE 7-98, 02, 05), 150-190 MPH (ASCE 7-10, 16) NAIL ALL MEMBERS WITH TWO ROWS OF 10d (0.131" X 3") NAILS SPACED 6" O.C. (2X 4 STUDS MINIMUM)

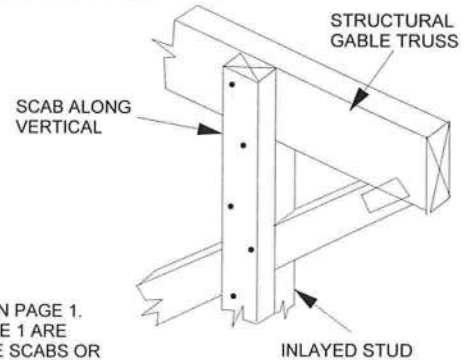

MAXIMUM STUD LENGTHS ARE LISTED ON PAGE 1. ALL BRACING METHODS SHOWN ON PAGE 1 ARE VALID AND ARE TO BE FASTENED TO THE SCABS OR VERTICAL STUDS OF THE STANDARD GABLE TRUSS ON THE INTERIOR SIDE OF THE STRUCTURE.

STRUCTURAL GABLE TRUSS

AN ADEQUATE DIAPHRAGM OR OTHER METHOD OF BRACING MUST BE PRESENT TO PROVIDE FULL LATERAL SUPPORT OF THE BOTTOM CHORD TO RESIST ALL OUT OF PLANE LOADS. THE BRACING SHOWN IN THIS DETAIL IS FOR THE VERTICAL/STUDS ONLY.

NOTE: THIS DETAIL IS TO BE USED ONLY FOR STRUCTURAL GABLES WITH INLAVED STUDS. TRUSSES WITHOUT INLAVED STUDS ARE NOT ADDRESSED HERE.

STANDARD GABLE TRUSS

This item has been electronically signed and sealed by O'Regan, Philip, PE using a Digital Signature. Printed copies of this document are not considered signed and sealed and the signature must be verified on any electronic copies.

Philip J. O'Regan PE No.58126
MiTek USA, Inc. FL Cert 6634
6904 Parke East Blvd. Tampa FL 33610
Date:

April 2, 2021

WARNING - Verify design parameters and READ NOTES ON THIS AND INCLUDED MITEK REFERENCE PAGE MII-7473 rev. 5/19/2020 BEFORE USE

Design valid for use only with MiTek® connectors. This design is based only upon parameters shown, and is for an individual building component, not a truss system. Before use, the building designer must verify the applicability of design parameters and properly incorporate this design into the overall building design. Bracing indicated is to prevent buckling of individual truss web and/or chord members only. Additional temporary and permanent bracing is always required for stability and to prevent collapse with possible personal injury and property damage. For general guidance regarding the fabrication, storage, delivery, erection and bracing of trusses and truss systems, see

ANSI/TPI1 Quality Criteria, DSB-89 and BCSI Building Component

Safety Information available from Truss Plate Institute, 2670 Crain Highway, Suite 203 Waldorf, MD 20601



6904 Parke East Blvd.
Tampa, FL 36610

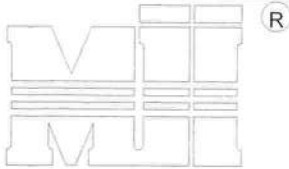

MiTek USA, Inc.

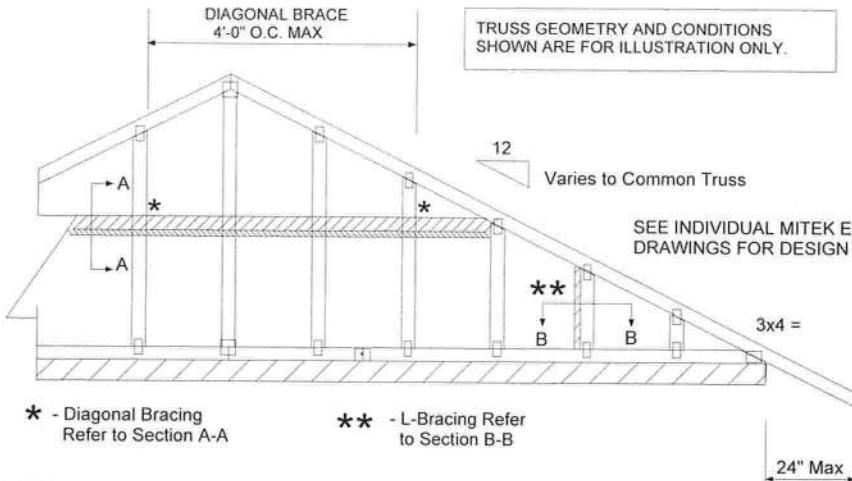
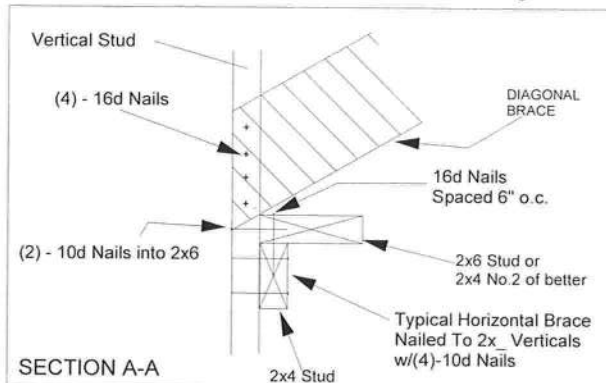
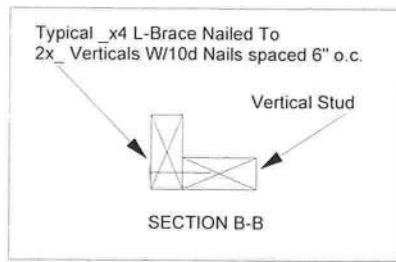

PROVIDE 2x4 BLOCKING BETWEEN THE FIRST TWO TRUSSES AS NOTED. TOENAIL BLOCKING TO TRUSSES WITH (2) - 10d NAILS AT EACH END. ATTACH DIAGONAL BRACE TO BLOCKING WITH (5) - 10d NAILS.

(4) - 8d (0.131" X 2.5") NAILS MINIMUM, PLYWOOD SHEATHING TO 2x4 STD SPF BLOCK

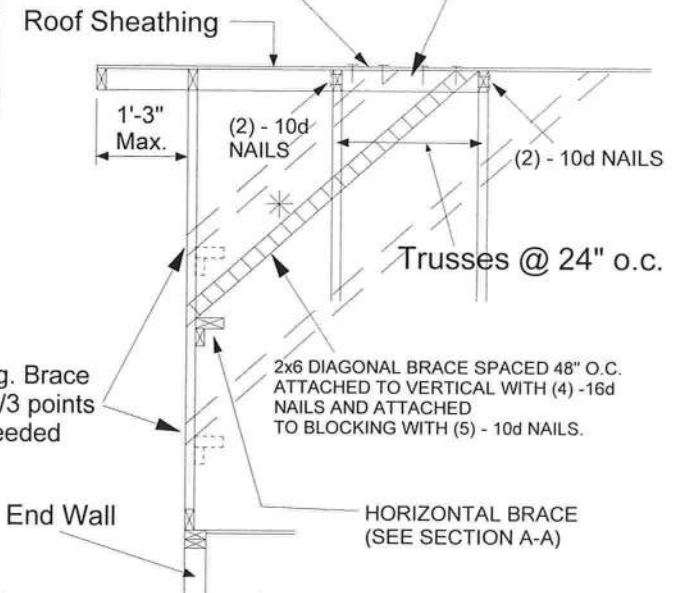

- NOTE:
1. MINIMUM GRADE OF #2 MATERIAL IN THE TOP AND BOTTOM CHORDS.
 2. CONNECTION BETWEEN BOTTOM CHORD OF GABLE END TRUSS AND WALL TO BE PROVIDED BY PROJECT ENGINEER OR ARCHITECT.
 3. BRACING SHOWN IS FOR INDIVIDUAL TRUSS ONLY. CONSULT BLDG. ARCHITECT OR ENGINEER FOR TEMPORARY AND PERMANENT BRACING OF ROOF SYSTEM.
 4. "L" BRACES SPECIFIED ARE TO BE FULL LENGTH. GRADES: 1x4 SRB OR 2x4 STUD OR BETTER WITH ONE ROW OF 10d NAILS SPACED 6" O.C.
 5. DIAGONAL BRACE TO BE APPROXIMATELY 45 DEGREES TO ROOF DIAPHRAM AT 4'-0" O.C.
 6. CONSTRUCT HORIZONTAL BRACE CONNECTING A 2x6 STUD AND A 2x4 STUD AS SHOWN WITH 16d NAILS SPACED 6" O.C. HORIZONTAL BRACE TO BE LOCATED AT THE MIDSPAN OF THE LONGEST STUD. ATTACH TO VERTICAL STUDS WITH (4) 10d NAILS THROUGH 2x4. (REFER TO SECTION A-A)
 7. GABLE STUD DEFLECTION MEETS OR EXCEEDS L/240.
 8. THIS DETAIL DOES NOT APPLY TO STRUCTURAL GABLES.
 9. DO NOT USE FLAT BOTTOM CHORD GABLES NEXT TO SCISSOR TYPE TRUSSES.
 10. SOUTHERN PINE LUMBER DESIGN VALUES ARE THOSE EFFECTIVE 06-01-13 BY SPIB/ALSC.
 11. NAILS DESIGNATED 10d ARE (0.131" X 3") AND NAILS DESIGNATED 16d ARE (0.131" X 3.5")

Minimum Stud Size Species and Grade	Stud Spacing	Without Brace	1x4 L-Brace	2x4 L-Brace	DIAGONAL BRACE	2 DIAGONAL BRACES AT 1/3 POINTS
2x4 SP No. 3 / Stud	12" O.C.	4-0-7	4-5-6	6-3-8	8-0-15	12-1-6
2x4 SP No. 3 / Stud	16" O.C.	3-8-0	3-10-4	5-5-6	7-4-1	11-0-1
2x4 SP No. 3 / Stud	24" O.C.	3-0-10	3-1-12	4-5-6	6-1-5	9-1-15

* Diagonal braces over 6'-3" require a 2x4 T-Brace attached to one edge. Diagonal braces over 12'-6" require 2x4 I-braces attached to both edges. Fasten T and I braces to narrow edge of diagonal brace with 10d nails 8" o.c., with 3" minimum end distance. Brace must cover 90% of diagonal length.

MAX MEAN ROOF HEIGHT = 30 FEET
CATEGORY II BUILDING
EXPOSURE B or C
ASCE 7-98, ASCE 7-02, ASCE 7-05, 130 MPH

ASCE 7-10, ASCE 7-16 160 MPH
DURATION OF LOAD INCREASE 1.60 READ NOT CONNECTION OF BRACING IS BASED ON MWFRS, rev. 5/19/2020 BEFORE USE

Design valid for use only with MiTek® connectors. This design is based only upon parameters shown, and is for an individual building component, not a truss system. Before use, the building designer must verify the applicability of design parameters and properly incorporate this design into the overall building design. Bracing indicated is to prevent buckling of individual truss web and/or chord members only. Additional temporary and permanent bracing is always required for stability and to prevent collapse with possible personal injury and property damage. For general guidance regarding the fabrication, storage, delivery, erection and bracing of trusses and truss systems, see ANSITPI1 Quality Criteria, DSB-89 and BCSI Building Component Safety information available from Truss Plate Institute, 2670 Crain Highway, Suite 203 Waldorf, MD 20601

This item has been electronically signed and sealed by O'Regan, Philip, PE using a Digital Signature. Printed copies of this document are not considered signed and sealed and the signature must be verified on any electronic copies.

Philip J. O'Regan PE No.58126
MiTek USA, Inc. FL Cert 6634
6904 Parke East Blvd. Tampa FL 33610
Date:

April 2, 2021



6904 Parke East Blvd.
Tampa, FL 33610



ALTERNATE DIAGONAL BRACING TO THE BOTTOM CHORD

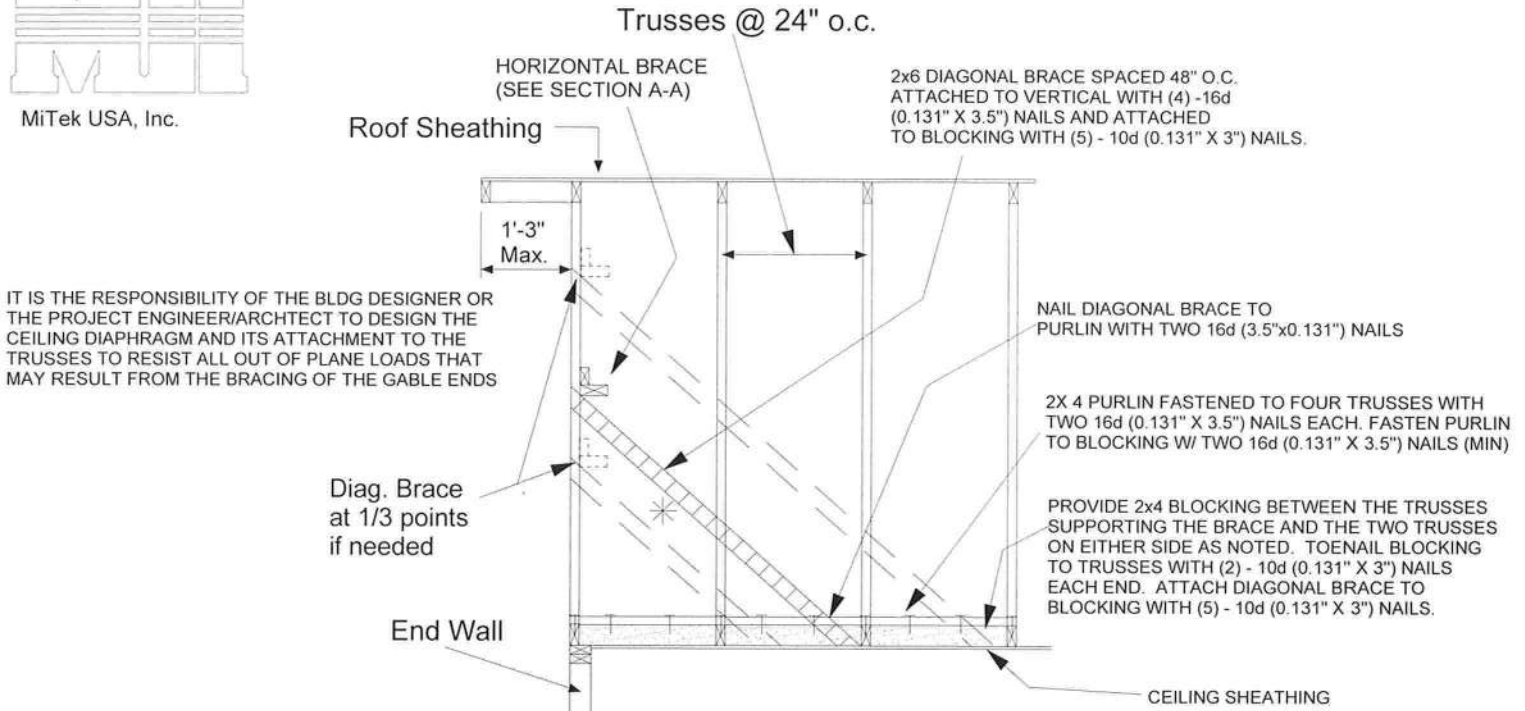

IT IS THE RESPONSIBILITY OF THE BLDG DESIGNER OR THE PROJECT ENGINEER/ARCHTECT TO DESIGN THE CEILING DIAPHRAGM AND ITS ATTACHMENT TO THE TRUSSES TO RESIST ALL OUT OF PLANE LOADS THAT MAY RESULT FROM THE BRACING OF THE GABLE ENDS

BRACING REQUIREMENTS FOR STRUCTURAL GABLE TRUSSES

STRUCTURAL GABLE TRUSSES MAY BE BRACED AS NOTED:

METHOD 1 : ATTACH A MATCHING GABLE TRUSS TO THE INSIDE FACE OF THE STRUCTURAL GABLE AND FASTEN PER THE FOLLOWING NAILING SCHEDULE.

METHOD 2 : ATTACH 2X SCABS TO THE FACE OF EACH VERTICAL MEMBER ON THE STRUCTURAL GABLE PER THE FOLLOWING NAILING SCHEDULE. SCABS ARE TO BE OF THE SAME SIZE, GRADE AND SPECIES AS THE TRUSS VERTICALS

NAILING SCHEDULE:

- FOR WIND SPEEDS 120 MPH (ASCE 7-98, 02, 05), 150 MPH (ASCE 7-10, 16) OR LESS, NAIL ALL MEMBERS WITH ONE ROW OF 10d (0.131" X 3") NAILS SPACED 6" O.C.
- FOR WIND SPEEDS 120-150 MPH (ASCE 7-98, 02, 05), 150-190 MPH (ASCE 7-10, 16) NAIL ALL MEMBERS WITH TWO ROWS OF 10d (0.131" X 3") NAILS SPACED 6" O.C. (2X 4 STUDS MINIMUM)

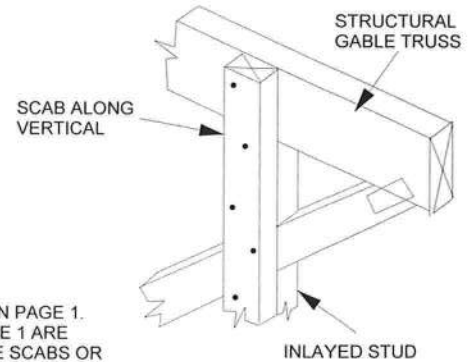

MAXIMUM STUD LENGTHS ARE LISTED ON PAGE 1. ALL BRACING METHODS SHOWN ON PAGE 1 ARE VALID AND ARE TO BE FASTENED TO THE SCABS OR VERTICAL STUDS OF THE STANDARD GABLE TRUSS ON THE INTERIOR SIDE OF THE STRUCTURE.

STRUCTURAL GABLE TRUSS

AN ADEQUATE DIAPHRAGM OR OTHER METHOD OF BRACING MUST BE PRESENT TO PROVIDE FULL LATERAL SUPPORT OF THE BOTTOM CHORD TO RESIST ALL OUT OF PLANE LOADS. THE BRACING SHOWN IN THIS DETAIL IS FOR THE VERTICAL STUDS ONLY.

NOTE : THIS DETAIL IS TO BE USED ONLY FOR STRUCTURAL GABLES WITH INLAIED STUDS. TRUSSES WITHOUT INLAIED STUDS ARE NOT ADDRESSED HERE.

STANDARD GABLE TRUSS

This item has been electronically signed and sealed by O'Regan, Philip, P using a Digital Signature. Printed copies of this document are not considered signed and sealed and the signature must be verified on any electronic copies.

Philip J. O'Regan PE No.58126
MiTek USA, Inc. FL Cert 6634
6904 Parke East Blvd. Tampa FL 33610
Date:

April 2,202

WARNING - Verify design parameters and READ NOTES ON THIS AND INCLUDED MITEK REFERENCE PAGE MII-7473 rev. 5/19/2020 BEFORE USE.

Design valid for use only with MiTek® connectors. This design is based only upon parameters shown, and is for an individual building component, not a truss system. Before use, the building designer must verify the applicability of design parameters and properly incorporate this design into the overall building design. Bracing indicated is to prevent buckling of individual truss web and/or chord members only. Additional temporary and permanent bracing is always required for stability and to prevent collapse with possible personal injury and property damage. For general guidance regarding the fabrication, storage, delivery, erection and bracing of trusses and truss systems, see

ANSI/TPI1 Quality Criteria, DSB-89 and BCSI Building Component

Safety Information available from Truss Plate Institute, 2670 Crain Highway, Suite 203 Waldorf, MD 20601



6904 Parke East Blvd.
Tampa, FL 36610

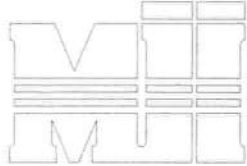

MiTek USA, Inc.

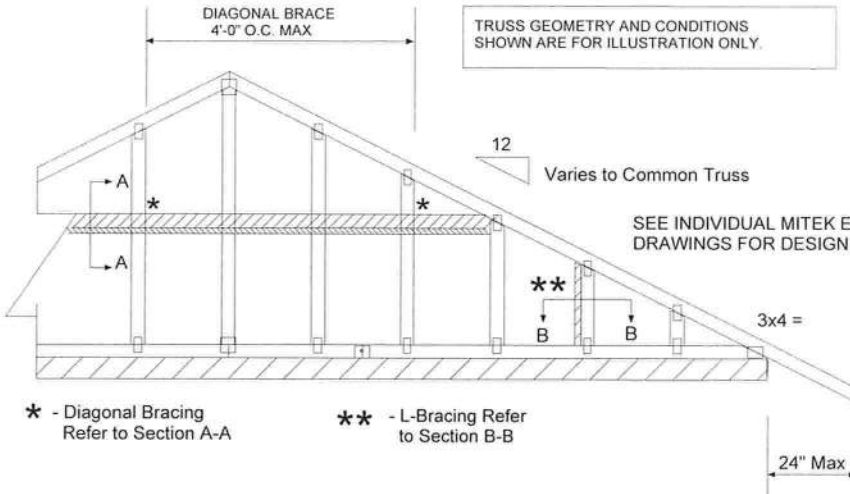
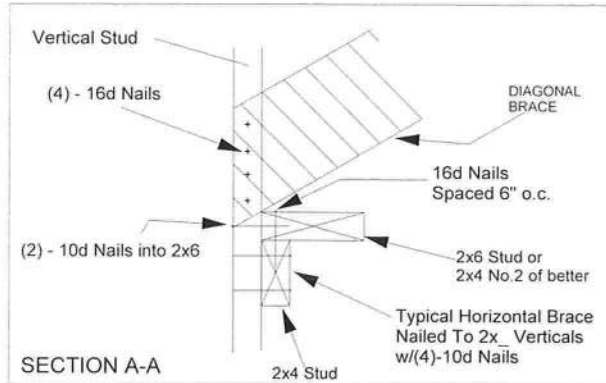
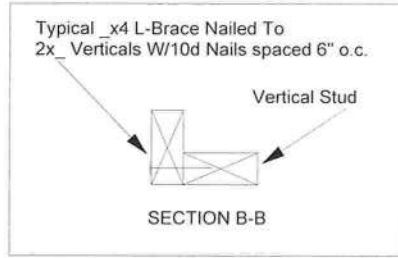

PROVIDE 2x4 BLOCKING BETWEEN THE FIRST TWO TRUSSES AS NOTED. TOENAIL BLOCKING TO TRUSSES WITH (2) - 10d NAILS AT EACH END. ATTACH DIAGONAL BRACE TO BLOCKING WITH (5) - 10d NAILS.

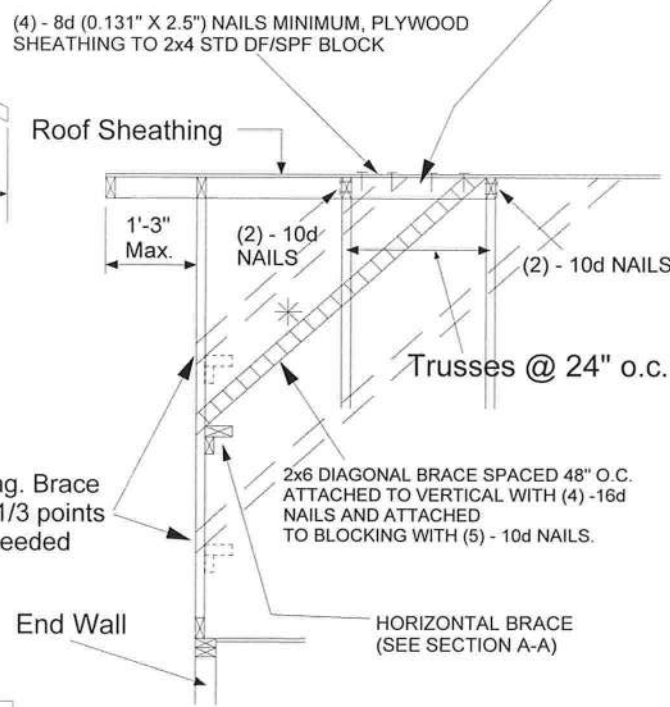

- NOTE:
1. MINIMUM GRADE OF #2 MATERIAL IN THE TOP AND BOTTOM CHORDS.
 2. CONNECTION BETWEEN BOTTOM CHORD OF GABLE END TRUSS AND WALL TO BE PROVIDED BY PROJECT ENGINEER OR ARCHITECT.
 3. BRACING SHOWN IS FOR INDIVIDUAL TRUSS ONLY. CONSULT BLDG. ARCHITECT OR ENGINEER FOR TEMPORARY AND PERMANENT BRACING OF ROOF SYSTEM.
 4. "L" BRACES SPECIFIED ARE TO BE FULL LENGTH. GRADES: 1x4 SRB OR 2x4 STUD OR BETTER WITH ONE ROW OF 10d NAILS SPACED 6" O.C.
 5. DIAGONAL BRACE TO BE APPROXIMATELY 45 DEGREES TO ROOF DIAPHRAM AT 4'-0" O.C.
 6. CONSTRUCT HORIZONTAL BRACE CONNECTING A 2x6 STUD AND A 2x4 STUD AS SHOWN WITH 16d NAILS SPACED 6" O.C. HORIZONTAL BRACE TO BE LOCATED AT THE MIDSPAN OF THE LONGEST STUD. ATTACH TO VERTICAL STUDS WITH (4) 10d NAILS THROUGH 2x4. (REFER TO SECTION A-A)
 7. GABLE STUD DEFLECTION MEETS OR EXCEEDS L/240.
 8. THIS DETAIL DOES NOT APPLY TO STRUCTURAL GABLES.
 9. DO NOT USE FLAT BOTTOM CHORD GABLES NEXT TO SCISSOR TYPE TRUSSES.
 10. NAILS DESIGNATED 10d ARE (0.131" X 3") AND NAILS DESIGNATED 16d ARE (0.131" X 3.5")

Minimum Stud Size Species and Grade	Stud Spacing	Without Brace	1x4 L-Brace	2x4 L-Brace	DIAGONAL BRACE	2 DIAGONAL BRACES AT 1/3 POINTS
2x4 DF/SPF Std/Stud	12" O.C.	3-10-1	3-11-7	5-7-2	7-8-2	11-6-4
2x4 DF/SPF Std/Stud	16" O.C.	3-3-14	3-5-1	4-10-2	6-7-13	9-11-11
2x4 DF/SPF Std/Stud	24" O.C.	2-8-9	2-9-8	3-11-7	5-5-2	8-1-12

* Diagonal braces over 6'-3" require a 2x4 T-Brace attached to one edge. Diagonal braces over 12'-6" require 2x4 I-braces attached to both edges. Fasten T and I braces to narrow edge of web with 10d nails 8" o.c., with 3" minimum end distance. Brace must cover 90% of diagonal length.

This item has been electronically signed and sealed by O'Regan, Philip, P using a Digital Signature. Printed copies of this document are not considered signed and sealed and the signature must be verified on any electronic copies.

Philip J. O'Regan PE No. 58126
MiTek USA, Inc. FL Cert 6634
6904 Parke East Blvd. Tampa FL 33610
Date:

April 2, 2022

MAXIMUM WIND SPEED = 140 MPH
MAX MEAN ROOF HEIGHT = 30 FEET
CATEGORY II BUILDING
EXPOSURE B or C

ASCE 7-98, ASCE 7-02, ASCE 7-05
DURATION OF LOAD INCREASE = 1.60 READ

STUD DESIGN IS BASED ON COMPONENTS AND CLADDING.
CONNECTION OF BRACING IS BASED ON MWFRS 173 rev. 5/19/2020 BEFORE USE.

Design valid for use only with MiTek® connectors. This design is based only upon parameters shown, and is for an individual building component, not a truss system. Before use, the building designer must verify the applicability of design parameters and properly incorporate this design into the overall building design. Bracing indicated is to prevent buckling of individual truss web and/or chord members only. Additional temporary and permanent bracing is always required for stability and to prevent collapse with possible personal injury and property damage. For general guidance regarding the fabrication, storage, delivery, erection and bracing of trusses and truss systems, see ANSIT/PI1 Quality Criteria, DSB-89 and BCSI Building Component Safety Information available from Truss Plate Institute, 2670 Crain Highway, Suite 203 Waldorf, MD 20601



6904 Parke East Blvd.
Tampa, FL 36610

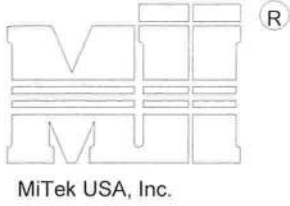

ALTERNATE DIAGONAL BRACING TO THE BOTTOM CHORD

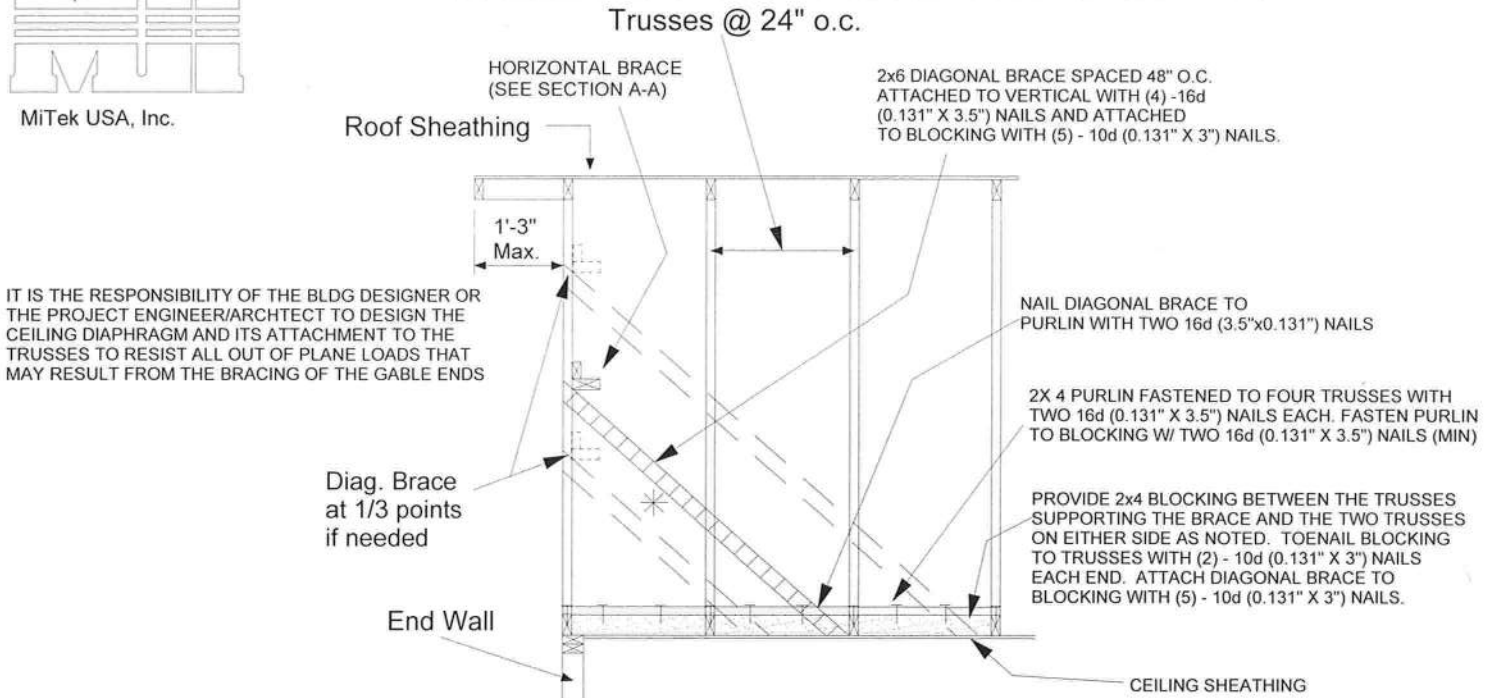

BRACING REQUIREMENTS FOR STRUCTURAL GABLE TRUSSES

- STRUCTURAL GABLE TRUSSES MAY BE BRACED AS NOTED:
- METHOD 1 : ATTACH A MATCHING GABLE TRUSS TO THE INSIDE FACE OF THE STRUCTURAL GABLE AND FASTEN PER THE FOLLOWING NAILING SCHEDULE.
- METHOD 2 : ATTACH 2X SCABS TO THE FACE OF EACH VERTICAL MEMBER ON THE STRUCTURAL GABLE PER THE FOLLOWING NAILING SCHEDULE. SCABS ARE TO BE OF THE SAME SIZE, GRADE AND SPECIES AS THE TRUSS VERTICALS
- NAILING SCHEDULE:
- FOR WIND SPEEDS 120 MPH (ASCE 7-98, 02, 05), 150 MPH (ASCE 7-10, 16) OR LESS, NAIL ALL MEMBERS WITH ONE ROW OF 10d (0.131" X 3") NAILS SPACED 6" O.C.
 - FOR WIND SPEEDS 120-150 MPH (ASCE 7-98, 02, 05), 150-190 MPH (ASCE 7-10, 16) NAIL ALL MEMBERS WITH TWO ROWS OF 10d (0.131" X 3") NAILS SPACED 6" O.C. (2X 4 STUDS MINIMUM)

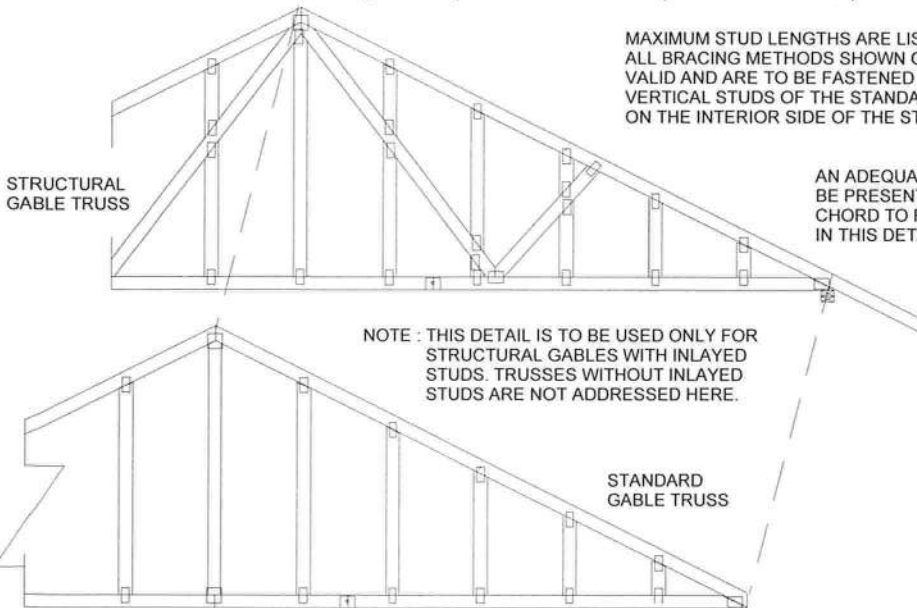
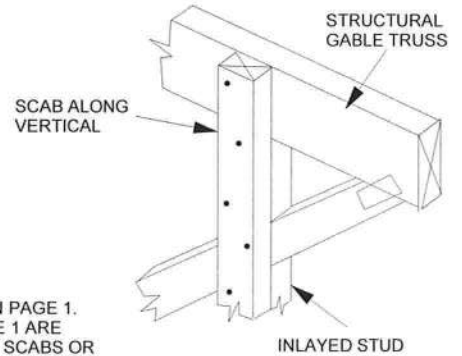

This item has been electronically signed and sealed by O'Regan, Philip, P using a Digital Signature. Printed copies of this document are not considered signed and sealed and the signature must be verified on any electronic copies.

Philip J. O'Regan PE No.58126
MiTek USA, Inc. FL Cert 6634
6904 Parke East Blvd. Tampa FL 33610
Date:

April 2,202

WARNING - Verify design parameters and READ NOTES ON THIS AND INCLUDED MITEK REFERENCE PAGE MII-7473 rev. 5/19/2020 BEFORE USE.

Design valid for use only with MiTek® connectors. This design is based only upon parameters shown, and is for an individual building component, not a truss system. Before use, the building designer must verify the applicability of design parameters and properly incorporate this design into the overall building design. Bracing indicated is to prevent buckling of individual truss web and/or chord members only. Additional temporary and permanent bracing is always required for stability and to prevent collapse with possible personal injury and property damage. For general guidance regarding the fabrication, storage, delivery, erection and bracing of trusses and truss systems, see **ANSI/TPI1 Quality Criteria, DSB-89 and BCSI Building Component Safety Information** available from Truss Plate Institute, 2670 Crain Highway, Suite 203 Waldorf, MD 20601



6904 Parke East Blvd.
Tampa, FL 36610

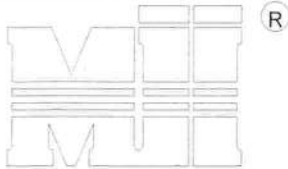

MiTek USA, Inc.

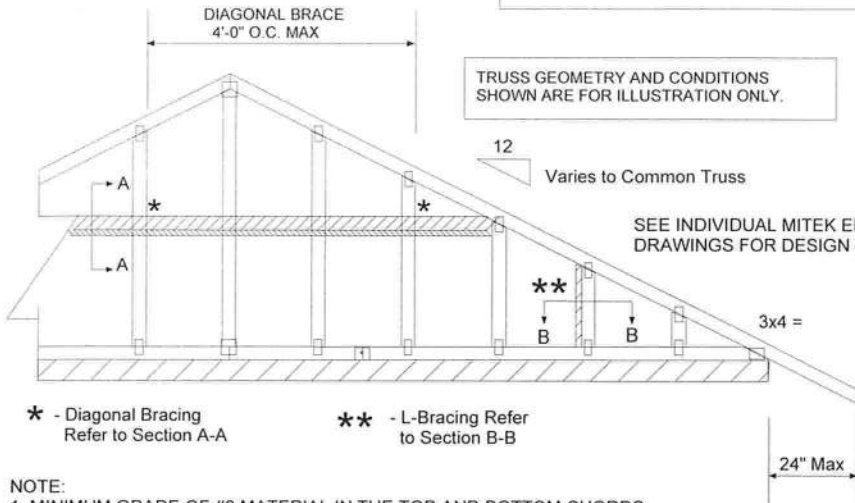
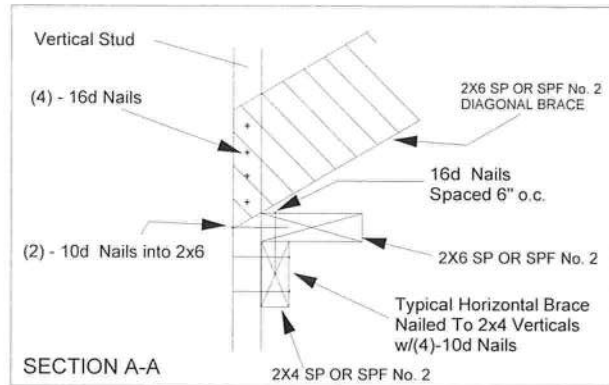
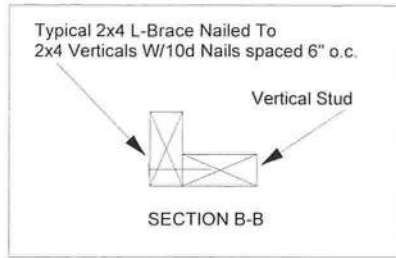

PROVIDE 2x4 BLOCKING BETWEEN THE FIRST TWO TRUSSES AS NOTED. TOENAIL BLOCKING TO TRUSSES WITH (2) - 10d NAILS AT EACH END. ATTACH DIAGONAL BRACE TO BLOCKING WITH (5) - 10d NAILS.

(4) - 8d (0.131" X 2.5") NAILS MINIMUM, PLYWOOD SHEATHING TO 2x4 STD SPF BLOCK

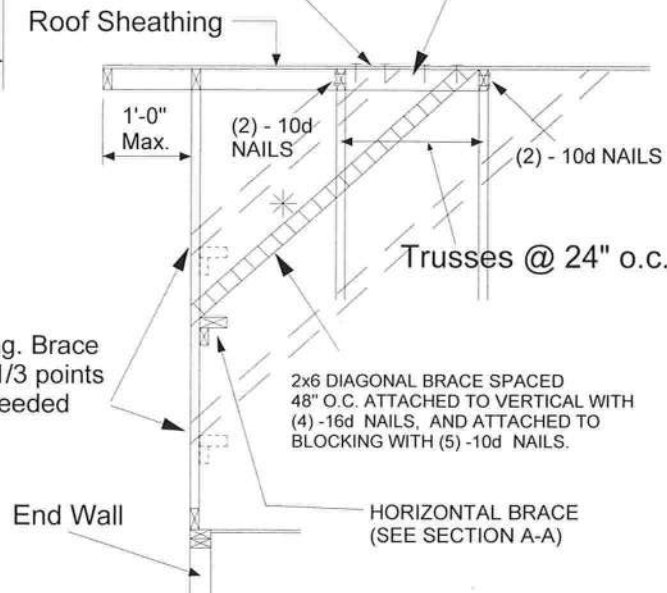

- NOTE:
- MINIMUM GRADE OF #2 MATERIAL IN THE TOP AND BOTTOM CHORDS.
 - CONNECTION BETWEEN BOTTOM CHORD OF GABLE END TRUSS AND WALL TO BE PROVIDED BY PROJECT ENGINEER OR ARCHITECT.
 - BRACING SHOWN IS FOR INDIVIDUAL TRUSS ONLY. CONSULT BLDG. ARCHITECT OR ENGINEER FOR TEMPORARY AND PERMANENT BRACING OF ROOF SYSTEM.
 - "L" BRACES SPECIFIED ARE TO BE FULL LENGTH, SPF or SP No.3 OR BETTER WITH ONE ROW OF 10d NAILS SPACED 6" O.C.
 - DIAGONAL BRACE TO BE APPROXIMATELY 45 DEGREES TO ROOF DIAPHRAM AT 4'-0" O.C.
 - CONSTRUCT HORIZONTAL BRACE CONNECTING A 2x6 AND A 2x4 AS SHOWN WITH 16d NAILS SPACED 6" O.C. HORIZONTAL BRACE TO BE LOCATED AT THE MIDSPAN OF THE LONGEST GABLE STUD. ATTACH TO VERTICAL GABLE STUDS WITH (4) 10d NAILS THROUGH 2x4. (REFER TO SECTION A-A)
 - GABLE STUD DEFLECTION MEETS OR EXCEEDS L/240.
 - THIS DETAIL DOES NOT APPLY TO STRUCTURAL GABLES.
 - DO NOT USE FLAT BOTTOM CHORD GABLES NEXT TO SCISSOR TYPE TRUSSES.
 - SOUTHERN PINE LUMBER DESIGN VALUES ARE THOSE EFFECTIVE 06-01-13 BY SPIB/ALSC.
 - NAILS DESIGNATED 10d ARE (0.131" X 3") AND NAILS DESIGNATED 16d ARE (0.131" X 3.5")

Minimum Stud Size Species and Grade	Stud Spacing	Without Brace	2x4 L-Brace	DIAGONAL BRACE	2 DIAGONAL BRACES AT 1/3 POINTS
2x4 SP No. 3 / Stud	12" O.C.	3-9-7	5-8-8	6-11-1	11-4-4
2x4 SP No. 3 / Stud	16" O.C.	3-4-12	4-11-15	6-9-8	10-2-3
2x4 SP No. 3 / Stud	24" O.C.	2-9-4	4-0-7	5-6-8	8-3-13
2x4 SP No. 2	12" O.C.	3-11-13	5-8-8	6-11-1	11-11-7
2x4 SP No. 2	16" O.C.	3-7-7	4-11-5	6-11-1	10-10-5
2x4 SP No. 2	24" O.C.	3-1-15	4-0-7	6-3-14	9-5-14

* Diagonal braces over 6'-3" require a 2x4 T-Brace attached to one edge. Diagonal braces over 12'-6" require 2x4 I-braces attached to both edges. Fasten T and I braces to narrow edge of diagonal brace with 10d nails 6" o.c., with 3" minimum end distance. Brace must cover 90% of diagonal length. T or I braces must be 2x4 SPF No. 2 or SP No. 2.

This item has been electronically signed and sealed by O'Regan, Philip, Pt using a Digital Signature. Printed copies of this document are not considered signed and sealed and the signature must be verified on any electronic copies.

Philip J. O'Regan PE No.58126
MiTek USA, Inc. FL Cert 6634
6904 Parke East Blvd. Tampa FL 33610
Date:

April 2, 2020

MAX MEAN ROOF HEIGHT = 30 FEET
EXPOSURE D
ASCE 7-10, ASCE 7-16 170 MPH
DURATION OF LOAD INCREASE = 1.60

STUD DESIGN IS BASED ON COMPONENTS AND CLADDING
CONNECTION OF BRACING IS BASED ON MWFRS

Design valid for use only with MiTek® connectors. This design is based only upon parameters shown, and is for an individual building component, not a truss system. Before use, the building designer must verify the applicability of design parameters and properly incorporate this design into the overall building design. Bracing indicated is to prevent buckling of individual truss web and/or chord members only. Additional temporary and permanent bracing is always required for stability and to prevent collapse with possible personal injury and property damage. For general guidance regarding the fabrication, storage, delivery, erection and bracing of trusses and truss systems, see ANSIT/TP1 Quality Criteria, DSB-89 and BCSI Building Component Safety Information available from Truss Plate Institute, 2670 Crain Highway, Suite 203 Waldorf, MD 20601



6904 Parke East Blvd.
Tampa, FL 33610

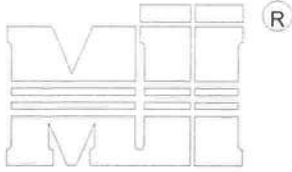

MiTek USA, Inc.

ALTERNATE DIAGONAL BRACING TO THE BOTTOM CHORD

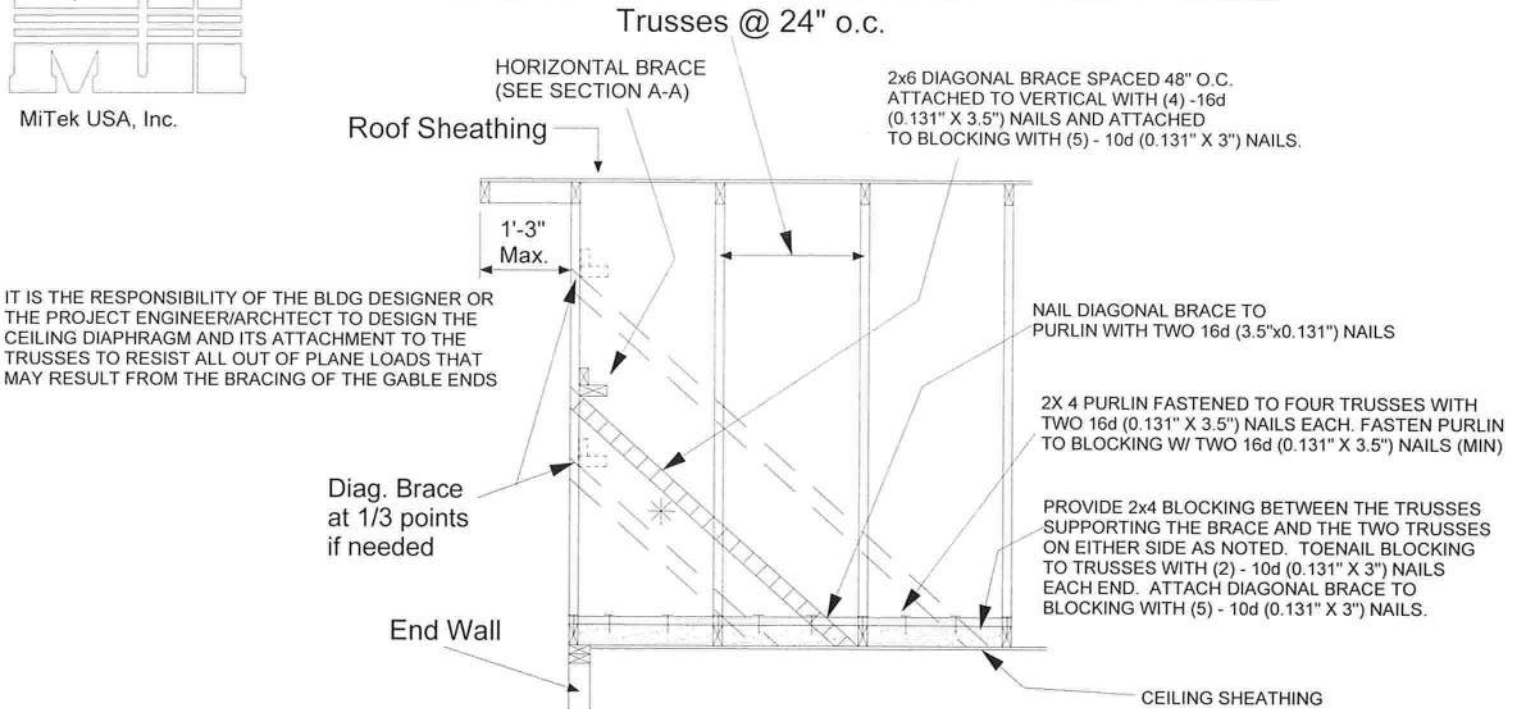

IT IS THE RESPONSIBILITY OF THE BLDG DESIGNER OR THE PROJECT ENGINEER/ARCHTECT TO DESIGN THE CEILING DIAPHRAGM AND ITS ATTACHMENT TO THE TRUSSES TO RESIST ALL OUT OF PLANE LOADS THAT MAY RESULT FROM THE BRACING OF THE GABLE ENDS

BRACING REQUIREMENTS FOR STRUCTURAL GABLE TRUSSES

STRUCTURAL GABLE TRUSSES MAY BE BRACED AS NOTED:

METHOD 1 : ATTACH A MATCHING GABLE TRUSS TO THE INSIDE FACE OF THE STRUCTURAL GABLE AND FASTEN PER THE FOLLOWING NAILING SCHEDULE.

METHOD 2 : ATTACH 2X SCABS TO THE FACE OF EACH VERTICAL MEMBER ON THE STRUCTURAL GABLE PER THE FOLLOWING NAILING SCHEDULE. SCABS ARE TO BE OF THE SAME SIZE, GRADE AND SPECIES AS THE TRUSS VERTICALS

NAILING SCHEDULE:

- FOR WIND SPEEDS 120 MPH (ASCE 7-98, 02, 05), 150 MPH (ASCE 7-10, 16) OR LESS, NAIL ALL MEMBERS WITH ONE ROW OF 10d (0.131" X 3") NAILS SPACED 6" O.C.
- FOR WIND SPEEDS 120-150 MPH (ASCE 7-98, 02, 05), 150-190 MPH (ASCE 7-10, 16) NAIL ALL MEMBERS WITH TWO ROWS OF 10d (0.131" X 3") NAILS SPACED 6" O.C. (2X 4 STUDS MINIMUM)

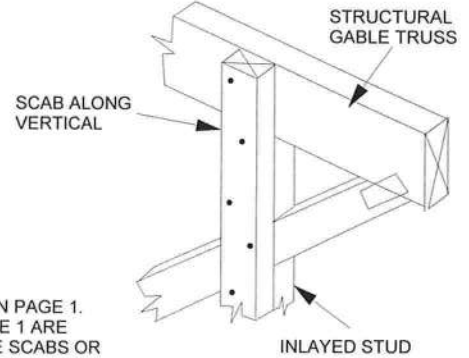

MAXIMUM STUD LENGTHS ARE LISTED ON PAGE 1. ALL BRACING METHODS SHOWN ON PAGE 1 ARE VALID AND ARE TO BE FASTENED TO THE SCABS OR VERTICAL STUDS OF THE STANDARD GABLE TRUSS ON THE INTERIOR SIDE OF THE STRUCTURE.

STRUCTURAL GABLE TRUSS

AN ADEQUATE DIAPHRAGM OR OTHER METHOD OF BRACING MUST BE PRESENT TO PROVIDE FULL LATERAL SUPPORT OF THE BOTTOM CHORD TO RESIST ALL OUT OF PLANE LOADS. THE BRACING SHOWN IN THIS DETAIL IS FOR THE VERTICAL/STUDS ONLY.

NOTE : THIS DETAIL IS TO BE USED ONLY FOR STRUCTURAL GABLES WITH INLAVED STUDS. TRUSSES WITHOUT INLAVED STUDS ARE NOT ADDRESSED HERE.

STANDARD GABLE TRUSS

This item has been electronically signed and sealed by O'Regan, Philip, PE using a Digital Signature. Printed copies of this document are not considered signed and sealed and the signature must be verified on any electronic copies.

Philip J. O'Regan PE No.58126
MiTek USA, Inc. FL Cert 6634
6904 Parke East Blvd. Tampa FL 33610
Date:

April 2,2021

WARNING - Verify design parameters and READ NOTES ON THIS AND INCLUDED MITEK REFERENCE PAGE MII-7473 rev. 5/10/2020 BEFORE USE.

Design valid for use only with MiTek® connectors. This design is based only upon parameters shown, and is for an individual building component, not a truss system. Before use, the building designer must verify the applicability of design parameters and properly incorporate this design into the overall building design. Bracing indicated is to prevent buckling of individual truss web and/or chord members only. Additional temporary and permanent bracing is always required for stability and to prevent collapse with possible personal injury and property damage. For general guidance regarding the fabrication, storage, delivery, erection and bracing of trusses and truss systems, see ANSITP11 Quality Criteria, DSB-89 and BCSI Building Component Safety Information available from Truss Plate Institute, 2670 Crain Highway, Suite 203 Waldorf, MD 20601



6904 Parke East Blvd.
Tampa, FL 36610

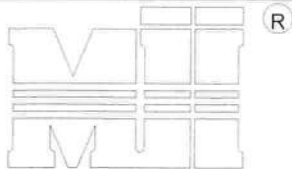

MiTek USA, Inc.

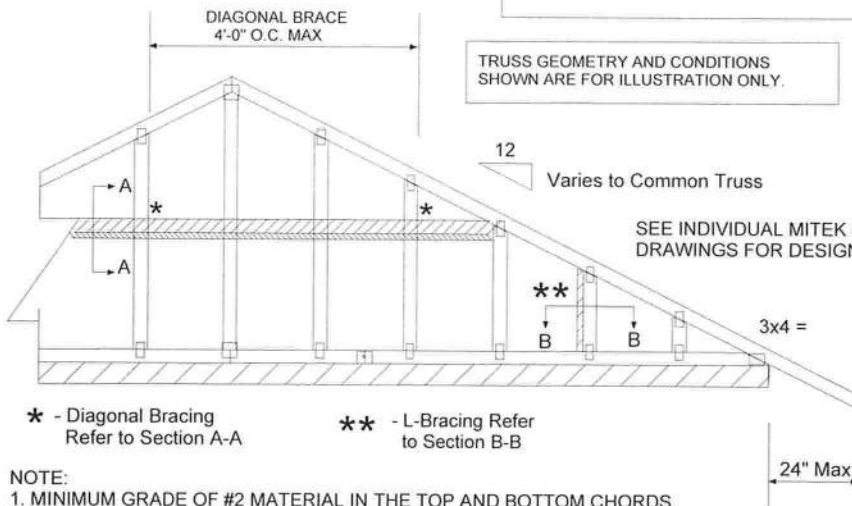
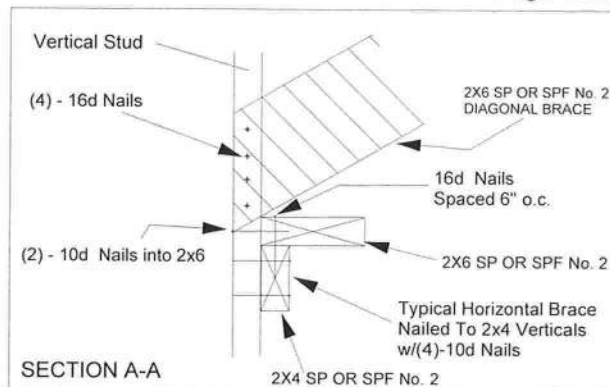
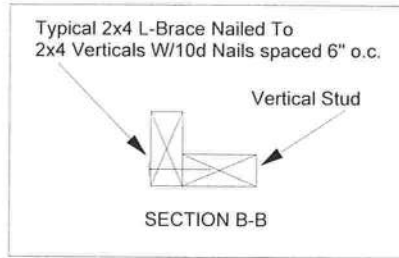

TRUSS GEOMETRY AND CONDITIONS SHOWN ARE FOR ILLUSTRATION ONLY.

SEE INDIVIDUAL MITEK ENGINEERING DRAWINGS FOR DESIGN CRITERIA

PROVIDE 2x4 BLOCKING BETWEEN THE FIRST TWO TRUSSES AS NOTED. TOENAIL BLOCKING TO TRUSSES WITH (2) - 10d NAILS AT EACH END. ATTACH DIAGONAL BRACE TO BLOCKING WITH (5) - 10d NAILS.

(4) - 8d (0.131" X 2.5") NAILS MINIMUM, PLYWOOD SHEATHING TO 2x4 STD SPF BLOCK

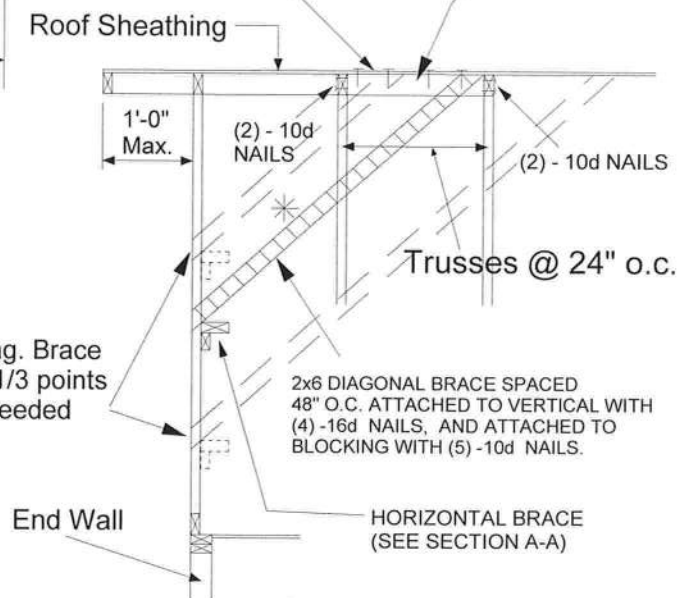

* - Diagonal Bracing Refer to Section A-A
** - L-Bracing Refer to Section B-B

- NOTE:
1. MINIMUM GRADE OF #2 MATERIAL IN THE TOP AND BOTTOM CHORDS.
 2. CONNECTION BETWEEN BOTTOM CHORD OF GABLE END TRUSS AND WALL TO BE PROVIDED BY PROJECT ENGINEER OR ARCHITECT.
 3. BRACING SHOWN IS FOR INDIVIDUAL TRUSS ONLY. CONSULT BLDG. ARCHITECT OR ENGINEER FOR TEMPORARY AND PERMANENT BRACING OF ROOF SYSTEM.
 4. "L" BRACES SPECIFIED ARE TO BE FULL LENGTH, SPF or SP No.3 OR BETTER WITH ONE ROW OF 10d NAILS SPACED 6" O.C.
 5. DIAGONAL BRACE TO BE APPROXIMATELY 45 DEGREES TO ROOF DIAPHRAM AT 4'-0" O.C.
 6. CONSTRUCT HORIZONTAL BRACE CONNECTING A 2x6 AND A 2x4 AS SHOWN WITH 16d NAILS SPACED 6" O.C. HORIZONTAL BRACE TO BE LOCATED AT THE MIDSPAN OF THE LONGEST GABLE STUD. ATTACH TO VERTICAL GABLE STUDS WITH (4) 10d NAILS THROUGH 2x4. (REFER TO SECTION A-A)
 7. GABLE STUD DEFLECTION MEETS OR EXCEEDS L/240.
 8. THIS DETAIL DOES NOT APPLY TO STRUCTURAL GABLES.
 9. DO NOT USE FLAT BOTTOM CHORD GABLES NEXT TO SCISSOR TYPE TRUSSES.
 10. SOUTHERN PINE LUMBER DESIGN VALUES ARE THOSE EFFECTIVE 06-01-13 BY SPIB/ALSC.
 11. NAILS DESIGNATED 10d ARE (0.131" X 3") AND NAILS DESIGNATED 16d ARE (0.131" X 3.5")

Minimum Stud Size Species and Grade	Stud Spacing	Without Brace	2x4 L-Brace	DIAGONAL BRACE	2 DIAGONAL BRACES AT 1/3 POINTS
2x4 SP No. 3 / Stud	12" O.C.	3-7-12	5-4-11	6-2-1	10-11-3
2x4 SP No. 3 / Stud	16" O.C.	3-2-8	4-8-1	6-2-1	9-7-7
2x4 SP No. 3 / Stud	24" O.C.	2-7-7	3-9-12	5-2-13	7-10-4
2x4 SP No. 2	12" O.C.	3-10-0	5-4-11	6-2-1	11-6-1
2x4 SP No. 2	16" O.C.	3-5-13	4-8-1	6-2-1	10-5-7
2x4 SP No. 2	24" O.C.	3-0-8	3-9-12	6-1-1	9-1-9

* Diagonal braces over 6'-3" require a 2x4 T-Brace attached to one edge. Diagonal braces over 12'-6" require 2x4 I-braces attached to both edges. Fasten T and I braces to narrow edge of diagonal brace with 10d nails 6in o.c., with 3in minimum end distance. Brace must cover 90% of diagonal length. T or I braces must be 2x4 SPF No. 2 or SP No. 2.

This item has been electronically signed and sealed by O'Regan, Philip, PI using a Digital Signature. Printed copies of this document are not considered signed and sealed and the signature must be verified on any electronic copies.

Philip J. O'Regan PE No.58126
MiTek USA, Inc. FL Cert 6634
6904 Parke East Blvd. Tampa FL 33610
Date:

April 2, 2020

MAX MEAN ROOF HEIGHT = 30 FEET
EXPOSURE D

ASCE 7-10, ASCE 7-16 180 MPH
DURATION OF LOAD INCREASE = 1.60

STUD DESIGN IS BASED ON COMPONENTS AND CLADDING.
CONNECTION OF BRACING IS BASED ON MWERS.

Design valid for use only with MiTek® connectors. This design is based only upon parameters shown, and is for an individual building component, not a truss system. Before use, the building designer must verify the applicability of design parameters and properly incorporate this design into the overall building design. Bracing indicated is to prevent buckling of individual truss web and/or chord members only. Additional temporary and permanent bracing is always required for stability and to prevent collapse with possible personal injury and property damage. For general guidance regarding the fabrication, storage, delivery, erection and bracing of trusses and truss systems, see ANSITP11 Quality Criteria, DSB-89 and BCSI Building Component Safety Information available from Truss Plate Institute, 2670 Crain Highway, Suite 203 Waldorf, MD 20601



6904 Parke East Blvd.
Tampa, FL 36610

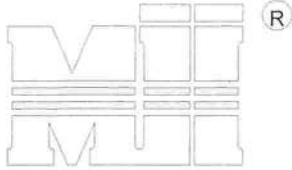

MiTek USA, Inc.

ALTERNATE DIAGONAL BRACING TO THE BOTTOM CHORD

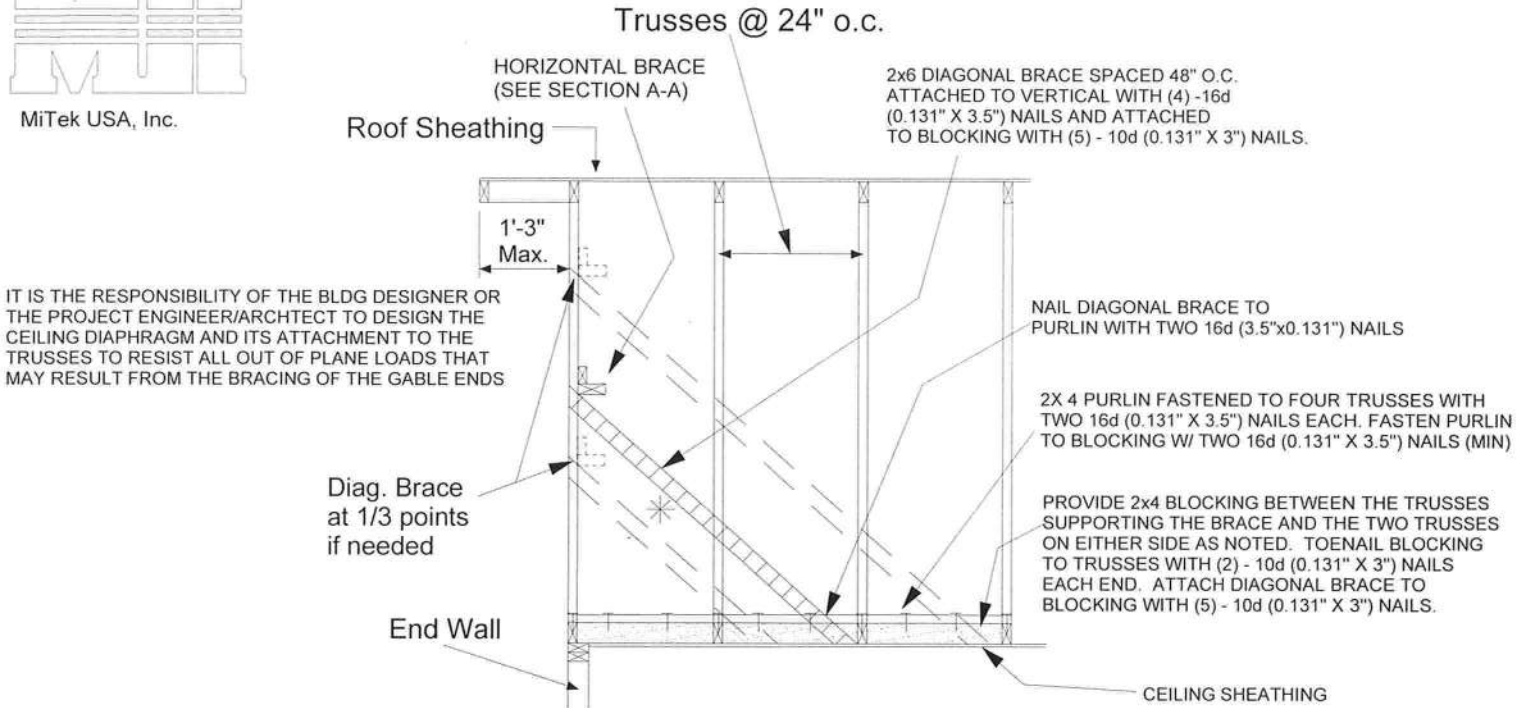

BRACING REQUIREMENTS FOR STRUCTURAL GABLE TRUSSES

STRUCTURAL GABLE TRUSSES MAY BE BRACED AS NOTED:

METHOD 1 : ATTACH A MATCHING GABLE TRUSS TO THE INSIDE FACE OF THE STRUCTURAL GABLE AND FASTEN PER THE FOLLOWING NAILING SCHEDULE.

METHOD 2 : ATTACH 2X SCABS TO THE FACE OF EACH VERTICAL MEMBER ON THE STRUCTURAL GABLE PER THE FOLLOWING NAILING SCHEDULE. SCABS ARE TO BE OF THE SAME SIZE, GRADE AND SPECIES AS THE TRUSS VERTICALS

NAILING SCHEDULE:

- FOR WIND SPEEDS 120 MPH (ASCE 7-98, 02, 05), 150 MPH (ASCE 7-10, 16) OR LESS, NAIL ALL MEMBERS WITH ONE ROW OF 10d (0.131" X 3") NAILS SPACED 6" O.C.
- FOR WIND SPEEDS 120-150 MPH (ASCE 7-98, 02, 05), 150-190 MPH (ASCE 7-10, 16) NAIL ALL MEMBERS WITH TWO ROWS OF 10d (0.131" X 3") NAILS SPACED 6" O.C. (2X 4 STUDS MINIMUM)

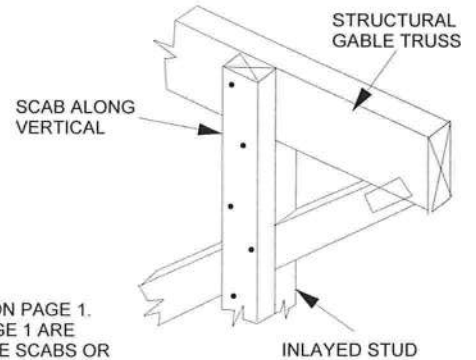

MAXIMUM STUD LENGTHS ARE LISTED ON PAGE 1. ALL BRACING METHODS SHOWN ON PAGE 1 ARE VALID AND ARE TO BE FASTENED TO THE SCABS OR VERTICAL STUDS OF THE STANDARD GABLE TRUSS ON THE INTERIOR SIDE OF THE STRUCTURE.

STRUCTURAL GABLE TRUSS

AN ADEQUATE DIAPHRAGM OR OTHER METHOD OF BRACING MUST BE PRESENT TO PROVIDE FULL LATERAL SUPPORT OF THE BOTTOM CHORD TO RESIST ALL OUT OF PLANE LOADS. THE BRACING SHOWN IN THIS DETAIL IS FOR THE VERTICAL/STUDS ONLY.

NOTE : THIS DETAIL IS TO BE USED ONLY FOR STRUCTURAL GABLES WITH INLAYED STUDS. TRUSSES WITHOUT INLAYED STUDS ARE NOT ADDRESSED HERE.

STANDARD GABLE TRUSS

This item has been electronically signed and sealed by O'Regan, Philip, P using a Digital Signature. Printed copies of this document are not considered signed and sealed and the signature must be verified on any electronic copies.

Philip J. O'Regan PE No.58126
MiTek USA, Inc. FL Cert 6634
6904 Parke East Blvd. Tampa FL 33610
Date:

April 2,202

WARNING - Verify design parameters and READ NOTES ON THIS AND INCLUDED MITEK REFERENCE PAGE MII-7473 rev. 5/19/2020 BEFORE USE.

Design valid for use only with MiTek® connectors. This design is based only upon parameters shown, and is for an individual building component, not a truss system. Before use, the building designer must verify the applicability of design parameters and properly incorporate this design into the overall building design. Bracing indicated is to prevent buckling of individual truss web and/or chord members only. Additional temporary and permanent bracing is always required for stability and to prevent collapse with possible personal injury and property damage. For general guidance regarding the fabrication, storage, delivery, erection and bracing of trusses and truss systems, see **ANSI/TPI1 Quality Criteria, DSB-89 and BCSI Building Component Safety Information** available from Truss Plate Institute, 2670 Crain Highway, Suite 203 Waldorf, MD 20601



6904 Parke East Blvd.
Tampa, FL 36610

January 8, 2019

STANDARD PIGGYBACK TRUSS CONNECTION DETAIL

MII-PIGGY-7-16
T23399815

MiTek USA, Inc. Page 1 of 1

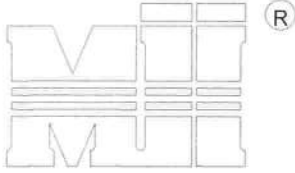

MiTek USA, Inc.

MAXIMUM WIND SPEED = REFER TO NOTES D AND OR E
MAX MEAN ROOF HEIGHT = 30 FEET
MAX TRUSS SPACING = 24" O.C.
CATEGORY II BUILDING
EXPOSURE B or C
ENCLOSED BUILDING
LOADING = 5 PSF TCDL
ASCE 7-10, ASCE 7-16
DURATION OF LOAD INCREASE : 1.60

DETAIL IS NOT APPLICABLE FOR TRUSSES TRANSFERRING DRAG LOADS (SHEAR TRUSSES). ADDITIONAL CONSIDERATIONS BY BUILDING ENGINEER/DESIGNER ARE REQUIRED.

- A - PIGGYBACK TRUSS, REFER TO MITEK TRUSS DESIGN DRAWING. SHALL BE CONNECTED TO EACH PURLIN WITH (2) (0.131" X 3.5") TOE-NAILED.
- B - BASE TRUSS, REFER TO MITEK TRUSS DESIGN DRAWING.
- C - PURLINS AT EACH BASE TRUSS JOINT AND A MAXIMUM 24" O.C. UNLESS SPECIFIED CLOSER ON MITEK TRUSS DESIGN DRAWING. CONNECT TO BASE TRUSS WITH (2) (0.131" X 3.5") NAILS EACH.
- D - 2 X $\frac{1}{2}$ " X 4'-0" SCAB, SIZE TO MATCH TOP CHORD OF PIGGYBACK TRUSS, MIN GRADE #2, ATTACHED TO ONE FACE, CENTERED ON INTERSECTION, WITH (2) ROWS OF (0.131" X 3") NAILS @ 4" O.C. SCAB MAY BE OMITTED PROVIDED THE TOP CHORD SHEATHING IS CONTINUOUS OVER INTERSECTION AT LEAST 1 FT. IN BOTH DIRECTIONS AND:
 1. WIND SPEED OF 115 MPH OR LESS FOR ANY PIGGYBACK SPAN, OR
 2. WIND SPEED OF 116 MPH TO 180 MPH WITH A MAXIMUM PIGGYBACK SPAN OF 12 ft.
- E - FOR WIND SPEEDS BETWEEN 116 AND 180 MPH, ATTACH MITEK NP37 20 GA Nail-On PLATES TO EACH FACE OF TRUSSES AT 72" O.C. W/ (4) (0.131" X 1.5") NAILS PER MEMBER. STAGGER NAILS FROM OPPOSING FACES. ENSURE 0.5" NAIL EDGE DISTANCE. (MIN. 2 PAIRS OF PLATES REQ. REGARDLESS OF SPAN)

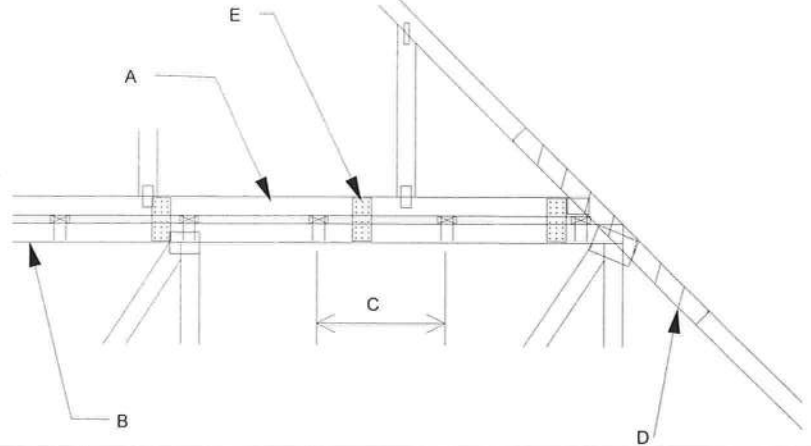

WHEN NO GAP BETWEEN PIGGYBACK AND BASE TRUSS EXISTS:

REPLACE TOE NAILING OF PIGGYBACK TRUSS TO PURLINS WITH Nail-On PLATES AS SHOWN, AND INSTALL PURLINS TO BOTTOM EDGE OF BASE TRUSS TOP CHORD AT SPECIFIED SPACING SHOWN ON BASE TRUSS MITEK DESIGN DRAWING.

SCAB CONNECTION PER NOTE D ABOVE

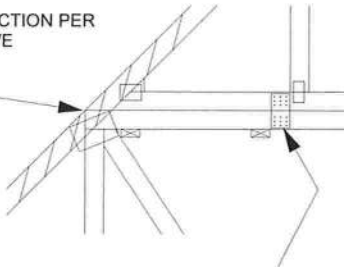

FOR ALL WIND SPEEDS, ATTACH MITEK NP37 20 GA Nail-On PLATES TO EACH FACE OF TRUSSES AT 48" O.C. W/ (4) (0.131" X 1.5") PER MEMBER. STAGGER NAILS FROM OPPOSING FACES ENSURE 0.5" NAIL EDGE DISTANCE.

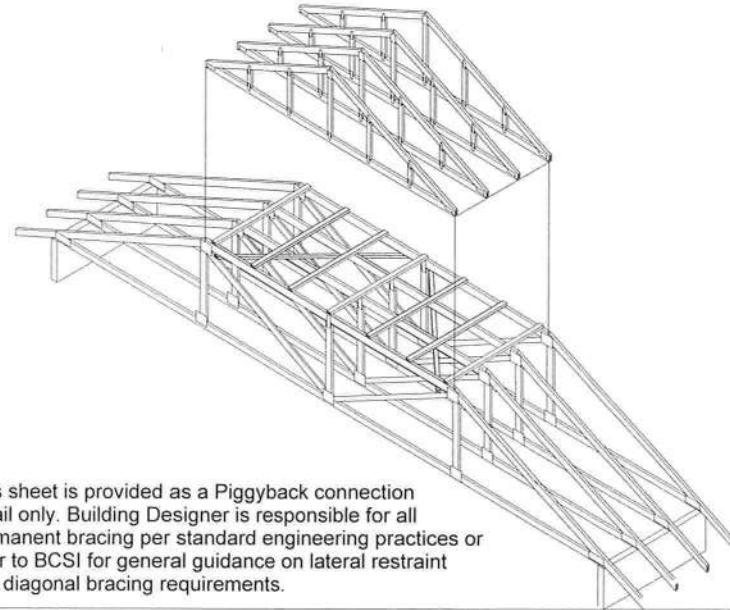

This sheet is provided as a Piggyback connection detail only. Building Designer is responsible for all permanent bracing per standard engineering practices or refer to BCSI for general guidance on lateral restraint and diagonal bracing requirements.

VERTICAL WEB TO EXTEND THROUGH BOTTOM CHORD OF PIGGYBACK

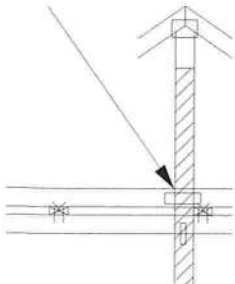

FOR LARGE CONCENTRATED LOADS APPLIED TO CAP TRUSS REQUIRING A VERTICAL WEB:

- 1) VERTICAL WEBS OF PIGGYBACK AND BASE TRUSS MUST MATCH IN SIZE, GRADE, AND MUST LINE UP AS SHOWN IN DETAIL.
- 2) ATTACH 2 x $\frac{1}{2}$ " x 4'-0" SCAB TO EACH FACE OF TRUSS ASSEMBLY WITH 2 ROWS OF 10d (0.131" X 3") NAILS SPACED 4" O.C. FROM EACH FACE. (SIZE AND GRADE TO MATCH VERTICAL WEBS OF PIGGYBACK AND BASE TRUSS.) (MINIMUM 2X4)
- 3) THIS CONNECTION IS ONLY VALID FOR A MAXIMUM CONCENTRATED LOAD OF 4000 LBS (@1.15). REVIEW BY A QUALIFIED ENGINEER IS REQUIRED FOR LOADS GREATER THAN 4000 LBS.
- 4) FOR PIGGYBACK TRUSSES CARRYING GIRDER LOADS, NUMBER OF PLYS OF PIGGYBACK TRUSS TO MATCH BASE TRUSS.
- 5) CONCENTRATED LOAD MUST BE APPLIED TO BOTH THE PIGGYBACK AND THE BASE TRUSS DESIGN.

This item has been electronically signed and sealed by O'Regan, Philip, P using a Digital Signature. Printed copies of this document are not considered signed and sealed and the signature must be verified on any electronic copies.

Philip J. O'Regan PE No. 58126
MiTek USA, Inc. FL Cert 6634
6904 Parke East Blvd. Tampa FL 33610
Date:

April 2, 2022

WARNING - Verify design parameters and READ NOTES ON THIS AND INCLUDED MITEK REFERENCE PAGE MII-7473 rev. 5/19/2020 BEFORE USE.

Design valid for use only with MiTek® connectors. This design is based only upon parameters shown, and is for an individual building component, not a truss system. Before use, the building designer must verify the applicability of design parameters and properly incorporate this design into the overall building design. Bracing indicated is to prevent buckling of individual truss web and/or chord members only. Additional temporary and permanent bracing is always required for stability and to prevent collapse with possible personal injury and property damage. For general guidance regarding the fabrication, storage, delivery, erection and bracing of trusses and truss systems, see **ANSI/TPI1 Quality Criteria, DSB-89 and BCSI Building Component Safety Information** available from Truss Plate Institute, 2670 Crain Highway, Suite 203 Waldorf, MD 20601



6904 Parke East Blvd.
Tampa, FL 33610

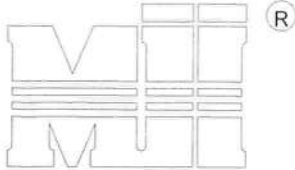

MiTek USA, Inc.

MAXIMUM WIND SPEED = REFER TO NOTES D AND OR E
 MAX MEAN ROOF HEIGHT = 30 FEET
 MAX TRUSS SPACING = 24" O.C.
 CATEGORY II BUILDING
 EXPOSURE B or C
 ENCLOSED BUILDING
 LOADING = 5 PSF TCDL MINIMUM
 ASCE 7-10, ASCE 7-16
 DURATION OF LOAD INCREASE : 1.60

DETAIL IS NOT APPLICABLE FOR TRUSSES TRANSFERRING DRAG LOADS (SHEAR TRUSSES). ADDITIONAL CONSIDERATIONS BY BUILDING ENGINEER/DESIGNER ARE REQUIRED.

- A - PIGGYBACK TRUSS, REFER TO MITEK TRUSS DESIGN DRAWING. SHALL BE CONNECTED TO EACH PURLIN WITH (2) 0(0.131" X 3.5") TOE-NAILED.
- B - BASE TRUSS, REFER TO MITEK TRUSS DESIGN DRAWING.
- C - PURLINS AT EACH BASE TRUSS JOINT AND A MAXIMUM 24" O.C. UNLESS SPECIFIED CLOSER ON MITEK TRUSS DESIGN DRAWING. CONNECT TO BASE TRUSS WITH (2) (0.131" X 3.5") NAILS EACH.
- D - 2 X $\frac{1}{2}$ " X 4'-0" SCAB, SIZE TO MATCH TOP CHORD OF PIGGYBACK TRUSS, MIN GRADE #2, ATTACHED TO ONE FACE, CENTERED ON INTERSECTION, WITH (2) ROWS OF (0.131" X 3") NAILS @ 4" O.C. SCAB MAY BE OMITTED PROVIDED THE TOP CHORD SHEATHING IS CONTINUOUS OVER INTERSECTION AT LEAST 1 FT. IN BOTH DIRECTIONS AND:
 - 1. WIND SPEED OF 115 MPH OR LESS FOR ANY PIGGYBACK SPAN, OR
 - 2. WIND SPEED OF 116 MPH TO 180 MPH WITH A MAXIMUM PIGGYBACK SPAN OF 12 ft.
- E - FOR WIND SPEED IN THE RANGE 116 MPH - 180 MPH ADD 9" x 9" x 1/2" PLYWOOD (or 7/16" OSB) GUSSET EACH SIDE AT 48" O.C. OR LESS. ATTACH WITH 3 - 6d (0.113" X 2") NAILS INTO EACH CHORD FROM EACH SIDE (TOTAL - 12 NAILS)

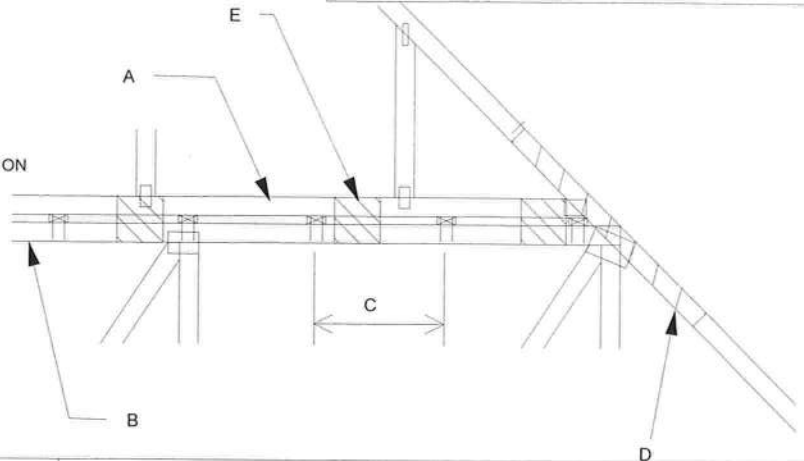

WHEN NO GAP BETWEEN PIGGYBACK AND BASE TRUSS EXISTS:

REPLACE TOE NAILING OF PIGGYBACK TRUSS TO PURLINS WITH PLYWOOD GUSSETS AS SHOWN, AND INSTALL PURLINS TO BOTTOM EDGE OF BASE TRUSS TOP CHORD AT SPECIFIED SPACING SHOWN ON BASE TRUSS MITEK DESIGN DRAWING.

SCAB CONNECTION PER NOTE D ABOVE

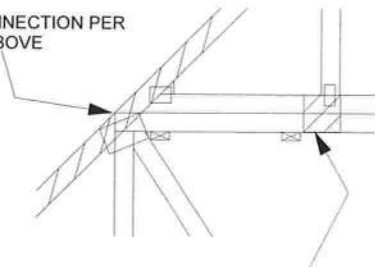

7" x 7" x 1/2" PLYWOOD (or 7/16" OSB) GUSSET EACH SIDE AT 24" O.C. ATTACH WITH 3 - 6d (0.113" X 2") NAILS INTO EACH CHORD FROM EACH SIDE (TOTAL - 12 NAILS)

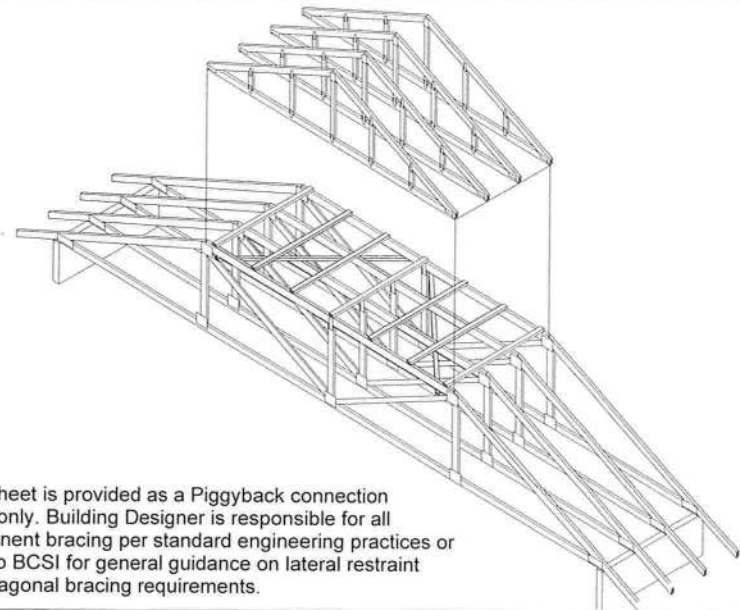

This sheet is provided as a Piggyback connection detail only. Building Designer is responsible for all permanent bracing per standard engineering practices or refer to BCSI for general guidance on lateral restraint and diagonal bracing requirements.

VERTICAL WEB TO EXTEND THROUGH BOTTOM CHORD OF PIGGYBACK

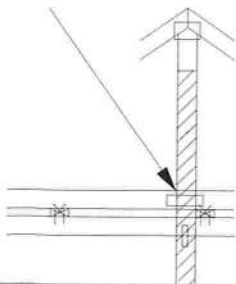

FOR LARGE CONCENTRATED LOADS APPLIED TO CAP TRUSS REQUIRING A VERTICAL WEB:

- 1) VERTICAL WEBS OF PIGGYBACK AND BASE TRUSS MUST MATCH IN SIZE, GRADE, AND MUST LINE UP AS SHOWN IN DETAIL.
- 2) ATTACH 2 x $\frac{1}{2}$ " X 4'-0" SCAB TO EACH FACE OF TRUSS ASSEMBLY WITH 2 ROWS OF 10d (0.131" X 3") NAILS SPACED 4" O.C. FROM EACH FACE. (SIZE AND GRADE TO MATCH VERTICAL WEBS OF PIGGYBACK AND BASE TRUSS.) (MINIMUM 2X4)
- 3) THIS CONNECTION IS ONLY VALID FOR A MAXIMUM CONCENTRATED LOAD OF 4000 LBS (@1.15). REVIEW BY A QUALIFIED ENGINEER IS REQUIRED FOR LOADS GREATER THAN 4000 LBS.
- 4) FOR PIGGYBACK TRUSSES CARRYING GIRDER LOADS, NUMBER OF PLYS OF PIGGYBACK TRUSS TO MATCH BASE TRUSS.
- 5) CONCENTRATED LOAD MUST BE APPLIED TO BOTH THE PIGGYBACK AND THE BASE TRUSS DESIGN.

This item has been electronically signed and sealed by O'Regan, Philip, PE using a Digital Signature. Printed copies of this document are not considered signed and sealed and the signature must be verified on any electronic copies.

Philip J. O'Regan PE No.58126
 MiTek USA, Inc. FL Cert 6634
 6904 Parke East Blvd. Tampa FL 33610
 Date:

April 2, 2021

WARNING - Verify design parameters and READ NOTES ON THIS AND INCLUDED MITEK REFERENCE PAGE MII-7473 rev. 5/19/2020 BEFORE USE
 Design valid for use only with MiTek® connectors. This design is based only upon parameters shown, and is for an individual building component, not a truss system. Before use, the building designer must verify the applicability of design parameters and properly incorporate this design into the overall building design. Bracing indicated is to prevent buckling of individual truss web and/or chord members only. Additional temporary and permanent bracing is always required for stability and to prevent collapse with possible personal injury and property damage. For general guidance regarding the fabrication, storage, delivery, erection and bracing of trusses and truss systems, see **ANSI/TPI1 Quality Criteria, DSB-89 and BCSI Building Component Safety Information** available from Truss Plate Institute, 2670 Crain Highway, Suite 203 Waldorf, MD 20601



6904 Parke East Blvd.
 Tampa, FL 33610

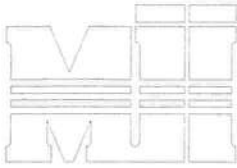

MiTek USA, Inc.

R

TOTAL NUMBER OF NAILS EACH SIDE OF BREAK *		X INCHES	MAXIMUM FORCE (lbs) 15% LOAD DURATION							
			SP		DF		SPF		HF	
2x4	2x6		2x4	2x6	2x4	2x6	2x4	2x6	2x4	2x6
20	30	24"	1706	2559	1561	2342	1320	1980	1352	2028
26	39	30"	2194	3291	2007	3011	1697	2546	1738	2608
32	48	36"	2681	4022	2454	3681	2074	3111	2125	3187
38	57	42"	3169	4754	2900	4350	2451	3677	2511	3767
44	66	48"	3657	5485	3346	5019	2829	4243	2898	4347

* DIVIDE EQUALLY FRONT AND BACK

ATTACH 2x_ SCAB OF THE SAME SIZE AND GRADE AS THE BROKEN MEMBER TO EACH FACE OF THE TRUSS (CENTER ON BREAK OR SPLICE) WITH 10d (0.131" X 3") NAILS (TWO ROWS FOR 2x4, THREE ROWS FOR 2x6) SPACED 4" O.C. AS SHOWN. STAGGER NAIL SPACING FROM FRONT FACE AND BACK FACE FOR A NET 0-2-0 O.C. SPACING IN THE MAIN MEMBER. USE A MIN. 0-3-0 MEMBER END DISTANCE.

THE LENGTH OF THE BREAK (C) SHALL NOT EXCEED 12". (C=PLATE LENGTH FOR SPLICE REPAIRS)
THE MINIMUM OVERALL SCAB LENGTH REQUIRED (L) IS CALCULATED AS FOLLOWS:
 $L = (2) X + C$

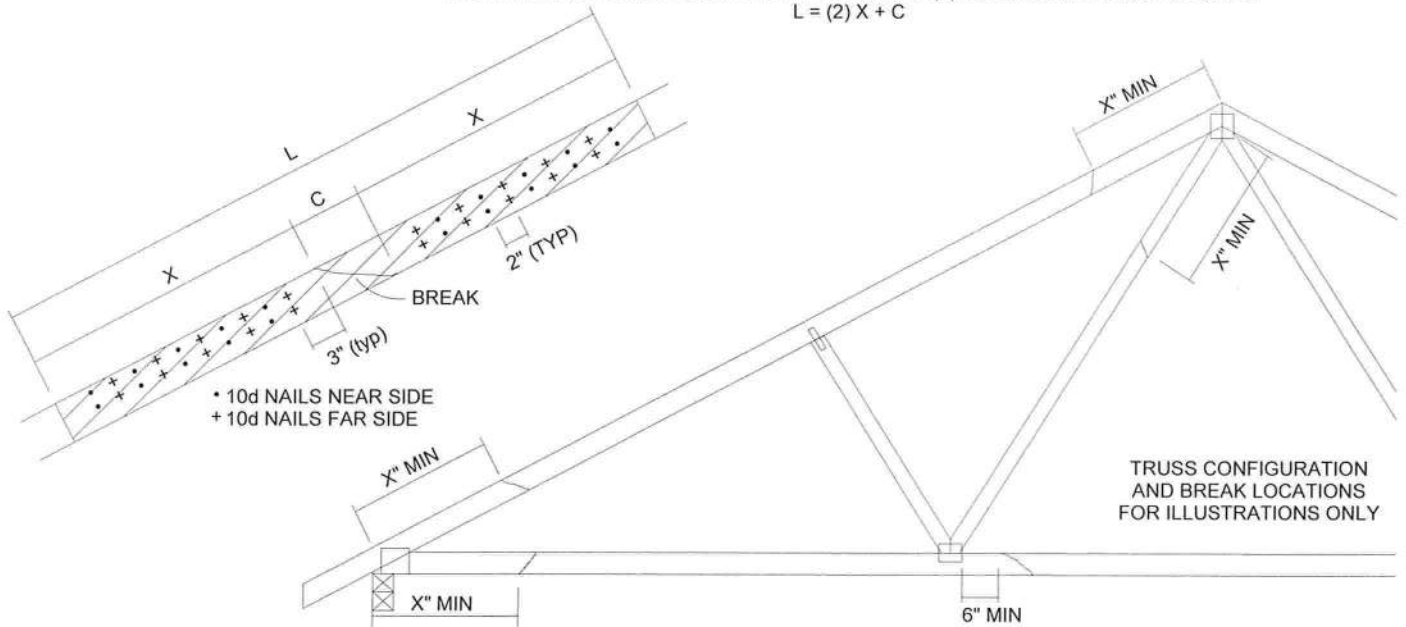

THE LOCATION OF THE BREAK MUST BE GREATER THAN OR EQUAL TO THE REQUIRED X DIMENSION FROM ANY PERIMETER BREAK OR HEEL JOINT AND A MINIMUM OF 6" FROM ANY INTERIOR JOINT (SEE SKETCH ABOVE)

DO NOT USE REPAIR FOR JOINT SPLICES

NOTES:

1. THIS REPAIR DETAIL IS TO BE USED ONLY FOR THE APPLICATION SHOWN. THIS REPAIR DOES NOT IMPLY THAT THE REMAINING PORTION OF THE TRUSS IS UNDAMAGED. THE ENTIRE TRUSS SHALL BE INSPECTED TO VERIFY THAT NO FURTHER REPAIRS ARE REQUIRED. WHEN THE REQUIRED REPAIRS ARE PROPERLY APPLIED, THE TRUSS WILL BE CAPABLE OF SUPPORTING THE LOADS INDICATED.
2. ALL MEMBERS MUST BE RETURNED TO THEIR ORIGINAL POSITIONS BEFORE APPLYING REPAIR AND HELD IN PLACE DURING APPLICATION OF REPAIR.
3. THE END DISTANCE, EDGE DISTANCE AND SPACING OF NAILS SHALL BE SUCH AS TO AVOID UNUSUAL SPLITTING OF THE WOOD.
4. WHEN NAILING THE SCABS, THE USE OF A BACKUP WEIGHT IS RECOMMENDED TO AVOID LOOSENING OF THE CONNECTOR PLATES AT THE JOINTS OR SPLICES.
5. THIS REPAIR IS TO BE USED FOR SINGLE PLY TRUSSES IN THE 2x_ ORIENTATION ONLY.
6. THIS REPAIR IS LIMITED TO TRUSSES WITH NO MORE THAN THREE BROKEN MEMBERS.

This item has been electronically signed and sealed by O'Regan, Philip, P using a Digital Signature. Printed copies of this document are not considered signed and sealed and the signature must be verified on any electronic copies.

Philip J. O'Regan PE No.58126
MiTek USA, Inc. FL Cert 6634
6904 Parke East Blvd. Tampa FL 33610
Date:

April 2,202

WARNING - Verify design parameters and READ NOTES ON THIS AND INCLUDED MITEK REFERENCE PAGE MII-7473 rev. 5/19/2020 BEFORE USE.

Design valid for use only with MiTek® connectors. This design is based only upon parameters shown, and is for an individual building component, not a truss system. Before use, the building designer must verify the applicability of design parameters and properly incorporate this design into the overall building design. Bracing indicated is to prevent buckling of individual truss web and/or chord members only. Additional temporary and permanent bracing is always required for stability and to prevent collapse with possible personal injury and property damage. For general guidance regarding the fabrication, storage, delivery, erection and bracing of trusses and truss systems, see ANSITPI1 Quality Criteria, DSB-89 and BCSI Building Component Safety Information available from Truss Plate Institute, 2670 Crain Highway, Suite 203 Waldorf, MD 20601



6904 Parke East Blvd.
Tampa, FL 36610

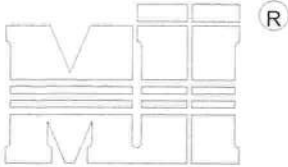

MiTek USA, Inc.

NOTES:

- TOE-NAILS SHALL BE DRIVEN AT AN ANGLE OF 45 DEGREES WITH THE MEMBER AND MUST HAVE FULL WOOD SUPPORT. (NAIL MUST BE DRIVEN THROUGH AND EXIT AT THE BACK CORNER OF THE MEMBER END AS SHOWN).
- THE END DISTANCE, EDGE DISTANCE, AND SPACING OF NAILS SHALL BE SUCH AS TO AVOID UNUSUAL SPLITTING OF THE WOOD.
- ALLOWABLE VALUE SHALL BE THE LESSER VALUE OF THE TWO SPECIES FOR MEMBERS OF DIFFERENT SPECIES.

THIS DETAIL APPLICABLE TO THE THREE END DETAILS SHOWN BELOW

VIEWS SHOWN ARE FOR ILLUSTRATION PURPOSES ONLY

TOE-NAIL SINGLE SHEAR VALUES PER NDS 2018 (lb/nail)

	DIAM.	SP	DF	HF	SPF	SPF-S
3.5" LONG	.131	88.0	80.6	69.9	68.4	59.7
	.135	93.5	85.6	74.2	72.6	63.4
	.162	108.8	99.6	86.4	84.5	73.8
3.25" LONG	.128	74.2	67.9	58.9	57.6	50.3
	.131	75.9	69.5	60.3	59.0	51.1
	.148	81.4	74.5	64.6	63.2	52.5

VALUES SHOWN ARE CAPACITY PER TOE-NAIL. APPLICABLE DURATION OF LOAD INCREASES MAY BE APPLIED.

EXAMPLE:
(3) - 16d (0.162" X 3.5") NAILS WITH SPF SPECIES BOTTOM CHORD

For load duration increase of 1.15:
3 (nails) X 84.5 (lb/nail) X 1.15 (DOL) = 291.5 lb Maximum Capacity

SIDE VIEW
(2x3)
2 NAILS

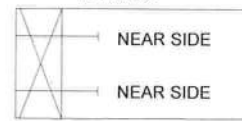

SIDE VIEW
(2x4)
3 NAILS

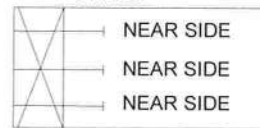

SIDE VIEW
(2x6)
4 NAILS

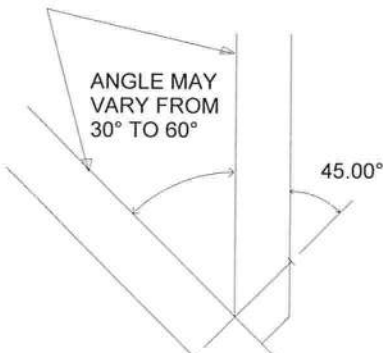
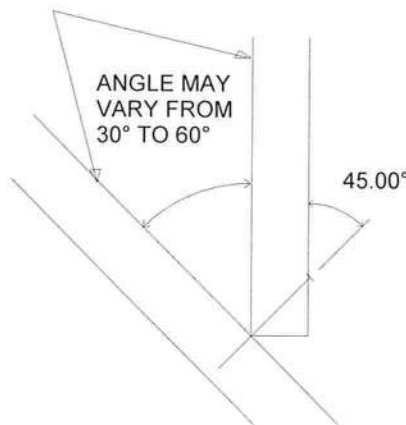
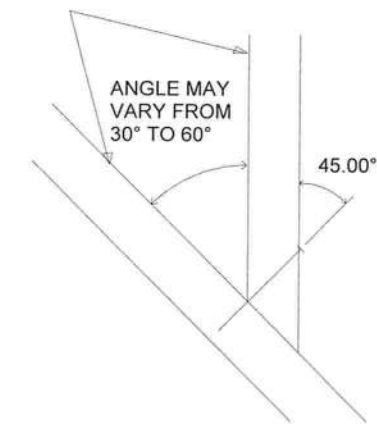
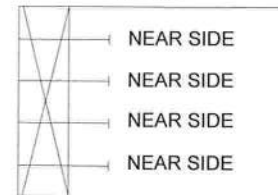

This item has been electronically signed and sealed by O'Regan, Philip, PE using a Digital Signature. Printed copies of this document are not considered signed and sealed and the signature must be verified on any electronic copies.

Philip J. O'Regan PE No.58126
MiTek USA, Inc. FL Cert 6634
6904 Parke East Blvd. Tampa FL 33610
Date:

April 2,2021

WARNING - Verify design parameters and READ NOTES ON THIS AND INCLUDED MITER REFERENCE PAGE MII-7473 rev. 5/19/2020 BEFORE USE

Design valid for use only with MiTek® connectors. This design is based only upon parameters shown, and is for an individual building component, not a truss system. Before use, the building designer must verify the applicability of design parameters and properly incorporate this design into the overall building design. Bracing indicated is to prevent buckling of individual truss web and/or chord members only. Additional temporary and permanent bracing is always required for stability and to prevent collapse with possible personal injury and property damage. For general guidance regarding the fabrication, storage, delivery, erection and bracing of trusses and truss systems, see **ANSI/TPI1 Quality Criteria, DSB-89 and BCSI Building Component**

Safety Information available from Truss Plate Institute, 2670 Crain Highway, Suite 203 Waldorf, MD 20601



6904 Parke East Blvd.
Tampa, FL 36610

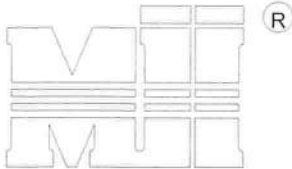

MiTek USA, Inc.

GENERAL SPECIFICATIONS

1. NAIL SIZE 10d (0.131" X 3")
2. WOOD SCREW = 3" WS3 USP OR EQUIVALENT
DO NOT USE DRYWALL OR DECKING TYPE SCREW
3. INSTALL VALLEY TRUSSES (24" O.C. MAXIMUM) AND SECURE PER DETAIL A
4. BRACE VALLEY WEBS IN ACCORDANCE WITH THE INDIVIDUAL DESIGN DRAWINGS.
5. BASE TRUSS SHALL BE DESIGNED WITH A PURLIN SPACING EQUIVANT TO THE RAKE DIMENSION OF THE VALLEY TRUSS SPACING.
6. NAILING DONE PER NDS - 01
7. VALLEY STUD SPACING NOT TO EXCEED 48" O.C.

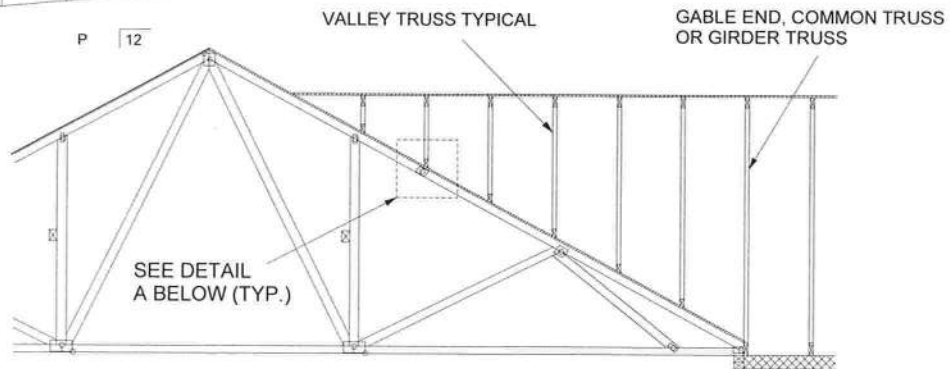
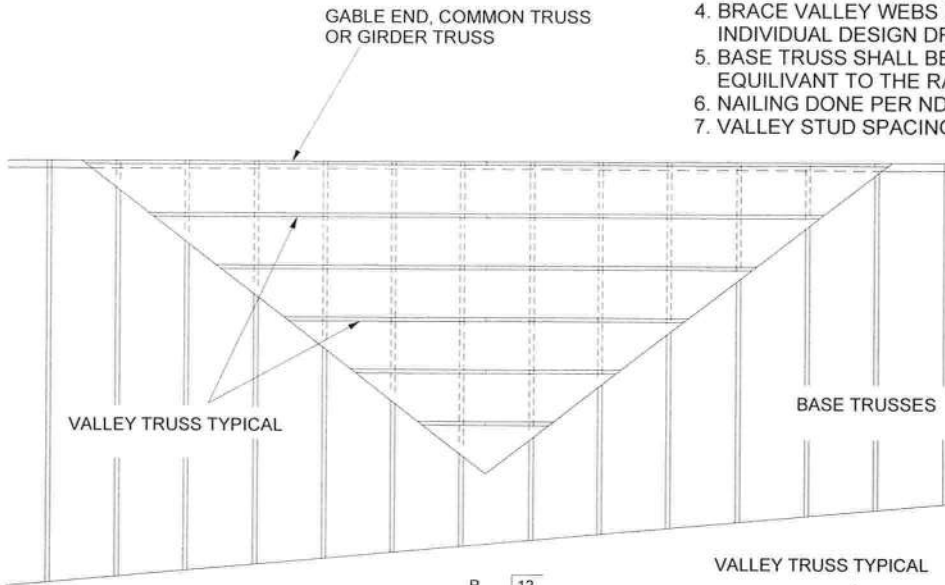

SECURE VALLEY TRUSS
W/ ONE ROW OF 10d
NAILS 6" O.C.

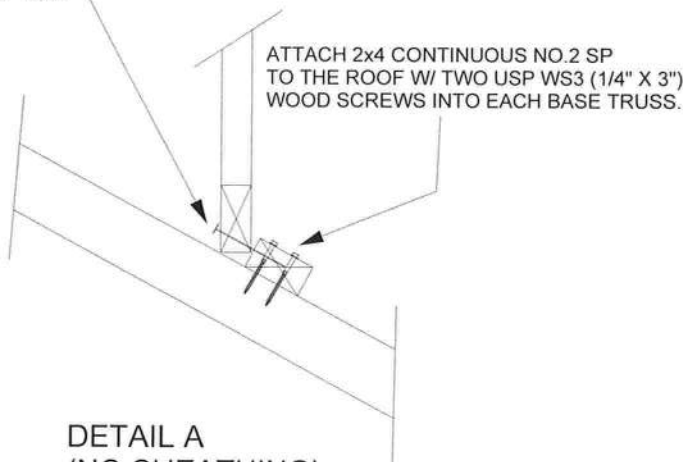

DETAIL A
(NO SHEATHING)
N.T.S.

WIND DESIGN PER ASCE 7-98, ASCE 7-02, ASCE 7-05 146 MPH
WIND DESIGN PER ASCE 7-10, ASCE 7-16 160 MPH
MAX MEAN ROOF HEIGHT = 30 FEET
ROOF PITCH = MINIMUM 3/12 MAXIMUM 6/12
CATEGORY II BUILDING
EXPOSURE C
WIND DURATION OF LOAD INCREASE : 1.60
MAX TOP CHORD TOTAL LOAD = 50 PSF
MAX SPACING = 24" O.C. (BASE AND VALLEY)
MINIMUM REDUCED DEAD LOAD OF 6 PSF
ON THE TRUSSES

This item has been electronically signed and sealed by O'Regan, Philip, P using a Digital Signature. Printed copies of this document are not considered signed and sealed and the signature must be verified on any electronic copies.

Philip J. O'Regan PE No.58126
MiTek USA, Inc. FL Cert 6634
6904 Parke East Blvd. Tampa FL 33610
Date:

April 2, 2022

WARNING - Verify design parameters and READ NOTES ON THIS AND INCLUDED MITEK REFERENCE PAGE MII-7473 rev. 5/19/2020 BEFORE USE.

Design valid for use only with MiTek® connectors. This design is based only upon parameters shown, and is for an individual building component, not a truss system. Before use, the building designer must verify the applicability of design parameters and properly incorporate this design into the overall building design. Bracing indicated is to prevent buckling of individual truss web and/or chord members only. Additional temporary and permanent bracing is always required for stability and to prevent collapse with possible personal injury and property damage. For general guidance regarding the fabrication, storage, delivery, erection and bracing of trusses and truss systems, see

ANSI/TPI1 Quality Criteria, DSB-89 and BCSI Building Component

Safety Information available from Truss Plate Institute, 2670 Crain Highway, Suite 203 Waldorf, MD 20601



6904 Parke East Blvd.
Tampa, FL 36610

MiTek USA, Inc.

GABLE END, COMMON TRUSS
OR GIRDER TRUSS

GENERAL SPECIFICATIONS

1. NAIL SIZE 10d (0.131" X 3")
2. WOOD SCREW = 4.5" WS45 USP OR EQUIVANT
3. INSTALL SHEATHING TO TOP CHORD OF BASE TRUSSES.
4. INSTALL VALLEY TRUSSES (24" O.C. MAXIMUM) AND SECURE TO BASE TRUSSES AS PER DETAIL A
5. BRACE VALLEY WEBS IN ACCORDANCE WITH THE INDIVIDUAL DESIGN DRAWINGS.
6. NAILING DONE PER NDS-01
7. VALLEY STUD SPACING NOT TO EXCEED 48" O.C.

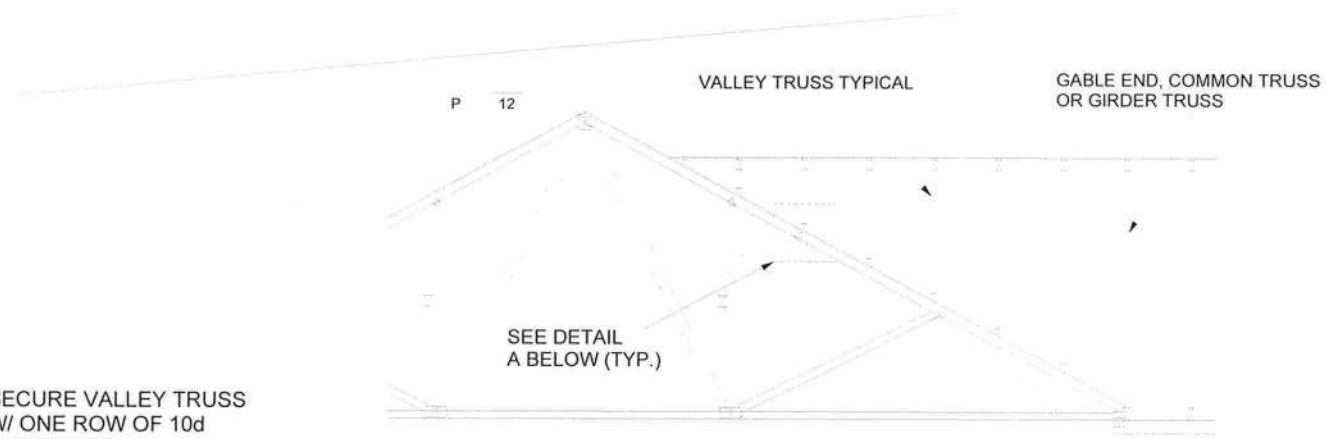
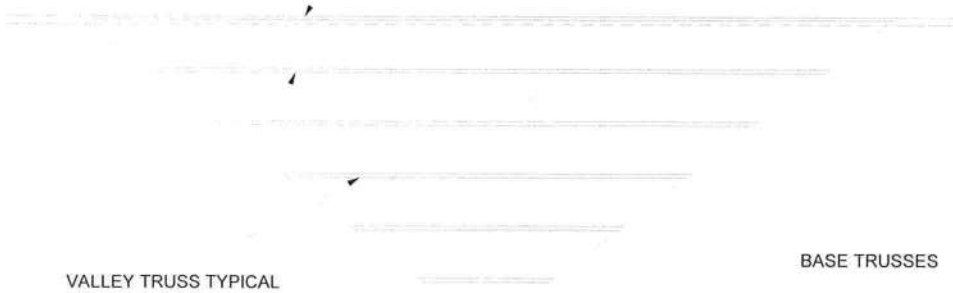

SECURE VALLEY TRUSS
W/ ONE ROW OF 10d
NAILS 6" O.C.

ATTACH 2x4 CONTINUOUS NO.2 SP
TO THE ROOF W/ TWO USP WS45 (1/4" X 4.5")
WOOD SCREWS INTO EACH BASE TRUSS.

WIND DESIGN PER ASCE 7-98, ASCE 7-02, ASCE 7-05 146 MPH
 WIND DESIGN PER ASCE 7-10, ASCE 7-16 160 MPH
 MAX MEAN ROOF HEIGHT = 30 FEET
 ROOF PITCH = MINIMUM 3/12 MAXIMUM 6/12
 CATEGORY II BUILDING
 EXPOSURE C
 WIND DURATION OF LOAD INCREASE : 1.60
 MAX TOP CHORD TOTAL LOAD = 50 PSF
 MAX SPACING = 24" O.C. (BASE AND VALLEY)
 MINIMUM REDUCED DEAD LOAD OF 6 PSF
 ON THE TRUSSES

This item has been electronically signed and sealed by O'Regan, Philip, P using a Digital Signature. Printed copies of this document are not considered signed and sealed and the signature must be verified on any electronic copies.

Philip J. O'Regan PE No.58126
 MiTek USA, Inc. FL Cert 6634
 6904 Parke East Blvd. Tampa FL 33610
 Date:

April 2,202

WARNING - Verify design parameters and READ NOTES ON THIS AND INCLUDED MITEK REFERENCE PAGE MII-7473 rev 5/19/2020 BEFORE USE.

Design valid for use only with MiTek® connectors. This design is based only upon parameters shown, and is for an individual building component, not a truss system. Before use, the building designer must verify the applicability of design parameters and properly incorporate this design into the overall building design. Bracing indicated is to prevent buckling of individual truss web and/or chord members only. Additional temporary and permanent bracing is always required for stability and to prevent collapse with possible personal injury and property damage. For general guidance regarding the fabrication, storage, delivery, erection and bracing of trusses and truss systems, see **ANSI/TPI1 Quality Criteria, DSB-89 and BCSI Building Component Safety Information** available from Truss Plate Institute, 2670 Crain Highway, Suite 203 Waldorf, MD 20601



6904 Parke East Blvd.
 Tampa, FL 36610

R

GENERAL SPECIFICATIONS

1. NAIL SIZE 16d (0.131" X 3.5")
2. INSTALL VALLEY TRUSSES (24" O.C. MAXIMUM) AND SECURE PER DETAIL A
3. BRACE VALLEY WEBS IN ACCORDANCE WITH THE INDIVIDUAL DESIGN DRAWINGS.
4. BASE TRUSS SHALL BE DESIGNED WITH A PURLIN SPACING EQUIVARIANT TO THE RAKE DIMENSION OF THE VALLEY TRUSS SPACING.
5. NAILING DONE PER NDS - 01
6. VALLEY STUD SPACING NOT TO EXCEED 48" O.C.
7. ALL LUMBER SPECIES TO BE SP.

MiTek USA, Inc.

GABLE END, COMMON TRUSS
OR GIRDER TRUSS

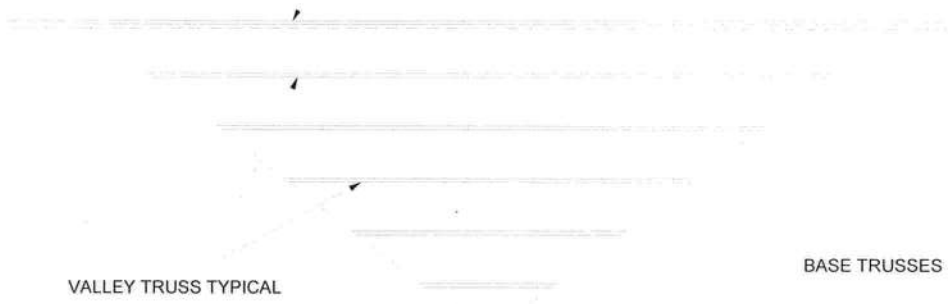

VALLEY TRUSS TYPICAL

BASE TRUSSES

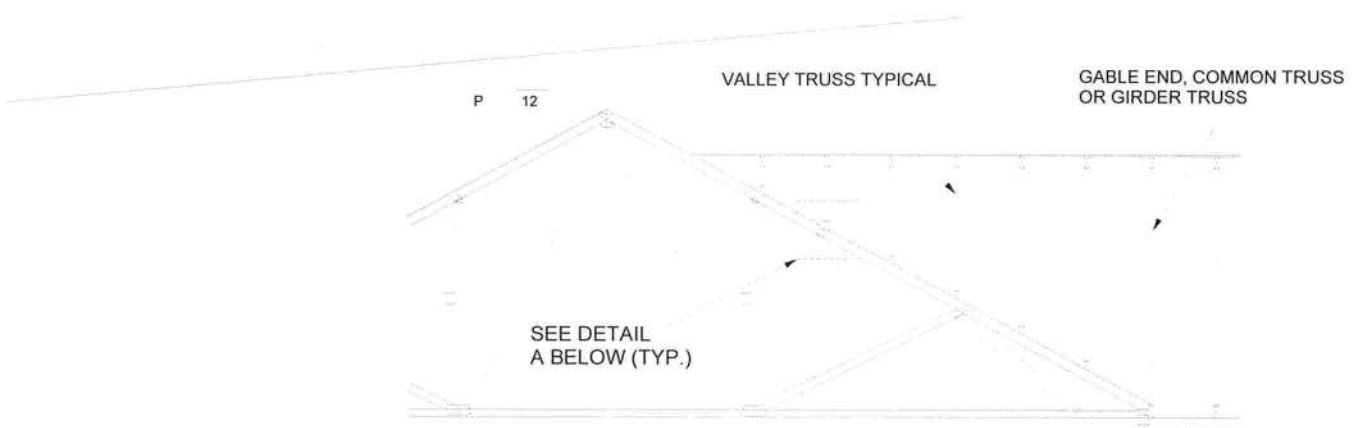

VALLEY TRUSS TYPICAL

GABLE END, COMMON TRUSS
OR GIRDER TRUSS

P 12

SEE DETAIL
A BELOW (TYP.)

SECURE VALLEY TRUSS
W/ ONE ROW OF 16d
NAILS 6" O.C.

ATTACH 2x4 CONTINUOUS NO.2 SP
TO THE ROOF W/ TWO 16d NAILS
INTO EACH BASE TRUSS.

WIND DESIGN PER ASCE 7-98, ASCE 7-02, ASCE 7-05 120 MPH
 WIND DESIGN PER ASCE 7-10, ASCE 7-16 150 MPH
 MAX MEAN ROOF HEIGHT = 30 FEET
 ROOF PITCH = MINIMUM 3/12 MAXIMUM 10/12
 CATEGORY II BUILDING
 EXPOSURE C OR B
 WIND DURATION OF LOAD INCREASE : 1.60
 MAX TOP CHORD TOTAL LOAD = 60 PSF
 MAX SPACING = 24" O.C. (BASE AND VALLEY)
 MINIMUM REDUCED DEAD LOAD OF 4.2 PSF
 ON THE TRUSSES

This item has been electronically signed and sealed by O'Regan, Philip, P using a Digital Signature. Printed copies of this document are not considered signed and sealed and the signature must be verified on any electronic copies.

Philip J. O'Regan PE No. 58126
 MiTek USA, Inc. FL Cert 6634
 6904 Parke East Blvd. Tampa FL 33610
 Date:

April 2, 202

DETAIL A
(MAXIMUM 1" SHEATHING)
N.T.S.

WARNING - Verify design parameters and READ NOTES ON THIS AND INCLUDED MITEK REFERENCE PAGE MII-7473 rev 5/19/2020 BEFORE USE.

Design valid for use only with MiTek® connectors. This design is based only upon parameters shown, and is for an individual building component, not a truss system. Before use, the building designer must verify the applicability of design parameters and properly incorporate this design into the overall building design. Bracing indicated is to prevent buckling of individual truss web and/or chord members only. Additional temporary and permanent bracing is always required for stability and to prevent collapse with possible personal injury and property damage. For general guidance regarding the fabrication, storage, delivery, erection and bracing of trusses and truss systems, see **ANSI/TPI1 Quality Criteria, DSB-89 and BCSI Building Component Safety Information** available from Truss Plate Institute, 2670 Crain Highway, Suite 203 Waldorf, MD 20601



6904 Parke East Blvd.
 Tampa, FL 36510

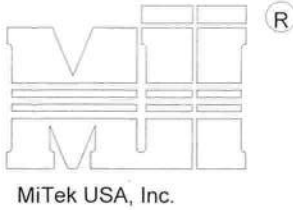

GENERAL SPECIFICATIONS

1. NAIL SIZE 16d (0.131" X 3.5")
2. INSTALL VALLEY TRUSSES (24" O.C. MAXIMUM) AND SECURE PER DETAIL A
3. BRACE VALLEY WEBS IN ACCORDANCE WITH THE INDIVIDUAL DESIGN DRAWINGS.
4. BASE TRUSS SHALL BE DESIGNED WITH A PURLIN SPACING EQUIVARIANT TO THE RAKE DIMENSION OF THE VALLEY TRUSS SPACING.
5. NAILING DONE PER NDS - 01
6. VALLEY STUD SPACING NOT TO EXCEED 48" O.C.
7. ALL LUMBER SPECIES TO BE SP.

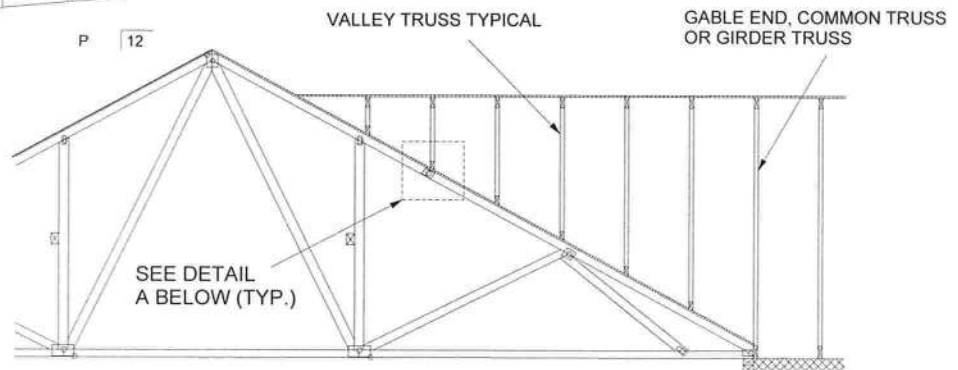
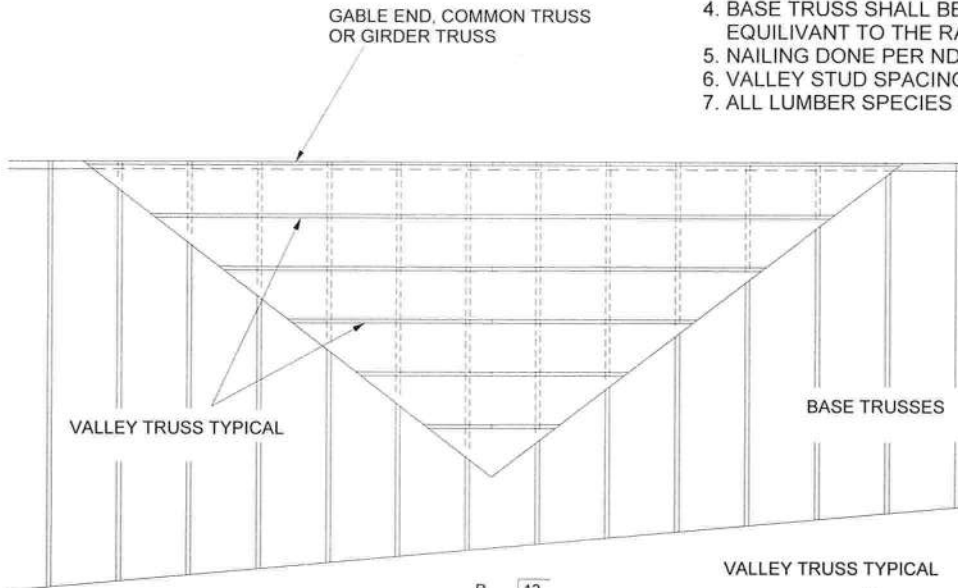

SECURE VALLEY TRUSS W/ ONE ROW OF 16d NAILS 6" O.C.

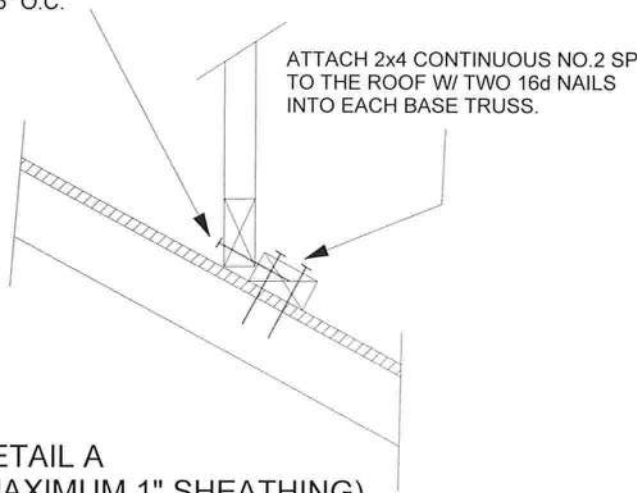

DETAIL A
(MAXIMUM 1" SHEATHING)
N.T.S.

WIND DESIGN PER ASCE 7-98, ASCE 7-02, ASCE 7-05 120 MPH
 WIND DESIGN PER ASCE 7-10, ASCE 7-16 150 MPH
 MAX MEAN ROOF HEIGHT = 30 FEET
 ROOF PITCH = MINIMUM 3/12 MAXIMUM 10/12
 CATEGORY II BUILDING
 EXPOSURE C OR B
 WIND DURATION OF LOAD INCREASE : 1.60
 MAX TOP CHORD TOTAL LOAD = 60 PSF
 MAX SPACING = 24" O.C. (BASE AND VALLEY)
 MINIMUM REDUCED DEAD LOAD OF 4.2 PSF ON THE TRUSSES

This item has been electronically signed and sealed by O'Regan, Philip, PI using a Digital Signature. Printed copies of this document are not considered signed and sealed and the signature must be verified on any electronic copies.

Philip J. O'Regan PE No.58126
 MiTek USA, Inc. FL Cert 6634
 6904 Parke East Blvd. Tampa FL 33610
 Date:

April 2, 2021

WARNING - Verify design parameters and READ NOTES ON THIS AND INCLUDED MITEK REFERENCE PAGE MII-7473 rev 5/19/2020 BEFORE USE.

Design valid for use only with MiTek® connectors. This design is based only upon parameters shown, and is for an individual building component, not a truss system. Before use, the building designer must verify the applicability of design parameters and properly incorporate this design into the overall building design. Bracing indicated is to prevent buckling of individual truss web and/or chord members only. Additional temporary and permanent bracing is always required for stability and to prevent collapse with possible personal injury and property damage. For general guidance regarding the fabrication, storage, delivery, erection and bracing of trusses and truss systems, see **ANSI/TPI1 Quality Criteria, DSB-89 and BCSI Building Component Safety Information** available from Truss Plate Institute, 2670 Crain Highway, Suite 203 Waldorf, MD 20601



6904 Parke East Blvd.
Tampa, FL 33610

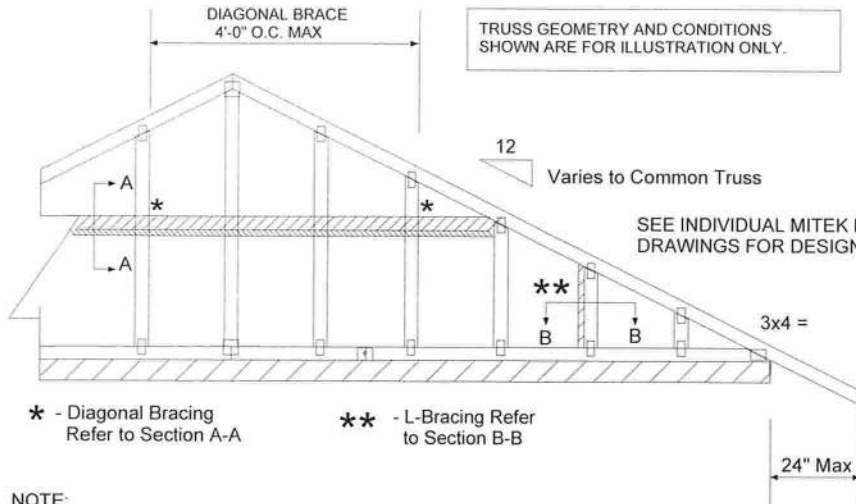
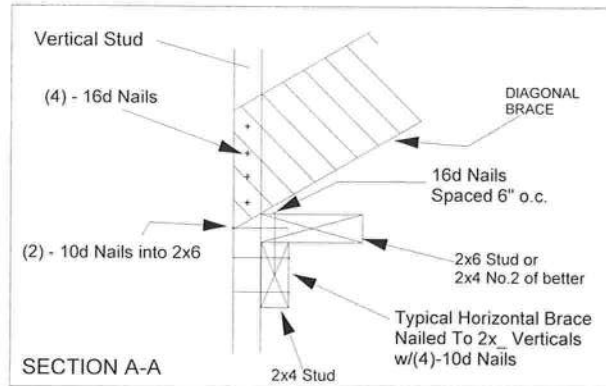
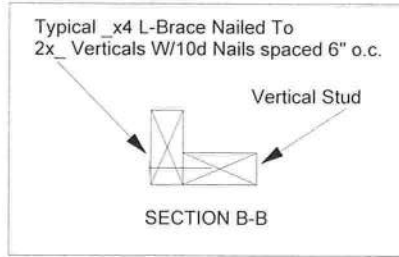

PROVIDE 2x4 BLOCKING BETWEEN THE FIRST TWO TRUSSES AS NOTED. TOENAIL BLOCKING TO TRUSSES WITH (2) - 10d NAILS AT EACH END. ATTACH DIAGONAL BRACE TO BLOCKING WITH (5) - 10d NAILS.

(4) - 8d (0.131" X 2.5") NAILS MINIMUM, PLYWOOD SHEATHING TO 2x4 STD SP BLOCK

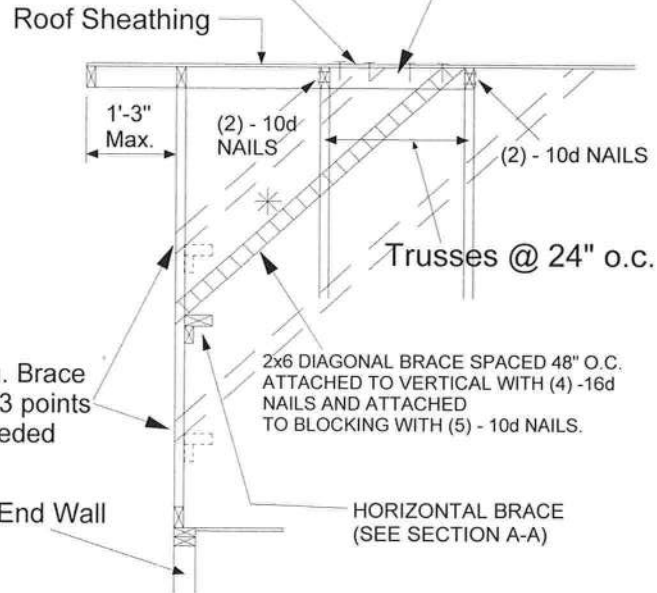

- NOTE:
1. MINIMUM GRADE OF #2 MATERIAL IN THE TOP AND BOTTOM CHORDS.
 2. CONNECTION BETWEEN BOTTOM CHORD OF GABLE END TRUSS AND WALL TO BE PROVIDED BY PROJECT ENGINEER OR ARCHITECT.
 3. BRACING SHOWN IS FOR INDIVIDUAL TRUSS ONLY. CONSULT BLDG. ARCHITECT OR ENGINEER FOR TEMPORARY AND PERMANENT BRACING OF ROOF SYSTEM.
 4. "L" BRACES SPECIFIED ARE TO BE FULL LENGTH. GRADES: 2x4 No 3/STUD SP OR BETTER WITH ONE ROW OF 10d NAILS SPACED 6" O.C.
 5. DIAGONAL BRACE TO BE APPROXIMATELY 45 DEGREES TO ROOF DIAPHRAM AT 4'-0" O.C.
 6. CONSTRUCT HORIZONTAL BRACE CONNECTING A 2x6 STUD AND A 2x4 STUD AS SHOWN WITH 16d NAILS SPACED 6" O.C. HORIZONTAL BRACE TO BE LOCATED AT THE MIDSPAN OF THE LONGEST STUD. ATTACH TO VERTICAL STUDS WITH (4) 10d NAILS THROUGH 2x4. (REFER TO SECTION A-A)
 7. GABLE STUD DEFLECTION MEETS OR EXCEEDS L/240.
 8. THIS DETAIL DOES NOT APPLY TO STRUCTURAL GABLES.
 9. DO NOT USE FLAT BOTTOM CHORD GABLES NEXT TO SCISSOR TYPE TRUSSES.
 10. NAILS DESIGNATED 10d ARE (0.131" X 3") AND NAILS DESIGNATED 16d ARE (0.131" X 3.5")

Minimum Stud Size Species and Grade	Stud Spacing	Without Brace	2x4 L-Brace	DIAGONAL BRACE	2 DIAGONAL BRACES AT 1/3 POINTS
		Maximum Stud Length			
2x4 SP No 3/Stud	12" O.C.	3-11-3	6-8-0	7-2-14	11-9-10
2x4 SP No 3/Stud	16" O.C.	3-6-14	5-9-5	7-1-13	10-8-11
2x4 SP No 3/Stud	24" O.C.	3-1-8	4-8-9	6-2-15	9-4-7

* Diagonal braces over 6'-3" require a 2x4 T-Brace attached to one edge. Diagonal braces over 12'-6" require 2x4 I-braces attached to both edges. Fasten T and I braces to narrow edge of web with 10d nails 8" o.c., with 3" minimum end distance. Brace must cover 90% of diagonal length.

This item has been electronically signed and sealed by O'Regan, Philip, PI using a Digital Signature. Printed copies of this document are not considered signed and sealed and the signature must be verified on any electronic copies.

Philip J. O'Regan PE No.58126
MiTek USA, Inc. FL Cert 6634
6904 Parke East Blvd. Tampa FL 33610
Date:

April 2, 2021

MAXIMUM WIND SPEED = 146 MPH
MAX MEAN ROOF HEIGHT = 30 FEET
CATEGORY II BUILDING
EXPOSURE B or C

ASCE 7-98, ASCE 7-02, ASCE 7-05

DURATION OF LOAD INCREASE 1.60

STUD DESIGN IS BASED ON COMPONENTS AND CLADDING.

CONNECTION OF BRACING IS BASED ON MWFRS

Design valid for use only with MiTek® connectors. This design is based only upon parameters shown, and is for an individual building component, not a truss system. Before use, the building designer must verify the applicability of design parameters and properly incorporate this design into the overall building design. Bracing indicated is to prevent buckling of individual truss web and/or chord members only. Additional temporary and permanent bracing is always required for stability and to prevent collapse with possible personal injury and property damage. For general guidance regarding the fabrication, storage, delivery, erection and bracing of trusses and truss systems, see ANSITPI1 Quality Criteria, DSB-89 and BCSI Building Component Safety Information available from Truss Plate Institute, 2670 Crain Highway, Suite 203 Waldorf, MD 20601



6904 Parke East Blvd.
Tampa, FL 33610

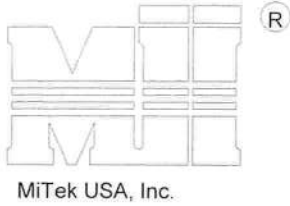

ALTERNATE DIAGONAL BRACING TO THE BOTTOM CHORD

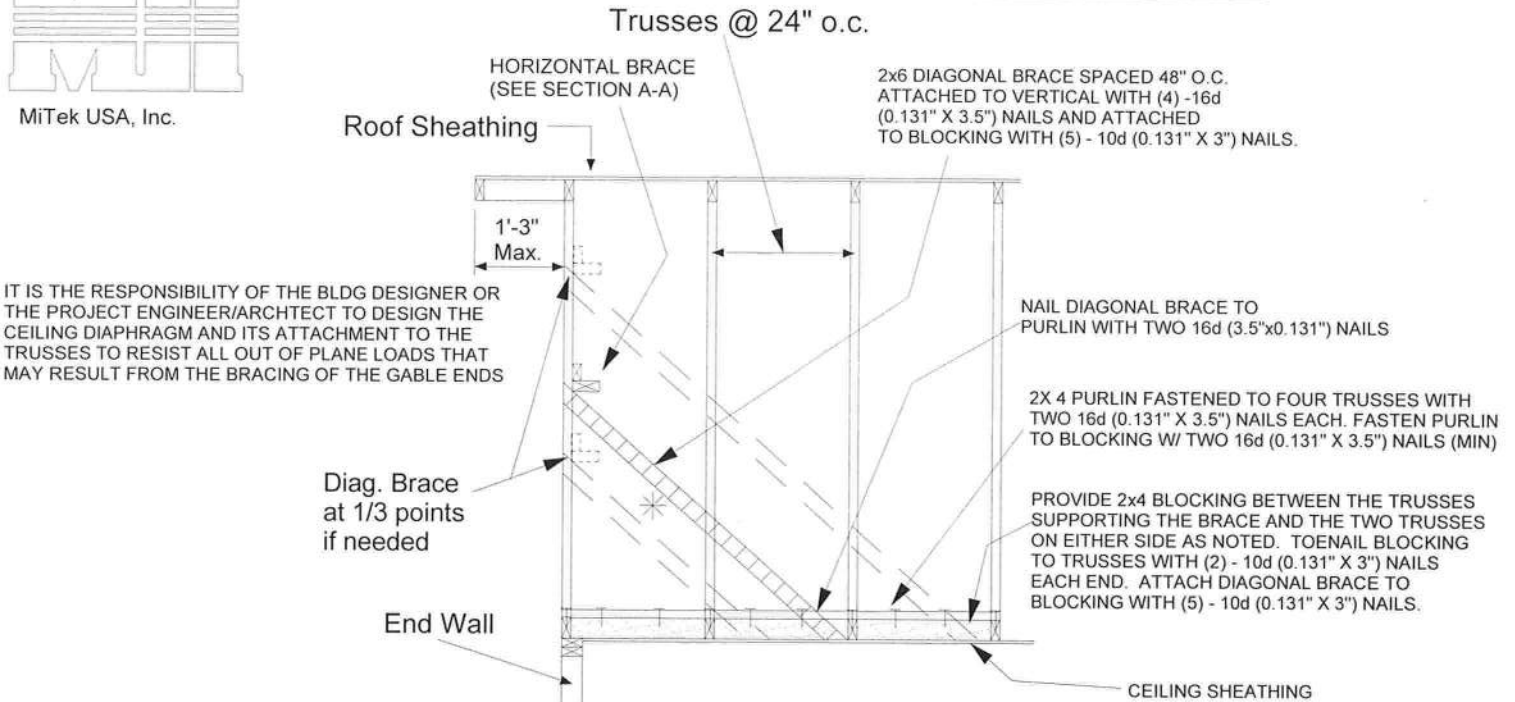

BRACING REQUIREMENTS FOR STRUCTURAL GABLE TRUSSES

STRUCTURAL GABLE TRUSSES MAY BE BRACED AS NOTED:

METHOD 1 : ATTACH A MATCHING GABLE TRUSS TO THE INSIDE FACE OF THE STRUCTURAL GABLE AND FASTEN PER THE FOLLOWING NAILING SCHEDULE.

METHOD 2 : ATTACH 2X _ SCABS TO THE FACE OF EACH VERTICAL MEMBER ON THE STRUCTURAL GABLE PER THE FOLLOWING NAILING SCHEDULE. SCABS ARE TO BE OF THE SAME SIZE, GRADE AND SPECIES AS THE TRUSS VERTICALS

NAILING SCHEDULE:

- FOR WIND SPEEDS 120 MPH (ASCE 7-98, 02, 05), 150 MPH (ASCE 7-10, 16) OR LESS, NAIL ALL MEMBERS WITH ONE ROW OF 10d (0.131" X 3") NAILS SPACED 6" O.C.
- FOR WIND SPEEDS 120-150 MPH (ASCE 7-98, 02, 05), 150-190 MPH (ASCE 7-10, 16) NAIL ALL MEMBERS WITH TWO ROWS OF 10d (0.131" X 3") NAILS SPACED 6" O.C. (2X 4 STUDS MINIMUM)

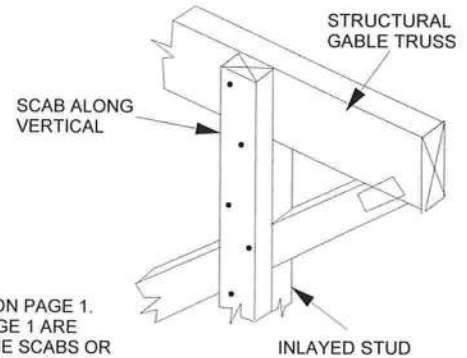

MAXIMUM STUD LENGTHS ARE LISTED ON PAGE 1. ALL BRACING METHODS SHOWN ON PAGE 1 ARE VALID AND ARE TO BE FASTENED TO THE SCABS OR VERTICAL STUDS OF THE STANDARD GABLE TRUSS ON THE INTERIOR SIDE OF THE STRUCTURE.

STRUCTURAL GABLE TRUSS

AN ADEQUATE DIAPHRAGM OR OTHER METHOD OF BRACING MUST BE PRESENT TO PROVIDE FULL LATERAL SUPPORT OF THE BOTTOM CHORD TO RESIST ALL OUT OF PLANE LOADS. THE BRACING SHOWN IN THIS DETAIL IS FOR THE VERTICAL/STUDS ONLY.

NOTE : THIS DETAIL IS TO BE USED ONLY FOR STRUCTURAL GABLES WITH INLAVED STUDS. TRUSSES WITHOUT INLAVED STUDS ARE NOT ADDRESSED HERE.

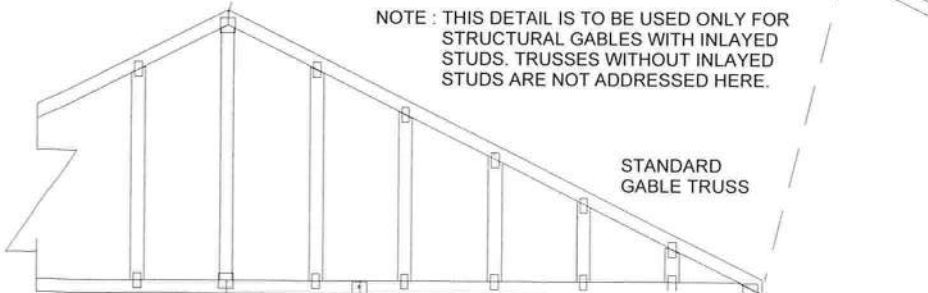

This item has been electronically signed and sealed by O'Regan, Philip, PE using a Digital Signature. Printed copies of this document are not considered signed and sealed and the signature must be verified on any electronic copies.

Philip J. O'Regan PE No.58126
MiTek USA, Inc. FL Cert 6634
6904 Parke East Blvd. Tampa FL 33610
Date:

April 2,2021

WARNING - Verify design parameters and READ NOTES ON THIS AND INCLUDED MITEK REFERENCE PAGE MII-7473 rev. 5/19/2020 BEFORE USE.

Design valid for use only with MiTek® connectors. This design is based only upon parameters shown, and is for an individual building component, not a truss system. Before use, the building designer must verify the applicability of design parameters and properly incorporate this design into the overall building design. Bracing indicated is to prevent buckling of individual truss web and/or chord members only. Additional temporary and permanent bracing is always required for stability and to prevent collapse with possible personal injury and property damage. For general guidance regarding the fabrication, storage, delivery, erection and bracing of trusses and truss systems, see ANSITPI Quality Criteria, DSB-89 and BCSI Building Component Safety Information available from Truss Plate Institute, 2670 Crain Highway, Suite 203 Waldorf, MD 20601



6904 Parke East Blvd.
Tampa, FL 36610

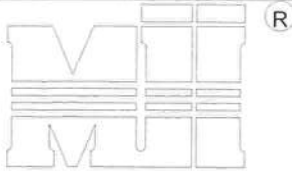

TRUSS CRITERIA:

- LOADING: 40-10-0-10
- DURATION FACTOR: 1.15
- SPACING: 24" O.C.
- TOP CHORD: 2x4 OR 2x6
- PITCH: 4/12 - 12/12
- HEEL HEIGHT: STANDARD HEEL UP TO 12" ENERGY HEEL
- END BEARING CONDITION

MiTek USA, Inc.

NOTES:

1. ATTACH 2x SCAB (MINIMUM NO.2 GRADE SPF, HF, SP, DF) TO ONE FACE OF TRUSS WITH TWO ROWS OF 10d (0.131" X 3") SPACED 6" O.C.
2. THE END DISTANCE, EDGE DISTANCE, AND SPACING OF NAILS SHALL BE SUCH AS TO AVOID UNUSUAL SPLITTING OF THE WOOD.
3. WHEN NAILING THE SCABS, THE USE OF A BACKUP WEIGHT IS RECOMMENDED TO AVOID LOOSENING OF THE CONNECTOR PLATES AT THE JOINTS OR SPLICES.

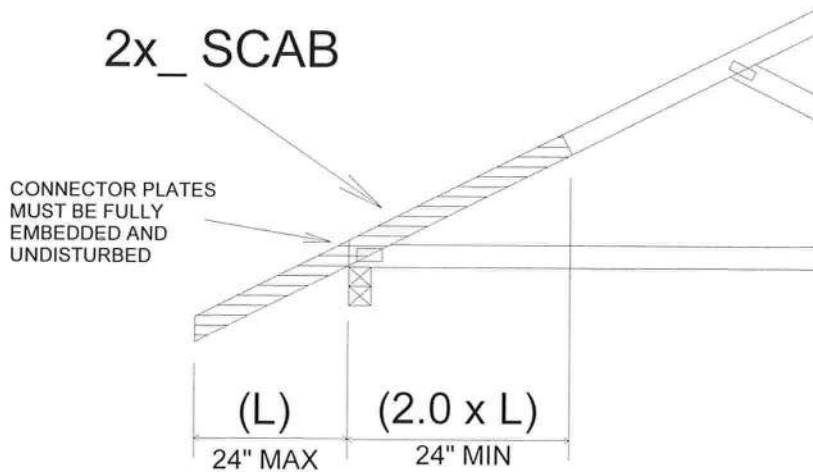

IMPORTANT

This detail to be used only with trusses (spans less than 40') spaced 24" o.c. maximum and having pitches between 4/12 and 12/12 and total top chord loads not exceeding 50 psf. Trusses not fitting these criteria should be examined individually.

REFER TO INDIVIDUAL TRUSS DESIGN FOR PLATE SIZES AND LUMBER GRADES

This item has been electronically signed and sealed by O'Regan, Philip, PE using a Digital Signature. Printed copies of this document are not considered signed and sealed and the signature must be verified on any electronic copies.

Philip J. O'Regan PE No.58126
MiTek USA, Inc. FL Cert 8634
6904 Parke East Blvd. Tampa FL 33610
Date:

April 2, 2021

WARNING - Verify design parameters and READ NOTES ON THIS AND INCLUDED MITEK REFERENCE PAGE MII-7473 rev. 5/19/2020 BEFORE USE.

Design valid for use only with MiTek® connectors. This design is based only upon parameters shown, and is for an individual building component, not a truss system. Before use, the building designer must verify the applicability of design parameters and properly incorporate this design into the overall building design. Bracing indicated is to prevent buckling of individual truss web and/or chord members only. Additional temporary and permanent bracing is always required for stability and to prevent collapse with possible personal injury and property damage. For general guidance regarding the fabrication, storage, delivery, erection and bracing of trusses and truss systems, see ANSITP11 Quality Criteria, DSB-89 and BCSI Building Component Safety Information available from Truss Plate Institute, 2670 Crain Highway, Suite 203 Waldorf, MD 20601



6904 Parke East Blvd.
Tampa, FL 36610

Philip J. O'Regan PE No.58126
MiTek USA, Inc. FL Cert 6634
6904 Parke East Blvd. Tampa FL 33610
Date:

April 2,202

 **WARNING** - Verify design parameters and READ NOTES ON THIS AND INCLUDED MITEK REFERENCE PAGE MII-7473 rev. 5/19/2020 BEFORE USE.

Design valid for use only with MiTek® connectors. This design is based only upon parameters shown, and is for an individual building component, not a truss system. Before use, the building designer must verify the applicability of design parameters and properly incorporate this design into the overall building design. Bracing indicated is to prevent buckling of individual truss web and/or chord members only. Additional temporary and permanent bracing is always required for stability and to prevent collapse with possible personal injury and property damage. For general guidance regarding the fabrication, storage, delivery, erection and bracing of trusses and truss systems, see **ANSI/TPI1 Quality Criteria, DSB-89 and BCSI Building Component Safety Information** available from Truss Plate Institute, 2670 Crain Highway, Suite 203 Waldorf, MD 20601



6904 Parke East Blvd.
Tampa, FL 36610

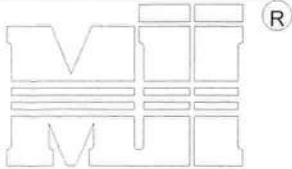

MiTek USA, Inc.

TO MINIMIZE VIBRATION COMMON TO ALL SHALLOW FRAMING SYSTEMS, 2x6 "STRONGBACK" IS RECOMMENDED, LOCATED EVERY 8 TO 10 FEET ALONG A FLOOR TRUSS.

NOTE 1: 2X6 STRONGBACK ORIENTED VERTICALLY MAY BE POSITIONED DIRECTLY UNDER THE TOP CHORD OR DIRECTLY ABOVE THE BOTTOM CHORD. SECURELY FASTENED TO THE TRUSS USING ANY OF THE METHODS ILLUSTRATED BELOW.

NOTE 2: STRONGBACK BRACING ALSO SATISFIES THE LATERAL BRACING REQUIREMENTS FOR THE BOTTOM CHORD OF THE TRUSS WHEN IT IS PLACED ON TOP OF THE BOTTOM CHORD, IS CONTINUOUS FROM END TO END, CONNECTED WITH A METHOD OTHER THAN METAL FRAMING ANCHOR, AND PROPERLY CONNECTED, BY OTHERS, AT THE ENDS.

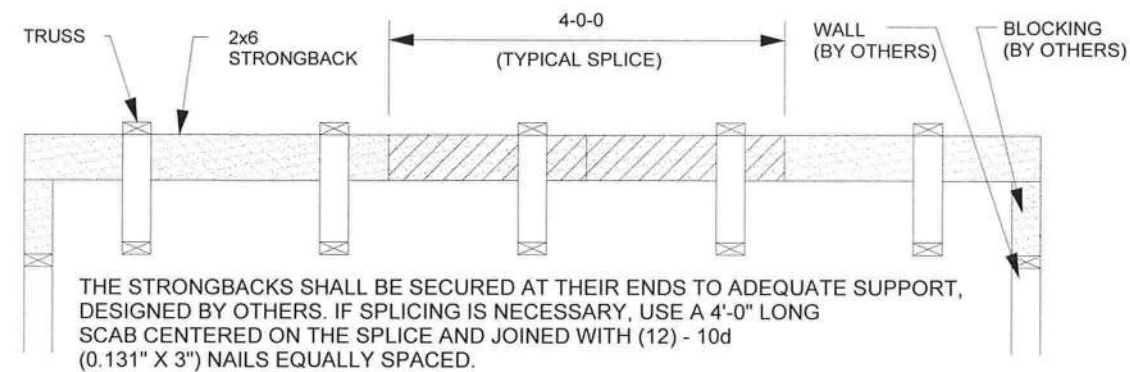
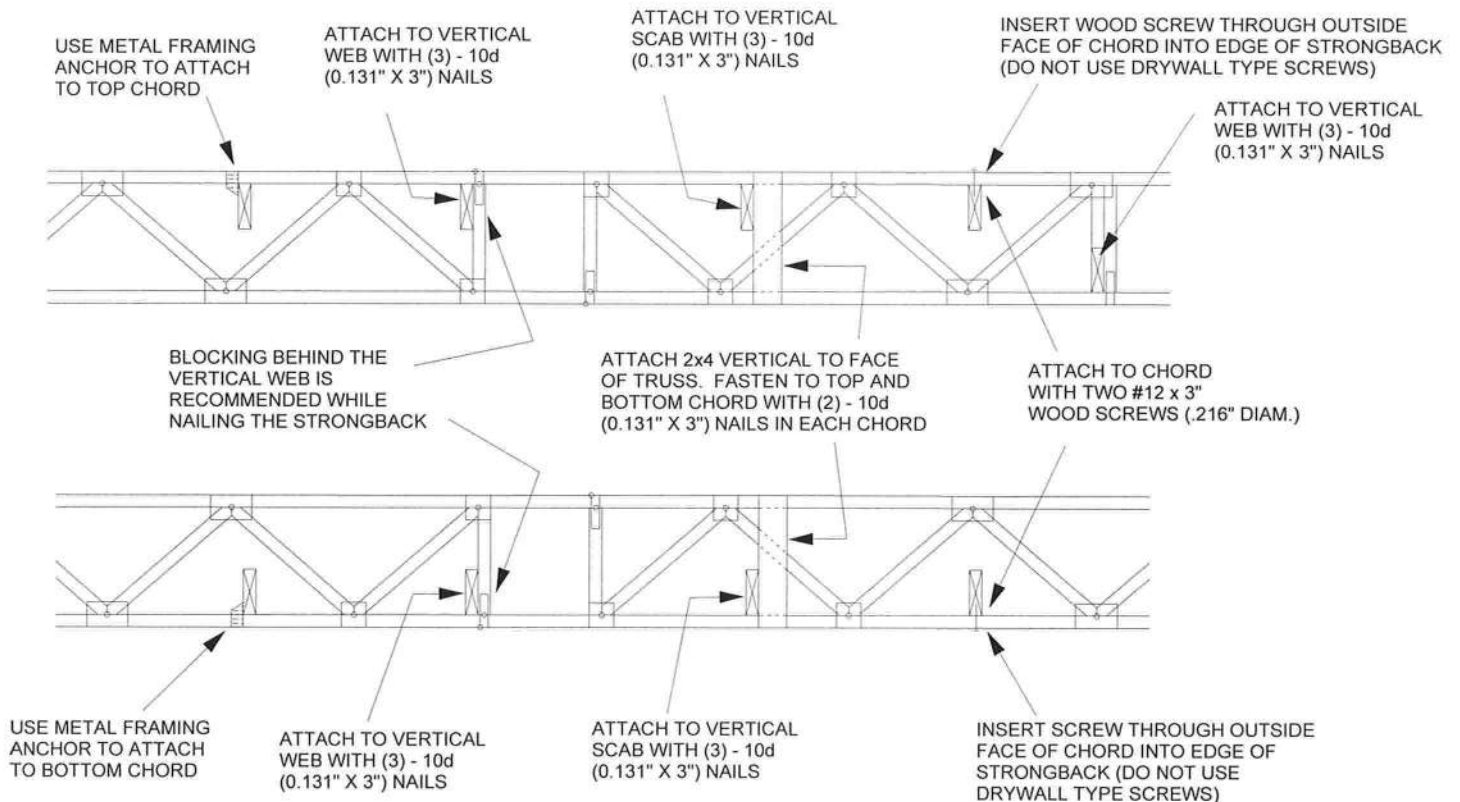

This item has been electronically signed and sealed by O'Regan, Philip, P using a Digital Signature. Printed copies of this document are not considered signed and sealed and the signature must be verified on any electronic copies.

Philip J. O'Regan PE No.58126
MiTek USA, Inc. FL Cert 6634
6904 Parke East Blvd. Tampa FL 33610
Date:

April 2,202

WARNING - Verify design parameters and READ NOTES ON THIS AND INCLUDED MITEK REFERENCE PAGE MII-7473 rev. 5/19/2020 BEFORE USE.

Design valid for use only with MiTek® connectors. This design is based only upon parameters shown, and is for an individual building component, not a truss system. Before use, the building designer must verify the applicability of design parameters and properly incorporate this design into the overall building design. Bracing indicated is to prevent buckling of individual truss web and/or chord members only. Additional temporary and permanent bracing is always required for stability and to prevent collapse with possible personal injury and property damage. For general guidance regarding the fabrication, storage, delivery, erection and bracing of trusses and truss systems, see

Safety Information available from Truss Plate Institute, 2670 Crain Highway, Suite 203 Waldorf, MD 20601



6904 Parke East Blvd.
Tampa, FL 33610

Symbols

PLATE LOCATION AND ORIENTATION

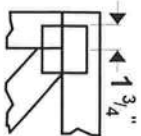

Center plate on joint unless x, y offsets are indicated. Dimensions are in 1/16-in-sixteenths. Apply plates to both sides of truss and fully embed teeth.

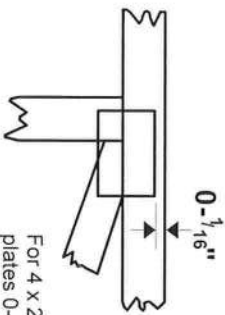

For 4 x 2 orientation, locate plates 0- 1/16" from outside edge of truss.



This symbol indicates the required direction of slots in connector plates.

* Plate location details available in MITek 20/20 software or upon request.

PLATE SIZE

4 X 4

The first dimension is the plate width measured perpendicular to slots. Second dimension is the length parallel to slots.

LATERAL BRACING LOCATION



Indicated by symbol shown and/or by text in the bracing section of the output. Use T or I bracing if indicated.

BEARING

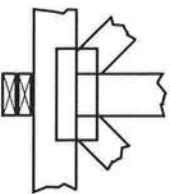

Indicates location where bearings (supports) occur. Icons vary but reaction section indicates joint number where bearings occur. Min size shown is for crushing only.

Industry Standards:

ANSI/TPI1: National Design Specification for Metal Plate Connected Wood Truss Construction.
DSB-89: Building Standard for Bracing.
BCSI: Building Component Safety Information, Guide to Good Practice for Handling, Installing & Bracing of Metal Plate Connected Wood Trusses.

Numbering System

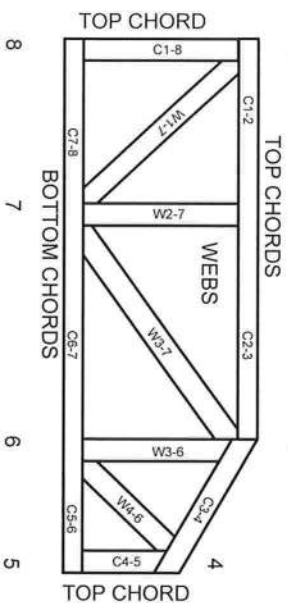

JOINTS ARE GENERALLY NUMBERED/LETTERED CLOCKWISE AROUND THE TRUSS STARTING AT THE JOINT FARTHEST TO THE LEFT.

CHORDS AND WEBS ARE IDENTIFIED BY END JOINT NUMBERS/LETTERS.

PRODUCT CODE APPROVALS

ICC-ES Reports:

ESR-1311, ESR-1352, ESR1988
ER-3907, ESR-2362, ESR-1397, ESR-3282

Trusses are designed for wind loads in the plane of the truss unless otherwise shown.

Lumber design values are in accordance with ANSI/TPI 1 section 6.3 These truss designs rely on lumber values established by others.

© 2012 MITek® All Rights Reserved



MITek Engineering Reference Sheet. Mill-7473 rev. 5/19/2020



General Safety Notes

Failure to Follow Could Cause Property Damage or Personal Injury

1. Additional stability bracing for truss system, e.g. diagonal or X-bracing, is always required. See BCSI.
2. Truss bracing must be designed by an engineer. For wide truss spacing, individual lateral braces themselves may require bracing, or alternative T or I bracing should be considered.
3. Never exceed the design loading shown and never stack materials on inadequately braced trusses.
4. Provide copies of this truss design to the building designer, erection supervisor, property owner and all other interested parties.
5. Cut members to bear tightly against each other.
6. Place plates on each face of truss at each joint and embed fully. Knots and wane at joint locations are regulated by ANSI/TPI 1.
7. Design assumes trusses will be suitably protected from the environment in accord with ANSI/TPI 1.
8. Unless otherwise noted, moisture content of lumber shall not exceed 19% at time of fabrication.
9. Unless expressly noted, this design is not applicable for use with fire retardant, preservative treated, or green lumber.
10. Camber is a non-structural consideration and is the responsibility of truss fabricator. General practice is to camber for dead load deflection.
11. Plate type, size, orientation and location dimensions indicated are minimum plating requirements.
12. Lumber used shall be of the species and size, and in all respects, equal to or better than that specified.
13. Top chords must be sheathed or purlins provided at spacing indicated on design.
14. Bottom chords require lateral bracing at 10 ft. spacing, or less, if no ceiling is installed, unless otherwise noted.
15. Connections not shown are the responsibility of others.
16. Do not cut or alter truss member or plate without prior approval of an engineer.
17. Install and load vertically unless indicated otherwise.
18. Use of green or treated lumber may pose unacceptable environmental, health or performance risks. Consult with project engineer before use.
19. Review all portions of this design (front, back, words and pictures) before use. Reviewing pictures alone is not sufficient.
20. Design assumes manufacture in accordance with ANSI/TPI 1 Quality Criteria.
21. The design does not take into account any dynamic or other loads other than those expressly stated.