

| FLORIDA BUILDING CODE              |  |
|------------------------------------|--|
| Compliance Summary                 |  |
| <b>TYPE OF CONSTRUCTION</b>        |  |
| Roof:                              | Hip Construction, Wood Trusses @ 24" O.C.                    |
| Walls:                             | 2x4 Wood Studs @ 16" O.C.                                    |
| Floor:                             | 4" Thk. Concrete Slab w/ Fiberglass Concrete Additive        |
| Foundation:                        | Continuous Footer/Beam Wall                                  |
| <b>ROOF DECKING</b>                |  |
| Material:                          | 1/2" CDX Plywood or 1/16" O.S.B.                             |
| Sheet Size:                        | 48"x96" Sheets Perpendicular to Roof Framing                 |
| Fasteners:                         | 8d Ring Shank per schedule on sheet 6.4                      |
| <b>SHEARWALLS</b>                  |  |
| Material:                          | 1/16" O.S.B. WINDSTORM BOARD                                 |
| Sheet Size:                        | 48"x96" Sheets Placed Vertical                               |
| Fasteners:                         | 8d Common Nails @ 4" O.C. Edges & 4" O.C. Interior           |
| Diaphragm:                         | Double Top Flats @ 12" O.C. w/ 2x4 Studs @ 16" O.C.          |
| Wall Studs:                        | 2x4 Studs @ 16" O.C.   |
| <b>HURRICANE UPLIFT CONNECTORS</b> |  |
| Truss Anchors:                     | SIMPSON H2.5a @ Ea. Truss End (Typ. U.O.N.)                  |
| Wall Tension:                      | Wall Sheathing Nailing Is Adequate - 8d @ 4" O.C. Top & Bot. |
| Anchor Bolts:                      | 1/2" A307 Bolts @ 48" O.C. - 1st Bolt 12"-16" from corner    |
| Corner Hold-down Device:           | (1) HTB @ each corner  |
| Porch Column Base Connector:       | Simpson ABU66 @ each column                                  |
| Porch Column to Beam Connector:    | Simpson EFC66/FC66 @ each column or (2) MSTA24 flat straps   |
| <b>FOOTINGS AND FOUNDATIONS</b>    |  |
| Footings:                          | 20"D x 12"W x CONT., CONCRETE FOOTING w/ 2 #5 REBAR.         |
| Int. Footings:                     | 12"D x 12"W x CONT., CONCRETE FOOTING w/ 2 #5 REBAR.         |

### FRAMING ANCHOR SCHEDULE

| APPLICATION                  | MANUFR/MODEL                                  | CAP.      |
|------------------------------|---|-----------|
| TRUSS TO WALL:               | SIMPSON H2.5a or SDCW15600                    | 600*      |
| GIRDER TRUSS TO POST/HEADER: | SIMPSON LGT, w/ 28 - 16d NAILS                | 1785*     |
| HEADER TO KING STUD(S):      | SIMPSON ST2                                   | 1370*     |
| FLATE TO STUD:               | NO CONNECTION REQ. WHEN USING WINDSTORM BOARD |           |
| STUD TO SILL:                | NO CONNECTION REQ. WHEN USING WINDSTORM BOARD |           |
| PORCH BEAM TO POST:          | SIMPSON PC66/EPC66                            | 1700*     |
| PORCH POST TO FND.:          | SIMPSON ABU66                                 | 2200*     |
| MISC. JOINTS                 | SIMPSON A34                                   | 315*/240* |

NOTE:  
ALL ANCHORS SHALL BE SECURED w/ NAILS AS PRESCRIBED BY THE MANUFACTURER FOR MAXIMUM JOINT STRENGTH, UNLESS NOTED OTHERWISE.

NOTE:  
REFER TO THE INCLUDED STRUCTURAL DETAILS FOR ADDITIONAL ANCHORS/ JOINT REINFORCEMENT AND FASTENERS.

NOTE:  
ALL UNLISTED JOINTS IN THE LOAD PATH SHALL BE REINFORCED WITH SIMPSON A34 FRAMING ANCHORS, TYPICAL T.O.

NOTE:  
"BEMCO" PRODUCT APPROVAL:  
MIAMI/DADE COUNTY REPORT #95-0818.15

NOTE:  
"SIMPSON" PRODUCT APPROVALS:  
MIAMI/DADE COUNTY REPORT #31-0107.05, #26-1126.11, #93-0623.04  
8BCCI NER-443, NER-393

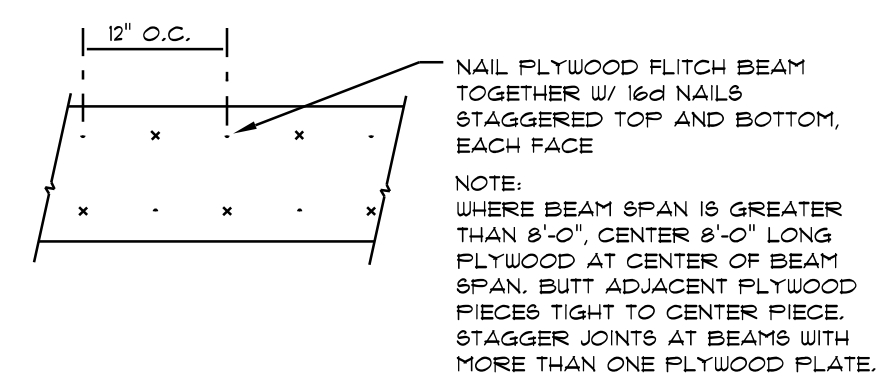

### PLYWOOD FLITCH BEAM DETAIL

NOT TO SCALE

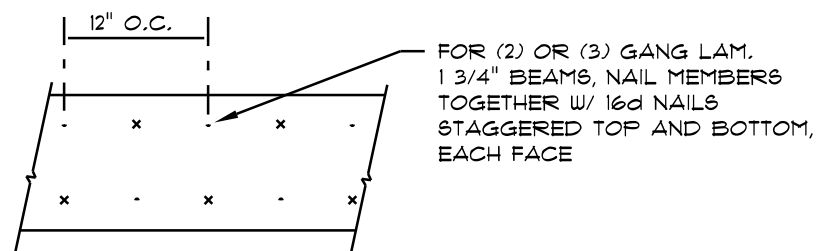

### MULTIPLE GANG LAM. DETAIL

NOT TO SCALE

### B/U Beam DETAILS

SCALE: NONE

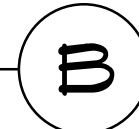

### General Roofing NOTES:

DECK REQUIREMENTS:  
ASPHALT SHINGLES SHALL BE FASTENED TO SOLIDLY SHEATHED DECKS.

SLOPE:  
ASPHALT SHINGLES SHALL BE USED ONLY ON ROOF SLOPES OF 2:12 OR GREATER. FOR ROOF SLOPES FROM 2:12 TO 4:12, DBL UNDERLAYMENT IS REQUIRED.

UNDERLAYMENT:  
TWO LAYERS OF ASTM D226 TYPE II or ASTM D4869 TYPE III or TYPE IV UNDERLAYMENT SHALL BE INSTALLED AS FOLLOWS:

- STARTING AT THE EAVE, A 19 INCH STRIP OF UNDERLAYMENT SHALL BE APPLIED PARALLEL WITH THE EAVE AND FASTENED SUFFICIENTLY TO STAY IN PLACE.
- STARTING AT THE EAVE, 36 INCH WIDE STRIPS OF UNDERLAYMENT FELT SHALL BE APPLIED OVERLAPPING SUCCESSIVE SHEETS 19 INCHES AND FASTENED SUFFICIENTLY TO STAY IN PLACE.

ASPHALT SHINGLES:  
ASPHALT SHINGLES SHALL HAVE SELF SEAL STRIPS OR BE INTERLOCKING, AND COMPLY WITH ASTM D 225 OR ASTM D 3462.

FASTENERS:  
FASTENERS FOR ASPHALT SHINGLES SHALL BE GALVANIZED, STAINLESS STEEL, ALUMINUM OR COPPER ROOFING NAILS, MINIMUM 12 GAUGE SHANK WITH A MINIMUM 3/8 INCH DIAMETER HEAD, OF A LENGTH TO PENETRATE THROUGH THE ROOFING MATERIAL AND A MINIMUM 3/4" INTO THE ROOF SHEATHING. WHERE THE SHEATHING IS LESS THAN 3/4" THICK, THE NAILS SHALL PENETRATE THROUGH THE SHEATHING.

ATTACHMENT:  
ASPHALT SHINGLES SHALL BE SECURED TO THE ROOF WITH NOT LESS THAN FOUR FASTENERS PER STRIP SHINGLE OR TWO FASTENERS PER INDIVIDUAL SHINGLE. WHERE ROOFS LOCATED IN BASIC WIND SPEED OF 100 MPH OR GREATER, SPECIAL METHODS OF FASTENING ARE REQUIRED. UNLESS OTHERWISE NOTED, ATTACHMENT OF ASPHALT SHINGLES SHALL CONFORM WITH ASTM D 3161 OR M-DC PA 107-95.

BASE AND CAP FLASHINGS:  
BASE AND CAP FLASHING SHALL BE INSTALLED IN ACCORDANCE w/ MFG'S INSTALLATION INSTRUCTIONS. BASE FLASHING SHALL BE OF EITHER CORROSION RESISTANT METAL OF MINIMUM NOMINAL THICKNESS 0.019 INCH OR MINERAL SURFACE ROLL ROOFING WEIGHING A MINIMUM OF 71 LBS PER 100 SQUARE FEET. CAP FLASHING SHALL BE CORROSION RESISTANT METAL OF MINIMUM NOMINAL THICKNESS OF 0.019 INCH.

VALLEYS:  
VALLEY LININGS SHALL BE INSTALLED IN ACCORDANCE w/ MANUFACTURER'S INSTALLATION INSTRUCTIONS BEFORE APPLYING ASPHALT SHINGLES. VALLEY LININGS OF THE FOLLOWING TYPES SHALL BE PERMITTED:

- FOR OPEN VALLEYS LINED WITH METAL, THE VALLEY LINING SHALL BE AT LEAST 16" WIDE AND OF ANY OF THE CORROSION RESISTANT METALS IN FBC TABLE 1507.3.9.2.
- FOR OPEN VALLEYS, VALLEY LINING OF TWO PLYS OF MINERAL SURFACE ROLL ROOFING SHALL BE PERMITTED. THE BOTTOM LAYER SHALL BE 19 INCHES AND THE TOP LAYER A MINIMUM OF 36 INCHES WIDE.
- FOR CLOSED VALLEYS VALLEY LINING SHALL BE ONE OF THE FOLLOWING:
  - BOTH TYPES 1 AND 2 ABOVE, COMBINED.
  - ONE PLY OF SMOOTH ROLL ROOFING AT LEAST 36 INCHES WIDE AND COMPLYING WITH ASTM D 224.
  - SPECIALTY UNDERLAYMENT AT LEAST 36 INCHES WIDE AND COMPLYING WITH ASTM D 1570.

### STRUCTURAL DESIGN CRITERIA:

1. THE DESIGN COMPLIES WITH THE REQUIREMENTS OF THE 2023 FLORIDA, 8th EDITION BUILDING CODE - SECTION 1609 AND OTHER REFERENCED CODES AND SPECIFICATIONS. ALL CODES AND SPECIFICATIONS SHALL BE LATEST EDITION AT TIME OF PERMIT.

2. WIND LOAD CRITERIA: RISK CATEGORY: 2, EXPOSURE: "B"

BASED ON ANSI/AISC 1-22, 2023 FBC 1609-4 WIND VELOCITY:  $V_{ULT} = 130$  MPH  
 $V_{SD} = 101$  MPH

3. ROOF DESIGN LOADS:  
SUPERIMPOSED DEAD LOADS: 20 PSF  
SUPERIMPOSED LIVE LOADS: 20 PSF

4. FLOOR DESIGN LOADS:  
SUPERIMPOSED DEAD LOADS: 25 PSF  
SUPERIMPOSED LIVE LOADS:  
RESIDENTIAL: 40 PSF  
BALCONIES: 60 PSF

5. WIND NET UPLIFT: ARE AS INDICATED ON PLANS

### TERMITE PROTECTION NOTES:

SOIL CHEMICAL BARRIER METHOD:

1. A PERMANENT SIGN WHICH IDENTIFIES THE TERMITE TREATMENT PROVIDER AND NEED FOR REINSPECTION AND TREATMENT CONTRACT RENEWAL SHALL BE PROVIDED. THE SIGN SHALL BE POSTED NEAR THE WATER HEATER OR ELECTRIC PANEL. FBC 1403.2.6

2. CONDENSATE AND ROOF DOWNSPOUTS SHALL DISCHARGE AT LEAST 1'-0" AWAY FROM BUILDING SIDE WALLS. FBC 1503.4.4

3. IRRIGATION/SPRINKLER SYSTEMS INCLUDING ALL RISERS AND SPRAY HEADS SHALL NOT BE INSTALLED WITHIN 1'-0" FROM BUILDING SIDE WALLS. FBC 1503.4.4

4. TO PROVIDE FOR INSPECTION FOR TERMITE INFESTATION, BETWEEN WALL COVERINGS AND FINAL EARTH GRADE SHALL NOT BE LESS THAN 6". EXCEPTION: PAINT AND DECORATIVE CEMENTIOUS FINISH LESS THAN 5/8" THICK ADHERED DIRECTLY TO THE FOUNDATION WALL. FBC 1403.1.6

5. INITIAL TREATMENT SHALL BE DONE AFTER ALL EXCAVATION AND BACKFILL IS COMPLETE. FBC 1016.1.1

6. SOIL DISTURBED AFTER THE INITIAL TREATMENT SHALL BE RETREATED INCLUDING SPACES BOXED OR FORMED. FBC 1016.1.2

7. BOXED AREAS IN CONCRETE FLOOR FOR SUBSEQUENT INSTALLATION OF TRAPS, ETC., SHALL BE MADE WITH PERMANENT METAL OR PLASTIC FORMS. PERMANENT FORMS MUST BE OF A SIZE AND DEPTH THAT WILL ELIMINATE THE DISTURBANCE OF SOIL AFTER THE INITIAL TREATMENT. FBC 1016.1.3

8. MINIMUM 6 MIL VAPOR RETARDER MUST BE INSTALLED TO PROTECT AGAINST RAINFALL DILUTION. IF RAINFALL OCCURS BEFORE VAPOR RETARDER PLACEMENT, RETREATMENT IS REQUIRED. FBC 1016.1.4

9. CONCRETE OVERPOUR AND MORTAR ALONG THE FOUNDATION PERIMETER MUST BE REMOVED BEFORE EXTERIOR SOIL TREATMENT. FBC 1016.1.5

10. SOIL TREATMENT MUST BE APPLIED UNDER ALL EXTERIOR CONCRETE OR GRADE WITHIN 1'-0" OF THE STRUCTURE SIDEWALLS. FBC 1016.1.6

11. AN EXTERIOR VERTICAL CHEMICAL BARRIER MUST BE INSTALLED AFTER CONSTRUCTION IS COMPLETE INCLUDING LANDSCAPING AND IRRIGATION. ANY SOIL DISTURBED AFTER THE VERTICAL BARRIER IS APPLIED, SHALL BE RETREATED. FBC 1016.1.6

12. ALL BUILDINGS ARE REQUIRED TO HAVE PER-CONSTRUCTION TREATMENT. FBC 1016.1.7

13. A CERTIFICATE OF COMPLIANCE MUST BE ISSUED TO THE BUILDING DEPARTMENT BY A LICENSED PEST CONTROL COMPANY BEFORE A CERTIFICATE OF OCCUPANCY WILL BE ISSUED. THE CERTIFICATE OF COMPLIANCE SHALL STATE: "THE BUILDING HAS RECEIVED A COMPLETE TREATMENT FOR THE PREVENTION OF SUBTERRANEAN TERMITES. THE TREATMENT IS IN ACCORDANCE WITH THE RULES AND LAWS OF THE FLORIDA DEPARTMENT OF AGRICULTURE AND CONSUMER SERVICES". FBC 1016.1.7

14. AFTER ALL WORK IS COMPLETED, LOOSE WOOD AND FILL MUST BE REMOVED FROM BELOW AND WITHIN 1'-0" OF THE BUILDING. THIS INCLUDES ALL GRADE STAKES, TRAP BOXES, FORMS, SHORING OR OTHER CELLULOSE CONTAINING MATERIAL. FBC 2303.1.3

15. NO WOOD, VEGETATION, STUMPS, CARDBOARD, TRASH, ETC., SHALL BE BURIED WITHIN 5'-0" OF ANY BUILDING OR PROPOSED BUILDING. FBC 2303.1.4

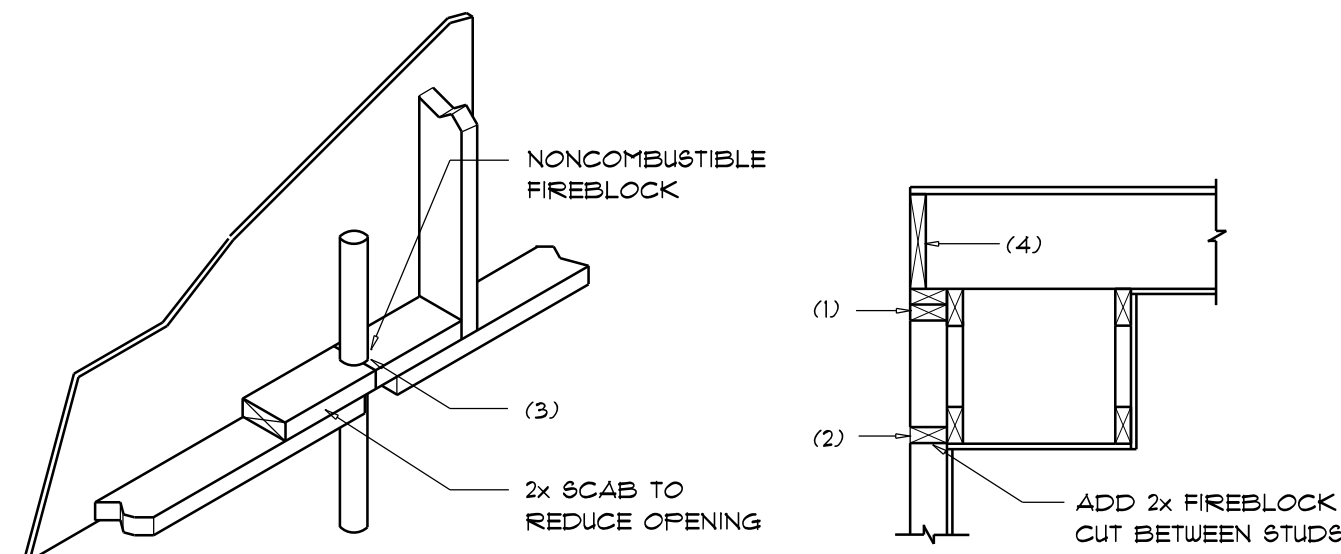

### PENETRATIONS

### SOFFIT/DROPPED CLG.

### FIREBLOCKING NOTES:

FIREBLOCKING SHALL BE INSTALLED IN WOOD FRAME CONSTRUCTION IN THE FOLLOWING LOCATIONS:

- IN CONCEALED SPACES OF STUD WALLS AND PARTITIONS INCLUDING FURRED SPACES AT CEILING AND FLOOR LEVELS.
- AT ALL INTERCONNECTIONS BETWEEN CONCEALED VERTICAL AND HORIZONTAL SPACES SUCH AS OCCUR AT SOFFITS, DROP CEILING, COVE CEILING, ETC.
- AT OPENINGS AROUND VENTS, PIPES, DUCTS, CHIMNEYS AND FIREPLACES AT CEILING AND FLOOR LEVELS WITH "PYROPANEL MULTIFLEX SEALANT"
- AT ALL INTERCONNECTIONS BETWEEN CONCEALED VERTICAL STUD WALL OR PARTITION SPACES AND CONCEALED SPACES CREATED BY AN ASSEMBLY OF FLOOR JOISTS, FIREBLOCKING SHALL BE PROVIDED FOR THE FULL DEPTH OF THE JOISTS AT THE ENDS AND OVER THE SUPPORTS.

### Fire Stopping DETAILS

SCALE: NONE

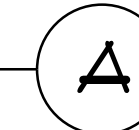

| BUILDING COMPONENTS & CLADDING LOADS |                  | MEAN BUILDING HEIGHT = 30.0', EXPOSURE "B" ROOF ANGLE T TO T' |              |              |              |
|--------------------------------------|------------------|---|--------------|--------------|--------------|
| WIND DIR.                            | WIND SPEED (MPH) | VULT 10 MPH   | VULT 120 MPH | VULT 130 MPH | VULT 140 MPH |
| ROOF T. TO T'                        | 1 IO             | 12.0 / -19.9  | 14.9 / -23.1 | 17.5 / -21.8 | 20.3 / -32.3 |
|                                      | 2 IO             | 11.4 / -19.4  | 13.6 / -23.0 | 16.0 / -21.0 | 18.5 / -31.4 |
|                                      | 3 EO             | 10.0 / -18.6  | 11.9 / -22.2 | 13.9 / -26.0 | 16.1 / -30.2 |
| ROOF T. TO FT.                       | 2 IO             | 12.5 / -34.1  | 14.9 / -41.3 | 17.5 / -48.4 | 20.3 / -56.2 |
|                                      | 2 IO             | 11.4 / -31.9  | 13.6 / -38.0 | 16.0 / -44.6 | 18.5 / -51.1 |
|                                      | 3 EO             | 10.0 / -28.2  | 11.9 / -33.6 | 13.9 / -39.4 | 16.1 / -45.1 |
| WALL                                 | 3 IO             | 12.5 / -51.3  | 14.9 / -61.0 | 17.5 / -71.6 | 20.3 / -83.1 |
|                                      | 3 IO             | 11.4 / -47.9  | 13.6 / -57.1 | 16.0 / -67.0 | 18.5 / -77.1 |
|                                      | 3 EO             | 10.0 / -43.5  | 11.9 / -51.8 | 13.9 / -60.8 | 16.1 / -70.9 |
| WALL                                 | 4 IO             | 21.8 / -23.6  | 25.9 / -34.1 | 30.4 / -33.0 | 35.3 / -38.2 |
|                                      | 4 IO             | 20.8 / -22.6  | 24.7 / -26.9 | 29.0 / -31.6 | 33.7 / -36.1 |
|                                      | 4 EO             | 19.5 / -21.3  | 23.2 / -25.4 | 27.2 / -29.8 | 31.6 / -34.6 |
| WALL                                 | 5 IO             | 21.8 / -29.1  | 25.9 / -34.1 | 30.4 / -40.1 | 35.3 / -41.2 |
|                                      | 5 IO             | 20.8 / -27.2  | 24.7 / -32.4 | 29.0 / -38.0 | 33.7 / -44.0 |
|                                      | 5 EO             | 19.5 / -24.6  | 23.2 / -29.3 | 27.2 / -34.3 | 31.6 / -39.8 |

| HEIGHT & EXPOSURE ADJUSTMENT COEFFICIENTS FOR BUILDING COMPONENTS & CLADDING |              |              |              |
|--|--------------|--------------|--------------|
| BLDG HEIGHT  | EXPOSURE "B" | EXPOSURE "C" | EXPOSURE "D" |
| 15   | .82          | 1.21         | 1.41         |
| 20   | .89          | 1.28         | 1.55         |
| 25   | .94          | 1.35         | 1.61         |
| 30   | 1.00         | 1.40         | 1.66         |

REVISIONS  
Aug. 7th, 2024

A CUSTOM PROJECT FOR:  
**NEW MILLENNIUM - GUARD HOUSE**  
LAKE CITY, FLORIDA

**NICHOLAS PAUL GEISLER ARCHITECT**  
1758 N.W. Byron Rd.  
Lake City, FL 32095  
(386) 755-9071  
N.C.A.R.B. Certified

SHEET NUMBER  
**S.3**  
OF 4 SHEETS

N. P. GEISLER  
Digitally signed by N. P. GEISLER  
DN: cn = N. P. GEISLER, email = ngeisler178@gmail.com, c = US, o = ARCHITECT, ou = AR0007005  
Date: 2024.08.07 12:06:13 -0500  
AR0007005