

Cantilevered Retaining Wall

Project File: stallings.ec6

LIC# : KW-06015106, Build:20.24.09.03

CAROL CHADWICK, PE

(c) ENERCALC, LLC 1982-2024

DESCRIPTION: 6' wall CMU

FBC 2023, 8TH ED. - RESIDENTIAL

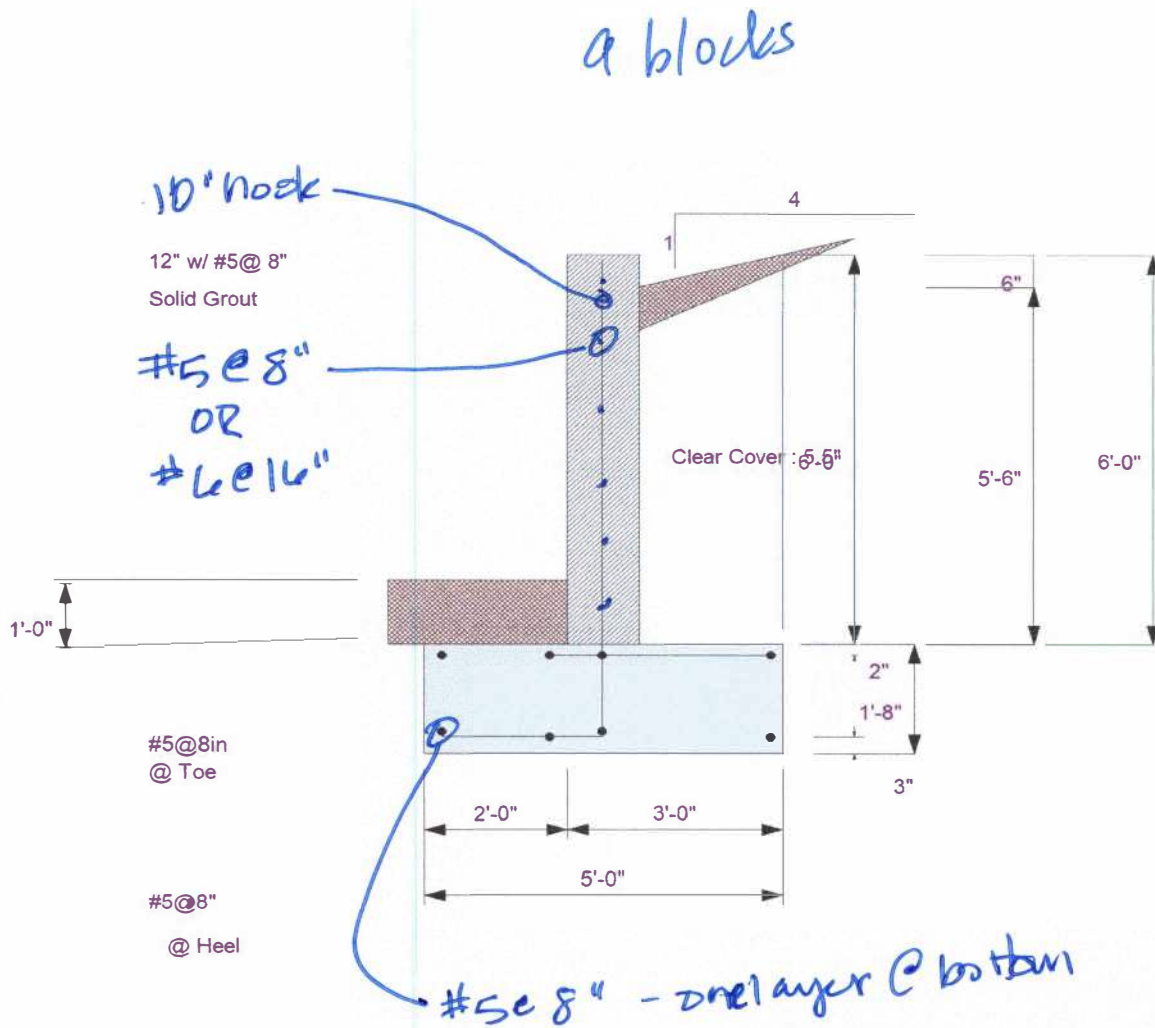

10" neck
 12" w/ #5 @ 8"
 Solid Grout
 #5 @ 8"
 OR
 #6 @ 16"

#5 @ 8in
 @ Toe
 #5 @ 8"
 @ Heel

#5 @ 8" - one layer @ bottom
 OR
 #5 @ 16" - two layer @ top & bottom

Carol Chadwick, P.E.
 P.E. License No. 82560
 307.680.1772
 ccpeuyo@gmail.com

This item has been digitally signed and sealed by Carol Chadwick, P.E. on the date adjacent to the seal. Printed copies of this document are not considered signed and sealed and the signature must be verified on any electronic copies.



Digitally signed by
 Carol Chadwick
 DN: c=US,
 o=Florida,
 dnQualifier=A0141
 0D0000018D463B4
 E7500032FEE,
 cn=Carol Chadwick
 Date: 2024.11.20
 14:10:24 -05'00'

Cantilevered Retaining Wall

Project File: stallings.ec6

LIC# : KW-06015106, Build:20.24.09.03

CAROL CHADWICK, PE

(c) ENERCALC, LLC 1982-2024

DESCRIPTION: 6' wall CMU

FBC 2023, 8TH ED. - RESIDENTIAL

Code Reference:

Calculations per IBC 2012 1807.3, CBC 2013, ASCE 7-10

Criteria

Retained Height	=	5.50 ft
Wall height above soil	=	0.50 ft
Slope Behind Wall	=	4.00
Height of Soil over Toe	=	12.00 in
Water table above bottom of footing	=	0.0 ft

Soil Data

Allow Soil Bearing	=	2,500.0 psf
Equivalent Fluid Pressure Method		
Active Heel Pressure	=	35.0 psf/ft
	=	
Passive Pressure	=	250.0 psf/ft
Soil Density, Heel	=	110.00 pcf
Soil Density, Toe	=	110.00 pcf
Footing Soil Friction	=	0.400
Soil height to ignore for passive pressure	=	12.00 in

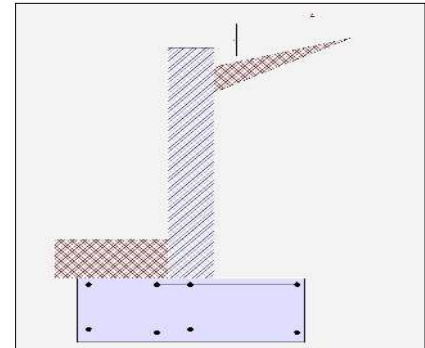

Surcharge Loads

Surcharge Over Heel	=	0.0 psf
Used To Resist Sliding & Overturning		
Surcharge Over Toe	=	0.0
Used for Sliding & Overturning		

Axial Load Applied to Stem

Axial Dead Load	=	0.0 lbs
Axial Live Load	=	0.0 lbs
Axial Load Eccentricity	=	0.0 in

Lateral Load Applied to Stem

Lateral Load	=	0.0 #/ft
...Height to Top	=	0.00 ft
...Height to Bottom	=	0.00 ft
Load Type	=	Wind (W) (Service Level)
Wind on Exposed Stem	=	0.0 psf (Strength Level)

Adjacent Footing Load

Adjacent Footing Load	=	0.0 lbs
Footing Width	=	0.00 ft
Eccentricity	=	0.00 in
Wall to Ftg CL Dist	=	0.00 ft
Footing Type	=	Spread Footing
Base Above/Below Soil at Back of Wall	=	0.0 ft
Poisson's Ratio	=	0.300

Cantilevered Retaining Wall

Project File: stallings.ec6

LIC# : KW-06015106, Build:20.24.09.03

CAROL CHADWICK, PE

(c) ENERCALC, LLC 1982-2024

DESCRIPTION: 6' wall CMU

FBC 2023, 8TH ED. - RESIDENTIAL

Design Summary

Wall Stability Ratios

Overturning	=	3.20	OK
Sliding	=	1.81	OK
Global Stability	=	3.55	

Total Bearing Load	=	3,228	lbs
...resultant ecc.	=	4.58	in

Eccentricity within middle third

Soil Pressure @ Toe	=	797	psf OK
Soil Pressure @ Heel	=	297	psf OK
Allowable	=	2,500	psf

Soil Pressure Less Than Allowable

ACI Factored @ Toe	=	1,116	psf
ACI Factored @ Heel	=	415	psf
Footing Shear @ Toe	=	5.1	psi OK
Footing Shear @ Heel	=	4.8	psi OK
Allowable	=	82.2	psi

Sliding Calcs

Lateral Sliding Force	=	1,028.6	lbs
less 100% Passive Force	=	763.9	lbs
less 100% Friction Force	=	1,094.0	lbs
Added Force Req'd	=	0.0	lbs OK
...for 1.5 Stability	=	0.0	lbs OK

Vertical component of active lateral soil pressure IS NOT considered in the calculation of soil bearing

Load Factors

Building Code	
Dead Load	1.200
Live Load	1.600
Earth, H	1.600
Wind, W	1.600
Seismic, E	1.000

Stem Construction

Design Height Above Ftg	ft =	0.00
Wall Material Above "Ht"	=	Masonry
Design Method	=	ASD
Thickness	=	12.00
Rebar Size	=	# 5
Rebar Spacing	=	8.00
Rebar Placed at	=	Center

Design Data

fb/FB + fa/Fa	=	0.249
---------------	---	-------

Total Force @ Section

Service Level	lbs =	529.4
Strength Level	lbs =	

Moment....Actual

Service Level	ft-# =	970.5
Strength Level	ft-# =	

Moment.....Allowable	=	3,887.8
----------------------	---	---------

Shear.....Actual

Service Level	psi =	3.8
Strength Level	psi =	

Shear.....Allowable	psi =	43.6
---------------------	-------	------

Anet (Masonry)	in2 =	139.50
----------------	-------	--------

Wall Weight	psf =	0.0
-------------	-------	-----

Rebar Depth 'd'	in =	5.81
-----------------	------	------

Masonry Data

f'm	psi =	1,500
Fs	psi =	20,000
Solid Grouting	=	Yes
Modular Ratio 'n'	=	21.48
Equiv. Solid Thick.	in =	11.63
Masonry Block Type	=	
Masonry Design Method	=	ASD

Concrete Data

f'c	psi =	
Fy	psi =	

Project Title: STALLINGS RETAINING WALL
 Engineer: CAROL CHADWICK, PE
 Project ID: FL21247
 Project Descr:

Cantilevered Retaining Wall

Project File: stallings.ec6

LIC# : KW-06015106, Build:20.24.09.03

CAROL CHADWICK, PE

(c) ENERCALC, LLC 1982-2024

DESCRIPTION: 6' wall CMU

FBC 2023, 8TH ED. - RESIDENTIAL

Footing Data

Toe Width	=	2.00 ft
Heel Width	=	3.00
Total Footing Width	=	5.00
Footing Thickness	=	20.00 in

f'c =	3,000 psi	Fy =	60,000 psi
Footing Concrete Density	=	150.00 pcf	
Min. As %	=	0.0018	
Cover @ Top	2.00	@ Btm.=	3.00 in

Footing Design Results

	<u>Toe</u>	<u>Heel</u>	
Factored Pressure	= 1,116	415	psf
Mu' : Upward	= 2,046	1,018	ft-#
Mu' : Downward	= 1,080	2,670	ft-#
Mu: Design	= 966	1,652	ft-#
ϕ Mn	= 33,965	36,057	ft-#
Actual 1-Way Shear	= 5.05	4.79	psi
Allow 1-Way Shear	= 82.16	82.16	psi
Toe Reinforcing	= # 5 @ 8.00 in		
Heel Reinforcing	= # 5 @ 8.00 in		
Key Reinforcing	= None Spec'd		
Footing Torsion, Tu	=	0.00	ft-lbs
Footing Allow. Torsion, ϕ Tn	=	0.00	ft-lbs

If torsion exceeds allowable, provide supplemental design for footing torsion.

Other Acceptable Sizes & Spacings

Toe: #4@ 5.55 in, #5@ 8.61 in, #6@ 12.22 in, #7@ 16.66 in, #8@ 21.94 in, #9@ 27.77 in, #10@ 35.27 in

Heel: #4@ 5.55 in, #5@ 8.61 in, #6@ 12.22 in, #7@ 16.66 in, #8@ 21.94 in, #9@ 27.77 in, #10@ 35.27 in

Key: No key defined

Min footing T&S reinf Area	2.16	in ²
Min footing T&S reinf Area per foot	0.43	in ² /ft

If one layer of horizontal bars:

#4@ 5.56 in
 #5@ 8.61 in
 #6@ 12.22 in

If two layers of horizontal bars:

#4@ 11.11 in
 #5@ 17.22 in
 #6@ 24.44 in

Cantilevered Retaining Wall

Project File: stallings.ec6

LIC# : KW-06015106, Build:20.24.09.03

CAROL CHADWICK, PE

(c) ENERCALC, LLC 1982-2024

DESCRIPTION: 6' wall CMU

FBC 2023, 8TH ED. - RESIDENTIAL

Summary of Overturning & Resisting Forces & Moments

ItemOVERTURNING.....		RESISTING.....			
	Force lbs	Distance ft	Moment ft-#	Force lbs	Distance ft	Moment ft-#	
HL Act Pres (ab water tbl)	1,028.6	2.56	2,628.7	Soil Over HL (ab. water tbl)	1,210.0	4.00	4,840.0
HL Act Pres (be water tbl)				Soil Over HL (bel. water tbl)		4.00	4,840.0
Hydrostatic Force				Water Table			
Buoyant Force =				Sloped Soil Over Heel =	55.0	4.33	238.3
Surcharge over Heel =				Surcharge Over Heel =			
Surcharge Over Toe =				Adjacent Footing Load =			
Adjacent Footing Load =				Axial Dead Load on Stem =			
Added Lateral Load =				* Axial Live Load on Stem =			
Load @ Stem Above Soil =				Soil Over Toe =	220.0	1.00	220.0
				Surcharge Over Toe =			
				Stem Weight(s) =			
				Earth @ Stem Transitions =			
Total	= 1,028.6	O.T.M. =	2,628.7	Footing Weight =	1,250.0	2.50	3,125.0
				Key Weight =		2.00	
				Vert. Component =			
Resisting/Overturning Ratio		= 3.20		Total =	2,735.0 lbs	R.M.=	8,423.3
Vertical Loads used for Soil Pressure =		3,228.4 lbs		* Axial live load NOT included in total displayed, or used for overturning resistance, but is included for soil pressure calculation.			

Vertical component of active lateral soil pressure IS NOT considered in the calculation of Sliding Resistance.

Vertical component of active lateral soil pressure IS NOT considered in the calculation of Overturning Resistance.

Tilt

Horizontal Deflection at Top of Wall due to settlement of soil

(Deflection due to wall bending not considered)

Soil Spring Reaction Modulus 250.0 pci

Horizontal Defl @ Top of Wall (approximate only) 0.027 in

The above calculation is not valid if the heel soil bearing pressure exceeds that of the toe, because the wall would then tend to rotate into the retained soil.

Project Title: STALLINGS RETAINING WALL
Engineer: CAROL CHADWICK, PE
Project ID: FL21247
Project Descr:

Cantilevered Retaining Wall

Project File: stallings.ec6

LIC# : KW-06015106, Build:20.24.09.03

CAROL CHADWICK, PE

(c) ENERCALC, LLC 1982-2024

DESCRIPTION: 6' wall CMU

FBC 2023, 8TH ED. - RESIDENTIAL

Rebar Lap & Embedment Lengths Information

Stem Design Segment: Bottom

Stem Design Height: 0.00 ft above top of footing

Calculated Rebar Stress, f_s = 4992.59 psi

Lap Splice length for #5 bar specified in this stem design segment (25.4.2.3a) = 25.00 in

Development length for #5 bar specified in this stem design segment = 12.00 in

Hooked embedment length into footing for #5 bar specified in this stem design segment = 6.39 in

As Provided = 0.4650 in²/ft

As Required = 0.1124 in²/ft

Cantilevered Retaining Wall

Project File: stallings.ec6

LIC# : KW-06015106, Build:20.24.09.03

CAROL CHADWICK, PE

(c) ENERCALC, LLC 1982-2024

DESCRIPTION: 6' wall CMU

FBC 2023, 8TH ED. - RESIDENTIAL

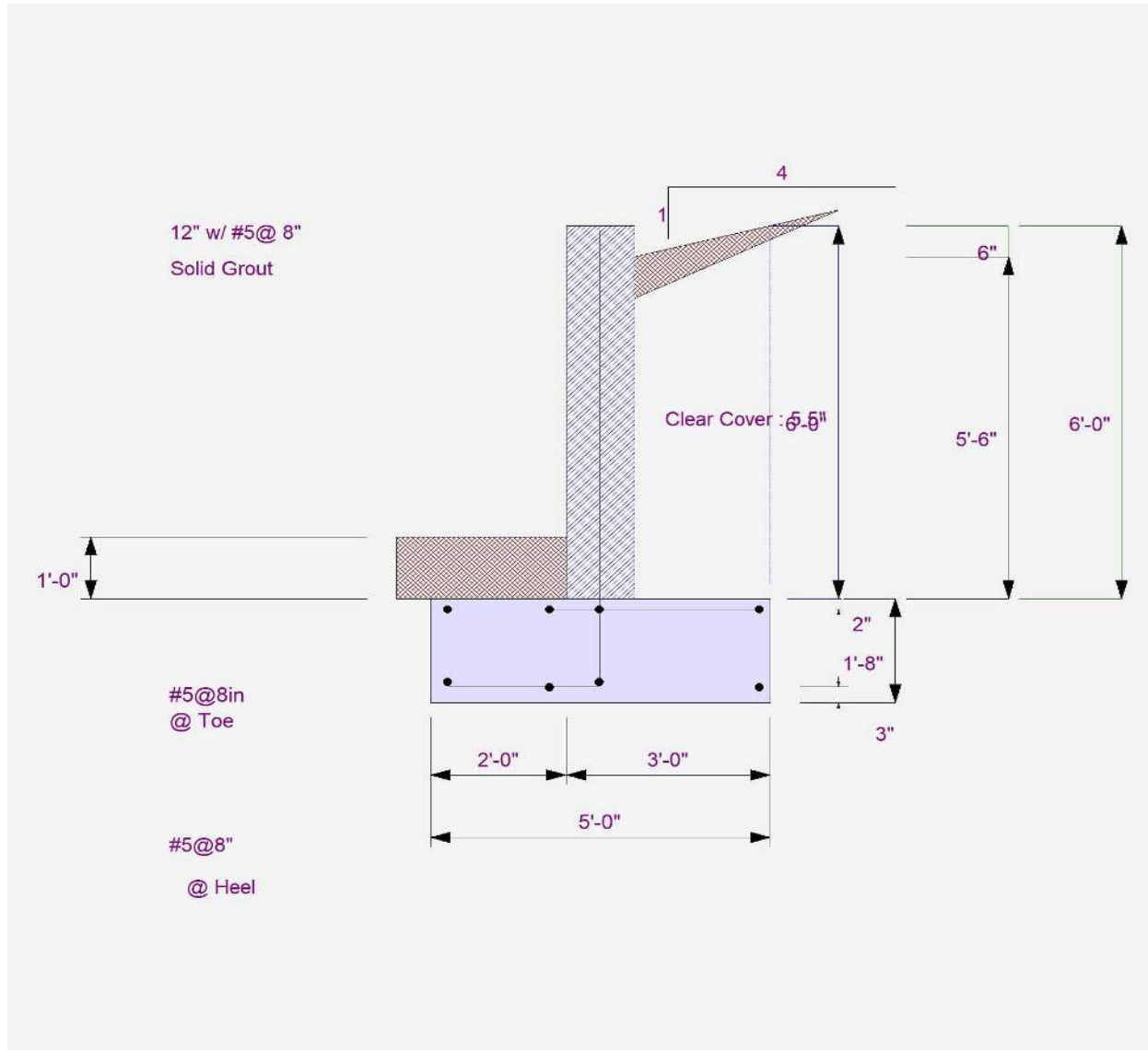

Cantilevered Retaining Wall

Project File: stallings.ec6

LIC# : KW-06015106, Build:20.24.09.03

CAROL CHADWICK, PE

(c) ENERCALC, LLC 1982-2024

DESCRIPTION: 6' wall CMU

FBC 2023, 8TH ED. - RESIDENTIAL

