

ROOF MOUNT PHOTOVOLTAIC SYSTEM

CODES:

THIS PROPOSED INSTALLATION COMPLIES WITH THE FOLLOWING:
 2023 8TH EDITION FLORIDA BUILDING CODE: BUILDING
 2023 8TH EDITION FLORIDA BUILDING CODE: RESIDENTIAL
 2023 8TH EDITION FLORIDA BUILDING CODE: MECHANICAL
 2023 8TH EDITION FLORIDA BUILDING CODE: PLUMBING
 2023 8TH EDITION FLORIDA BUILDING CODE: FUEL GAS
 2023 8TH EDITION FLORIDA BUILDING CODE: ENERGY CONSERVATION
 2023 8TH EDITION FLORIDA BUILDING CODE: EXISTING BUILDING
 2023 8TH EDITION FLORIDA BUILDING CODE: ACCESSIBILITY
 2023 8TH EDITION FLORIDA FIRE PREVENTION CODE (NFPA)
 2020 NATIONAL ELECTRIC CODE (NEC)
 AS ADOPTED BY COUNTY OF COLUMBIA

CONSTRUCTION NOTES:

CONDUIT AND CONDUCTOR SPECIFICATIONS ARE BASED ON MINIMUM CODE REQUIREMENTS AND ARE NOT MEANT TO LIMIT UP-SIZING AS REQUIRED BY FIELD CONDITIONS.

ALL SOLAR ENERGY SYSTEM EQUIPMENT SHALL BE SCREENED TO THE MAXIMUM EXTENT POSSIBLE AND SHALL BE PAINTED A COLOR SIMILAR TO THE SURFACE UPON WHICH THEY ARE MOUNTED.

MODULES SHALL BE TESTED , LISTED AND IDENTIFIED WITH FIRE CLASSIFICATION IN ACCORDANCE WITH UL 2703. SMOKE AND CARBON MONOXIDE ALARMS ARE REQUIRED PER SECTION R314 AND 315 TO BE VERIFIED AND INSPECTED BY INSPECTOR IN THE FIELD.

DIG ALERT (811) TO BE CONTACTED AND COMPLIANCE WITH EXCAVATION SAFETY PRIOR TO ANY EXCAVATION TAKING PLACE

PHOTOVOLTAIC SYSTEM GROUND WILL BE TIED INTO EXISTING GROUND AT MAIN SERVICE FROM DC DISCONNECT/INVERTER AS PER 2020 NEC SEC 250.166(A).

SOLAR PHOTOVOLTAIC SYSTEM EQUIPMENT WILL BE INSTALLED IN ACCORDANCE WITH REQUIREMENTS OF ART. 690 OF THE 2020 NEC

THE MAIN SERVICE PANEL WILL BE EQUIPPED WITH A GROUND ROD OR UFER

UTILITY COMPANY WILL BE NOTIFIED PRIOR TO ACTIVATION OF THE SOLAR PV SYSTEM

SOLAREEDGE OPTIMIZERS ARE LISTED TO IEC 62109-1 (CLASS II SAFETY) AND UL 1741 STANDARDS

INSTALL CREW TO VERIFY ROOF STRUCTURE PRIOR TO COMMENCING WORK. EMT CONDUIT ATTACHED TO THE ROOF USING CONDUIT MOUNT.

Taqi Khawaja



Digitally signed by
 Taqi Khawaja
 Date: 2024.09.20
 12:43:18 -07'00'

This item has been digitally signed and sealed by Taqi Khawaja, PE on 09/20/2024 using a Digital Signature. Printed copies of this document are not considered signed and sealed and the signatures must be verified on any electronic copies.

VICINITY MAP:

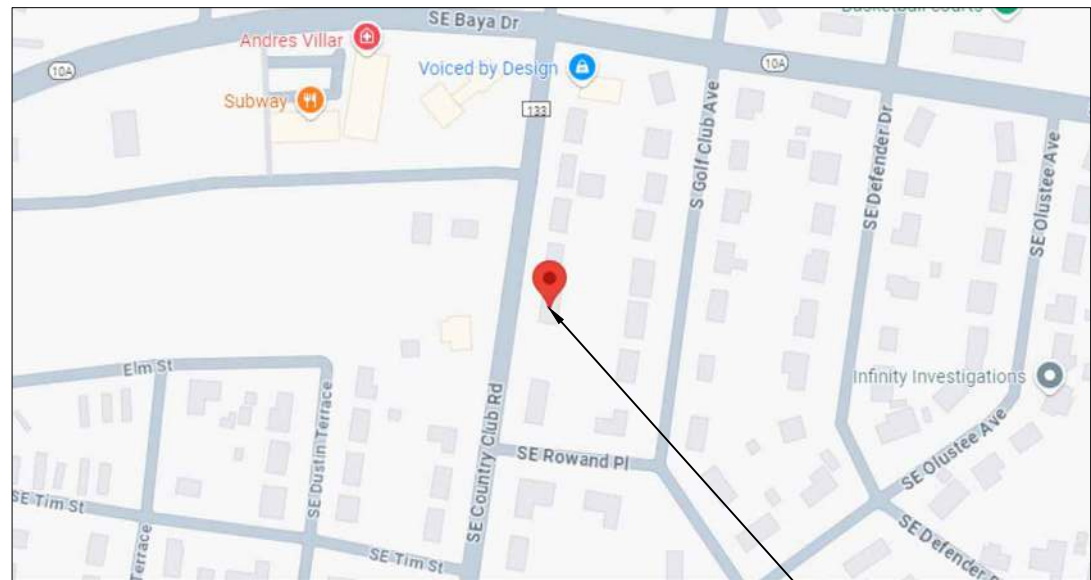

SITE LOCATION

THIS SYSTEM DESIGNED WITH:
 WIND SPEED: 119
 WIND EXPOSURE: C
 SNOW LOAD: 0

TABLE OF CONTENTS:

PV-1	PROJECT DETAILS
PV-2	SITE PLAN
PV-2A	ROOF PLAN WITH MODULES LAYOUT
PV-2B	ARRAY DETAILS
PV-3	MOUNTING DETAILS
PV-4	THREE LINE DIAGRAM
PV-5	CONDUCTOR CALCULATIONS
PV-6	EQUIPMENT & SERVICE LIST
PV-7	LABELS
PV-7A	SITE PLACARD
PV-8	OPTIMIZER CHART
PV-9	SAFETY PLAN
PV-10	SAFETY PLAN
APPENDIX	MANUFACTURER SPECIFICATION SHEETS

CLIENT:
 MICHAEL SCHLINK
 485 SOUTHEAST COUNTRY CLUB ROAD,
 LAKE CITY, FL 32025
 AHJ: COUNTY OF COLUMBIA
 UTILITY: FPL - FLORIDA POWER & LIGHT
 METER: ACD5917
 *PHONE:
 FINANCE: OTHER

SYSTEM:
 SYSTEM SIZE (DC): 16 X 430 = 6.880 kW
 SYSTEM SIZE (AC): 5.000 kW @ 240V
 MODULES: 16 X SILFAB SOLAR: SIL-430QD
 OPTIMIZERS: 16 X SOLAREEDGE S440
 INVERTER: SOLAREEDGE SE5000H-USRGM [S11]

REVISIONS		
NO.	REVISED BY	DATE
1	C.H.	9/19/2024
-	-	-
-	-	-













FREEDOM FOREVER LLC
 2619 CONSULATE DR SUITE 800, ORLANDO,
 FL 32819
 Tel: (800) 385-1075
GREG ALBRIGHT

CONTRACTOR LICENSE:
 CERTIFIED ELECTRICAL CONTRACTOR
 EC13008056

PROJECT DETAILS			
JOB NO:	DATE:	DESIGNED BY:	SHEET:
496653	9/19/2024	C.H.	PV-1

LEGEND:

-  CHIMNEY
-  PIPE VENT
-  MODULES
-  CONDUIT
-  SETBACK
-  AC DISCONNECT
-  UTILITY METER
-  JUNCTION BOX
-  INVERTER
-  MAIN SERVICE PANEL

PV SYSTEM
 6.880 kW-DC
 5.000 kW-AC

SOUTHEAST COUNTRY CLUB ROAD

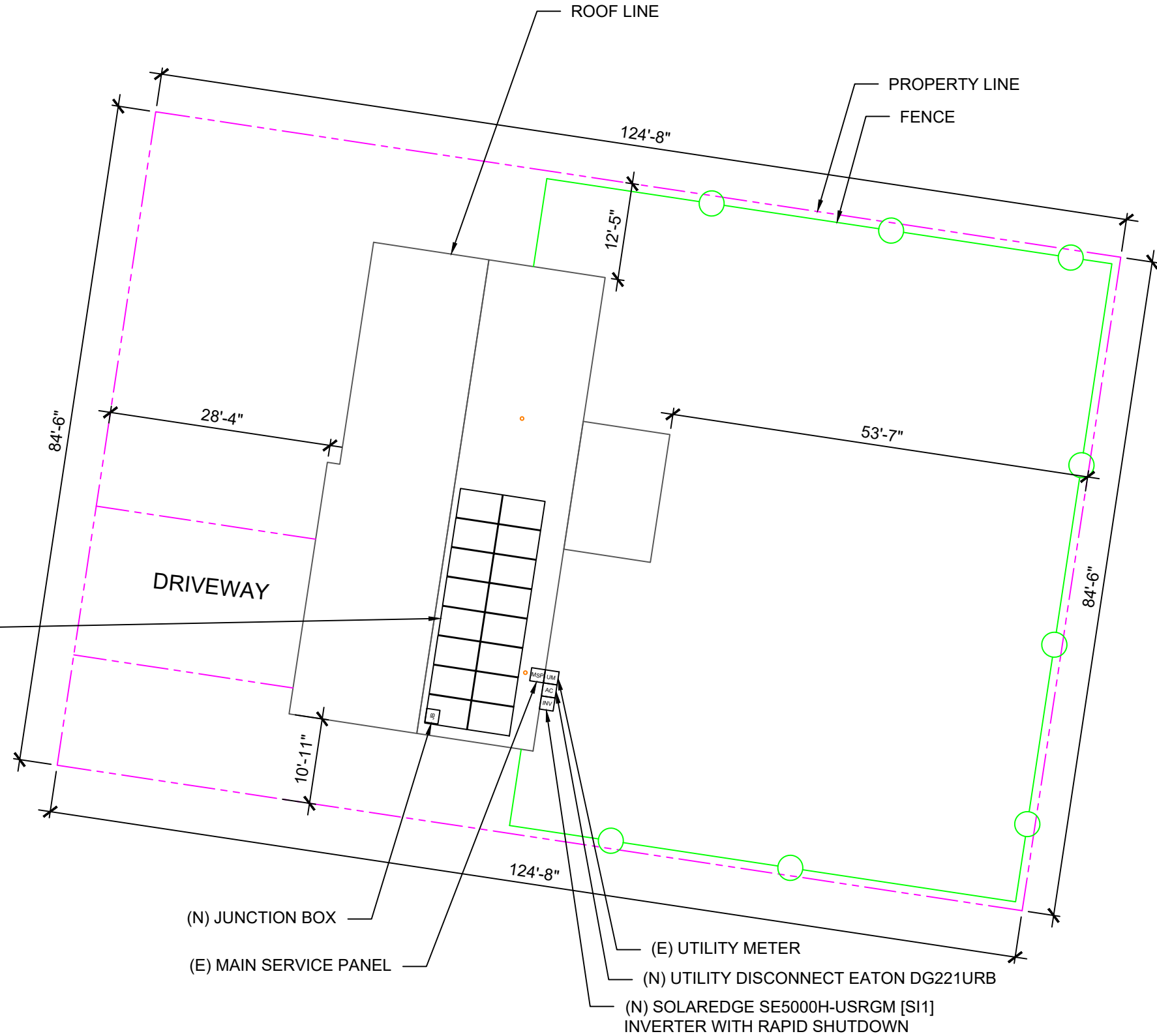

TOTAL ROOF AREA RIDGE SETBACK CALCS:
 TOTAL ROOF AREA: 2151.24 SQ FT
 SINGLE MODULE AREA: 20.98864825 SQ FT
 TOTAL NUMBER OF MODULES: 16
 TOTAL AREA OF MODULES: 335.82 SQ FT
 ROOF COVERAGE: 15.61%
 FIRE SPRINKLERS : NO

THIS SYSTEM DESIGNED WITH:
 WIND SPEED: 119
 WIND EXPOSURE: C
 SNOW LOAD: 0

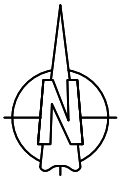

SITE PLAN
 SCALE: 1/16" = 1'-0"

1



This item has been digitally signed and sealed by Taqi Khawaja, PE on 09/20/2024 using a Digital Signature. Printed copies of this document are not considered signed and sealed and the signatures must be verified on any electronic copies.

ROOF AREA: 2151.24 SQ FT

CLIENT:
 MICHAEL SCHLINK
 485 SOUTHEAST COUNTRY CLUB ROAD,
 LAKE CITY, FL 32025
 AHJ: COUNTY OF COLUMBIA
 UTILITY: FPL - FLORIDA POWER & LIGHT
 METER: ACD5917
 *PHONE:
 FINANCE: OTHER

SYSTEM:
 SYSTEM SIZE (DC): 16 X 430 = 6.880 kW
 SYSTEM SIZE (AC): 5.000 kW @ 240V
 MODULES: 16 X SILFAB SOLAR: SIL-430QD
 OPTIMIZERS: 16 X SOLAREEDGE S440
 INVERTER: SOLAREEDGE SE5000H-USRGM [SI1]











REVISIONS		
NO.	REVISED BY	DATE
1	C.H.	9/19/2024
-	-	-
-	-	-

freedom
 FOREVER
 FREEDOM FOREVER LLC
 2619 CONSULATE DR SUITE 800, ORLANDO,
 FL 32819
 Tel: (800) 385-1075
 GREG ALBRIGHT

 CONTRACTOR LICENSE:
 CERTIFIED ELECTRICAL CONTRACTOR
 EC13008056

SITE PLAN			
JOB NO:	DATE:	DESIGNED BY:	SHEET:
496653	9/19/2024	C.H.	PV-2

LEGEND:

-  CHIMNEY
-  PIPE VENT
-  MODULES
-  CONDUIT
-  SETBACK
-  AC DISCONNECT
-  UTILITY METER
-  JUNCTION BOX
-  INVERTER
-  MAIN SERVICE PANEL

PV SYSTEM
6.880 kW-DC
 5.000 kW-AC

THIS SYSTEM DESIGNED WITH:
 WIND SPEED: 119
 WIND EXPOSURE: C
 SNOW LOAD: 0

TOTAL ROOF AREA: 2151.24 SQ FT
 TOTAL ARRAY AREA: 335.82 SQ FT
 ARRAY COVERAGE: 15.61%
 SYSTEM DISTRIBUTED WEIGHT: 2.71 LBS
 PROTEA POINT-LOAD: 13.23 LBS



ROOF PLAN
 SCALE: 1/8" = 1'-0"

1

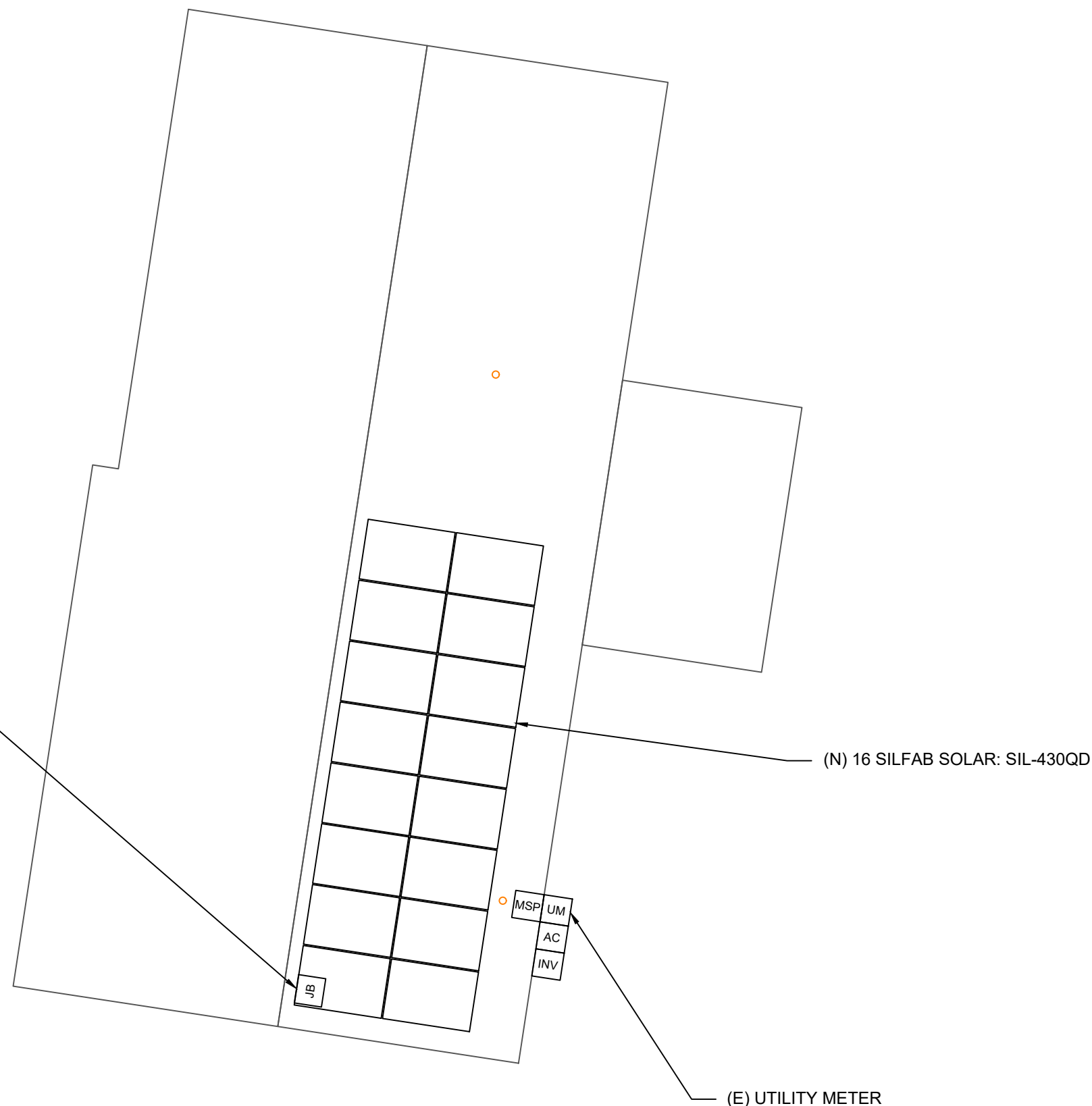

NOTES:

1. EMT CONDUIT ATTACHED TO THE ROOF USING CONDUIT MOUNTS
2. ATTACHED CLAMPS AT 25% FROM THE EDGE AND 50% FROM THE CENTER OF THE MODULES
3. JUNCTION BOX IS MOUNTED TO THE RAIL.



This item has been digitally signed and sealed by Taqi Khawaja, PE on 09/20/2024 using a Digital Signature. Printed copies of this document are not considered signed and sealed and the signatures must be verified on any electronic copies.

ROOF AREA: 2151.24 SQ FT

CLIENT:
 MICHAEL SCHLINK
 485 SOUTHEAST COUNTRY CLUB ROAD,
 LAKE CITY, FL 32025
 AHJ: COUNTY OF COLUMBIA
 UTILITY: FPL - FLORIDA POWER & LIGHT
 METER: ACD5917
 *PHONE:
 FINANCE: OTHER

SYSTEM:
 SYSTEM SIZE (DC): 16 X 430 = 6.880 kW
 SYSTEM SIZE (AC): 5.000 kW @ 240V
 MODULES: 16 X SILFAB SOLAR: SIL-430QD
 OPTIMIZERS: 16 X SOLAREEDGE S440
 INVERTER: SOLAREEDGE SE5000H-USRGM [S1]

REVISIONS		
NO.	REVISED BY	DATE
1	C.H.	9/19/2024
-	-	-
-	-	-



FREEDOM FOREVER LLC
 2619 CONSULATE DR SUITE 800, ORLANDO,
 FL 32819
 Tel: (800) 385-1075
 GREG ALBRIGHT

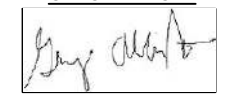

CONTRACTOR LICENSE:
 CERTIFIED ELECTRICAL CONTRACTOR
 EC13008056

ROOF PLAN WITH MODULES LAYOUT

JOB NO: 496653	DATE: 9/19/2024	DESIGNED BY: C.H.	SHEET: PV-2A
-------------------	--------------------	----------------------	-----------------

ROOF DETAILS:

TOTAL ROOF AREA: 2151.24 SQ FT
 TOTAL ARRAY AREA: 335.82 SQFT
 ARRAY COVERAGE: 15.61%
 SYSTEM DISTRIBUTED WEIGHT: 2.71 LBS
 PROTEA POINT-LOAD: 13.23 LBS



This item has been digitally signed and sealed by Taqi Khawaja, PE on 09/20/2024 using a Digital Signature. Printed copies of this document are not considered signed and sealed and the signatures must be verified on any electronic copies.

ROOF AREA STATEMENT						
ROOF	MODULE QUANTITY	ROOF PITCH	ARRAY PITCH	AZIMUTH	ROOF AREA	ARRAY AREA
ROOF 1	16	16	16	98.7	956.9 SQ FT	335.82 SQ FT
----	----	----	----	----	SQ FT	SQ FT
----	----	----	----	----	SQ FT	SQ FT
----	----	----	----	----	SQ FT	SQ FT
----	----	----	----	----	SQ FT	SQ FT
----	----	----	----	----	SQ FT	SQ FT
----	----	----	----	----	SQ FT	SQ FT
----	----	----	----	----	SQ FT	SQ FT
----	----	----	----	----	SQ FT	SQ FT
----	----	----	----	----	SQ FT	SQ FT

CLIENT:
 MICHAEL SCHLINK
 485 SOUTHEAST COUNTRY CLUB ROAD,
 LAKE CITY, FL 32025
 AHJ: COUNTY OF COLUMBIA
 UTILITY: FPL - FLORIDA POWER & LIGHT
 METER: ACD5917
 *PHONE:
 FINANCE: OTHER

SYSTEM:
 SYSTEM SIZE (DC): 16 X 430 = 6.880 kW
 SYSTEM SIZE (AC): 5.000 kW @ 240V
 MODULES: 16 X SILFAB SOLAR: SIL-430QD
 OPTIMIZERS: 16 X SOLAREEDGE S440
 INVERTER: SOLAREEDGE SE5000H-USRGM [S1]

REVISIONS		
NO.	REVISED BY	DATE
1	C.H.	9/19/2024
-	-	-
-	-	-



FREEDOM FOREVER LLC
 2619 CONSULATE DR SUITE 800, ORLANDO,
 FL 32819
 Tel: (800) 385-1075
 GREG ALBRIGHT

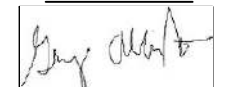

CONTRACTOR LICENSE:
 CERTIFIED ELECTRICAL CONTRACTOR
 EC13008056

ARRAY DETAILS			
JOB NO:	DATE:	DESIGNED BY:	SHEET:
496653	9/19/2024	C.H.	PV-2B

BACKFEED BREAKER SIZING					
MAX. CONTINUOUS OUTPUT 21.00A @ 240V					
21.00	X	1.25	=	26.25AMPS	30A BREAKER - OK
SEE 705.12 OF 2020 NEC					
200	X	1.20	=	240	
240	-	200	=	40A ALLOWABLE BACKFEED	

PV SYSTEM
6.880 kW-DC
 5.000 kW-AC



This item has been digitally signed and sealed by Taqi Khawaja, PE on 09/20/2024 using a Digital Signature. Printed copies of this document are not considered signed and sealed and the signatures must be verified on any electronic copies.

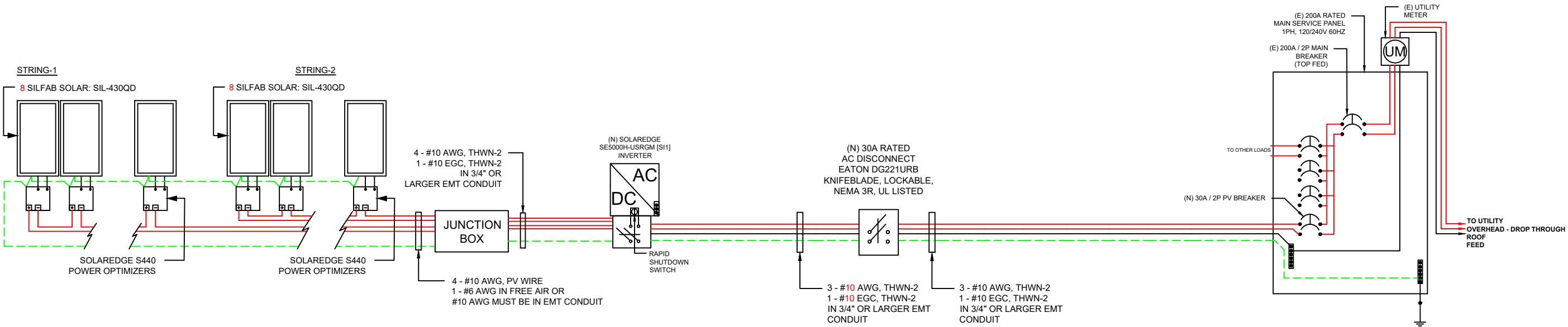

CLIENT:
 MICHAEL SCHLINK
 485 SOUTHEAST COUNTRY CLUB ROAD,
 LAKE CITY, FL 32025
 AHJ: COUNTY OF COLUMBIA
 UTILITY: FPL - FLORIDA POWER & LIGHT
 METER: ACD5917
 *PHONE:
 FINANCE: OTHER

SYSTEM:
 SYSTEM SIZE (DC): 16 X 430 = 6.880 kW
 SYSTEM SIZE (AC): 5.000 kW @ 240V
 MODULES: 16 X SILFAB SOLAR: SIL-430QD
 OPTIMIZERS: 16 X SOLAREEDGE S440
 INVERTER: SOLAREEDGE SE5000H-USRGM [S11]

REVISIONS		
NO.	REVISED BY	DATE
1	C.H.	9/19/2024
-	-	-
-	-	-



FREEDOM FOREVER LLC
 2619 CONSULATE DR SUITE 800, ORLANDO, FL 32819
 Tel: (800) 385-1075

GREG ALBRIGHT

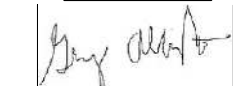

CONTRACTOR LICENSE:
 CERTIFIED ELECTRICAL CONTRACTOR
 EC13008056

NOTE:
 CONDUIT AND CONDUCTORS SPECIFICATIONS ARE BASED ON MINIMUM CODE REQUIREMENTS AND ARE NOT MEANT TO LIMIT UP-SIZING AS REQUIRED BY FIELD CONDITIONS

THREE LINE DIAGRAM

JOB NO: 496653	DATE: 9/19/2024	DESIGNED BY: C.H.	SHEET: PV-4
-------------------	--------------------	----------------------	----------------

MAIN PHOTOVOLTAIC SYSTEM DISCONNECT
690.13(B)

DO NOT DISCONNECT UNDER LOAD
NEC 690.15 (B) & NEC 690.33(D)(2)

WARNING
SINGLE 120-VOLT SUPPLY DO NOT CONNECT MULTIWIRED BRANCH CIRCUITS
NEC 710.15(C) & 692.9 (C)

WARNING DUAL POWER SOURCE
SECOND SOURCE IS PHOTOVOLTAIC SYSTEM
NEC 705.12(D) & NEC 690.59

WARNING
TURN OFF PHOTOVOLTAIC AC DISCONNECT PRIOR TO WORKING INSIDE PANEL
NEC 110.27(C) & OSHA 1910.145(F)(7)

WARNING
ELECTRICAL SHOCK HAZARD
TERMINALS ON THE LINE AND LOAD SIDES MAY BE ENERGIZED IN THE OPEN POSITION
706.15(C)(4) & 690.13(B)

WARNING
THIS EQUIPMENT FED BY MULTIPLE SOURCES: TOTAL RATING OF ALL OVERCURRENT DEVICES EXCLUDING MAIN POWER SUPPLY SHALL NOT EXCEED AMPACITY OF BUSBAR
NEC 705.12(B)(3)(3)

WARNING
THE DISCONNECTION OF THE GROUNDED CONDUCTOR(S) MAY RESULT IN OVERVOLTAGE ON THE EQUIPMENT
NEC 690.31(E)

RAPID SHUTDOWN SWITCH FOR SOLAR PV SYSTEM
690.56(C)(3)

If you have any questions about your system, please call our Customer Support Team at **888.557.6431** or visit freedomforever.com/customer-service



*Freedom Forever is a licensed contractor in all states it operates in. For more information visit freedomforever.com/forescan

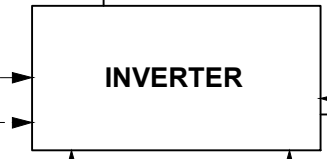
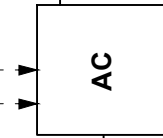
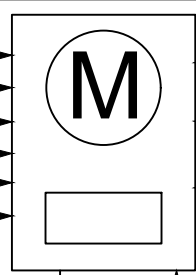

SOLAR PV SYSTEM EQUIPPED WITH RAPID SHUTDOWN

TURN RAPID SHUTDOWN SWITCH TO THE "OFF" POSITION TO SHUT DOWN PV SYSTEM AND REDUCE SHOCK HAZARD IN THE ARRAY

CAUTION
PHOTOVOLTAIC SYSTEM CIRCUIT IS BACKFED
NEC 705.12(D) & NEC 690.59

WARNING
POWER SOURCE OUTPUT CONNECTION. DO NOT RELOCATE THIS OVERCURRENT DEVICE.
NEC 705.12(C) & NEC 690.59

WARNING
ARC FLASH AND SHOCK HAZARD APPROPRIATE PPE REQUIRED
24 INCH FLASH HAZARD BOUNDARY
3 CALCMF2 FLASH HAZARD AT 18 INCHES
480 VAC SHOCK HAZARD WHEN COVER IS REMOVED
42 INCH LIMITED APPROACH
12 INCH RESTRICTED APPROACH - 500 V CLASS 00 GLOVES
1 INCH PROHIBITED APPROACH - 500 V CLASS 00 GLOVES
LOCATION: 485 SOUTHEAST COUNTRY CLUB ROAD LAKE CITY, FL 32025

PHOTOVOLTAIC AC DISCONNECT
NEC 690.13(B)

PHOTOVOLTAIC AC DISCONNECT
RATED AC OUTPUT CURRENT: **21.00A**
NOMINAL OPERATING AC VOLTAGE: **240V**
NEC 690.54

SOLAR PV DC CIRCUIT
EVERY 10' ON CONDUIT AND ENCLOSURES
NEC 690.31

PHOTOVOLTAIC POWER SOURCE
EVERY 10' ON CONDUIT AND ENCLOSURES
NEC 690.31(D)(2)

MAXIMUM VOLTAGE **480** V
MAXIMUM CIRCUIT CURRENT **13.5** A
MAX DC-DC CONVERTER OUTPUT CURRENT **15** A

NOTES:

- NEC ARTICLES 690 AND 705 AND IRC SECTION R324 MARKINGS SHOWN HEREON.
- ALL MARKING SHALL CONSIST OF THE FOLLOWING:
 - UV RESISTANT SIGN MATERIAL WITH ENGRAVED OR MACHINE PRINTED LETTERS OR ELECTRO-PLATING.
 - RED BACKGROUND COLOR WHITE TEXT AND LINE WORK.
 - ARIAL FONT.
- ALL SIGNS SHALL BE SIZED APPROPRIATELY AND PLACED IN THE LOCATIONS SPECIFIED. SIGNAGE CANNOT BE HAND-WRITTEN.
- SIGNS SHALL BE ATTACHED TO THE SERVICE EQUIPMENT WITH POP-RIVETS OR SCREWS



This item has been digitally signed and sealed by Taqi Khawaja, PE on 09/20/2024 using a Digital Signature. Printed copies of this document are not considered signed and sealed and the signatures must be verified on any electronic copies.

PHOTOVOLTAIC DC DISCONNECT
NEC 690.13(B)

MAXIMUM DC VOLTAGE OF PV SYSTEM
NEC 690.53

WARNING
ELECTRICAL SHOCK HAZARD
TERMINALS ON THE LINE AND LOAD SIDES MAY BE ENERGIZED IN THE OPEN POSITION
DC VOLTAGE IS ALWAYS PRESENT WHEN SOLAR MODULES ARE EXPOSED TO SUNLIGHT
706.15(C)(4) & 690.13(B)

WARNING
ELECTRICAL SHOCK HAZARD
TERMINALS ON THE LINE AND LOAD SIDES MAY BE ENERGIZED IN THE OPEN POSITION
706.15(C)(4) & 690.13(B)

WARNING
TURN OFF PHOTOVOLTAIC AC DISCONNECT PRIOR TO WORKING INSIDE PANEL
NEC 110.27(C) & OSHA 1910.145(F)(7)

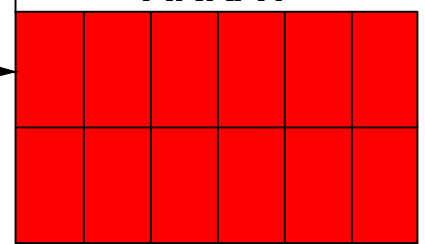

NEC 690.31(G)(3) & (4)

CLIENT:
MICHAEL SCHLINK
485 SOUTHEAST COUNTRY CLUB ROAD,
LAKE CITY, FL 32025
AHJ: COUNTY OF COLUMBIA
UTILITY: FPL - FLORIDA POWER & LIGHT
METER: ACD5917
PHONE:
FINANCE: OTHER

SYSTEM:
SYSTEM SIZE (DC): 16 X 430 = 6.880 kW
SYSTEM SIZE (AC): 5.000 kW @ 240V
MODULES: 16 X SILFAB SOLAR: SIL-430QD
OPTIMIZERS: 16 X SOLAREEDGE S440
INVERTER: SOLAREEDGE SE5000H-USRGM [S11]

REVISIONS		
NO.	REVISED BY	DATE
1	C.H.	9/19/2024
-	-	-
-	-	-



FREEDOM FOREVER LLC
2619 CONSULATE DR SUITE 800, ORLANDO, FL 32819
Tel: (800) 385-1075
GREG ALBRIGHT

Greg Albright

CONTRACTOR LICENSE:
CERTIFIED ELECTRICAL CONTRACTOR
EC13008056

LABELS			
JOB NO:	DATE:	DESIGNED BY:	SHEET:
496653	9/19/2024	C.H.	PV-7

CAUTION:

POWER TO THIS BUILDING IS ALSO SUPPLIED FROM THE FOLLOWING SOURCES WITH DISCONNECTS AS SHOWN

SOUTHEAST COUNTRY CLUB ROAD

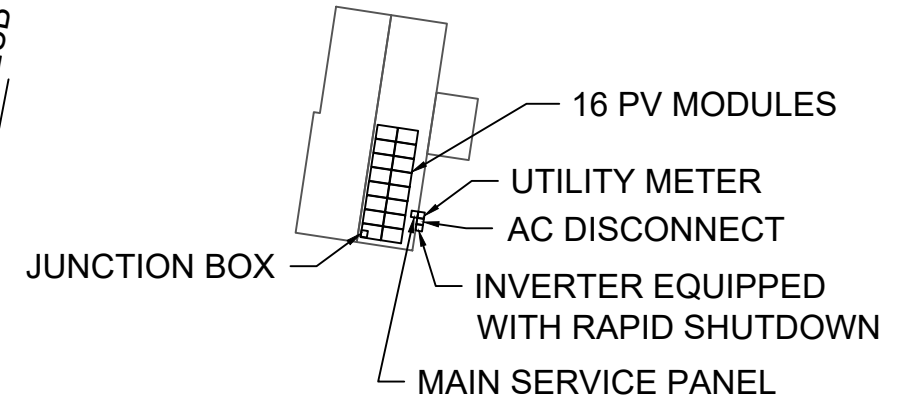

WARNING

TURN OFF PHOTOVOLTAIC AC DISCONNECT PRIOR TO WORKING INSIDE PANEL



This item has been digitally signed and sealed by Taqi Khawaja, PE on 09/20/2024 using a Digital Signature. Printed copies of this document are not considered signed and sealed and the signatures must be verified on any electronic copies.

CLIENT:
MICHAEL SCHLINK
485 SOUTHEAST COUNTRY CLUB ROAD,
LAKE CITY, FL 32025
AHJ: COUNTY OF COLUMBIA
UTILITY: FPL - FLORIDA POWER & LIGHT
METER: ACD5917
*PHONE:
FINANCE: OTHER

SYSTEM:
SYSTEM SIZE (DC): 16 X 430 = 6.880 kW
SYSTEM SIZE (AC): 5.000 kW @ 240V
MODULES: 16 X SILFAB SOLAR: SIL-430QD
OPTIMIZERS: 16 X SOLAREEDGE S440
INVERTER: SOLAREEDGE SE5000H-USRGM [S1]

REVISIONS		
NO.	REVISED BY	DATE
1	C.H.	9/19/2024
-	-	-
-	-	-



FREEDOM FOREVER LLC
2619 CONSULATE DR SUITE 800, ORLANDO,
FL 32819
Tel: (800) 385-1075
GREG ALBRIGHT

Greg Albright

CONTRACTOR LICENSE:
CERTIFIED ELECTRICAL CONTRACTOR
EC13008056

SITE PLACARD			
JOB NO:	DATE:	DESIGNED BY:	SHEET:
496653	9/19/2024	C.H.	PV-7A

NOTES:

1. NEC ARTICLES 690 AND 705 AND IRC SECTION R324 MARKINGS SHOWN HEREON.
2. ALL MARKING SHALL CONSIST OF THE FOLLOWING:
 - A. UV RESISTANT SIGN MATERIAL WITH ENGRAVED OR MACHINE PRINTED LETTERS OR ELECTRO-PLATING.
 - B. RED BACKGROUND COLOR WHITE TEXT AND LINE WORK.
 - C. AERIAL FONT.
3. ALL SIGNS SHALL BE SIZED APPROPRIATELY AND PLACED IN THE LOCATIONS SPECIFIED. SIGNAGE CANNOT BE HAND-WRITTEN.
4. SIGNS SHALL BE ATTACHED TO THE SERVICE EQUIPMENT WITH POP-RIVETS OR SCREWS.

1-10 11-20 21-30 31-40 41-50 51-60

SOLAREEDGE OPTIMIZER CHART

1

2

3

4

5

6

7

8

9

10

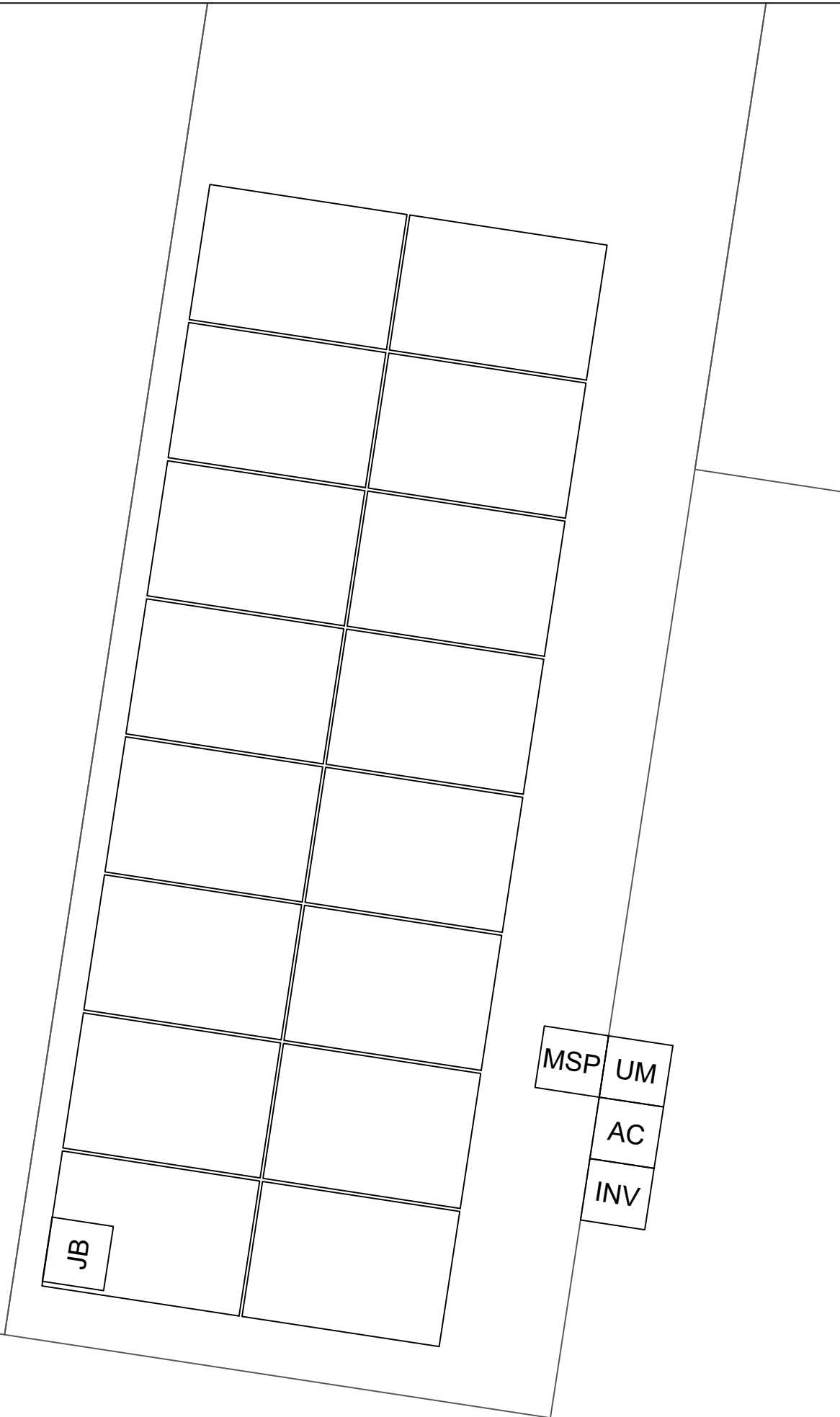

CLIENT:
 MICHAEL SCHLINK
 485 SOUTHEAST COUNTRY CLUB ROAD,
 LAKE CITY, FL 32025
 AHJ: COUNTY OF COLUMBIA
 UTILITY: FPL - FLORIDA POWER & LIGHT
 METER: ACD5917
 *PHONE:
 FINANCE: OTHER

SYSTEM:
 SYSTEM SIZE (DC): 16 X 430 = 6.880 kW
 SYSTEM SIZE (AC): 5.000 kW @ 240V
 MODULES: 16 X SILFAB SOLAR: SIL-430QD
 OPTIMIZERS: 16 X SOLAREEDGE S440
 INVERTER: SOLAREEDGE SE5000H-USRGM [S1]

REVISIONS		
NO.	REVISED BY	DATE
1	C.H.	9/19/2024
-	-	-
-	-	-



FREEDOM FOREVER LLC
 2619 CONSULATE DR SUITE 800, ORLANDO, FL 32819

Tel: (800) 385-1075

GREG ALBRIGHT

CONTRACTOR LICENSE:
 CERTIFIED ELECTRICAL CONTRACTOR
 EC13008056

OPTIMIZER CHART

JOB NO: 496653	DATE: 9/19/2024	DESIGNED BY: C.H.	SHEET: PV-8
-------------------	--------------------	----------------------	----------------

JOB HAZARD ANALYSIS

Crew leader to fill out all sections below, hold a pre-job safety meeting with all personnel, and upload this completed document and the Safety Plan to Site Capture

Ladder Access

- Ladders must be inspected before each use.
- Extension ladders must be set up on a firm and level surface at a 4-to-1 rise to run angle (or 75 degrees) and the top must be secured to the structure. Extension style ladders placed on uneven, loose or slippery surfaces must additionally have the base firmly anchored or lashed so the base will not slip out.
- Extension ladders must be used with walk-through devices or the ladder must extend 36" above the stepping off point.
- A-frame ladders must only be climbed with the ladder spreader bars locked in the open position; A-frame ladders shall not be climbed while in the closed position (ex, closed and used while leaned against a structure).

Additional notes:

Mobile Equipment

- Only Qualified operators will operate equipment; operators must maintain a certification on their person for the equipment being operated.
- Type(s) of mobile equipment (Type/Make/Model):
- Qualified operator(s):

Material Handling and Storage

- Materials will be staged/stored in a way that does not present a hazard to client, personnel or public. Materials stored on the roof will be physically protect from failing or sliding off.

Fall Protection

- A site-specific plan for fall prevention and protection is required prior to starting work and must remain onsite at all times until work is complete; a fall rescue plan must be outlined and discussed among the crew prior to work start.
- First-person-Up (FPU) must install their anchor and connect before any other task, including installing other anchors. The Last-Person-Down (LPD) must be the only person on a roof uninstalling fall protection.

FPCP (name and title):

FPU and LPD (name and title):

Electrical Safety

- The Electrical Qualified Person (EQP) is required onsite to perform electrical work.
- All electrical work will be performed with equipment in an electrically safe condition (de-energized) unless approval has been granted prior to work.
- Service drops and overhead electrical hazards will be identified and protected from contact, as necessary.

EQP (name and title):

Public Protection

- The safety of the Client and Public must be maintained at all times.
- The Client and the Public shall be prevented from entering the work zone through the use of barriers and/or signage, as required.
- Company, Client and Public property shall be protected from falling objects.
- Pets (including dogs) shall be secured by their owners prior to work start.
- The Client should not leave pets, family members, or others in charge or care of Employees, Contractors, or Temporary Workers.

Crew leader responsible for communication with the client:

Client and public is excluded from work area by barricades (N/A, Yes, No):

Training and Pre-Job Safety Briefing

- All employees onsite shall be made aware of the specific hazards of this project and review this HJA during a pre-job briefing, and their signature indicates awareness of site conditions and the plan to eliminate any hazards identified prior to and during the project.

Crew leader (name/title):

Crew member (name/title):

Crew member (name/title):

Crew member (name/title):

Crew member (name/title):

Crew member (name/title):

Airborne Contaminants:

- Asbestos-containing (Transite) piping (ACP) - Do not disturb (move, drill, cut fracture, etc.)
- Asbestos-containing thermal insulation (ACI) and Asbestos-containing duct wrapping (ACW) - do not disturb, no attic or crawlspace access is allowed if work to be performed could cause exposure to personnel, client or public.

If yes, list specific tasks and protection in place:

Weather and Environment

- The site supervisor shall forecast the weather conditions at the job site, prior to crew arrival, in order to mitigate any hazards associated with inclement weather (heat, cold, wind, rain, etc.)
- The site supervisor will utilized a portable wind meter (anemometer) to verify actual onsite wind conditions, by checking at the ground and on any elevated work surface (ex, rooftop) prior to work start, at midday and prior to solar panel staging on a roof.
- Elevated work involving the moving or maneuvering of solar panels shall cease at 25mph (sustained wind) until wind subsides.

Forecasted weather maximum temp (degrees f):

Heat Related Illness Prevention

- Employees shall have access to potable drinking water that is fresh, pure, and suitably cool. The water shall be located as close as practicable to the areas where employees are working. Water shall be supplied in sufficient quantity at the beginning of the work shift to provide at least one quart per employee per hour for drinking for the entire shift. Employees may begin the shift with smaller quantities of water if they identify the location and have effective means for replenishment during the shift to allow employees to drink on quart or more per hour. The frequent drinking of water shall be encouraged.
- Shade shall be present when temperature exceeds 80 degrees Fahrenheit. When the outdoor temperature in the work exceeds 80 degrees Fahrenheit, employees shall have and maintain one or more areas with shade at all times.
- New employees must be acclimatized. New employees will be monitored by their Crew Leader (site supervisor) for the first two (2) weeks of employment or longer when necessary.
- Employees will be allowed and encouraged to implement scheduled breaks during each shift. Employees must take cool-down breaks in the shade any time they feel the need to do so to protect them from overheating. Supervisors are REQUIRED to allow employees any break period they need during high heat conditions.
- Cool Vests are encouraged for all employees at all times during periods of high heat.
- Identify the location of the closet Occupational/Industrial Clinic or Hospital in case a crew member becomes ill.

What is the specific plan to provide and replenish sufficient water for all employees on site?

If offsite replenish is necessary, where will you go to replenish water (location/address):

Who will replenish the drinking water (name):

Restroom facilities

- Employees shall have access to restroom facilities with hand-washing stations. Use of onsite restroom is at the client's discretion (location is annotated below). If client does not give permission, location of suitable restroom facilities with hand-washing stations offsite will be provided. The onsite supervisor will identify location and make arrangements to ensure all employees have access at any point.

Restroom facilities will be (circle one): Onsite - Offsite

If Offsite, add location name and address:

Incident Reporting Procedure

Contact your Site Supervisor

Name:

Phone:

Contact your Manager

Name:

Phone:

Contact your Site Supervisor

Name:

Phone:

With: Your full name, phone number, office location, brief description of what happen and when.

NOTE ADDITIONAL HAZARDS NOT ADDRESSED ABOVE

(add as many as necessary by using additional sheets)

Define the Hazard:	Method/steps to prevent incident:
Define the Hazard:	Method/steps to prevent incident:
Define the Hazard:	Method/steps to prevent incident:
Define the Hazard:	Method/steps to prevent incident:

CLIENT:
 MICHAEL SCHLINK
 485 SOUTHEAST COUNTRY CLUB ROAD,
 LAKE CITY, FL 32025
 AHJ: COUNTY OF COLUMBIA
 UTILITY: FPL - FLORIDA POWER & LIGHT
 METER: ACD5917
 *PHONE:
 FINANCE: OTHER

SYSTEM:
 SYSTEM SIZE (DC): 16 X 430 = 6.880 kW
 SYSTEM SIZE (AC): 5.000 kW @ 240V
 MODULES: 16 X SILFAB SOLAR: SIL-430QD
 OPTIMIZERS: 16 X SOLAREEDGE S440
 INVERTER: SOLAREEDGE SE5000H-USRGM [SI1]

REVISIONS		
NO.	REVISED BY	DATE
1	C.H.	9/19/2024
-	-	-
-	-	-



FREEDOM FOREVER LLC
 2619 CONSULATE DR SUITE 800, ORLANDO,
 FL 32819
 Tel: (800) 385-1075
GREG ALBRIGHT

Greg Albright

CONTRACTOR LICENSE:
 CERTIFIED ELECTRICAL CONTRACTOR
 EC13008056

SAFETY PLAN

JOB NO:	DATE:	DESIGNED BY:	SHEET:
496653	9/19/2024	C.H.	PV-10

FOR INSTALLATION REFERENCE ONLY

SCAN QR CODE TO ACCESS REFERENCE LINK

FREEDOM REFERENCES



INSTALL HOTLINE

PV INSTALLATION REFERENCES



ENPHASE



SOLAREEDGE



TESLA

BATTERY INSTALLATION REFERENCES



Enphase Storage Systems



SOLAREEDGE Storage Systems



TESLA Storage Systems



NON-BACKUP Battery Systems



Misc. Quick Guide

SILFAB PRIME NTC

SIL-430 QD

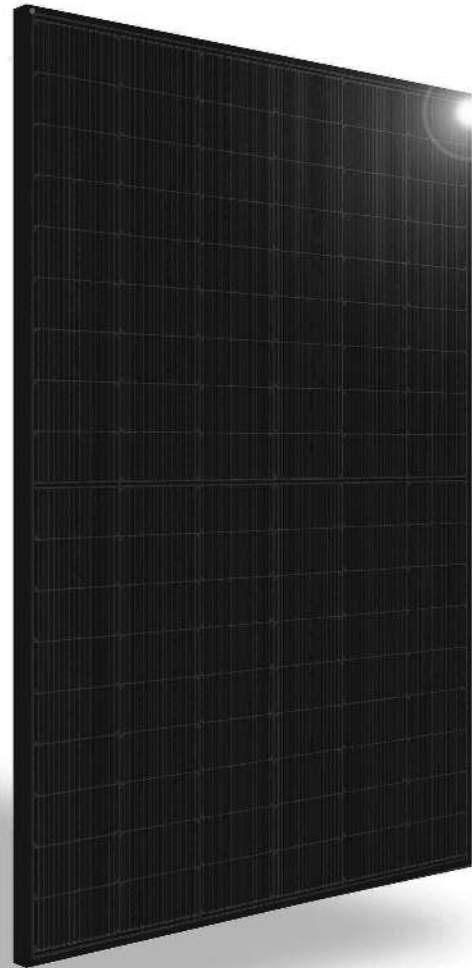

INTRODUCING NEXT-GENERATION N-TYPE CELL TECHNOLOGY

- Improved Shade Tolerance
- Improved Low-Light Performance
- Increased Performance in High Temperatures
- Enhanced Durability
- Reduced Degradation Rate
- Industry-Leading Warranty



SILFABSOLAR.COM



ELECTRICAL SPECIFICATIONS		430	
Test Conditions		STC	NOCT
Module Power (Pmax)	Wp	430	321
Maximum power voltage (Vpmax)	V	33.25	31.02
Maximum power current (Ipmax)	A	12.93	10.33
Open circuit voltage (Voc)	V	38.91	36.58
Short circuit current (Isc)	A	13.87	11.15
Module efficiency	%	22.1%	20.6%
Maximum system voltage (VDC)	V		1000
Series fuse rating	A		25
Power Tolerance	Wp		0 to +10

Measurement conditions: STC 1000 W/m² • AM 1.5 • Temperature 25 °C • NOCT 800 W/m² • AM 1.5 • Measurement uncertainty ≤ 3%
Sun simulator calibration reference modules from Fraunhofer Institute. Electrical characteristics may vary by ±5% and power by 0 to +10 W.

MECHANICAL PROPERTIES / COMPONENTS	METRIC	IMPERIAL
Module weight	21 kg ± 0.2 kg	46.3 lbs ± 0.4 lbs
Dimensions (H x L x D)	1721 mm x 1133 mm x 35 mm	67.8 in x 44.6 in x 1.37 in
Maximum surface load (wind/snow)*	4000 Pa rear load / 5400 Pa front load	83.5 lb/ft ² rear load / 112.8 lb/ft ² front load
Hail impact resistance	ø 25 mm at 83 km/h	ø 1 in at 51.6 mph
Cells	108 Half cells - N-Type Silicon solar cell 182 mm x 91 mm	108 Half cells - N-Type Silicon solar cell 7.16 in x 3.58 in
Glass	3.2 mm high transmittance, tempered, antireflective coating	0.126 in high transmittance, tempered, antireflective coating
Cables and connectors (refer to installation manual)	1350 mm, ø 5.7 mm, MC4 from Staubli	53.1 in, ø 0.22 in (12 AWG), MC4 from Staubli
Backsheet	High durability, superior hydrolysis and UV resistance, multi-layer dielectric film, fluorine-free PV backsheet	
Frame	Anodized aluminum (Black)	
Junction Box	UL 3730 Certified, IEC 62790 Certified, IP68 rated, 3 diodes	

TEMPERATURE RATINGS		WARRANTIES	
Temperature Coefficient Isc	0.04 %/°C	Module product workmanship warranty	25 years**
Temperature Coefficient Voc	-0.24 %/°C	Linear power performance guarantee	30 years
Temperature Coefficient Pmax	-0.29 %/°C		≥ 98% end 1st yr ≥ 94.7% end 12th yr ≥ 90.8% end 25th yr ≥ 89.3% end 30th yr
NOCT (± 2 °C)	45 °C		
Operating temperature	-40/+85 °C		

CERTIFICATIONS		SHIPPING SPECS	
Product	UL 61215, UL 61730, CSA C22.2#61730, IEC 61215, IEC 61730, IEC 61701 (Salt Mist Corrosion), IEC 62716 (Ammonia Corrosion), CEC Listed, UL Fire Rating: Type 2	Modules Per Pallet:	26 or 26 (California)
Factory	ISO9001:2015	Pallets Per Truck	32 or 30 (California)
		Modules Per Truck	832 or 780 (California)

* ⚠ Warning. Read the Safety and Installation Manual for mounting specifications and before handling, installing and operating modules.
** 12 year extendable to 25 years subject to registration and conditions outlined under "Warranty" at silfabsolar.com.
PAN files generated from 3rd party performance data are available for download at: silfabsolar.com/downloads.

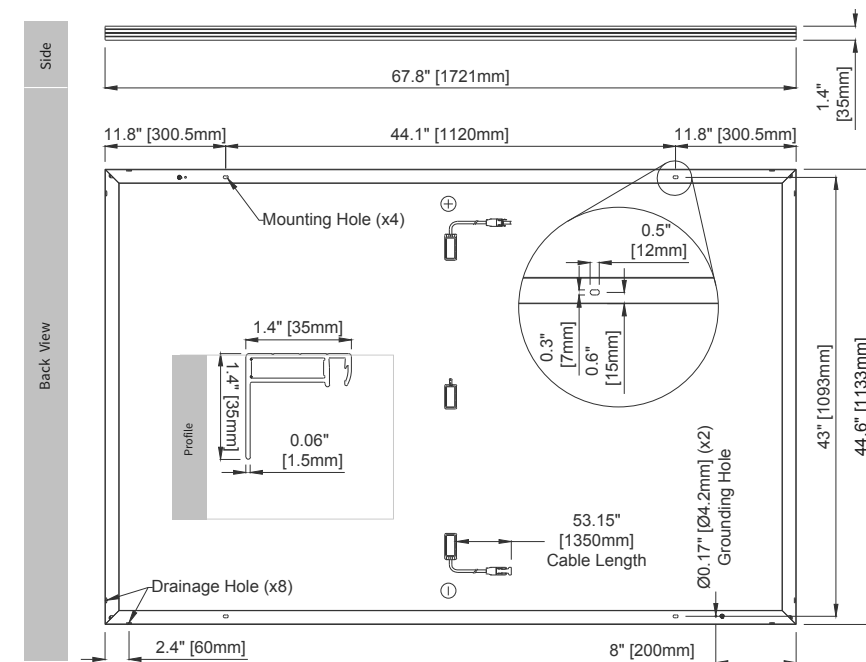

SILFAB SOLAR INC.

1770 Port Drive
Burlington WA 98233 USA
T +1 360.569.4733
info@silfabsolar.com
SILFABSOLAR.COM

7149 Logistics Lane
Fort Mill SC 29715 USA
T +1 839.400.4338

240 Courtneypark Drive East
Mississauga ON L5T 2Y3 Canada
T +1 905.255.2501
F +1 905.696.0267

Silfab - SIL-430-QD-20240227
No reproduction of any kind is allowed without permission.
Data and information is subject to modifications without notice. © Silfab Solar Inc., 2022. Silfab Solar® is a registered trademark of Silfab Solar Inc.

SolarEdge Home Wave Inverter For North America

SE3800H-US / SE5000H-US / SE6000H-US /
SE7600H-US / SE10000H-US / SE11400H-US

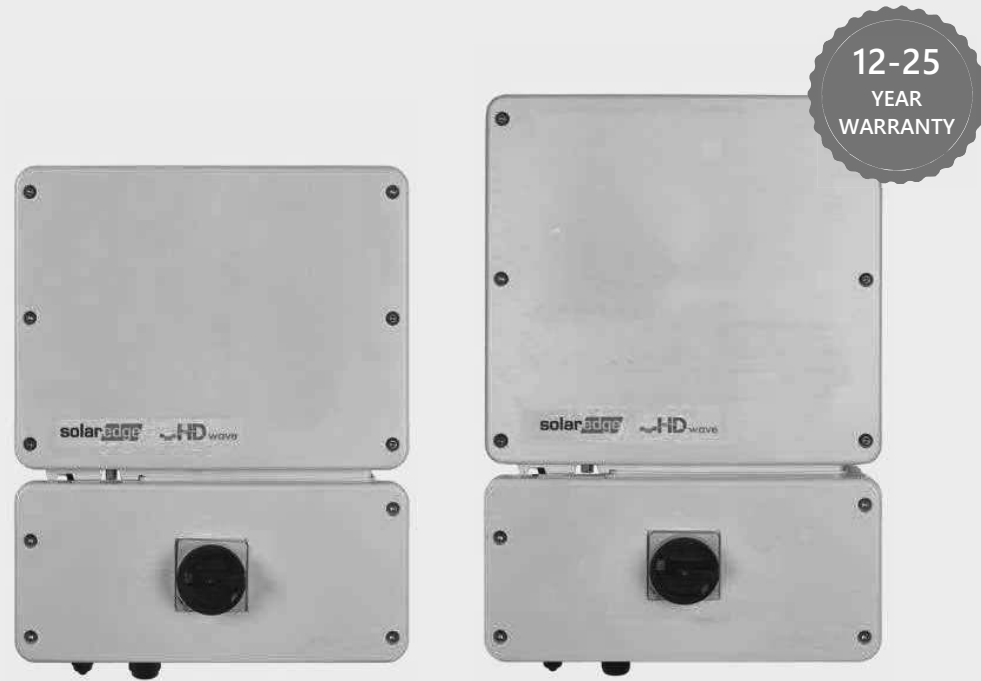

INVERTERS

Optimized installation with HD-Wave technology

- Specifically designed to work with power optimizers
- Record-breaking 99% weighted efficiency
- Quick and easy inverter commissioning directly from a smartphone using SolarEdge SetApp
- Fixed voltage inverter for longer strings
- Integrated arc fault protection and rapid shutdown for NEC 2014-2023 per articles 690.11 and 690.12
- UL1741 SA certified, for CPUC Rule 21 grid compliance
- Small, lightweight, and easy to install both outdoors or indoors
- Built-in module-level monitoring
- Optional: Faster installations with built-in consumption metering (1% accuracy) and production revenue grade metering (0.5% accuracy, ANSI C12.20)

/ SolarEdge Home Wave Inverter For North America

SE3800H-US / SE5000H-US / SE6000H-US /
SE7600H-US / SE10000H-US / SE11400H-US

Applicable to inverters with part number	SEXXXXH-XXXXBXX4					SE11400H-XXXXBXX5	Units
	SE3800H-US	SE5000H-US	SE6000H-US	SE7600H-US	SE10000H-US	SE11400H-US	
OUTPUT							
Rated AC Power Output	3800 @ 240V 3300 @ 208V	5000	6000 @ 240V 5000 @ 208V	7600	10000	11400 @ 240V 10000 @ 208V	VA
Maximum AC Power Output	3800 @ 240V 3300 @ 208V	5000	6000 @ 240V 5000 @ 208V	7600	10000	11400 @ 240V 10000 @ 208V	VA
AC Output Voltage Min.-Nom.-Max. (211 - 240 - 264)	✓	✓	✓	✓	✓	✓	Vac
AC Output Voltage Min.-Nom.-Max. (183 - 208 - 229)	✓	-	✓	-	-	✓	Vac
AC Frequency (Nominal)	59.3 - 60 - 60.5 ⁽¹⁾						Hz
Maximum Continuous Output Current @240V	16	21	25	32	42	47.5	A
Maximum Continuous Output Current @208V	16	-	24	-	-	48.5	A
Power Factor	1, Adjustable - 0.85 to 0.85						
GFDI Threshold	1						A
Utility Monitoring, Islanding Protection, Country Configurable Thresholds	Yes						
INPUT							
Maximum DC Power @240V	5900	7750	9300	11800	15500	17650	W
Maximum DC Power @208V	5100	-	7750	-	-	15500	W
Transformer-less, Ungrounded	Yes						
Maximum Input Voltage	480						Vdc
Nominal DC Input Voltage	380						Vdc
Maximum Input Current @240V ⁽²⁾	10.5	13.5	16.5	20	27	30.5	Adc
Maximum Input Current @208V ⁽²⁾	9	-	13.5	-	-	27	Adc
Max. Input Short Circuit Current	45						Adc
Reverse-Polarity Protection	Yes						
Ground-Fault Isolation Detection	600k Sensitivity						
Maximum Inverter Efficiency	99.2						%
CEC Weighted Efficiency	99					99 @ 240V 98.5 @ 208V	%
Nighttime Power Consumption	< 2.5						W

(1) For other regional settings please contact SolarEdge support.
(2) A higher current source may be used; the inverter will limit its input current to the values stated.

/ SolarEdge Home Wave Inverter

For North America

SE3800H-US / SE5000H-US / SE6000H-US/

SE7600H-US / SE10000H-US / SE11400H-US

Applicable to inverters with part number	SEXXXXH-XXXXXBXX4					SE11400H-XXXXXBXX5	
	SE3800H-US	SE5000H-US	SE6000H-US	SE7600H-US	SE10000H-US	SE11400H-US	
ADDITIONAL FEATURES							
Supported Communication Interfaces	RS485, Ethernet, ZigBee (optional), wireless SolarEdge Home Network (optional) ⁽³⁾ , Wi-Fi (optional), Cellular (optional)						
Revenue Grade Metering, ANSI C12.20	Optional ⁽⁴⁾						
Consumption Metering							
Inverter Commissioning	With the SetApp mobile application using Built-in Wi-Fi Access Point for Local Connection						
Rapid Shutdown - NEC 2014-2023 per articles 690.11 and 690.12	Automatic Rapid Shutdown upon AC Grid Disconnect						
STANDARD COMPLIANCE							
Safety	UL1741, UL1741 SA, UL1741 SB, UL1699B, CSA C22.2, Canadian AFCI according to T.I.L. M-07						
Grid Connection Standards	IEEE1547-2018, Rule 21, Rule 14 (H1), CSA C22.3 No. 9						
Emissions	FCC Part 15 Class B						
INSTALLATION SPECIFICATIONS							
AC Output Conduit Size / AWG Range	1" Maximum / 14 – 6 AWG			1" Maximum / 14 – 4 AWG			
DC Input Conduit Size / # of Strings / AWG Range	1" Maximum / 1 – 2 strings / 14 – 6 AWG			1" Maximum / 1 – 3 strings / 14 – 6 AWG			
Dimensions with Safety Switch (H x W x D)	17.7 x 14.6 x 6.8 / 450 x 370 x 174			21.06 x 14.6 x 7.3 / 535 x 370 x 185	21.06 x 14.6 x 8.2 / 535 x 370 x 208 ⁽⁵⁾		in / mm
Weight with Safety Switch	22 / 10	25.1 / 11.4	26.2 / 11.9	38.8 / 17.6	44.9 / 20.4 ⁽⁵⁾		lb / kg
Noise	< 25			< 50			dBA
Cooling	Natural Convection						
Operating Temperature Range	-40 to +140 / -40 to +60 ⁽⁶⁾						°F / °C
Protection Rating	NEMA 4X (Inverter with Safety Switch)						

(3) For more information, refer to the [SolarEdge Home Network](#) datasheet

(4) Inverter with Revenue Grade Production and Consumption Meter P/N: SExxxxH-US000BEI4. For consumption metering, current transformers should be ordered separately: SEACT0750-400NA-20 or SEACT0750-400NA-20. 20 units per box.

(5) SE11400H-USxxxBox5 is the updated PN, though SE11400H-USxxxBox4 will still be available. All specifications are similar for both models, **EXCLUDING** the weight and dimensions [HxWxD]. The weight and dimensions of SE11400H-USxxxBox4 are 17.6 [kg] and 21.06-14.6-7.3 / 535-370-185 [in/mm], accordingly.

(6) Full power up to at least 50°C / 122°F; for power de-rating information refer to the [Temperature De-rating Technical Note for North America](#).

How to Enable Consumption Monitoring

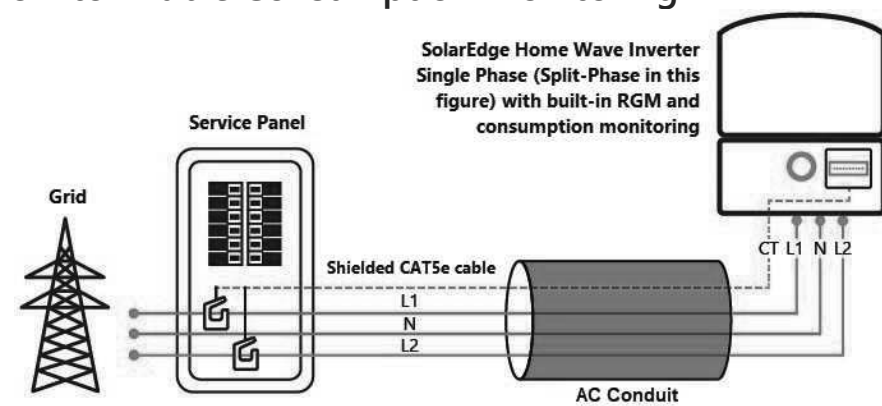

By simply wiring current transformers through the inverter's existing AC conduits and connecting them to the service panel, homeowners will gain full insight into their household energy usage helping them to avoid high electricity bills.

Power Optimizer For North America

S440, S500



25
YEAR
WARRANTY

POWER OPTIMIZER

PV power optimization at the module level

- Specifically designed to work with SolarEdge residential inverters
- Detects abnormal PV connector behavior, preventing potential safety issues*
- Module-level voltage shutdown for installer and firefighter safety
- Superior efficiency (99.5%)
- Mitigates all types of module mismatch loss, from manufacturing tolerance to partial shading
- Faster installations with simplified cable management and easy assembly using a single bolt
- Flexible system design for maximum space utilization
- Compatible with bifacial PV modules
- Meets NEC requirements for arc fault protection (AFCI) and Photovoltaic Rapid Shutdown System (PVRSS)

* Expected availability in 2022

solaredge.com



/ Power Optimizer For North America S440, S500

	S440	S500	Unit
INPUT			
Rated Input DC Power ⁽¹⁾	440	500	W
Absolute Maximum Input Voltage (Voc)	60		Vdc
MPPT Operating Range	8 - 60		Vdc
Maximum Short Circuit Current (Isc) of Connected PV Module	14.5	15	Adc
Maximum Efficiency	99.5		%
Weighted Efficiency	98.6		%
Oversvoltage Category	II		
OUTPUT DURING OPERATION			
Maximum Output Current	15		Adc
Maximum Output Voltage	60		Vdc
OUTPUT DURING STANDBY (POWER OPTIMIZER DISCONNECTED FROM INVERTER OR INVERTER OFF)			
Safety Output Voltage per Power Optimizer	1+/-0.1		Vdc
STANDARD COMPLIANCE			
Photovoltaic Rapid Shutdown System	NEC 2014, 2017 & 2020		
EMC	FCC Part 15 Class B, IEC61000-6-2, IEC61000-6-3		
Safety	IEC62109-1 (class II safety), UL1741		
Material	UL94 V-0, UV Resistant		
RoHS	Yes		
Fire Safety	VDE-AR-E 2100-712:2013-05		
INSTALLATION SPECIFICATIONS			
Maximum Allowed System Voltage	1000		Vdc
Dimensions (W x L x H)	129 x 153 x 30 / 5.07 x 6.02 x 1.18		mm / in
Weight (including cables)	655 / 1.5		gr / lb
Input Connector	MC4 ⁽²⁾		
Input Wire Length	0.1 / 0.32		m / ft
Output Connector	MC4		
Output Wire Length	(+) 2.3, (-) 0.10 / (+) 7.54, (-) 0.32		m / ft
Operating Temperature Range ⁽³⁾	-40 to +85		°C
Protection Rating	IP68 / Type6B		
Relative Humidity	0 - 100		%

(1) Rated power of the module at STC will not exceed the power optimizer Rated Input DC Power. Modules with up to +5% power tolerance are allowed.
 (2) For other connector types please contact SolarEdge.
 (3) For ambient temperature above +70°C / +158°F power de-rating is applied. Refer to Power Optimizers Temperature De-Rating Technical Note for more details.

PV System Design Using a SolarEdge Inverter	Single Phase HD-Wave	Three Phase for 208V grid	Three Phase for 277/480V grid	
Minimum String Length (Power Optimizers)	S440, S500	8	14	18
Maximum String Length (Power Optimizers)	25		50 ⁽⁴⁾	
Maximum Nominal Power per String	5700 (6000 with SE7600-US-SE11400-U)	6000	12750	W
Maximum Allowed Connected Power per String ⁽⁵⁾ (Permitted only when the difference in connected power between strings is 1,000W or less)	Refer to Footnote 5	One String 7200W Two strings or more 7800W	15,000W	
Parallel Strings of Different Lengths or Orientations	Y			

(4) A string with more than 30 optimizers does not meet NEC rapid shutdown requirements; safety voltage will be above the 30V requirement.
 (5) If the inverters rated AC power < maximum nominal power per string, then the maximum power per string will be able to reach up to the inverters maximum input DC power. Refer to: <https://www.solaredge.com/sites/default/files/se-power-optimizer-single-string-design-application-note.pdf>
 (6) It is not allowed to mix S-series and P-series Power Optimizers in new installations.

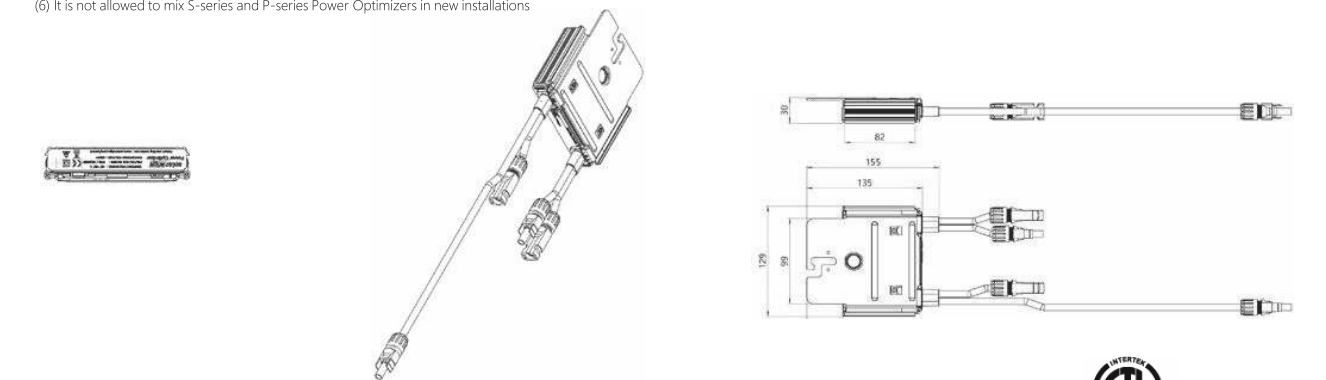

© SolarEdge Technologies, Inc. All rights reserved. SOLAREEDGE, the SolarEdge logo, OPTIMIZED BY SOLAREEDGE are trademarks or registered trademarks of SolarEdge Technologies, Inc. All other trademarks mentioned herein are trademarks of their respective owners. Date: February 8, 2022 DS-000018-NA. Subject to change without notice.



Product specifications

Eaton DG221URB

Catalog Number: DG221URB

Eaton General duty non-fusible safety switch, single-throw, 30 A, 240 V, NEMA 3R, Rainproof, Painted galvanized steel, Two-pole, Two-wire

General specifications

Product Name	Catalog Number
Eaton general duty non-fusible safety switch	DG221URB
	UPC
	782113120232
Product Length/Depth	Product Height
6.88 in	10.81 in
Product Width	Product Weight
6.38 in	6 lb
Warranty	Certifications
Eaton Selling Policy 25-000, one (1) year from the date of installation of the Product or eighteen (18) months from the date of shipment of the Product, whichever occurs first.	UL Listed
	Catalog Notes
	WARNING! Switch is not approved for service entrance unless a neutral kit is installed.



Product specifications

Product Category
General duty safety switch
Enclosure material
Painted galvanized steel
Type
Non-fusible, single-throw
Fuse configuration
Non-fusible
Number of wires
2
Enclosure
NEMA 3R
Voltage rating
240V
Amperage Rating
30A
Number Of Poles
Two-pole

Resources

Catalogs
Eaton's Volume 2—Commercial Distribution
Multimedia
Double Up on Safety
Switching Devices Flex Center
Specifications and datasheets
Eaton Specification Sheet - DG221URB



Eaton Corporation plc
Eaton House
30 Pembroke Road
Dublin 4, Ireland
Eaton.com
© 2023 Eaton. All Rights Reserved.

Eaton is a registered trademark.

All other trademarks are property of their respective owners.



Eaton.com/socialmedia

The right way to attach solar PV to trapezoidal roof profiles!

S-5![®] The Right Way![™]

ProteaBracket[™]

A versatile bracket for mounting solar PV to trapezoidal roof profiles

ProteaBracket[™] is now made in aluminum. Still the most versatile trapezoidal metal roof attachment solution on the market, the S-5! ProteaBracket just got better!

The bracket features an adjustable attachment base and module attachment options to accommodate different roof profile dimensions and mounting options.

Our pre-applied EPDM gasket with peel and stick adhesive makes installation a snap, ensuring accurate and secure placement the first time.

With no messy sealants, faster installation, and a weather-proof fit, ProteaBracket offers you the most versatile solar attachment solution available.

ProteaBracket* can be used for rail mounting or "direct-attach" with S-5! PVKIT[™]

*When ProteaBracket is used in conjunction with the S-5! PVKIT, an additional nut is required during installation.

NOW AVAILABLE
IN ALUMINUM



Features and Benefits

- 34% lighter - saves on shipping
- Stronger L-Foot[™]
- Load-tested for engineered application
- Corrosion-resistant materials
- Adjustable - Fits rib profiles up to 3"
- Peel-and-Stick prevents accidental shifting during installation
- Fully pre-assembled
- 25-year warranty*

*See www.S-5.com for details.



ProteaBracket[™]



888-825-3432 | www.S-5.com

S-5![®] The Right Way![™]

ProteaBracket[™] is the perfect solar attachment solution for most trapezoidal rib, exposed-fastened metal roof profiles!

ProteaBracket[™] is compatible with common metal roofing materials and comes with a pre-applied EPDM gasket on the base.

Note: All four pre-punched holes must be used to achieve tested strength. Fasteners are provided.

For design assistance, ask your distributor, or visit www.S-5.com for the independent lab test data that can be used for load-critical designs and applications. Also, please visit our website for more information including metallurgical compatibilities and specifications.

S-5![®] holding strength is unmatched in the industry.

Multiple Attachment Options:

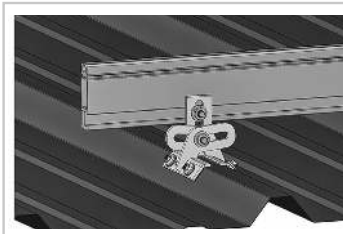

Side
Mount Rail

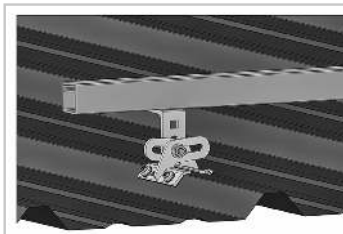

Bottom
Mount Rail



w/ S-5!
PVKIT[™]
(rail-less)

ProteaBracket[™]

ProteaBracket[™] is still available in stainless steel.

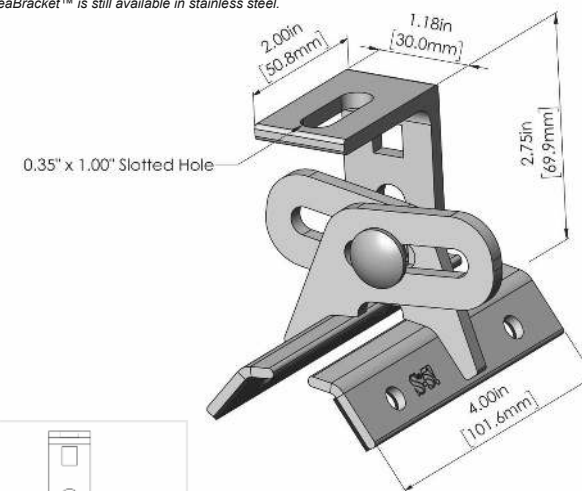

ProteaBracket fits profiles up to 3 inches

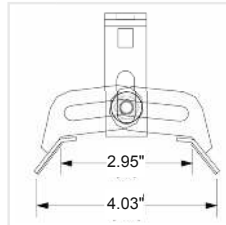

INSTALLATION:

- No surface preparation needed.** (1) Wipe away excess oil and debris. (2) Peel off adhesive release paper. (3) Align and mount bracket directly onto crown of panel. (4) Secure ProteaBracket through pre-punched holes, using piercing-point S-5! screws.



ProteaBracket[™] and the S-5! PVKIT[™] 2.0 mounted on a trapezoidal roof profile

S-5![®] Warning! Please use this product responsibly!

Products are protected by multiple U.S. and foreign patents. For published data regarding holding strength, bolt torque, patents, and trademarks, visit the S-5! website at www.S-5.com.

Copyright 2019, Metal Roof Innovations, Ltd. S-5! products are patent protected. S-5! aggressively protects its patents, trademarks, and copyrights. Version 07089.

Distributed by

NXT HORIZON®

UNIRAC®
BETTER SOLAR STARTS HERE

UNIRAC
25
YEAR
FULL-SYSTEM
WARRANTY

DISCOVER YOUR NXT HORIZON®

The culmination of over two decades of experience. Thoughtful design, rigorous engineering, world-class support, and a reliable supply chain are the foundation of what makes us confident that NXT HORIZON® is the NXT Level of DESIGN, SIMPLICITY, and VALUE.

NXT HORIZON® COMBO CLAMP

DARK: CCLAMPD1
MILL: CCLAMPM1

Clicks into rail anywhere (even where there are cables!)
Self-standing clamp with spring combines as both mid and end clamp.
Clamps 30-40 mm modules

STRONGHOLD™ RAIL CLAMP

DARK: SHCLMPD1
MILL: SHCLMPM1

Adaptable rail connection to attachments allows click-in feature compatibility with almost all of Unirac's attachments.

1/2 inch module spacing for efficiency.

Unirac-quality bonding that works both as mid and end clamps.

NXT HORIZON CAP KIT

ENDCAPD1

Make the install look clean with the end cap kit designed to complement the module end clamp and rail ends.

STRONGHOLD® ATTACHMENT KIT

DARK: SHCPKTD1
MILL: SHCPKTM1

Rail clicks into the clamps attached to the Stronghold™ base. Open slot in L-foot allows drop-in rail clamp.

Alternative attachment options:

NXT HORIZON® RAIL

DARK: 168RLD1
MILL: 168RLM1

Strong, lightweight open channel rail with invisible, easy, unfalling and integrated wire management system.

NXT HORIZON® RAIL SPLICE

RLSPLCM1

Structural internal splice that does not interfere with roof connection nor module connection. Pre-assembled thread cutting bolts.

WIRE MANAGEMENT OPTIONS

NXT HORIZON® MLPE & LUG CLAMP

LUGMLPE1

Works as either MLPE Mount or Grounding Lug connection to the rail. Why source two parts when one can do the job?

NXT HORIZON® WIRE MANAGEMENT CLIP

WRMCLPD1

Aesthetic, yet functional accessory that works to help installers keep wires inside the rail. No zip-ties required. Optional zip tie loop for extra wire management capabilities!

NXT HORIZON® NORTH/SOUTH WIRE MANAGEMENT CLIP

WRMCNSD1

An elegant solution to help installers get to the home run. The same hardware works to provide both easy entry to rail and adjustability for cable thickness.

ALL NXT HORIZON® SYSTEMS INCLUDE A FREE PERMITTING PLANSET DESIGN - FOR QUESTIONS OR CUSTOMER SERVICE VISIT UNIRAC.COM OR EMAIL NXTPERMITS@UNIRAC.COM



Certificate: 70131735
Project: 80182385

Master Contract: 266909
Date Issued: 2023-11-29

Downward Design Load (lb/ft ²)	33.9
Upward Design Load (lb/ft ²)	33.9
Down-Slope Load (lb/ft ²)	16.5

Model	NXT UMount	-	Flush-to-Roof is an extruded aluminum rail PV racking system that is installed parallel to the roof in landscape or portrait orientations.
-------	------------	---	--

NXT UMount

The system listed is designed to provide bonding/grounding, and mechanical stability for photovoltaic modules. The system is secured to the roof with the L-Foot components through the roofing material to building structure. Modules are secured to the racking system with aluminum mid clamps and aluminum end clamps. The modules are bonded to the racking system with bonding mid and end clamps with piercing points. Fire ratings of Class A with Type 1, 2, 3 (with metallic frame), 10(with metallic frame), 19, 22, 25, 29, or 30 for steep and low slope. Tested at 5" interstitial gap which allows installation at any stand-off height.

The grounding of the system is intended to comply with the latest edition of the National Electrical Code, to include NEC 250 & 690. Local codes compliance is required, in addition to national codes. All grounding/bonding connections are to be torqued in accordance with the Installation Manual and the settings used during the certification testing for the current edition of the project report.

Latest Install Manual revision: PUB2023NOV10

UL 2703 Mechanical Load ratings for tested module area 21.86 sq ft:

NXT Systems without DTD Butyl Attachment P30817211, Rail Splice P30808218, or Rail Clamp P30817214	
Downward Design Load (lb/ft²)	113.7
Upward Design Load (lb/ft²)	51.1
Down-Slope Load (lb/ft²)	16.8

NXT Systems with DTD Butyl Attachment P30817211, Rail Splice P30808218, or Rail Clamp P30817214	
Downward Design Load (lb/ft²)	51.1
Upward Design Load (lb/ft²)	51.1



Certificate: 70131735
Project: 80182385

Master Contract: 266909
Date Issued: 2023-11-29

Down-Slope Load (lb/ft²)	16.8
--	------

UL 2703 and TIL Mechanical Load ratings tested module area 27.76 sq ft:

NXT Systems without DTD Butyl Attachment P30817211, Rail Splice P30808218, or Rail Clamp P30817214	
Downward Design Load (lb/ft²)	50.1
Upward Design Load (lb/ft²)	22.2
Down-Slope Load (lb/ft²)	8.0

NXT Systems with DTD Butyl Attachment P30817211, Rail Splice P30808218, or Rail Clamp P30817214	
Downward Design Load (lb/ft²)	39.47
Upward Design Load (lb/ft²)	22.2
Down-Slope Load (lb/ft²)	8.0

UL 2703 and TIL Mechanical Load ratings tested module area 29.49 sq ft:

NXT Systems with all components included in PUB2023NOV10 Install Manual	
Downward Design Load (lb/ft²)	37.06
Upward Design Load (lb/ft²)	20.97
Down-Slope Load (lb/ft²)	7.53

Model	SM Ascender	-	One or two row elevated or non-elevated roof system is an extruded aluminum rail PV racking system that is installed to the roof in portrait orientation.
-------	-------------	---	---

SM Ascender

The system listed is designed to provide bonding/grounding, and mechanical stability for photovoltaic modules. The system is secured to the roof with the L-Foot components through the roofing material to building structure. Modules are secured to the racking system with aluminum mid clamps and aluminum end clamps. Fire rating of Class A when installed over non-combustible roofing materials.

