



STRUCTURAL DESIGN **ENCLOSED BUILDING**

**MAXIMUM 30'-0" WIDE X 20'-0" EAVE HEIGHT-
BOX EAVE FRAME AND BOW FRAME**

11 December 2020

Revision 9

M&A Project No.

16062S/16155S/16207S/17155S/17200S/18068S/18156S/18290S/20019S/20324S

Prepared for:

Steel Buildings and Structures, Inc.

P.O. Box 1287

Mt. Airy, NC 27030

Prepared by:

**Moore and Associates Engineering
and Consulting, Inc.**

**1009 East Avenue
North Augusta, SC 29841**





**401 S. Main St., Suite 200
Mt. Airy, NC 27030**

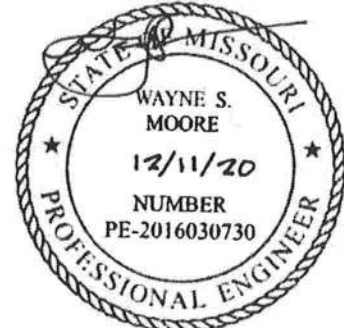

MOORE AND ASSOCIATES
ENGINEERING AND CONSULTING

		<p>I HAVE RESEARCHED THIS CHAPTER AND THE LOUISIANA STATE UNIFORM CONSTRUCTION CODE AND TO THE BEST OF MY KNOWLEDGE AND BELIEF, THESE DRAWINGS ARE IN COMPLIANCE THEREWITH. I TAKE FULL RESPONSIBILITY FOR THE CONTENTS OF THESE PLANS.</p>	

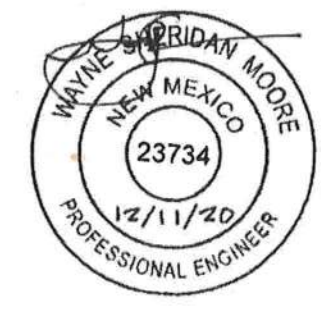
<p>MOORE AND ASSOCIATES ENGINEERING AND CONSULTING, INC.</p>		<p>DRAWN BY: LT CHECKED BY: PDH</p>		<p>STEEL BUILDINGS AND STRUCTURES, INC. P.O. BOX 1287, MOUNT AIRY, NC 27030 30'-0" x 20'-0" ENCLOSED STRUCTURE</p>	
<p>THIS DOCUMENT IS THE PROPERTY OF MOORE AND ASSOCIATES ENGINEERING AND CONSULTING. THE UNAUTHORIZED REPRODUCTION, COPYING, OR OTHERWISE USE OF THIS DOCUMENT IS STRICTLY PROHIBITED AND ANY INFRINGEMENT THEREUPON MAY BE SUBJECT TO LEGAL ACTION.</p>		<p>PROJECT MGR: WSM</p>	<p>DATE: 12-11-20</p>	<p>SCALE: NTS</p>	<p>JOB NO: 18068S/18156S 18290S/20019S/20324S</p>
<p>CLIENT: SBSI</p>		<p>SHT. 1</p>	<p>DWG. NO: SK-3</p>	<p>REV: 9</p>	

	<p>Professional Certification. I hereby certify that these documents were prepared or approved by me, and that I am a duly licensed professional engineer under the laws of the State of Maryland, License No. 49744, Expiration Date <u>6/6/22</u></p>		
			
			
			
			

<p align="center">MOORE AND ASSOCIATES ENGINEERING AND CONSULTING, INC.</p> <p><small>THIS DOCUMENT IS THE PROPERTY OF MOORE AND ASSOCIATES ENGINEERING AND CONSULTING. THE UNAUTHORIZED REPRODUCTION, COPYING, OR OTHERWISE USE OF THIS DOCUMENT IS STRICTLY PROHIBITED AND ANY INFRINGEMENT THEREUPON MAY BE SUBJECT TO LEGAL ACTION.</small></p>	<p>DRAWN BY: LT</p>	<p align="center">STEEL BUILDINGS AND STRUCTURES, INC. P.O. BOX 1287, MOUNT AIRY, NC 27030 30'-0" x 20'-0" ENCLOSED STRUCTURE</p>		
	<p>CHECKED BY: PDH</p>	<p>PROJECT MGR: WSM</p>	<p>DATE: 12-11-20</p>	<p>SCALE: NTS</p>
<p>CLIENT: SBSI</p>	<p>SHT. 1A</p>	<p>DWG. NO: SK-3</p>	<p>REV: 9</p>	

DRAWING INDEX

SHEET 1	PE SEAL COVER SHEET (1 OF 2)
SHEET 1A	PE SEAL COVER SHEET (2 OF 2)
SHEET 2	DRAWING INDEX
SHEET 3	INSTALLATION NOTES AND SPECIFICATIONS
SHEET 4	TYPICAL SIDE AND END ELEVATIONS
SHEET 5	TYPICAL RAFTER/COLUMN FRAME AND SIDE FRAMING SECTION (BOX EAVE STRUCTURE)
SHEET 5A	TYPICAL RAFTER/COLUMN FRAME AND SIDE FRAMING SECTION (BOX EAVE STRUCTURE)
SHEET 5B	TYPICAL RAFTER/COLUMN FRAME AND SIDE FRAMING SECTION (BOX EAVE STRUCTURE)
SHEET 6	COLUMN CONNECTION DETAILS (BOX EAVE STRUCTURE)
SHEET 6A	COLUMN CONNECTION DETAILS (BOX EAVE STRUCTURE)
SHEET 7	TYPICAL RAFTER/COLUMN FRAME AND SIDE FRAMING SECTION (BOW EAVE STRUCTURE)
SHEET 7A	TYPICAL RAFTER/COLUMN FRAME AND SIDE FRAMING SECTION (BOW EAVE STRUCTURE)
SHEET 7B	TYPICAL RAFTER/COLUMN FRAME AND SIDE FRAMING SECTION (BOW EAVE STRUCTURE)
SHEET 8	COLUMN CONNECTION DETAILS (BOW EAVE STRUCTURE)
SHEET 8A	COLUMN CONNECTION DETAILS (BOW EAVE STRUCTURE)
SHEET 9	BASE RAIL ANCHORAGE OPTIONS
SHEET 9A	ADDITIONAL BASE RAIL ANCHORAGE OPTION
SHEET 10	BOX EAVE RAFTER END WALL AND SIDE WALL OPENINGS
SHEET 11	BOW EAVE RAFTER END WALL AND SIDE WALL OPENINGS
SHEET 12	CONNECTION DETAILS
SHEET 13	CONNECTION DETAILS
SHEET 14	BOX EAVE RAFTER LEAN-TO OPTIONS
SHEET 15	BOW EAVE RAFTER LEAN-TO OPTIONS
SHEET 16	VERTICAL ROOF/SIDING OPTION END AND SIDE ELEVATION AND SECTION
SHEET 17	SIDE WALL AND END WALL HEADER OPTIONS
SHEET 18	OPTIONAL BASE RAIL ON GRADE APPLICATION
SHEET 19	OPTIONAL BASE RAIL ON TIMBER BEAM
SHEET 20	OPTIONAL BASE RAIL ON TIMBER BEAM WITH SOIL NAIL
SHEET 21	OPTIONAL CONCRETE STRIP FOOTING

MOORE AND ASSOCIATES ENGINEERING AND CONSULTING, INC.	DRAWN BY: LT	STEEL BUILDINGS AND STRUCTURES, INC. P.O. BOX 1287, MOUNT AIRY, NC 27030		
	CHECKED BY: PDH	30'-0" x 20'-0" ENCLOSED STRUCTURE		
THIS DOCUMENT IS THE PROPERTY OF MOORE AND ASSOCIATES ENGINEERING AND CONSULTING. THE UNAUTHORIZED REPRODUCTION, COPYING, OR OTHERWISE USE OF THIS DOCUMENT IS STRICTLY PROHIBITED AND ANY INFRINGEMENT THEREUPON MAY BE SUBJECT TO LEGAL ACTION.	PROJECT MGR: WSM	DATE: 12-11-20	SCALE: NTS	JOB NO: 18068S/18156S 18290S/20019S/20324S
	CLIENT: SBSI	SHT. 2	DWG. NO: SK-3	REV. 9

INSTALLATION NOTES AND SPECIFICATIONS

1. DESIGN IS FOR MAXIMUM 30'-0" WIDE x 20'-0" EAVE HEIGHT ENCLOSED STRUCTURES
2. DESIGN WAS DONE IN ACCORDANCE WITH THE 2020 FLORIDA BUILDING CODE (FBC) 7TH EDITION, 2018 NORTH CAROLINA BUILDING CODE, 2006 INTERNATIONAL BUILDING CODE (IBC), 2009 IBC, 2012 IBC, 2015 IBC AND 2018 IBC
3. DESIGN LOADS ARE AS FOLLOWS:
 - A) DEAD LOAD = 1.5 PSF
 - B) LIVE LOAD = 12 PSF
 - C) GROUND SNOW LOAD = 30 PSF ($\leq 26'-0"$), 35 PSF ($26'-0" < W < 30'-0"$)

NOTE: (UNBALANCED SNOW LOADS DUE TO DRIFTING HAVE NOT BEEN EVALUATED)
4. 3-SECOND GUST ULTIMATE WIND SPEED (V_{ULT}) = 105 TO 145 MPH (NOMINAL WIND SPEED = 82 TO 112 MPH)
5. MAXIMUM RAFTER/COLUMN AND END COLUMN SPACING = 5.0 FEET (UNLESS NOTED OTHERWISE)
6. END WALL COLUMNS (POSTS) ARE EQUIVALENT TO SIDE WALL POSTS IN SIZE AND SPACING (UNLESS NOTED OTHERWISE)
7. RISK CATEGORY I
8. WIND EXPOSURE CATEGORY B.
9. SPECIFICATIONS APPLICABLE TO 29 GAUGE METAL PANELS FASTENED DIRECTLY TO 2 1/2" x 2 1/2" - 14 GAUGE TUBE STEEL (TS) FRAMING MEMBERS (UNLESS NOTED OTHERWISE).
10. AVERAGE FASTENER SPACING ON-CENTERS ALONG RAFTERS OR HAT CHANNELS, AND COLUMNS (INTERIOR OR END) = 8 INCHES.
11. FASTENERS CONSIST OF 1/4"x3/4" SELF-DRILLING FASTENER (SDF), USE CONTROL SEAL WASHER WITH EXTERIOR FASTENERS. SPECIFICATIONS APPLICABLE ONLY FOR MEAN ROOF HEIGHT OF 20 FEET OR LESS, AND ROOF SLOPES OF 14" (3:12 PITCH) OR LESS SPACING REQUIREMENTS FOR OTHER ROOF HEIGHTS AND/OR SLOPES MAY VARY. ROOF SLOPES LESS THAN 3:12 REQUIRE USE OF LAP JOINT SEALANT
12. GROUND ANCHORS SHALL BE INSTALLED THROUGH BASE RAIL WITHIN 6" OF EACH COLUMN.
13. STANDARD GROUND ANCHORS (SOIL NAILS) CONSIST OF #4 REBAR W/ WELDED NUT x 36" LONG AND MAY BE USED IN SUITABLE SOILS. OPTIONAL ANCHORAGE MAY BE USED IN SUITABLE SOILS AND MUST BE USED IN UNSUITABLE SOILS AS NOTED.
14. WIND FORCES GOVERN OVER SEISMIC FORCES. SEISMIC PARAMETERS ANALYZED ARE:
 - SOIL SITE CLASS = D
 - RISK CATEGORY I
 - R = 3.25 $I_E = 10$
 - $S_{DS} = 2.039 g$ $V = C_s W$
 - $S_{D1} = 1.258 g$
15. WINDOW AND DOOR DESIGN PRESSURES ARE APPLICABLE TO THE STATE OF FLORIDA ONLY

**MOORE AND ASSOCIATES
ENGINEERING AND CONSULTING, INC.**

DRAWN BY: LT

CHECKED BY: PDH

PROJECT MGR: WSM

CLIENT: SBSI

STEEL BUILDINGS AND STRUCTURES, INC.
P.O. BOX 1287,
MOUNT AIRY, NC 27030
30'-0" x 20'-0" ENCLOSED STRUCTURE

DATE: 12-11-20

SCALE: NTS

SHT. 3

DWG. NO: SK-3

JOB NO: 18068S/18156S
18290S/20019S/20324S

REV: 9

THIS DOCUMENT IS THE PROPERTY OF MOORE AND ASSOCIATES ENGINEERING AND CONSULTING. THE UNAUTHORIZED REPRODUCTION, COPYING, OR OTHERWISE USE OF THIS DOCUMENT IS STRICTLY PROHIBITED AND ANY INFRINGEMENT THEREUPON MAY BE SUBJECT TO LEGAL ACTION.

BOX EAVE FRAME RAFTER STRUCTURE

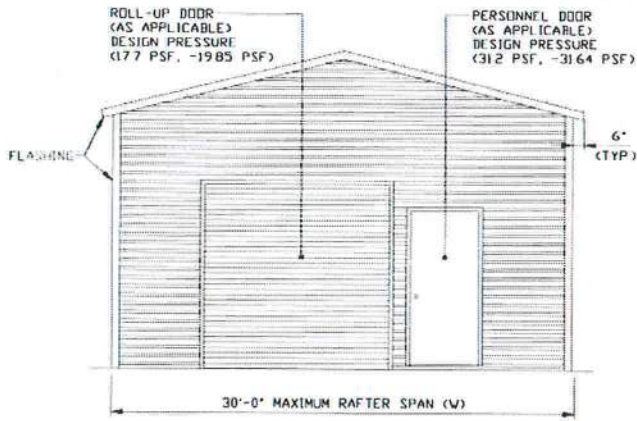

TYPICAL END ELEVATION

SCALE: NTS

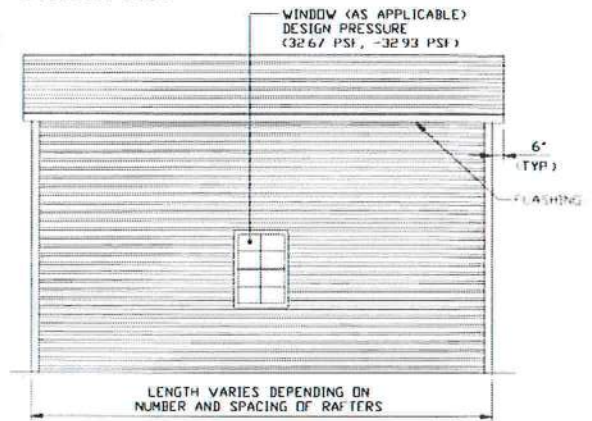

TYPICAL SIDE ELEVATION

SCALE: NTS

BOW EAVE FRAME RAFTER STRUCTURE

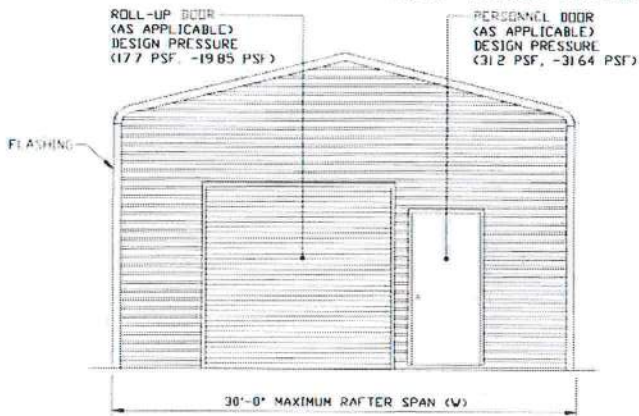

TYPICAL END ELEVATION

SCALE: NTS

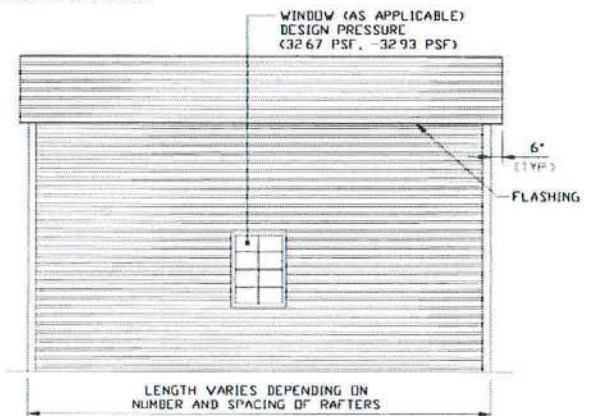

TYPICAL SIDE ELEVATION

SCALE: NTS

**MOORE AND ASSOCIATES
ENGINEERING AND CONSULTING, INC.**

DRAWN BY: LT

CHECKED BY: PDH

PROJECT MGR: WSM

CLIENT: SBSI

STEEL BUILDINGS AND STRUCTURES, INC.
P.O. BOX 1287,
MOUNT AIRY, NC 27030
30'-0" x 20'-0" ENCLOSED STRUCTURE

DATE: 12-11-20

SHT. 4

SCALE: NTS

DWG. NO: SK-3

JOB NO: 18068S/18156S
18290S/20019S/20324S

REV: 9

THIS DOCUMENT IS THE PROPERTY OF MOORE AND ASSOCIATES ENGINEERING AND CONSULTING. THE UNAUTHORIZED REPRODUCTION, COPYING, OR OTHERWISE USE OF THIS DOCUMENT IS STRICTLY PROHIBITED AND ANY INFRINGEMENT THEREUPON MAY BE SUBJECT TO LEGAL ACTION.

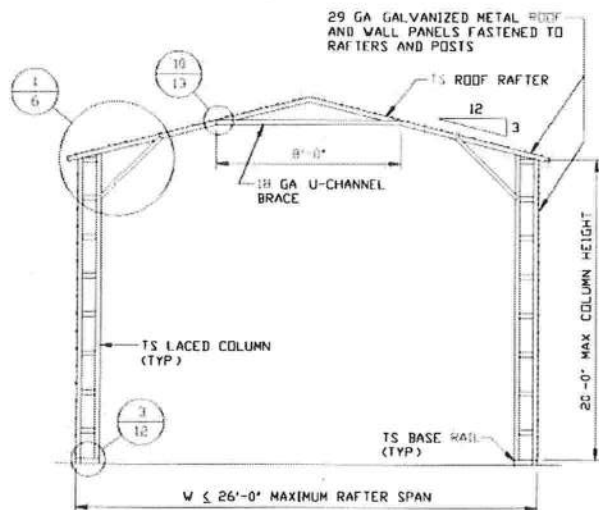

TYPICAL RAFTER/COLUMN FRAME SECTION
SCALE: NTS

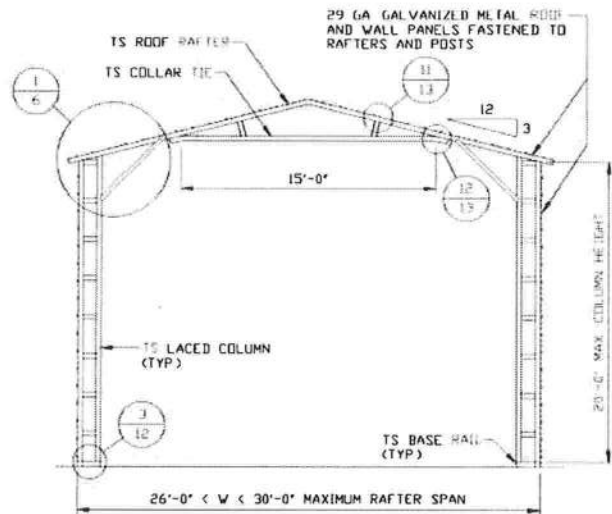

TYPICAL RAFTER/COLUMN FRAME SECTION
SCALE: NTS

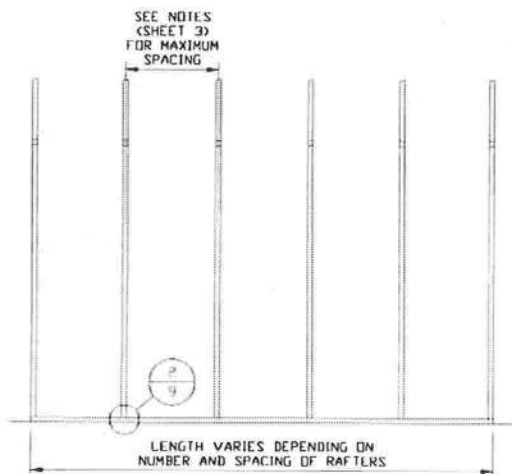

TYPICAL RAFTER/COLUMN SIDE FRAMING SECTION
SCALE: NTS

**MOORE AND ASSOCIATES
ENGINEERING AND CONSULTING, INC.**

DRAWN BY: LT

CHECKED BY: PDH

PROJECT MGR: WSM

CLIENT: SBSI

STEEL BUILDINGS AND STRUCTURES, INC.
P.O. BOX 1287,
MOUNT AIRY, NC 27030
30'-0" x 20'-0" ENCLOSED STRUCTURE

DATE: 12-11-20

SCALE: NTS

SHT. 5

DWG. NO: SK-3

JOB NO: 18068S/18156S
18290S/20019S/20324S

REV: 9

THIS DOCUMENT IS THE PROPERTY OF MOORE AND ASSOCIATES ENGINEERING AND CONSULTING. THE UNAUTHORIZED REPRODUCTION, COPYING, OR OTHERWISE USE OF THIS DOCUMENT IS STRICTLY PROHIBITED AND ANY INFRINGEMENT THEREUPON MAY BE SUBJECT TO LEGAL ACTION.

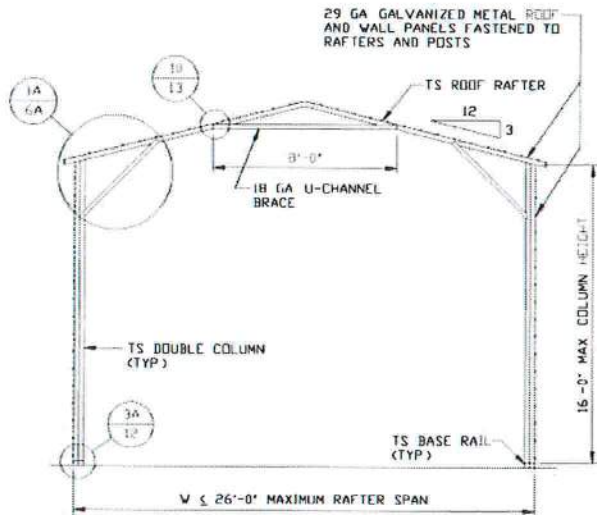

TYPICAL RAFTER/COLUMN FRAME SECTION
SCALE: NTS

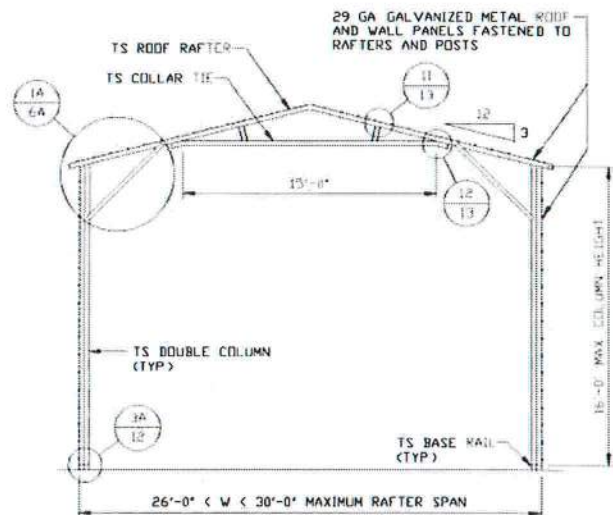

TYPICAL RAFTER/COLUMN FRAME SECTION
SCALE: NTS

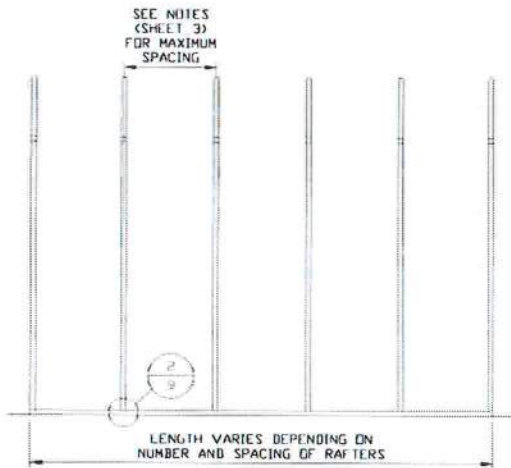

TYPICAL RAFTER/COLUMN SIDE FRAMING SECTION
SCALE: NTS

**MOORE AND ASSOCIATES
ENGINEERING AND CONSULTING, INC.**

DRAWN BY: LT
CHECKED BY: PDH

STEEL BUILDINGS AND STRUCTURES, INC.
P.O. BOX 1287,
MOUNT AIRY, NC 27030
30'-0"x20'-0" ENCLOSED STRUCTURE

THIS DOCUMENT IS THE PROPERTY OF MOORE AND ASSOCIATES ENGINEERING AND CONSULTING. THE UNAUTHORIZED REPRODUCTION, COPYING, OR OTHERWISE USE OF THIS DOCUMENT IS STRICTLY PROHIBITED AND ANY INFRINGEMENT THEREUPON MAY BE SUBJECT TO LEGAL ACTION.

PROJECT MGR: VSM
CLIENT: SBSI

DATE: 12-11-20
SHT. 5A

SCALE: NTS
DWG. NO: SK-3

JOB NO: 18068S/18156S
18290S/20019S/20324S
REV: 9

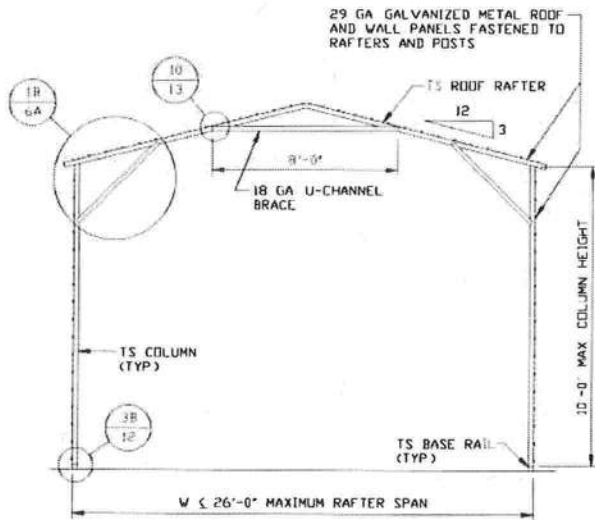

TYPICAL RAFTER/COLUMN FRAME SECTION
SCALE: NTS

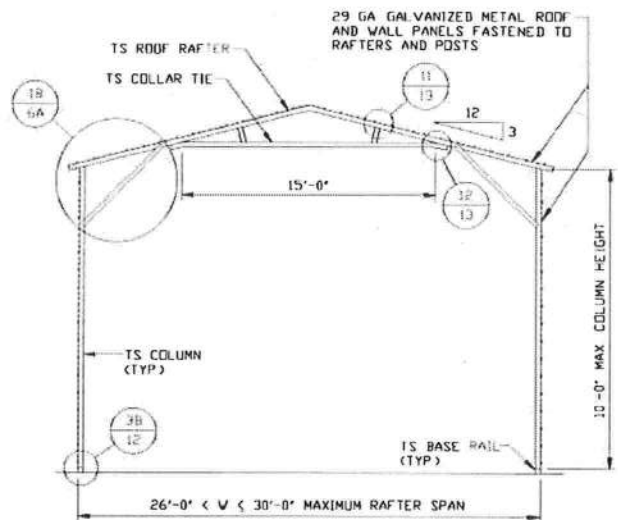

TYPICAL RAFTER/COLUMN FRAME SECTION
SCALE: NTS

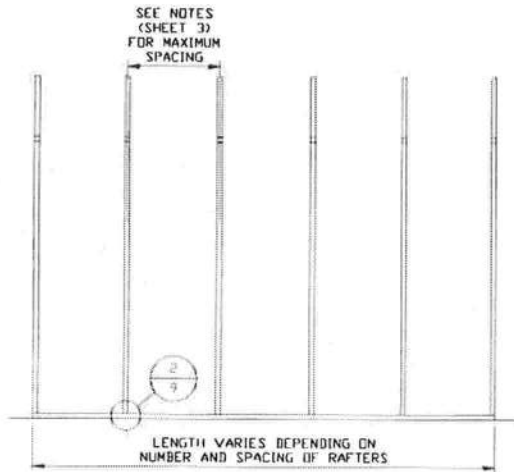

TYPICAL RAFTER/COLUMN SIDE FRAMING SECTION
SCALE: NTS

**MOORE AND ASSOCIATES
ENGINEERING AND CONSULTING, INC.**

DRAWN BY: LT

CHECKED BY: PDH

PROJECT MGR: WSM

CLIENT: SBSI

STEEL BUILDINGS AND STRUCTURES, INC.
P.O. BOX 1287,
MOUNT AIRY, NC 27030
30'-0" x 20'-0" ENCLOSED STRUCTURE

DATE: 12-11-20

SHT. 5B

SCALE: NTS

DWG. NO: SK-3

JOB NO: 18068S/18156S
18290S/20019S/20324S

REV: 9

THIS DOCUMENT IS THE PROPERTY OF MOORE AND ASSOCIATES ENGINEERING AND CONSULTING. THE UNAUTHORIZED REPRODUCTION, COPYING, OR OTHERWISE USE OF THIS DOCUMENT IS STRICTLY PROHIBITED AND ANY INFRINGEMENT THEREUPON MAY BE SUBJECT TO LEGAL ACTION.

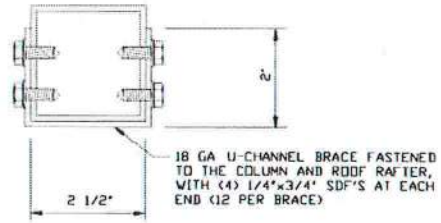
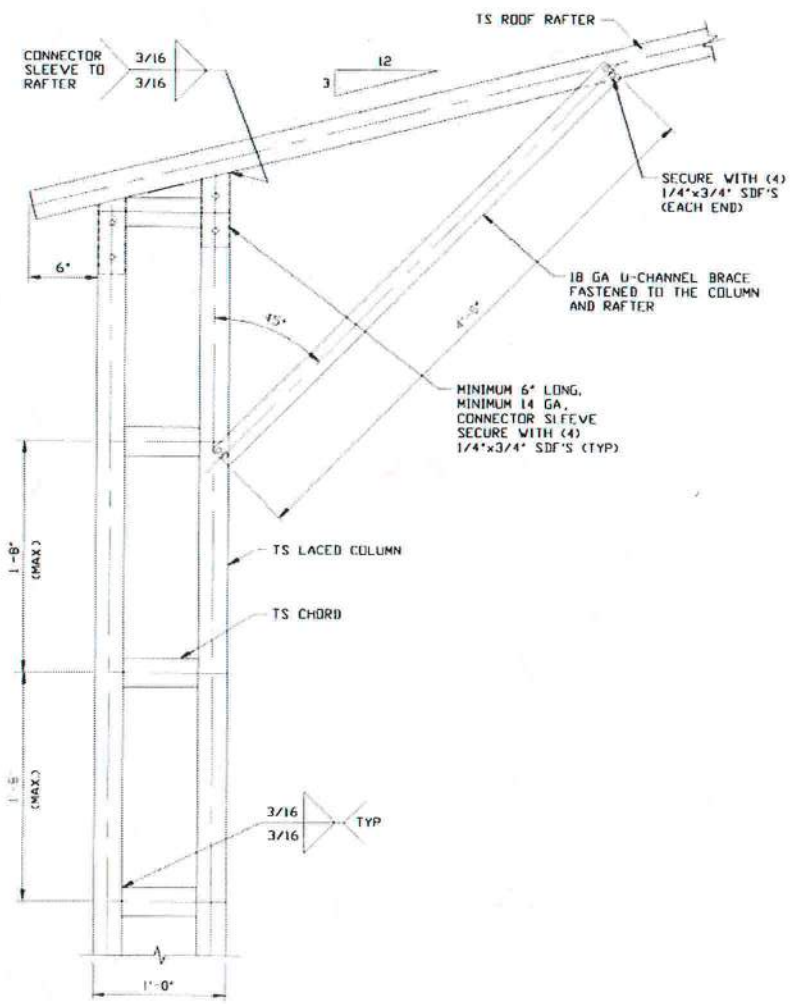

BRACE SECTION
SCALE: NTS

1
BOX EAVE RAFTER/CORNER POST CONNECTION DETAIL
FOR HEIGHTS 16'-0" < TO ≤ 20'-0"
SCALE: NTS

MOORE AND ASSOCIATES
ENGINEERING AND CONSULTING, INC.

DRAWN BY: LT
CHECKED BY: PDH
PROJECT MGR: VSM
CLIENT: SBSI

STEEL BUILDINGS AND STRUCTURES, INC.
P.O. BOX 1287,
MOUNT AIRY, NC 27030
30'-0" x 20'-0" ENCLOSED STRUCTURE

THIS DOCUMENT IS THE PROPERTY OF MOORE AND ASSOCIATES ENGINEERING AND CONSULTING. THE UNAUTHORIZED REPRODUCTION, COPYING, OR OTHERWISE USE OF THIS DOCUMENT IS STRICTLY PROHIBITED AND ANY INFRINGEMENT THEREUPON MAY BE SUBJECT TO LEGAL ACTION.

DATE: 12-11-20 **SCALE: NTS** **JOB NO: 18068S/18156S**
SHT. 6 **DWG. NO: SK-3** **REV: 9**
18290S/20019S/20324S

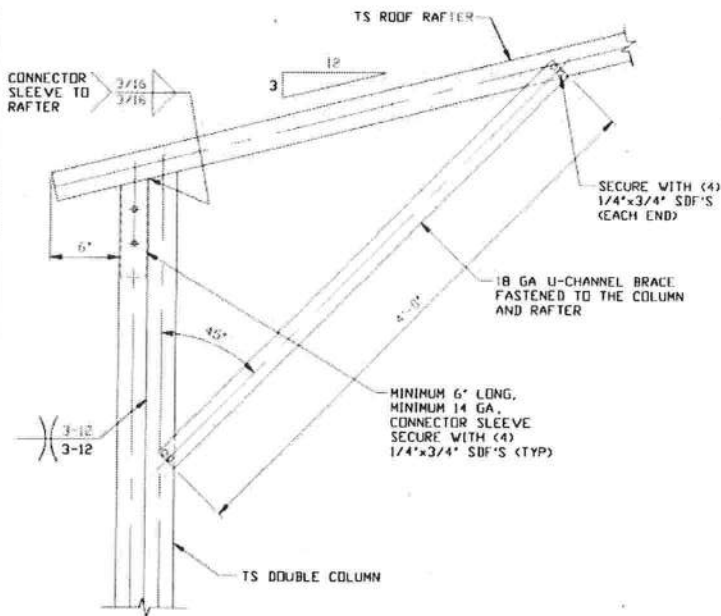

BOX EAVE RAFTER/CORNER POST CONNECTION DETAIL FOR HEIGHTS 10'-0" < TO ≤ 16'-0"

1A

SCALE: NTS

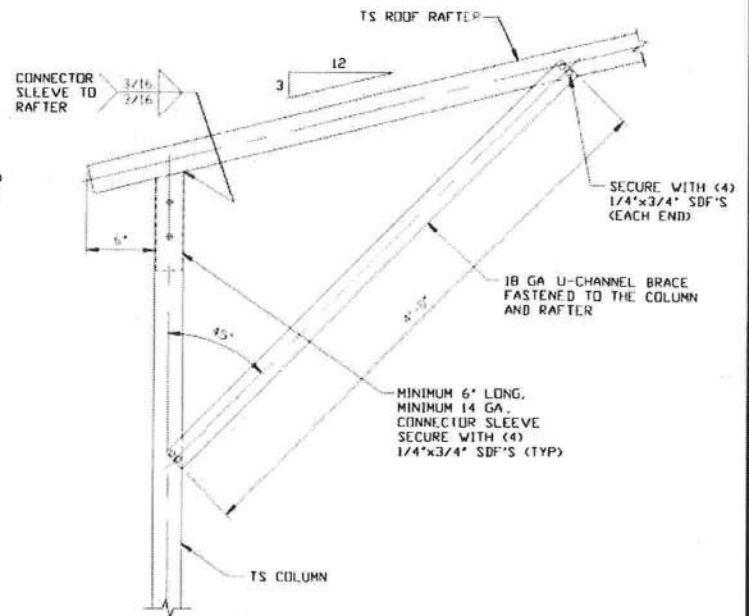

BOX EAVE RAFTER/CORNER POST CONNECTION DETAIL FOR HEIGHTS ≤ 10'-0"

1B

SCALE: NTS

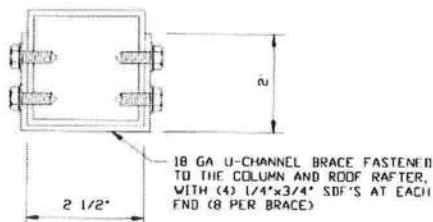

BRACE SECTION

SCALE: NTS

**MOORE AND ASSOCIATES
ENGINEERING AND CONSULTING, INC.**

DRAWN BY: LT

CHECKED BY: PDH

PROJECT MGR: WSM

CLIENT: SBSI

STEEL BUILDINGS AND STRUCTURES, INC.
P.O. BOX 1287,
MOUNT AIRY, NC 27030
30'-0" x 20'-0" ENCLOSED STRUCTURE

DATE: 12-11-20

SCALE: NTS

SHT. 6A

DWG. NO: SK-3

JOB NO: 18068S/18156S
18290S/20019S/20324S

REV: 9

THIS DOCUMENT IS THE PROPERTY OF MOORE AND ASSOCIATES ENGINEERING AND CONSULTING. THE UNAUTHORIZED REPRODUCTION, COPYING, OR OTHERWISE USE OF THIS DOCUMENT IS STRICTLY PROHIBITED AND ANY INFRINGEMENT THEREUPON MAY BE SUBJECT TO LEGAL ACTION.

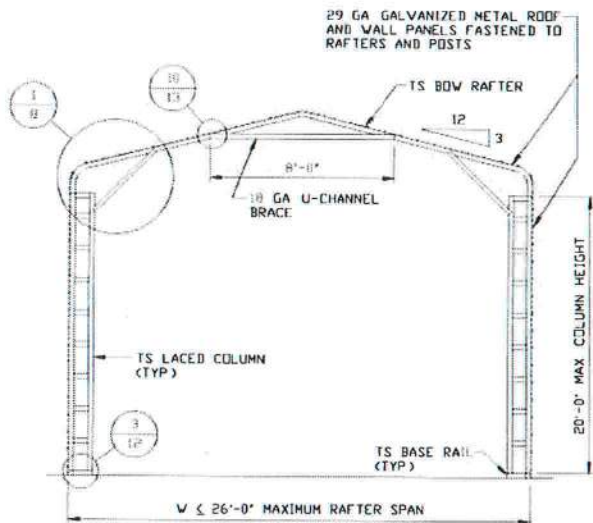

TYPICAL RAFTER/COLUMN FRAME SECTION
SCALE: NTS

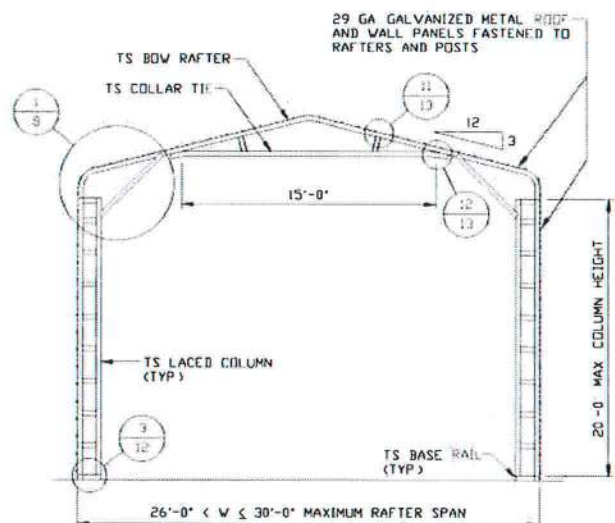

TYPICAL RAFTER/COLUMN FRAME SECTION
SCALE: NTS

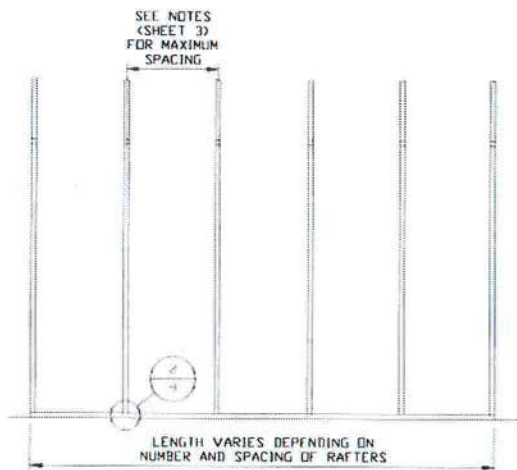

TYPICAL RAFTER/COLUMN SIDE FRAMING SECTION
SCALE: NTS

**MOORE AND ASSOCIATES
ENGINEERING AND CONSULTING, INC.**

DRAWN BY: LT

CHECKED BY: PDH

PROJECT MGR: WSM

CLIENT: SBSI

STEEL BUILDINGS AND STRUCTURES, INC.
P.O. BOX 1287,
MOUNT AIRY, NC 27030
30'-0" x 20'-0" ENCLOSED STRUCTURE

DATE: 12-11-20

SHT. 7

SCALE: NTS

DWG. NO: SK-3

JOB NO: 18068S/18156S
18290S/20019S/20324S

REV: 9

THIS DOCUMENT IS THE PROPERTY OF MOORE AND ASSOCIATES ENGINEERING AND CONSULTING. THE UNAUTHORIZED REPRODUCTION, COPYING, OR OTHERWISE USE OF THIS DOCUMENT IS STRICTLY PROHIBITED AND ANY INFRINGEMENT THEREUPON MAY BE SUBJECT TO LEGAL ACTION.

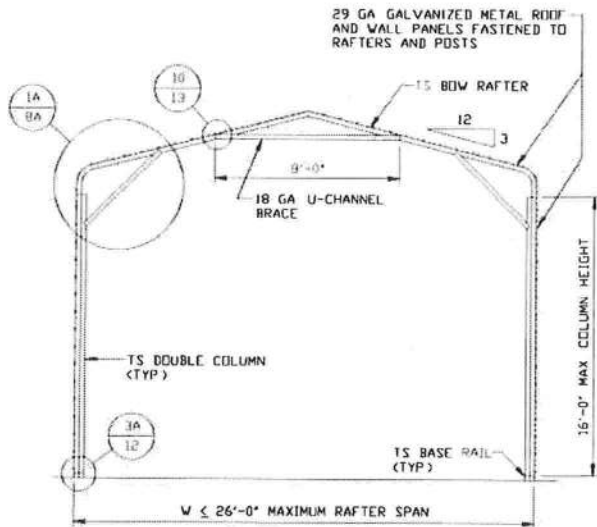

TYPICAL RAFTER/COLUMN FRAME SECTION
SCALE: NTS

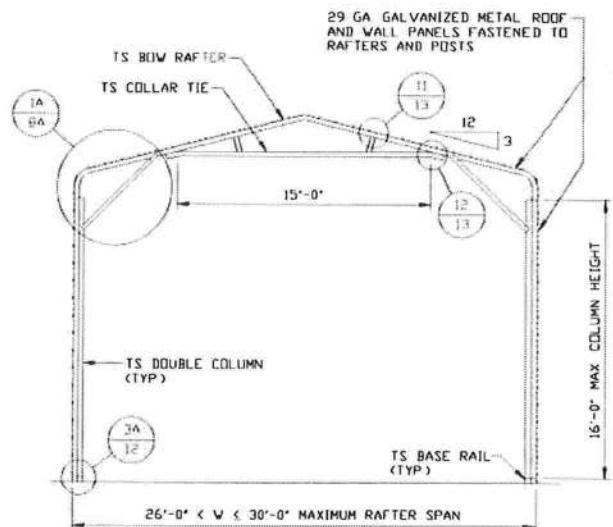

TYPICAL RAFTER/COLUMN FRAME SECTION
SCALE: NTS

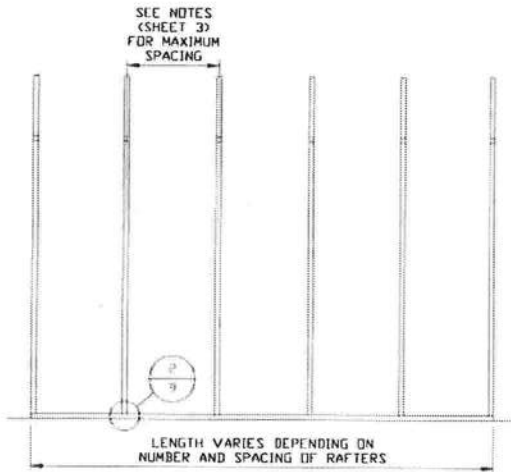

TYPICAL RAFTER/COLUMN SIDE FRAMING SECTION
SCALE: NTS

**MOORE AND ASSOCIATES
ENGINEERING AND CONSULTING, INC.**

DRAWN BY: LT

CHECKED BY: PDH

PROJECT MGR: WSM

CLIENT: SBSI

STEEL BUILDINGS AND STRUCTURES, INC.
P.O. BOX 1287,
MOUNT AIRY, NC 27030
30'-0" x 20'-0" ENCLOSED STRUCTURE

DATE: 12-11-20

SHT. 7A

SCALE: NTS

DWG. NO: SK-3

JOB NO: 18068S/18156S
18290S/20019S/20324S

REV: 9

THIS DOCUMENT IS THE PROPERTY OF MOORE AND ASSOCIATES ENGINEERING AND CONSULTING. THE UNAUTHORIZED REPRODUCTION, COPYING, OR OTHERWISE USE OF THIS DOCUMENT IS STRICTLY PROHIBITED AND ANY INFRINGEMENT THEREUPON MAY BE SUBJECT TO LEGAL ACTION.

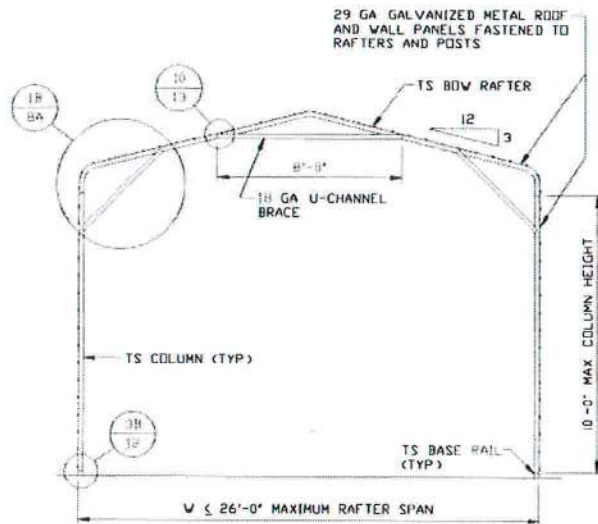

TYPICAL RAFTER/COLUMN FRAME SECTION
SCALE: NTS

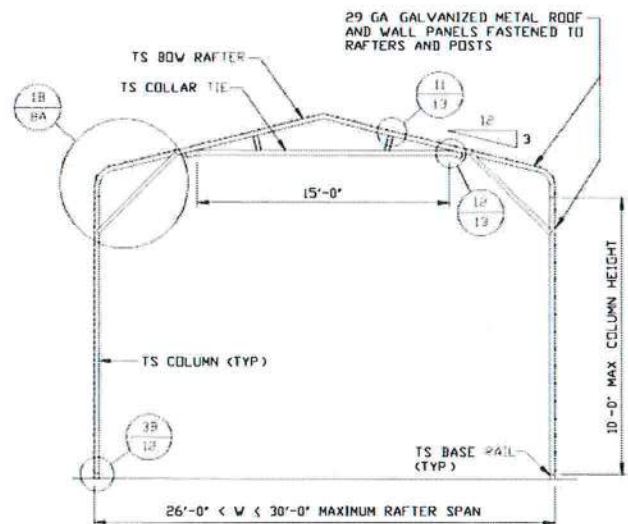

TYPICAL RAFTER/COLUMN FRAME SECTION
SCALE: NTS

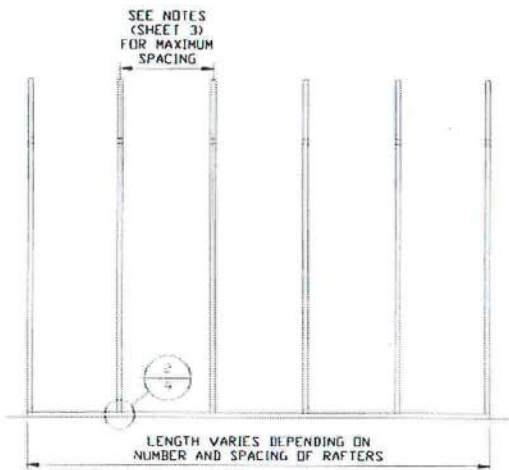

TYPICAL RAFTER/COLUMN SIDE FRAMING SECTION
SCALE: NTS

**MOORE AND ASSOCIATES
ENGINEERING AND CONSULTING, INC.**

DRAWN BY: LT
CHECKED BY: PDH
PROJECT MGR: WSM
CLIENT: SBSI

STEEL BUILDINGS AND STRUCTURES, INC.
P.O. BOX 1287,
MOUNT AIRY, NC 27030
30'-0" x 20'-0" ENCLOSED STRUCTURE

THIS DOCUMENT IS THE PROPERTY OF MOORE AND ASSOCIATES ENGINEERING AND CONSULTING. THE UNAUTHORIZED REPRODUCTION, COPYING, OR OTHERWISE USE OF THIS DOCUMENT IS STRICTLY PROHIBITED AND ANY INFRINGEMENT THEREUPON MAY BE SUBJECT TO LEGAL ACTION.

DATE: 12-11-20
SHT. 7B

SCALE: NTS
DWG. NO: SK-3

JOB NO: 18068S/18156S
18290S/20019S/20324S
REV: 9

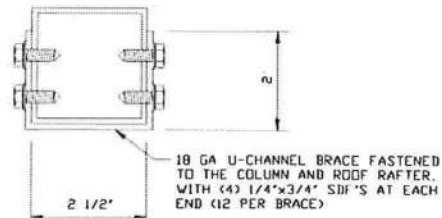
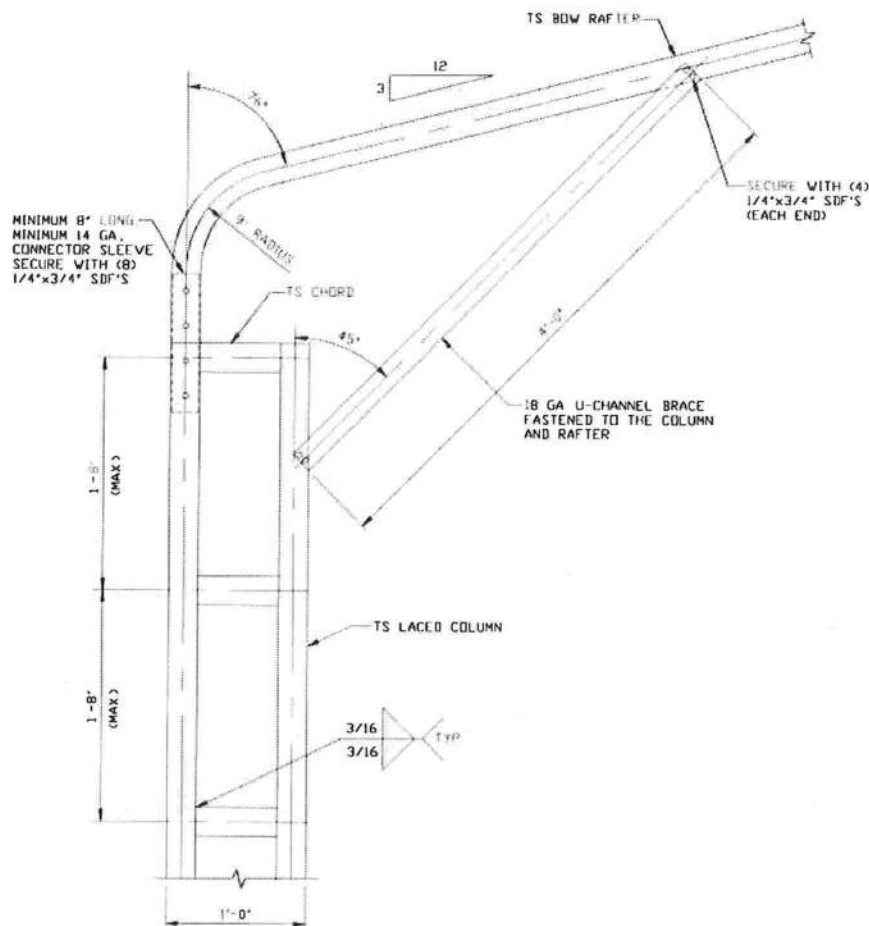

BRACE SECTION
SCALE: NTS

1 BOX EAVE RAFTER/CORNER POST CONNECTION DETAIL FOR HEIGHTS 16'-0" < TO ≤ 20'-0" SCALE: NTS

**MOORE AND ASSOCIATES
ENGINEERING AND CONSULTING, INC.**

DRAWN BY: LT

CHECKED BY: PDH

PROJECT MGR: WSM

CLIENT: SBSI

STEEL BUILDINGS AND STRUCTURES, INC.
P.O. BOX 1287,
MOUNT AIRY, NC 27030
30'-0" x 20'-0" ENCLOSED STRUCTURE

DATE: 12-11-20

SHT. 8

SCALE: NTS

DWG. NO: SK-3

JOB NO: 18068S/18156S
18290S/20019S/20324S

REV. 9

THIS DOCUMENT IS THE PROPERTY OF MOORE AND ASSOCIATES ENGINEERING AND CONSULTING. THE UNAUTHORIZED REPRODUCTION, COPYING, OR OTHERWISE USE OF THIS DOCUMENT IS STRICTLY PROHIBITED AND ANY INFRINGEMENT THEREUPON MAY BE SUBJECT TO LEGAL ACTION.

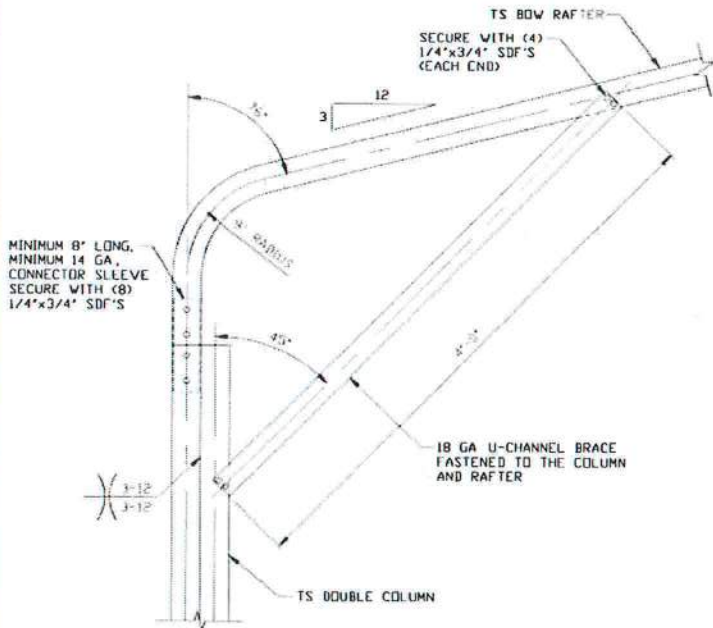

1A

BOX EAVE RAFTER/CORNER POST CONNECTION DETAIL FOR HEIGHTS 10'-0" < TO ≤ 16'-0"
SCALE: NTS

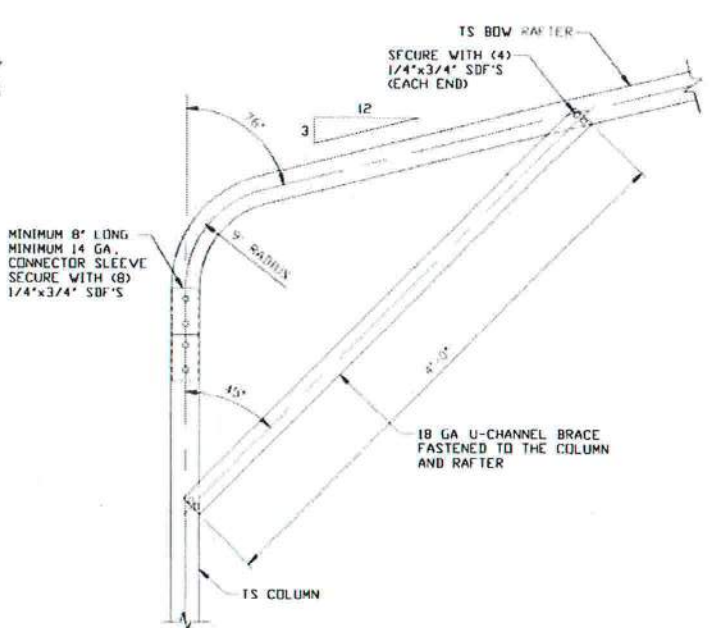

1B

BOX EAVE RAFTER/CORNER POST CONNECTION DETAIL FOR HEIGHTS ≤ 10'-0"
SCALE: NTS

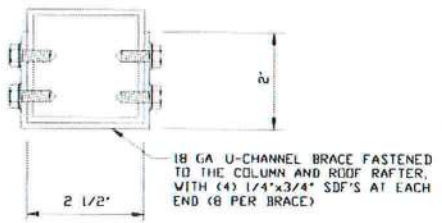

BRACE SECTION
SCALE: NTS

MOORE AND ASSOCIATES ENGINEERING AND CONSULTING, INC.	DRAWN BY: LT	STEEL BUILDINGS AND STRUCTURES, INC. P.O. BOX 1287, MOUNT AIRY, NC 27030 30'-0" x 20'-0" ENCLOSED STRUCTURE		
	CHECKED BY: PDH			
THIS DOCUMENT IS THE PROPERTY OF MOORE AND ASSOCIATES ENGINEERING AND CONSULTING. THE UNAUTHORIZED REPRODUCTION, COPYING, OR OTHERWISE USE OF THIS DOCUMENT IS STRICTLY PROHIBITED AND ANY INFRINGEMENT THEREUPON MAY BE SUBJECT TO LEGAL ACTION.	PROJECT MGR: WSM	DATE: 12-11-20	SCALE: NTS	JOB NO: 18068S/18156S 18290S/20019S/20324S
	CLIENT: SBSI	SHT. 0A	DWG. NO: SK-3	REV: 9

BASE RAIL ANCHORAGE OPTIONS

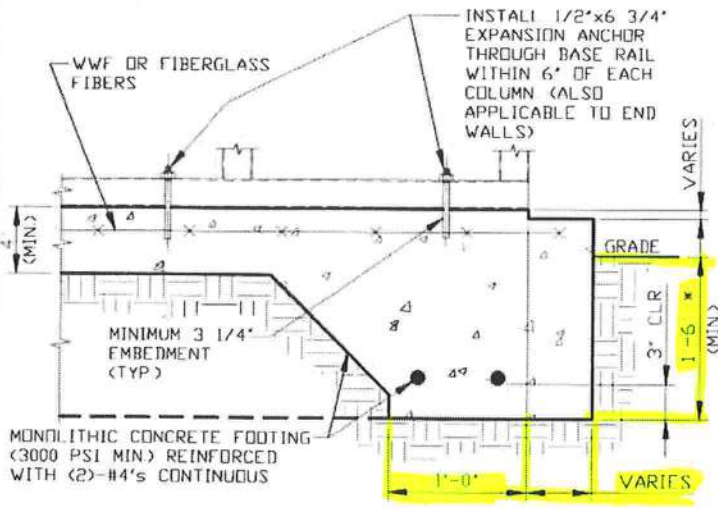

2 CONCRETE MONOLITHIC SLAB BASE RAIL ANCHORAGE
 SCALE: NTS
 MINIMUM ANCHOR EDGE DISTANCE IS 4"
 * COORDINATE WITH LOCAL CODES/ORD.

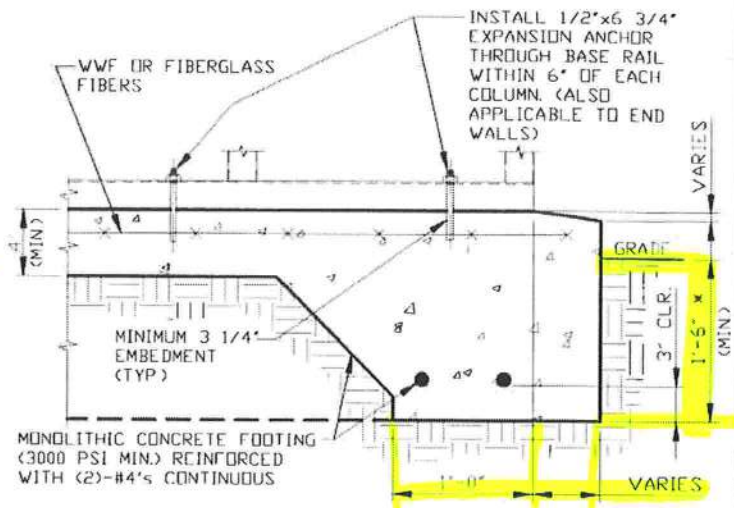

2A CONCRETE SLAB BASE RAIL ANCHORAGE
 SCALE: NTS
 MINIMUM ANCHOR EDGE DISTANCE IS 4"
 * COORDINATE WITH LOCAL CODES/ORD.

GENERAL NOTES

NOTE: CONCRETE MONOLITHIC SLAB DESIGN BASED ON MINIMUM SOIL BEARING CAPACITY OF 1,500 PSF

CONCRETE:

CONCRETE SHALL HAVE A MINIMUM SPECIFIED COMPRESSIVE STRENGTH OF 3,000 PSI AT 28 DAYS

COVER OVER REINFORCING STEEL:

FOR FOUNDATIONS, MINIMUM CONCRETE COVER OVER REINFORCING BARS SHALL BE PER ACI-318:
 3" IN FOUNDATIONS WHERE THE CONCRETE IS CAST AGAINST AND PERMANENTLY IN CONTACT WITH THE EARTH OR EXPOSED TO THE EARTH OR WEATHER, AND 1 1/2" ELSEWHERE

REINFORCING STEEL:

THE TURNDOWN REINFORCING STEEL SHALL BE ASTM A615 GRADE 60 THE SLAB REINFORCEMENT SHALL BE WELDED WIRE FABRIC MEETING ASTM A185 OR FIBERGLASS FIBER REINFORCEMENT

REINFORCEMENT MAY BE BENT IN THE SHOP OR THE FIELD PROVIDED:

- 1 REINFORCEMENT IS BENT COLD
- 2 THE DIAMETER OF THE BEND, MEASURED ON THE INSIDE OF THE BAR, IS NOT LESS THAN SIX-BAR DIAMETERS
- 3 REINFORCEMENT PARTIALLY EMBEDDED IN CONCRETE SHALL NOT BE FIELD BENT

HELIX ANCHOR NOTES:

- 1 FOR VERY DENSE AND/OR CEMENTED SANDS, COARSE GRAVEL AND COBBLES, CALICHE, PRELOADED SILTS AND CLAYS, USE MINIMUM (2) 4" HELICES WITH MINIMUM 30" EMBEDMENT OR SINGLE 6" HELIX WITH MINIMUM 50" EMBEDMENT
- 2 FOR CORAL USE MINIMUM (2) 4" HELICES WITH MINIMUM 30" EMBEDMENT OR SINGLE 6" HELIX WITH MINIMUM 50" EMBEDMENT
- 3 FOR MEDIUM DENSE COARSE SANDS, SANDY GRAVELS, VERY STIFF SILTS, AND CLAYS USE MINIMUM (2) 4" HELICES WITH MINIMUM 30 INCH EMBEDMENT OR SINGLE 6" HELIX WITH MINIMUM 50" EMBEDMENT
- 4 FOR LOOSE TO MEDIUM DENSE SANDS, FIRM TO STIFF CLAYS AND SILTS ALLUVIAL FILL, USE MINIMUM (2) 6" HELICES WITH MINIMUM 50" EMBEDMENT
- 5 FOR VERY LOOSE TO MEDIUM DENSE SANDS, FIRM TO STIFFER CLAYS AND SILTS, ALLUVIAL FILL, USE MINIMUM (2) 8" HELICES WITH MINIMUM 60" EMBEDMENT

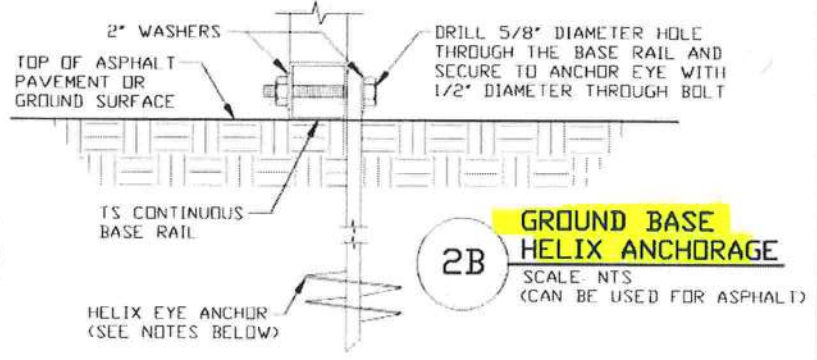

2B GROUND BASE HELIX ANCHORAGE
 SCALE: NTS
 (CAN BE USED FOR ASPHALT)

**MOORE AND ASSOCIATES
 ENGINEERING AND CONSULTING, INC.**

DRAWN BY: LT
CHECKED BY: PDH
PROJECT MGR: WSM
CLIENT: SBSI

STEEL BUILDINGS AND STRUCTURES, INC. P.O. BOX 1287, MOUNT AIRY, NC 27030 30'-0" x 20'-0" ENCLOSED STRUCTURE			
DATE: 12-11-20	SCALE: NTS	JOB NO: 18068S/18156S	
SHT. 9	DWG. NO.: SK-3	18290S/20019S/20324S	
			REV: 9

THIS DOCUMENT IS THE PROPERTY OF MOORE AND ASSOCIATES ENGINEERING AND CONSULTING. THE UNAUTHORIZED REPRODUCTION, COPYING, OR OTHERWISE USE OF THIS DOCUMENT IS STRICTLY PROHIBITED AND ANY INFRINGEMENT THEREUPON MAY BE SUBJECT TO LEGAL ACTION.

ADDITIONAL BASE RAIL ANCHORAGE OPTION

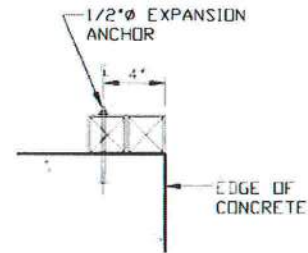
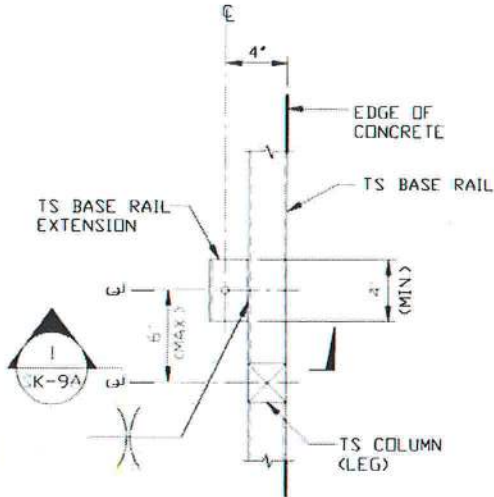

SECTION I
SCALE: NTS

TYPICAL ANCHOR DETAIL WHEN BASE RAIL IS NEAR EDGE OF CONCRETE

SCALE: NTS

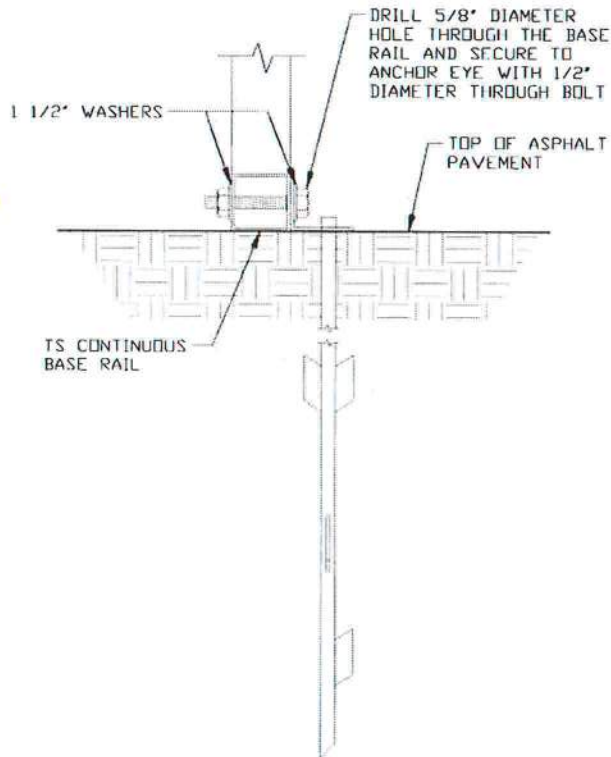

2C

ASPHALT BASE ANCHORAGE

SCALE: NTS

**MOORE AND ASSOCIATES
ENGINEERING AND CONSULTING, INC.**

DRAWN BY: LT

CHECKED BY: PDH

PROJECT MGR: WSM

CLIENT: SBSI

STEEL BUILDINGS AND STRUCTURES, INC.
P.O. BOX 1287,
MOUNT AIRY, NC 27030
30'-0" x 20'-0" ENCLOSED STRUCTURE

DATE: 12-11-20

SHT. 9A

SCALE: NTS

DWG. NO: SK-3

JOB NO: 18068S/18156S

18290S/20019S/20324S

REV: 9

THIS DOCUMENT IS THE PROPERTY OF MOORE AND ASSOCIATES ENGINEERING AND CONSULTING. THE UNAUTHORIZED REPRODUCTION, COPYING, OR OTHERWISE USE OF THIS DOCUMENT IS STRICTLY PROHIBITED AND ANY INFRINGEMENT THEREUPON MAY BE SUBJECT TO LEGAL ACTION.

BOX EAVE RAFTER END WALL AND SIDE WALL OPENINGS

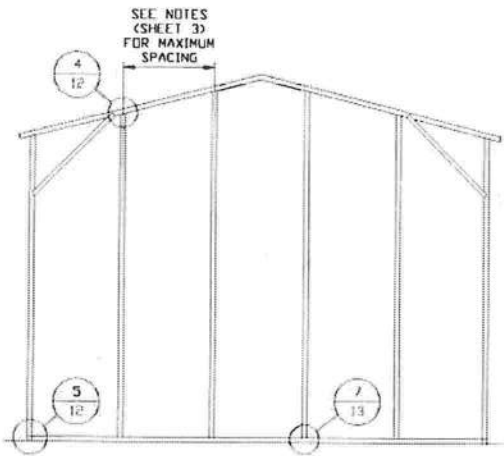

**TYPICAL BOX EAVE RAFTER
END WALL FRAMING SECTION**

SCALE: NTS

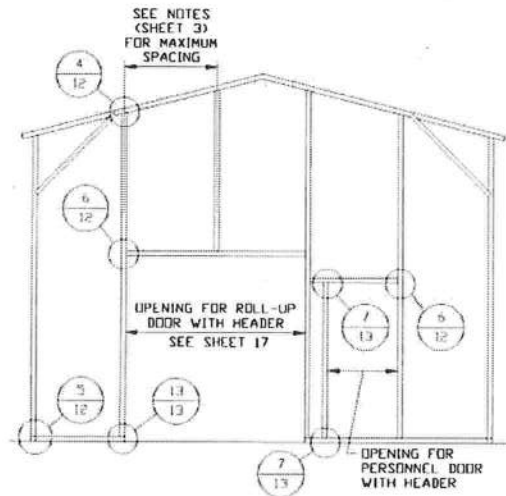

**TYPICAL BOX EAVE RAFTER END
WALL OPENINGS FRAMING SECTION**

SCALE: NTS

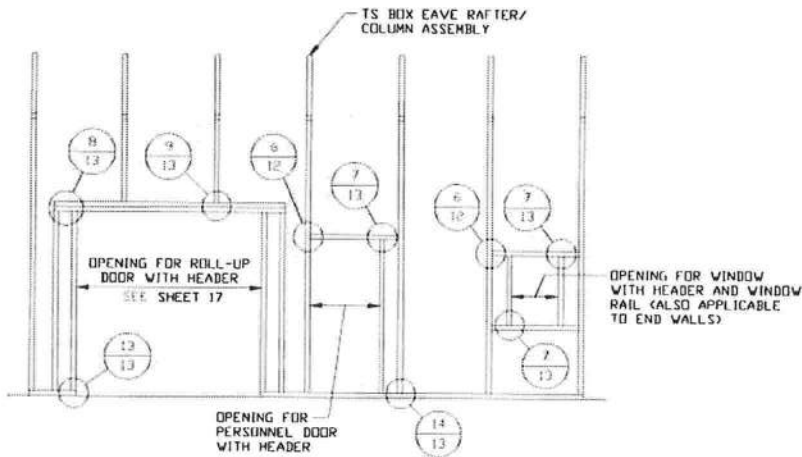

**TYPICAL BOX EAVE RAFTER
SIDE WALL OPENINGS FRAMING SECTION**

SCALE: NTS

**MOORE AND ASSOCIATES
ENGINEERING AND CONSULTING, INC.**

DRAWN BY: LT

CHECKED BY: PDH

PROJECT MGR: WSM

CLIENT: SBSI

STEEL BUILDINGS AND STRUCTURES, INC.
P.O. BOX 1287,
MOUNT AIRY, NC 27030
30'-0" x 20'-0" ENCLOSED STRUCTURE

DATE: 12-11-20

SCALE: NTS

SHT. 10

DWG. NO: SK-3

JOB NO: 18068S/18156S
18290S/20019S/20324S

REV: 9

THIS DOCUMENT IS THE PROPERTY OF MOORE AND ASSOCIATES ENGINEERING AND CONSULTING. THE UNAUTHORIZED REPRODUCTION, COPYING, OR OTHERWISE USE OF THIS DOCUMENT IS STRICTLY PROHIBITED AND ANY INFRINGEMENT THEREUPON MAY BE SUBJECT TO LEGAL ACTION.

BOW EAVE RAFTER END WALL AND SIDE WALL OPENINGS

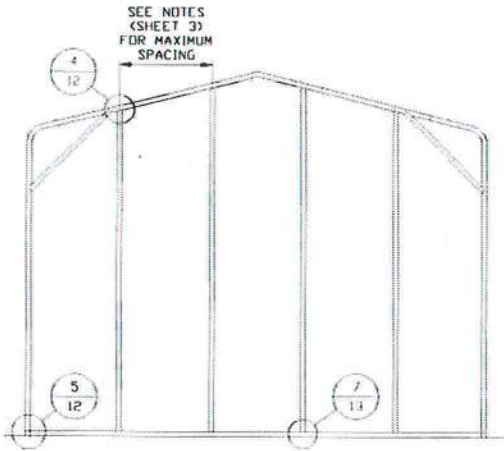

**TYPICAL BOX EAVE RAFTER
END WALL FRAMING SECTION**

SCALE: NTS

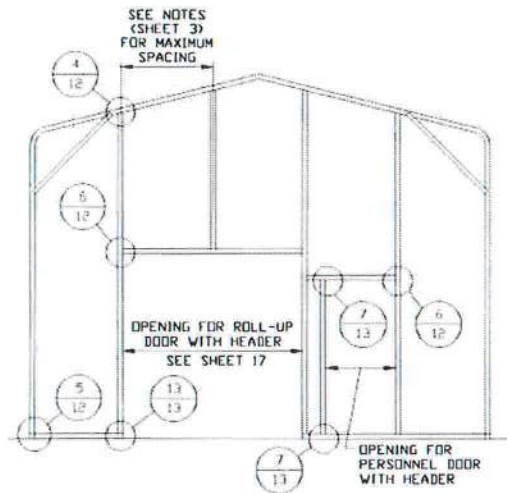

**TYPICAL BOX EAVE RAFTER END
WALL OPENINGS FRAMING SECTION**

SCALE: NTS

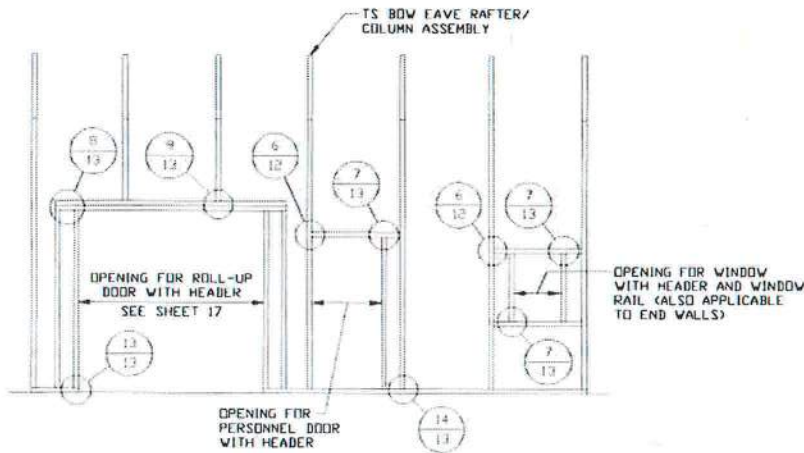

**TYPICAL BOX EAVE RAFTER
SIDE WALL OPENINGS FRAMING SECTION**

SCALE: NTS

**MOORE AND ASSOCIATES
ENGINEERING AND CONSULTING, INC.**

DRAWN BY: LT

CHECKED BY: PDH

PROJECT MGR: WSM

CLIENT: SBSI

STEEL BUILDINGS AND STRUCTURES, INC.
P.O. BOX 1287,
MOUNT AIRY, NC 27030
30'-0" x 20'-0" ENCLOSED STRUCTURE

DATE: 12-11-20

SHT. 11

SCALE: NTS

DWG. NO: SK-3

JOB NO: 18068S/18156S
18290S/P0019S/P0324S

REV: 9

THIS DOCUMENT IS THE PROPERTY OF MOORE AND ASSOCIATES ENGINEERING AND CONSULTING. THE UNAUTHORIZED REPRODUCTION, COPYING, OR OTHERWISE USE OF THIS DOCUMENT IS STRICTLY PROHIBITED AND ANY INFRINGEMENT THEREUPON MAY BE SUBJECT TO LEGAL ACTION.

CONNECTION DETAILS

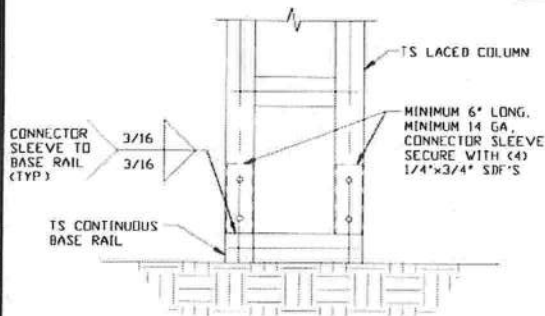

3 POST/BASE RAIL CONNECTION DETAIL
SCALE: NTS

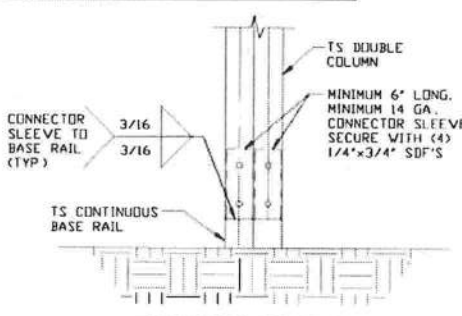

3A POST/BASE RAIL CONNECTION DETAIL
SCALE: NTS

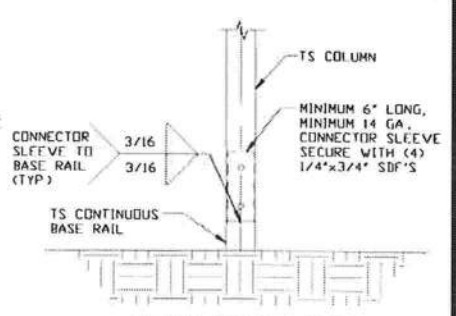

3B POST/BASE RAIL CONNECTION DETAIL
SCALE: NTS

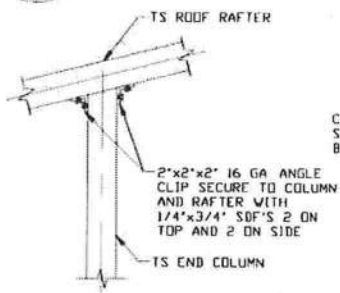

4 END COLUMN/RAFTER CONNECTION DETAIL
SCALE: NTS

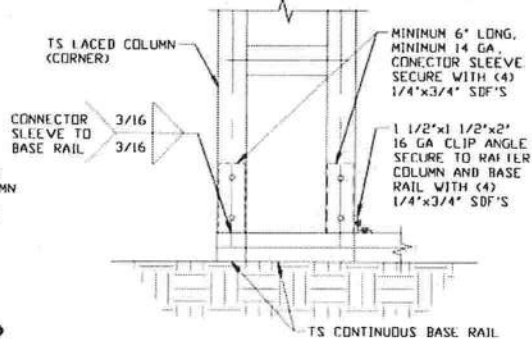

5 END COLUMN/BASE RAIL CONNECTION DETAIL
SCALE: NTS

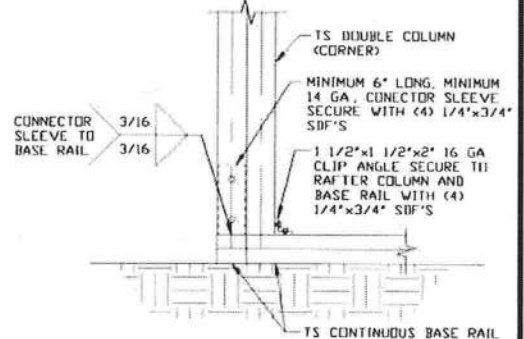

5A END COLUMN/BASE RAIL CONNECTION DETAIL
SCALE: NTS

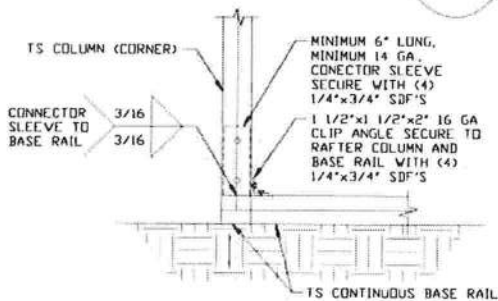

5B END COLUMN/BASE RAIL CONNECTION DETAIL
SCALE: NTS

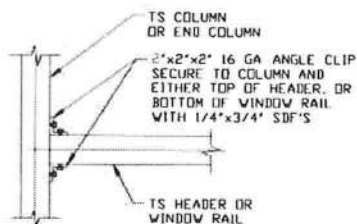

6 COLUMN OR WINDOW RAIL/WALL GIRT TO POST CONNECTION DETAIL
SCALE: NTS

MOORE AND ASSOCIATES ENGINEERING AND CONSULTING, INC.		DRAWN BY: LT CHECKED BY: PDH		STEEL BUILDINGS AND STRUCTURES, INC. P.O. BOX 1287, MOUNT AIRY, NC 27030 30'-0" x 20'-0" ENCLOSED STRUCTURE			
PROJECT MGR: VSM		DATE: 12-11-20		SCALE: NTS		JOB NO: 18068S/18156S 18290S/20019S/20324S	
CLIENT: SBSI		SHT. 12		DWG. NO: SK-3		REV.: 9	

THIS DOCUMENT IS THE PROPERTY OF MOORE AND ASSOCIATES ENGINEERING AND CONSULTING. THE UNAUTHORIZED REPRODUCTION, COPYING, OR OTHERWISE USE OF THIS DOCUMENT IS STRICTLY PROHIBITED AND ANY INFRINGEMENT THEREUPON MAY BE SUBJECT TO LEGAL ACTION.

CONNECTION DETAILS

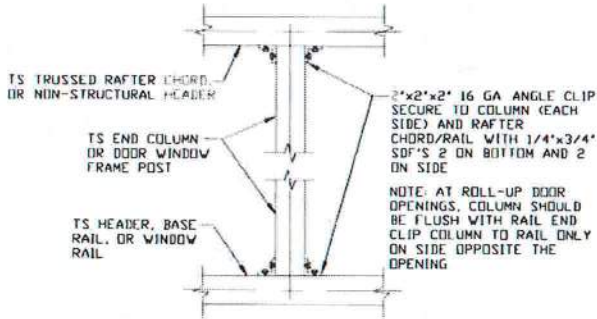

7

COLUMN TO HEADER, BASE RAIL, OR WINDOW RAIL CONNECTION DETAIL

SCALE: NTS

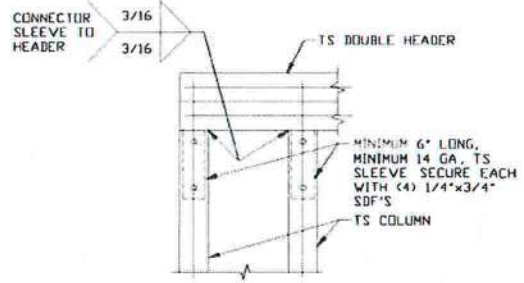

8

DOUBLE HEADER/COLUMN CONNECTION DETAIL

SCALE: NTS

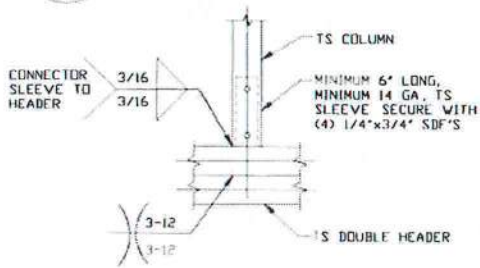

9

COLUMN/DOUBLE HEADER CONNECTION DETAIL

SCALE: NTS

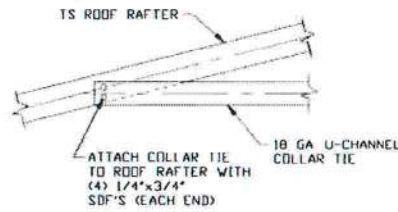

10

COLLAR TIE CONNECTION DETAIL

SCALE: NTS

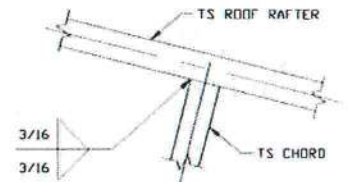

11

RAFTER TO CHORD CONNECTION DETAIL

SCALE: NTS

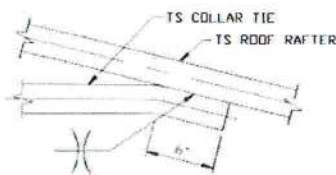

12

COLLAR TIE CONNECTION DETAIL

SCALE: NTS

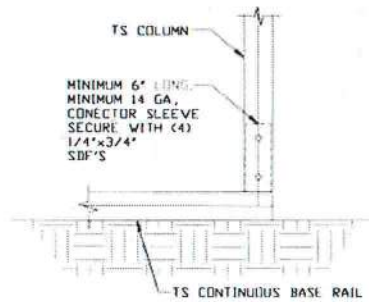

13

COLUMN/BASE RAIL CONNECTION DETAIL

SCALE: NTS

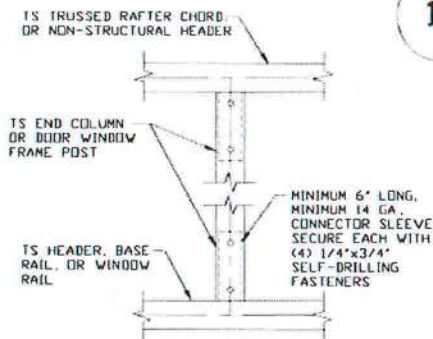

14

COLUMN TO HEADER OR BASE RAIL CONNECTION DETAIL

SCALE: NTS

**MOORE AND ASSOCIATES
ENGINEERING AND CONSULTING, INC.**

DRAWN BY: LT

CHECKED BY: PDH

PROJECT MGR: WSM

CLIENT: SBSI

STEEL BUILDINGS AND STRUCTURES, INC.
P.O. BOX 1287,
MOUNT AIRY, NC 27030
30'-0"x20'-0" ENCLOSED STRUCTURE

DATE: 12-11-20

SHT. 13

SCALE: NTS

DWG. NO: SK-3

JOB NO: 18068S/18156S

18290S/20019S/20324S

REV: 9

THIS DOCUMENT IS THE PROPERTY OF MOORE AND ASSOCIATES ENGINEERING AND CONSULTING. THE UNAUTHORIZED REPRODUCTION, COPYING, OR OTHERWISE USE OF THIS DOCUMENT IS STRICTLY PROHIBITED AND ANY INFRINGEMENT THEREUPON MAY BE SUBJECT TO LEGAL ACTION.

BOX EAVE RAFTER LEAN-TO OPTIONS

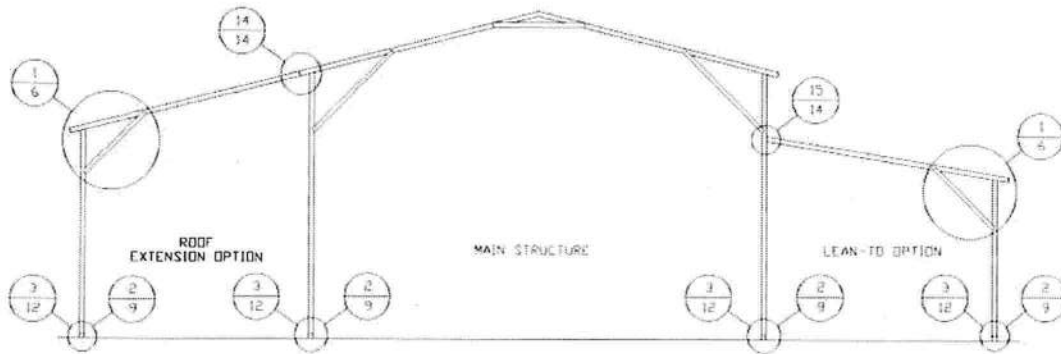

TYPICAL BOX EAVE RAFTER LEAN-TO OPTIONS FRAMING SECTION (BOTH OPTIONS SHOWN)

SCALE: NTS

MAXIMUM WIDTH OF SINGLE TS ROOF EXTENSION LEAN-TO IS 12'-0"

MAXIMUM WIDTH OF DOUBLE TS ROOF EXTENSION LEAN-TO IS 16'-0"

MAXIMUM SINGLE COLUMN HEIGHT FOR MAIN BUILDING WITH ROOF EXTENSION LEAN-TO ATTACHED IS 8'-0"
FOR COLUMN CONFIGURATIONS REFERENCE RAFTER COLUMN CONNECTION DETAILS.

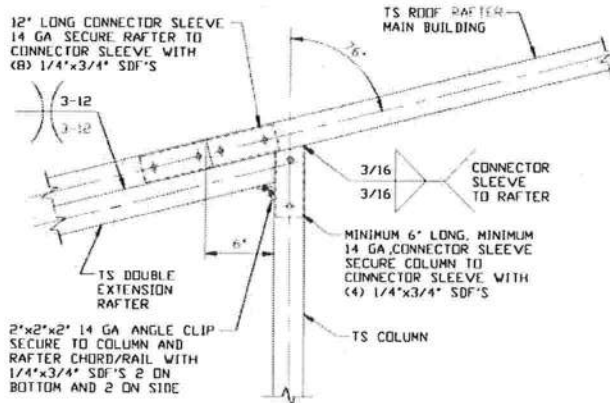

SIDE EXTENSION RAFTER/ COLUMN DETAIL FOR RAFTER SPANS 12'-0' < TO < 16'-0'

14

SCALE: NTS

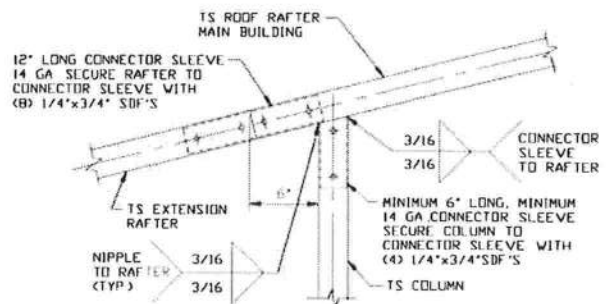

SIDE EXTENSION RAFTER/ COLUMN DETAIL FOR RAFTER SPANS < 12'-0'

14A

SCALE: NTS

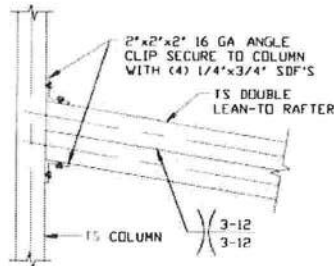

LEAN-TO RAFTER TO RAFTER POST CONNECTION DETAIL FOR WIDTHS 12'-0' < TO < 16'-0'

15

SCALE: NTS

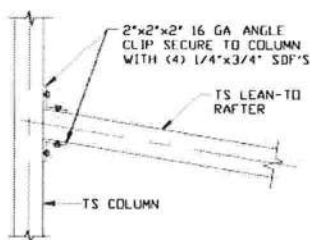

LEAN-TO RAFTER TO RAFTER POST CONNECTION DETAIL FOR WIDTHS < 12'-0'

15A

SCALE: NTS

**MOORE AND ASSOCIATES
ENGINEERING AND CONSULTING, INC.**

DRAWN BY: LT

CHECKED BY: PDH

PROJECT MGR: WSM

CLIENT: SBSI

STEEL BUILDINGS AND STRUCTURES, INC.
P.O. BOX 1287,
MOUNT AIRY, NC 27030
30'-0" x 20'-0" ENCLOSED STRUCTURE

DATE: 12-11-20

SHT. 14

SCALE: NTS

DWG. NO: SK-3

JOB NO: 18068S/18156S
18290S/20019S/20324S

REV: 9

THIS DOCUMENT IS THE PROPERTY OF MOORE AND ASSOCIATES ENGINEERING AND CONSULTING. THE UNAUTHORIZED REPRODUCTION, COPYING, OR OTHERWISE USE OF THIS DOCUMENT IS STRICTLY PROHIBITED AND ANY INFRINGEMENT THEREUPON MAY BE SUBJECT TO LEGAL ACTION.

BOW EAVE RAFTER LEAN-TO OPTIONS

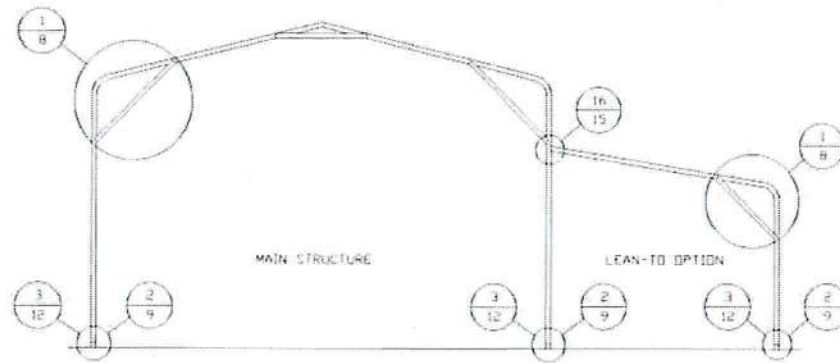

TYPICAL BOW EAVE RAFTER LEAN-TO OPTIONS FRAMING SECTION

SCALE: NTS
 MAXIMUM WIDTH OF SINGLE TS ROOF EXTENSION LEAN-TO IS 12'-0"
 MAXIMUM WIDTH OF DOUBLE TS ROOF EXTENSION LEAN-TO IS 16'-0"
 MAXIMUM SINGLE COLUMN HEIGHT FOR MAIN BUILDING WITH ROOF EXTENSION LEAN-TO ATTACHED IS 8'-0"
 FOR COLUMN CONFIGURATIONS REFERENCE RAFTER COLUMN CONNECTION DETAILS

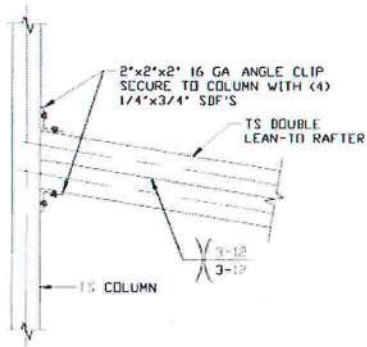

**LEAN-TO RAFTER TO
 RAFTER POST CONNECTION
 DETAIL FOR WIDTHS
 12'-0" < TO ≤ 16'-0"**

16

SCALE: NTS

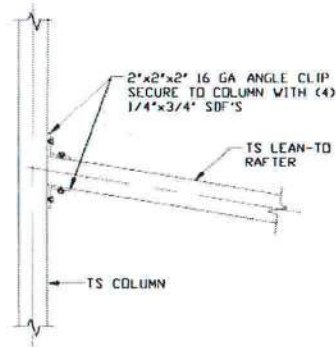

**LEAN-TO RAFTER
 TO RAFTER POST
 CONNECTION DETAIL
 FOR WIDTHS ≤ 12'-0"**

16A

SCALE: NTS

**MOORE AND ASSOCIATES
 ENGINEERING AND CONSULTING, INC.**

DRAWN BY: LT
 CHECKED BY: PDH
 PROJECT MGR: VSM
 CLIENT: SBSI

STEEL BUILDINGS AND STRUCTURES, INC.
 P.O. BOX 1287,
 MOUNT AIRY, NC 27030
 30'-0" x 20'-0" ENCLOSED STRUCTURE

THIS DOCUMENT IS THE PROPERTY OF MOORE AND ASSOCIATES ENGINEERING AND CONSULTING. THE UNAUTHORIZED REPRODUCTION, COPYING, OR OTHERWISE USE OF THIS DOCUMENT IS STRICTLY PROHIBITED AND ANY INFRINGEMENT THEREUPON MAY BE SUBJECT TO LEGAL ACTION.

DATE: 12-11-20
 SHT. 15

SCALE: NTS
 DWG. NO: SK-3

JOB NO: 18068S/18156S
 18290S/20019S/20324S
 REV: 9

OPTIONAL CONCRETE STRIP FOOTING

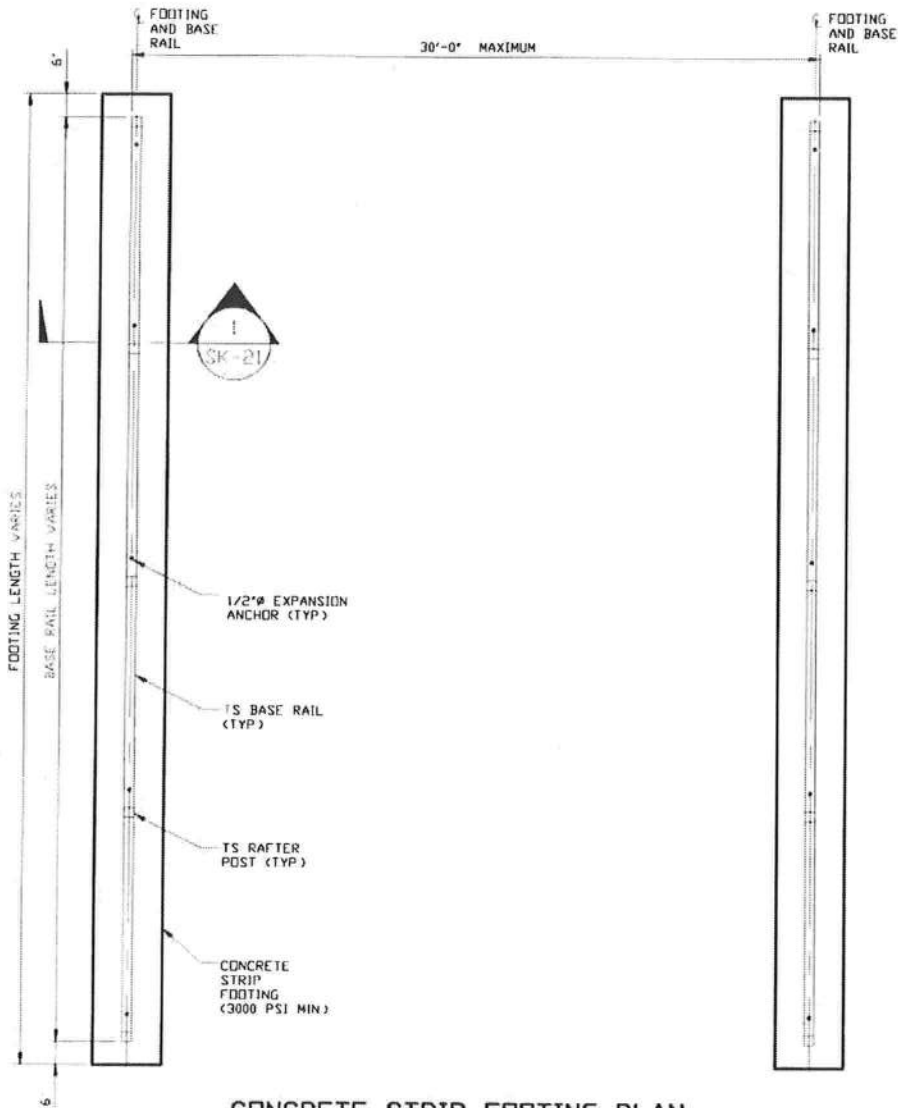

CONCRETE STRIP FOOTING PLAN
SCALE: NTS

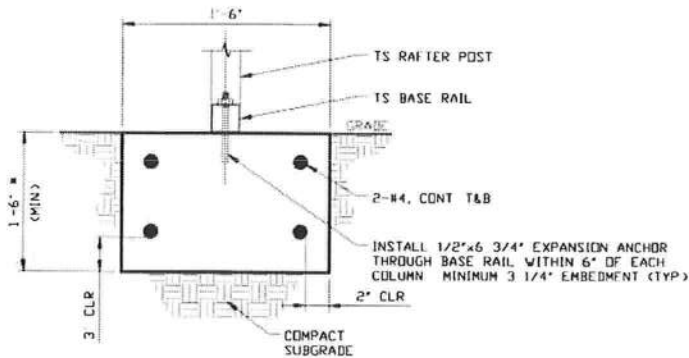

SECTION 1
SCALE: NTS
SK-21

* COORDINATE WITH LOCAL CODES/ORD

**MOORE AND ASSOCIATES
ENGINEERING AND CONSULTING, INC.**

DRAWN BY: LT

CHECKED BY: PDH

PROJECT MGR: WSH

CLIENT: SBSI

STEEL BUILDINGS AND STRUCTURES, INC.
P.O. BOX 1287,
MOUNT AIRY, NC 27030
30'-0" x 20'-0" ENCLOSED STRUCTURE

DATE: 12-11-20

SHT. 21

SCALE: NTS

DWG. NO: SK-3

**JOB NO: 18068S/18156S
18290S/20019S/20324S**

REV: 9

THIS DOCUMENT IS THE PROPERTY OF MOORE AND ASSOCIATES ENGINEERING AND CONSULTING. THE UNAUTHORIZED REPRODUCTION, COPYING, OR OTHERWISE USE OF THIS DOCUMENT IS STRICTLY PROHIBITED AND ANY INFRINGEMENT THEREUPON MAY BE SUBJECT TO LEGAL ACTION.

OPTIONAL BASE RAIL ON TIMBER BEAM WITH SOIL NAIL

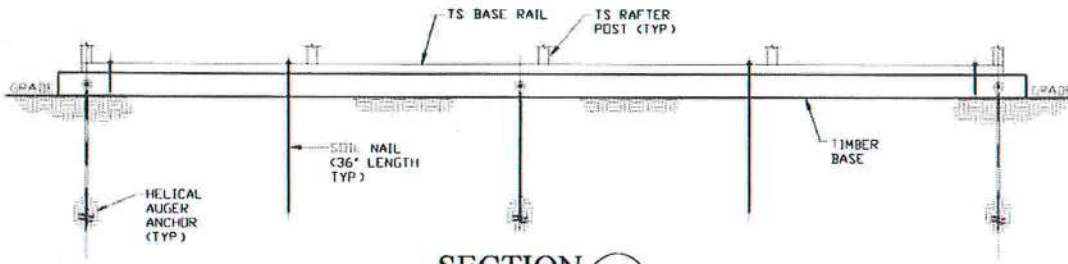

SECTION 2
SCALE: NTS

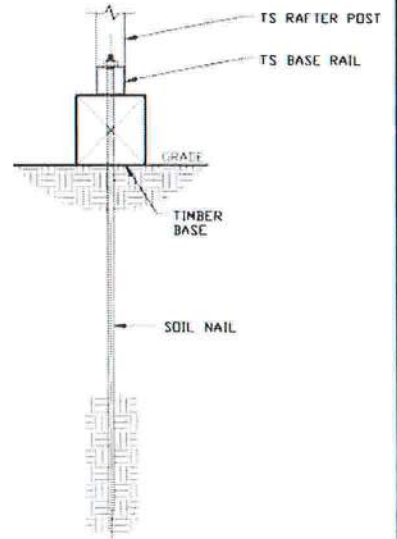
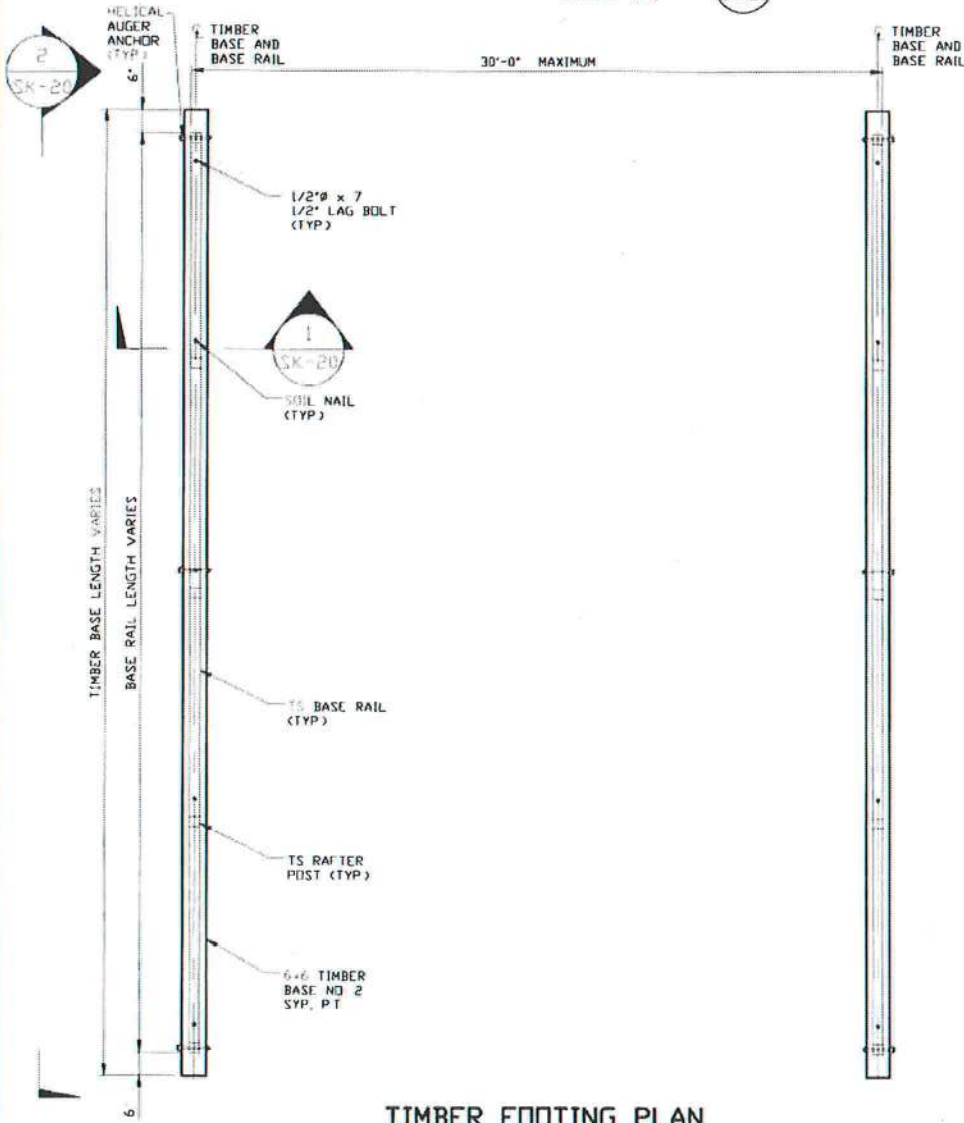

SECTION 1
SCALE: NTS

TIMBER FOOTING PLAN
SCALE: NTS

HELIX ANCHOR	
SIDE LENGTH	MAXIMUM SPACING
VARIES	10'-0" (EVERY OTHER POST)

**MOORE AND ASSOCIATES
ENGINEERING AND CONSULTING, INC.**

DRAWN BY: LT
CHECKED BY: PDH
PROJECT MGR: WSH
CLIENT: SBSI

STEEL BUILDINGS AND STRUCTURES, INC.
P.O. BOX 1287,
MOUNT AIRY, NC 27030
30'-0" x 20'-0" ENCLOSED STRUCTURE

THIS DOCUMENT IS THE PROPERTY OF MOORE AND ASSOCIATES ENGINEERING AND CONSULTING. THE UNAUTHORIZED REPRODUCTION, COPYING, OR OTHERWISE USE OF THIS DOCUMENT IS STRICTLY PROHIBITED AND ANY INFRINGEMENT THEREUPON MAY BE SUBJECT TO LEGAL ACTION.

DATE: 12-11-20	SCALE: NTS	JOB NO: 18068S/18156S 18290S/20019S/20324S
SHT. 20	DWG. NO: SK-3	REV. 9

OPTIONAL BASE RAIL ON TIMBER BEAM

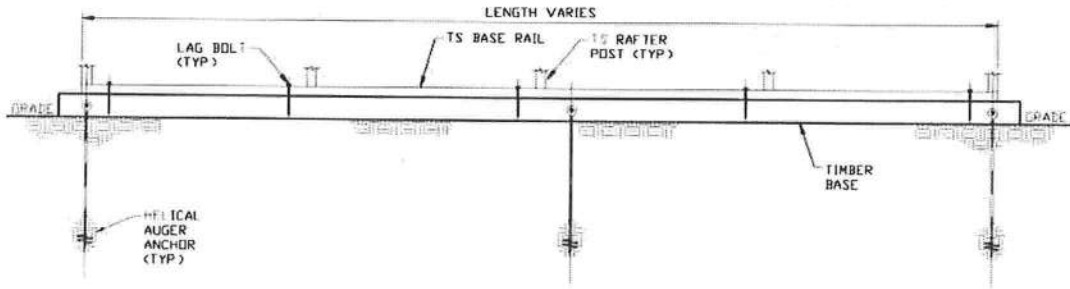

SECTION 2
SCALE: NTS

2
SK-19

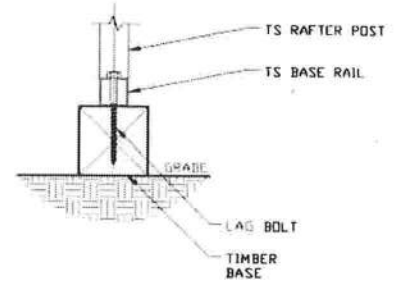

SECTION 1
SCALE: NTS

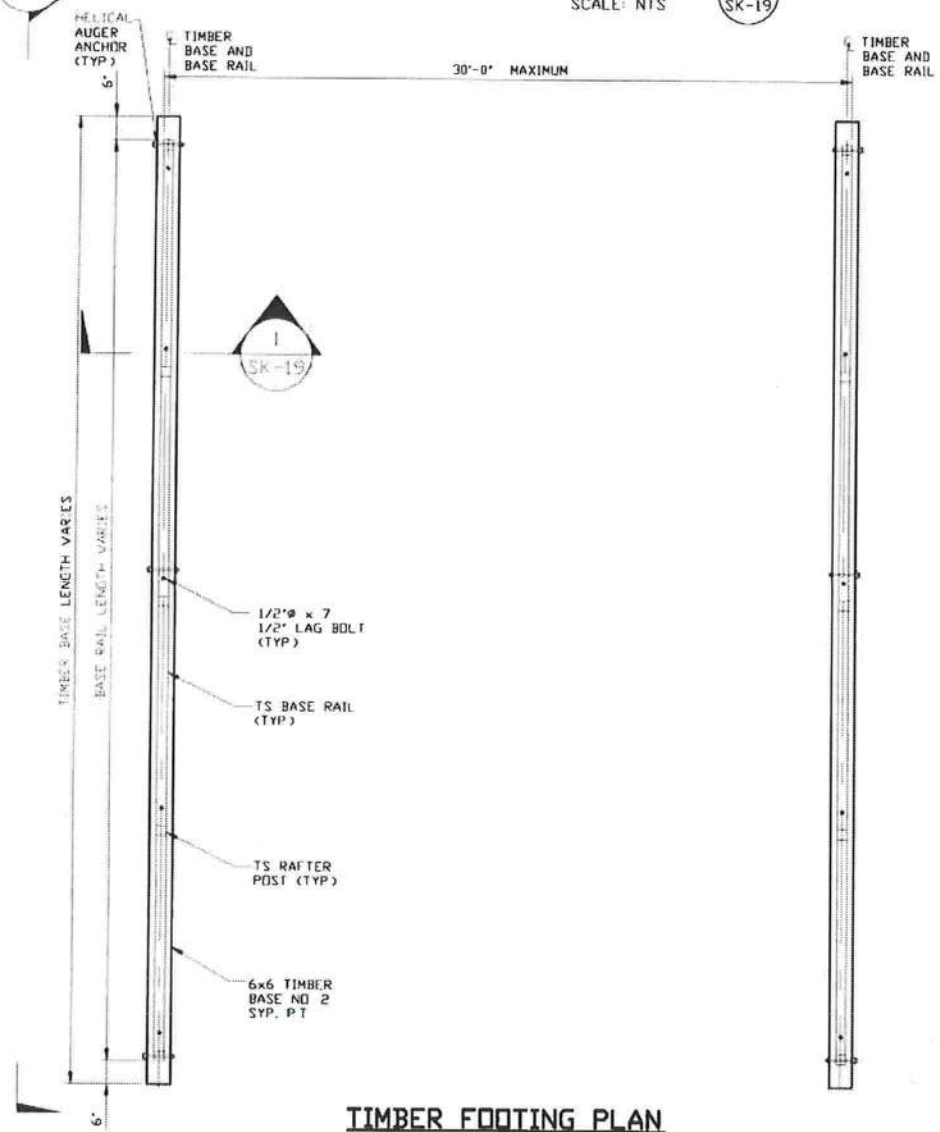

TIMBER FOOTING PLAN
SCALE: NTS

HELIX ANCHOR	
SIDE LENGTH	MAXIMUM SPACING
VARIES	10'-0" (EVERY OTHER POST)

**MOORE AND ASSOCIATES
ENGINEERING AND CONSULTING, INC.**

DRAWN BY: LT
CHECKED BY: PDH
PROJECT MGR: WSM
CLIENT: SBSI

STEEL BUILDINGS AND STRUCTURES, INC.
P.O. BOX 1287,
MOUNT AIRY, NC 27030
30'-0" x 20'-0" ENCLOSED STRUCTURE

DATE: 12-11-20	SCALE: NTS	JOB NO: 18068S/18156S	18290S/20019S/20324S
SHT. 19	DWG. NO: SK-3	REV: 9	

THIS DOCUMENT IS THE PROPERTY OF MOORE AND ASSOCIATES ENGINEERING AND CONSULTING. THE UNAUTHORIZED REPRODUCTION, COPYING, OR OTHERWISE USE OF THIS DOCUMENT IS STRICTLY PROHIBITED AND ANY INFRINGEMENT THEREUPON MAY BE SUBJECT TO LEGAL ACTION.

OPTIONAL BASE RAIL ON GRADE APPLICATION

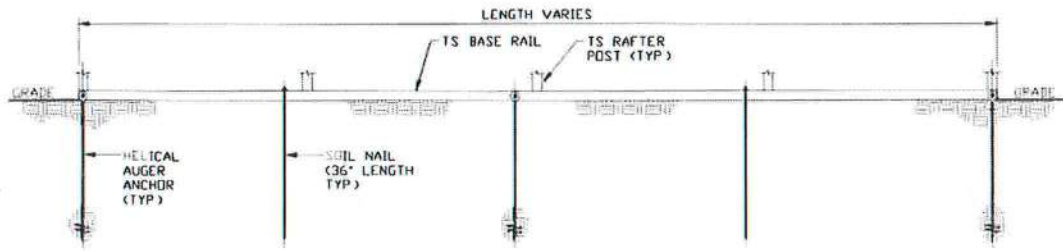

SECTION 2
SCALE: NTS (SK-18)

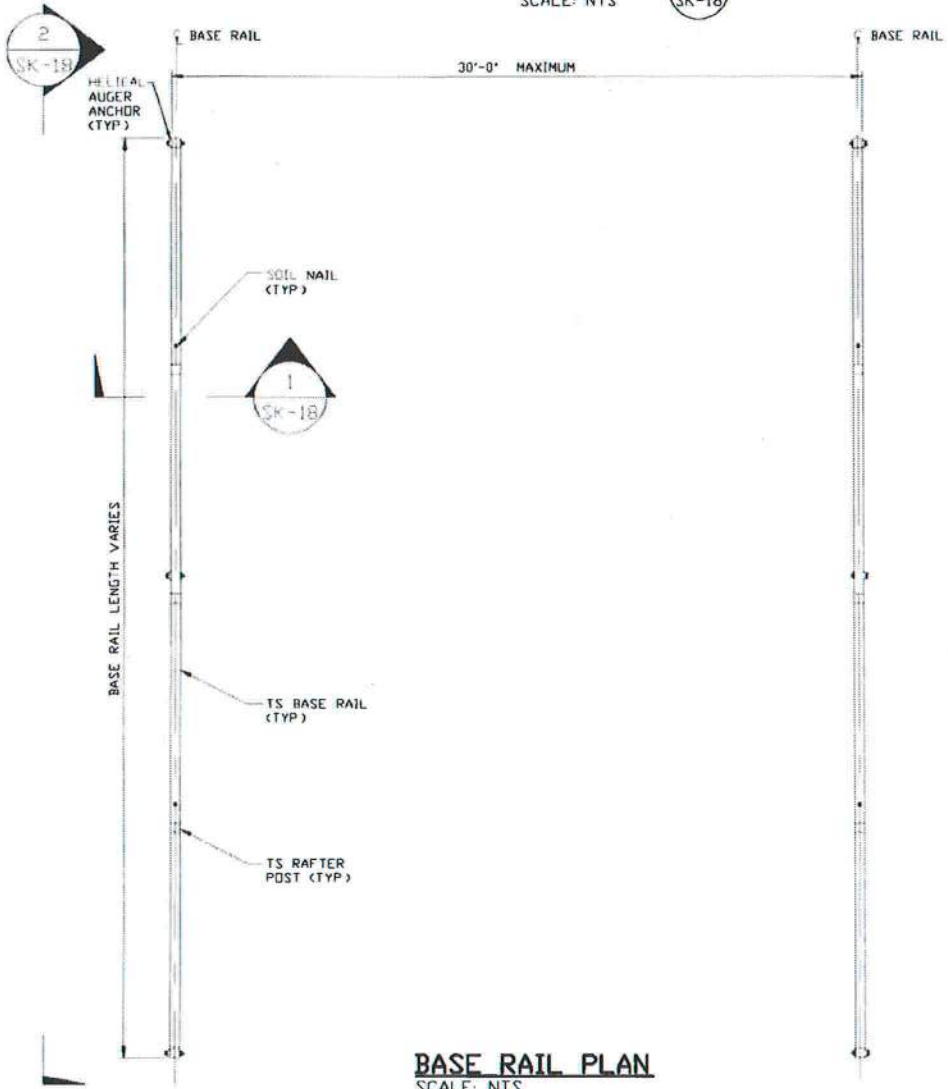

BASE RAIL PLAN
SCALE: NTS

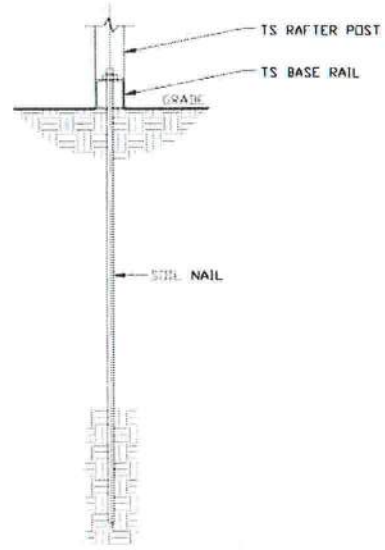

SECTION 1
SCALE: NTS (SK-18)

HELIX ANCHOR	
SIDE LENGTH	MAXIMUM SPACING
VARIES	10'-0" (EVERY OTHER POST)

**MOORE AND ASSOCIATES
ENGINEERING AND CONSULTING, INC.**

DRAWN BY: LT
CHECKED BY: PDH
PROJECT MGR: WSH
CLIENT: SBSI

STEEL BUILDINGS AND STRUCTURES, INC.
P.O. BOX 1287,
MOUNT AIRY, NC 27030
30'-0" x 20'-0" ENCLOSED STRUCTURE

THIS DOCUMENT IS THE PROPERTY OF MOORE AND ASSOCIATES ENGINEERING AND CONSULTING. THE UNAUTHORIZED REPRODUCTION, COPYING, OR OTHERWISE USE OF THIS DOCUMENT IS STRICTLY PROHIBITED AND ANY INFRINGEMENT THEREUPON MAY BE SUBJECT TO LEGAL ACTION.

DATE: 12-11-20	SCALE: NTS	JOB NO: 18068S/18156S 18290S/20019S/20324S
SHT. 18	DWG. NO: SK-3	REV.: 9

SIDE WALL HEADER OPTIONS

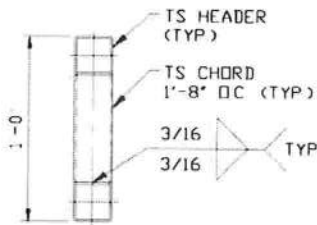

LACED HEADER DETAIL FOR DOOR OPENINGS 12'-0" < LENGTH < 20'-0"
SCALE: NTS

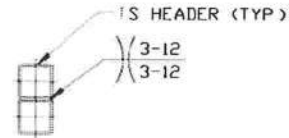

DOUBLE HEADER DETAIL FOR DOOR OPENINGS 7'-0" < LENGTH < 12'-0"
SCALE: NTS



SINGLE HEADER DETAIL FOR DOOR OPENINGS LENGTH < 7'-0"
SCALE: NTS

END WALL HEADER OPTIONS

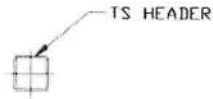

SINGLE HEADER DETAIL FOR DOOR OPENINGS LENGTH < 12'-0"
SCALE: NTS

**MOORE AND ASSOCIATES
ENGINEERING AND CONSULTING, INC.**

DRAWN BY: LT

CHECKED BY: PDH

PROJECT MGR: WSM

CLIENT: SBSI

STEEL BUILDINGS AND STRUCTURES, INC.
P.O. BOX 1287,
MOUNT AIRY, NC 27030
30'-0" x 20'-0" ENCLOSED STRUCTURE

DATE: 12-11-20

SHT. 17

SCALE: NTS

DWG. NO: SK-3

JOB NO: 18068S/18156S
18290S/20019S/20324S

REV: 9

THIS DOCUMENT IS THE PROPERTY OF MOORE AND ASSOCIATES ENGINEERING AND CONSULTING. THE UNAUTHORIZED REPRODUCTION, COPYING, OR OTHERWISE USE OF THIS DOCUMENT IS STRICTLY PROHIBITED AND ANY INFRINGEMENT THEREUPON MAY BE SUBJECT TO LEGAL ACTION.

BOX EAVE RAFTER VERTICAL ROOF/SIDING OPTION

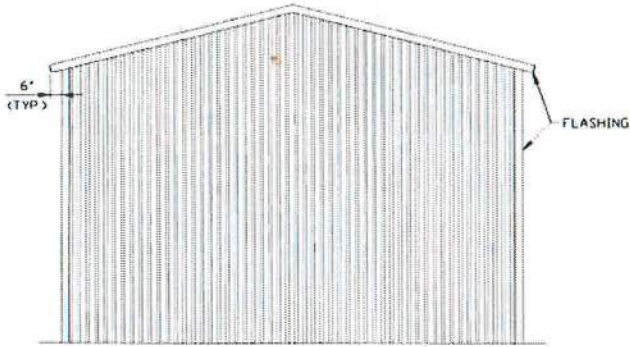

**TYPICAL END ELEVATION
VERTICAL ROOF/SIDING**
SCALE: NTS

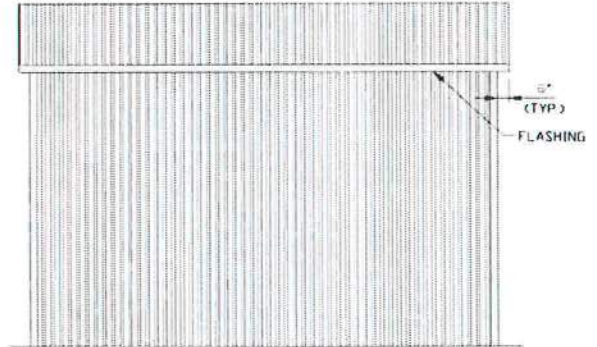

**TYPICAL SIDE ELEVATION
VERTICAL ROOF/SIDING**
SCALE: NTS

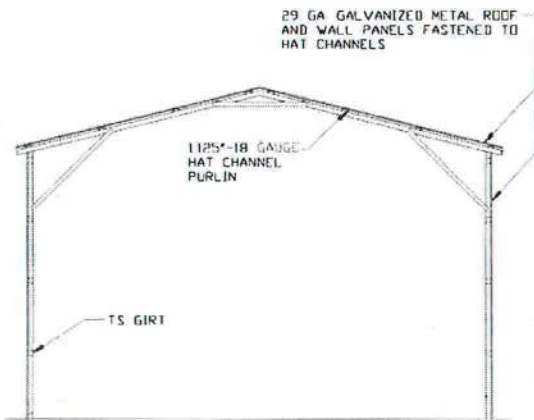

**TYPICAL SECTION
VERTICAL ROOF/SIDING OPTION**
SCALE: NTS

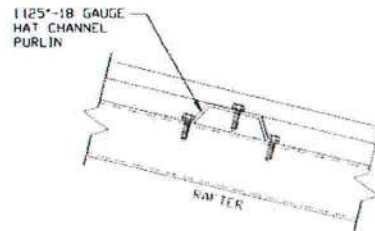

PANEL ATTACHMENT
(ALTERNATE FOR VERTICAL ROOF PANELS)
SCALE: NTS

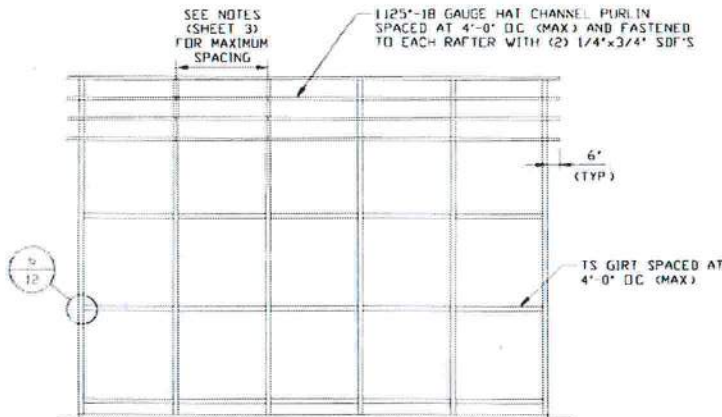

**TYPICAL FRAMING SECTION
VERTICAL ROOF/SIDING OPTION**
SCALE: NTS

**MOORE AND ASSOCIATES
ENGINEERING AND CONSULTING, INC.**

DRAWN BY: LT

CHECKED BY: PDH

PROJECT MGR: VSM

CLIENT: SBSI

STEEL BUILDINGS AND STRUCTURES, INC.
P.O. BOX 1287,
MOUNT AIRY, NC 27030
30'-0" x 20'-0" ENCLOSED STRUCTURE

DATE: 12-11-20

SHT. 16

SCALE: NTS

DWG. NO: SK-3

JOB NO: 18068S/18156S
18290S/20019S/20324S

REV. 9

THIS DOCUMENT IS THE PROPERTY OF MOORE AND ASSOCIATES ENGINEERING AND CONSULTING. THE UNAUTHORIZED REPRODUCTION, COPYING, OR OTHERWISE USE OF THIS DOCUMENT IS STRICTLY PROHIBITED AND ANY INFRINGEMENT THEREUPON MAY BE SUBJECT TO LEGAL ACTION.

Melissa Garber

From: Whitney Hodges <whodges@sbsihq.com>
Sent: Friday, May 20, 2022 8:13 AM
To: Melissa Garber; joshua.fryer@va.gov
Subject: Product Approval Information - Josh Fryer - 221 SW Hawaii Terrace

Steel Buildings & Structures, Inc. - AG Metal Roof - +16.0/-28.2 - FL22561.1
Steel Buildings & Structures, Inc. - AG Metal Wall - +16.0/-28.2 - FL22562.1
Janus International Group - Series 750 - +19.4/-22.7 - FL12765.8
MI Windows - Single Hung - +/-55 - FL17499.1
Elixir Door - Series 407 - +/-50 - FL17996.5

Please let me know if you need anything else!

--

DO NOT pour concrete prior to receiving an approved permit. Once the permit is approved, be sure to schedule your footing inspection.



Whitney Hodges
Permitting Department
Steel Buildings & Structures, Inc.
www.steelbuildingstructures.com
"THE COMPANY THAT BUILDS WITH PRIDE"
Phone: 877-272-8276 Ext:116

