

COLUMBIA COUNTY Property Appraiser

Parcel 14-3S-16-02123-044

Owners

ROBISON GERALD
ROBISON BRENDA
253 NW MELANIE WAY
LAKE CITY, FL 32055

GIS

Pictometry

Parcel Summary

Location	253 NW MELANIE WAY
Use Code	0100: SINGLE FAMILY
Tax District	3: COUNTY
Acreage	1.152
Township	3S
Range	16
Subdivision	CHADWORTH
Exemptions	01: HOMESTEAD (196.031a&b) (100%)

Legal Description

(AKA LOT 5 BLOCK F CHADWORTH S/D UNREC)
COMM NE COR OF NW1/4 OF SE1/4, RUN S 635.25 FT
FOR POB, CONT S 161.75 FT, W 310 FT, NORTH
161.75 FT, E 310 FT TO POB.

1158-492, WD 1153-1053, WD 1234-1591,
DC 1236-188, WD 1412-616, WD 1436-326,

Working Values

	2026
Total Building	\$235,393
Total Extra Features	\$5,350
Total Market Land	\$28,000
Total Ag Land	\$0

	2026
Total Market	\$268,743
Total Assessed	\$227,811
Total Exempt	\$51,411
Total Taxable	\$176,400
SOH Diff	\$40,932

Value History

	2025	2024	2023	2022	2021	2020
Total Building	\$234,044	\$222,019	\$205,381	\$179,645	\$153,243	\$117,913
Total Extra Features	\$5,350	\$5,350	\$5,350	\$5,350	\$5,350	\$5,350
Total Market Land	\$28,000	\$24,000	\$24,000	\$18,200	\$18,200	\$18,166
Total Ag Land	\$0	\$0	\$0	\$0	\$0	\$0
Total Market	\$267,394	\$251,369	\$234,731	\$203,195	\$176,793	\$141,429
Total Assessed	\$221,822	\$215,570	\$209,291	\$203,195	\$176,793	\$127,944
Total Exempt	\$50,722	\$50,000	\$50,000	\$50,000	\$0	\$100,500
Total Taxable	\$171,100	\$165,570	\$159,291	\$153,195	\$176,793	\$27,444
SOH Diff	\$45,572	\$35,799	\$25,440	\$0	\$0	\$13,485

Document/Transfer/Sales History

Instrument / Official Record	Date	Q/U	Reason	Type	V/I	Sale Price	Ownership
<u>WD</u> 1436/326	2021-04-26	<u>Q</u>	<u>01</u>	WARRANTY DEED	Improved	\$190,000	Grantor: MOSCHETTI NANCY E TRUSTEE Grantee: ROBISON GERALD
<u>WD</u> 1412/0616	2020-05-18	<u>U</u>	<u>30</u>	WARRANTY DEED	Improved	\$100	Grantor: NANCY E MUSCHETTI TRUSTEE Grantee: NANCY E MUSCHETTI TRUSTEE
<u>WD</u> 1234/1591	2012-05-09	<u>U</u>	<u>30</u>	WARRANTY DEED	Improved	\$100	Grantor: ROBERT S & NANCY E MUSCHETTI Grantee: ROBERT S & NANCY E MUSCHETTI AS CO- TRUSTEES
<u>WD</u> 1158/0492	2008-06-26	<u>Q</u>	<u>03</u>	WARRANTY DEED	Improved	\$100	Grantor: LOUIS SCHWARTZ Grantee: ROBERT S & NANCY E MUSCHETTI
<u>WD</u> 1153/1053	2008-06-26	<u>Q</u>		WARRANTY DEED	Improved	\$155,000	Grantor: LOUIS SCHWARTZ Grantee: ROBERT S & NANCY E MUSCHETTI

Buildings

Building # 1, Section # 1, 116588, SFR

Type	Style	Heated Sq Ft	Repl Cost New	YrBlt	Year Eff	Gross Area	Other % Dpr	Normal % Dpr	% Cond	Value
0100	01	1456	\$283,606	2008	2008	2,898	0.00%	17.00%	83.00%	\$235,393

Structural Elements

Type	Description	Code	Details
EW	Exterior Wall	32	HARDIE BRD
RS	Roof Structure	03	GABLE/HIP
RC	Roof Cover	03	COMP SHNGL
IW	Interior Wall	05	DRYWALL
IF	Interior Flooring	14	CARPET
IF	Interior Flooring	15	HARDTILE
AC	Air Conditioning	03	CENTRAL
HT	Heating Type	04	AIR DUCTED
BDR	Bedrooms	3.00	
BTH	Bathrooms	2.00	
FR	Frame	02	WOOD FRAME
STR	Stories	1.	1.
AR	Architectural Type	05	CONV

Sub Areas

Type	Gross Area	Percent of Base	Adjusted Area
BAS	1,456	100%	1,456
FEP	150	80%	120
FEP	300	80%	240
FGR	480	55%	264
FOP	200	30%	60
FOP	312	30%	94

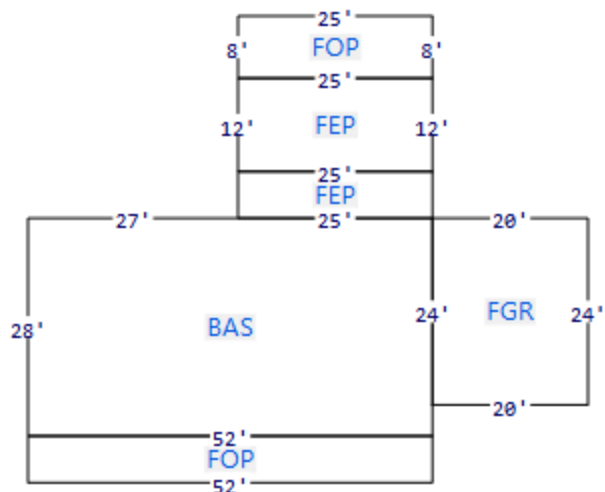

Extra Features

Code	Description	Length	Width	Units	Unit Price	AYB	% Good Condition	Final Value
0296	SHED METAL			1.00	\$0.00	2009	100%	\$1,800
0060	CARPORT F			1.00	\$0.00	2009	100%	\$800

Code	Description	Length	Width	Units	Unit Price	AYB	% Good Condition	Final Value
0296	SHED METAL			1.00	\$0.00	2009	100%	\$200
0070	CARPORT UF			1.00	\$0.00	2014	100%	\$750
0296	SHED METAL			1.00	\$0.00	2018	100%	\$1,000
0070	CARPORT UF			1.00	\$0.00	2018	100%	\$500
0252	LEAN-TO W/O FLOOR			1.00	\$0.00	2018	100%	\$300

Land Lines

Code	Description	Zone	Front	Depth	Units	Rate/Unit	Acreage	Total Adj	Value
0100	SFR	RSF/MH-1	162.00	310.00	2.00	\$14,000.00/LT	1.15	1.00	\$28,000

Personal Property

None

Permits

Date	Permit	Type	Status	Description
Sep 23, 2008	27207	SFR	COMPLETED	SFR
Sep 6, 2007	26084	SFR	COMPLETED	SFR

TRIM Notices

2025

2024

2023

Disclaimer

All parcel data on this page is for use by the Columbia County Assessor for assessment purposes only. The summary data on this page may not be a complete representation of the parcel or of the improvements thereon. Building information, including unit counts and number of permitted units, should be verified with the appropriate building and planning agencies. Zoning information should be verified with the appropriate planning agency. All parcels are reappraised each year. This is a true and accurate copy of the records of the Columbia County Assessor's Office as of April 27, 2026.