

THIS ITEM HAS BEEN DIGITALLY SIGNED AND SEALED BY KIMANDY LAWRENCE, PE ON THE DATE ADJACENT TO THE SEAL. PRINTED COPIES OF THIS DOCUMENT ARE NOT CONSIDERED SIGNED AND SEALED AND THE SIGNATURE MUST BE VERIFIED ON ANY ELECTRONIC COPIES.

HALEY, PATRICIA

EXISTING WITH NEW GRID-INTERACTIVE PHOTOVOLTAIC SYSTEM WITH NEW PARTIAL HOME BACKUP BATTERY ENERGY STORAGE SYSTEM DC SYSTEM SIZE (11.28KW)

GENERAL NOTES

SCOPE OF WORK

1. THE PROJECT IS EXISTING AND NEW PHOTOVOLTAIC SYSTEM CONSISTING OF SOLAR ARRAY(S) AND ASSOCIATED POWER CONDITIONING EQUIPMENT WITH BATTERY BACKUP SYSTEM.
2. ALL CONSTRUCTION SHALL COMPLY WITH THE ADOPTED EDITION OF THE FLORIDA BUILDING CODE AND NATIONAL ELECTRICAL CODE AS SPECIFIED IN THE PROJECT-SPECIFIC NOTES. ALL CONSTRUCTION SHALL ALSO COMPLY WITH ALL APPLICABLE CITY, COUNTY, STATE AND LOCAL ELECTRICAL UTILITY CODES, RULES AND REGULATIONS.
3. THE SYSTEM WILL BE INTERCONNECTED TO THE ELECTRICAL UTILITY GRID IN ACCORDANCE WITH THE REQUIREMENTS OF THE ADOPTED ELECTRIC AND THE ELECTRICAL UTILITY COMPANY.
4. THE CONTRACTOR SHALL PROVIDE LABOR FOR CONSTRUCTION OF THE ARRAY AND INSTALLATION OF ALL ELECTRICAL EQUIPMENT. THE CONTRACTOR WILL PROVIDE COMPETENT SUPERVISION FOR THE WORK TO BE ACCOMPLISHED. CONTRACTOR SHALL SUBMIT SHOP DRAWINGS FOR APPROVAL BY OWNER AS REQUESTED.
5. THERE WILL BE NO SUBMISSION FOR ANY EQUIPMENT WITH THE VENDOR PART NUMBER ON THE DRAWING WITHOUT WRITTEN APPROVAL OF THE PROFESSIONAL ENGINEER. COMMON ITEMS SUCH AS CONDUITS, WIRE, FITTINGS, ETC. ARE NOT SPECIFIED BY VENDOR BUT THE SIZES CANNOT BE REDUCED.
6. THE CONSTRUCTION CONTRACTOR AND HIS SUBCONTRACTORS AGREE THAT IN ACCORDANCE WITH THE GENERALLY ACCEPTED CONSTRUCTION PRACTICES CONSTRUCTION CONTRACTOR AND HIS SUBCONTRACTORS WILL BE REQUIRED TO ASSUME SOLE AND COMPLETE RESPONSIBILITY FOR THE SAFETY OF ALL PERSON AND PROPERTY, AND THAT THIS REQUIREMENT SHALL BE MADE TO APPLY CONTINUOUSLY AND IS NOT LIMITED TO NORMAL WORKING HOURS.
7. CONSTRUCTION CONTRACTOR AND HIS SUBCONTRACTORS FURTHER AGREE TO DEFEND, INDEMNIFY AND HOLD HARMLESS THE DESIGN PROFESSIONAL FROM ANY AND ALL LIABILITY, REAL OR ALLEGED, IN CONNECTION WITH THE PERFORMANCE OF WORK ON THIS PROJECT, EXCEPT LIABILITY ARISING FROM THE SOLE NEGLIGENCE OF THE DESIGN PERSONNEL.
8. CONSTRUCTION CONTRACTOR AND HIS SUBCONTRACTORS WILL BE REQUIRED TO REPAIR ANY DAMAGE DONE TO BUILDINGS, GROUNDS OR UTILITIES AT NO ADDITIONAL COST TO THE CUSTOMER. DEFECTIVE MATERIAL OR WORKMANSHIP WILL NOT BE ALLOWED ON THIS PROJECT. REASONABLE HOUSEKEEPING AND CLEAN UP SHALL BE CONDUCTED BOTH DURING THE EXECUTION OF AND AT THE CONCLUSION OF THE PROJECT.
9. CONTRACTOR SHALL LOCATE ALL POST TENSION CABLES ON CONCRETE ROOFS AND SHALL VERIFY THAT SUCH CABLES DO NOT INTERFERE WITH THE LOCATIONS OF FASTENERS AS SHOWN IN THE ATTACHMENT DETAILS.

GENERAL

1. THE ACTUAL SYSTEM EQUIPMENT SPECIFICATIONS FOR THE PHOTOVOLTAIC SYSTEM ARE INCLUDED IN THE PV SYSTEM SPECIFICATION ON THE TITLE PAGE AND THROUGHOUT THE DRAWING AS NECESSARY FOR CLARITY. IN ADDITION THE ACTUAL VENDOR SPECIFICATION DATA SHEETS WILL BE INCLUDED AS PART OF THE PERMIT SUBMITTAL.
2. ONLY NEW MATERIAL WILL BE INSTALLED AS PART OF THE PROJECT. ALL NEW INSTALLED EQUIPMENT WILL BE APPROPRIATELY LISTED AND NEMA RATED. ALL NEW EQUIPMENT SHALL HAVE PERMANENT PLASTIC ENGRAVED IDENTIFICATION TAGS INSTALLED.
3. ALL CUTTING AND PATCHING REQUIRED FOR INSTALLATION OF NEW RACEWAYS AND EQUIPMENT SHALL BE RESPONSIBILITY OF THE ELECTRICAL CONTRACTOR. ALL WORK SHALL BE PERFORMED BY TRADESMAN EXPERIENCED IN WORK REQUIRED. ALL FINISHES SHALL MATCH THE EXISTING ADJACENT FINISHES. OPENING IN FIRE RATED WALLS WILL BE PATCHED IN A MANNER MAINTAINING THE ORIGINAL FIRE AND SMOKE RATING.
4. DRAWINGS ARE DIAGRAMMATIC IN NATURE AND CANNOT SHOW EVERY CONNECTION, JUNCTION BOX, WIRE, CONDUIT, ETC. THE CONTRACTOR SHALL BE RESPONSIBLE FOR PROVIDING A COMPLETE AND FUNCTIONAL ELECTRICAL SYSTEM.
5. CONTRACTOR SHALL COORDINATE ALL POWER OUTAGES WITH THE OWNER'S REPRESENTATIVE IN ADVANCE.
6. PANEL DESIGNATIONS SHOWN ON THESE DRAWINGS ARE GIVEN FOR CLARIFICATION OF THE CIRCUITING ONLY AND MAY NOT CORRESPOND TO THE DESIGNATIONS FOUND IN THE FIELD.
7. ELECTRICAL TESTING SHALL BE IN COMPLIANCE WITH NFPA 70E.
8. SMOKE ALARMS SHALL BE INSTALLED INSIDE ALL SLEEPING ROOMS AND OUTSIDE EACH SEPARATE SLEEPING AREA IN THE IMMEDIATE VICINITY OF BEDROOMS. ADDITIONALLY, EACH STORY WITHIN THE DWELLING, INCLUDING BASEMENTS AND HABITABLE ATTICS, SHALL CONTAIN A SMOKE ALARM. SMOKE ALARMS SHALL BE INTERCONNECTED IN SUCH A MANNER THAT THE ACTIVATION OF ONE ALARM WILL ACTIVATE ALL OF THE ALARMS IN THE INDIVIDUAL UNIT. PHYSICAL INTERCONNECTION OF SMOKE ALARMS SHALL NOT BE REQUIRED WHERE LISTED WIRELESS ALARMS ARE INSTALLED AND ALL ALARMS SOUND UPON ACTIVATION OF ONE ALARM. INSTALL CARBON MONOXIDE ALARMS WITHIN 10 FEET OF EACH ROOM USED FOR SLEEPING PURPOSES WHEN THE HOME CONTAINS AN ATTACHED GARAGE OR FUEL-BURNING APPLIANCES. SMOKE ALARMS AND CARBON MONOXIDE ALARMS THAT ARE NOT HARDWIRED SHALL BE POWERED BY 10-YEAR, NON-REMOVABLE BATTERIES. FBCR 314.3, FBCR 314.6 [EXCEPTION 2], FBCR 315.1.

CONDUIT AND WIRE

1. ALL EXISTING CONDUIT RUNS ARE NOT SHOWN. CONTRACTOR SHALL VERIFY EXISTING CONDUIT LOCATIONS IN FIELD.
2. ALL CONDUCTORS SHALL BE INSTALLED IN A RACEWAY AS SPECIFIED IN THE DRAWINGS. THE EXCEPTION IS PV SOURCE CIRCUIT CONDUCTORS MADE OF PV WIRE CABLE. THESE CONDUCTORS MAY BE EXPOSED WITHIN THE PV ARRAY.
3. INDOOR EMT FITTINGS MAY BE COMPRESSION TYPE OR STEEL SET SCREW TYPE. OUTDOOR EMT FITTINGS MUST BE COMPRESSION RAIN-TIGHT TYPE.
4. A PULL ROPE SHALL BE INSTALLED IN ALL EMPTY CONDUITS.
5. CONDUCTORS MATERIAL, EITHER COPPER OR ALUMINUM IN SPECIFIED IN THE DRAWINGS. CONDUCTOR INSULATION TYPE SHALL BE THWN - 2 UNLESS OTHERWISE NOTED.

EQUIPMENT

1. ALL ELECTRICAL COMPONENTS INSTALLED OUTDOORS, EXPOSED TO WEATHER OR IN DAMP LOCATIONS SHALL BE RATED FOR NEMA 3R OR GREATER. INSTALLATION OF THESE COMPONENTS MUST COMPLY WITH THE MANUFACTURER'S INSTALLATION INSTRUCTIONS.
2. ALL RACEWAYS, CABINETS, BOXES, FIXTURES SHALL BE SUPPORTED FROM THE BUILDING STRUCTURE IN AN APPROVED MANNER.
3. AT THE COMPLETION OF THE PROJECT NEATLY TYPED ACCURATE PANEL BOARD DIRECTORIES INDICATING ALL BRANCH CIRCUITS AND SPARES WILL BE PROVIDED. ALL SPARES SHALL BE LEFT IN THE OFF POSITION.
4. ALL SAFETY SWITCHES SHALL BE HEAVY DUTY TYPE WITH COVER INTERLOCK AND HANDLE LOCK OFF PROVISIONS. SWITCHES SHALL BE MANUFACTURED BY A COMPANY CONSISTENT WITH OTHER INSTALLED EQUIPMENT WHENEVER POSSIBLE. PART NUMBERS, RATING AND FUSING SHALL BE AS SHOWN ON THE DRAWINGS.
5. CONTRACTOR SHALL ENSURE ALL NEC AND MAINTENANCE CLEARANCE REQUIREMENTS ARE MET FOR NEW EQUIPMENT AND MAINTAINED FOR EXISTING EQUIPMENT.
6. CONTRACTOR SHALL FIELD VERIFY EQUIPMENT CLEARANCE AND PLACEMENTS WHILE COORDINATING LOCATORS WITH OTHER TRADES, CONSTRUCTION MANAGERS, AND SITE SUPERVISORS PRIOR TO PURCHASING AND INSTALLING EQUIPMENT.
7. EVERY STRUCTURE AND PORTION THEREOF, INCLUDING NONSTRUCTURAL COMPONENTS THAT ARE PERMANENTLY ATTACHED TO STRUCTURES AND THEIR SUPPORTS AND ATTACHMENTS, SHALL BE DESIGNED AND CONSTRUCTED TO RESIST THE EFFECTS OF EARTHQUAKE MOTIONS IN ACCORDANCE WITH ASCE 7, EXCLUDING CHAPTER 14 AND APPENDIX 11A. THE SEISMIC DESIGN CATEGORY FOR A STRUCTURE IS PERMITTED TO BE DETERMINED IN ACCORDANCE WITH SECTION 1613 OR ASCE 7.
8. ALL CONTROLS AND SWITCHES INTENDED TO BE USED BY THE OCCUPANT OF THE ROOM OR AREA TO CONTROL LIGHTING AND RECEPTACLE OUTLETS, APPLIANCE AND COOLING, HEATING AND VENTILATING EQUIPMENT, SHALL BE LOCATED NO MORE THAN 48 INCHES MEASURED FROM THE TOP OF THE JUNCTION OR DEVICE BOX NOR LESS THAN 15 INCHES MEASURED TO THE BOTTOM OF THE JUNCTION OR DEVICE BOX ABOVE THE FINISHED FLOOR.
9. ALL RECEPTACLE OUTLETS ON BRANCH CIRCUITS OF 30 - AMPERES OR LESS AND COMMUNICATION SYSTEM RECEPTACLES SHALL BE LOCATED NO MORE THAN 48 INCHES MEASURED FROM THE TOP OF THE RECEPTACLE OUTLET BOX OR RECEPTACLE HOUSING NOR LESS THAN 15 INCHES MEASURED TO THE BOTTOM OF THE RECEPTACLE OUTLET BOX OR RECEPTACLE HOUSING ABOVE FINISHED FLOOR.

GROUNDING

1. THE GROUNDING SYSTEM SHALL MEET THE REQUIREMENTS OF THE NEC AND THE LOCAL ADOPTED CODE. ALL ELECTRICAL EQUIPMENT AND RACEWAYS SHALL BE PROPERLY GROUNDED.
2. AN INSULATED EQUIPMENT GROUNDING CONDUCTOR, IN ACCORDANCE WITH NEC CODE, SHALL BE PROVIDED IN ALL CONDUITS WITH CURRENT CARRYING CONDUCTORS. ALL LUGS AND CONNECTORS SHALL BE RATED FOR THE CONDUCTOR MATERIAL AND THE CONDITIONS OF USE.
3. THE GROUNDING RESISTIVITY WILL BE TESTED AFTER INSTALLATION TO CONFIRM 5 OHM OR LESS RESISTANCE FROM RACKING TO GROUND. IF GROUND RESISTANCE IS GREATER THAN 5 OHMS ADDITIONAL GROUNDING WILL BE INSTALLED UNTIL RESISTANCE IS LESS THAN 5 OHMS.

WIRING DEVICES

1. RECEPTACLES SHALL BE AS DESIGNED ON THE DRAWINGS AND SHOULD BE A BRAND CONSISTENT WITH OTHERS IN THE VICINITY WHENEVER POSSIBLE.
2. ALL WIRING DEVICES SHALL BE PROVIDED WITH APPROPRIATE COVER-PLATES. ANY EMPTY BOXES SHALL HAVE BLANK COVER PLATES. COVER-PLATES SHALL BE LEXAN, PLASTIC OR STAINLESS STEEL IN FINISHED AREA. GALVANIZED COVER-PLATES MAY BE USED IN EQUIPMENT ROOMS.

LABELING AND PHASING

1. FOR LABELING USE NUMBERED UV RATED LABELS TO INDICATE STRING NUMBER.
2. AS A SUBSTITUTE FOR LABELS YELLOW TAPE MAY BE USED FOR PHASING.
3. EACH METHOD DESCRIBED ABOVE WILL NEED TO BE PERFORMED ON BOTH POSITIVE AND NEGATIVE AT POINTS WHERE CONDUCTORS ARE TERMINATED.

SYSTEM DETAILS

DESCRIPTION	EXISTING SYSTEM COMBINE WITH NEW GRID-INTERACTIVE PHOTOVOLTAIC SYSTEM WITH NEW PARTIAL HOME BATTERY ENERGY STORAGE SYSTEM.
DC RATING OF SYSTEM	SYSTEM SIZE : 11.28 KW DC STC
AC RATING OF SYSTEM	11.5 KW
MAX. AC OUT. CURRENT	48 A
NO. OF NEW MODULES	(06) ZXM8-GPLDD132-720W ZNSHINE SOLAR MODULE
NO. OF EXISTING MODULE	(E)(24) Q.PEAK BLK-G4.1 290W Q.CELL SOLAR MODULE
NO. OF INVERTERS	(1) FRANKLIN APOWER S
NO. OF RSS	(30) TIGO TS4-A-F
ARRAY STRINGING	(1) BRANCH OF 06 MODULES
UTILITY COMPANY	GRU UTILITY
AC GROSS POWER RATING (GPR)	11.28 KW
PV SYSTEM TIER	II (10 KW AC < GPR ≤ 100 KW AC)

SITE DETAILS

ASHRAE EXTREME LOW	5°C
ASHRAE 2% HIGH	34°C
GROUND SNOW LOAD	3 PSF
WIND SPEED	120 MPH (ASCE 7-22)
RISK CATEGORY	II
WIND EXPOSURE CATEGORY	C

GOVERNING CODES

FLORIDA RESIDENTIAL CODE, 8TH EDITION 2023 (FRC)
FLORIDA BUILDING CODE, 8TH EDITION 2023 (FBC)
FLORIDA FIRE PREVENTION CODE, 8TH EDITION 2023 (FFPC)
NATIONAL ELECTRICAL CODE, NEC 2020 CODE BOOK

SHEET INDEX

SHEET NO.	SHEET NAME
PV-1	COVER PAGE
PV-2	FIRE SAFETY PLAN
PV-3	ELECTRICAL LINE DIAGRAM
PV-4	ELECTRICAL CALCULATIONS
PV-5	ELEVATION VIEW
PV-6	LABELS
PV-7	RACKING LAYOUT
PV-8	STRUCTURAL DETAILS
PV-9	WIND LOAD CALCULATION
PV-10 & PV-10.1	MODULE DATASHEET
PV-11	INVERTER DATASHEET
PV-12	RSS DATASHEET
PV-13	TRANSMITTER DATASHEET
PV-14	GATEWAY DATASHEET
PV-15	RACKING DATASHEET
PV-16	ATTACHMENT DATASHEET
PV-17	GROUNDING AND BONDING DATASHEET

SITE MAP (N.T.S)



VICINITY MAP

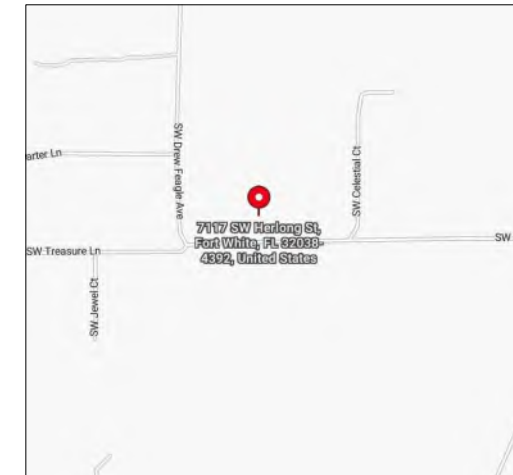

WIND FLOW MAP

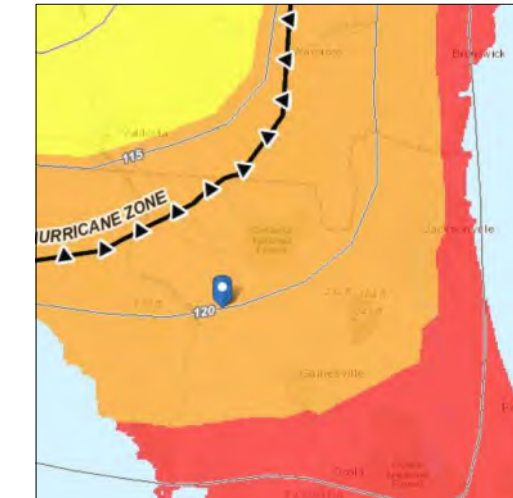

BUILDING DEPARTMENT SEAL STAMP



CONTACT: (561) 660-5200
6801 LAKE WORTH ROAD SUITE 302
LAKE WORTH, FL 33467
FLORIDA REGISTRY# 33809



CONTACT: (352) 554-7033
4509 NORTHWEST 23RD AVENUE,
GAINESVILLE, FL, 32606
SOLAR CONTRACTOR LICENSE: CVC56761

HALEY, PATRICIA

7115 SOUTHWEST HERLONG STREET, FORT WHITE, FL, 32038
29.986761, -82.742427

SIGNATURE WITH SEAL

COVER PAGE

PV-1

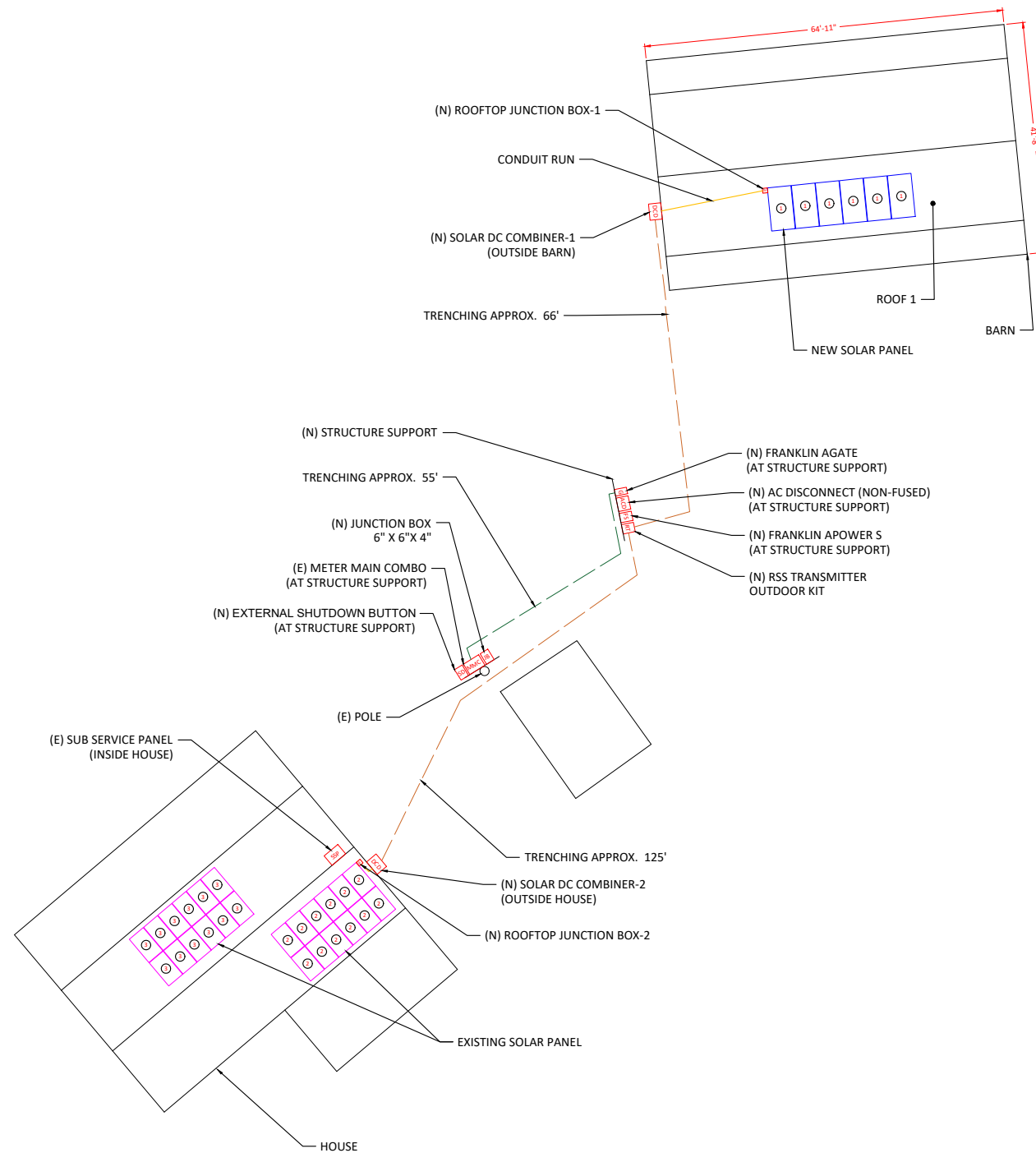

BUILDING DEPARTMENT SEAL STAMP



CONTACT: (561) 660-5200
6801 LAKE WORTH ROAD SUITE 302
LAKE WORTH, FL 33467
FLORIDA REGISTRY# 33809



CONTACT: (352) 554-7033
4509 NORTHWEST 23RD AVENUE,
GAINESVILLE, FL, 32606
SOLAR CONTRACTOR LICENSE: CVC56761

HALEY, PATRICIA

7115 SOUTHWEST HERLONG
STREET, FORT WHITE, FL, 32038
29.986761, -82.742427

SIGNATURE WITH SEAL

FIRE SAFETY PLAN

PV-2

EQUIPMENT SPECIFICATIONS

EQUIPMENT	DESCRIPTION	QUANTITY
(N) MODULE	ZXM8-GPLDD132-720W ZNSHINE SOLAR MODULE	06
(E) MODULE	Q.PEAK BLK-G4.1 290W Q.CELL SOLAR MODULE	24
INVERTER	FRANKLIN APOWER S	1
JUNCTION BOX	(8"X8"X3")GENERIC, NEMA 3R	2
NO. OF RSS	TIGO TS4-A-F	30
AC DISCONNECT	PV AC DISCONNECT 240V, 60 AMP, NON-FUSED, NEMA 3R, UL LISTED	1
ATTACHMENT	S-5! SOLARFOOT	14
RACKING SYSTEM	IRONRIDGE (XR100) RAILS	-

SYSTEM INFORMATION

DC SYSTEM SIZE	11.28 KW
AC SYSTEM SIZE	11.5 KW

ROOF SPECIFICATIONS

ROOF MATERIAL	TRAPEZOIDAL ROOF
ROOF CONDITION	GOOD

EXISTING ROOF INFORMATION

ROOF	QUANTITY	SLOPE	AZIMUTH
ROOF 1	06	14°(3/12)	175°

NOTE:

THIS PROPERTY HAS AN EXISTING SOLAR SYSTEM. THE CURRENT INVERTER IS TO BE REMOVED, WHILE THE EXISTING SOLAR PANELS WILL REMAIN IN PLACE TO BE OPERATED WITH THE NEW INVERTER.

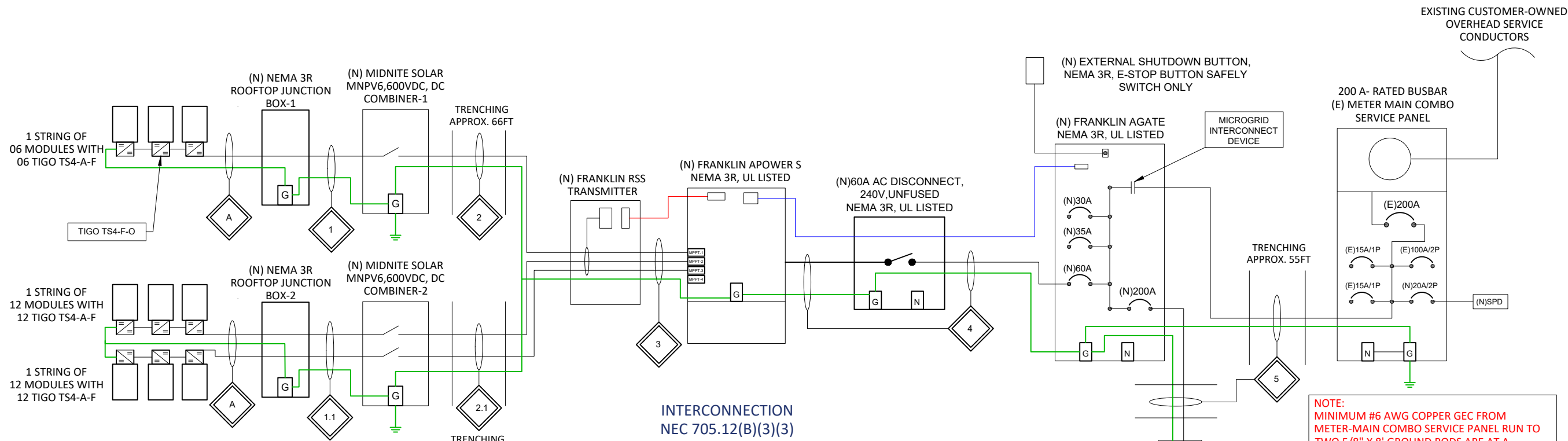

NOTE:
MINIMUM #6 AWG COPPER GEC FROM DC COMBINER PER 250.166 AND 250.120(C).

- ENERGY STORAGE SYSTEM NOTES :**
1. THE OVERCURRENT PROTECTION DEVICE OF ANY INDIVIDUAL LOAD FED BY THE ENERGY STORAGE SYSTEM SHALL NOT EXCEED AN AMPACITY OF 60A OR A NAMEPLATE POWER RATING OF 11.52KW.
 2. IF THE UTILITY IS DOWN, THE FRANKLIN AGATE ISOLATES THE PV ENERGY STORAGE AND UNINTERRUPTIBLE LOADS.
 3. IF THE UTILITY IS DOWN, THE BACKUP SYSTEM OPERATES AS A STAND-ALONE SYSTEM UNDER THE CONDITIONS OF NEC ARTICLES 706 AND 710.
 4. ALL METAL ENCLOSURES, RACEWAYS, CABLES AND EXPOSED NON-CURRENT-CARRYING METAL PARTS EQUIPMENT SHALL BE GROUNDED TO EARTH AS REQUIRED BY NEC 250.
 5. EQUIPMENT GROUNDING CONDUCTORS SHALL BE SIZED ACCORDING TO NEC 690.45.
 6. PV SYSTEM INTERCONNECTED ON THE LOAD SIDE OF MAIN DISCONNECTING MEANS PER NEC 705.12(B).
 7. THE OVERCURRENT PROTECTION DEVICE OF ANY INDIVIDUAL LOAD WITH AN AMPACITY RATING GREATER THAN 60A OR A NAMEPLATE POWER RATING OF 11.52KW SHALL REQUIRE INSTALLATION OF AUXILIARY CONTACTORS TO SHED LOADS.
 8. THE DWELLING IS EQUIPPED WITH EXISTING INTERCONNECTED SMOKE ALARMS INSTALLED THROUGHOUT ALL REQUIRED AREAS, INCLUDING HABITABLE SPACES, HALLWAYS, AND THE ATTACHED GARAGE, IN COMPLIANCE WITH NFPA 855 (2020) SECTION 15.9.1.

**INTERCONNECTION
NEC 705.12(B)(3)(3)**

SUM OF ALL SUPPLIES AND LOADS EXCLUDING THE OVERCURRENT DEVICE PROTECTING THE BUSBAR:
100A+15A+15A+60A = 190A

BUS BAR RATING = 200A

INTERCONNECTION NOTE:
THE SUM OF THE OVERCURRENT DEVICES IN THE METER MAIN AND THE SOLAR OCPD SHALL NOT EXCEED THE BUSBAR RATING PER NEC 705.12(B)(3)(3) SUM OF THE EXISTING BREAKERS (100+15+15)A + SOLAR (60)=190A<200A.

NOTE:
MINIMUM #6 AWG COPPER GEC FROM METER-MAIN COMBO SERVICE PANEL RUN TO TWO 5/8" X 8" GROUND RODS ARE AT A MINIMUM SEPARATION OF 6'. BOND TO COLD WATER PIPE AND INTER-SYSTEM BONDING JUMPER PER NEC 250.66(A) AND 250.52 (A)(5).

CONDUCTOR AND CONDUIT SCHEDULE

SR. NO.	DESCRIPTION	CONDUIT SIZE
(A)	PV WIRES, (1) #10 AWG THWN-2 (G)	
(1)	(1) #10 AWG THWN-2 (DC+), (1) #10 AWG THWN-2 (DC-), (1) #10 AWG THWN-2 (G)	IN 3/4" CONDUIT RUN
(1.1)	(2) #10 AWG THWN-2 (DC+), (2) #10 AWG THWN-2 (DC-), (1) #10 AWG THWN-2 (G)	IN 3/4" CONDUIT RUN
(2)	(1) #8 AWG THWN-2 (DC+), (1) #8 AWG THWN-2 (DC-), (1) #10 AWG THWN-2 (G)	IN 3/4" CONDUIT RUN
(2.1)	(2) #8 AWG THWN-2 (DC+), (2) #8 AWG THWN-2 (DC-), (1) #10 AWG THWN-2 (G)	IN 3/4" CONDUIT RUN
(3)	(3) #10 AWG THWN-2 (DC+), (3) #10 AWG THWN-2 (DC-), (1) #10 AWG THWN-2 (G)	IN 3/4" CONDUIT RUN
(4)	(3) #6 AWG THWN-2 (L1,L2,N), (1) #10 AWG THWN-2 (G)	IN 1" CONDUIT RUN
(5)	(3) #2/0 AWG THWN-2 (L1,L2,N), (1) #6 AWG THWN-2 (G)	IN 2" CONDUIT RUN
(6)	(E)(3) #2/0 AWG THWN-2 (L1,L2,N), (E)(1) #6 AWG THWN-2 (G)	EXISTING CONDUIT RUN

RSS SPECIFICATION	
MANUFACTURER	TIGO
MODEL NO.	TS4-A-F
MAXIMUM SYSTEM VOLTAGE	1000V
NOMINAL INPUT DC CURRENT RATING	15A
MAXIMUM INPUT SHORT CIRCUIT CURRENT	20A
MAXIMUM INPUT VOLTAGE	80VDC
TOTAL QUANTITY	30

FRANKLIN GATEWAY SPECIFICATION	
MANUFACTURER	FRANKLIN
MODEL NO.	AGATE X
NOMINAL GRID VOLTAGE	120/240 V
CONTINUOUS CURRENT RATING	200A
FREQUENCY	60 HZ
ENCLOSURE RATING	NEMA 3R
TOTAL QUANTITY	01

NEW MODULE SPECIFICATION		
	NEW	EXISTING
MANUFACTURER	ZNSHINE SOLAR	Q.CELLS
MODEL NO.	ZXM8-GPLDD132	Q.PEAK BLK-G4.1
PEAK POWER (Pmpp)	720W	290W
PEAK VOLTAGE (Vmpp)	41.30V	31.96V
PEAK CURRENT (Impp)	17.44A	9.07A
OPEN CIRCUIT VOLTAGE (Voc)	49.1V	39.19V
SHORT CIRCUIT CURRENT (Isc)	18.43A	9.63A
TOTAL QUANTITY	06	24

INVERTER + BATTERY SPECIFICATIONS	
MANUFACTURER	FRANKLIN
MODEL NO.	APOWER S
MAX DC INPUT VOLTAGE	600 V
MAX OUTPUT POWER	11.5 KW
NOMINAL AC OUTPUT VOLTAGE	240 V
NOMINAL AC OUTPUT CURRENT	48 A
NOMINAL BATTERY ENERGY	15 KWH
TOTAL QUANTITY	01

ARRAY DETAILS	
DC SYSTEM SIZE	11.28 KW
AC SYSTEM SIZE	11.5 KW
TOTAL NO. OF MODULES	30
NO. OF MODULE PER STRING	02@12 & 01@06
NO. OF STRING	03

PER FL. STATUE 377.705 (REVISED 7/1/2017) I, KIMANDY LAWRENCE PE#83317, AN ENGINEER LICENSED PURSUANT TO CHAPTER 471, CERTIFY THAT THE PV ELECTRICAL SYSTEM AND ELECTRICAL COMPONENTS ARE DESIGNED AND APPROVED USING THE STANDARDS CONTAINED IN THE MOST RECENT VERSION OF THE FLORIDA BUILDING CODE.

BUILDING DEPARTMENT SEAL STAMP

LORD & LAWRENCE
CONSULTING ENGINEERS

CONTACT: (561) 660-5200
6801 LAKE WORTH ROAD SUITE 302
LAKE WORTH, FL 33467
FLORIDA REGISTRY# 33809

solar impact

CONTACT: (352) 554-7033
4509 NORTHWEST 23RD AVENUE,
GAINESVILLE, FL, 32606
SOLAR CONTRACTOR LICENSE: CVC56761

HALEY, PATRICIA

7115 SOUTHWEST HERLONG
STREET, FORT WHITE, FL, 32038
29.986761, -82.742427

SIGNATURE WITH SEAL

ELECTRICAL LINE DIAGRAM

PV-3

ELECTRICAL CALCULATIONS:

1) CURRENT-CARRYING CONDUCTORS

1A) BEFORE JUNCTION BOX-1

AMBIENT TEMPERATURE = 33°C
 CONDUIT INSTALLED AT MINIMUM DISTANCE OF 7/8 INCHES ABOVE ROOFNEC 310.15(B)(2)
 TEMPERATURE DERATE FACTOR - (0.96)NEC 310.15(B)(1)(1)
 GROUPING FACTOR - (1)NEC 310.15(C)(1)

CONDUCTOR AMPACITY
 = (MODULE ISC) / A.T.F / G.F ...NEC 690.8(A)(1)(E) AND NEC 690.8(B)(2)
 = 18.43 / 0.96 / 1
 = 19.99 ASELECTED CONDUCTOR - #8 THWN-2 ...NEC 310.16

1A) BEFORE JUNCTION BOX-2

AMBIENT TEMPERATURE = 33°
 CONDUIT INSTALLED AT MINIMUM DISTANCE OF 7/8 INCHES ABOVE ROOFNEC 310.15(B)(2)
 TEMPERATURE DERATE FACTOR - (0.96)NEC 310.15(B)(1)(1)
 GROUPING FACTOR - (0.8)NEC 310.15(C)(1)

CONDUCTOR AMPACITY
 = (MODULE ISC) / A.T.F / G.F ...NEC 690.8(A)(1)(E) AND NEC 690.8(B)(2)
 = 9.63 / 0.96 / 0.8
 = 12.54 ASELECTED CONDUCTOR - #8 THWN-2 ...NEC 310.16

1B) AFTER INVERTER

TEMPERATURE DERATE FACTOR - 0.96
 GROUPING FACTOR - 1

CONDUCTOR AMPACITY
 = (TOTAL INV O/P CURRENT) x 1.25 ...NEC 690.8(A)(1)(E) AND NEC 690.8(B)(1)
 = 48 X 1.25
 = 60.00 ASELECTED CONDUCTOR - #6 THWN-2 ...NEC 310.16

2) PV OVERCURRENT PROTECTION

= (TOTAL INV O/P CURRENT) x 1.25NEC 690.9(B)
 = 48 x 1.25
 = 60.00 A
 SELECTED OCPD IS 60A

SELECTED EQUIPMENT GROUNDING CONDUCTOR (EGC) = #10 THWN-2 ...NEC 250.122

GENERAL ELECTRICAL NOTES:

1. THE DC AND AC CONNECTORS OF THE FRANKLIN APOWER S ARE LISTED TO MEET REQUIREMENTS AN EQUIPMENT DISCONNECTING MEANS SHALL BE PERMITTED TO BE REMOTE FROM THE EQUIPMENT WHERE THE EQUIPMENT DISCONNECTING MEANS CAN BE REMOTELY OPERATED FROM WITHIN 3 M (10 FT) OF THE EQUIPMENT BY NEC 690.15(A).
2. MCI BRANCH CIRCUIT CONDUCTORS ARE MANUFACTURED PV WIRE LISTED . THEY ARE ROHS, OIL RESISTANT, AND UV RESISTANT. THEY CONTAIN 10 AWG CONDUCTORS OF TYPE THHN/THWN-2 DRY/WET AND CERTIFIED TO UL3003 AND UL 9703. THE CABLE'S DOUBLE INSULATED RATING REQUIRES NO NEUTRAL OR GROUNDED CONDUCTOR.
3. ALL METAL ENCLOSURES, RACEWAYS, CABLES AND EXPOSED NONCURRENT-CARRYING METAL PARTS OF EQUIPMENT SHALL BE GROUNDED TO EARTH AS REQUIRED BY NEC 250.4(B) AND PART III OF NEC ARTICLE 250 AND EQUIPMENT GROUNDING CONDUCTORS SHALL BE SIZED ACCORDING TO NEC 690.45. THE GROUNDING ELECTRODE SYSTEM SHALL ADHERE TO 690.47(A).
4. PV SYSTEM DISCONNECT SHALL BE READILY ACCESSIBLE.
5. POINT-OF-CONNECTION SHALL BE MADE IN COMPLIANCE WITH NEC 705.11 or 705.12
6. UTILITY HAS 24-HR UNRESTRICTED ACCESS TO ALL PHOTOVOLTAIC SYSTEM COMPONENTS LOCATED AT THE SERVICE ENTRANCE.
7. CONDUCTORS EXPOSED TO SUNLIGHT SHALL BE LISTED AS SUNLIGHT RESISTANT PER NEC ARTICLE 300.6(C)(1) AND ARTICLE 310.10 (D).
8. CONDUCTORS EXPOSED TO WET LOCATIONS SHALL BE SUITABLE FOR USE IN WET LOCATIONS PER NEC ARTICLE 310.10 (C).
9. ALL PHOTOVOLTAIC SYSTEM DC CIRCUITS RAN INSIDE OR ON ALL BUILDINGS AND STRUCTURES SHALL BE ENCLOSED IN METALLIC CONDUIT IN COMPLIANCE WITH NEC 690.31(D). THIS REQUIREMENT SHALL APPLY TO STRING INVERTER-BASED SYSTEMS, BUT SHALL NOT APPLY TO MICROINVERTER-BASED SYSTEMS.
10. A 10 AWG COPPER EQUIPMENT GROUNDING CONDUCTOR SIZED IN ACCORDANCE WITH NEC 690.45 SHALL BE USED TO BOND RAILS AND OTHER ROOFTOP EQUIPMENT. THE CONDUCTOR SHALL BE PROTECTED FROM PHYSICAL DAMAGE IN ACCORDANCE WITH NEC 250.120(C) BY RUNNING WITHIN THE HOLLOW SPACE BENEATH THE SOLAR STRUCTURE OR BY RUNNING WITHIN AN IDENTIFIED RACEWAY OR CABLE ARMOR. IF THE EQUIPMENT GROUNDING CONDUCTOR IS UNPROTECTED FROM PHYSICAL DAMAGE AT ANY POINT IN ITS CONDUCTOR RUN THE CONDUCTOR SHALL BE INCREASED TO A MINIMUM OF 6 AWG COPPER IN ACCORDANCE WITH NEC 250.120(C).

GROUNDING NOTES:

PV MODULE AND RACKING GROUNDING AS PER APPROVED INSTALLATION PRACTICE AND IN LINE WITH MANUFACTURE'S GUIDELINES.

VOLTAGE DROP CALCULATION

MAX VOLTAGE DROP CALCULATION						
CABLE SIZE	CABLE DESCRIPTION	ONE WAY DISTANCE IN FEET (D)	BRANCH CURRENT (I)	RESISTANCE OF CONDUCTOR(R)	VOLTAGE (V)	% VOLTAGE DROP=(0.2*D*I*R)/V
#2/0 THWN-2	METER MAIN COMBO TO AGATE	55	200	0.0967	240	0.88
#10 THWN-2	METER MAIN COMBO TO AGATE	55	28	1.24	240	1.6
#2/0 THWN-2	AGATE TO METER MAIN COMBO	55	200	0.0967	240	0.88

MAX VOLTAGE DROP CALCULATION						
CABLE SIZE	CABLE DESCRIPTION	ONE WAY DISTANCE IN FEET (D)	BRANCH CURRENT (Imp)	RESISTIVITY (K)	CIRCULAR MILS (CM)	% VOLTAGE DROP=(2*K*I*D)/CM
#8 THWN-2	BARN TO AGATE	66	17.44	12.9	16510	1.8
#8 THWN-2	HOUSE TO AGATE	125	9.07	12.9	16510	1.77

BUILDING DEPARTMENT SEAL STAMP



CONTACT: (561) 660-5200
 6801 LAKE WORTH ROAD SUITE 302
 LAKE WORTH, FL 33467
 FLORIDA REGISTRY# 33809



CONTACT: (352) 554-7033
 4509 NORTHWEST 23RD AVENUE,
 GAINESVILLE, FL, 32606
 SOLAR CONTRACTOR LICENSE: CVC56761

HALEY, PATRICIA

7115 SOUTHWEST HERLONG STREET, FORT WHITE, FL, 32038
 29.986761, -82.742427

SIGNATURE WITH SEAL

ELECTRICAL CALCULATIONS

PV-4

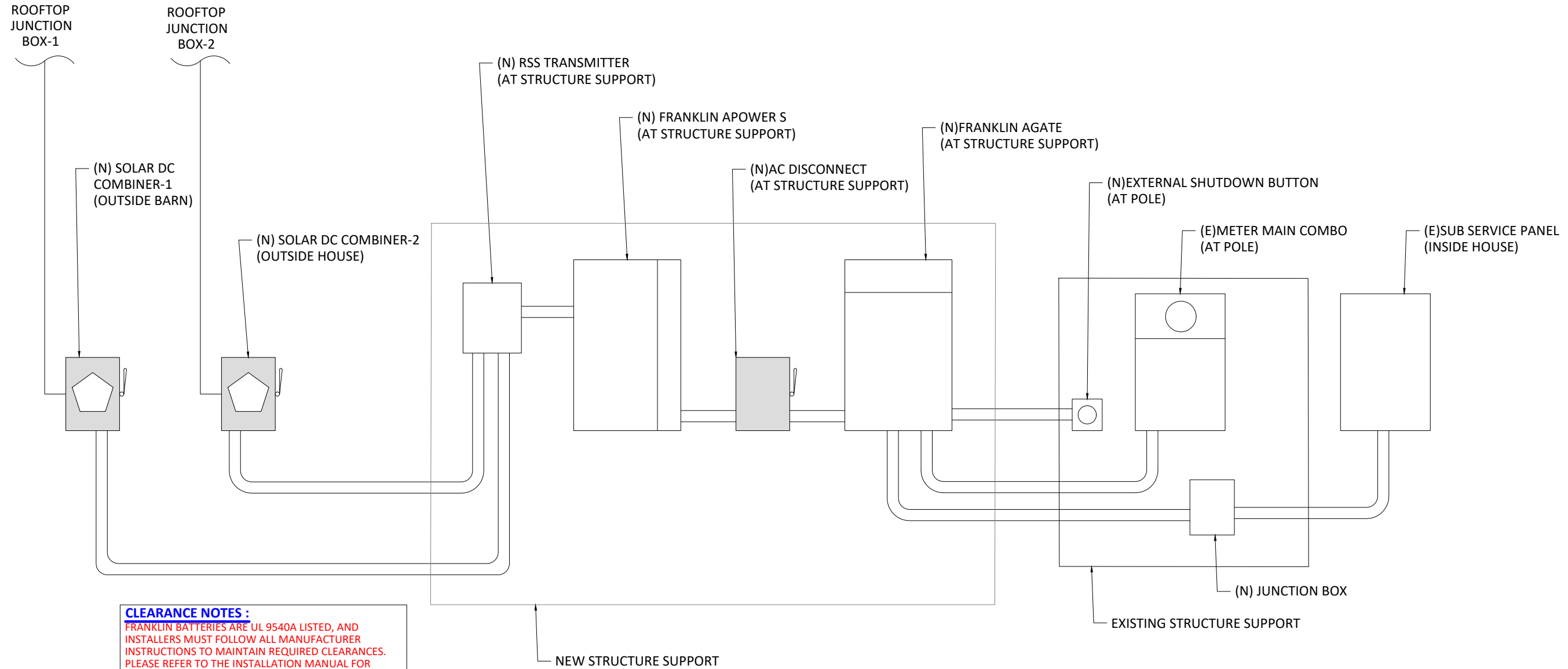

CLEARANCE NOTES :
 FRANKLIN BATTERIES ARE UL 9540A LISTED, AND INSTALLERS MUST FOLLOW ALL MANUFACTURER INSTRUCTIONS TO MAINTAIN REQUIRED CLEARANCES. PLEASE REFER TO THE INSTALLATION MANUAL FOR SPECIFIC DETAILS AND ENSURE A 3-FOOT CLEARANCE IS MAINTAINED IN FRONT OF ALL ELECTRICAL EQUIPMENT.

BUILDING DEPARTMENT SEAL STAMP



CONTACT: (561) 660-5200
 6801 LAKE WORTH ROAD SUITE 302
 LAKE WORTH, FL 33467
 FLORIDA REGISTRY# 33809



CONTACT: (352) 554-7033
 4509 NORTHWEST 23RD AVENUE,
 GAINESVILLE, FL, 32606
 SOLAR CONTRACTOR LICENSE: CVC56761

HALEY, PATRICIA

7115 SOUTHWEST HERLONG
 STREET, FORT WHITE, FL, 32038
 29.986761, -82.742427

SIGNATURE WITH SEAL

ELEVATION VIEW

PV-5

**PHOTOVOLTAIC
DC DISCONNECT**

NEC 690.13(B)
LOCATION(S): DC DISCONNECT

**MAXIMUM DC VOLTAGE
600
OF PV SYSTEM**

NEC 690.13(B)
LOCATION(S): DC DISCONNECT

SOLAR PV DC CIRCUIT

NEC 690.31(D)(2)
LOCATION(S): CONDUIT RACEWAY

! WARNING
THIS EQUIPMENT IS FED BY MULTIPLE SOURCES. TOTAL RATING OF ALL OVERCURRENT DEVICES EXCLUDING MAIN SUPPLY OVERCURRENT DEVICE SHALL NOT EXCEED AMPACITY OF BUSBAR.

NEC 705.12(B)(3)(3)
LOCATION(S): METER MAIN COMBO

**PHOTOVOLTAIC
POWER SOURCE**

NEC 690.31(D)(2)
LOCATION(S): CONDUIT RACEWAYS

**PHOTOVOLTAIC
AC DISCONNECT**

NEC 690.13(B)
LOCATION(S): AC DISCONNECT

! WARNING
DUAL POWER SOURCE
SECOND POWER SOURCE IS PV SYSTEM

NEC 705.12(C), NEC 690.59
LOCATION(S): METER MAIN COMBO

PHOTOVOLTAIC AC DISCONNECT
RATED AC OUTPUT CURRENT 48
NOMINAL OPERATING AC VOLTAGE 240

NEC 690.54
LOCATION(S): INVERTER

**PV SYSTEM
DISCONNECT**

NEC 690.13(B)
LOCATION(S): AC DISCONNECT

! WARNING !
MULTIPLE POWER SOURCE
SOURCES: UTILITY GRID, ESS, PV

NEC 2020 EDITION 705.10
LOCATION: METER MAIN COMBO

**SOLAR PV SYSTEM IS EQUIPPED
WITH RAPID SHUTDOWN**

TURN RAPID SHUTDOWN SWITCH TO THE "OFF" POSITION TO SHUT DOWN PV SYSTEM AND REDUCE SHOCK HAZARD IN ARRAY.

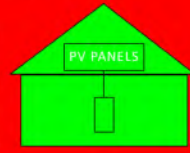

NFPA 1 11.12.2.1.1.1.1
LOCATION(S): AC DISCONNECT

**RAPID SHUTDOWN
SWITCH FOR SOLAR
PV SYSTEM**

NFPA 1 11.12.2.1.1.8
LOCATION(S): RAPID SHUTDOWN SWITCH

EMERGENCY CONTACT
SOLAR IMPACT
(352) 338-8221

UTILITY REQ'D
LOCATION(S): METER MAIN COMBO

**AUXILIARY
GENERATION
DISCONNECT**

UTILITY REQ'D
LOCATION(S): METER MAIN COMBO

WARNING
ELECTRIC SHOCK HAZARD DO NOT TOUCH TERMINALS. TERMINALS ON BOTH THE LINE AND LOAD SIDES MAY BE ENERGISED IN THE OPEN POSITION.

UTILITY REQ'D
LOCATION(S): METER MAIN COMBO, DISCONNECT PANEL, ROOFTOP JUNCTION BOX.

CAUTION: MULTIPLE SOURCES OF POWER

POWER TO THIS SERVICE IS ALSO SUPPLIED FROM THE FOLLOWING SOURCES WITH THE DISCONNECTS LOCATED AS SHOWN

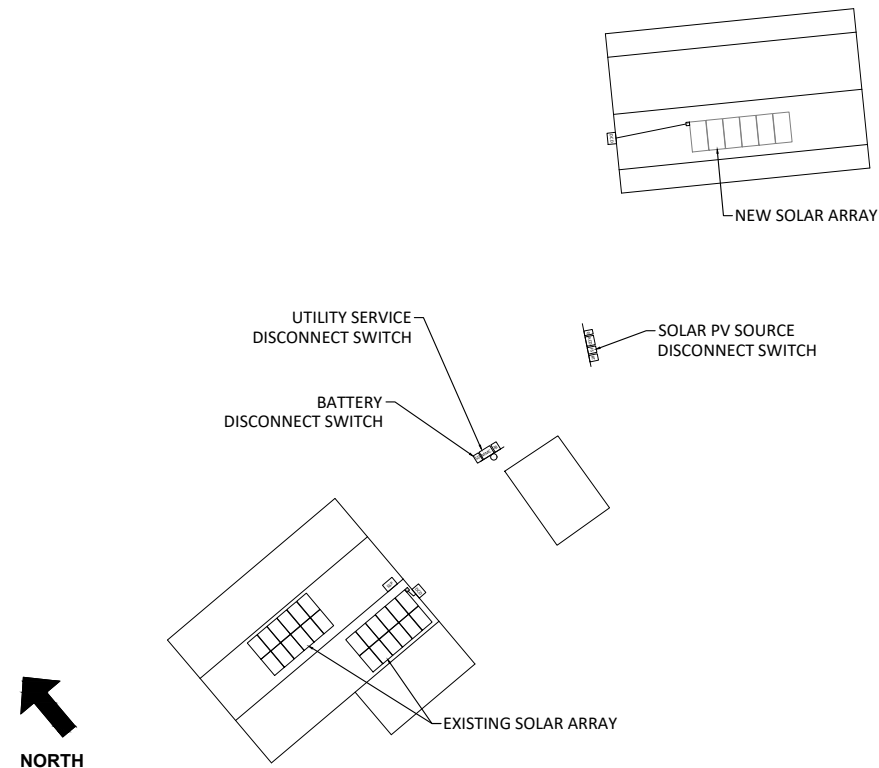

SITE-SPECIFIC DIRECTORY PLACARD(S) SHALL BE INSTALLED AT THE FOLLOWING LOCATION(S): METER MAIN COMBO AND SOLAR PV SOURCE DISCONNECT SWITCH (ACD) NEC 2020 EDITION 705.10

NOTES:
1. THE MATERIAL USED FOR THE PHOTOVOLTAIC SYSTEM LABELS SHALL BE REFLECTIVE, WEATHER RESISTANT, AND CONSTRUCTED OF DURABLE ADHESIVE MATERIAL OR ANOTHER APPROVED MATERIAL SUITABLE FOR THE ENVIRONMENT IN COMPLIANCE WITH NFPA 1-11.12.
2. FONT, TEXT HEIGHT, CAPITALIZATION, FONT COLOR(S), BACKGROUND COLOR(S), DIAGRAM COLOR(S) AND CONTEXT OF PHOTOVOLTAIC SYSTEMS LABELS SHALL COMPLY WITH NFPA 1-11.12 AND NEC 2020 690.56 AS APPLICABLE FOR THE PHOTOVOLTAIC SYSTEM TO BE INSTALLED.

BUILDING DEPARTMENT SEAL STAMP



CONTACT: (561) 660-5200
6801 LAKE WORTH ROAD SUITE 302
LAKE WORTH, FL 33467
FLORIDA REGISTRY# 33809



CONTACT: (352) 554-7033
4509 NORTHWEST 23RD AVENUE,
GAINESVILLE, FL, 32606
SOLAR CONTRACTOR LICENSE: CVC56761

HALEY, PATRICIA

7115 SOUTHWEST HERLONG
STREET, FORT WHITE, FL, 32038
29.986761, -82.742427

SIGNATURE WITH SEAL

LABELS

PV-6

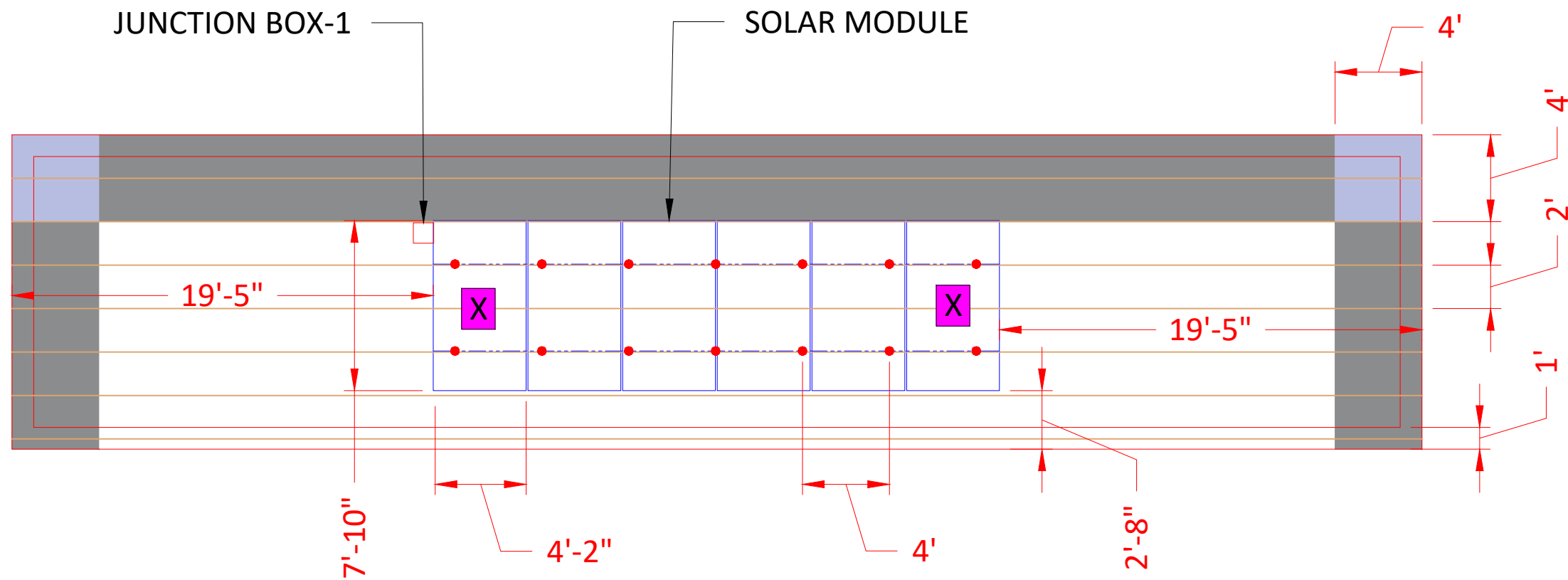

WIND LOAD INFORMATION:
 THIS SYSTEM HAS BEEN DESIGN TO MEET THE REQUIREMENTS OF THE 8TH EDITION OF THE FLORIDA BUILDING CODE AND USED THE FOLLOWING DESIGN PARAMETERS:
 ULTIMATE WIND SPEED: 120 MPH
 EXPOSURE CATEGORY: C
 RISK CATEGORY: II
 MEAN ROOF HEIGHT: 15 FT
 ROOF SLOPE: 07°-20°

- LEGENDS**
- WIND ZONE 1
 - WIND ZONE 1'
 - WIND ZONE (2)
 - WIND ZONE (3)

EQUIPMENT SPECIFICATIONS		
EQUIPMENT	DESCRIPTION	QUANTITY
(N) MODULE	ZXM8-GPLDD132-720W ZNSHINE SOLAR MODULE	06
(E) MODULE	Q.PEAK BLK-G4.1 290W Q.CELL SOLAR MODULE	24
INVERTER	FRANKLIN APOWER S	1
JUNCTION BOX	(8"X8"X3")GENERIC, NEMA 3R	2
NO. OF RSS	TIGO TS4-A-F	30
AC DISCONNECT	PV AC DISCONNECT 240V, 60 AMP, NON-FUSED, NEMA 3R, UL LISTED	1
ATTACHMENT	S-51 SOLARFOOT	14
RACKING SYSTEM	IRONRIDGE (XR100) RAILS	-

SYSTEM INFORMATION	
DC SYSTEM SIZE	11.28 KW
AC SYSTEM SIZE	11.5 KW

ROOF SPECIFICATIONS	
ROOF MATERIAL	TRAPEZOIDAL ROOF
ROOF CONDITION	GOOD

EXISTING ROOF INFORMATION			
ROOF	QUANTITY	SLOPE	AZIMUTH
ROOF 1	06	14°(3/12)	175°

NOTES:

- LOCATION OF JUNCTION BOX(ES), AC DISCONNECTS(S), AC COMBINER PANEL(S), AND OTHER ELECTRICAL EQUIPMENT(S) RELEVANT TO PV INSTALLATION SUBJECT TO CHANGE BASED ON SITE CONDITIONS.
- TRUSS LOCATIONS ARE APPROXIMATE. ACTUAL LOCATIONS MAY DIFFER AND CONTRACTOR MAY NEED TO ADJUST MOUNT LOCATIONS. IN NO CASE SHALL THE MOUNT SPACING EXCEED "MAX. MOUNT SPACING"

- LEGENDS**
- PV ROOF ATTACHMENT
 - RAILS
 - PERLINS
 - ROOF OBSTRUCTION
 - JUNCTION BOX
 - FIRE SETBACK
 - EXPOSED MODULE
 - EDGE MODULES

BUILDING DEPARTMENT SEAL STAMP

LORD & LAWRENCE
 CONSULTING ENGINEERS

CONTACT: (561) 660-5200
 6801 LAKE WORTH ROAD SUITE 302
 LAKE WORTH, FL 33467
 FLORIDA REGISTRY# 33809

solar impact

CONTACT: (352) 554-7033
 4509 NORTHWEST 23RD AVENUE,
 GAINESVILLE, FL, 32606
 SOLAR CONTRACTOR LICENSE: CVC56761

HALEY, PATRICIA

7115 SOUTHWEST HERLONG STREET, FORT WHITE, FL, 32038
 29.986761, -82.742427

SIGNATURE WITH SEAL

RACKING LAYOUT

PV-7

NOTE:
1. H2 IS EQUAL OR LESS THAN 6 INCHES.

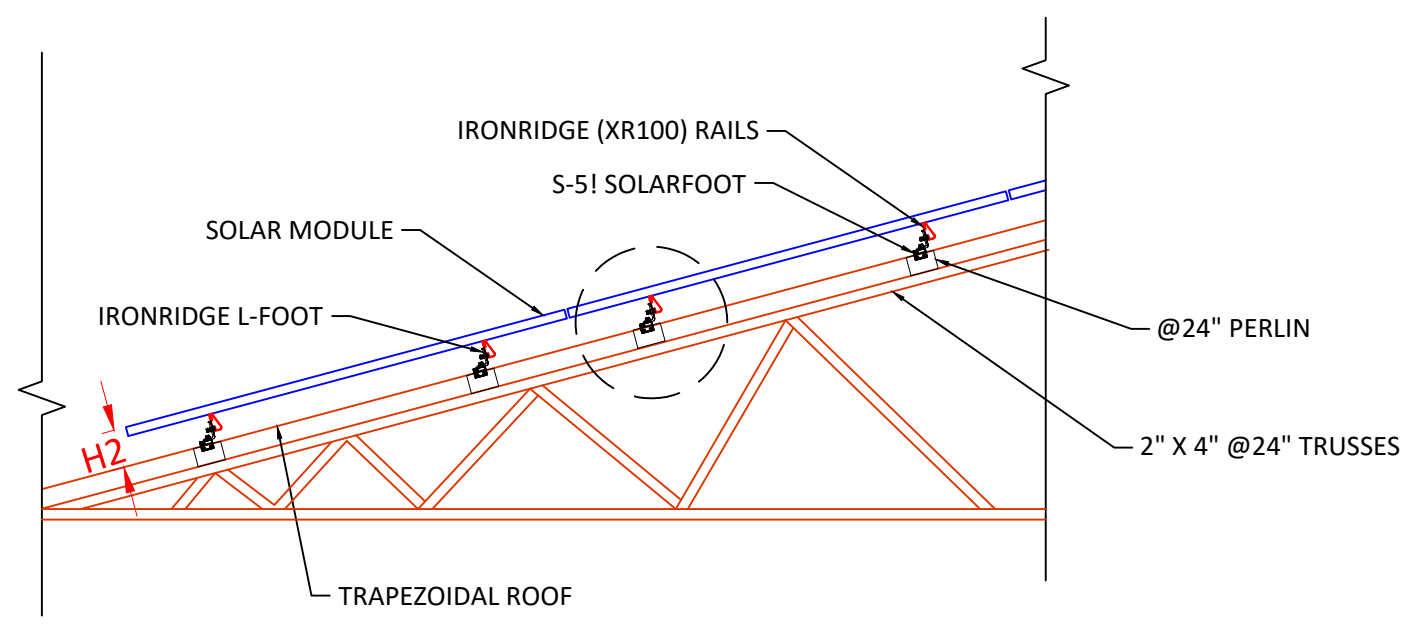

I CERTIFY THAT THE EXISTING ROOF AND BUILDING STRUCTURE CAN WITHSTAND ALL DEAD LOADS IMPOSED BY THE PHOTOVOLTAIC SYSTEM AND ALL WIND LOADS OF SPECIFIED INTENSITY IN ACCORDANCE WITH THE FLORIDA BUILDING CODE.

BUILDING DEPARTMENT SEAL STAMP

 **LORD & LAWRENCE**
CONSULTING ENGINEERS
CONTACT: (561) 660-5200
6801 LAKE WORTH ROAD SUITE 302
LAKE WORTH, FL 33467
FLORIDA REGISTRY# 33809

 **solar impact**
CONTACT: (352) 554-7033
4509 NORTHWEST 23RD AVENUE,
GAINESVILLE, FL, 32606
SOLAR CONTRACTOR LICENSE: CVC56761

HALEY, PATRICIA

7115 SOUTHWEST HERLONG
STREET, FORT WHITE, FL, 32038
29.986761, -82.742427

SIGNATURE WITH SEAL

STRUCTURAL DETAILS

PV-8

WIND LOAD CALCULATIONS FOR MODULES INSTALLED ON ROOFS WITH A HEIGHT LESS THAN 60'

BASED ON ASCE 7-22

SITE INFORMATION

BUILDING CODE VERSION	2023 FLORIDA BUILDING CODE	RISK CATEGORY	II	
MEAN ROOF HEIGHT (ft)	15	EXPOSURE CATEGORY	C	PITCH
LEAST HORIZONTAL DIMENSION (ft)	65	ROOF SLOPE (°)	14.0	3 / 12
PARAPET HEIGHT (ft)	0	ROOF TYPE	GABLE	
MODULE	ZXM8-GPLDD132	ULTIMATE WIND SPEED	120 mph	
MODULE LENGTH (in)	93.86	NOMINAL WIND SPEED	93 mph	
MODULE WIDTH (in)	51.30	K_D	0.85	
MODULE DEPTH (mm)	33	K_{ZF}	1.00	
MODULE DEPTH (in)	1.30	K_z	0.85	
MODULE VERTICAL AREA = A_v (ft ²)	33.44	K_e	1.00	
MODULE HORIZONTAL AREA = A_r (ft ²)	0.85	V_e	1.0 OR 1.5	
HIGH VELOCITY HURRICANE ZONE?	NO	V_a	0.62	
RACKING SYSTEM	IRONRIDGE: XR100	BUILDING TYPE	RESIDENTIAL THREE STORIES OR LESS	
MIN. MODULE SPACING (in)	0.37			

DESIGN CALCULATIONS PER ASCE 7-22 SECTION 29.4.4

VELOCITY PRESSURE (q_h) = $.00256 * K_z * K_{ZF} * K_D * V^2$		VELOCITY PRESSURE (ASD) = 16.0 psf	
WIDTH OF PRESSURE COEFFICIENT	65' * 10% = 6.5'	ZONE WIDTH 'a'	4FT
	15' * 40% = 6'	a = 4ft per FBC R301.2(7)	
EXTERNAL PRESSURE COEFFICIENT			
	Zone 1	0.48	-1.47
	Zone 2	0.48	-2.02
	Zone 3	0.48	-2.66

MODULE DESIGN PRESSURES

	EDGE OR EXPOSED MODULES?	DOWN	UP NORMAL	UP EXPOSED	
Zone 1	YES	16.0	-16.0	-24.0	(psf)
Zone 2	YES	16.0	-19.9	-29.8	(psf)
Zone 3	NO	16.0	-26.2	-26.2	(psf)
MODULE ALLOWABLE PRESSURE		33.3 psf			

RAILS

RAIL ORIENTATION	PORTRAIT
PV SYSTEM TOTAL WEIGHT	572.08 (lb)
PV SYSTEM DISTRIBUTED WEIGHT	2.9 (psf)
SEE RAIL MANUFACTURER TABLES FOR MAXIMUM RAIL SPANS. IN NO CASE SHALL THE ATTACHMENT SPACING SHOWN ABOVE EXCEED THE MAX RAIL SPAN.	

ATTACHMENTS

ATTACHMENT TYPE	S-5! SOLARFOOT				
ROOF DECK	OSB PLYWOOD				
	NORM. MODULES	# RAILS NORM.	EXP. MODULES	# RAILS EXP.	CLAMP UPLIFT
MAX DISTANCE BETWEEN ATTACHMENTS ZONE 1 (in)	48	2-RAIL SYSTEM	48	2-RAIL SYSTEM	NORM. 267.5
MAX UPLIFT FORCE PER ATTACHMENT IN ZONE 1 (lb)	250.3		375.4		EXP. 401.3
MAX DISTANCE BETWEEN ATTACHMENTS ZONE 2 (in)	48	2-RAIL SYSTEM	40	2-RAIL SYSTEM	NORM. 332.3
MAX UPLIFT FORCE PER ATTACHMENT IN ZONE 2 (lb)	310.9		388.6		EXP. 498.4
MAX DISTANCE BETWEEN ATTACHMENTS ZONE 3 (in)	46	2-RAIL SYSTEM	46	2-RAIL SYSTEM	NORM. 438.0
MAX UPLIFT FORCE PER ATTACHMENT IN ZONE 3 (lb)	392.8		392.8		EXP. 438.0
ALLOWABLE UPLIFT FORCE PER ATTACHMENT	400.0	(lb)			
SCREW WITHDRAWAL RESISTANCE	190	(lb)			
MAX LATERAL FORCE PER ATTACHMENT	26	(lb)			
ALLOWABLE LATERAL FORCE PER ATTACHMENT	100	(lb)			
ALLOWABLE UPLIFT PER MID/END CLAMP	945	(lb)			

NOTES

1. MODULE ALLOWABLE WIND PRESSURE OBTAINED FROM MANUFACTURER DATASHEET.
2. SEE ATTACHMENT PLAN FOR ACTUAL ATTACHMENT SPACING IN EACH ZONE
3. HVHZ DEFINED AS MIAMI-DADE AND BROWARD COUNTIES
4. WOOD SCREW WITHDRAWAL RESISTANCE OBTAINED FROM: FASTENER LOADS FOR PLYWOOD, APA - THE WOOD ENGINEERING ASSOCIATION, TECHNICAL NOTE # E803E, JUNE 2011
5. CONTRACTOR SHALL VERIFY THAT ROOF DECKING IS INSTALLED IN ACCORDANCE WITH FBC 7TH EDITION
6. USE FOUR #14 X 1-1/2" WOOD SCREWS TO SECURE MOUNT TO PLYWOOD DECK. SCREWS MUST BE FULLY THREADED AND MUST COMPLETELY PENETRATE THROUGH PLYWOOD DECK
7. RAIL SPANS OBTAINED FROM MANUFACTURER'S PUBLISHED DATA.
8. ANY EDGE AND/OR EXPOSED MODULES PRESENT IN PROPOSED INSTALLATION WHERE ANY WIND ZONE'S DESIGN PRESSURE EXCEEDS THE MODULE ALLOWABLE PRESSURE SHALL BE VERIFIED WITH WEIGHTED AVERAGE PRESSURE CALCULATIONS RESPECTIVE TO EACH MODULE CASE, AS APPLICABLE.

BUILDING DEPARTMENT SEAL STAMP



CONTACT: (561) 660-5200
6801 LAKE WORTH ROAD SUITE 302
LAKE WORTH, FL 33467
FLORIDA REGISTRY# 33809



CONTACT: (352) 554-7033
4509 NORTHWEST 23RD AVENUE,
GAINESVILLE, FL, 32606
SOLAR CONTRACTOR LICENSE: CVC56761

HALEY, PATRICIA

7115 SOUTHWEST HERLONG
STREET, FORT WHITE, FL, 32038
29.986761, -82.742427

SIGNATURE WITH SEAL

WIND LOAD CALCULATION

PV-9

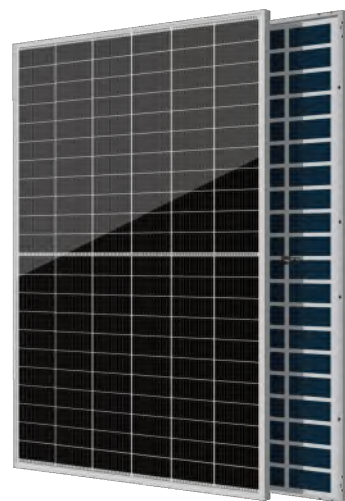

ZXM8-GPLDD132 Series

SMBB HALF-CELL N-Type Bifacial Double Glass
Monocrystalline PV Module

695-730W **23.50%** **0.40%**
POWER RANGE MAXIMUM EFFICIENCY YEARLY DEGRADATION

12 12 YEARS PRODUCT WARRANTY **30** 30 YEARS OUTPUT GUARANTEE



IEC 61215/IEC 61730/IEC 61701/IEC 62716
ISO 14001: Environmental Management System
ISO 9001: Quality Management System
ISO45001: Occupational Health and Safety Management System

*As there are different certification requirements in different markets, please contact your local zshine sales representative for the specific certificates applicable to the products in the region in which the products are to be used.

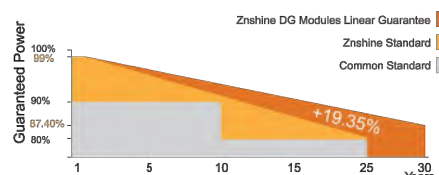

*Please check Limited Warranty for Standard PV Modules which is officially released by ZNSHINE PV-TECH Co., Ltd

KEY FEATURES

- Excellent Cells Efficiency**
SMBB technology reduce the distance between busbars and finger grid line which is benefit to power increase.
- Anti PID**
Ensured PID resistance through the quality control of cell manufacturing process and raw materials.
- TIER 1**
Global, Tier 1 bankable brand, with independently certified advanced automated manufacturing.
- Bifacial Technology**
Up to 25% additional power gain from back side depending on albedo.

- Better Weak Illumination Response**
More power output in weak light condition, such as haze, cloudy, and early morning.
- Adapt To Harsh Outdoor Environment**
Resistant to harsh environments such as salt, ammonia, sand, high temperature and high humidity environment.
- Excellent Quality Management System**
Warranted reliability and stringent quality assurances well beyond certified requirements.

Founded in 2006, ZNSHINE solar is a world's leading high-tech PV module manufacturer. With the advanced production lines, the company boasts module capacity of 10 GW. Bloomberg has listed ZNSHINE as a global Tier 1 PV module maker. Today Zshine has distributed its sales to more than 60 countries around the globe.
www.znshinesolar.com

ZXM8-GPLDD132 Series | SMBB HALF-CELL N-Type Bifacial Double Glass Monocrystalline PV Module



DIMENSIONS OF PV MODULE(mm)

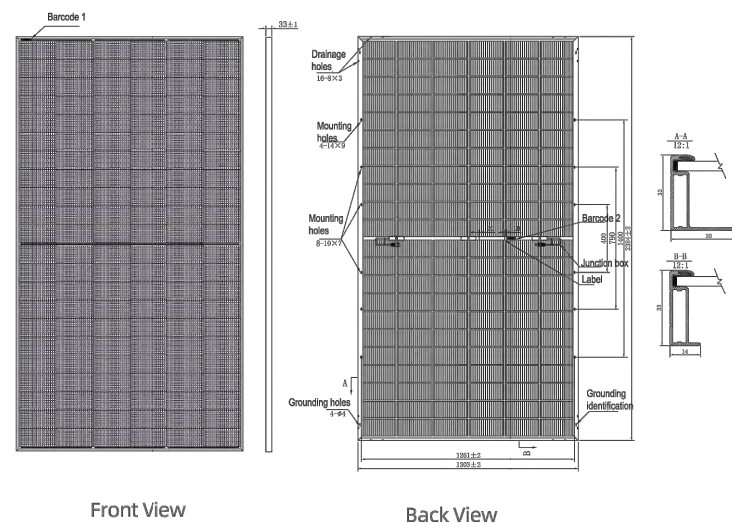

*Remark: customized frame color and cable length available upon request

I-V CURVES OF PV MODULE(710W)

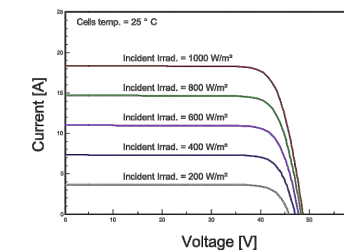

P-V CURVES OF PV MODULE(710W)

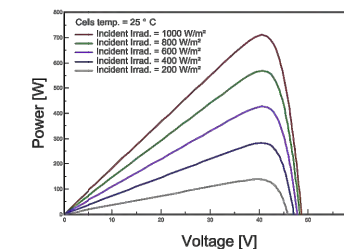

ELECTRICAL CHARACTERISTICS | STC*

Nominal Power Watt Pmax(W)*	695	700	705	710	715	720	725	730
Maximum Power Voltage Vmp(V)	40.30	40.50	40.70	40.90	41.10	41.30	41.50	41.70
Maximum Power Current Imp(A)	17.25	17.29	17.33	17.37	17.40	17.44	17.47	17.51
Open Circuit Voltage Voc(V)	48.10	48.30	48.50	48.70	48.90	49.10	49.30	49.50
Short Circuit Current Isc(A)	18.23	18.27	18.31	18.35	18.39	18.43	18.47	18.51
Module Efficiency (%)	22.37	22.53	22.70	22.86	23.02	23.18	23.34	23.50

*The data above is for reference only and the actual data is in accordance with the practical testing
*STC (Standard Test Condition): Irradiance 1000W/m², Module Temperature 25±2°C, AM 1.5
*Measuring uncertainty: ±3%, all the electrical characteristics such as Power, Im, Vm, Isc, Voc and FF are within ±5% tolerance.

ELECTRICAL CHARACTERISTICS | NMOT*

Maximum Power Pmax(Wp)	527.80	531.50	533.50	537.30	542.60	546.40	550.00	553.80
Maximum Power Voltage Vmpp(V)	37.80	38.00	38.00	38.20	38.50	38.70	38.80	39.00
Maximum Power Current Imp(A)	13.97	14.00	14.04	14.07	14.10	14.13	14.16	14.19
Open Circuit Voltage Voc(V)	45.50	45.70	45.80	45.90	46.30	46.40	46.60	46.80
Short Circuit Current Isc(A)	14.70	14.74	14.78	14.81	14.83	14.87	14.90	14.93

*NMOT: Irradiance 800W/m², Ambient Temperature 20°C, AM 1.5, Wind Speed 1m/s

ELECTRICAL CHARACTERISTICS (REAR POWER GAIN) *

Maximum Power: Pmax(W)	730	735	740	746	751	756	761	767
Module Efficiency (%)	23.49	23.66	23.83	24.00	24.17	24.34	24.51	24.68
Maximum Power: Pmax(W)	799	805	811	817	822	828	834	840
Module Efficiency (%)	25.73	25.91	26.10	26.28	26.47	26.66	26.84	27.03
Maximum Power: Pmax(W)	869	875	881	888	894	900	906	913
Module Efficiency (%)	27.97	28.17	28.37	28.57	28.77	28.97	29.17	29.38

*Bifacial Gain: The additional gain from the back side compared to the power of the front side at the standard test condition. It depends on mounting (structure, height, tilt angle etc.) and albedo of the ground.

MECHANICAL DATA

Solar cells	N-type Monocrystalline
Cells orientation	132 (6x22)
Module dimension	2384x1303x33 mm (With Frame)
Weight	38.5±1.0 kg
Glass	2.0 mm+2.0mm, High Transmission, AR Coated Heat Strengthened Glass
Junction box	IP 68, 3 diodes
Cables	4 mm², 350 mm (With Connectors)
Connectors*	MC4-compatible

*Please refer to regional datasheet for specified connector

TEMPERATURE RATINGS

NMOT	43°C ±2°C	Maximum system voltage	1500 V DC
Temperature coefficient of Pmax	-0.30±0.03%/°C	Operating temperature	-40°C~+85°C
Temperature coefficient of Voc	-0.25%/°C	Maximum series fuse	35 A
Temperature coefficient of Isc	0.046%/°C	Front Side Maximum Static Loading	Up to 5400Pa
Refer. Bifacial Factor	(80±10)%	Rear Side Maximum Static Loading	Up to 2400Pa

*Remark: Do not connect Fuse in Combiner Box with two or more strings in parallel connection

PACKAGING CONFIGURATION *

Piece/Box	33
Piece/Container(40'HQ)	594

*Customized packaging is available upon request.
*Remark: Electrical data in this catalog do not refer to a single module and they are not part of the offer.
*They only serve for comparison among different module types.
*Caution: Please be kindly advised that PV modules should be handled and installed by qualified people who have professional skills and please carefully read the safety and installation instructions before using our PV modules.

Add : No. 229 Tongda Avenue Suqian Economic and Technological Development Zone 223800 Suqian City, Jiangsu P.R. China Tel: +86 519 6822 0233 E-mail: info@znshinesolar.com

Note: Specifications included in this datasheet are subject to change without notice. ZNSHINE reserves the right of final interpretation © ZNSHINE SOLAR 2025 | Version: ZXM8-GPLDD132 2502.E
No special undertaking or warranty for the suitability of special purpose or being installed in extraordinary surroundings is granted unless as otherwise specifically committed by manufacturer in contract document

BUILDING DEPARTMENT SEAL STAMP



CONTACT: (561) 660-5200
6801 LAKE WORTH ROAD SUITE 302
LAKE WORTH, FL 33467
FLORIDA REGISTRY# 33809



CONTACT: (352) 554-7033
4509 NORTHWEST 23RD AVENUE,
GAINESVILLE, FL, 32606
SOLAR CONTRACTOR LICENSE: CVC56761

HALEY, PATRICIA

7115 SOUTHWEST HERLONG
STREET, FORT WHITE, FL, 32038
29.986761, -82.742427

SIGNATURE WITH SEAL

MODULE DATASHEET

PV-10

powered by
Q.ANTUM



Q.PEAK BLK-G4.1

290-305

ENDURING HIGH PERFORMANCE



- Q.ANTUM TECHNOLOGY: LOW LEVELISED COST OF ELECTRICITY**
Higher yield per surface area, lower BOS costs, higher power classes, and an efficiency rate of up to 18.6%.
- INNOVATIVE ALL-WEATHER TECHNOLOGY**
Optimal yields, whatever the weather with excellent low-light and temperature behaviour.
- ENDURING HIGH PERFORMANCE**
Long-term yield security with Anti LID Technology, Anti PID Technology¹, Hot-Spot Protect and Traceable Quality Tra.Q™.
- EXTREME WEATHER RATING**
High-tech aluminium alloy frame, certified for high snow (5400Pa) and wind loads (4000Pa).
- MAXIMUM COST REDUCTIONS**
Up to 10% lower logistics costs due to higher module capacity per box.
- A RELIABLE INVESTMENT**
Inclusive 12-year product warranty and 25-year linear performance warranty².

¹ APT test conditions according to IEC/TS 62804-1:2015, method B (-1500V, 168h)
² See data sheet on rear for further information.

THE IDEAL SOLUTION FOR:
Rooftop arrays on residential buildings

Engineered in Germany



MECHANICAL SPECIFICATION

Format	65.7 in × 39.4 in × 1.26 in (including frame) (1670 mm × 1000 mm × 32 mm)
Weight	40.8 lbs (18.5 kg)
Front Cover	0.13 in (3.2 mm) thermally pre-stressed glass with anti-reflection technology
Back Cover	Composite film
Frame	Black anodized aluminum
Cell	6 × 10 monocrystalline Q.ANTUM solar cells
Junction Box	3.35-4.53 in × 2.36-3.15 in × 0.59-0.75 in (85-115 mm × 60-80 mm × 15-20 mm), IP67, with bypass diodes
Cable	4 mm ² Solar cable; (+) ≥ 39.37 in (1000 mm), (-) ≥ 39.37 in (1000 mm)
Connector	Stäubli MC4, Hanwha Q CELLS HQC4, Tonglin TL-Cable01S, Amphenol UTX; IP68

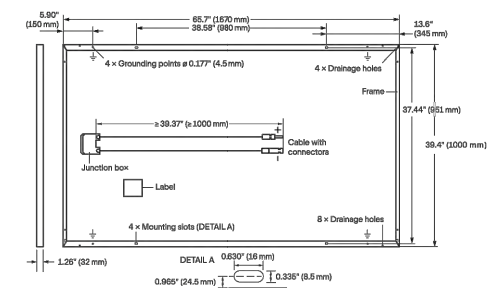

ELECTRICAL CHARACTERISTICS

POWER CLASS		290	295	300	305
MINIMUM PERFORMANCE AT STANDARD TEST CONDITIONS, STC¹ (POWER TOLERANCE +5 W / -0 W)					
Power at MPP ²	P _{MPP} [W]	290	295	300	305
Short Circuit Current ²	I _{SC} [A]	9.63	9.70	9.77	9.84
Open Circuit Voltage ²	V _{OC} [V]	39.19	39.48	39.76	40.05
Current at MPP	I _{MPP} [A]	9.07	9.17	9.26	9.35
Voltage at MPP	V _{MPP} [V]	31.96	32.19	32.41	32.62
Efficiency ²	η [%]	≥17.4	≥17.7	≥18.0	≥18.3
MINIMUM PERFORMANCE AT NORMAL OPERATING CONDITIONS, NMOT²					
Power at MPP	P _{MPP} [W]	216.8	220.6	224.3	228.0
Short Circuit Current	I _{SC} [A]	7.76	7.82	7.87	7.93
Open Circuit Voltage	V _{OC} [V]	36.94	37.21	37.48	37.76
Current at MPP	I _{MPP} [A]	7.12	7.20	7.28	7.35
Voltage at MPP	V _{MPP} [V]	30.45	30.64	30.82	31.00

¹ Measurement tolerances P_{MPP} ± 3%; I_{SC}; V_{OC} ± 5% at STC: 1000 W/m², 25 ± 2 °C, AM 1.5 G according to IEC 60904-3 • ² 800 W/m², NMOT, spectrum AM 1.5 G

Q CELLS PERFORMANCE WARRANTY

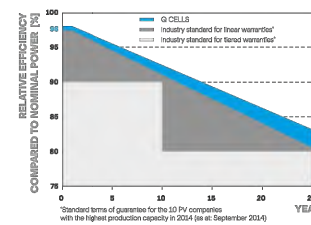

At least 98% of nominal power during first year. Thereafter max. 0.6% degradation per year. At least 92.6% of nominal power up to 10 years. At least 83.6% of nominal power up to 25 years.

All data within measurement tolerances. Full warranties in accordance with the warranty terms of the Q CELLS sales organisation of your respective country.

PERFORMANCE AT LOW IRRADIANCE

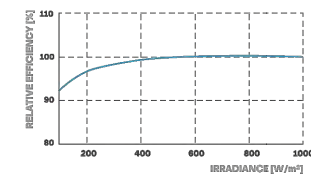

Typical module performance under low irradiance conditions in comparison to STC conditions (25 °C, 1000 W/m²)

TEMPERATURE COEFFICIENTS

Temperature Coefficient of I _{SC}	α [%/K]	+0.04	Temperature Coefficient of V _{OC}	β [%/K]	-0.27
Temperature Coefficient of P _{MPP}	γ [%/K]	-0.38	Normal Module Operating Temperature	NMOT [°F]	109 ± 5.4 (43 ± 3 °C)

PROPERTIES FOR SYSTEM DESIGN

Maximum System Voltage V _{sys}	[V]	1000 (IEC) / 1000 (UL)	Safety Class	II
Maximum Series Fuse Rating	[A DC]	20	Fire Rating	C / TYPE 2
Max. Design Load, Push / Pull ³	[lbs / ft ²]	75 (3600 Pa) / 55 (2667 Pa)	Permitted Module Temperature on Continuous Duty	-40 °F up to +185 °F (-40 °C up to +85 °C)
Max. Test Load, Push / Pull ³	[lbs / ft ²]	113 (6400 Pa) / 84 (4000 Pa)		

³ See Installation Manual

QUALIFICATIONS AND CERTIFICATES

VDE Quality Tested, UL 1703, CE-compliant, IEC 61215:2016, IEC 61730:2016, Application Class II, U.S. Patent No. 9,893,215 (solar cells)



PACKAGING INFORMATION

Number of Modules per Pallet	32
Number of Pallets per 53' Container	30
Number of Pallets per 40' Container	26
Pallet Dimensions (L × W × H)	68.7 × 45.3 × 46.1 in (1725 × 1150 × 1170 mm)
Pallet Weight	1435 lbs (651 kg)

Note: Installation instructions must be followed. See the installation and operating manual or contact our technical service department for further information on approved installation and use of this product.

Hanwha Q CELLS America Inc.
400 Spectrum Center Drive, Suite 1400, Irvine, CA 92618, USA | TEL +1 949 748-5996 | EMAIL inquiry@us.q-cells.com | WEB www.q-cells.com/na

Specifications subject to technical changes © Q CELLS Q.PEAK-BLK-G4.1_290-305_2019-03_Rev02_NA

BUILDING DEPARTMENT SEAL STAMP



CONTACT: (561) 660-5200
6801 LAKE WORTH ROAD SUITE 302
LAKE WORTH, FL 33467
FLORIDA REGISTRY# 33809



CONTACT: (352) 554-7033
4509 NORTHWEST 23RD AVENUE,
GAINESVILLE, FL, 32606
SOLAR CONTRACTOR LICENSE: CVC56761

HALEY, PATRICIA

7115 SOUTHWEST HERLONG
STREET, FORT WHITE, FL, 32038
29.986761, -82.742427

SIGNATURE WITH SEAL

MODULE DATASHEET

PV-10.1

FRANKLINWH

aPower S

Complete solar and battery system

The aPower S is a battery storage device with integrated inverters to support a direct connection to solar (PV) panels. The front wiring design makes installation easier and more efficient.

The aPower S also supports parallel AC-coupled connection with FranklinWH aPower 2 batteries to expand power and capacity for homes at the same time. It can be flexibly deployed according to customer requirements. Excellent load adaptability provides the best backup experience to users.

aPower S has a 15 kWh capacity, which can provide whole home backup with a single battery. It provides a 60 MWh throughput or 15-year warranty, helping users to easily achieve reliable energy independence and freedom over the long term.



- ✓ Four built-in MPPTs
- ✓ 15 A per MPPT
- ✓ RTE 90.5%
- ✓ Safer LFP battery cell chemistry
- ✓ Built-in hybrid inverter
- ✓ 15 kWh per unit, up to 225 kWh (15 units) per aGate
- ✓ Max 11.5 kW continuous / 15 kW peak for 10 seconds
- ✓ Built-in heating blanket ensures reliable cold-weather performance
- ✓ Stable operations in extreme 131° F (55° C)
- ✓ IP67 weather protection

PERFORMANCE SPECIFICATIONS

Name	aPower S	Noise Emission	30 dBA Typical 45 dBA Maximum
SKU	APRS-10K15V1-US	Flood Resistance (IP67)	Up to 29" from the aPower S base
Nameplate Model	aPower S-10	AC Metering	Revenue Grade (+/- 0.5%, ANSI C12.20)
Certification / CEC Listing Name	aPower Syyy	Safety Protections	Integrated arc fault circuit interrupter(AFCI), Isolation Monitor Interrupter
Battery Chemistry	Lithium Iron Phosphate (LFP)	User Interface	FranklinWH App
Usable System Energy	15 kWh ¹ per unit, up to 15 units per aGate	Warranty ²	15 years or 60 MWh throughput
Aggregate Warrantied Throughput	60 MWh	Solar Technical Specifications	
Max Real Power (Charge)	8 kW continuous ³	Maximum Solar STC Input	20 kW
Max Real Power (Discharge)		Withstand Voltage	600 Vdc
- With PV Input	11.5 kW continuous ³	PV DC Input Voltage Range	60 - 600 Vdc
- Battery Only	10 kW continuous ³	PV DC MPPT Voltage Range	90 - 480 Vdc
Nominal AC Voltage	120 / 240 V, 120 / 208 V, 60 Hz	MPPTs	4
Coupling	Hybrid-Coupled	Maximum Current per MPPT (Imp)	15 A ⁴
Phase	2 W+N+PE	Maximum Short Circuit Current per MPPT (Isc)	20 A
Round Trip Efficiency (Solar - Battery - Load)	90.5% ⁵	Maximum Power per MPPT	5 kW
Solar to Home / Grid - CEC Efficiency	97.5% ⁵	Maximum Continuous Total MPPT Output	15 kW
Maximum Short-Circuit Current Rating	10 kA		
Work Modes	Self-Consumption Time of Use Emergency Backup		

WWW.FRANKLINWH.COM

DATASHEET

PERFORMANCE SPECIFICATIONS

Power Rated

Nominal Output Power (AC)	5 kW	7.6 kW	9.6 kW	10 kW	11.5 kW
Maximum Apparent Power	5 kVA	7.6 kVA	9.6 kVA	11.5 kVA	11.5 kVA
Maximum Continuous Current	21 A	32 A	40 A	48 A	48 A
Overcurrent Protection Device	30 A	40 A	50 A	60 A	60 A
Maximum Continuous Input Power	5 kW	7.6 kW	8 kW	8 kW	8 kW
Power Factor	±1	±1	±1	±0.87	±1

Off-Grid Specifications⁶

THDU	< 1%
Voltage Regulation Accuracy	±1%
Frequency Accuracy	±0.1 Hz
Max Half-Wave Load Capability	5 kW ¹
Max Peak Output Power	15 kW @ 10 S ²
Max Transient load capacity	25 kW @ 1 S ²
Load Imbalance Ratio	100%
Load Start Capability	185 A LRA ³

COMPLIANCE INFORMATION

Certifications	UL9540; UL9540A; UL1973; UL1741; UL1741 SB; UL1741 PCS; UL 1741 Multimode; UL 1741 CRD; UL 3141; UL1699B; UL1998; UN38.3; IEEC 1547; IEEE 1547.1; CSA 22.2 No.107.1;
Seismic	AC 156, OSHPD, IEEE 693-2005 (high)
Environmental	California Proposition 65
Emissions	FCC Part 15 Class B, ICES 003

ENVIRONMENTAL SPECIFICATIONS

Enclosure Type	Type 3R
Ingress Protection	IP55 (Wiring) IP67 (Battery Pack & Inverter)
Operating Temperature	-4 °F to 122 °F (-20 °C to 50 °C) Operates up to 131 °F (55 °C) derated output
Operating Humidity (RH)	Up to 100% RH, condensing
Altitude	Maximum 9,843 ft (3,000 m)
Environment	Indoor / Outdoor

MECHANICAL SPECIFICATIONS

Dimensions (H x W x D)	45.2 in x 29.5 in x 11.8 in (1149 mm x 750 mm x 300 mm)
Weight, aPower S complete	388 lbs (176 kg)
Weight, without Cover	365 lbs (166 kg)
Mounting	Wall or floor mount
Cooling	Natural

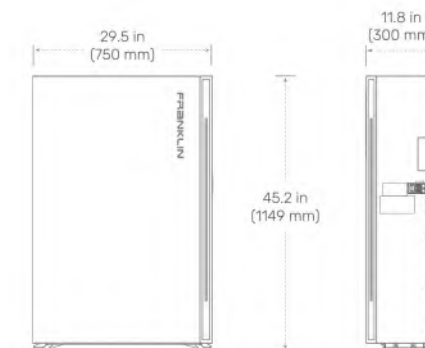

- At beginning of life: 3 kW charge/discharge power, 77° F (25° C).
- At rated power of 11.5 kW.
- Tested in accordance with the CEC-weighted efficiency approach.
- For more details, please refer to the FranklinWH System Limited Warranty for End Users available in the Documentation Center on the FranklinWH website.
- If the selected PV module has an IMPV exceeding 15 A, the MPPT will automatically limit the current to 15 A. The total open-circuit voltage must not exceed the maximum input voltage of 600 V.
- The output performance is designed with reference to IEC 62040-3 (Uninterruptible Power Systems - Part 3: Method of specifying the performance and test requirements. A number of core indicators meet the requirements of high-performance UPS).

For aPower connection, use ONLY copper conductors, rated to a minimum of 194° F (90° C).

Address: 1731 Technology Dr., Suite 530 San Jose, CA 95110 Telephone: +1 888-837-2655 Email: info@franklinwh.com Website: www.franklinwh.com
Copyright FranklinWH Energy Storage Inc. All rights reserved. The Franklin logo, FranklinWH, and other trademarks or service names are the trademarks of FranklinWH Energy Storage Inc. The document is for informational purposes only, data subject to change. 2026-02-12

WWW.FRANKLINWH.COM

FRANKLINWH



BUILDING DEPARTMENT SEAL STAMP



CONTACT: (561) 660-5200
6801 LAKE WORTH ROAD SUITE 302
LAKE WORTH, FL 33467
FLORIDA REGISTRY# 33809



CONTACT: (352) 554-7033
4509 NORTHWEST 23RD AVENUE,
GAINESVILLE, FL, 32606
SOLAR CONTRACTOR LICENSE: CVC56761

HALEY, PATRICIA

7115 SOUTHWEST HERLONG
STREET, FORT WHITE, FL, 32038
29.986761, -82.742427

SIGNATURE WITH SEAL

INVERTER DATASHEET

PV-11



TS4-A-F

Module-level rapid shutdown

The TS4-A-F (Fire Safety) is the advanced add-on rapid shutdown solution that brings smart module functionality to standard PV modules for higher reliability. Ensure safety by upgrading existing PV systems or by adding safety features to new installations.

The TS4-A-F complies with NEC 2017, 2020, and 2023 690.12 Rapid Shutdown specifications when installed with the Tigo RSS Transmitter or an inverter with a built-in Tigo certified transmitter.

Features

- High input current rating – now rated for 20 A I_{MP} /25 A I_{SC} to better accommodate bifacial and high-current modules
- Simple, fast installation – snaps to a standard PV module frame or mounts to racking
- Power-line communications (PLC) signaling – rapid shutdown signaling over PV conductors
- Automatic shutdown – PV array enters rapid shutdown mode in the event of AC grid loss
- UL Standards-certified – tested and certified with hundreds of top inverter models
- 25-year warranty

Specifications

	20 A	25 A
Electrical		
Maximum current (I_{MP}/I_{SC})	15 A/20 A	20 A/25 A
Input voltage range (V_{MP})	16 – 80 V	
Maximum input voltage	80 V	
Maximum system voltage (V_{MAX})	1000 V/1500 V*	
Maximum output current (I_{MAX})	15 A	20 A
Maximum output power (P_{MAX})	700 W	
Maximum efficiency	99.9%	
Recommended fuse rating	25 A	30 A
Rapid Shutdown		
TS4 conductor AWG	12	
Rapid shutdown time limit	<30 sec.	
PVRSE-controlled conductor limits	≤ 240 VA, ≤ 8 A, ≤ 30 V _{DC}	
UL 1741-compliant PVRSE	Yes	
Communications	PLC	
Connections		
Input (from module) cable lengths	0.12/0.62 m	
Output (to string) cable lengths	1.2/2 m	
Connectors	MC4/EVO2	

* Depending on UL/IEC certification



tigoenergy.com

©20241204 Tigo Energy, Inc. 002-00093-00 Rev. 3.5



Specifications

	20 A	25 A
Environmental		
Operating temperature range	-40 – 85 °C (-40 – 185 °F)*	
Storage temperature range	-40 – 85 °C (-40 – 185 °F)	
Maximum elevation	3000 m (9840 ft.)	
Outdoor IP rating	IP68/NEMA 3R	
Mechanical		
Dimensions (H/W/D)	139.7 x 138.4 x 22.9 mm (5.4 x 5.5 x 0.9 in.)	
Weight	490 g (1.1 lb.)	
General		
Standards compliance	UL 1741 PVSRE, UL 1741 PVRSS, CSA 22.2, IEC 62109, NEC 690.12	
Warranty	25 years	

* 20 A UL rating: -30 – 75 °C (-22 – 167 °F)

More Resources



Ordering Information

Part Number	V _{MAX} Certifications UL/IEC	Cable Lengths	Connectors
20 A I_{SC}			
481-00252-20	1500 V/1000 V	1.2/2 m	MC4
481-00252-32	1500 V/1000 V	0.12/1.2 m	MC4
481-00252-62	1500 V/1000 V	0.62/1.2 m	MC4
481-00261-32	1500 V/1500 V	0.12/1.2 m	EVO2
481-00261-62	1500 V/1500 V	0.62/1.2 m	EVO2
481-01252-32	1500 V/1000 V	0.12/1.2 m	MC4
481-01252-62	1500 V/1000 V	0.62/1.2 m	MC4
481-01261-32	1500 V/1500 V	0.12/1.2 m	EVO2
481-01261-62	1500 V/1500 V	0.62/1.2 m	EVO2
25 A I_{SC}			
486-00252-32	1500 V/1000 V	0.12/1.2 m	MC4
486-00252-62	1500 V/1000 V	0.62/1.2 m	MC4
486-00261-32	1500 V/1500 V	0.12/1.2 m	EVO2
486-00261-62	1500 V/1500 V	0.62/1.2 m	EVO2
488-00252-32	1000 V*	0.12/1.2 m	MC4
488-00252-62	1000 V*	0.62/1.2 m	MC4
488-00261-32	1500 V*	0.12/1.2 m	EVO2
488-00261-62	1500 V*	0.62/1.2 m	EVO2

* IEC certified only

tigoenergy.com

TS4-A-F Specifications and Ordering Information

BUILDING DEPARTMENT SEAL STAMP



CONTACT: (561) 660-5200
6801 LAKE WORTH ROAD SUITE 302
LAKE WORTH, FL 33467
FLORIDA REGISTRY# 33809



CONTACT: (352) 554-7033
4509 NORTHWEST 23RD AVENUE,
GAINESVILLE, FL, 32606
SOLAR CONTRACTOR LICENSE: CVC56761

HALEY, PATRICIA

7115 SOUTHWEST HERLONG
STREET, FORT WHITE, FL, 32038
29.986761, -82.742427

SIGNATURE WITH SEAL

RSS DATASHEET

PV-12



RSS TRANSMITTER - PCBA

Integrated Transmitter for Rapid Shutdown with TS4-F

The Tigo Rapid Shutdown System (RSS) Transmitter is part of a rapid shutdown solution when paired with Tigo TS4-F (Fire Safety), a PV module rapid shutdown unit. While powered on, the RSS Transmitter sends a signal to the TS4-F units to keep their PV modules connected and supplying energy. The RSS Transmitter can be integrated with an inverter for quick and easy installation.

TS4-F units automatically enter rapid shutdown mode when the RSS Transmitter is switched off and resume energy production when power is restored to the RSS Transmitter. This solution complies with NEC 690.12 specifications for 2014, 2017, and 2020 and uses PLC signaling for rapid shutdown.

The RSS Transmitter PCBA includes one or two RSS Cores, and requires 12V_{DC} power from an internal inverter source or a separate PVRSS-certified power supply, also available for order through Tigo.

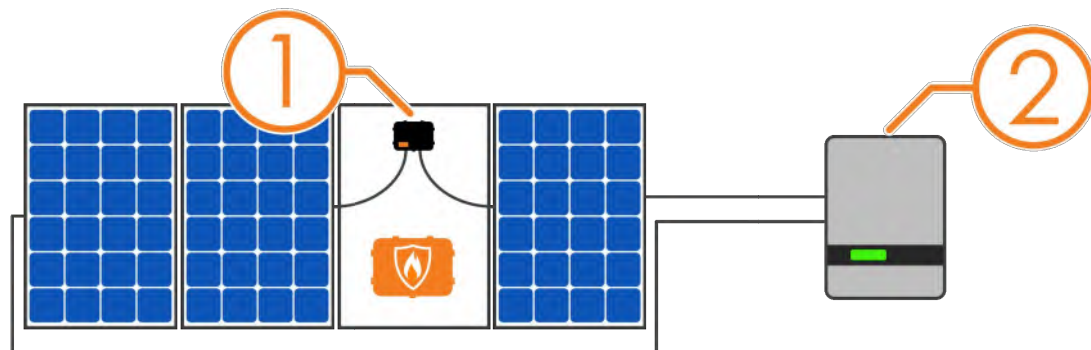

1. Modules equipped with Tigo TS4-F (Fire Safety)
2. Inverter with integrated RSS Transmitter

11/20/20

RSS TRANSMITTER - PCBA

- Meets NEC 690.12 requirements
- Module-level deactivation with TS4-F
- Automatic or manual shutdown
- Includes one or two RSS Cores
- Designed for inverter integration

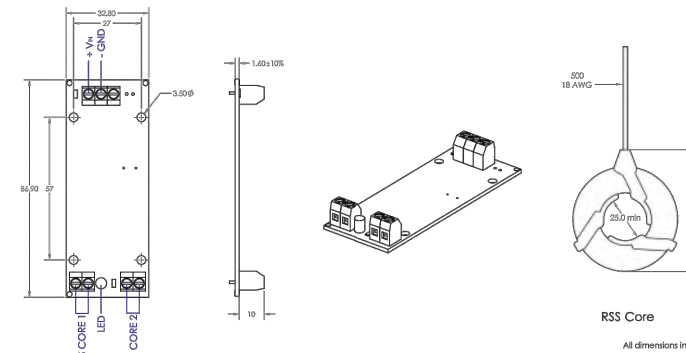

Input
Transmitter Input Voltage: 12V _{DC} (+/- 2%)
Transmitter Input Current: 1A
RSS Core
Max Current: 150A per RSS Core (Single Core: 150A, Dual Core: 300A)
Max String Voltage: 1500V _{DC}
Max Number of Strings per Core: 10
Max Supported PV Modules per String: 30
Environmental
Operating Temperature Range: -40°C to 85°C (PCBA)

For Tigo RSS Transmitter integration inside an inverter, be able to provide the following power profile:

- Voltage: 12V_{DC} (+/- 2%)
- Power Average: 0.85W
- Power Standby: 0.06W
- Duty Cycle: 15%
- Max Power: 5.5W

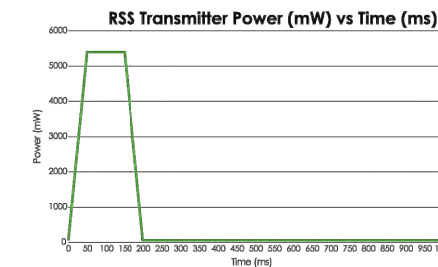

ORDERING OPTIONS

490-00100-10	Single RSS Core, RSS Transmitter PCBA
490-00100-20	Dual RSS Core, RSS Transmitter PCBA
983-01512-00	DIN Rail Power Supply, 12V _{DC} , 1.25A

For sales info:
sales@tigoenergy.com or 1.408.402.0802

For technical information:
http://support.tigoenergy.com

For product info:
Visit www.tigoenergy.com/products

For technical info:
http://support.tigoenergy.com

For additional info and product selection assistance, use Tigo's online design tool at www.tigoenergy.com/design



Tigo Energy, Inc. 655 Campbell Technology Pkwy Suite 150, Campbell, California 95008 USA
www.tigoenergy.com P: +1.408.402.0802 F: +1.408.358.6279 | sales@tigoenergy.com

BUILDING DEPARTMENT SEAL STAMP



CONTACT: (561) 660-5200
6801 LAKE WORTH ROAD SUITE 302
LAKE WORTH, FL 33467
FLORIDA REGISTRY# 33809



CONTACT: (352) 554-7033
4509 NORTHWEST 23RD AVENUE,
GAINESVILLE, FL, 32606
SOLAR CONTRACTOR LICENSE: CVC56761

HALEY, PATRICIA

7115 SOUTHWEST HERLONG
STREET, FORT WHITE, FL, 32038
29.986761, -82.742427

SIGNATURE WITH SEAL

TRANSMITTER DATASHEET

PV-13

FRANKLINWH

aGate

Intelligent energy management system

The aGate serves as the controller for all home power sources by interconnecting solar, grid, batteries, and a standby generator to supply electricity to the home. It seamlessly transitions the home supply from grid power to backup power so that always-on appliances, such as the refrigerator and network router, will not be affected when the grid goes down.

The aGate can be installed at the service entrance, connected to the main load center, or used as a load center.



Robust

- ✓ Micro-grid interconnect device (MID)
- ✓ EMS Integrated PV and grid metering
- ✓ UL1741 certified PCS function & 280A busbar to avoid Main Panel Upgrades
- ✓ 12-year limited warranty



Flexible

- ✓ Compatible with micro and string solar inverter
- ✓ Indoor and outdoor / wall-mounted



Hassle-free

- ✓ Precise control of electricity usage through Smart Circuits Module
- ✓ Standby generator integration via generator module
- ✓ Remarkable black start function ensures battery charge after a prolonged outage or extended trip
- ✓ Vehicle to loads (V2L) function to power essential home appliances during an emergency
- ✓ Commissioning through the aGate Wifi hotspot or Bluetooth



Easy installation

- ✓ Built-in design Smart Circuits and Generator Modules
- ✓ Conduit entry options from the bottom, left, or right

WWW.FRANKLINWH.COM



DATASHEET

PERFORMANCE SPECIFICATIONS

SKU	AGT-R1V3-US AGT-R1V3-CAN
Model Number	aGate X (US) aGate X 20 (CAN)
Coupling	AC-coupled
Nominal AC Voltage	120 / 208 V, 120 / 240 V, 60 Hz
Phase	2 W+N+PE
Grid Input Over Current Protection Device	200 A Max
aPower Over Current Protection Device	125 A Max
Solar Input Over Current Protection Device	80 A Max
Backup Load Port Over Current Protection Device	200 A Max
Non-backup Load Port Over Current Protection Device	200 A Max
Generator Over Current Protection Device ¹	200 A Max
Smart Circuits Over Current Protection Device ²	Opt. a 1 × 80 A Max @ 208 V / 240 V & 1 × 50 A Max @ 208 V / 240 V Opt. b 1 × 80 A Max @ 208 V / 240 V & 2 × 50 A Max @ 120 V
Maximum Supply Fault Current	22 kA
Busbar Rating	280 A
Work Modes	Self-Consumption, Time of Use, Emergency Backup
Communications	Ethernet / 4G / wifi / Bluetooth
User Interface	FranklinWH App
Warranty	12-year limited
IEC Protective Class	Class I
Over voltage Category	Category II
AC Meter	+/- 0.5%

MECHANICAL SPECIFICATIONS

Dimensions (H x W x D)	31.5 in x 21.7 in x 6.3 in (800 mm x 550 mm x 160 mm)
Weight	38.6 lb (17.5 kg)
Mounting	Wall mount

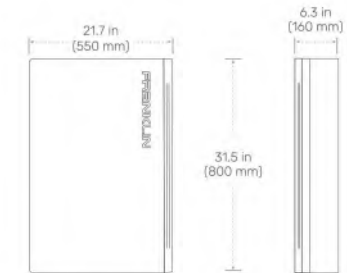

1. Generator Module is optional.
2. Smart Circuit Module is optional.
For aGate connection, use copper or aluminum wire, rated to a minimum of 167° F (75° C).

COMPLIANCE INFORMATION

Certifications	UL 1741, UL 1741 PCS, UL 67, UL 869A, UL 916, CAN / CSA C22.2 No. 107.1-16, CSA C22.2 No. 29, CSA C22.2 No. 0.19
Seismic	AC 156, OSHPD, IEEE 693-2005 (high)
Environmental	California Proposition 65 RoHS Directive 2011 / EU
Emissions	FCC Part 15 Class B, ICES 003

ENVIRONMENTAL SPECIFICATIONS

Enclosure Type	NEMA Type 3R
Operating Temperature	-4°F to 122°F (-20°C to 50°C)
Operating Humidity (RH)	Up to 100% RH, condensing
Altitude	Maximum 9,843 ft (3,000 m)
Environment	Indoor and outdoor rated

Franklin Home Power Solution

Whole Home Backup

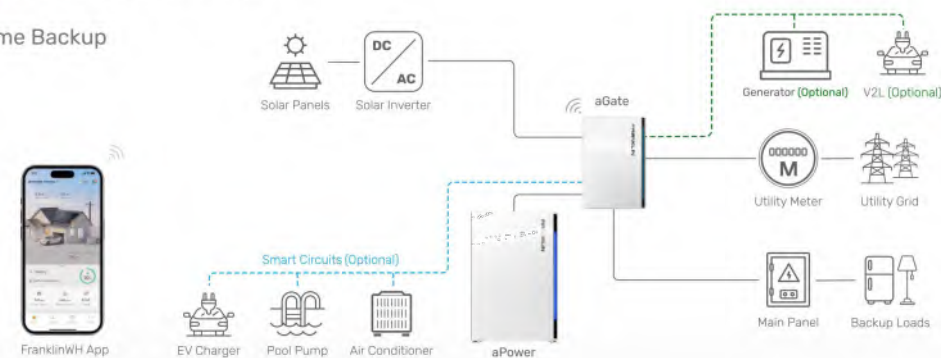

The aGate X 1.3.1 (SKU: AGT-R1V3-US) is available in United States and Canada. For product availability in other regions, please visit our official website or contact a local authorized dealer.

Address: 1731 Technology Dr., Suite 530 San Jose, CA 95110 Telephone: +1 888-837-2655 Email: info@franklinwh.com Website: www.franklinwh.com
Copyright 2025 FranklinWH Energy Storage Inc. All rights reserved. The Franklin logo, FranklinWH, and other trademarks or service names are the trademarks of FranklinWH Energy Storage Inc. The document is for informational purposes only, data subject to change. 2025-10-11

WWW.FRANKLINWH.COM

FRANKLINWH

BUILDING DEPARTMENT SEAL STAMP



CONTACT: (561) 660-5200
6801 LAKE WORTH ROAD SUITE 302
LAKE WORTH, FL 33467
FLORIDA REGISTRY# 33809



CONTACT: (352) 554-7033
4509 NORTHWEST 23RD AVENUE,
GAINESVILLE, FL, 32606
SOLAR CONTRACTOR LICENSE: CVC56761

HALEY, PATRICIA

7115 SOUTHWEST HERLONG
STREET, FORT WHITE, FL, 32038
29.986761, -82.742427

SIGNATURE WITH SEAL

GATEWAY DATASHEET

PV-14



Roof Mount System

Datasheet



Built for solar's toughest roofs.

IronRidge builds the strongest roof mounting system in solar. Every component has been tested to the limit and proven in extreme environments.

Our rigorous approach has led to unique structural features, such as curved rails and reinforced flashings, and is also why our products are fully certified, code compliant and backed by a 20-year warranty.



Strength Tested

All components evaluated for superior structural performance.



Class A Fire Rating

Certified to maintain the fire resistance rating of the existing roof.



Integrated Grounding

UL 2703 system eliminates separate module grounding components.



PE Certified

Pre-stamped engineering letters available in most states.



Design Software

Online tool generates a complete bill of materials in minutes.



20 Year Warranty

Twice the protection offered by competitors.

XR Rails

Datasheet

XR10 Rail

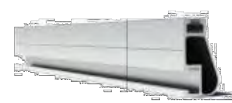

A low-profile mounting rail for regions with light snow.

- 6' spanning capability
- Moderate load capability
- Clear & black anod. finish

XR100 Rail



The ultimate residential solar mounting rail.

- 8' spanning capability
- Heavy load capability
- Clear & black anod. finish

XR1000 Rail



A heavyweight mounting rail for commercial projects.

- 12' spanning capability
- Extreme load capability
- Clear anodized finish

Internal Splices



All rails use internal splices for seamless connections.

- Self-tapping screws
- Varying versions for rails
- Grounding Straps offered

Attachments

FlashFoot



Anchor, flash, and mount with all-in-one attachments.

- Ships with all hardware
- IBC & IRC compliant
- Certified with XR Rails

Slotted L-Feet



Drop-in design for rapid rail attachment.

- High-friction serrated face
- Heavy-duty profile shape
- Clear & black anod. finish

Standoffs



Raise flush or tilted systems to various heights.

- Works with vent flashing
- Ships pre-assembled
- 4" and 7" Lengths

Tilt Legs



Tilt assembly to desired angle, up to 45 degrees.

- Attaches directly to rail
- Ships with all hardware
- Fixed and adjustable

Clamps & Grounding

End Clamps



Slide in clamps and secure modules at ends of rails.

- Mill finish & black anod.
- Sizes from 1.22" to 2.3"
- Optional Under Clamps

Grounding Mid Clamps



Attach and ground modules in the middle of the rail.

- Parallel bonding T-bolt
- Reusable up to 10 times
- Mill & black stainless

T-Bolt Grounding Lugs



Ground system using the rail's top slot.

- Easy top-slot mounting
- Eliminates pre-drilling
- Swivels in any direction

Accessories



Provide a finished and organized look for rails.

- Snap-in Wire Clips
- Perfected End Caps
- UV-protected polymer

Free Resources



Design Assistant

Go from rough layout to fully engineered system. For free. Go to IronRidge.com/rm



NABCEP Certified Training

Earn free continuing education credits, while learning more about our systems. Go to IronRidge.com/training

BUILDING DEPARTMENT SEAL STAMP



CONTACT: (561) 660-5200
6801 LAKE WORTH ROAD SUITE 302
LAKE WORTH, FL 33467
FLORIDA REGISTRY# 33809



CONTACT: (352) 554-7033
4509 NORTHWEST 23RD AVENUE,
GAINESVILLE, FL, 32606
SOLAR CONTRACTOR LICENSE: CVC56761

HALEY, PATRICIA

7115 SOUTHWEST HERLONG
STREET, FORT WHITE, FL, 32038
29.986761, -82.742427

SIGNATURE WITH SEAL

RACKING DATASHEET

PV-15

S-5![®]

The Right Way![®]

Introducing the new SolarFoot™ for exposed fastener metal roofing with the strength, testing, quality, and time-proven integrity you expect from S-5!. The SolarFoot provides an ideal mounting platform to attach the L-Foot (not included) of a rail-mounted PV system to the roof. This solution is The Right Way to secure rail-mounted solar systems to exposed fastener metal such as AG-Panel or R-Panel.

The right way to attach almost anything to metal roofs!

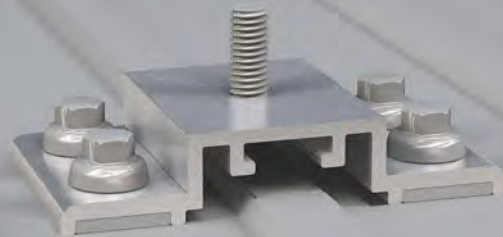

SolarFoot Features:

- Manufactured in the U.S.A. from certified raw material
- Fabricated in our own ISO 9002 certified factory
- All aluminum and stainless components
- Lifetime limited warranty
- Compatible with all commercial L-Foot products on the market
- Factory applied 40-year isobutylene/isoprene crosslink polymer sealant for reliable weathertightness
- Sealant reservoir to prevent over compression of sealant
- Load-to-failure tested Normal to Seam by a nationally accredited laboratory on thousands of metal roof manufacturers, profiles and materials
- Four points of attachment into structure or deck with tested holding strength for engineered applications
- Integrated with M8-1.25x17mm stud and M8-1.25 stainless steel hex flange nut included

888-825-3432 | www.S-5.com | 

S-5![®]

The Right Way![®]

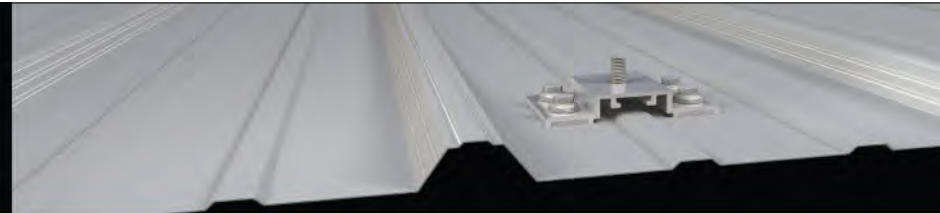

SolarFoot™: Mounting for Exposed Fastener Roofing

The SolarFoot is a simple, cost-effective pedestal for L-Foot (not included) attachment of rail-mounted solar PV. The unique design is compatible with all rail producer L-Foot components. The new SolarFoot assembly ensures a durable weathertight solution for the life of the roof. Special factory applied butyl co-polymeric sealant contained in a reservoir is The Right Way, allowing a water-tested seal. Stainless integrated stud and hex flange lock-nut secure the L-Foot into position. A low center of gravity reduces the moment arm commonly associated with L-Foot attachments. Direct attachment of the SolarFoot to the structural member or deck provides unparalleled holding strength.

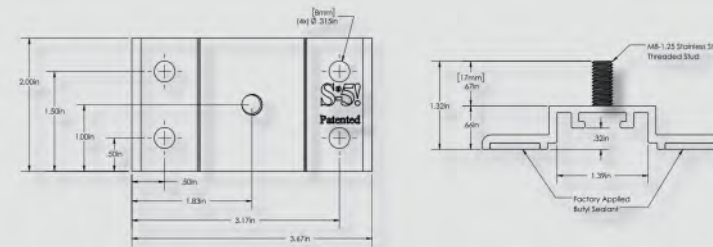

*Fasteners sold separately. Fastener type varies with substrate. Contact S-5! on how to purchase fasteners and obtain our test results. L-Foot also sold separately.

Fastener Selection



Metal to Metal:
1/4-14 Self Drilling Screw
1-1/2" to 2-1/2"



Metal to Wood:
1/4-14 Type 17 AB Milled Point
1-1/2" to 2-1/2"

To source fasteners for your projects, contact S-5!

When other brands claim to be "just as good as S-5!", tell them to PROVE IT.

SolarFoot Advantages:

Exposed fastener mounting platform for solar arrays attached via L-Foot and Rails

Weatherproof attachment to exposed fastener roofing

Butyl sealant reservoir provides long-term waterproof seal

M8-1.25x17mm stud with M8 hex flange nut for attachment of all popular L-Foot/rail combinations

Tool: 13 mm Hex Socket or 1/2" Hex Socket

Electric screw gun with hex drive socket for self tapping screws

Low Center of Gravity reduces moment arm commonly associated with L-Foot/Rail solar mounting scenarios

Attaches directly to structure or deck for optimal holding strength

S-5! Recommended substrate-specific (e.g. steel purlin, wood 2x4, OSB, etc.) fasteners provide excellent waterproofing and pull out strength

Fastener through-hole locations comply with NDS (National Design Specification) for Wood Construction

S-5![®] Warning! Please use this product responsibly!

The independent lab test data found at www.S-5.com can be used for load-critical designs and applications.

Products are protected by multiple U.S. and foreign patents. For published data regarding holding strength, fastener torque, patents, and trademarks, visit the S-5! website at www.S-5.com. Copyright 2021, Metal Roof Innovations, Ltd. S-5! products are patent protected.

Copyright 2021, Metal Roof Innovations, Ltd. Version 083121

Distributed by:

BUILDING DEPARTMENT SEAL STAMP



CONTACT: (561) 660-5200
6801 LAKE WORTH ROAD SUITE 302
LAKE WORTH, FL 33467
FLORIDA REGISTRY# 33809



CONTACT: (352) 554-7033
4509 NORTHWEST 23RD AVENUE,
GAINESVILLE, FL, 32606
SOLAR CONTRACTOR LICENSE: CVC56761

HALEY, PATRICIA

7115 SOUTHWEST HERLONG
STREET, FORT WHITE, FL, 32038
29.986761, -82.742427

SIGNATURE WITH SEAL

ATTACHMENT DATASHEET

PV-16

Simplified Grounding for Every Application

The UFO family of components eliminates the need for separate grounding hardware by bonding solar modules directly to IronRidge XR Rails. All system types that feature the UFO family—Flush Mount, Tilt Mount and Ground Mount—are fully listed to the UL 2703 standard.

UFO hardware forms secure electrical bonds with both the module and the rail, resulting in many parallel grounding paths throughout the system. This leads to safer and more reliable installations.

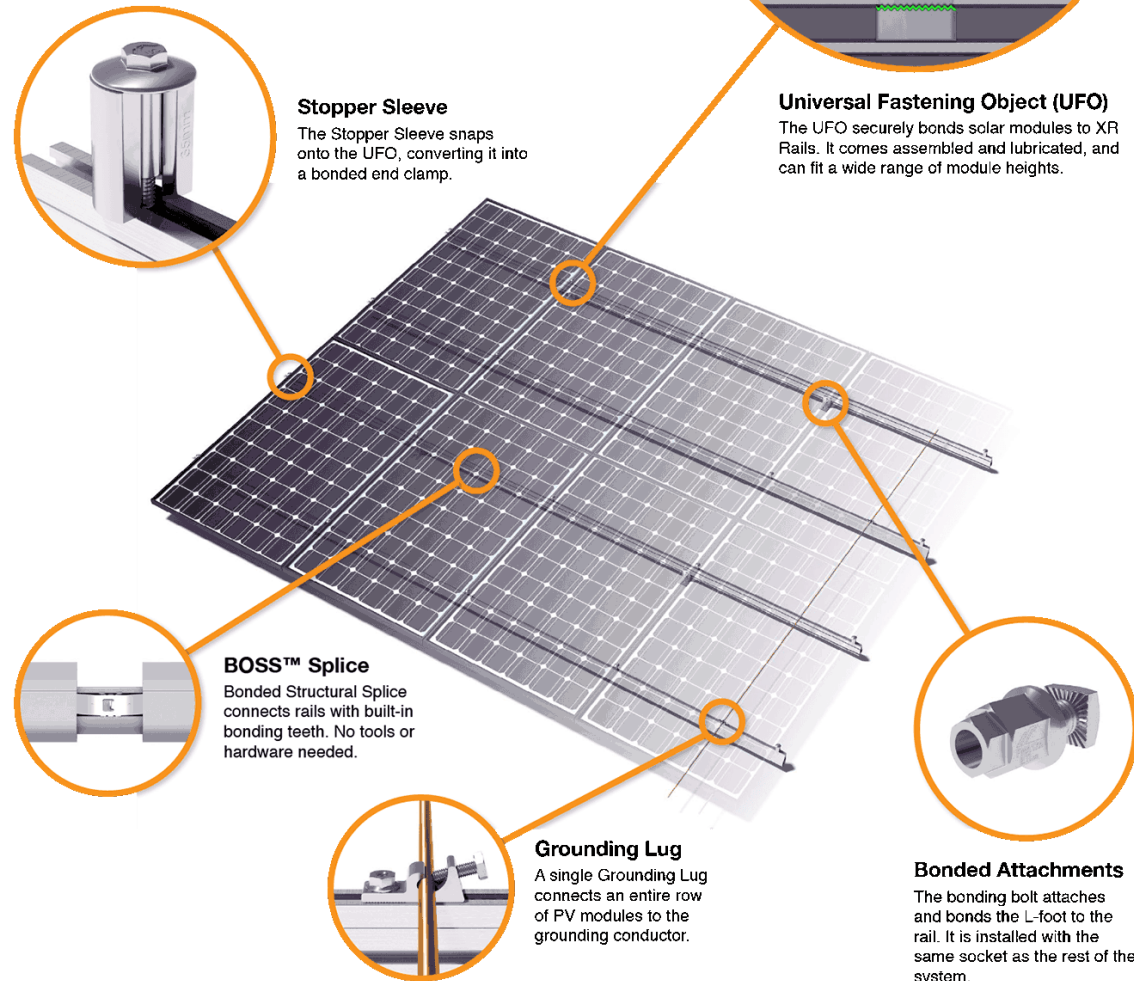

System Diagram

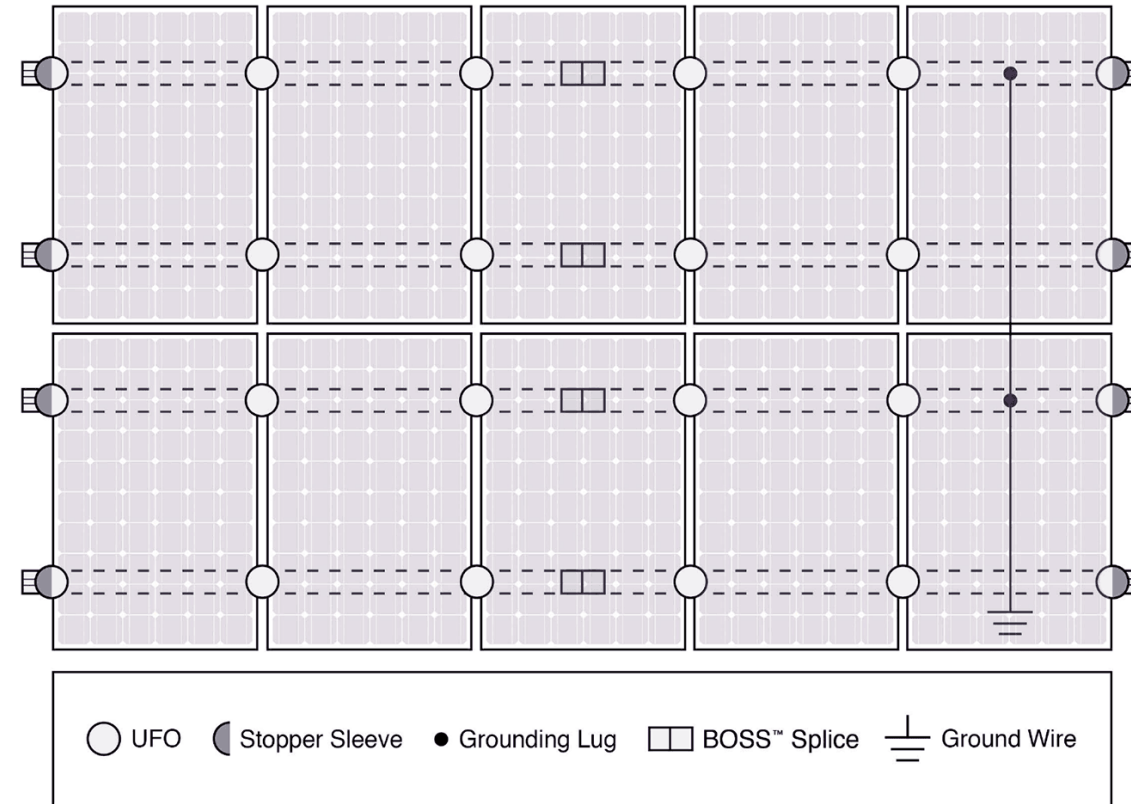

Approved Enphase microinverters can provide equipment grounding of IronRidge systems, eliminating the need for grounding lugs and field installed equipment ground conductors (EGC). A minimum of two microinverters mounted to the same rail and connected to the same Engage cable is required. Refer to installation manuals for additional details.

UL Certification

The IronRidge Flush Mount, Tilt Mount, and Ground Mount Systems have been listed to UL 2703 by Intertek Group plc.

UL 2703 is the standard for evaluating solar mounting systems. It ensures these devices will maintain strong electrical and mechanical connections over an extended period of time in extreme outdoor environments.

Go to IronRidge.com/UFO

Cross-System Compatibility			
Feature	Flush Mount	Tilt Mount	Ground Mount
XR Rails	✓	✓	XR1000 Only
UFO/Stopper	✓	✓	✓
BOSS™ Splice	✓	✓	N/A
Grounding Lugs	1 per Row	1 per Row	1 per Array
Microinverters & Power Optimizers	Enphase - M250-72, M250-60, M215-60, C250-72 Darfon - MIG240, MIG300, G320, G640 SolarEdge - P300, P320, P400, P405, P600, P700, P730		
Fire Rating	Class A	Class A	N/A
Modules	Tested or Evaluated with over 400 Framed Modules Refer to installation manuals for a detailed list.		

BUILDING DEPARTMENT SEAL STAMP



CONTACT: (561) 660-5200
6801 LAKE WORTH ROAD SUITE 302
LAKE WORTH, FL 33467
FLORIDA REGISTRY# 33809



CONTACT: (352) 554-7033
4509 NORTHWEST 23RD AVENUE,
GAINESVILLE, FL, 32606
SOLAR CONTRACTOR LICENSE: CVC56761

HALEY, PATRICIA

7115 SOUTHWEST HERLONG
STREET, FORT WHITE, FL, 32038
29.986761, -82.742427

SIGNATURE WITH SEAL