

# COLUMBIA COUNTY Property Appraiser

## Parcel 08-4S-17-08249-001

### Owners

DE JESUS JULIA  
175 SW MICHIGAN ST  
LAKE CITY, FL 32025

### Parcel Summary

Location	175 SW MICHIGAN ST
Use Code	0100: SINGLE FAMILY
Tax District	2: COUNTY
Acreage	.5900
Section	08
Township	4S
Range	17
Subdivision	LAKESDE HT

### Legal Description

BEG SW COR BLOCK 7 LAKESIDE HEIGHTS S/D,  
RUN N 200 FT, E 130 FT, S 200 FT, W 130 FT  
TO POB, BEING A PART OF BLOCK 7 LAKESIDE  
HEIGHTS S/D.

DC 965-1859, 965-1860, WD 1147-141,  
WD 1380-1382,

### Working Values

	2026
Total Building	\$109,115
Total Extra Features	\$1,200
Total Market Land	\$44,400
Total Ag Land	\$0



	2026
Total Market	\$154,715
Total Assessed	\$154,715
Total Exempt	\$0
Total Taxable	\$154,715
SOH Diff	\$0

## Value History

	2025	2024	2023	2022	2021	2020
Total Building	\$109,115	\$102,303	\$93,528	\$80,864	\$75,020	\$62,353
Total Extra Features	\$1,200	\$1,200	\$1,200	\$1,200	\$1,200	\$1,200
Total Market Land	\$44,400	\$44,400	\$44,400	\$36,000	\$26,640	\$26,505
Total Ag Land	\$0	\$0	\$0	\$0	\$0	\$0
Total Market	\$154,715	\$147,903	\$139,128	\$118,064	\$102,860	\$90,058
Total Assessed	\$145,039	\$131,854	\$119,867	\$108,970	\$99,064	\$90,058
Total Exempt	\$0	\$0	\$0	\$0	\$0	\$0
Total Taxable	\$145,039	\$131,854	\$119,867	\$108,970	\$99,064	\$90,058
SOH Diff	\$9,676	\$16,049	\$19,261	\$9,094	\$3,796	\$0

## Document/Transfer/Sales History

Instrument / Official Record	Date	Q/U .....	Reason	Type	V/I .....	Sale Price	Ownership
<u>WD</u> 1380/1382	2019-03-15	<u>Q</u>	<u>01</u>	WARRANTY DEED	Improved	\$95,000	Grantor: MARY ADELIA JOHNS LEMLEY Grantee: JULIA DE JESUS
<u>WD</u> 1147/0171	2008-03-31	<u>Q</u>		WARRANTY DEED	Improved	\$69,500	Grantor: JOHN PIERCE Grantee: MARY ADELIA JOHNS
<u>WD</u> 0965/1860	2002-10-21	<u>Q</u>		WARRANTY DEED	Improved	\$40,800	Grantor: CHARLES E RIDDLE Grantee: JOHN PIERCE

## Buildings

### Building # 1, Section # 1, 62353, SFR

Type	Models	Heated Sq Ft	Repl Cost New	YrBlt .....	Year Eff	Gross Area	Other % Dpr	Normal % Dpr	% Cond	Value
<u>0100</u>	<u>01</u>	1220	\$167,869	1950	1950	1,842	0.00%	35.00%	65.00%	\$109,115

## Structural Elements

Type	Description	Code	Details
EW	Exterior Wall	19	COMMON BRK
RS	Roof Structure	03	GABLE/HIP
RC	Roof Cover	03	COMP SHNGL
IW	Interior Wall	05	DRYWALL
IF	Interior Flooring	12	HARDWOOD
IF	Interior Flooring	15	HARDTILE
AC	Air Conditioning	03	CENTRAL
HT	Heating Type	04	AIR DUCTED
BDR	Bedrooms	3.00	
BTH	Bathrooms	2.00	
FR	Frame	01	NONE
STR	Stories	1.	1.
AR	Architectual Type	05	CONV
COND	Condition Adjustment	03	03
KTCH	Kitchen Adjustment	01	01

## Sub Areas

Type	Gross Area	Percent of Base	Adjusted Area
<u>BAS</u>	1,220	100%	1,220
<u>FOP</u>	100	30%	30
<u>PTO</u>	144	5%	7
<u>UCP</u>	294	20%	59
<u>UST</u>	84	45%	38

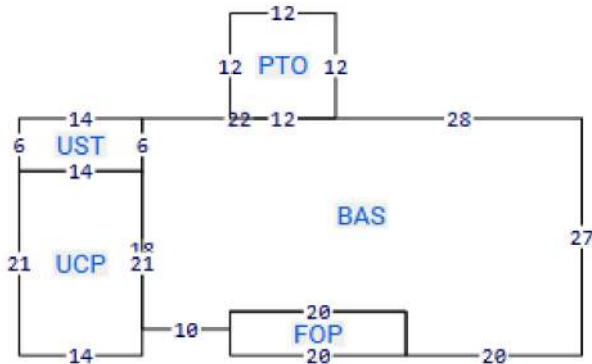

## Extra Features

Code	Description	Length	Width	Units	Unit Price	<u>AYB</u>	% Good Condition	Final Value
0296	SHED METAL			1.00	\$0.00	2012	100%	\$1,200

## Land Lines

Code	Description	Zone	Front	Depth	Units	Rate/Unit	Acreage	Total Adj	Value
0100	SFR	00	.00	.00	3.00	\$18,500.00/LT	0.59	0.80	\$44,400

## Personal Property

None

## Permits

None

## TRIM Notices

2025

2024

2023

## Disclaimer

All parcel data on this page is for use by the Columbia County Assessor for assessment purposes only. The summary data on this page may not be a complete representation of the parcel or of the improvements thereon. Building information, including unit counts and number of permitted units, should be verified with the appropriate building and planning agencies. Zoning information should be verified with the appropriate planning agency. All parcels are reappraised each year. This is a true and accurate copy of the records of the Columbia County Assessor's Office as of February 27, 2026.