



DEPARTMENT OF REGULATORY AND ECONOMIC RESOURCES (RER)
BOARD AND CODE ADMINISTRATION DIVISION

MIAMI-DADE COUNTY
PRODUCT CONTROL SECTION
11805 SW 26 Street, Room 208
Miami, Florida 33175-2474
T (786) 315-2590 F (786) 315-2599

www.miamidade.gov/economy

NOTICE OF ACCEPTANCE (NOA)

TAMKO Building Products LLC
220 West 4th Street
Joplin, MO 64801

SCOPE:

This NOA is being issued under the applicable rules and regulations governing the use of construction materials. The documentation submitted has been reviewed and accepted by Miami-Dade County RER -Product Control Section to be used in Miami-Dade County and other areas where allowed by the Authority Having Jurisdiction (AHJ).

This NOA shall not be valid after the expiration date stated below. The Miami-Dade County Product Control Section (in Miami-Dade County) and/or the AHJ (in areas other than Miami-Dade County) reserve the right to have this product or material tested for quality assurance purposes. If this product or material fails to perform in the accepted manner, the manufacturer will incur the expense of such testing and the AHJ may immediately revoke, modify, or suspend the use of such product or material within their jurisdiction. RER reserves the right to revoke this acceptance, if it is determined by Miami-Dade County Product Control Section that this product or material fails to meet the requirements of the applicable building code.

This product is approved as described herein, and has been designed to comply with the Florida Building Code including the High Velocity Hurricane Zone of the Florida Building Code.

DESCRIPTION: TAMKO Roof Shingles

LABELING: Each unit shall bear a permanent label with the manufacturer's name or logo, city, state and following statement: "Miami-Dade County Product Control Approved", unless otherwise noted herein.

RENEWAL of this NOA shall be considered after a renewal application has been filed and there has been no change in the applicable building code negatively affecting the performance of this product.

TERMINATION of this NOA will occur after the expiration date or if there has been a revision or change in the materials, use, and/or manufacture of the product or process. Misuse of this NOA as an endorsement of any product, for sales, advertising or any other purposes shall automatically terminate this NOA. Failure to comply with any section of this NOA shall be cause for termination and removal of NOA.

ADVERTISEMENT: The NOA number preceded by the words Miami-Dade County, Florida, and followed by the expiration date may be displayed in advertising literature. If any portion of the NOA is displayed, then it shall be done in its entirety.

INSPECTION: A copy of this entire NOA shall be provided to the user by the manufacturer or its distributors and shall be available for inspection at the job site at the request of the Building Official.

This NOA renews NOA# 24-0521.04 and consists of pages 1 through 7.
The submitted documentation was reviewed by Alex Tigera.

11/26/25



NOA No.: 25-1114.01
Expiration Date: 12/01/30
Approval Date: 11/26/25
Page 1 of 7

ROOFING ASSEMBLY APPROVAL

Category:	Roofing
Sub-Category:	Asphalt Shingles
Materials:	Laminate
Deck Type:	Wood

SCOPE

This approves TAMKO's Heritage, Proline Titan XT, StormFighter Flex 3 and StormFighter Flex 4 asphalt shingles, manufactured by TAMKO Building Products LLC, as described in this Notice of Acceptance and designed to comply with the Florida Building Code High Velocity Hurricane Zones.

PRODUCT DESCRIPTION

<u>Product</u>	<u>Dimensions</u>	<u>Test Specifications</u>	<u>Product Description</u>
Heritage <i>Manufacturing Location # 1, 2, 3, 4, 5</i>	13 1/4" x 39 3/8"	TAS 110	Dimensional asphalt shingle.
Proline Titan XT <i>Manufacturing Location # 1, 2, 3, 4, 5</i>	13 1/4" x 39 3/8"	TAS 110	Dimensional asphalt shingle.
StormFighter Flex 3 <i>Manufacturing Location # 4</i>	13-1/4" x 39-3/8"	TAS 110	Dimensional asphalt shingle.
StormFighter Flex 4 <i>Manufacturing Location # 4</i>	13-1/4" x 39-3/8"	TAS 110	Dimensional asphalt shingle.

MANUFACTURING LOCATIONS

1. Dallas, TX
2. Tuscaloosa, AL
3. Frederick, MD
4. Phillipsburg, KS
5. Joplin, MO



EVIDENCE SUBMITTED

<u>Test Agency</u>	<u>Test Identifier</u>	<u>Test Name/Report</u>	<u>Date</u>
Underwriters Laboratories, Inc.	ASTM D 3462 & TAS 107	R2919 Letter	03/10/11
	ASTM D3462	4789110543	08/26/14
	TAS 107	4789110543	02/19/15
	ASTM E 108	4789110543	08/26/14
	ASTM D3161, Class F	4787043752	10/20/15
	ASTM D 3462	4789650787	10/12/20
	ASTM D 3462 & TAS 107	R 2919 Letter	10/15/20
	ASTM D 3462	4789682154	10/15/20
	ASTM D 3462 & TAS 107	4790199059	10/23/20
	ASTM D 3462 & TAS 107	4790369598	07/05/22
	ASTM D 3462 & TAS 107	4790261834	02/07/23
	ASTM D 3462 & TAS 107	4789650787 (test record 2)	03/11/22
	ASTM D 3462 & TAS 107	R 2919	10/12/23
	PRI Asphalt Technologies, Inc.	TAS 100	TAP-129-02-01
TAS 100		TAP-130-02-01	05/26/05
TAS 100		TAP-131-02-01	05/26/05
PRI Construction Materials Technologies LLC	TAS 100	TAP-303-02-01	12/12/14
	TAS 100	TAP-307-02-01	02/10/15
	TAS 100	TAP-317-02-01	09/02/15
Farabaugh Engineering and Testing Inc.	TAS 100	T319-22	11/14/22
	TAS 100	T320-22	11/14/22

LIMITATIONS

1. Fire classification is not part of this acceptance; refer to a current Approved Roofing Materials Directory for fire ratings of this product.
2. Shingles shall not be installed on roof mean heights in excess of 33 ft.
3. All products listed herein shall have a quality assurance audit in accordance with the Florida Building Code and Rule 61G20-3 of the Florida Administrative Code.

INSTALLATION

1. Shingles shall be installed in compliance with Roofing Application Standard RAS 115.
2. Flashing shall be in accordance with Roofing Application Standard RAS 115.
3. The manufacturer shall provide clearly written application instructions.
4. Exposure and course layout shall be in compliance with Detail 'A', attached.
5. Nailing shall be in compliance with Details 'B', attached.

LABELING

Shingles shall be permanently labeled with the manufacturer's name and/or logo, city and state of manufacturing facility, and the following statement: "Miami-Dade County Product Control Approved" **or** with the Miami-Dade County Product Control Seal as seen below:



NOA No.: 25-1114.01
 Expiration Date: 12/01/30
 Approval Date: 11/26/25
 Page 3 of 7

BUILDING PERMIT REQUIREMENTS

As required by the Building Official or the applicable Building Code in order to properly evaluate the installation of this system. This Notice of Acceptance on its own cannot be used to obtain a building permit.

DETAIL A

HERITAGE, PROLINE TITAN XT, STORMFIGHTER FLEX 3, AND STORMFIGHTER FLEX 4

All dimensions are in inches.

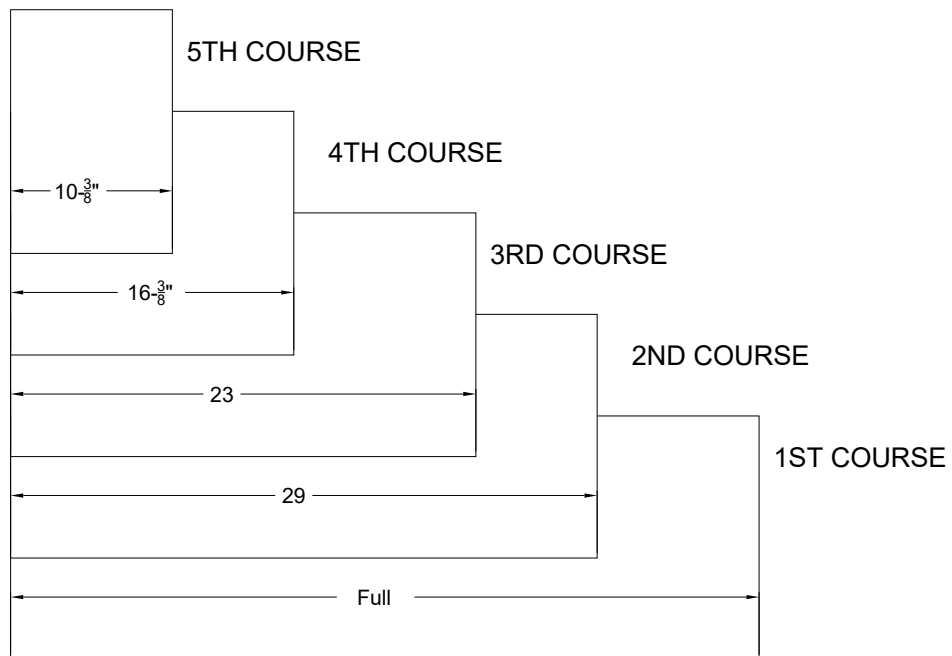

DETAIL B

HERITAGE, PROLINE TITAN XT, STORMFIGHTER FLEX 3, AND STORMFIGHTER FLEX 4

FIG. 1 FASTENING PATTERN

All dimensions are in inches

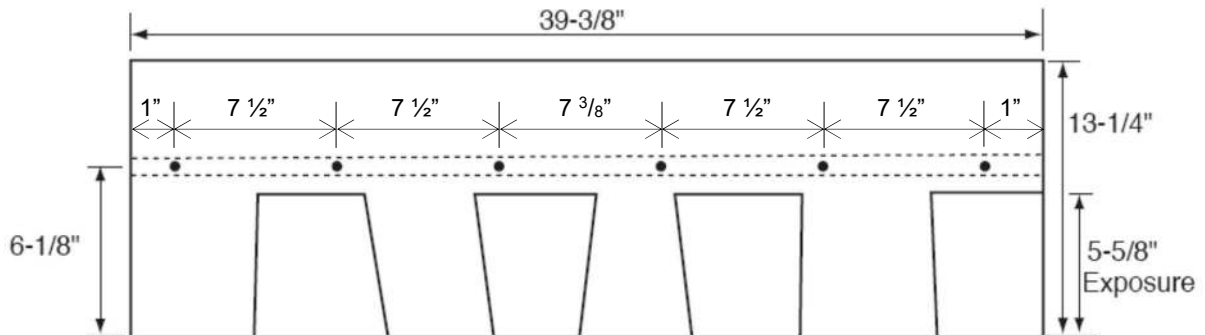

DETAIL B (CONTINUED)

HERITAGE, PROLINE TITAN XT, AND STORMFIGHTER FLEX 3, AND STORMFIGHTER FLEX 4 SHINGLES

FIG. 2 ALTERNATE FASTENING PATTERN

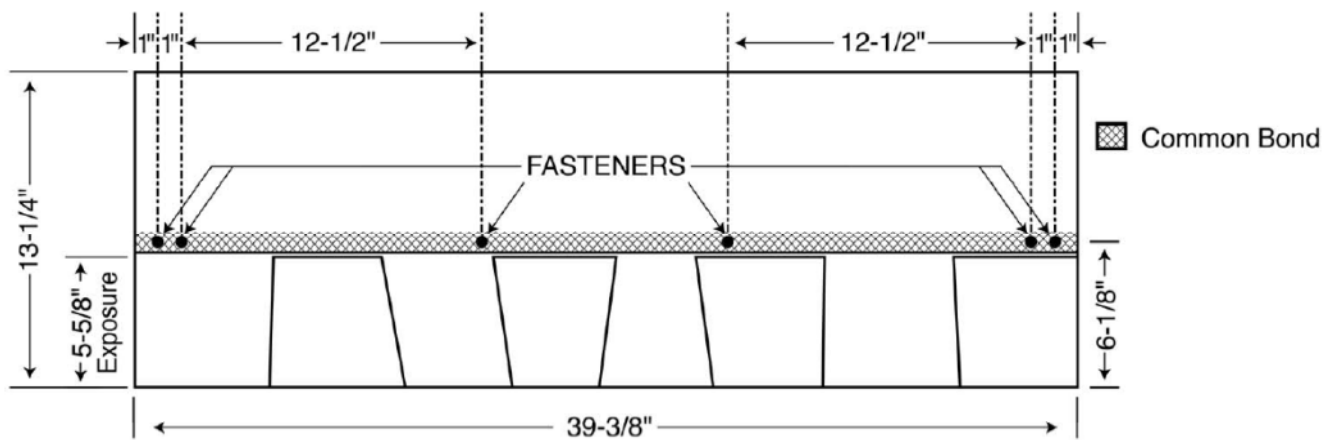

**HERITAGE SHINGLE
(TUSCALOOSA, AL)**

FIG. 3 ALTERNATE FASTENING PATTERN

**HORIZONTAL NAIL SPACING IN ACCORDANCE WITH FIG. 1 OR FIG. 2.
VERTICAL NAIL SPACING ALLOWED ANYWHERE WITHIN NAIL ZONE.
(OPTION 1)**

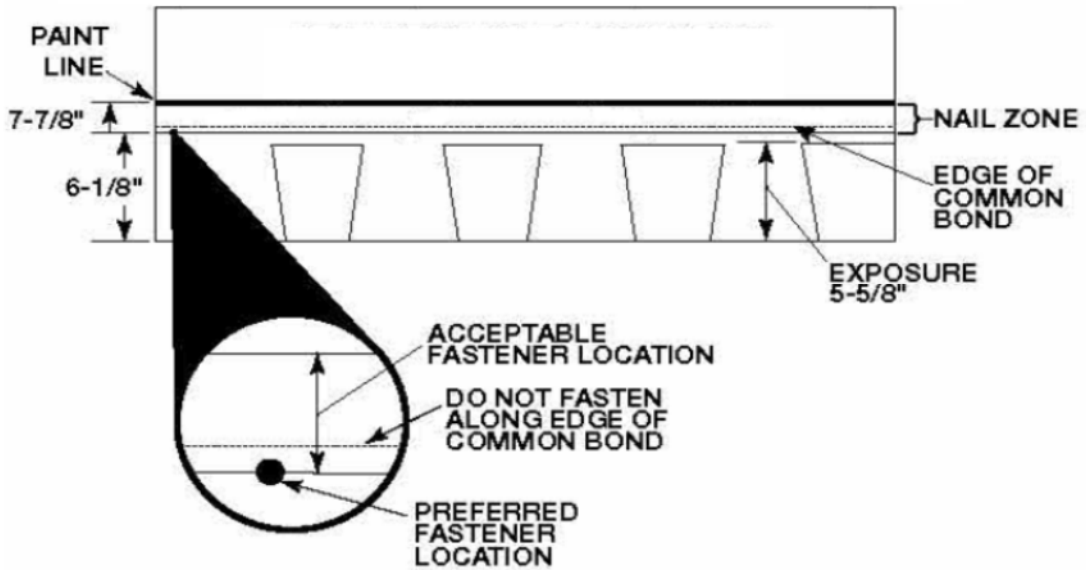

(OPTION 2)

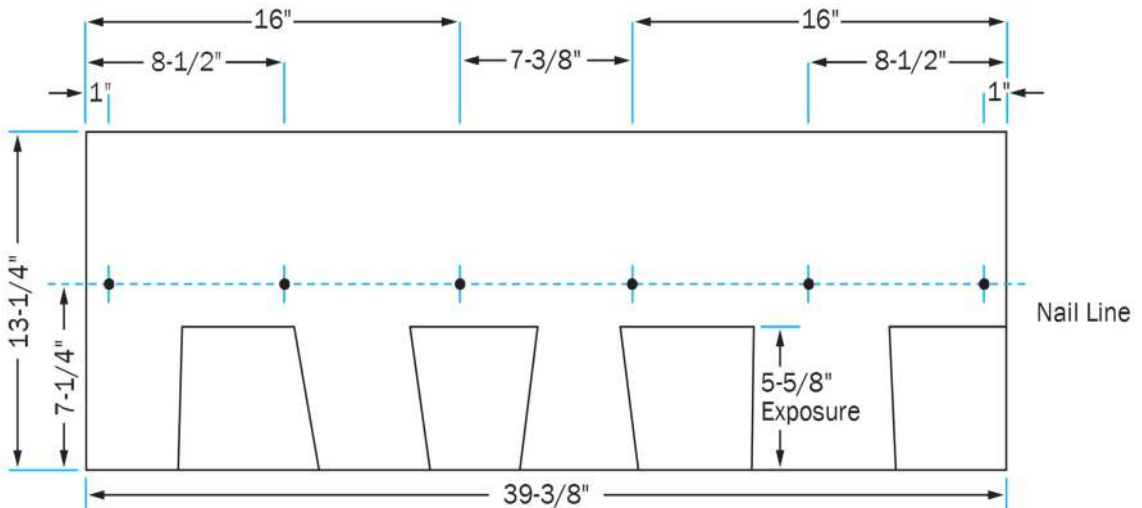

PROLINE TITAN XT SHINGLES, STORMFIGHTER FLEX 3, AND STORMFIGHTER FLEX 4

FIG. 4 ALTERNATE FASTENING PATTERN

HORIZONTAL NAIL SPACING IN ACCORDANCE WITH FIG. 1 OR FIG. 2.
VERTICAL NAIL SPACING ALLOWED ANYWHERE WITHIN NAIL ZONE.

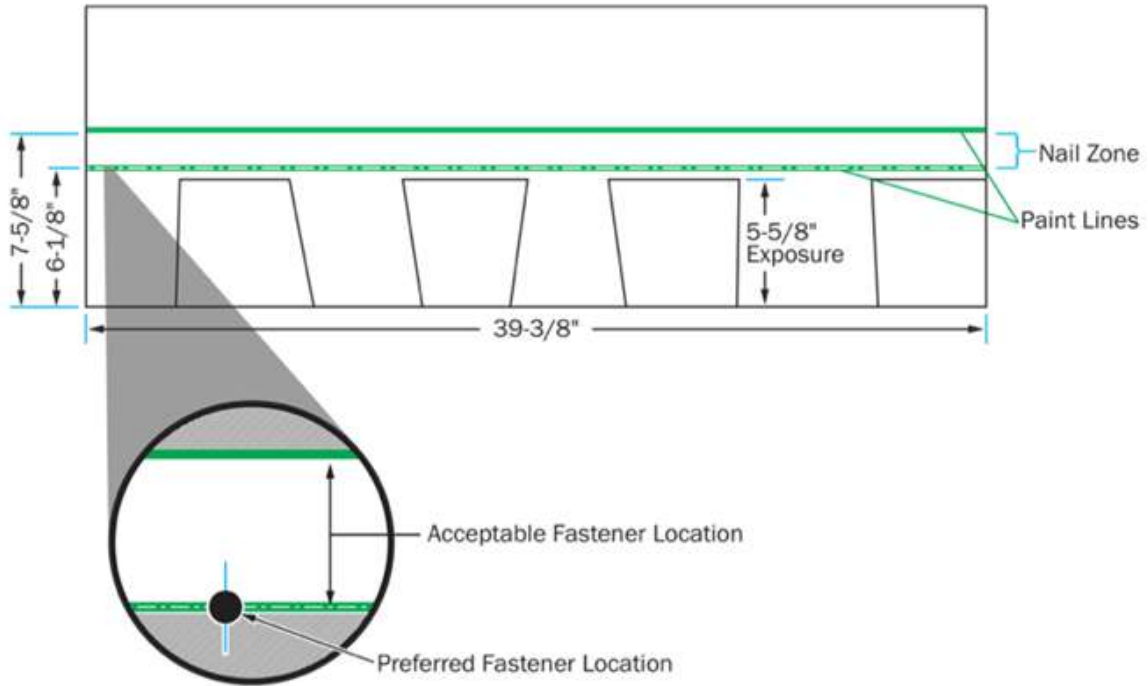

END OF THIS ACCEPTANCE