

GENERAL NOTES SECTIONS

A. CONCRETE & FOUNDATION DESIGN:

- ALL CONCRETE AND FOUNDATIONS ATTACHED TO THE HOST STRUCTURE SHALL HAVE A PRE INSPECTION.
- SOIL BEARING PRESSURE SHALL BE A MINIMUM OF 1500 PSF. THE BEARING CAPACITY OF THE SOIL TO BE VERIFIED BY A LICENSED CONTRACTOR PRIOR TO ANY POURING OF CONCRETE.
- ALL CONCRETE GRADE BEAMS AND FOOTINGS SHALL BE 3000 PSI MINIMUM.
- ALL SLABS ON GRADE SHALL BE A MINIMUM OF 4" THICK WITH FIBERMESH OR WIREMESH REINFORCING.
- ALL OVER POUR CONCRETE FILLED SUPPORTED SLABS SHALL BE 3000 PSI MIN., 2" MIN. THICKNESS WITH EPOXY.
- THE CONCRETE SHALL CONFORM TO ASTM C94 FOR THE FOLLOWING:
 - OPC (PORTLAND CEMENT TYPE 1, - ASTM C 150).
 - AGGREGATES - #6 STONE , ASTM C 33 SIZE NO. 67 LESS THAN 3/4".
 - AIR ENTRAINING +/- 1% - ASTM C 260.
 - WATER REDUCING AGENT - ASTM C 494.
 - CLEAN POTABLE WATER.
 - OTHER ADMIXTURES SHALL NOT BE PERMITTED.
- FIBERMESH REINFORCEMENT TO BE 3000 PSI (3/4" PER CUBIC YARD MIN.) AND MEET APPROPRIATE ACI AND ASTM REQUIREMENTS.
- METAL BARS SHALL CONFORM TO ASTM A 185.
- ALL REINFORCING SHALL CONFORM TO ASTM A615, BE GRADE 60 (60 KSI MIN.) DEFORMED BARS, #3 BARS MAY BE GRADE 40.
- PREPARE & PLACE CONCRETE ACCORDING TO AMERICAN CONCRETE INSTITUTE MANUAL STANDARD PRACTICE, PART 1, 2, & 3 ALONG WITH HOT WEATHER CONDITIONS RECOMMENDATIONS.
- IF UTILIZING EXISTING CONCRETE FOR FOUNDATION, CONCRETE SHALL BE A MINIMUM OF 4" IN THICKNESS, VISIBLY FREE OF ANY STRUCTURAL EXCESSIVE CRACKING, SPALLING OR OTHER DETERIORATION.
- CONTRACTOR TO FIELD VERIFY ANY EXISTING FOUNDATIONS NOTED ON SHEET S-1, DESIGN DATA: NOTE 10.
- 13. DRY PACKING/POURING IS NOT PERMITTED**

B. MASONRY:

- CONCRETE MASONRY UNITS (CMU) SHALL BE STANDARD HOLLOW UNITS AND SHALL BE 2000 PSI MINIMUM BASED ON TYPE M OR S MORTAR.
- ALL MORTAR SHALL BE OF TYPE M OR S.
- ALL GROUT SHALL BE 2000 PSI MINIMUM AND HAVE MAXIMUM COARSE AGGREGATE SIZE OF 3/8".
- PROVIDE CLEAN-OUTS FOR REINFORCED CELLS CONTAINING REINFORCEMENT WHEN GROUT POUR EXCEEDS 5'-0" IN HEIGHT.

C. ALUMINUM:

- ALL STRUCTURAL ALUMINUM SHALL CONFORM TO THE MINIMUM REQUIREMENTS OF 6005-T5 FOR ALLOY WITH A MINIMUM THICKNESS OF 0.040" FOR SUPPORTING MEMBERS.
- ALL PLATES, ANGLES, AND CHANNELS SHALL BE 6005 T5 OR T6 ALLOY.
- WHERE KICK PLATES ARE USED A MINIMUM THICKNESS OF 0.024" SHALL APPLY.
- STRUCTURAL ALUMINUM DESIGN CONFORMS TO "PART 1-A - SPECIFICATIONS FOR ALUMINUM STRUCTURES - ALLOWABLE STRESS DESIGN" OR "PART 1-B - SPECIFICATIONS FOR ALUMINUM STRUCTURES - BUILDING LOAD AND RESISTANCE FACTOR DESIGN" OF THE ALUMINUM DESIGN MANUAL PREPARED BY THE ALUMINUM ASSOCIATION, INC. WASHINGTON D.C. FLORIDA BUILDING CODE EIGHTH EDITION (2023), BUILDING (CHAPTER 16 STRUCTURAL DESIGN & CHAPTER 20 ALUMINUM).
- WHERE ALUMINUM COMES INTO CONTACT WITH STEEL, OR PRESSURE TREATED LUMBER PROVIDE DIELECTRIC SEPARATION.
- ALUMINUM SELF MATING BEAM MEMBERS SHALL BE STITCHED WITH NO LESS THAN #10 SMS 6" FROM THE ENDS AND 12" ON CENTER, IF USING #12 SPACING MAY BE 24" ON CENTER.
- VINYL AND ACRYLIC PANELS SHALL BE REMOVABLE. THEY SHALL BE IDENTIFIED WITH A DECAL ESSENTIALLY STATING "REMOVABLE PANEL SHALL BE REMOVED WHEN WIND SPEEDS EXCEED 75 MPH".

DECAL SHALL BE PLACED SO IT IS VISIBLE WHEN PANEL IS INSTALLED. VINYL AND ACRYLIC PANELS MAY NOT BE USED IN FLOOD ZONE A.

- 1"x2"x0.040" NON-STRUCTURAL MEMBERS SHALL BE ATTACHED TO HOST WITH 1/4"Ø X 1-3/4" EMBEDMENT & 24" O.C. MASONRY SCREW FOR CONCRETE & EQUIVALENT SIZE WOOD SCREW WHEN IN WOOD & #10X 1/2" EMBEDMENT SMS OR TEK SCREWS IN ALUMINUM MEMBERS TYPICAL.
- ALL 5",7", AND 9" GUTTERS SHALL BE STRUCTURAL GUTTERS

D. FASTENERS:

- ALL LAG BOLTS SHALL CONFORM TO STAINLESS STEEL TYPE 300 18-8, WITH STANDARD FLAT WASHER UNLESS MANUFACTURER GALVANIZES BOLTS SPECIFIES FOR USE WITH ACQ PRESSURE TREATED WOOD.
- HEX BOLTS HAS TO BE ASTM A 325, PLATED WITH STANDARD FLAT WASHERS AND NUTS.
- ALL CONCRETE SCREWS SHALL BE, SIMPSON, HILTI, RAWL, TAPCON, REDHEAD, DYNABOLT, PORTECT OR APPROVED EQUAL.
- ALL METAL TIES AND ASSOCIATED ACCESSORIES SHALL BE HOT DIPPED GALVANIZED.
- ALL LAG BOLTS SHALL HAVE A MINIMUM EMBEDMENT OF 8X BOLT DIAMETER INTO STRUCTURAL FRAMING (G=42 MIN.).
- LAG BOLTS AND SCREWS INTO WOOD FRAMING SHALL BE PROVIDED WITH PILOT HOLES HAVING A DIAMETER NOT GREATER THAN 70 PERCENT OF THE THREAD DIAMETER OF THE BOLT OR SCREW. ALL LAG BOLTS AND SCREWS SHALL BE INSERTED IN PILOT HOLES BY TURNING AND UNDER NO CIRCUMSTANCES BY DRIVING WITH A HAMMER.
- ALL EXPANSION ANCHORS SHALL BE DESIGNED IN ACCORDANCE WITH THE SPECIFIC MANUFACTURER'S REQUIREMENTS AND ALLOWABLE LOADS AND SHALL ONLY BE APPLIED IN CONDITIONS ACCEPTABLE TO MANUFACTURER. FASTENERS SHALL BE A MINIMUM OF SAE GRADE #5 OR BETTER ZINC PLATED.
- ALL FASTENERS CONNECTING ALUMINUM COMPONENTS OR PRESSURE TREATED LUMBER ARE STAINLESS STEEL TYPE 300 18-8, UNLESS MANUFACTURER GALVANIZED BOLTS SPECIFIES FOR USE WITH ACQ PRESSURE TREATED WOOD, OR OTHERWISE NOTED ON PLANS.
- ALL FASTENERS SHALL COMPLY WITH ASTM A153.
- ALL CONNECTORS SHALL COMPLY WITH ASTM A653 CLASS G-185.
- FOR SMS, THE MINIMUM CENTER-TO-CENTER SPACING SHALL BE 3/4" AND MINIMUM CENTER-TO-EDGE SHALL BE 1/2" UNLESS NOTED OTHER WISE.

E. REFERENCE STANDARDS: (CURRENT EDITIONS OF)

ASTM E 119
 ASTM E 1300
 ASCE 7
 ALUMINUM DESIGN MANUAL-AA ASM35, AND SPEC. FOR ALUMINUM PART 1-A, & 1-B
 ASTM C94
 ASTM C150
 ASTM C33
 ASTM C260
 ASTM C494
 ASTM A615
 ASTM A185
FLORIDA BUILDING CODE EIGHTH EDITION (2023), BUILDING
FLORIDA BUILDING CODE EIGHTH EDITION (2023), RESIDENTIAL
FLORIDA BUILDING CODE EIGHTH EDITION (2023), EXISTING HUD CODE

F. ABBREVIATIONS:

- THE FOLLOWING LIST OF ABBREVIATIONS IS NOT INTENDED TO REPRESENT ALL THOSE USED ON THESE DRAWINGS, BUT TO SUPPLEMENT THE MORE COMMON ABBREVIATIONS.
- TYP -- TYPICAL
 - SIM -- SIMILAR
 - UON -- UNLESS OTHERWISE NOTED
 - CONT -- CONTINUOUS
 - VIF -- VERIFY IN FIELD
 - SMB -- SELF MATING BEAM
 - FSM -- FLORIDA SALES AND MARKETING
 - REC -- RECEIVING CHANNEL

G. RESPONSIBILITY:

- ALL SITE WORK SHALL BE PERFORMED BY A LICENSED CONTRACTOR IN ACCORDANCE WITH APPLICABLE BUILDING CODES, LOCAL ORDINANCES, ETC.
- CONTRACTOR SHALL VERIFY ALL DIMENSIONS AND DETAILS, NOTIFYING ENGINEER OF ANY DISCREPANCIES BETWEEN DRAWINGS, FABRICATED ITEMS, OR ACTUAL FIELD CONDITIONS.
- ALL DETAILS ON THESE DRAWINGS ARE ENGINEERED BASED ON INFORMATION PROVIDED BY THE CONTRACTOR AND/OR MANUFACTURER.
- ANY DETAILS NOT SHOWN ARE TO BE ENGINEERED BY A LICENSED P.E. IN ACCORDANCE WITH STANDARD ENGINEERING PRACTICES.
- WHEN ATTACHING TO FASCIA, THE HOST STRUCTURE SHALL HAVE AT LEAST A 2"x4" FASCIA AND ROOF TRUSS SYSTEM. CONTRACTOR SHALL VERIFY THIS AND IF SMALLER, CONTRACTOR SHALL BRING STRUCTURE UP TO A 2"x4" FASCIA AND ENSURE LESS THAN A 2'-0" OVERHANG.
- FBC PLANS & ENGINEERING SERVICES INC. DOES NOT WARRANT, EITHER EXPRESSLY OR IMPLIED, THE QUALITY OF THE CONSTRUCTION, AND IS NOT RESPONSIBLE FOR THE INTERPRETATION OF DESIGNS AND END USE BY THE CLIENT/CONTRACTOR.
- CONTRACTOR TO VERIFY FEMA FLOOD ZONE OF THE PROPOSED STRUCTURE LOCATION TO ENSURE STRUCTURE IS NOT WITHIN SPECIAL FLOOD HAZARD AREAS.
- H. MISCELLANEOUS:**
 - ALUMINUM ADDITIONS ARE NOT TO BE INSTALLED ON A MANUFACTURED HOME, TRAILER HOME, OR PRE-FAB HOME. IF NO HOST BEAM IS PRESENT, A SEPARATE 4TH WALL SUPPORT SYSTEM MUST BE ENGINEERED TO ENSURE NO ADDITIONAL LOADING IS PLACED ON THE MANUFACTURED HOME.
 - IF ENCLOSURE CONTAINS A SWIMMING POOL OR SPA, THE ENCLOSURE SHALL COMPLY WITH RESIDENTIAL SWIMMING BARRIER REQUIREMENTS OF FLORIDA BUILDING CODE EIGHTH EDITION (2023), RESIDENTIAL R 4501.17 IN ITS ENTIRETY.
 - DOOR LOCATIONS MAY BE DETERMINED IN THE FIELD BY CONTRACTOR.
 - IF PAVERS ARE UNDER ALUMINUM MEMBERS THEY SHALL HAVE EPOXY ADHESIVE TO CONCRETE OR IF USING GROUT, ENSURE BONDING AGENT IS USED FIRST AND ADHERED WITH MINIMUM 3000 PSI GROUT.
 - SCREENING MATERIAL SHALL BE 18X14X0.013 OR EQUIVALENT DENSITY SCREEN MESH ONLY UNLESS NOTED ON DRAWING S-2.
 - ALL STRUCTURAL POST SHALL BE ANCHORED TO AN EXISTING/PROPOSED CONCRETE FOUNDATION FOR UPLIFT PURPOSES.
 - CONTRACTOR TO ENSURE ALL PROPOSED GUTTERS HAVE A POSITIVE FLOW.
 - EMERGENCY ESCAPE & RESCUE OPENING PER FBC R310.1 SHALL BE VERIFIED BY CONTRACTOR & BUILDING OFFICIAL.
 - ENCLOSED ADDITIONS TO MANUFACTURED HOMES SHALL NOT CHANGE THE EXIT FACILITIES FOR EGRESS PER HUD 3280.105, (A) THROUGH (A)(2)(IV), SO THAT THE DISTANCE TO EXIT DIRECTLY OUTSIDE FROM ALL BEDROOMS IS LESS THAN 35', AND, SO THAT TWO EXITS DIRECTLY OUTSIDE ARE STILL MAINTAINED. A CARPORT OR SCREEN ROOM SHALL BE CONSIDERED AS OUTSIDE. NON-HABITABLE SUNROOMS OR HABITABLE LIVING SPACE MAY BE ADDED WHERE AN EXIT DOOR WAS LOCATED AS LONG AS A NEW EXIT DOOR IS ADDED AND MEETS THE REQUIREMENTS OF HUD 3280.105.
 - AWS CERTIFIED WELDER REQUIRED FOR ALL WELDING.

PATIO COVER

DESIGN DATA: (SITE SPECIFIC DESIGN INFORMATION)

- ULTIMATE DESIGN WIND SPEED Vult, (3 SECOND GUST): 125 MPH
 NOMINAL DESIGN WIND SPEED Vasd: 97 MPH
- RISK CATEGORY: 1
- WIND EXPOSURE: B
- WIND LOADS:
 - SCREEN ROOF: N/A
 - SCREEN WALLS (WINDWARD): N/A
 - SCREEN WALLS (LEEWARD): N/A
 - SOLID ROOF: 23 PSF
- FACTOR APPLIED TO SCREEN WIND LOADS FOR 18/14: 0.88
 FACTOR APPLIED TO SCREEN WIND LOADS FOR 20/20: 1.0
 MESH TYPE AND LOCATION SHOWN ON S-2
 FACTORS FOR OTHER SCREEN MESHES TO BE DETERMINED BY THE ENGINEER
- FACTOR APPLIED TO SCREEN WIND LOADS FOR ALLOWABLE STRESS DESIGN: 0.6
- LIVE LOAD:
 - 300 lb. VERTICAL DOWNLOAD ON PRIMARY SCREEN ENCLOSURE MEMBERS.
 - 200 lb. VERTICAL DOWNLOAD ON SCREEN ENCLOSURE PURLINS.
- SCREEN ROOF TYPE: N/A
- NON-SCREEN ROOF TYPE: ELITE EPS COMPOSITE PANEL ROOF, FLORIDA PRODUCT APPROVAL, FL 7561-R7.
- PROPOSED FOUNDATION (SEE S-2 FOR SIZE AND LOCATION) SHALL BE ADEQUATE TO RESIST THE UPLOADS FOR THE PROPOSED STRUCTURE

ALUMINUM STRUCTURAL MEMBERS

HOLLOW SECTIONS

2 X 2:-----2" X 2" X 0.044"
 2 X 3:-----2" X 3" X 0.050"
 2 X 4:-----2" X 4" X 0.050"
 2 X 5:-----2" X 5" X 0.050"
 3 X 3:-----3" X 3" X 0.125"

OPEN BACK SECTIONS

1 X 2:-----1" X 2" X 0.040"
 1 X 3:-----1" X 3" X 0.045"

SNAP SECTIONS

2 X 2 SMS:-----2" X 2" X 0.045"
 2 X 3 SMS:-----2" X 3" X 0.072"
 2 X 4 SMS:-----2" X 4" X 0.045"
 3 X 3 SMS:-----3" X 3" X 0.090"

SELF MATING (SMB)

2 X 4 SMB:-----2" X 4" X 0.044" X 0.100"
 2 X 5 SMB:-----2" X 5" X 0.050" X 0.118"
 2 X 6 SMB:-----2" X 6" X 0.050" X 0.120"
 2 X 7 SMB:-----2" X 7" X 0.057" X 0.120"
 2 X 8 SMB:-----2" X 8" X 0.072" X 0.224"
 2 X 9 SMB:-----2" X 9" X 0.072" X 0.224"
 2 X 10 SMB:-----2" X 10" X 0.092" X 0.374"

TUBE SECTIONS

2 X 2:-----2" X 2" X 0.090"

ST E

PROFESSIONAL ENGINEER SEAL			
P. E. OF RECORD	DAVID W. SMITH	THOMAS L. HANSON	ERIK STUART
	FL 53608	FL 38654	FL 77605
FBC PLANS & ENGINEERING SERVICES, INC.	ADDRESS: 5344 9th Street Zephyrhills, FL 33542		
	PHONE: (813)838-0735 FAX: 1-(866)824-7894 E-MAIL: erb@fbcplans.com WEBSITE: www.fbcplans.com C.O.A.: #29054		
			
PROJECT WHITCOMB 167 SW MOSSY OAK WAY, LAKE CITY, FLORIDA, 32024	CONTRACTOR TOPLINE ALUMINUM 456 SW SUNNY ACRES GLEN LAKE CITY FL ZIP32024		
JOB NUMBER: 26_0318_109	DRAW DATE: 03/18/2026		
REVISION 1:			
REVISION 2:			
REVISION 3:			
NOTES			
<h1>S-1</h1>			

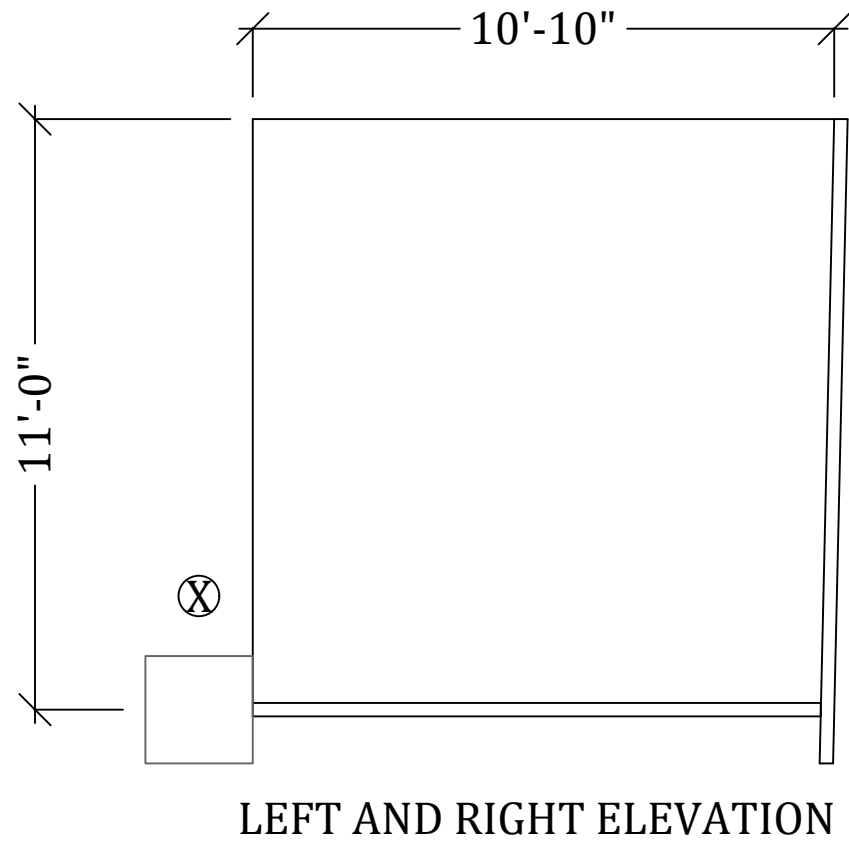

⊗ = PROPOSED 2'X2'X2' ISOLATED FOOTING TOTAL (2)

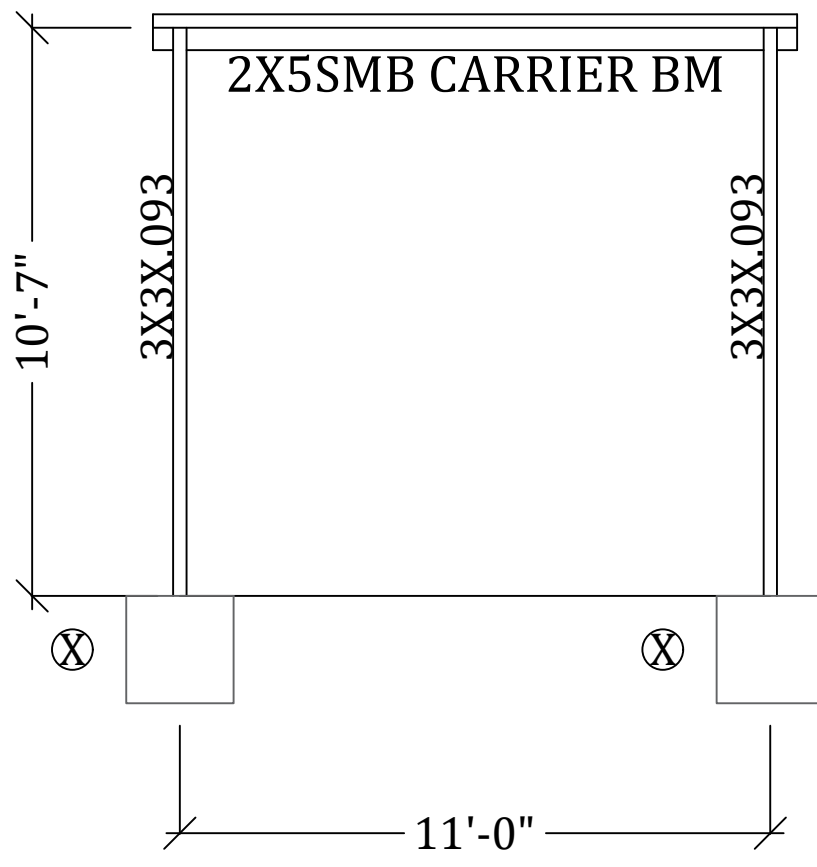
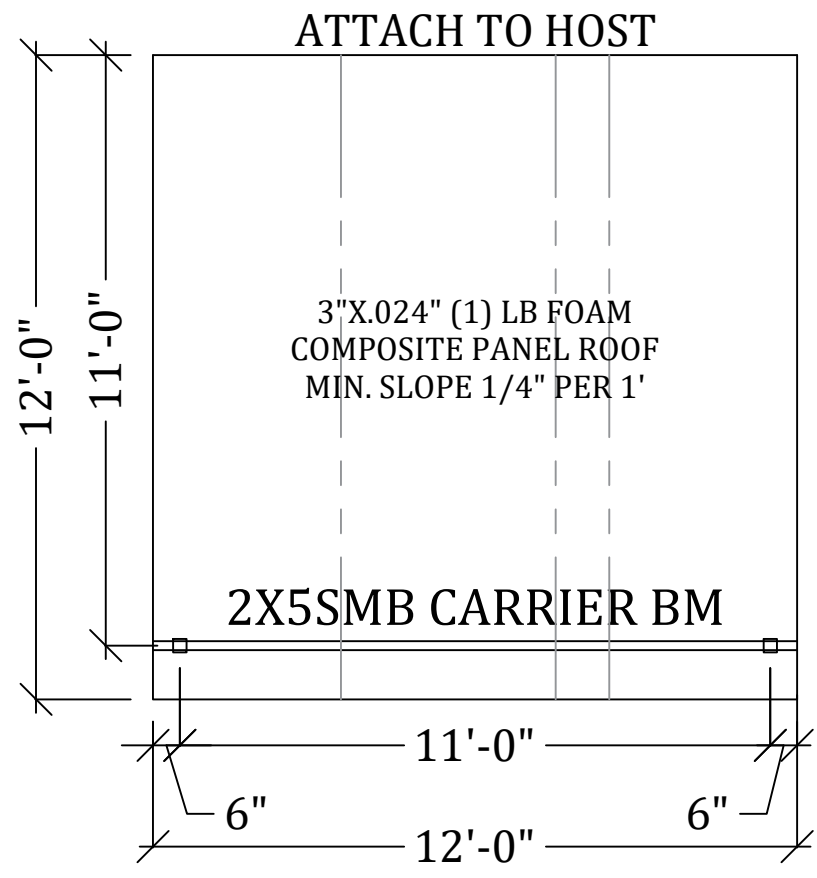

JOB NUMBER: 26_0318_109		PROJECT WHITCOMB 167 SW MOSSY OAK WAY, LAKE CITY, FLORIDA, 32024		FBC PLANS & ENGINEERING SERVICES, INC.		P. E. OF RECORD	
DRAW DATE: 03/18/2026		CONTRACTOR TOPLINE ALUMINUM 456 SW SUNNY ACRES GLEN LAKE CITY FL 32132024		ADDRESS: 5344 9th Street Zephyrhills, FL 33542		DAVID W. SMITH FL 53608	
REVISION 1:				PHONE: (813)838-0735		THOMAS L. HANSON FL 38654	
REVISION 2:				FAX: 1-(866)824-7894		IAN J. FOSTER FL 93654	
REVISION 3:				E-MAIL: erb@bcplans.com		JOEL FALARDEAU FL 70667	
				WEBSITE: www.bcplans.com		ERIK STUART FL 77605	
				C.O.A.: #29054			
DRAWING				S-2			

PROFESSIONAL ENGINEER SEAL



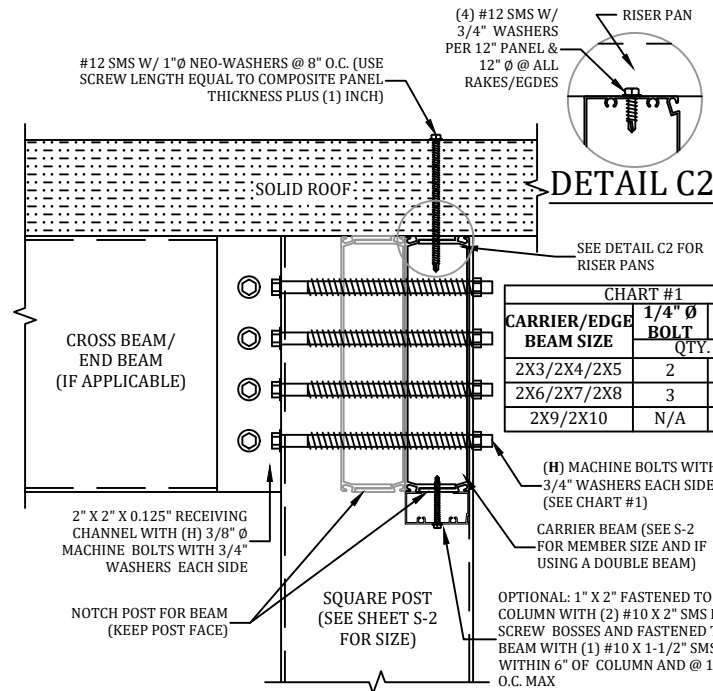

DETAIL C2

CHART #1

CARRIER/EDGE BEAM SIZE	1/4" Ø BOLT QTY. (H)	3/8" Ø BOLT QTY. (H)
2X3/2X4/2X5	2	N/A
2X6/2X7/2X8	3	2
2X9/2X10	N/A	3

NOTES:
1. EDGE BEAM MAY BE NOTCHED IN CENTER OR FRONT OF UPRIGHT WHEN APPLICABLE

S ROOF PANEL TO EDGE/INTERMEDIATE BEAM W/ SQUARE POST CONNECTION DETAIL
SCALE: N.T.S.

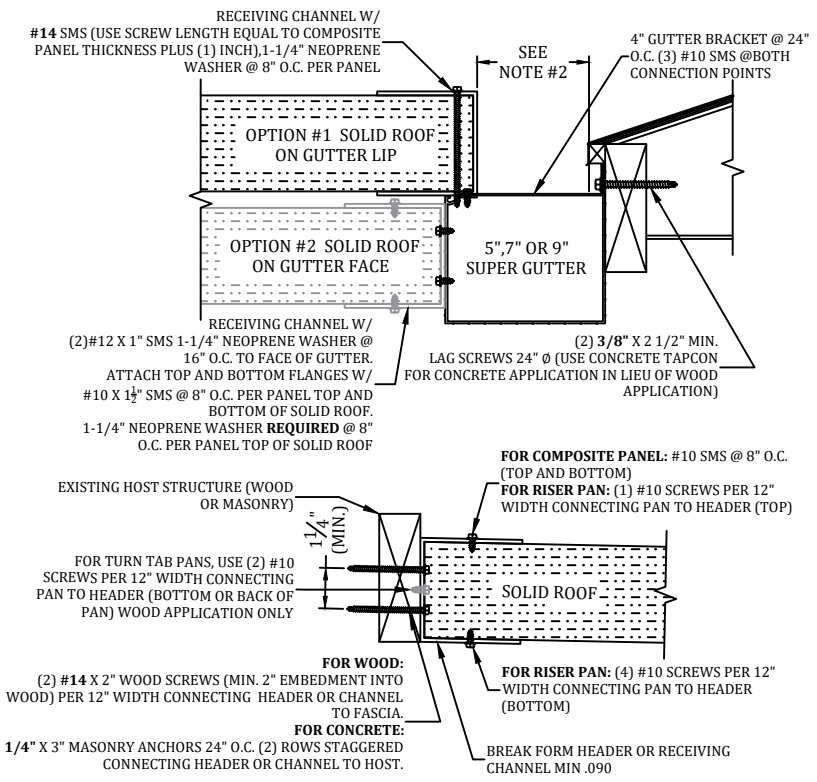

S1 SOLID ROOF TO HOST DETAIL
SCALE: N.T.S.

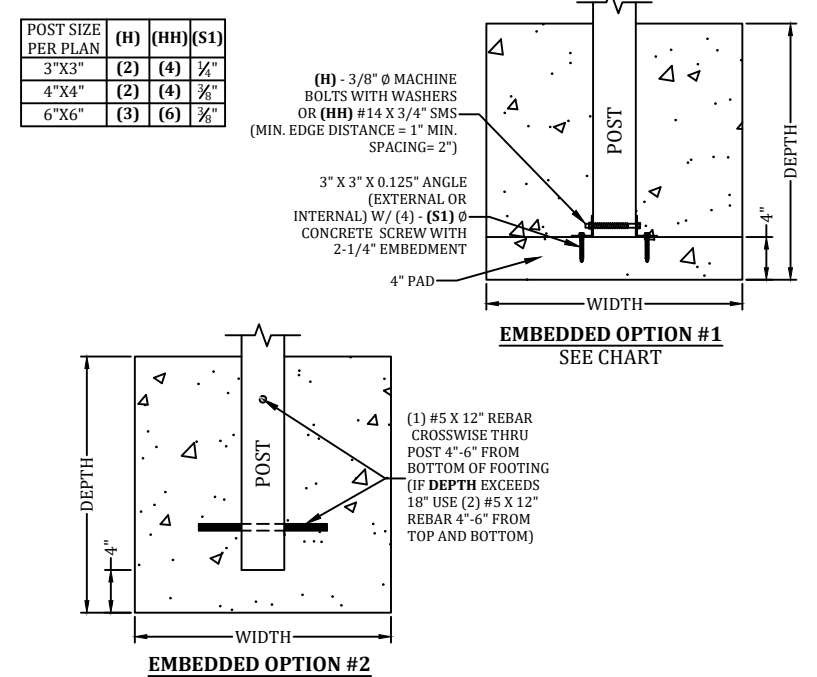

NOTES FOR ALL FOUNDATION TYPES:
1. THE FOUNDATIONS SHOWN ARE BASED ON A MINIMUM SOIL BEARING PRESSURE OF 1,500 PSF. WHEN FOUNDATIONS EXCEED 12" IN DEPTH, THE BEARING CAPACITY OF THE SOIL TO BE VERIFIED BY A LICENSED CONTRACTOR PRIOR TO ANY POURING OF CONCRETE.
2. THE SLAB/FOUNDATION MUST BE CLEARED OF ALL DEBRIS, AND COMPACTED PRIOR TO POURING OF ANY CONCRETE.
3. CONCRETE MEET THE SPECIFICATIONS IN THE S-1 NOTES PAGE.
4. SEE SHEET S-2 FOR ISO FOOTING SIZES

K1 ISOLATED FOOTING DETAIL
SCALE: N.T.S.

PROFESSIONAL ENGINEER SEAL

P.E. OF RECORD	FL 53608	FL 38654	FL 93654	FL 70667	FL 77605
DAVID W. SMITH	THOMAS L. HANSON	IAN J. FOSTER	JOEL FALARDEAU	ERIK STUART	

FBC PLANS & ENGINEERING SERVICES, INC.

ADDRESS: 5344 9th Street Zephyrhills, FL 33542
 PHONE: (813)838-0735
 FAX: 1-(866)824-7894
 E-MAIL: erb@fbcplans.com
 WEBSITE: www.fbcplans.com
 C.O.A.: #29054

PROJECT
WHITCOMB
167 SW MOSSY OAK WAY,
LAKE CITY, FLORIDA, 32024

CONTRACTOR
TOPLINE ALUMINUM
456 SW SUNNY ACRES GLEN
LAKE CITY FL ZIP 32024

JOB NUMBER:
26_0318_109

DRAW DATE: 03/18/2026

REVISION 1:
REVISION 2:
REVISION 3: