



Lumber design values are in accordance with ANSI/TPI 1 section 6.3
 These truss designs rely on lumber values established by others.

RE: 2525538 - AMIRA BLDRS - THOMAS RES.

MiTek USA, Inc.
 6904 Parke East Blvd.
 Tampa, FL 33610-4115

Site Information:

Customer Info: Amira Bldrs. Project Name: Thomas Res. Model: Custom
 Lot/Block: N/A Subdivision: N/A
 Address: 4221 CR 18, TBD
 City: Columbia Cty State: FL

Name Address and License # of Structural Engineer of Record, If there is one, for the building.

Name: License #:
 Address: State:
 City: State:

General Truss Engineering Criteria & Design Loads (Individual Truss Design Drawings Show Special Loading Conditions):

Design Code: FBC2017/TPI2014 Design Program: MiTek 20/20 8.2
 Wind Code: ASCE 7-10 Wind Speed: 130 mph
 Roof Load: 37.0 psf Floor Load: N/A psf

This package includes 46 individual, Truss Design Drawings and 0 Additional Drawings.
 With my seal affixed to this sheet, I hereby certify that I am the Truss Design Engineer and this index sheet conforms to 61G15-31.003, section 5 of the Florida Board of Professional Engineers Rules.

No.	Seal#	Truss Name	Date	No.	Seal#	Truss Name	Date
1	T21805026	CJ01	11/5/20	23	T21805048	T10	11/5/20
2	T21805027	CJ03	11/5/20	24	T21805049	T11	11/5/20
3	T21805028	CJ05	11/5/20	25	T21805050	T12	11/5/20
4	T21805029	EJ01	11/5/20	26	T21805051	T12G	11/5/20
5	T21805030	EJ02	11/5/20	27	T21805052	T13	11/5/20
6	T21805031	HJ08	11/5/20	28	T21805053	T14	11/5/20
7	T21805032	PB01	11/5/20	29	T21805054	T14G	11/5/20
8	T21805033	PB01G	11/5/20	30	T21805055	T15	11/5/20
9	T21805034	T01	11/5/20	31	T21805056	T16	11/5/20
10	T21805035	T01G	11/5/20	32	T21805057	T17	11/5/20
11	T21805036	T02	11/5/20	33	T21805058	T17G	11/5/20
12	T21805037	T02G	11/5/20	34	T21805059	V01	11/5/20
13	T21805038	T03	11/5/20	35	T21805060	V02	11/5/20
14	T21805039	T04	11/5/20	36	T21805061	V03	11/5/20
15	T21805040	T04G	11/5/20	37	T21805062	V04	11/5/20
16	T21805041	T05	11/5/20	38	T21805063	V05	11/5/20
17	T21805042	T06	11/5/20	39	T21805064	V06	11/5/20
18	T21805043	T06G	11/5/20	40	T21805065	V07	11/5/20
19	T21805044	T07	11/5/20	41	T21805066	V08	11/5/20
20	T21805045	T07G	11/5/20	42	T21805067	V09	11/5/20
21	T21805046	T08	11/5/20	43	T21805068	V10	11/5/20
22	T21805047	T09	11/5/20	44	T21805069	V11	11/5/20

The truss drawing(s) referenced above have been prepared by MiTek USA, Inc. under my direct supervision based on the parameters provided by Builders FirstSource-Jacksonville.

Truss Design Engineer's Name: Velez, Joaquin
 My license renewal date for the state of Florida is February 28, 2021.

IMPORTANT NOTE: The seal on these truss component designs is a certification that the engineer named is licensed in the jurisdiction(s) identified and that the designs comply with ANSI/TPI 1. These designs are based upon parameters shown (e.g., loads, supports, dimensions, shapes and design codes), which were given to MiTek or TRENCO. Any project specific information included is for MiTek's or TRENCO's customers file reference purpose only, and was not taken into account in the preparation of these designs. MiTek or TRENCO has not independently verified the applicability of the design parameters or the designs for any particular building. Before use, the building designer should verify applicability of design parameters and properly incorporate these designs into the overall building design per ANSI/TPI 1, Chapter 2.

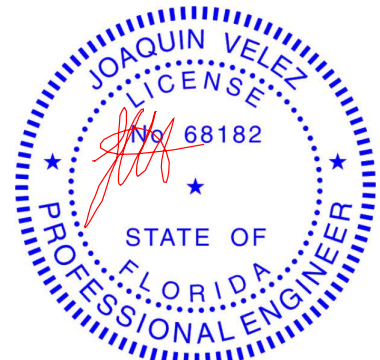

Joaquin Velez PE No.68182
 MiTek USA, Inc. FL Cert 6634
 6904 Parke East Blvd. Tampa FL 33610
 Date:

November 5, 2020



RE: 2525538 - AMIRA BLDRS - THOMAS RES.

MiTek USA, Inc.
6904 Parke East Blvd.
Tampa, FL 33610-4115

Site Information:

Customer Info: Amira Bldrs. Project Name: Thomas Res. Model: Custom
Lot/Block: N/A Subdivision: N/A
Address: 4221 CR 18, TBD
City: Columbia Cty State: FL

No.	Seal#	Truss Name	Date
45	T21805070	V12	11/5/20
46	T21805071	V13	11/5/20

Job 2525538	Truss CJ01	Truss Type JACK-OPEN	Qty 4	Ply 1	AMIRA BLDRS - THOMAS RES. T21805026
----------------	---------------	-------------------------	----------	----------	--

Builders FirstSource (Jacksonville, FL), Jacksonville, FL - 32244,

8.240 s Mar 9 2020 MiTek Industries, Inc. Thu Nov 5 09:18:32 2020 Page 1

ID:7WKr8toudn35dxwKwBAfQtytHta-5QPyZ_9tgSgbq_as3ncN1Jp8cGrVjzMdwujwlyMH4r

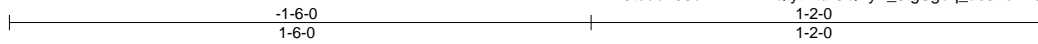

Scale = 1:5.9

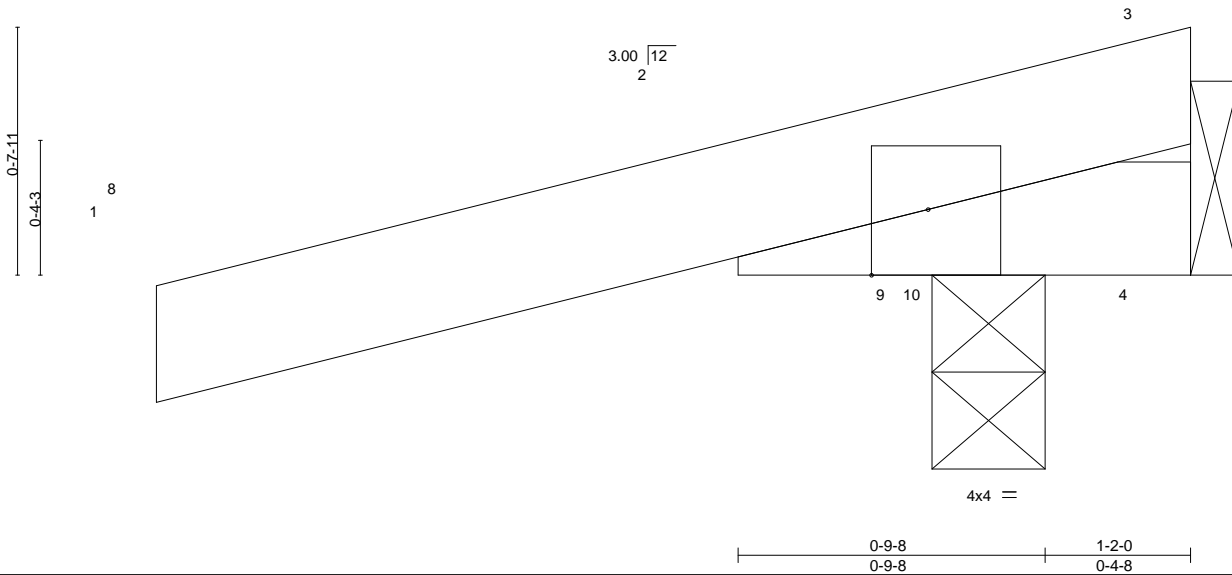

Plate Offsets (X,Y)--	[2:0-1-12,Edge]						
LOADING (psf)	SPACING-	2-0-0	CSI.	DEFL.	in (loc)	l/defl	L/d
TCLL 20.0	Plate Grip DOL 1.25		TC 0.33	Vert(LL) -0.02	2	>666	240
TCDL 7.0	Lumber DOL 1.25		BC 0.41	Vert(CT) -0.03	2	>464	180
BCLL 0.0 *	Rep Stress Incr YES		WB 0.00	Horz(CT) -0.00	2	n/a	n/a
BCDL 10.0	Code FBC2017/TPI2014		Matrix-MP				
							PLATES MT20
							GRIP 244/190
							Weight: 6 lb FT = 20%

LUMBER-
TOP CHORD 2x4 SP No.2
BOT CHORD 2x4 SP No.2

BRACING-
TOP CHORD Structural wood sheathing directly applied or 1-2-0 oc purlins.
BOT CHORD Rigid ceiling directly applied or 10-0-0 oc bracing.

REACTIONS. (size) 4=Mechanical, 2=0-3-8
Max Horz 2=25(LC 8)
Max Uplift 4=164(LC 1), 2=187(LC 8)
Max Grav 4=134(LC 8), 2=366(LC 1)

FORCES. (lb) - Max. Comp./Max. Ten. - All forces 250 (lb) or less except when shown.

NOTES-

- 1) Wind: ASCE 7-10; Vult=130mph (3-second gust) Vasd=101mph; TC DL=4.2psf; BCDL=3.0psf; h=20ft; Cat. II; Exp B; Encl., GCpi=0.18; MWFRS (envelope) gable end zone and C-C Exterior(2) zone; cantilever left exposed; porch left and right exposed; C-C for members and forces & MWFRS for reactions shown; Lumber DOL=1.60 plate grip DOL=1.60
- 2) This truss has been designed for a 10.0 psf bottom chord live load nonconcurrent with any other live loads.
- 3) * This truss has been designed for a live load of 20.0psf on the bottom chord in all areas where a rectangle 3-6-0 tall by 2-0-0 wide will fit between the bottom chord and any other members.
- 4) Refer to girder(s) for truss to truss connections.
- 5) Provide mechanical connection (by others) of truss to bearing plate capable of withstanding 100 lb uplift at joint(s) except (jt=lb) 4=164, 2=187.

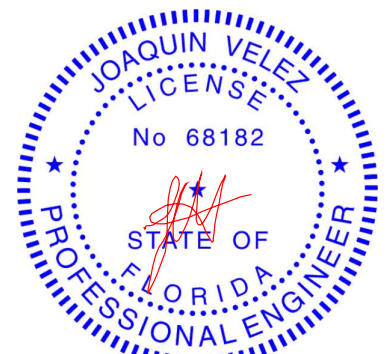

Joaquin Velez PE No.68182
MiTek USA, Inc. FL Cert 6634
6904 Parke East Blvd. Tampa FL 33610
Date:

November 5, 2020

WARNING - Verify design parameters and READ NOTES ON THIS AND INCLUDED MITEK REFERENCE PAGE MII-7473 rev. 5/19/2020 BEFORE USE.

Design valid for use only with MiTek® connectors. This design is based only upon parameters shown, and is for an individual building component, not a truss system. Before use, the building designer must verify the applicability of design parameters and properly incorporate this design into the overall building design. Bracing indicated is to prevent buckling of individual truss web and/or chord members only. Additional temporary and permanent bracing is always required for stability and to prevent collapse with possible personal injury and property damage. For general guidance regarding the fabrication, storage, delivery, erection and bracing of trusses and truss systems, see **ANSI/TPI1 Quality Criteria, DSB-89 and BCSI Building Component Safety Information** available from Truss Plate Institute, 2670 Crain Highway, Suite 203 Waldorf, MD 20601



6904 Parke East Blvd.
Tampa, FL 36610

Job 2525538	Truss CJ03	Truss Type Jack-Open	Qty 4	Ply 1	AMIRA BLDRS - THOMAS RES. Job Reference (optional)	T21805027
----------------	---------------	-------------------------	----------	----------	---	-----------

Builders FirstSource (Jacksonville, FL), Jacksonville, FL - 32244,

8.240 s Mar 9 2020 MiTek Industries, Inc. Thu Nov 5 09:18:33 2020 Page 1

ID:7WKr8toudn35dxwKwBAfQtytHta-ZczKnKAVRmoRR893cV8caXLMHGF1SmCVsaeGSkyMH4q

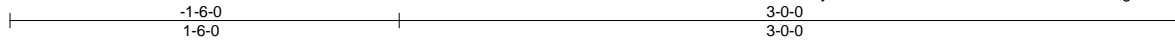

Scale = 1:8.9

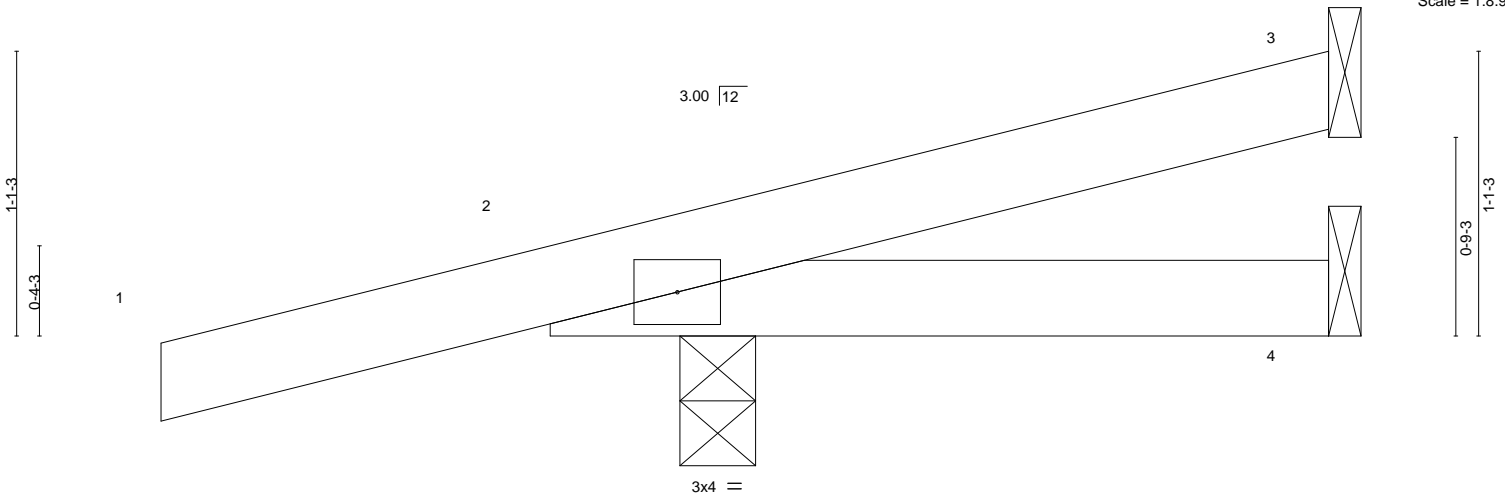

LOADING (psf)	SPACING-	CSL	DEFL.	in (loc)	l/defl	L/d	PLATES	GRIP
TCLL 20.0	2-0-0	TC 0.14	Vert(LL)	-0.00	5	>999	MT20	244/190
TCDL 7.0	Plate Grip DOL 1.25	BC 0.13	Vert(CT)	-0.00	5	>999		
BCLL 0.0 *	Lumber DOL 1.25	WB 0.00	Horz(CT)	-0.00	3	n/a		
BCDL 10.0	Rep Stress Incr YES	Matrix-MP						
	Code FBC2017/TPI2014						Weight: 11 lb	FT = 20%

LUMBER-

TOP CHORD 2x4 SP No.2
BOT CHORD 2x4 SP No.2

BRACING-

TOP CHORD Structural wood sheathing directly applied or 3-0-0 oc purlins.
BOT CHORD Rigid ceiling directly applied or 10-0-0 oc bracing.

REACTIONS.

(size) 3=Mechanical, 4=Mechanical, 2=0-3-8
Max Horz 2=48(LC 8)
Max Uplift 3=21(LC 12), 4=12(LC 9), 2=169(LC 8)
Max Grav 3=35(LC 1), 4=36(LC 3), 2=254(LC 1)

FORCES. (lb) - Max. Comp./Max. Ten. - All forces 250 (lb) or less except when shown.

NOTES-

- 1) Wind: ASCE 7-10; Vult=130mph (3-second gust) Vasd=101mph; TCDL=4.2psf; BCDL=3.0psf; h=20ft; Cat. II; Exp B; Encl., GCpi=0.18; MWFRS (envelope) gable end zone and C-C Exterior(2) zone; cantilever left exposed; porch left and right exposed; C-C for members and forces & MWFRS for reactions shown; Lumber DOL=1.60 plate grip DOL=1.60
- 2) This truss has been designed for a 10.0 psf bottom chord live load nonconcurrent with any other live loads.
- 3) * This truss has been designed for a live load of 20.0psf on the bottom chord in all areas where a rectangle 3-6-0 tall by 2-0-0 wide will fit between the bottom chord and any other members.
- 4) Refer to girder(s) for truss to truss connections.
- 5) Provide mechanical connection (by others) of truss to bearing plate capable of withstanding 100 lb uplift at joint(s) 3, 4 except (jt=lb) 2=169.

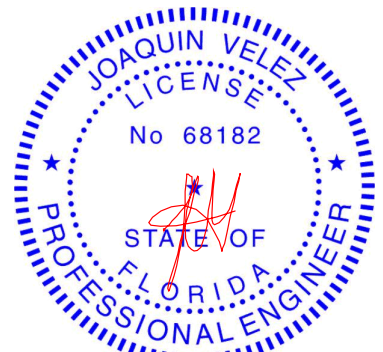

Joaquin Velez PE No.68182
MiTek USA, Inc. FL Cert 6634
6904 Parke East Blvd. Tampa FL 33610
Date:

November 5, 2020

WARNING - Verify design parameters and READ NOTES ON THIS AND INCLUDED MITEK REFERENCE PAGE MII-7473 rev. 5/19/2020 BEFORE USE.

Design valid for use only with MiTek® connectors. This design is based only upon parameters shown, and is for an individual building component, not a truss system. Before use, the building designer must verify the applicability of design parameters and properly incorporate this design into the overall building design. Bracing indicated is to prevent buckling of individual truss web and/or chord members only. Additional temporary and permanent bracing is always required for stability and to prevent collapse with possible personal injury and property damage. For general guidance regarding the fabrication, storage, delivery, erection and bracing of trusses and truss systems, see **ANSI/TPI1 Quality Criteria, DSB-89 and BCSI Building Component Safety Information** available from Truss Plate Institute, 2670 Crain Highway, Suite 203 Waldorf, MD 20601



6904 Parke East Blvd.
Tampa, FL 33610

Job 2525538	Truss CJ05	Truss Type Jack-Open	Qty 4	Ply 1	AMIRA BLDRS - THOMAS RES. Job Reference (optional)	T21805028
----------------	---------------	-------------------------	----------	----------	---	-----------

Builders FirstSource (Jacksonville, FL),

Jacksonville, FL - 32244,

8.240 s Mar 9 2020 MiTek Industries, Inc. Thu Nov 5 09:18:34 2020 Page 1

ID:7Wkr8toudn35dxwKwBAfQtytHta-1oXi_gB7C4wI3kFACfr6kuWD3bNBDSf4ENq_AyMH4p

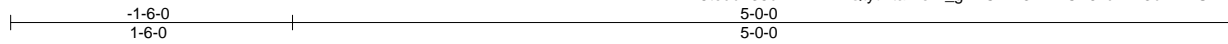

Scale = 1:12.3

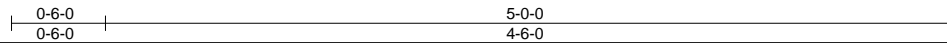
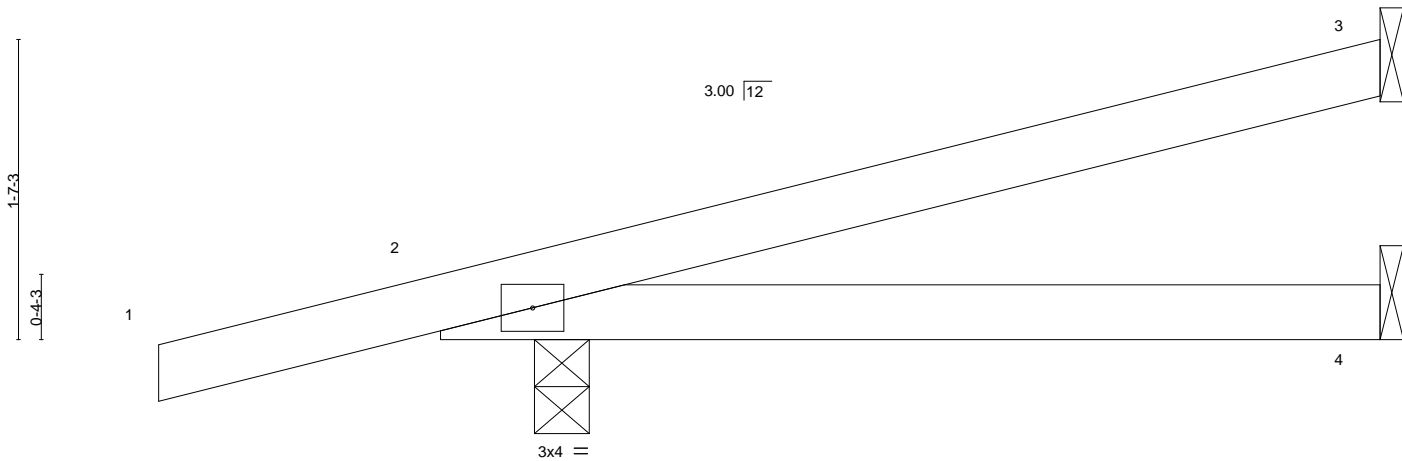

LOADING (psf)	SPACING-	2-0-0	CSI.	DEFL.	in (loc)	l/defl	L/d	PLATES	GRIP
TCLL 20.0	Plate Grip DOL	1.25	TC 0.19	Vert(LL)	0.04	4-9	>999	MT20	244/190
TCDL 7.0	Lumber DOL	1.25	BC 0.19	Vert(CT)	-0.03	4-9	>999		
BCLL 0.0 *	Rep Stress Incr	YES	WB 0.00	Horz(CT)	-0.00	3	n/a		
BCDL 10.0	Code FBC2017/TPI2014		Matrix-MP						
								Weight: 18 lb	FT = 20%

LUMBER-

TOP CHORD 2x4 SP No.2
BOT CHORD 2x4 SP No.2

BRACING-

TOP CHORD Structural wood sheathing directly applied or 5-0-0 oc purlins.
BOT CHORD Rigid ceiling directly applied or 10-0-0 oc bracing.

REACTIONS.

(size) 3=Mechanical, 4=Mechanical, 2=0-3-8
Max Horz 2=67(LC 8)
Max Uplift 3=-56(LC 8), 4=-27(LC 9), 2=-193(LC 8)
Max Grav 3=95(LC 1), 4=76(LC 3), 2=307(LC 1)

FORCES. (lb) - Max. Comp./Max. Ten. - All forces 250 (lb) or less except when shown.

NOTES-

- 1) Wind: ASCE 7-10; Vult=130mph (3-second gust) Vasd=101mph; TCCL=4.2psf; BCCL=3.0psf; h=20ft; Cat. II; Exp B; Encl., GCpi=0.18; MWFRS (envelope) gable end zone and C-C Exterior(2) zone; cantilever left exposed; porch left and right exposed; C-C for members and forces & MWFRS for reactions shown; Lumber DOL=1.60 plate grip DOL=1.60
- 2) This truss has been designed for a 10.0 psf bottom chord live load nonconcurrent with any other live loads.
- 3) * This truss has been designed for a live load of 20.0psf on the bottom chord in all areas where a rectangle 3-6-0 tall by 2-0-0 wide will fit between the bottom chord and any other members.
- 4) Refer to girder(s) for truss to truss connections.
- 5) Provide mechanical connection (by others) of truss to bearing plate capable of withstanding 100 lb uplift at joint(s) 3, 4 except (jt=lb) 2=193.

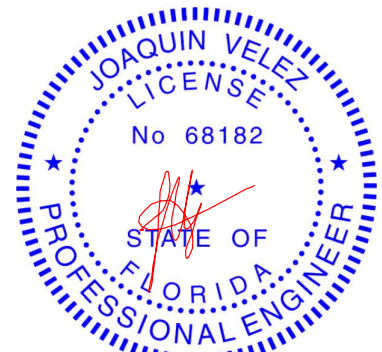

Joaquin Velez PE No.68182
MiTek USA, Inc. FL Cert 6634
6904 Parke East Blvd. Tampa FL 33610
Date:

November 5, 2020

WARNING - Verify design parameters and READ NOTES ON THIS AND INCLUDED MITEK REFERENCE PAGE MII-7473 rev. 5/19/2020 BEFORE USE.

Design valid for use only with MiTek® connectors. This design is based only upon parameters shown, and is for an individual building component, not a truss system. Before use, the building designer must verify the applicability of design parameters and properly incorporate this design into the overall building design. Bracing indicated is to prevent buckling of individual truss web and/or chord members only. Additional temporary and permanent bracing is always required for stability and to prevent collapse with possible personal injury and property damage. For general guidance regarding the fabrication, storage, delivery, erection and bracing of trusses and truss systems, see **ANSI/TPI1 Quality Criteria, DSB-89 and BCSI Building Component Safety Information** available from Truss Plate Institute, 2670 Crain Highway, Suite 203 Waldorf, MD 20601



6904 Parke East Blvd.
Tampa, FL 33610

Job 2525538	Truss EJ01	Truss Type Jack-Partial	Qty 14	Ply 1	AMIRA BLDRS - THOMAS RES. T21805029
----------------	---------------	----------------------------	-----------	----------	--

Builders FirstSource (Jacksonville, FL), Jacksonville, FL - 32244,

8.240 s Mar 9 2020 MiTek Industries, Inc. Thu Nov 5 09:18:34 2020 Page 1
ID:7WKr8toudn35dxwKwBAfQtytHta-1oXi_gB7C4wl3IkFACfr6kuVV3bSBCXf4ENq_AyMH4p

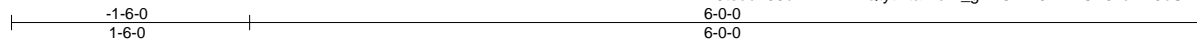

Scale = 1:14.5

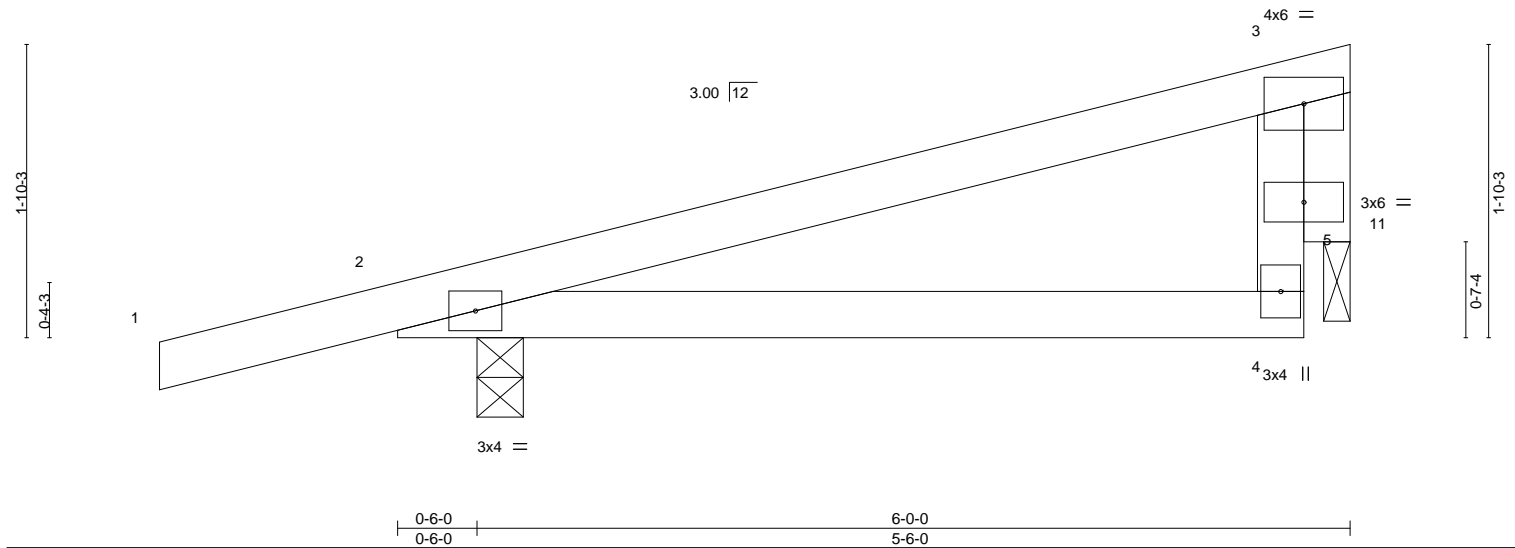

LOADING (psf)	SPACING-	2-0-0	CSI.	DEFL.	in (loc)	l/defl	L/d	PLATES	GRIP
TCLL 20.0	Plate Grip DOL	1.25	TC 0.30	Vert(LL)	0.03	4-10	>999	MT20	244/190
TCDL 7.0	Lumber DOL	1.25	BC 0.18	Vert(CT)	-0.02	4-10	>999		
BCLL 0.0 *	Rep Stress Incr	YES	WB 0.12	Horz(CT)	-0.00	11	n/a		
BCDL 10.0	Code FBC2017/TPI2014		Matrix-MR						
								Weight: 23 lb	FT = 20%

LUMBER-
TOP CHORD 2x4 SP No.2
BOT CHORD 2x4 SP No.2
WEBS 2x4 SP No.3
OTHERS 2x4 SP No.2

BRACING-
TOP CHORD Structural wood sheathing directly applied or 6-0-0 oc purlins, except end verticals.
BOT CHORD Rigid ceiling directly applied or 10-0-0 oc bracing.

REACTIONS. (size) 2=0-3-8, 11=0-2-0
Max Horz 2=73(LC 8)
Max Uplift 2=210(LC 8), 11=92(LC 8)
Max Grav 2=338(LC 1), 11=155(LC 1)

FORCES. (lb) - Max. Comp./Max. Ten. - All forces 250 (lb) or less except when shown.

NOTES-

- Wind: ASCE 7-10; Vult=130mph (3-second gust) Vasd=101mph; TCCL=4.2psf; BCCL=3.0psf; h=20ft; Cat. II; Exp B; Encl., GCpi=0.18; MWFRS (envelope) gable end zone and C-C Exterior(2) zone; cantilever left exposed; porch left and right exposed; C-C for members and forces & MWFRS for reactions shown; Lumber DOL=1.60 plate grip DOL=1.60
- This truss has been designed for a 10.0 psf bottom chord live load nonconcurrent with any other live loads.
- * This truss has been designed for a live load of 20.0psf on the bottom chord in all areas where a rectangle 3-6-0 tall by 2-0-0 wide will fit between the bottom chord and any other members.
- Bearing at joint(s) 11 considers parallel to grain value using ANSI/TPI 1 angle to grain formula. Building designer should verify capacity of bearing surface.
- Provide mechanical connection (by others) of truss to bearing plate at joint(s) 11.
- Provide mechanical connection (by others) of truss to bearing plate capable of withstanding 100 lb uplift at joint(s) 11 except (jt=lb) 2=210.

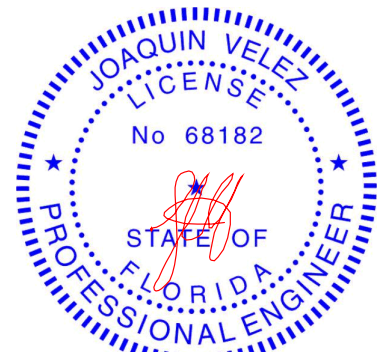

Joaquin Velez PE No.68182
MiTek USA, Inc. FL Cert 6634
6904 Parke East Blvd. Tampa FL 33610
Date:

November 5, 2020

WARNING - Verify design parameters and READ NOTES ON THIS AND INCLUDED MITEK REFERENCE PAGE MII-7473 rev. 5/19/2020 BEFORE USE.

Design valid for use only with MiTek® connectors. This design is based only upon parameters shown, and is for an individual building component, not a truss system. Before use, the building designer must verify the applicability of design parameters and properly incorporate this design into the overall building design. Bracing indicated is to prevent buckling of individual truss web and/or chord members only. Additional temporary and permanent bracing is always required for stability and to prevent collapse with possible personal injury and property damage. For general guidance regarding the fabrication, storage, delivery, erection and bracing of trusses and truss systems, see **ANSI/TPI1 Quality Criteria, DSB-89 and BCSI Building Component Safety Information** available from Truss Plate Institute, 2670 Crain Highway, Suite 203 Waldorf, MD 20601



6904 Parke East Blvd.
Tampa, FL 33610

Job 2525538	Truss EJ02	Truss Type Jack-Open	Qty 6	Ply 1	AMIRA BLDRS - THOMAS RES. Job Reference (optional)	T21805030
----------------	---------------	-------------------------	----------	----------	---	-----------

Builders FirstSource (Jacksonville, FL), Jacksonville, FL - 32244,

8.240 s Mar 9 2020 MiTek Industries, Inc. Thu Nov 5 09:18:35 2020 Page 1
ID:7WKr8toudn35dxwKwBAfQtytHta-V?54C0CmyN39hRJrkvA4fyRinTxVwgToJu7NXcyMH4o

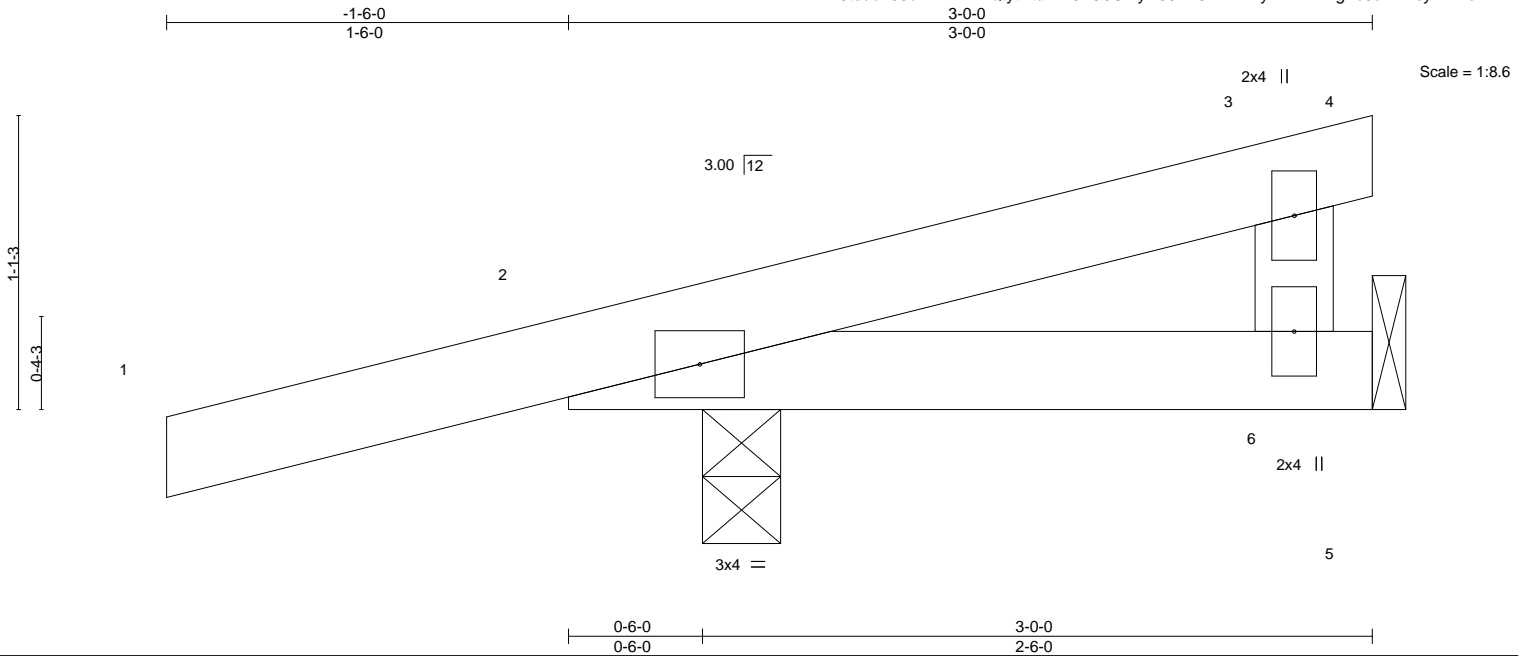

LOADING (psf)	SPACING-	CSI.	DEFL.	in (loc)	l/defl	L/d	PLATES	GRIP
TCLL 20.0	2-0-0	TC 0.14	Vert(LL)	-0.00	7	>999	MT20	244/190
TCDL 7.0	Plate Grip DOL 1.25	BC 0.13	Vert(CT)	-0.00	7	>999		
BCLL 0.0 *	Lumber DOL 1.25	WB 0.02	Horz(CT)	0.00	2	n/a		
BCDL 10.0	Rep Stress Incr YES	Matrix-MP						
	Code FBC2017/TPI2014						Weight: 12 lb	FT = 20%

LUMBER-
 TOP CHORD 2x4 SP No.2
 BOT CHORD 2x4 SP No.2
 WEBS 2x4 SP No.3

BRACING-
 TOP CHORD Structural wood sheathing directly applied or 3-0-0 oc purlins.
 BOT CHORD Rigid ceiling directly applied or 10-0-0 oc bracing.

REACTIONS. (size) 6=Mechanical, 2=0-3-8
 Max Horz 2=48(LC 8)
 Max Uplift 6=-26(LC 9), 2=-167(LC 8)
 Max Grav 6=61(LC 3), 2=249(LC 1)

FORCES. (lb) - Max. Comp./Max. Ten. - All forces 250 (lb) or less except when shown.

NOTES-

- 1) Wind: ASCE 7-10; Vult=130mph (3-second gust) Vasd=101mph; TCDL=4.2psf; BCDL=3.0psf; h=20ft; Cat. II; Exp B; Encl., GCpi=0.18; MWFRS (envelope) gable end zone and C-C Exterior(2) zone; cantilever left exposed; porch left and right exposed; C-C for members and forces & MWFRS for reactions shown; Lumber DOL=1.60 plate grip DOL=1.60
- 2) This truss has been designed for a 10.0 psf bottom chord live load nonconcurrent with any other live loads.
- 3) * This truss has been designed for a live load of 20.0psf on the bottom chord in all areas where a rectangle 3-6-0 tall by 2-0-0 wide will fit between the bottom chord and any other members.
- 4) Refer to girder(s) for truss to truss connections.
- 5) Provide mechanical connection (by others) of truss to bearing plate capable of withstanding 100 lb uplift at joint(s) 6 except (jt=lb) 2=167.

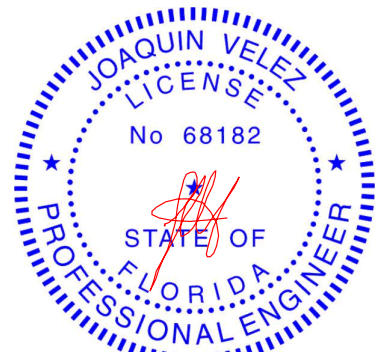

Joaquin Velez PE No.68182
 MiTek USA, Inc. FL Cert 6634
 6904 Parke East Blvd. Tampa FL 33610
 Date:

November 5, 2020

WARNING - Verify design parameters and READ NOTES ON THIS AND INCLUDED MITEK REFERENCE PAGE MII-7473 rev. 5/19/2020 BEFORE USE.

Design valid for use only with MiTek® connectors. This design is based only upon parameters shown, and is for an individual building component, not a truss system. Before use, the building designer must verify the applicability of design parameters and properly incorporate this design into the overall building design. Bracing indicated is to prevent buckling of individual truss web and/or chord members only. Additional temporary and permanent bracing is always required for stability and to prevent collapse with possible personal injury and property damage. For general guidance regarding the fabrication, storage, delivery, erection and bracing of trusses and truss systems, see **ANSI/TPI1 Quality Criteria, DSB-89 and BCSI Building Component Safety Information** available from Truss Plate Institute, 2670 Crain Highway, Suite 203 Waldorf, MD 20601



6904 Parke East Blvd.
 Tampa, FL 33610

Job 2525538	Truss HJ08	Truss Type Roof Special Girder	Qty 2	Ply 1	AMIRA BLDRS - THOMAS RES. Job Reference (optional)	T21805031
----------------	---------------	-----------------------------------	----------	----------	---	-----------

Builders FirstSource (Jacksonville, FL), Jacksonville, FL - 32244,

8.240 s Mar 9 2020 MiTek Industries, Inc. Thu Nov 5 09:18:36 2020 Page 2
ID:7WKr8toudn35dxwKwBAfQtytHta-zBfTPMC0jhB0lbueIdhJC9zp7iDVf6oyYYsx33yMH4n

LOAD CASE(S) Standard

Concentrated Loads (lb)

Vert: 12=134(F=67, B=67) 15=-70(F=-35, B=-35) 16=11(F=5, B=5) 17=-47(F=-24, B=-24)

 **WARNING - Verify design parameters and READ NOTES ON THIS AND INCLUDED MITEK REFERENCE PAGE MII-7473 rev. 5/19/2020 BEFORE USE.**

Design valid for use only with MiTek® connectors. This design is based only upon parameters shown, and is for an individual building component, not a truss system. Before use, the building designer must verify the applicability of design parameters and properly incorporate this design into the overall building design. Bracing indicated is to prevent buckling of individual truss web and/or chord members only. Additional temporary and permanent bracing is always required for stability and to prevent collapse with possible personal injury and property damage. For general guidance regarding the fabrication, storage, delivery, erection and bracing of trusses and truss systems, see **ANSI/TPI1 Quality Criteria, DSB-89 and BCSI Building Component Safety Information** available from Truss Plate Institute, 2670 Crain Highway, Suite 203 Waldorf, MD 20601



6904 Parke East Blvd.
Tampa, FL 36610

Job 2525538	Truss PB01	Truss Type Piggyback	Qty 16	Ply 1	AMIRA BLDRS - THOMAS RES. Job Reference (optional)	T21805032
----------------	---------------	-------------------------	-----------	----------	---	-----------

Builders FirstSource (Jacksonville, FL),

Jacksonville, FL - 32244,

8.240 s Mar 9 2020 MiTek Industries, Inc. Thu Nov 5 09:18:37 2020 Page 1

ID:7WKr8toudn35dxwKwBAfQtytHta-RNDrdiDOU?JtwlTqrKCYkNW13Hd2OaV5mCcUbVyMH4m

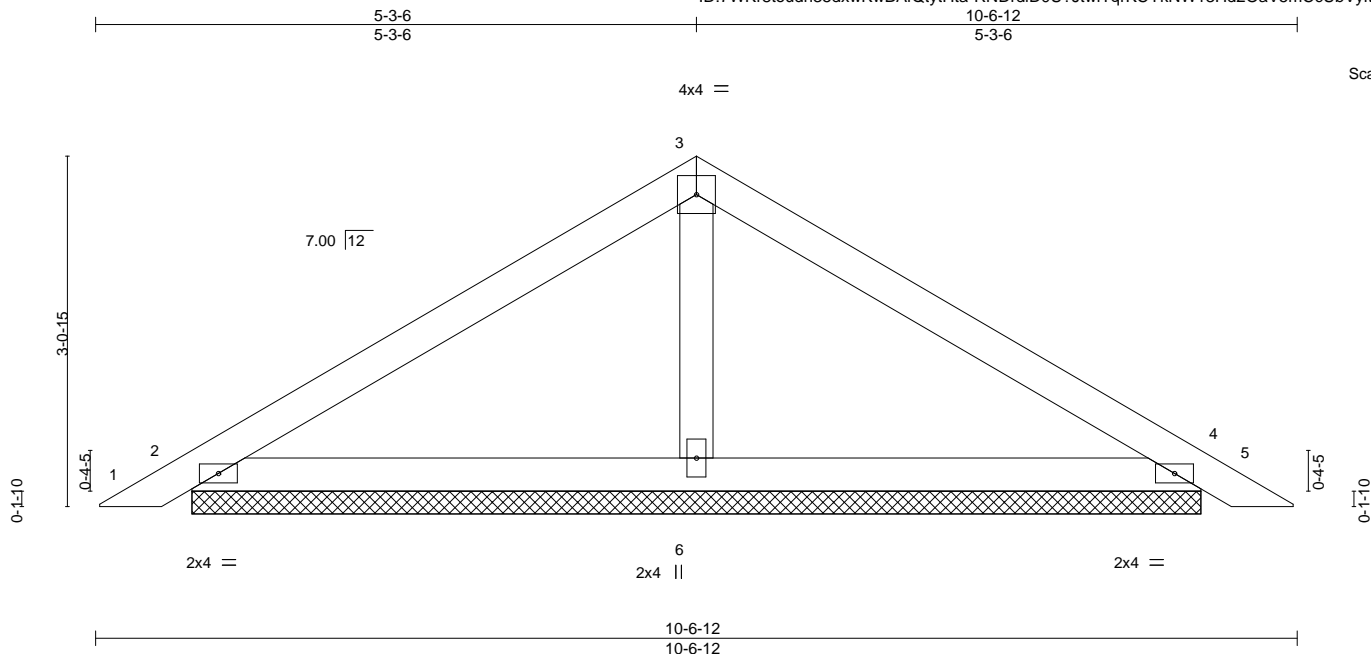

Scale = 1:20.3

LOADING (psf)	SPACING-	CSI.	DEFL.	in (loc)	l/defl	L/d	PLATES	GRIP
TCLL 20.0	2-0-0	TC 0.22	Vert(LL)	0.01	5	n/r	MT20	244/190
TCDL 7.0	Plate Grip DOL 1.25	BC 0.19	Vert(CT)	0.01	5	n/r		
BCLL 0.0 *	Lumber DOL 1.25	WB 0.05	Horz(CT)	0.00	4	n/a		
BCDL 10.0	Rep Stress Incr YES	Matrix-S						
	Code FBC2017/TPI2014						Weight: 35 lb	FT = 20%

LUMBER-
 TOP CHORD 2x4 SP No.2
 BOT CHORD 2x4 SP No.2
 OTHERS 2x4 SP No.3

BRACING-
 TOP CHORD Structural wood sheathing directly applied or 6-0-0 oc purlins.
 BOT CHORD Rigid ceiling directly applied or 10-0-0 oc bracing.

REACTIONS. (size) 2=8-10-7, 4=8-10-7, 6=8-10-7
 Max Horz 2=72(LC 11)
 Max Uplift 2=65(LC 12), 4=75(LC 13), 6=61(LC 12)
 Max Grav 2=185(LC 1), 4=185(LC 1), 6=344(LC 1)

FORCES. (lb) - Max. Comp./Max. Ten. - All forces 250 (lb) or less except when shown.

NOTES-

- Unbalanced roof live loads have been considered for this design.
- Wind: ASCE 7-10; Vult=130mph (3-second gust) Vasd=101mph; TCCL=4.2psf; BCDL=3.0psf; h=20ft; Cat. II; Exp B; Encl., GCpi=0.18; MWFRS (envelope) gable end zone and C-C Exterior(2) zone; C-C for members and forces & MWFRS for reactions shown; Lumber DOL=1.60 plate grip DOL=1.60
- Gable requires continuous bottom chord bearing.
- This truss has been designed for a 10.0 psf bottom chord live load nonconcurrent with any other live loads.
- * This truss has been designed for a live load of 20.0psf on the bottom chord in all areas where a rectangle 3-6-0 tall by 2-0-0 wide will fit between the bottom chord and any other members.
- Provide mechanical connection (by others) of truss to bearing plate capable of withstanding 100 lb uplift at joint(s) 2, 4, 6.
- See Standard Industry Piggyback Truss Connection Detail for Connection to base truss as applicable, or consult qualified building designer.

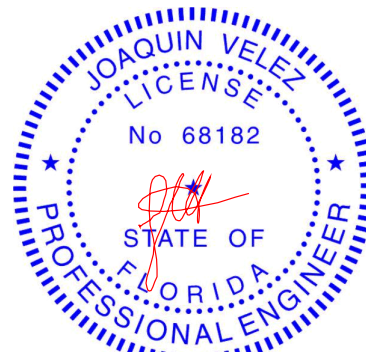

Joaquin Velez PE No.68182
 MiTek USA, Inc. FL Cert 6634
 6904 Parke East Blvd. Tampa FL 33610
 Date:

November 5, 2020

WARNING - Verify design parameters and READ NOTES ON THIS AND INCLUDED MITEK REFERENCE PAGE MII-7473 rev. 5/19/2020 BEFORE USE.

Design valid for use only with MiTek® connectors. This design is based only upon parameters shown, and is for an individual building component, not a truss system. Before use, the building designer must verify the applicability of design parameters and properly incorporate this design into the overall building design. Bracing indicated is to prevent buckling of individual truss web and/or chord members only. Additional temporary and permanent bracing is always required for stability and to prevent collapse with possible personal injury and property damage. For general guidance regarding fabrication, storage, delivery, erection and bracing of trusses and truss systems, see **ANSI/TPI1 Quality Criteria, DSB-89 and BCSI Building Component Safety Information** available from Truss Plate Institute, 2670 Crain Highway, Suite 203 Waldorf, MD 20601



6904 Parke East Blvd.
 Tampa, FL 33610

Job 2525538	Truss PB01G	Truss Type GABLE	Qty 2	Ply 1	AMIRA BLDRS - THOMAS RES. Job Reference (optional)	T21805033
----------------	----------------	---------------------	----------	----------	---	-----------

Builders FirstSource (Jacksonville, FL),

Jacksonville, FL - 32244,

8.240 s Mar 9 2020 MiTek Industries, Inc. Thu Nov 5 09:18:38 2020 Page 1

ID:7WKr8toudn35dxwKwBAfQtytHta-wanDq2EeFIRkYv20P2jnHa2Fah_n71?E?sL17xyMH4l

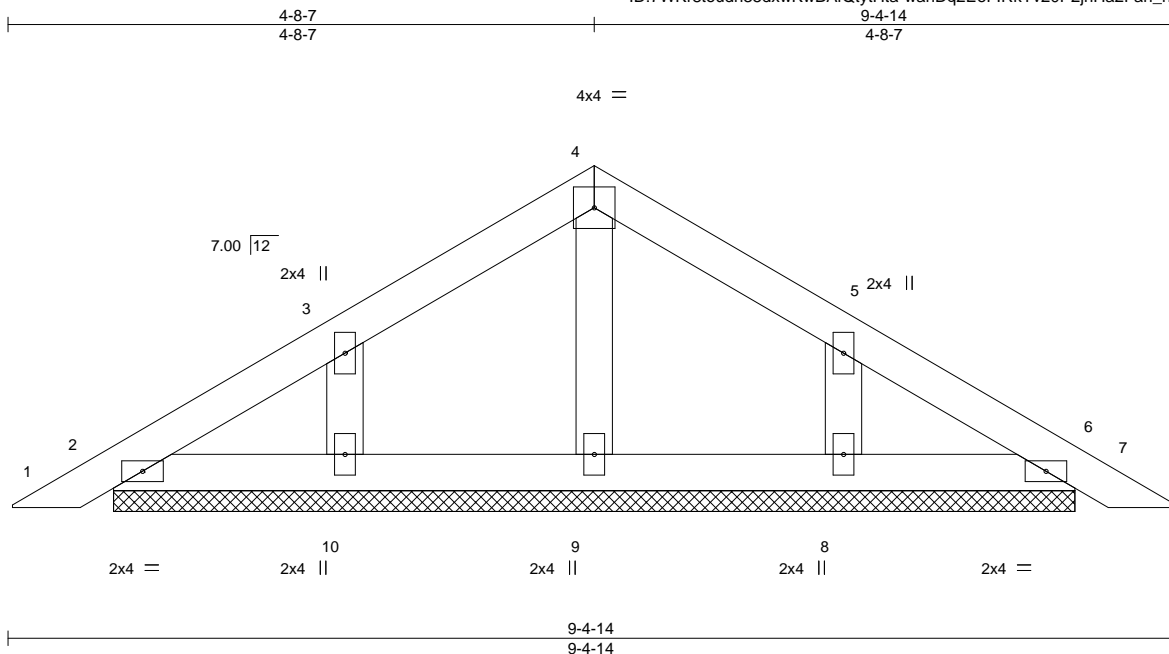

Scale = 1:18.5

LOADING (psf)	SPACING-	CSI.	DEFL.	PLATES	GRIP
TCLL 20.0	2-0-0	TC 0.04	in (loc) l/defl L/d	MT20	244/190
TCDL 7.0	Plate Grip DOL 1.25	BC 0.03	Vert(LL) 0.00 6 n/r 120		
BCLL 0.0 *	Lumber DOL 1.25	WB 0.03	Vert(CT) 0.00 6 n/r 120		
BCDL 10.0	Rep Stress Incr YES	Matrix-S	Horz(CT) 0.00 6 n/a n/a		
	Code FBC2017/TPI2014			Weight: 33 lb	FT = 20%

LUMBER-
 TOP CHORD 2x4 SP No.2
 BOT CHORD 2x4 SP No.2
 OTHERS 2x4 SP No.3

BRACING-
 TOP CHORD Structural wood sheathing directly applied or 6-0-0 oc purlins.
 BOT CHORD Rigid ceiling directly applied or 10-0-0 oc bracing.

REACTIONS. All bearings 7-8-9.
 (lb) - Max Horz 2=63(LC 11)
 Max Uplift All uplift 100 lb or less at joint(s) 2, 6, 10, 8
 Max Grav All reactions 250 lb or less at joint(s) 2, 6, 9, 10, 8

FORCES. (lb) - Max. Comp./Max. Ten. - All forces 250 (lb) or less except when shown.

NOTES-

- Unbalanced roof live loads have been considered for this design.
- Wind: ASCE 7-10; Vult=130mph (3-second gust) Vasd=101mph; TCCL=4.2psf; BCDL=3.0psf; h=20ft; Cat. II; Exp B; Encl., GCpi=0.18; MWFRS (envelope) gable end zone and C-C Exterior(2) zone; C-C for members and forces & MWFRS for reactions shown; Lumber DOL=1.60 plate grip DOL=1.60
- Truss designed for wind loads in the plane of the truss only. For studs exposed to wind (normal to the face), see Standard Industry Gable End Details as applicable, or consult qualified building designer as per ANSI/TPI 1.
- Gable requires continuous bottom chord bearing.
- Gable studs spaced at 2-0-0 oc.
- This truss has been designed for a 10.0 psf bottom chord live load nonconcurrent with any other live loads.
- * This truss has been designed for a live load of 20.0psf on the bottom chord in all areas where a rectangle 3-6-0 tall by 2-0-0 wide will fit between the bottom chord and any other members.
- Provide mechanical connection (by others) of truss to bearing plate capable of withstanding 100 lb uplift at joint(s) 2, 6, 10, 8.
- See Standard Industry Piggyback Truss Connection Detail for Connection to base truss as applicable, or consult qualified building designer.

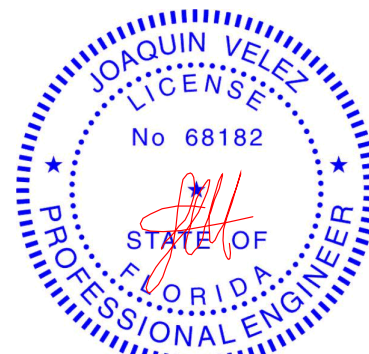

Joaquin Velez PE No.68182
 MiTek USA, Inc. FL Cert 6634
 6904 Parke East Blvd. Tampa FL 33610
 Date:

November 5, 2020

WARNING - Verify design parameters and READ NOTES ON THIS AND INCLUDED MITEK REFERENCE PAGE MII-7473 rev. 5/19/2020 BEFORE USE.

Design valid for use only with MiTek® connectors. This design is based only upon parameters shown, and is for an individual building component, not a truss system. Before use, the building designer must verify the applicability of design parameters and properly incorporate this design into the overall building design. Bracing indicated is to prevent buckling of individual truss web and/or chord members only. Additional temporary and permanent bracing is always required for stability and to prevent collapse with possible personal injury and property damage. For general guidance regarding the fabrication, storage, delivery, erection and bracing of trusses and truss systems, see **ANSI/TPI1 Quality Criteria, DSB-89 and BCSI Building Component Safety Information** available from Truss Plate Institute, 2670 Crain Highway, Suite 203 Waldorf, MD 20601



6904 Parke East Blvd.
 Tampa, FL 33610

Job 2525538	Truss T01	Truss Type Common	Qty 3	Ply 1	AMIRA BLDRS - THOMAS RES. T21805034
----------------	--------------	----------------------	----------	----------	--

Builders FirstSource (Jacksonville, FL), Jacksonville, FL - 32244,

8.240 s Mar 9 2020 MiTek Industries, Inc. Thu Nov 5 09:18:40 2020 Page 1

ID:7WKr8toudn35dxwKwBAfQtytHta-syuzFkGunwhSnDBPXtmFM?8UfUaLbqWXT9q8CqyMH4j

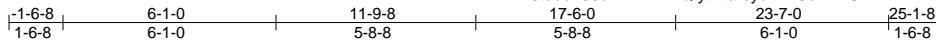

4x6 ||

Scale = 1:65.8

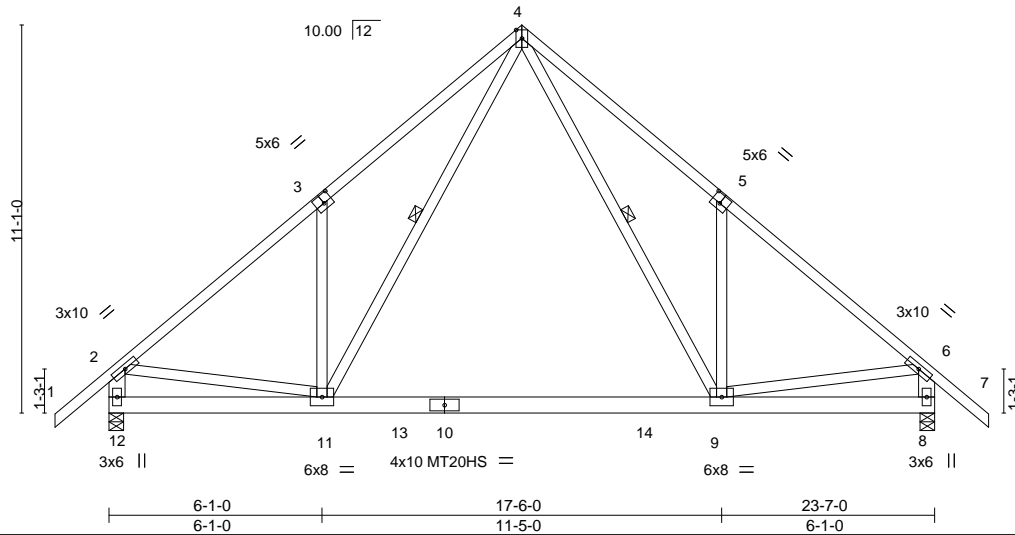

Plate Offsets (X,Y)-- [3:0-3:0,0-3:0], [5:0-3:0,0-3:0]

LOADING (psf)	SPACING-	2-0-0	CSI.	DEFL.	in (loc)	l/defl	L/d	PLATES	GRIP
TCLL 20.0	Plate Grip DOL	1.25	TC 0.45	Vert(LL)	-0.23 9-11	>999	240	MT20	244/190
TCDL 7.0	Lumber DOL	1.25	BC 0.41	Vert(CT)	-0.43 9-11	>648	180	MT20HS	187/143
BCLL 0.0 *	Rep Stress Incr	NO	WB 0.41	Horz(CT)	0.01 8	n/a	n/a		
BCDL 10.0	Code FBC2017/TPI2014		Matrix-MS						
								Weight: 179 lb	FT = 20%

LUMBER-

TOP CHORD 2x4 SP No.2
 BOT CHORD 2x6 SP M 26
 WEBS 2x4 SP No.3 *Except*
 2-12,6-8: 2x6 SP No.2

BRACING-

TOP CHORD Structural wood sheathing directly applied or 4-0-10 oc purlins, except end verticals.
 BOT CHORD Rigid ceiling directly applied or 6-0-0 oc bracing.
 WEBS 1 Row at midpt 4-9, 4-11

REACTIONS.

(size) 12=0-5-0, 8=0-5-0
 Max Horz 12=-312(LC 10)
 Max Uplift 12=-347(LC 12), 8=-347(LC 13)
 Max Grav 12=1340(LC 19), 8=1296(LC 20)

FORCES.

(lb) - Max. Comp./Max. Ten. - All forces 250 (lb) or less except when shown.
 TOP CHORD 2-3=-1636/458, 3-4=-1700/689, 4-5=-1630/689, 5-6=-1657/458, 2-12=-1441/475, 6-8=-1391/475
 BOT CHORD 11-12=-296/318, 9-11=-93/844
 WEBS 4-9=-460/1066, 5-9=-386/348, 4-11=-460/1116, 3-11=-386/349, 2-11=-182/1201, 6-9=-186/1271

NOTES-

- Unbalanced roof live loads have been considered for this design.
- Wind: ASCE 7-10; Vult=130mph (3-second gust) Vasd=101mph; TCCL=4.2psf; BCDL=3.0psf; h=20ft; Cat. II; Exp B; Encl., GCpi=0.18; MWFRS (envelope) gable end zone and C-C Exterior(2) zone; end vertical left and right exposed; C-C for members and forces & MWFRS for reactions shown; Lumber DOL=1.60 plate grip DOL=1.60
- All plates are MT20 plates unless otherwise indicated.
- This truss has been designed for a 10.0 psf bottom chord live load nonconcurrent with any other live loads.
- * This truss has been designed for a live load of 20.0psf on the bottom chord in all areas where a rectangle 3-6-0 tall by 2-0-0 wide will fit between the bottom chord and any other members, with BCDL = 10.0psf.
- Provide mechanical connection (by others) of truss to bearing plate capable of withstanding 100 lb uplift at joint(s) except (jt=lb) 12=347, 8=347.
- In the LOAD CASE(S) section, loads applied to the face of the truss are noted as front (F) or back (B).

LOAD CASE(S) Standard

1) Dead + Roof Live (balanced): Lumber Increase=1.25, Plate Increase=1.25
 Uniform Loads (plf)
 Vert: 1-2=-54, 2-4=-54, 4-6=-54, 6-7=-54, 11-12=-20, 9-11=-80(F=-60), 8-9=-20

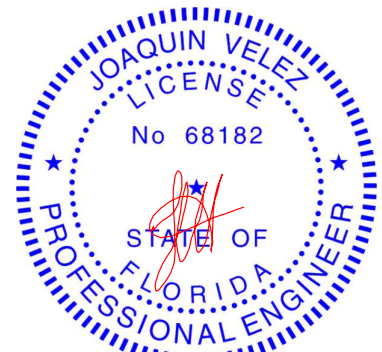

Joaquin Velez PE No.68182
 MiTek USA, Inc. FL Cert 6634
 6904 Parke East Blvd. Tampa FL 33610
 Date:

November 5, 2020

WARNING - Verify design parameters and READ NOTES ON THIS AND INCLUDED MITEK REFERENCE PAGE MII-7473 rev. 5/19/2020 BEFORE USE.

Design valid for use only with MiTek® connectors. This design is based only upon parameters shown, and is for an individual building component, not a truss system. Before use, the building designer must verify the applicability of design parameters and properly incorporate this design into the overall building design. Bracing indicated is to prevent buckling of individual truss web and/or chord members only. Additional temporary and permanent bracing is always required for stability and to prevent collapse with possible personal injury and property damage. For general guidance regarding the fabrication, storage, delivery, erection and bracing of trusses and truss systems, see **ANSI/TPI1 Quality Criteria, DSB-89 and BCSI Building Component Safety Information** available from Truss Plate Institute, 2670 Crain Highway, Suite 203 Waldorf, MD 20601



6904 Parke East Blvd.
 Tampa, FL 33610

Job 2525538	Truss T01G	Truss Type GABLE	Qty 1	Ply 1	AMIRA BLDRS - THOMAS RES. Job Reference (optional)	T21805035
----------------	---------------	---------------------	----------	----------	---	-----------

Builders FirstSource (Jacksonville, FL),

Jacksonville, FL - 32244,

8.240 s Mar 9 2020 MiTek Industries, Inc. Thu Nov 5 09:18:42 2020 Page 1

ID:7WKr8toudn35dxwKwBAfQytHta-oL0kgPH9JXxA0WLNu0jRQDqllKIG3cSqwTJFGiyMH4h

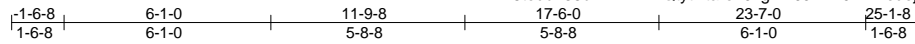

5x6 =

Scale = 1:67.8

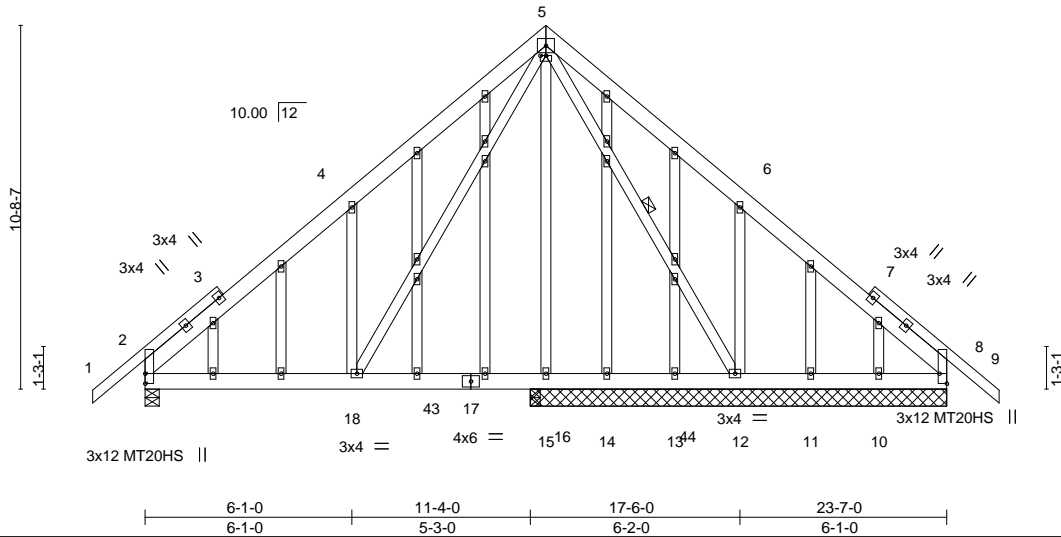

Plate Offsets (X,Y)-- [5:0-2-0,0-0-0], [8:Edge,0-2-9]

LOADING (psf)	SPACING-	2-0-0	CSI.	DEFL.	in (loc)	l/defl	L/d	PLATES	GRIP
TCLL 20.0	Plate Grip DOL	1.25	TC 0.48	Vert(LL)	-0.02	18	>999	MT20	244/190
TCDL 7.0	Lumber DOL	1.25	BC 0.19	Vert(CT)	-0.03	18	>999	MT20HS	187/143
BCLL 0.0 *	Rep Stress Incr	YES	WB 0.96	Horz(CT)	0.01	8	n/a		
BCDL 10.0	Code	FBC2017/TPI2014	Matrix-MS						
								Weight: 263 lb	FT = 20%

LUMBER-
TOP CHORD 2x6 SP No.2 *Except*
1-3,7-9: 2x4 SP No.2
BOT CHORD 2x6 SP No.2
WEBS 2x4 SP No.3
OTHERS 2x4 SP No.3

BRACING-
TOP CHORD Structural wood sheathing directly applied or 6-0-0 oc purlins.
BOT CHORD Rigid ceiling directly applied or 10-0-0 oc bracing.
WEBS 1 Row at midpt 5-12

REACTIONS. All bearings 12-3-0 except (jt=length) 2=0-5-0, 16=0-3-8.
(lb) - Max Horz 2=263(LC 10)
Max Uplift All uplift 100 lb or less at joint(s) 8, 10, 16 except 2=192(LC 12), 12=298(LC 13), 15=599(LC 19)
Max Grav All reactions 250 lb or less at joint(s) 8, 15, 10, 11, 13, 14, 8 except 2=671(LC 1), 12=710(LC 1), 16=802(LC 19)

FORCES. (lb) - Max. Comp./Max. Ten. - All forces 250 (lb) or less except when shown.
TOP CHORD 2-4=-613/210, 4-5=-723/459
BOT CHORD 2-18=-173/548, 16-18=-72/283, 15-16=-72/283, 14-15=-72/283, 13-14=-72/283, 12-13=-72/283
WEBS 5-12=-408/86, 6-12=-426/370, 5-18=-379/589, 4-18=-429/372

- NOTES-**
- Unbalanced roof live loads have been considered for this design.
 - Wind: ASCE 7-10; Vult=130mph (3-second gust) Vasd=101mph; TC DL=4.2psf; BCDL=3.0psf; h=20ft; Cat. II; Exp B; Encl., GCpi=0.18; MWFRS (envelope) gable end zone and C-C Exterior(2) zone; C-C for members and forces & MWFRS for reactions shown; Lumber DOL=1.60 plate grip DOL=1.60
 - Truss designed for wind loads in the plane of the truss only. For studs exposed to wind (normal to the face), see Standard Industry Gable End Details as applicable, or consult qualified building designer as per ANSI/TPI 1.
 - All plates are MT20 plates unless otherwise indicated.
 - All plates are 2x4 MT20 unless otherwise indicated.
 - Gable studs spaced at 2-0-0 oc.
 - This truss has been designed for a 10.0 psf bottom chord live load nonconcurrent with any other live loads.
 - * This truss has been designed for a live load of 20.0psf on the bottom chord in all areas where a rectangle 3-6-0 tall by 2-0-0 wide will fit between the bottom chord and any other members, with BCDL = 10.0psf.
 - Provide mechanical connection (by others) of truss to bearing plate capable of withstanding 100 lb uplift at joint(s) 8, 10, 16, 8 except (jt=lb) 2=192, 12=298, 15=599.

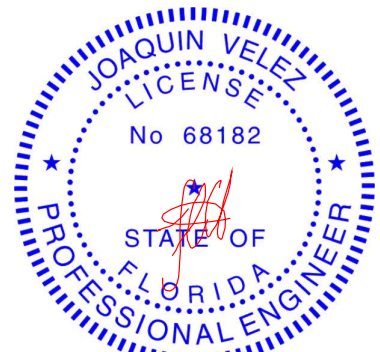

Joaquin Velez PE No.68182
MiTek USA, Inc. FL Cert 6634
6904 Parke East Blvd. Tampa FL 33610
Date:

November 5, 2020

WARNING - Verify design parameters and READ NOTES ON THIS AND INCLUDED MITEK REFERENCE PAGE MII-7473 rev. 5/19/2020 BEFORE USE.

Design valid for use only with MiTek® connectors. This design is based only upon parameters shown, and is for an individual building component, not a truss system. Before use, the building designer must verify the applicability of design parameters and properly incorporate this design into the overall building design. Bracing indicated is to prevent buckling of individual truss web and/or chord members only. Additional temporary and permanent bracing is always required for stability and to prevent collapse with possible personal injury and property damage. For general guidance regarding the fabrication, storage, delivery, erection and bracing of trusses and truss systems, see **ANSI/TPI1 Quality Criteria, DSB-89 and BCSI Building Component Safety Information** available from Truss Plate Institute, 2670 Crain Highway, Suite 203 Waldorf, MD 20601



6904 Parke East Blvd.
Tampa, FL 33610

Job 2525538	Truss T02	Truss Type Common	Qty 18	Ply 1	AMIRA BLDRS - THOMAS RES. T21805036
----------------	--------------	----------------------	-----------	----------	--

Builders FirstSource (Jacksonville, FL), Jacksonville, FL - 32244,

8.240 s Mar 9 2020 MiTek Industries, Inc. Thu Nov 5 09:18:43 2020 Page 1

ID:7Wkr8toudn35dxwKwBAfQtytHta-GXa6lln4r31egw_CbJy_em?qic2oBEz973op9yMH4g

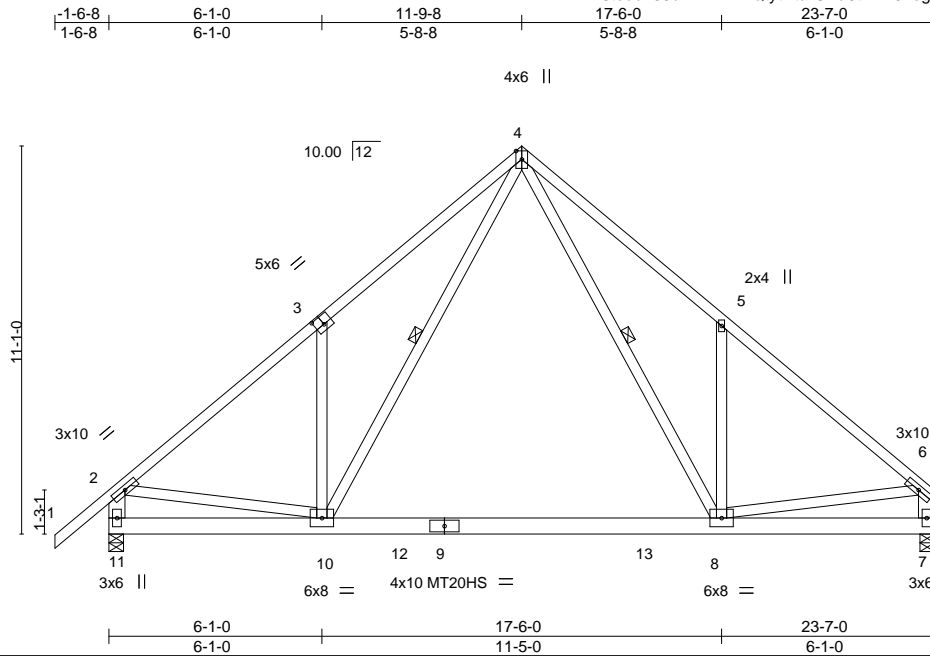

Scale = 1:65.8

Plate Offsets (X,Y)-- [3:0-3:0,0-3:0]

LOADING (psf)	SPACING-	CSI.	DEFL.	PLATES	GRIP
TCLL 20.0	2-0-0	TC 0.46	in (loc) l/defl L/d	MT20	244/190
TCDL 7.0	Plate Grip DOL 1.25	BC 0.41	Vert(LL) -0.23 8-10 >999 240	MT20HS	187/143
BCLL 0.0 *	Lumber DOL 1.25	WB 0.41	Vert(CT) -0.43 8-10 >647 180		
BCDL 10.0	Rep Stress Incr NO	Matrix-MS	Horz(CT) 0.01 7 n/a n/a		
	Code FBC2017/TPI2014			Weight: 176 lb	FT = 20%

LUMBER-

TOP CHORD 2x4 SP No.2
 BOT CHORD 2x6 SP M 26
 WEBS 2x4 SP No.3 *Except*
 2-11,6-7: 2x6 SP No.2

BRACING-

TOP CHORD Structural wood sheathing directly applied or 4-0-8 oc purlins, except end verticals.
 BOT CHORD Rigid ceiling directly applied or 6-0-0 oc bracing.
 WEBS 1 Row at midpt 4-8, 4-10

REACTIONS.

(size) 11=0-5-0, 7=0-5-0
 Max Horz 11=300(LC 9)
 Max Uplift 11=-347(LC 12), 7=-302(LC 13)
 Max Grav 11=1342(LC 19), 7=1231(LC 19)

FORCES.

(lb) - Max. Comp./Max. Ten. - All forces 250 (lb) or less except when shown.
 TOP CHORD 2-3=-1639/461, 3-4=-1704/692, 4-5=-1651/700, 5-6=-1661/456, 2-11=-1443/476,
 6-7=-1332/388
 BOT CHORD 10-11=-300/295, 8-10=-113/828
 WEBS 4-8=-473/1089, 5-8=-408/368, 4-10=-461/1117, 3-10=-387/349, 2-10=-185/1205,
 6-8=-217/1275

NOTES-

- Unbalanced roof live loads have been considered for this design.
- Wind: ASCE 7-10; Vult=130mph (3-second gust) Vasd=101mph; TC DL=4.2psf; BCDL=3.0psf; h=20ft; Cat. II; Exp B; Encl., GCpi=0.18; MWFRS (envelope) gable end zone and C-C Exterior(2) zone; end vertical left and right exposed; C-C for members and forces & MWFRS for reactions shown; Lumber DOL=1.60 plate grip DOL=1.60
- All plates are MT20 plates unless otherwise indicated.
- This truss has been designed for a 10.0 psf bottom chord live load nonconcurrent with any other live loads.
- * This truss has been designed for a live load of 20.0psf on the bottom chord in all areas where a rectangle 3-6-0 tall by 2-0-0 wide will fit between the bottom chord and any other members, with BCDL = 10.0psf.
- Provide mechanical connection (by others) of truss to bearing plate capable of withstanding 100 lb uplift at joint(s) except (jt=lb) 11=347, 7=302.
- In the LOAD CASE(S) section, loads applied to the face of the truss are noted as front (F) or back (B).

LOAD CASE(S) Standard

1) Dead + Roof Live (balanced): Lumber Increase=1.25, Plate Increase=1.25
 Uniform Loads (plf)
 Vert: 1-2=-54, 2-4=-54, 4-6=-54, 10-11=-20, 8-10=-80(F=-60), 7-8=-20

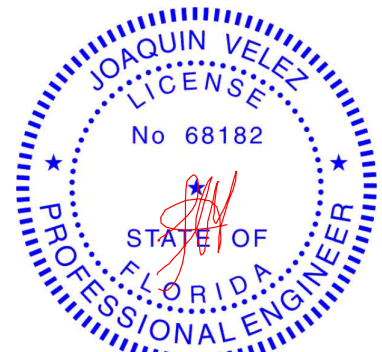

Joaquin Velez PE No.68182
 MiTek USA, Inc. FL Cert 6634
 6904 Parke East Blvd. Tampa FL 33610
 Date:

November 5, 2020

WARNING - Verify design parameters and READ NOTES ON THIS AND INCLUDED MITEK REFERENCE PAGE MII-7473 rev. 5/19/2020 BEFORE USE.

Design valid for use only with MiTek® connectors. This design is based only upon parameters shown, and is for an individual building component, not a truss system. Before use, the building designer must verify the applicability of design parameters and properly incorporate this design into the overall building design. Bracing indicated is to prevent buckling of individual truss web and/or chord members only. Additional temporary and permanent bracing is always required for stability and to prevent collapse with possible personal injury and property damage. For general guidance regarding the fabrication, storage, delivery, erection and bracing of trusses and truss systems, see **ANSI/TPI Quality Criteria, DSB-89 and BCSI Building Component Safety Information** available from Truss Plate Institute, 2670 Crain Highway, Suite 203 Waldorf, MD 20601



6904 Parke East Blvd.
 Tampa, FL 33610

Job 2525538	Truss T02G	Truss Type Common Supported Gable	Qty 1	Ply 1	AMIRA BLDRS - THOMAS RES. Job Reference (optional)	T21805037
----------------	---------------	--------------------------------------	----------	----------	---	-----------

Builders FirstSource (Jacksonville, FL),

Jacksonville, FL - 32244,

8.240 s Mar 9 2020 MiTek Industries, Inc. Thu Nov 5 09:18:45 2020 Page 1

ID:7WKr8toudn35dxwKwBafQtytHta-CwisIRJ1cSJt_4MJLQ33rPFVNMGBMGcRYvt1yMH4e

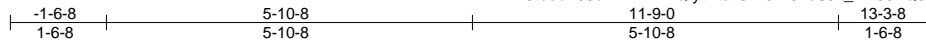

4x4 =

Scale = 1:37.0

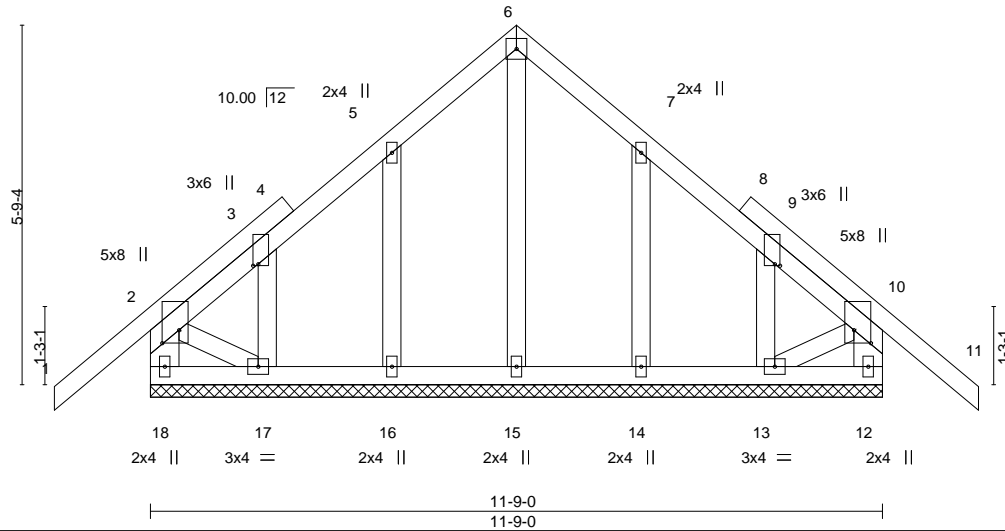

Plate Offsets (X,Y)-- [2:0-2-8,0-3-4], [3:0-0-5,0-1-0], [9:0-0-5,0-1-0], [10:0-2-8,0-3-4]

LOADING (psf)	SPACING-	2-0-0	CSI.	DEFL.	in (loc)	l/defl	L/d	PLATES	GRIP
TCLL 20.0	Plate Grip DOL	1.25	TC 0.20	Vert(LL)	-0.01	11	n/r	MT20	244/190
TCDL 7.0	Lumber DOL	1.25	BC 0.03	Vert(CT)	-0.02	11	n/r		
BCLL 0.0 *	Rep Stress Incr	YES	WB 0.05	Horz(CT)	0.00	12	n/a		
BCDL 10.0	Code FBC2017/TPI2014		Matrix-S						
								Weight: 86 lb	FT = 20%

LUMBER-

TOP CHORD 2x4 SP No.2
 BOT CHORD 2x4 SP No.2
 WEBS 2x6 SP No.2 *Except*
 2-17,10-13: 2x4 SP No.3
 OTHERS 2x4 SP No.3

BRACING-

TOP CHORD Structural wood sheathing directly applied or 6-0-0 oc purlins, except end verticals.
 BOT CHORD Rigid ceiling directly applied or 6-0-0 oc bracing.

REACTIONS.

All bearings 11-9-0.
 (lb) - Max Horz 18=177(LC 10)
 Max Uplift All uplift 100 lb or less at joint(s) 18, 12 except 16=103(LC 12), 17=134(LC 12), 14=103(LC 13), 13=128(LC 13)
 Max Grav All reactions 250 lb or less at joint(s) 18, 12, 15, 16, 17, 14, 13

FORCES.

(lb) - Max. Comp./Max. Ten. - All forces 250 (lb) or less except when shown.

NOTES-

- Unbalanced roof live loads have been considered for this design.
- Wind: ASCE 7-10; Vult=130mph (3-second gust) Vasd=101mph; TC DL=4.2psf; BCDL=3.0psf; h=20ft; Cat. II; Exp B; Encl., GCpi=0.18; MWFRS (envelope) gable end zone and C-C Exterior(2) zone; end vertical left and right exposed; C-C for members and forces & MWFRS for reactions shown; Lumber DOL=1.60 plate grip DOL=1.60
- Truss designed for wind loads in the plane of the truss only. For studs exposed to wind (normal to the face), see Standard Industry Gable End Details as applicable, or consult qualified building designer as per ANSI/TPI 1.
- Gable requires continuous bottom chord bearing.
- Truss to be fully sheathed from one face or securely braced against lateral movement (i.e. diagonal web).
- Gable studs spaced at 2-0-0 oc.
- This truss has been designed for a 10.0 psf bottom chord live load nonconcurrent with any other live loads.
- * This truss has been designed for a live load of 20.0psf on the bottom chord in all areas where a rectangle 3-6-0 tall by 2-0-0 wide will fit between the bottom chord and any other members.
- Provide mechanical connection (by others) of truss to bearing plate capable of withstanding 100 lb uplift at joint(s) 18, 12 except (jt=lb) 16=103, 17=134, 14=103, 13=128.

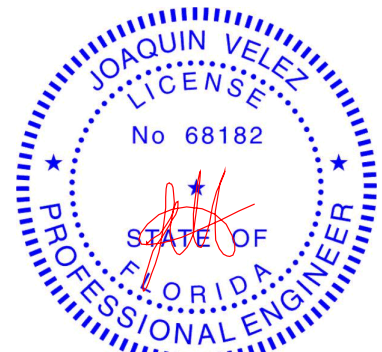

Joaquin Velez PE No.68182
 MiTek USA, Inc. FL Cert 6634
 6904 Parke East Blvd. Tampa FL 33610
 Date:

November 5, 2020

WARNING - Verify design parameters and READ NOTES ON THIS AND INCLUDED MITEK REFERENCE PAGE MII-7473 rev. 5/19/2020 BEFORE USE.

Design valid for use only with MiTek® connectors. This design is based only upon parameters shown, and is for an individual building component, not a truss system. Before use, the building designer must verify the applicability of design parameters and properly incorporate this design into the overall building design. Bracing indicated is to prevent buckling of individual truss web and/or chord members only. Additional temporary and permanent bracing is always required for stability and to prevent collapse with possible personal injury and property damage. For general guidance regarding the fabrication, storage, delivery, erection and bracing of trusses and truss systems, see **ANSI/TPI1 Quality Criteria, DSB-89 and BCSI Building Component Safety Information** available from Truss Plate Institute, 2670 Crain Highway, Suite 203 Waldorf, MD 20601



6904 Parke East Blvd.
 Tampa, FL 33610

Job 2525538	Truss T03	Truss Type Roof Special	Qty 6	Ply 1	AMIRA BLDRS - THOMAS RES. Job Reference (optional)	T21805038
----------------	--------------	----------------------------	----------	----------	---	-----------

Builders FirstSource (Jacksonville, FL), Jacksonville, FL - 32244,

8.240 s Mar 9 2020 MiTek Industries, Inc. Thu Nov 5 09:18:46 2020 Page 1

ID:7WKr8toudn35dxwKwBAFQtytHta-h6GFVnKfNmRbV8fZtjsgcGOYvvd9?WnQr5HSPUyMH4d

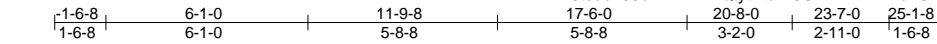

Scale = 1:69.4

Plate Offsets (X,Y)--	[3:0-3,0,0-3-0], [5:0-3-0,0-3-0], [13:0-1-8,0-1-0]				
LOADING (psf)	SPACING- 2-0-0	CSI.	DEFL. in (loc) l/defl L/d	PLATES	GRIP
TCLL 20.0	Plate Grip DOL 1.25	TC 0.34	Vert(LL) -0.06 12-13 >999 240	MT20	244/190
TCDL 7.0	Lumber DOL 1.25	BC 0.45	Vert(CT) -0.13 12-13 >999 180		
BCLL 0.0 *	Rep Stress Incr YES	WB 0.55	Horz(CT) 0.11 9 n/a n/a		
BCDL 10.0	Code FBC2017/TPI2014	Matrix-MS		Weight: 177 lb	FT = 20%

LUMBER-

TOP CHORD 2x4 SP No.2
 BOT CHORD 2x4 SP No.2 *Except*
 4-15,6-10: 2x4 SP No.3
 WEBS 2x4 SP No.3 *Except*
 2-17,7-9: 2x6 SP No.2

BRACING-

TOP CHORD Structural wood sheathing directly applied or 4-1-10 oc purlins, except end verticals.
 BOT CHORD Rigid ceiling directly applied or 10-0-0 oc bracing, Except: 6-0-0 oc bracing: 10-11,9-10. 10-0-0 oc bracing: 13-15

REACTIONS.

(size) 17=0-3-8, 9=0-3-8
 Max Horz 17=-305(LC 10)
 Max Uplift 17=-234(LC 12), 9=-234(LC 13)
 Max Grav 17=958(LC 1), 9=958(LC 1)

FORCES. (lb) - Max. Comp./Max. Ten. - All forces 250 (lb) or less except when shown.

TOP CHORD 2-3=-954/305, 3-4=-856/325, 4-5=-856/322, 5-6=-1282/368, 6-7=-1931/456, 2-17=-900/354, 7-9=-940/348
 BOT CHORD 16-17=-276/362, 4-13=-246/738, 12-13=-134/978, 11-12=-260/1498, 6-11=-62/525
 WEBS 13-16=-207/774, 5-13=-547/254, 5-12=-17/372, 6-12=-597/146, 2-16=-59/569, 7-11=-259/1452

NOTES-

- Unbalanced roof live loads have been considered for this design.
- Wind: ASCE 7-10; Vult=130mph (3-second gust) Vasd=101mph; TCDL=4.2psf; BCDL=3.0psf; h=20ft; Cat. II; Exp B; Encl., GCpi=0.18; MWFRS (envelope) gable end zone and C-C Exterior(2) zone; end vertical left exposed; C-C for members and forces & MWFRS for reactions shown; Lumber DOL=1.60 plate grip DOL=1.60
- This truss has been designed for a 10.0 psf bottom chord live load nonconcurrent with any other live loads.
- * This truss has been designed for a live load of 20.0psf on the bottom chord in all areas where a rectangle 3-6-0 tall by 2-0-0 wide will fit between the bottom chord and any other members.
- Provide mechanical connection (by others) of truss to bearing plate capable of withstanding 100 lb uplift at joint(s) except (jt=lb) 17=234, 9=234.

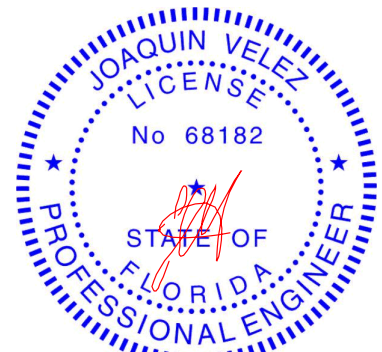

Joaquin Velez PE No.68182
 MiTek USA, Inc. FL Cert 6634
 6904 Parke East Blvd. Tampa FL 33610
 Date:

November 5, 2020

WARNING - Verify design parameters and READ NOTES ON THIS AND INCLUDED MITEK REFERENCE PAGE MII-7473 rev. 5/19/2020 BEFORE USE.

Design valid for use only with MiTek® connectors. This design is based only upon parameters shown, and is for an individual building component, not a truss system. Before use, the building designer must verify the applicability of design parameters and properly incorporate this design into the overall building design. Bracing indicated is to prevent buckling of individual truss web and/or chord members only. Additional temporary and permanent bracing is always required for stability and to prevent collapse with possible personal injury and property damage. For general guidance regarding the fabrication, storage, delivery, erection and bracing of trusses and truss systems, see **ANSI/TPI1 Quality Criteria, DSB-89 and BCSI Building Component Safety Information** available from Truss Plate Institute, 2670 Crain Highway, Suite 203 Waldorf, MD 20601



6904 Parke East Blvd.
 Tampa, FL 33610

Job 2525538	Truss T04	Truss Type Common	Qty 1	Ply 1	AMIRA BLDRS - THOMAS RES. Job Reference (optional)	T21805039
----------------	--------------	----------------------	----------	----------	---	-----------

Builders FirstSource (Jacksonville, FL),

Jacksonville, FL - 32244,

8.240 s Mar 9 2020 MiTek Industries, Inc. Thu Nov 5 09:18:48 2020 Page 1

ID:7WKr8toudn35dxwKwBAfQtytHta-dVN?wTMvNhhJlRox?8v8hhTtKjKHTPAjIpmZUMyMH4b

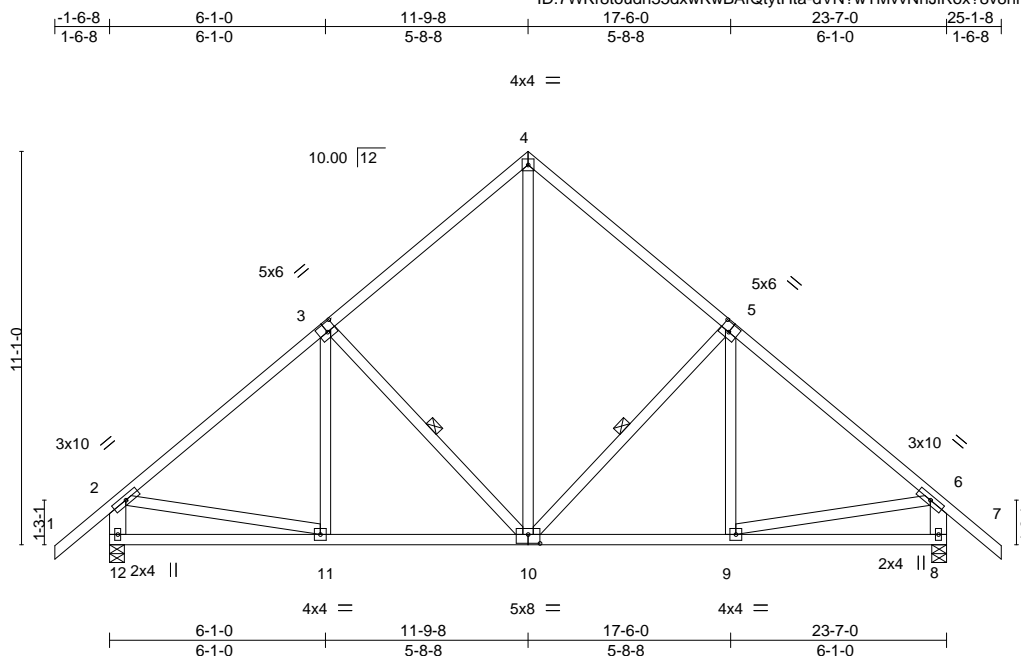

Scale = 1:64.9

Plate Offsets (X,Y)--	[3:0-3-0,0-3-0], [5:0-3-0,0-3-0], [10:0-4-0,0-3-0]				
LOADING (psf)	SPACING- 2-0-0	CSI.	DEFL. in (loc) l/defl L/d	PLATES	GRIP
TCLL 20.0	Plate Grip DOL 1.25	TC 0.34	Vert(LL) -0.03 11-12 >999 240	MT20	244/190
TCDL 7.0	Lumber DOL 1.25	BC 0.34	Vert(CT) -0.06 11-12 >999 180		
BCLL 0.0 *	Rep Stress Incr YES	WB 0.62	Horz(CT) 0.01 8 n/a n/a		
BCDL 10.0	Code FBC2017/TPI2014	Matrix-MS		Weight: 165 lb	FT = 20%

LUMBER-

TOP CHORD 2x4 SP No.2
 BOT CHORD 2x4 SP No.2
 WEBS 2x4 SP No.3 *Except*
 2-12,6-8: 2x6 SP No.2

BRACING-

TOP CHORD Structural wood sheathing directly applied or 5-9-12 oc purlins, except end verticals.
 BOT CHORD Rigid ceiling directly applied or 10-0-0 oc bracing.
 WEBS 1 Row at midpt 5-10, 3-10

REACTIONS.

(size) 12=0-5-0, 8=0-5-0
 Max Horz 12=-315(LC 10)
 Max Uplift 12=-236(LC 12), 8=-236(LC 13)
 Max Grav 12=951(LC 1), 8=951(LC 1)

FORCES.

(lb) - Max. Comp./Max. Ten. - All forces 250 (lb) or less except when shown.
 TOP CHORD 2-3=-942/306, 3-4=-713/347, 4-5=-713/347, 5-6=-942/306, 2-12=-896/357, 6-8=-896/357
 BOT CHORD 11-12=-293/368, 10-11=-181/748, 9-10=-73/648
 WEBS 4-10=-281/615, 5-10=-351/251, 3-10=-351/251, 2-11=-60/564, 6-9=-60/564

NOTES-

- Unbalanced roof live loads have been considered for this design.
- Wind: ASCE 7-10; Vult=130mph (3-second gust) Vasd=101mph; TC DL=4.2psf; BC DL=3.0psf; h=20ft; Cat. II; Exp B; Encl., GCpi=0.18; MWFRS (envelope) gable end zone and C-C Exterior(2) zone; end vertical left and right exposed; C-C for members and forces & MWFRS for reactions shown; Lumber DOL=1.60 plate grip DOL=1.60
- This truss has been designed for a 10.0 psf bottom chord live load nonconcurrent with any other live loads.
- * This truss has been designed for a live load of 20.0psf on the bottom chord in all areas where a rectangle 3-6-0 tall by 2-0-0 wide will fit between the bottom chord and any other members.
- Provide mechanical connection (by others) of truss to bearing plate capable of withstanding 100 lb uplift at joint(s) except (jt=lb) 12=236, 8=236.

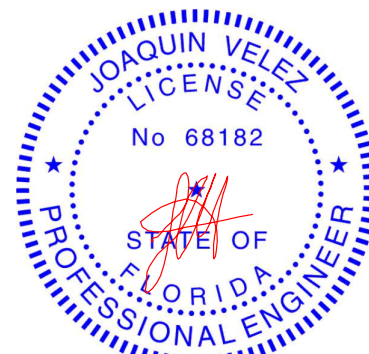

Joaquin Velez PE No.68182
 MiTek USA, Inc. FL Cert 6634
 6904 Parke East Blvd. Tampa FL 33610
 Date:

November 5, 2020

WARNING - Verify design parameters and READ NOTES ON THIS AND INCLUDED MITEK REFERENCE PAGE MII-7473 rev. 5/19/2020 BEFORE USE.

Design valid for use only with MiTek® connectors. This design is based only upon parameters shown, and is for an individual building component, not a truss system. Before use, the building designer must verify the applicability of design parameters and properly incorporate this design into the overall building design. Bracing indicated is to prevent buckling of individual truss web and/or chord members only. Additional temporary and permanent bracing is always required for stability and to prevent collapse with possible personal injury and property damage. For general guidance regarding the fabrication, storage, delivery, erection and bracing of trusses and truss systems, see **ANSI/TPI1 Quality Criteria, DSB-89 and BCSI Building Component Safety Information** available from Truss Plate Institute, 2670 Crain Highway, Suite 203 Waldorf, MD 20601



6904 Parke East Blvd.
 Tampa, FL 33610

Job 2525538	Truss T04G	Truss Type Common Supported Gable	Qty 1	Ply 1	AMIRA BLDRS - THOMAS RES. Job Reference (optional)	T21805040
----------------	---------------	--------------------------------------	----------	----------	---	-----------

Builders FirstSource (Jacksonville, FL),

Jacksonville, FL - 32244,

8.240 s Mar 9 2020 MiTek Industries, Inc. Thu Nov 5 09:18:50 2020 Page 1

ID:7Wkr8toudn35dxwKwBAfQtytHta-ZiVL8NAQ_x1_lyK6Zxcm6YF6W5lxRS?mjFgZFYMH4Z

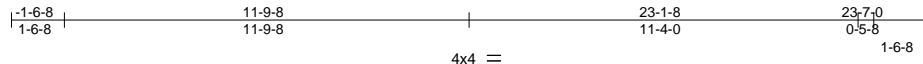

Scale = 1:67.1

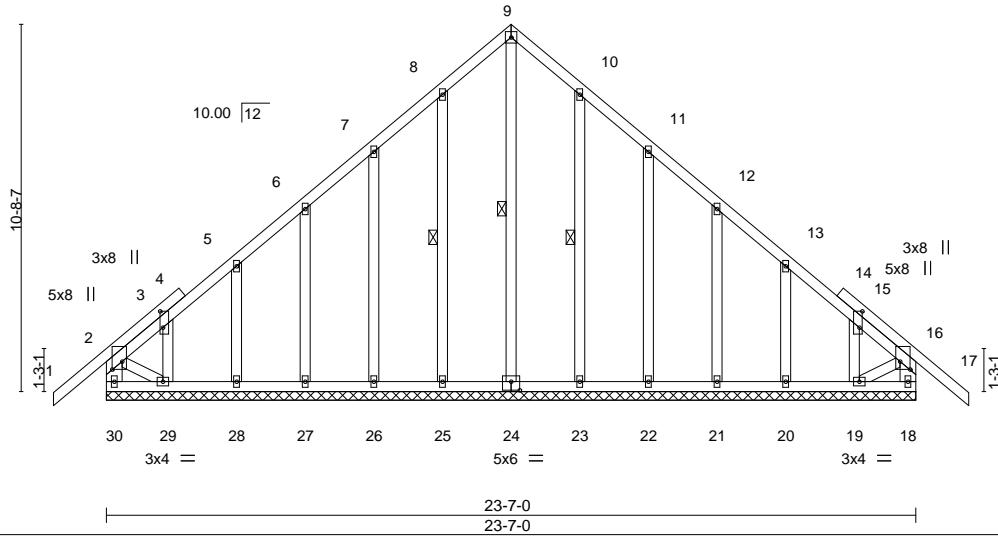

Plate Offsets (X,Y)-- [2:0-2-12,0-3-8], [3:0-5-11,0-1-0], [15:0-5-11,0-1-0], [16:0-2-12,0-3-8], [24:0-3-0,0-3-0]

LOADING (psf)	SPACING-	2-0-0	CSI.	DEFL.	in (loc)	l/defl	L/d	PLATES	GRIP
TCLL 20.0	Plate Grip DOL	1.25	TC 0.20	Vert(LL)	-0.01	17	n/r	MT20	244/190
TCDL 7.0	Lumber DOL	1.25	BC 0.05	Vert(CT)	-0.02	17	n/r		
BCLL 0.0 *	Rep Stress Incr	YES	WB 0.13	Horz(CT)	0.01	18	n/a		
BCDL 10.0	Code	FBC2017/TPI2014	Matrix-S						
								Weight: 194 lb	FT = 20%

LUMBER-
TOP CHORD 2x4 SP No.2
BOT CHORD 2x4 SP No.2
WEBS 2x6 SP No.2 *Except*
2-29,16-19: 2x4 SP No.3
OTHERS 2x4 SP No.3

BRACING-
TOP CHORD Structural wood sheathing directly applied or 6-0-0 oc purlins, except end verticals.
BOT CHORD Rigid ceiling directly applied or 10-0-0 oc bracing, Except: 6-0-0 oc bracing: 29-30,18-19.
WEBS 1 Row at midpt 9-24, 8-25, 10-23

REACTIONS. All bearings 23-7-0.
(lb) - Max Horz 30=265(LC 11)
Max Uplift All uplift 100 lb or less at joint(s) 18, 25, 28, 23, 20 except 30=-127(LC 8), 26=-105(LC 12), 27=-104(LC 12), 29=-212(LC 12), 22=-107(LC 13), 21=-103(LC 13), 19=-191(LC 13)
Max Grav All reactions 250 lb or less at joint(s) 18, 24, 25, 26, 27, 28, 29, 23, 22, 21, 20, 19 except 30=271(LC 20)

FORCES. (lb) - Max. Comp./Max. Ten. - All forces 250 (lb) or less except when shown.
TOP CHORD 2-30=-254/162, 2-3=-258/181

- NOTES-**
- Unbalanced roof live loads have been considered for this design.
 - Wind: ASCE 7-10; Vult=130mph (3-second gust) Vasd=101mph; TCDL=4.2psf; BCDL=3.0psf; h=20ft; Cat. II; Exp B; Encl., GCpi=0.18; MWFRS (envelope) gable end zone and C-C Exterior(2) zone; C-C for members and forces & MWFRS for reactions shown; Lumber DOL=1.60 plate grip DOL=1.60
 - Truss designed for wind loads in the plane of the truss only. For studs exposed to wind (normal to the face), see Standard Industry Gable End Details as applicable, or consult qualified building designer as per ANSI/TPI 1.
 - All plates are 2x4 MT20 unless otherwise indicated.
 - Gable requires continuous bottom chord bearing.
 - Truss to be fully sheathed from one face or securely braced against lateral movement (i.e. diagonal web).
 - Gable studs spaced at 2-0-0 oc.
 - This truss has been designed for a 10.0 psf bottom chord live load nonconcurrent with any other live loads.
 - * This truss has been designed for a live load of 20.0psf on the bottom chord in all areas where a rectangle 3-6-0 tall by 2-0-0 wide will fit between the bottom chord and any other members.
 - Provide mechanical connection (by others) of truss to bearing plate capable of withstanding 100 lb uplift at joint(s) 18, 25, 28, 23, 20 except (jt=lb) 30=127, 26=105, 27=104, 29=212, 22=107, 21=103, 19=191.

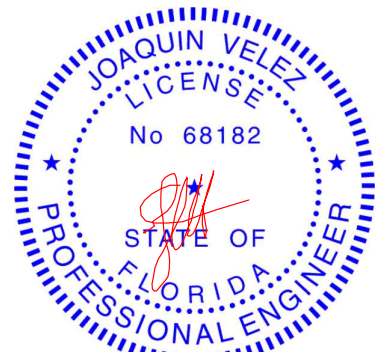

Joaquin Velez PE No.68182
MiTek USA, Inc. FL Cert 6634
6904 Parke East Blvd. Tampa FL 33610
Date:

November 5,2020

WARNING - Verify design parameters and READ NOTES ON THIS AND INCLUDED MITEK REFERENCE PAGE MII-7473 rev. 5/19/2020 BEFORE USE.
Design valid for use only with MiTek® connectors. This design is based only upon parameters shown, and is for an individual building component, not a truss system. Before use, the building designer must verify the applicability of design parameters and properly incorporate this design into the overall building design. Bracing indicated is to prevent buckling of individual truss web and/or chord members only. Additional temporary and permanent bracing is always required for stability and to prevent collapse with possible personal injury and property damage. For general guidance regarding the fabrication, storage, delivery, erection and bracing of trusses and truss systems, see **ANSI/TPI1 Quality Criteria, DSB-89 and BCSI Building Component Safety Information** available from Truss Plate Institute, 2670 Crain Highway, Suite 203 Waldorf, MD 20601



6904 Parke East Blvd.
Tampa, FL 33610

Job 2525538	Truss T05	Truss Type Roof Special	Qty 5	Ply 1	AMIRA BLDRS - THOMAS RES. T21805041
----------------	--------------	----------------------------	----------	----------	--

Builders FirstSource (Jacksonville, FL), Jacksonville, FL - 32244, 8.240 s Mar 9 2020 MiTek Industries, Inc. Thu Nov 5 09:18:51 2020 Page 1

ID:7WKr8toudn35dxwKwBAfQtytHta-1438ZUOoBI4ucvXWgHSrJK5K0wFngke9_N?D5hyMH4Y

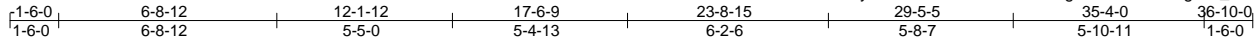

5x6 =

Scale = 1:71.1

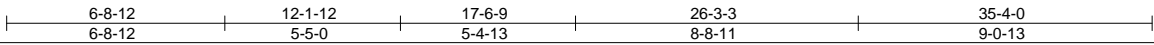
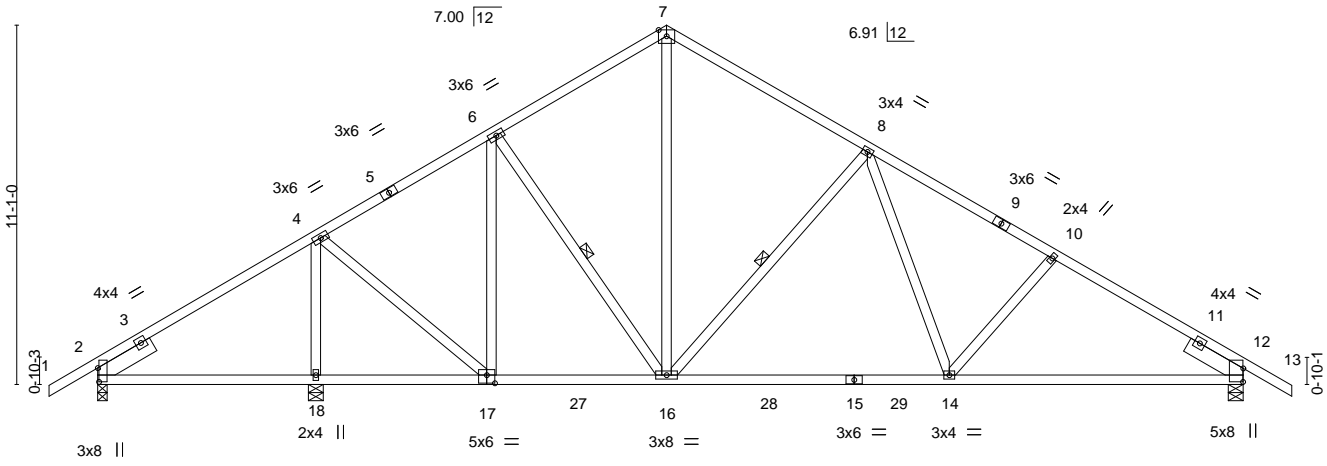

Plate Offsets (X,Y)-- [2:0-5-2,0-0-7], [12:0-5-0,0-0-1], [17:0-3-0,0-3-0]

LOADING (psf)	SPACING-	2-0-0	CSI.	DEFL.	in (loc)	l/defl	L/d	PLATES	GRIP
TCLL 20.0	Plate Grip DOL	1.25	TC 0.63	Vert(LL)	0.08 18-21	>990	240	MT20	244/190
TCDL 7.0	Lumber DOL	1.25	BC 0.74	Vert(CT)	-0.37 14-16	>921	180		
BCLL 0.0 *	Rep Stress Incr	YES	WB 0.71	Horz(CT)	0.06 12	n/a	n/a		
BCDL 10.0	Code	FBC2017/TPI2014	Matrix-MS					Weight: 216 lb	FT = 20%

LUMBER-
 TOP CHORD 2x4 SP No.2
 BOT CHORD 2x4 SP No.2
 WEBS 2x4 SP No.3
 SLIDER Left 2x6 SP No.2 1-11-8, Right 2x6 SP No.2 1-11-8

BRACING-
 TOP CHORD Structural wood sheathing directly applied or 3-6-5 oc purlins.
 BOT CHORD Rigid ceiling directly applied or 6-0-0 oc bracing.
 WEBS 1 Row at midt 6-16, 8-16

REACTIONS. (size) 2=0-3-8, 18=0-5-8, 12=0-5-8
 Max Horz 2=-275(LC 10)
 Max Uplift 2=-178(LC 12), 18=-230(LC 12), 12=-329(LC 13)
 Max Grav 2=434(LC 23), 18=1276(LC 19), 12=1149(LC 1)

FORCES. (lb) - Max. Comp./Max. Ten. - All forces 250 (lb) or less except when shown.
 TOP CHORD 2-4=-241/363, 4-6=-823/461, 6-7=-877/478, 7-8=-889/473, 8-10=-1418/549,
 10-12=-1550/554
 BOT CHORD 2-18=-327/239, 17-18=-327/239, 16-17=-191/760, 14-16=-237/1043, 12-14=-368/1268
 WEBS 4-18=-1157/241, 4-17=-83/840, 6-17=-410/85, 7-16=-316/620, 8-16=-628/315,
 8-14=-93/416

- NOTES-**
- Unbalanced roof live loads have been considered for this design.
 - Wind: ASCE 7-10; Vult=130mph (3-second gust) Vasd=101mph; TC DL=4.2psf; BCDL=3.0psf; h=20ft; Cat. II; Exp B; Encl., GCpi=0.18; MWFRS (envelope) gable end zone and C-C Exterior(2) zone; porch left exposed; C-C for members and forces & MWFRS for reactions shown; Lumber DOL=1.60 plate grip DOL=1.60
 - This truss has been designed for a 10.0 psf bottom chord live load nonconcurrent with any other live loads.
 - * This truss has been designed for a live load of 20.0psf on the bottom chord in all areas where a rectangle 3-6-0 tall by 2-0-0 wide will fit between the bottom chord and any other members, with BCDL = 10.0psf.
 - Provide mechanical connection (by others) of truss to bearing plate capable of withstanding 100 lb uplift at joint(s) except (jt=lb) 2=178, 18=230, 12=329.

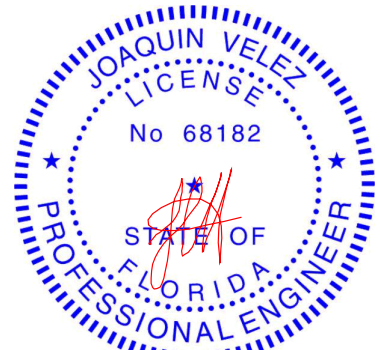

Joaquin Velez PE No.68182
 MiTek USA, Inc. FL Cert 6634
 6904 Parke East Blvd. Tampa FL 33610
 Date:

November 5, 2020

WARNING - Verify design parameters and READ NOTES ON THIS AND INCLUDED MITEK REFERENCE PAGE MII-7473 rev. 5/19/2020 BEFORE USE.
 Design valid for use only with MiTek® connectors. This design is based only upon parameters shown, and is for an individual building component, not a truss system. Before use, the building designer must verify the applicability of design parameters and properly incorporate this design into the overall building design. Bracing indicated is to prevent buckling of individual truss web and/or chord members only. Additional temporary and permanent bracing is always required for stability and to prevent collapse with possible personal injury and property damage. For general guidance regarding the fabrication, storage, delivery, erection and bracing of trusses and truss systems, see **ANSI/TPI1 Quality Criteria, DSB-89 and BCSI Building Component Safety Information** available from Truss Plate Institute, 2670 Crain Highway, Suite 203 Waldorf, MD 20601



Job 2525538	Truss T06	Truss Type Common	Qty 1	Ply 1	AMIRA BLDRS - THOMAS RES.	T21805042
----------------	--------------	----------------------	----------	----------	---------------------------	-----------

Builders FirstSource (Jacksonville, FL), Jacksonville, FL - 32244,

8.240 s Mar 9 2020 MiTek Industries, Inc. Thu Nov 5 09:18:53 2020 Page 1

ID:7Wkr8toudn35dxwKwBAfQtytHta-zSBuzAQ2jvKcrChvnhUJQIAkBk_H8bPSShUK9ayMH4W

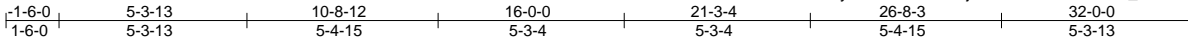

4x4 =

Scale = 1:65.2

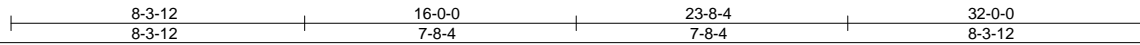
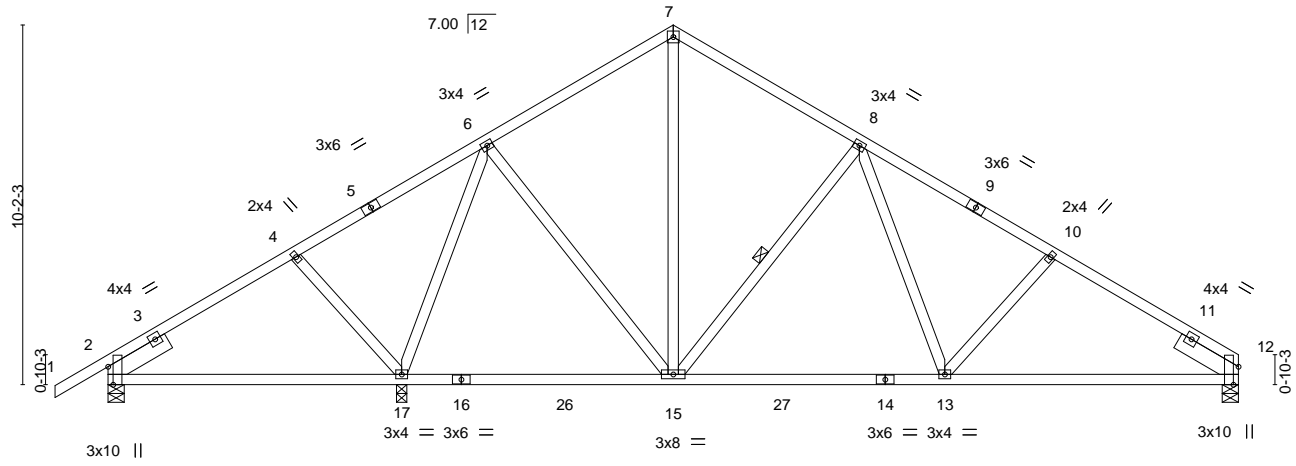

Plate Offsets (X,Y)--	[2:0-6-2,Edge], [12:0-6-2,Edge]								
LOADING (psf)	SPACING-	2-0-0	CSI.	DEFL.	in (loc)	l/defl	L/d	PLATES	GRIP
TCLL 20.0	Plate Grip DOL 1.25		TC 0.34	Vert(LL) -0.11	13-15	>999	240	MT20	244/190
TCDL 7.0	Lumber DOL 1.25		BC 0.54	Vert(CT) -0.18	13-15	>999	180		
BCLL 0.0 *	Rep Stress Incr YES		WB 0.94	Horz(CT) 0.03	12	n/a	n/a		
BCDL 10.0	Code FBC2017/TPI2014		Matrix-MS						
								Weight: 188 lb	FT = 20%

LUMBER-
 TOP CHORD 2x4 SP No.2
 BOT CHORD 2x4 SP No.2
 WEBS 2x4 SP No.3
 SLIDER Left 2x6 SP No.2 1-11-8, Right 2x6 SP No.2 1-11-8

BRACING-
 TOP CHORD Structural wood sheathing directly applied or 4-10-14 oc purlins.
 BOT CHORD Rigid ceiling directly applied or 10-0-0 oc bracing, Except:
 6-0-0 oc bracing: 2-17.
 WEBS 1 Row at midpt 8-15

REACTIONS. (size) 2=0-5-8, 17=0-3-8, 12=0-5-8
 Max Horz 2=245(LC 11)
 Max Uplift 2=98(LC 12), 17=319(LC 12), 12=231(LC 13)
 Max Grav 2=390(LC 23), 17=1308(LC 19), 12=856(LC 20)

FORCES. (lb) - Max. Comp./Max. Ten. - All forces 250 (lb) or less except when shown.
 TOP CHORD 2-4=478/75, 6-7=615/302, 7-8=617/302, 8-10=1068/378, 10-12=1191/386
 BOT CHORD 2-17=190/280, 15-17=107/312, 13-15=122/739, 12-13=260/972
 WEBS 7-15=163/391, 8-15=556/289, 8-13=99/381, 6-15=49/447, 6-17=937/317,
 4-17=299/207

- NOTES-**
- 1) Unbalanced roof live loads have been considered for this design.
 - 2) Wind: ASCE 7-10; Vult=130mph (3-second gust) Vasd=101mph; TC DL=4.2psf; BCDL=3.0psf; h=20ft; Cat. II; Exp B; Encl., GCpi=0.18; MWFRS (envelope) gable end zone and C-C Exterior(2) zone; C-C for members and forces & MWFRS for reactions shown; Lumber DOL=1.60 plate grip DOL=1.60
 - 3) This truss has been designed for a 10.0 psf bottom chord live load nonconcurrent with any other live loads.
 - 4) * This truss has been designed for a live load of 20.0psf on the bottom chord in all areas where a rectangle 3-6-0 tall by 2-0-0 wide will fit between the bottom chord and any other members, with BCDL = 10.0psf.
 - 5) Provide mechanical connection (by others) of truss to bearing plate capable of withstanding 100 lb uplift at joint(s) 2 except (jt=lb) 17=319, 12=231.

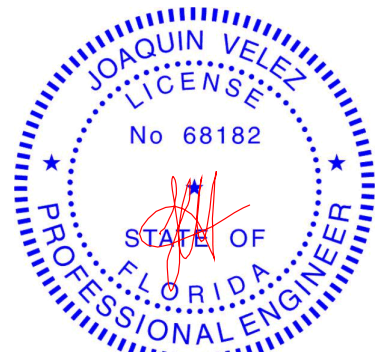

Joaquin Velez PE No.68182
 MiTek USA, Inc. FL Cert 6634
 6904 Parke East Blvd. Tampa FL 33610
 Date:

November 5, 2020

WARNING - Verify design parameters and READ NOTES ON THIS AND INCLUDED MITEK REFERENCE PAGE MII-7473 rev. 5/19/2020 BEFORE USE.

Design valid for use only with MiTek® connectors. This design is based only upon parameters shown, and is for an individual building component, not a truss system. Before use, the building designer must verify the applicability of design parameters and properly incorporate this design into the overall building design. Bracing indicated is to prevent buckling of individual truss web and/or chord members only. Additional temporary and permanent bracing is always required for stability and to prevent collapse with possible personal injury and property damage. For general guidance regarding the fabrication, storage, delivery, erection and bracing of trusses and truss systems, see **ANSI/TPI1 Quality Criteria, DSB-89 and BCSI Building Component Safety Information** available from Truss Plate Institute, 2670 Crain Highway, Suite 203 Waldorf, MD 20601



6904 Parke East Blvd.
 Tampa, FL 33610

Job 2525538	Truss T06G	Truss Type Common Supported Gable	Qty 1	Ply 1	AMIRA BLDRS - THOMAS RES. Job Reference (optional)	T21805043
----------------	---------------	--------------------------------------	----------	----------	---	-----------

Builders FirstSource (Jacksonville, FL), Jacksonville, FL - 32244,

8.240 s Mar 9 2020 MiTek Industries, Inc. Thu Nov 5 09:18:56 2020 Page 1

ID:7WKr8toudn35dxwKwBAfQtytHta-O1s1cCSx0qiBigQUTq200NoB7x8jL97u8fi_mvyMH4T

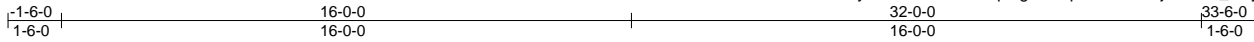

Scale = 1:64.7

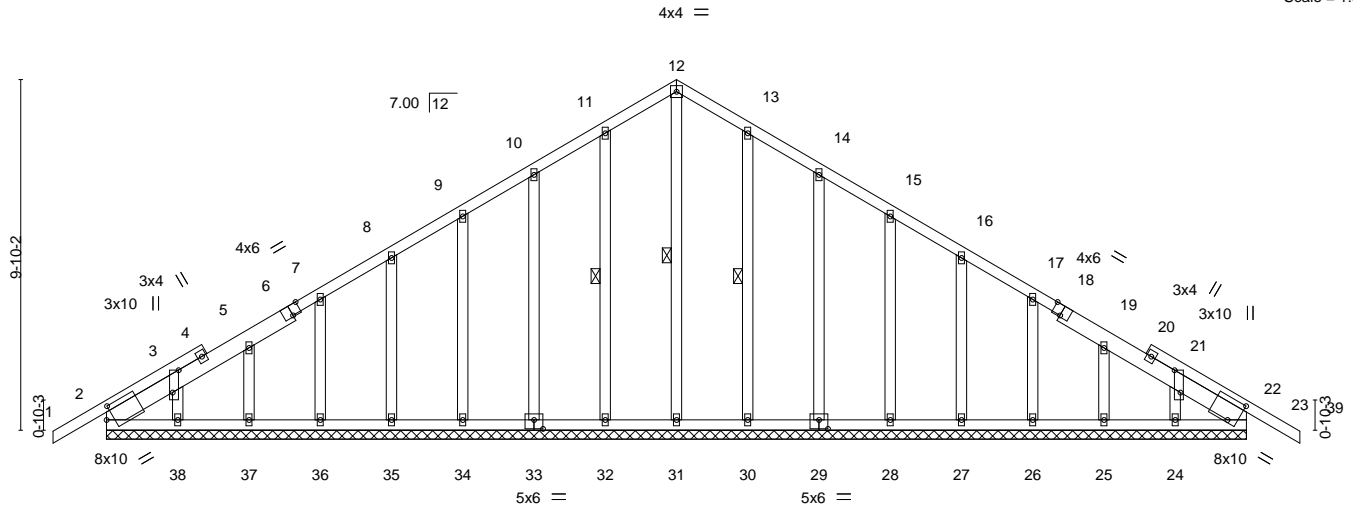

Plate Offsets (X,Y)--	[2:0-2-7,0-3-15], [3:0-7-8,Edge], [6:0-3-0,Edge], [18:0-3-0,Edge], [21:0-7-8,Edge], [22:0-3-1,0-7-3], [29:0-3-0,0-3-0], [33:0-3-0,0-3-0]
-----------------------	--

LOADING (psf)	SPACING-	2-0-0	CSI.	DEFL.	in (loc)	l/defl	L/d	PLATES	GRIP
TCLL 20.0	Plate Grip DOL	1.25	TC 0.61	Vert(LL)	0.01	23	n/r	MT20	244/190
TCDL 7.0	Lumber DOL	1.25	BC 0.05	Vert(CT)	-0.01	23	n/r		
BCLL 0.0 *	Rep Stress Incr	YES	WB 0.11	Horz(CT)	0.01	22	n/a		
BCDL 10.0	Code	FBC2017/TPI2014	Matrix-S					Weight: 237 lb	FT = 20%

LUMBER-	BRACING-
TOP CHORD 2x4 SP No.2 *Except* 2-6,18-22: 2x6 SP No.2	TOP CHORD Structural wood sheathing directly applied or 6-0-0 oc purlins.
BOT CHORD 2x4 SP No.2	BOT CHORD Rigid ceiling directly applied or 10-0-0 oc bracing, Except: 6-0-0 oc bracing: 22-24.
OTHERS 2x4 SP No.3	WEBS 1 Row at midpt 12-31, 11-32, 13-30

REACTIONS. All bearings 32-0-0.
 (lb) - Max Horz 2=-244(LC 10)
 Max Uplift All uplift 100 lb or less at joint(s) 2, 32, 33, 34, 35, 36, 37, 38, 30, 29, 28, 27, 26, 25 except
 24=-141(LC 36), 22=-298(LC 9)
 Max Grav All reactions 250 lb or less at joint(s) 2, 31, 32, 33, 34, 35, 36, 37, 38, 30, 29, 28, 27, 26, 25
 except 24=261(LC 11), 22=548(LC 1)

FORCES. (lb) - Max. Comp./Max. Ten. - All forces 250 (lb) or less except when shown.
 WEBS 21-24=-267/162

- NOTES-**
- Unbalanced roof live loads have been considered for this design.
 - Wind: ASCE 7-10; Vult=130mph (3-second gust) Vasd=101mph; TCDL=4.2psf; BCDL=3.0psf; h=20ft; Cat. II; Exp B; Encl., GCpi=0.18; MWFRS (envelope) gable end zone and C-C Exterior(2) zone; C-C for members and forces & MWFRS for reactions shown; Lumber DOL=1.60 plate grip DOL=1.60
 - Truss designed for wind loads in the plane of the truss only. For studs exposed to wind (normal to the face), see Standard Industry Gable End Details as applicable, or consult qualified building designer as per ANSI/TPI 1.
 - All plates are 2x4 MT20 unless otherwise indicated.
 - Gable requires continuous bottom chord bearing.
 - Gable studs spaced at 2-0-0 oc.
 - This truss has been designed for a 10.0 psf bottom chord live load nonconcurrent with any other live loads.
 - * This truss has been designed for a live load of 20.0psf on the bottom chord in all areas where a rectangle 3-6-0 tall by 2-0-0 wide will fit between the bottom chord and any other members.
 - Provide mechanical connection (by others) of truss to bearing plate capable of withstanding 100 lb uplift at joint(s) 2, 32, 33, 34, 35, 36, 37, 38, 30, 29, 28, 27, 26, 25 except (jt=lb) 24=141, 22=298.
 - Hanger(s) or other connection device(s) shall be provided sufficient to support concentrated load(s) 240 lb down and 193 lb up at 33-2-3 on top chord. The design/selection of such connection device(s) is the responsibility of others.

LOAD CASE(S) Standard
 1) Dead + Roof Live (balanced): Lumber Increase=1.25, Plate Increase=1.25
 Uniform Loads (plf)
 Vert: 1-12=-54, 12-23=-54, 2-22=-20
 Concentrated Loads (lb)
 Vert: 39=-214

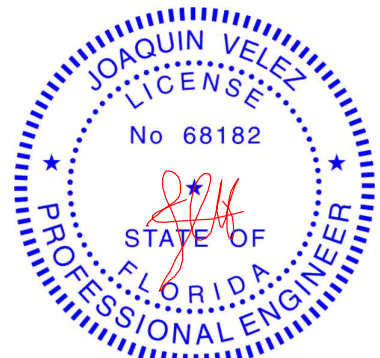

Joaquin Velez PE No.68182
 MiTek USA, Inc. FL Cert 6634
 6904 Parke East Blvd. Tampa FL 33610
 Date:

November 5,2020

WARNING - Verify design parameters and READ NOTES ON THIS AND INCLUDED MITEK REFERENCE PAGE MII-7473 rev. 5/19/2020 BEFORE USE.
 Design valid for use only with MiTek® connectors. This design is based only upon parameters shown, and is for an individual building component, not a truss system. Before use, the building designer must verify the applicability of design parameters and properly incorporate this design into the overall building design. Bracing indicated is to prevent buckling of individual truss web and/or chord members only. Additional temporary and permanent bracing is always required for stability and to prevent collapse with possible personal injury and property damage. For general guidance regarding the fabrication, storage, delivery, erection and bracing of trusses and truss systems, see **ANSI/TPI1 Quality Criteria, DSB-89 and BCSI Building Component Safety Information** available from Truss Plate Institute, 2670 Crain Highway, Suite 203 Waldorf, MD 20601



6904 Parke East Blvd.
 Tampa, FL 36610

Job 2525538	Truss T07G	Truss Type GABLE	Qty 1	Ply 1	AMIRA BLDRS - THOMAS RES. Job Reference (optional)	T21805045
----------------	---------------	---------------------	----------	----------	---	-----------

Builders FirstSource (Jacksonville, FL), Jacksonville, FL - 32244, 8.240 s Mar 9 2020 MiTek Industries, Inc. Thu Nov 5 09:19:01 2020 Page 1

ID:7WKr8toudn35dxwKwBAfQtytHta-k?gwfvW3rNKToRIRFNeBjRV4Lyhx0EodlxQIR6yMH40

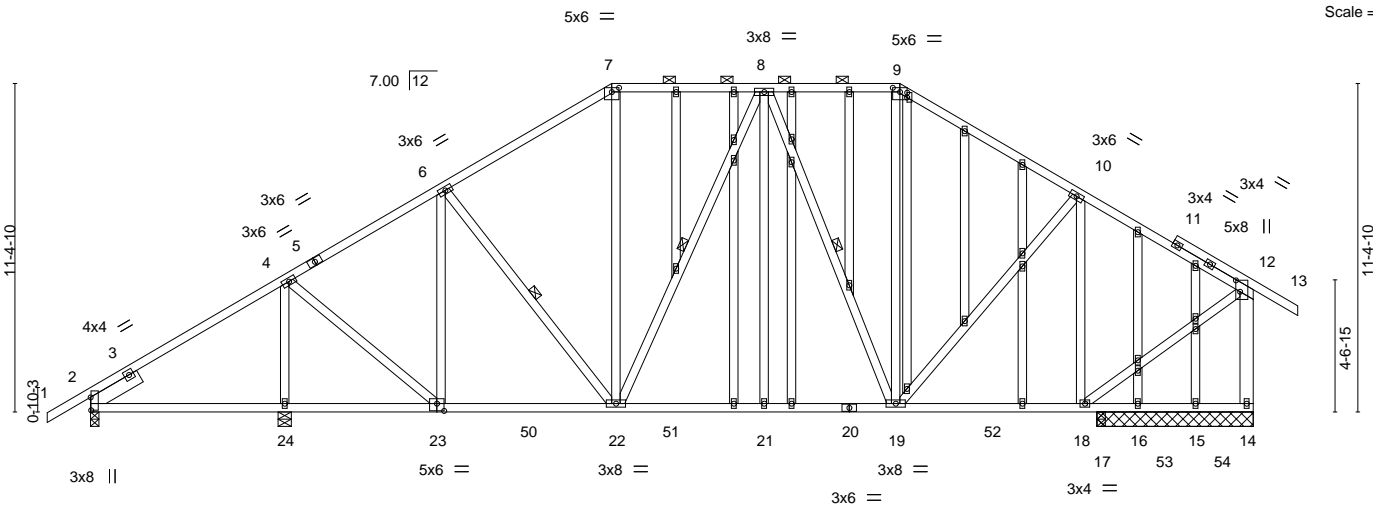
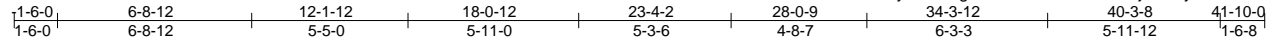

6-8-12	12-1-12	18-0-12	23-4-2	28-0-9	34-3-12	35-2-0	40-3-8
6-8-12	5-5-0	5-11-0	5-3-6	4-8-7	6-3-3	0-10-4	5-1-8

LOADING (psf)	SPACING-	2-0-0	CSI.	DEFL.	in (loc)	l/defl	L/d	PLATES	GRIP
TCLL 20.0	Plate Grip DOL	1.25	TC 0.45	Vert(LL)	-0.07 18-19	>999	240	MT20	244/190
TCDL 7.0	Lumber DOL	1.25	BC 0.68	Vert(CT)	-0.14 18-19	>999	180		
BCLL 0.0 *	Rep Stress Incr	NO	WB 0.79	Horz(CT)	0.03 14	n/a	n/a		
BCDL 10.0	Code FBC2017/TPI2014		Matrix-MS					Weight: 415 lb	FT = 20%

LUMBER-	BRACING-
TOP CHORD 2x4 SP No.2	TOP CHORD Structural wood sheathing directly applied or 5-3-1 oc purlins, except end verticals, and 2-0-0 oc purlins (6-0-0 max.): 7-9.
BOT CHORD 2x4 SP No.2	BOT CHORD Rigid ceiling directly applied or 9-6-13 oc bracing.
WEBS 2x4 SP No.3 *Except* 12-14: 2x6 SP No.2	WEBS 1 Row at midpt 6-22, 8-22, 8-19
OTHERS 2x4 SP No.3	
SLIDER Left 2x6 SP No.2 1-11-8	

REACTIONS. All bearings 5-5-0 except (jt=length) 2=0-3-8, 24=0-5-8, 17=0-3-8.
 (lb) - Max Horz 2=345(LC 7)
 Max Uplift All uplift 100 lb or less at joint(s) 15 except 2=-202(LC 27), 24=-218(LC 8), 14=-231(LC 9), 16=-301(LC 16), 17=-230(LC 28)
 Max Grav All reactions 250 lb or less at joint(s) 15, 16 except 2=480(LC 19), 24=1259(LC 2), 14=933(LC 2), 17=719(LC 1)

FORCES. (lb) - Max. Comp./Max. Ten. - All forces 250 (lb) or less except when shown.
 TOP CHORD 2-4=-316/205, 4-6=-995/334, 6-7=-1055/344, 7-8=-853/348, 8-9=-788/283,
 9-10=-987/277, 10-12=-706/160, 12-14=-921/221
 BOT CHORD 2-24=-357/358, 23-24=-357/358, 22-23=-329/914, 21-22=-258/913, 19-21=-258/913,
 18-19=-87/568
 WEBS 4-24=-1136/229, 4-23=-25/783, 6-23=-347/54, 7-22=-58/272, 8-19=-392/211,
 9-19=-63/277, 10-19=-167/365, 10-18=-746/224, 12-18=-61/683

- NOTES-**
- Unbalanced roof live loads have been considered for this design.
 - Wind: ASCE 7-10; Vult=130mph (3-second gust) Vasd=101mph; TC DL=4.2psf; BCDL=3.0psf; h=20ft; Cat. II; Exp B; Encl., GCpi=0.18; MWFRS (envelope) gable end zone; end vertical right exposed; porch left exposed; Lumber DOL=1.60 plate grip DOL=1.60
 - Truss designed for wind loads in the plane of the truss only. For studs exposed to wind (normal to the face), see Standard Industry Gable End Details as applicable, or consult qualified building designer as per ANSI/TPI 1.
 - Provide adequate drainage to prevent water ponding.
 - All plates are 2x4 MT20 unless otherwise indicated.
 - Gable studs spaced at 2-0-0 oc.
 - This truss has been designed for a 10.0 psf bottom chord live load nonconcurrent with any other live loads.
 - * This truss has been designed for a live load of 20.0psf on the bottom chord in all areas where a rectangle 3-6-0 tall by 2-0-0 wide will fit between the bottom chord and any other members, with BCDL = 10.0psf.
 - Provide mechanical connection (by others) of truss to bearing plate capable of withstanding 100 lb uplift at joint(s) 15 except (jt=lb) 2=202, 24=218, 14=231, 16=301, 17=230.
 - Graphical purlin representation does not depict the size or the orientation of the purlin along the top and/or bottom chord.
 - Hanger(s) or other connection device(s) shall be provided sufficient to support concentrated load(s) 27 lb down and 38 lb up at 37-2-3, and 27 lb down and 38 lb up at 39-2-3 on bottom chord. The design/selection of such connection device(s) is the responsibility of others.

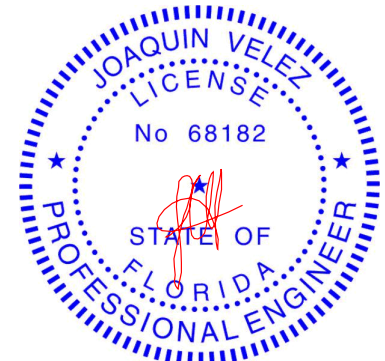

Joaquin Velez PE No.68182
 MiTek USA, Inc. FL Cert 6634
 6904 Parke East Blvd. Tampa FL 33610
 Date:

November 5, 2020

WARNING - Verify design parameters and READ NOTES ON THIS AND INCLUDED MITEK REFERENCE PAGE MII-7473 rev. 5/19/2020 BEFORE USE.

Design valid for use only with MiTek® connectors. This design is based only upon parameters shown, and is for an individual building component, not a truss system. Before use, the building designer must verify the applicability of design parameters and properly incorporate this design into the overall building design. Bracing indicated is to prevent buckling of individual truss web and/or chord members only. Additional temporary and permanent bracing is always required for stability and to prevent collapse with possible personal injury and property damage. For general guidance regarding the fabrication, storage, delivery, erection and bracing of trusses and truss systems, see **ANSI/TPI Quality Criteria, DSB-89 and BCSI Building Component Safety Information** available from Truss Plate Institute, 2670 Crain Highway, Suite 203 Waldorf, MD 20601

6904 Parke East Blvd.
 Tampa, FL 33610

Job 2525538	Truss T07G	Truss Type GABLE	Qty 1	Ply 1	AMIRA BLDRS - THOMAS RES. Job Reference (optional)	T21805045
----------------	---------------	---------------------	----------	----------	---	-----------

Builders FirstSource (Jacksonville, FL), Jacksonville, FL - 32244,

8.240 s Mar 9 2020 MiTek Industries, Inc. Thu Nov 5 09:19:01 2020 Page 2
ID:7Wkr8toudn35dxwKwBAfQtytHta-k?gwfvW3rNKToRIRFNeBjRV4Lyhx0EodlxQIR6yMH4O

NOTES-

12) In the LOAD CASE(S) section, loads applied to the face of the truss are noted as front (F) or back (B).

LOAD CASE(S) Standard

1) Dead + Roof Live (balanced): Lumber Increase=1.25, Plate Increase=1.25

Uniform Loads (plf)

Vert: 1-7=-54, 7-9=-54, 9-12=-54, 12-13=-54, 14-46=-20

Concentrated Loads (lb)

Vert: 53=-22(F) 54=-23(F)

 **WARNING - Verify design parameters and READ NOTES ON THIS AND INCLUDED MITEK REFERENCE PAGE MII-7473 rev. 5/19/2020 BEFORE USE.**

Design valid for use only with MiTek® connectors. This design is based only upon parameters shown, and is for an individual building component, not a truss system. Before use, the building designer must verify the applicability of design parameters and properly incorporate this design into the overall building design. Bracing indicated is to prevent buckling of individual truss web and/or chord members only. Additional temporary and permanent bracing is always required for stability and to prevent collapse with possible personal injury and property damage. For general guidance regarding the fabrication, storage, delivery, erection and bracing of trusses and truss systems, see **ANSI/TPI1 Quality Criteria, DSB-89 and BCSI Building Component Safety Information** available from Truss Plate Institute, 2670 Crain Highway, Suite 203 Waldorf, MD 20601



6904 Parke East Blvd.
Tampa, FL 36610

Job 2525538	Truss T08	Truss Type Piggyback Base	Qty 1	Ply 1	AMIRA BLDRS - THOMAS RES.	T21805046
----------------	--------------	------------------------------	----------	----------	---------------------------	-----------

Builders FirstSource (Jacksonville, FL), Jacksonville, FL - 32244, 8.240 s Mar 9 2020 MiTek Industries, Inc. Thu Nov 5 09:19:03 2020 Page 1

ID:7Wkr8toudn35dxwKwBAfQtytHta-hOng4bXKM_aB2lSqNogfosbSHmPRUCpwIEvsW?yMH4M

1-6-0	6-8-12	11-9-11	18-0-12	23-4-2	28-7-8	30-8-0	34-3-12	37-10-8	40-3-8	41-10-0
1-6-0	6-8-12	5-0-15	6-3-1	5-3-6	5-3-6	2-0-8	3-7-12	3-6-12	2-5-0	1-6-8

Scale = 1:80.6

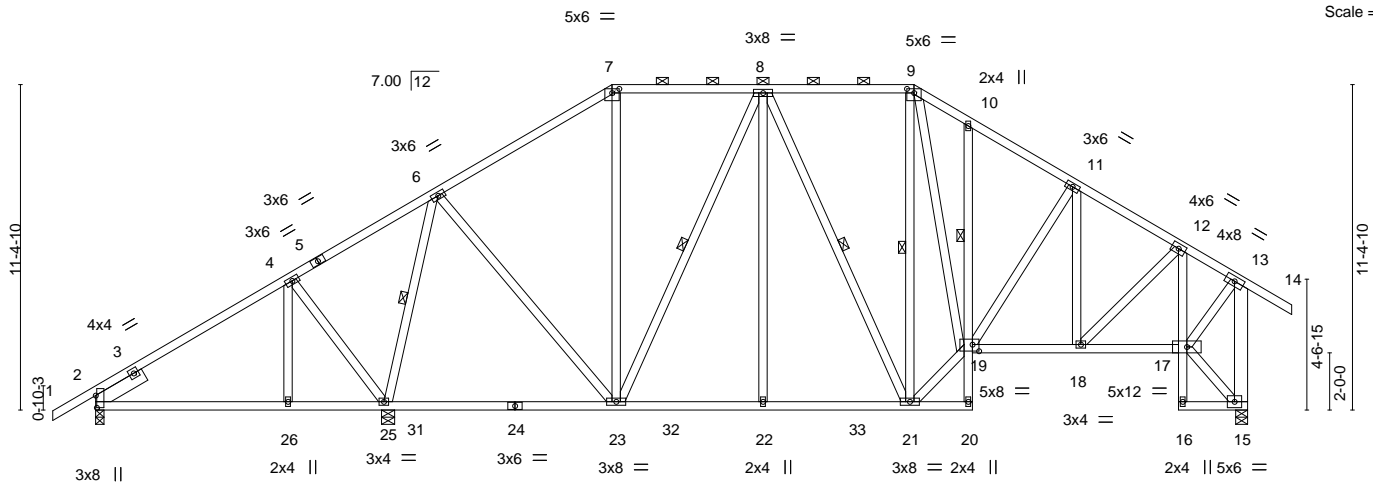

6-8-12	10-2-12	18-0-12	23-4-2	28-7-8	30-8-0	34-3-12	37-10-8	40-3-8
6-8-12	3-6-0	7-10-0	5-3-6	5-3-6	2-0-8	3-7-12	3-6-12	2-5-0

LOADING (psf)	SPACING-	2-0-0	CSI.	DEFL.	in (loc)	l/defl	L/d	PLATES	GRIP
TCLL 20.0	Plate Grip DOL	1.25	TC 0.36	Vert(LL)	-0.10 23-25	>999	240	MT20	244/190
TCDL 7.0	Lumber DOL	1.25	BC 0.49	Vert(CT)	-0.20 23-25	>999	180		
BCLL 0.0 *	Rep Stress Incr	YES	WB 0.53	Horz(CT)	0.08 15	n/a	n/a		
BCDL 10.0	Code FBC2017/TPI2014		Matrix-MS					Weight: 343 lb	FT = 20%

LUMBER-	BRACING-
TOP CHORD 2x4 SP No.2	TOP CHORD Structural wood sheathing directly applied or 5-6-1 oc purlins, except end verticals, and 2-0-0 oc purlins (6-0-0 max.): 7-9.
BOT CHORD 2x4 SP No.2 *Except* 10-20,12-16: 2x4 SP No.3	BOT CHORD Rigid ceiling directly applied or 10-0-0 oc bracing, Except: 9-4-6 oc bracing: 2-26 9-5-7 oc bracing: 25-26 6-0-0 oc bracing: 19-20.
WEBS 2x4 SP No.3 *Except* 13-15: 2x6 SP No.2	WEBS 1 Row at midpt 10-19 1 Row at midpt 6-25, 8-23, 8-21, 9-21
SLIDER Left 2x6 SP No.2 1-11-8	

REACTIONS. (size) 2=0-3-8, 25=0-5-8, 15=0-5-0
 Max Horz 2=349(LC 11)
 Max Uplift 2=193(LC 12), 25=274(LC 12), 15=296(LC 13)
 Max Grav 2=508(LC 23), 25=1461(LC 2), 15=1212(LC 1)

FORCES. (lb) - Max. Comp./Max. Ten. - All forces 250 (lb) or less except when shown.
 TOP CHORD 2-4=-382/382, 4-6=-269/257, 6-7=-802/453, 7-8=-662/442, 8-9=-726/457,
 9-10=-1061/553, 10-11=-1107/493, 11-12=-1095/431, 12-13=-698/277, 13-15=-1177/477
 BOT CHORD 2-26=-359/380, 25-26=-359/380, 23-25=-250/401, 22-23=-241/786, 21-22=-241/786,
 18-19=-296/907, 17-18=-217/581, 12-17=-638/221
 WEBS 4-25=-368/388, 6-25=-1057/279, 6-23=-117/573, 8-23=-428/193, 8-22=0/265,
 9-21=-500/144, 19-21=-258/993, 9-19=-323/850, 13-17=-291/887, 12-18=-111/453

- NOTES-**
- Unbalanced roof live loads have been considered for this design.
 - Wind: ASCE 7-10; Vult=130mph (3-second gust) Vasd=101mph; TC DL=4.2psf; BCDL=3.0psf; h=20ft; Cat. II; Exp B; Encl., GCpi=0.18; MWFRS (envelope) gable end zone and C-C Exterior(2) zone; end vertical right exposed; porch left exposed; C-C for members and forces & MWFRS for reactions shown; Lumber DOL=1.60 plate grip DOL=1.60
 - Provide adequate drainage to prevent water ponding.
 - This truss has been designed for a 10.0 psf bottom chord live load nonconcurrent with any other live loads.
 - * This truss has been designed for a live load of 20.0psf on the bottom chord in all areas where a rectangle 3-6-0 tall by 2-0-0 wide will fit between the bottom chord and any other members, with BCDL = 10.0psf.
 - Provide mechanical connection (by others) of truss to bearing plate capable of withstanding 100 lb uplift at joint(s) except (it=lb) 2=193, 25=274, 15=296.
 - Graphical purlin representation does not depict the size or the orientation of the purlin along the top and/or bottom chord.

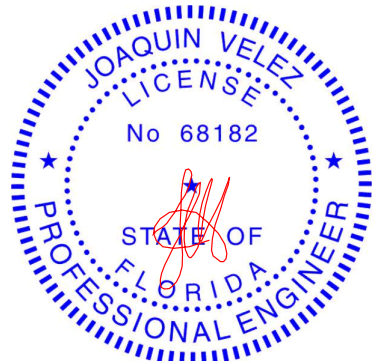

Joaquin Velez PE No.68182
 MiTek USA, Inc. FL Cert 6634
 6904 Parke East Blvd. Tampa FL 33610
 Date:

November 5, 2020

Job 2525538	Truss T09	Truss Type Piggyback Base	Qty 3	Ply 1	AMIRA BLDRS - THOMAS RES. Job Reference (optional)	T21805047
----------------	--------------	------------------------------	----------	----------	---	-----------

Builders FirstSource (Jacksonville, FL), Jacksonville, FL - 32244,

8.240 s Mar 9 2020 MiTek Industries, Inc. Thu Nov 5 09:19:05 2020 Page 1

ID:7Wkr8toudn35dxwKwBAfQtytHta-dmvQVHZaubqvH2cCUDI7tHggnZ5vy5sDCYOzatyMH4K

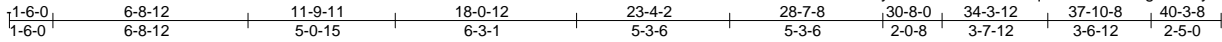

Scale = 1:79.5

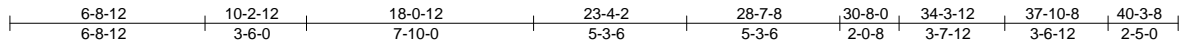
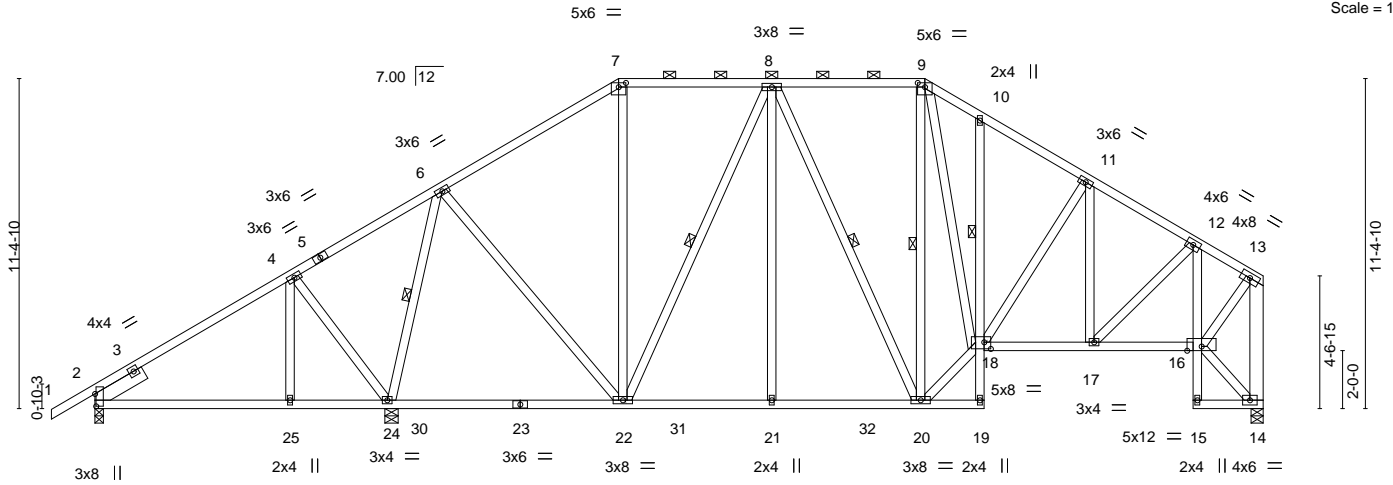

Plate Offsets (X,Y)-- [2:0-5-2,0-0-7], [7:0-3-0,0-1-12], [9:0-3-0,0-1-12], [18:0-2-12,0-2-12]

LOADING (psf)	SPACING-	2-0-0	CSI.	DEFL.	in (loc)	l/defl	L/d	PLATES	GRIP
TCLL 20.0	Plate Grip DOL	1.25	TC 0.36	Vert(LL)	-0.10 22-24	>999	240	MT20	244/190
TCDL 7.0	Lumber DOL	1.25	BC 0.49	Vert(CT)	-0.20 22-24	>999	180		
BCLL 0.0 *	Rep Stress Incr	YES	WB 0.59	Horz(CT)	0.08 14	n/a	n/a		
BCDL 10.0	Code FBC2017/TPI2014		Matrix-MS					Weight: 340 lb	FT = 20%

LUMBER-
TOP CHORD 2x4 SP No.2
BOT CHORD 2x4 SP No.2 *Except*
 10-19,12-15: 2x4 SP No.3
WEBS 2x4 SP No.3 *Except*
 13-14: 2x6 SP No.2
SLIDER Left 2x6 SP No.2 1-11-8

BRACING-
TOP CHORD Structural wood sheathing directly applied or 5-5-12 oc purlins, except end verticals, and 2-0-0 oc purlins (6-0-0 max.): 7-9.
BOT CHORD Rigid ceiling directly applied or 10-0-0 oc bracing, Except:
 8-10-10 oc bracing: 2-25
 8-11-11 oc bracing: 24-25
 6-0-0 oc bracing: 18-19.
 1 Row at midpt 10-18
WEBS 1 Row at midpt 6-24, 8-22, 8-20, 9-20

REACTIONS. (size) 2=0-3-8, 24=0-5-8, 14=0-5-0
 Max Horz 2=340(LC 11)
 Max Uplift 2=190(LC 12), 24=277(LC 12), 14=253(LC 13)
 Max Grav 2=508(LC 23), 24=1463(LC 2), 14=1114(LC 1)

FORCES. (lb) - Max. Comp./Max. Ten. - All forces 250 (lb) or less except when shown.
TOP CHORD 2-4=-372/371, 4-6=-259/244, 6-7=-804/445, 7-8=-657/435, 8-9=-727/450,
 9-10=-1069/550, 10-11=-1115/490, 11-12=-1110/427, 12-13=-713/262, 13-14=-1087/405
BOT CHORD 2-25=-398/369, 24-25=-398/369, 22-24=-257/392, 21-22=-268/789, 20-21=-268/789,
 17-18=-348/919, 16-17=-267/605, 12-16=-648/254
WEBS 4-24=-368/391, 6-24=-1060/290, 6-22=-119/573, 8-22=-431/192, 8-21=0/265,
 9-20=-507/186, 18-20=-319/998, 9-18=-364/862, 12-17=-113/436, 13-16=-350/911

- NOTES-**
- Unbalanced roof live loads have been considered for this design.
 - Wind: ASCE 7-10; Vult=130mph (3-second gust) Vasd=101mph; TC DL=4.2psf; BCDL=3.0psf; h=20ft; Cat. II; Exp B; Encl., GCpi=0.18; MWFRS (envelope) gable end zone and C-C Exterior(2) zone; end vertical right exposed; porch left exposed; C-C for members and forces & MWFRS for reactions shown; Lumber DOL=1.60 plate grip DOL=1.60
 - Provide adequate drainage to prevent water ponding.
 - This truss has been designed for a 10.0 psf bottom chord live load nonconcurrent with any other live loads.
 - * This truss has been designed for a live load of 20.0psf on the bottom chord in all areas where a rectangle 3-6-0 tall by 2-0-0 wide will fit between the bottom chord and any other members, with BCDL = 10.0psf.
 - Provide mechanical connection (by others) of truss to bearing plate capable of withstanding 100 lb uplift at joint(s) except (it=lb) 2=190, 24=277, 14=253.
 - Graphical purlin representation does not depict the size or the orientation of the purlin along the top and/or bottom chord.

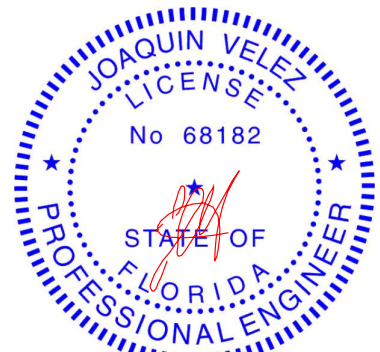

Joaquin Velez PE No.68182
 MiTek USA, Inc. FL Cert 6634
 6904 Parke East Blvd. Tampa FL 33610
 Date:

November 5, 2020

WARNING - Verify design parameters and READ NOTES ON THIS AND INCLUDED MITEK REFERENCE PAGE MII-7473 rev. 5/19/2020 BEFORE USE.

Design valid for use only with MiTek® connectors. This design is based only upon parameters shown, and is for an individual building component, not a truss system. Before use, the building designer must verify the applicability of design parameters and properly incorporate this design into the overall building design. Bracing indicated is to prevent buckling of individual truss web and/or chord members only. Additional temporary and permanent bracing is always required for stability and to prevent collapse with possible personal injury and property damage. For general guidance regarding the fabrication, storage, delivery, erection and bracing of trusses and truss systems, see **ANSI/TPI1 Quality Criteria, DSB-89 and BCSI Building Component Safety Information** available from Truss Plate Institute, 2670 Crain Highway, Suite 203 Waldorf, MD 20601



6904 Parke East Blvd.
 Tampa, FL 33610

Job 2525538	Truss T10	Truss Type Piggyback Base	Qty 1	Ply 1	AMIRA BLDRS - THOMAS RES. Job Reference (optional)	T21805048
----------------	--------------	------------------------------	----------	----------	---	-----------

Builders FirstSource (Jacksonville, FL), Jacksonville, FL - 32244, 8.240 s Mar 9 2020 MiTek Industries, Inc. Thu Nov 5 09:19:07 2020 Page 1
 ID:7Wkr8toudn35dxwKwBAfQtytHta-Z91BwyqQD5dWMIbcelbyiI7HNn9Q1OWgst4fmyMH41

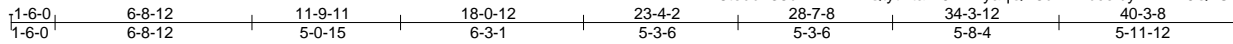

Scale = 1:78.7

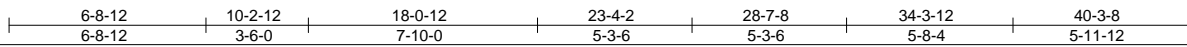
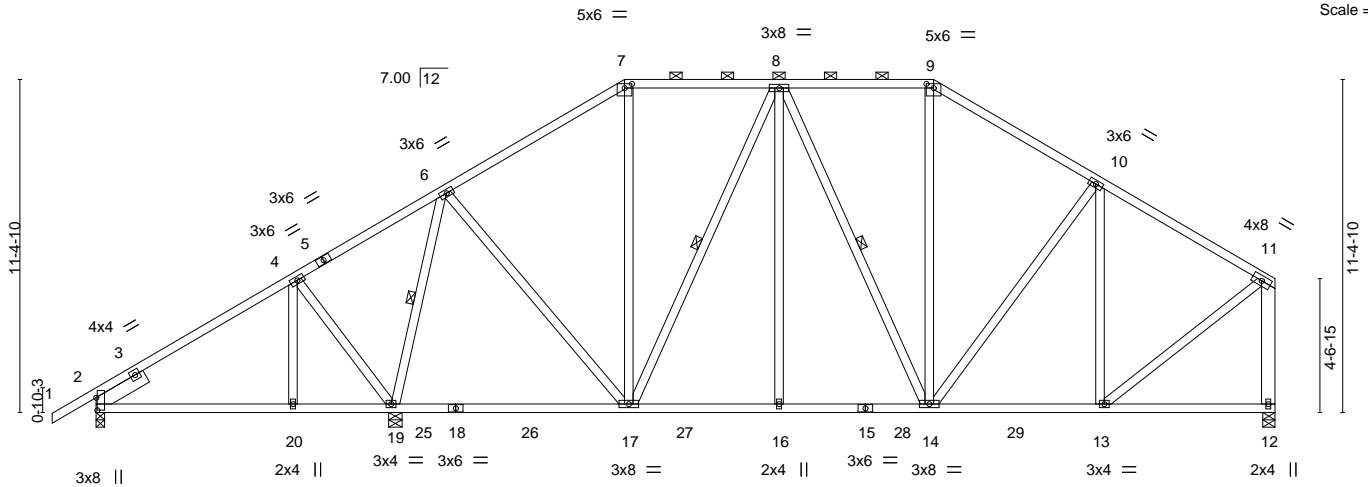

LOADING (psf)	SPACING-	2-0-0	CSI.	DEFL.	in (loc)	l/defl	L/d	PLATES	GRIP
TCLL 20.0	Plate Grip DOL	1.25	TC 0.36	Vert(LL)	-0.11 17-19	>999	240	MT20	244/190
TCDL 7.0	Lumber DOL	1.25	BC 0.50	Vert(CT)	-0.20 17-19	>999	180		
BCLL 0.0 *	Rep Stress Incr	YES	WB 0.46	Horz(CT)	0.03 12	n/a	n/a		
BCDL 10.0	Code FBC2017/TPI2014		Matrix-MS					Weight: 302 lb	FT = 20%

LUMBER-	BRACING-
TOP CHORD 2x4 SP No.2	TOP CHORD Structural wood sheathing directly applied or 5-8-9 oc purlins, except end verticals, and 2-0-0 oc purlins (6-0-0 max.): 7-9.
BOT CHORD 2x4 SP No.2	BOT CHORD Rigid ceiling directly applied or 10-0-0 oc bracing, Except:
WEBS 2x4 SP No.3 *Except*	8-8-11 oc bracing: 2-20
11-12: 2x6 SP No.2	8-9-10 oc bracing: 19-20.
SLIDER Left 2x6 SP No.2 1-11-8	WEBS 1 Row at midpt 6-19, 8-17, 8-14

REACTIONS. (size) 2=0-3-8, 19=0-5-8, 12=0-5-0
 Max Horz 2=340(LC 11)
 Max Uplift 2=191(LC 12), 19=-275(LC 12), 12=-256(LC 13)
 Max Grav 2=527(LC 23), 19=1454(LC 2), 12=1132(LC 2)

FORCES. (lb) - Max. Comp./Max. Ten. - All forces 250 (lb) or less except when shown.
 TOP CHORD 2-4=-404/379, 4-6=-292/253, 6-7=-843/449, 7-8=-670/439, 8-9=-773/452,
 9-10=-964/473, 10-11=-905/370, 11-12=-1085/389
 BOT CHORD 2-20=-416/402, 19-20=-416/402, 17-19=-260/426, 16-17=-274/827, 14-16=-274/827,
 13-14=-271/733
 WEBS 4-19=-362/388, 6-19=-1031/275, 6-17=-119/569, 8-17=-442/192, 8-16=0/258,
 10-13=-401/212, 11-13=-284/899

- NOTES-**
- 1) Unbalanced roof live loads have been considered for this design.
 - 2) Wind: ASCE 7-10; Vult=130mph (3-second gust) Vasd=101mph; TC DL=4.2psf; BCDL=3.0psf; h=20ft; Cat. II; Exp B; Encl., GCpi=0.18; MWFRS (envelope) gable end zone and C-C Exterior(2) zone; end vertical right exposed; porch left exposed; C-C for members and forces & MWFRS for reactions shown; Lumber DOL=1.60 plate grip DOL=1.60
 - 3) Provide adequate drainage to prevent water ponding.
 - 4) This truss has been designed for a 10.0 psf bottom chord live load nonconcurrent with any other live loads.
 - 5) * This truss has been designed for a live load of 20.0psf on the bottom chord in all areas where a rectangle 3-6-0 tall by 2-0-0 wide will fit between the bottom chord and any other members, with BCDL = 10.0psf.
 - 6) Provide mechanical connection (by others) of truss to bearing plate capable of withstanding 100 lb uplift at joint(s) except (jt=lb) 2=191, 19=275, 12=256.
 - 7) Graphical purlin representation does not depict the size or the orientation of the purlin along the top and/or bottom chord.

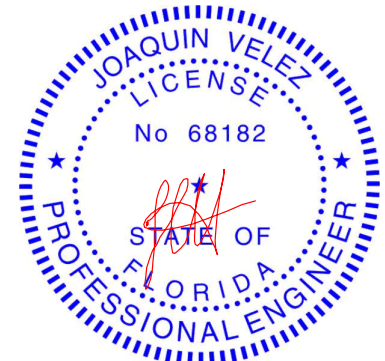

Joaquin Velez PE No.68182
 MiTek USA, Inc. FL Cert 6634
 6904 Parke East Blvd. Tampa FL 33610
 Date:

November 5, 2020

WARNING - Verify design parameters and READ NOTES ON THIS AND INCLUDED MITEK REFERENCE PAGE MII-7473 rev. 5/19/2020 BEFORE USE.
 Design valid for use only with MiTek® connectors. This design is based only upon parameters shown, and is for an individual building component, not a truss system. Before use, the building designer must verify the applicability of design parameters and properly incorporate this design into the overall building design. Bracing indicated is to prevent buckling of individual truss web and/or chord members only. Additional temporary and permanent bracing is always required for stability and to prevent collapse with possible personal injury and property damage. For general guidance regarding the fabrication, storage, delivery, erection and bracing of trusses and truss systems, see **ANSI/TPI1 Quality Criteria, DSB-89 and BCSI Building Component Safety Information** available from Truss Plate Institute, 2670 Crain Highway, Suite 203 Waldorf, MD 20601



Job 2525538	Truss T11	Truss Type Piggyback Base	Qty 4	Ply 1	AMIRA BLDRS - THOMAS RES. T21805049
----------------	--------------	------------------------------	----------	----------	--

Builders FirstSource (Jacksonville, FL), Jacksonville, FL - 32244,

8.240 s Mar 9 2020 MiTek Industries, Inc. Thu Nov 5 09:19:08 2020 Page 1

ID:7WKr8toudn35dxwKwBAfQytHta-1LbZ7lbSBWU8WKnALGqVvII3n7g9SnfvWcdBCyMH4H

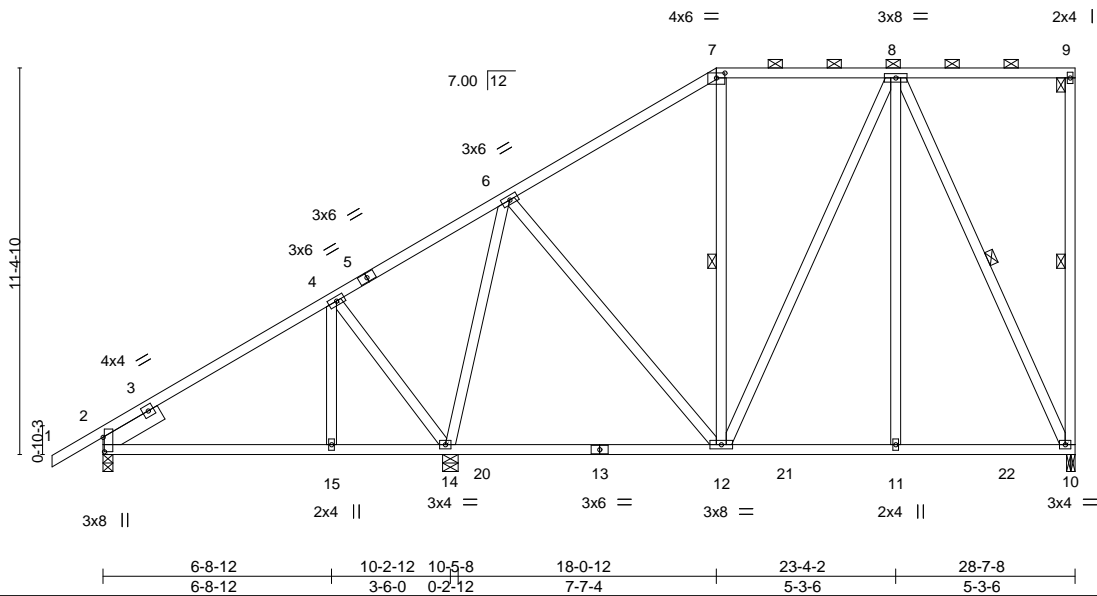
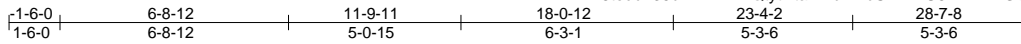

Scale = 1:67.8

Plate Offsets (X,Y)--	[2:0-5-2,0-0-7], [7:0-3-0,0-1-12]				
LOADING (psf)	SPACING- 2-0-0	CSI.	DEFL. in (loc) l/defl L/d	PLATES	GRIP
TCLL 20.0	Plate Grip DOL 1.25	TC 0.36	Vert(LL) -0.10 12-14 >999 240	MT20	244/190
TCDL 7.0	Lumber DOL 1.25	BC 0.49	Vert(CT) -0.19 12-14 >999 180		
BCLL 0.0 *	Rep Stress Incr YES	WB 0.58	Horz(CT) 0.02 2 n/a n/a		
BCDL 10.0	Code FBC2017/TPI2014	Matrix-MS			
				Weight: 219 lb	FT = 20%

LUMBER-	BRACING-
TOP CHORD 2x4 SP No.2	TOP CHORD Structural wood sheathing directly applied or 6-0-0 oc purlins, except end verticals, and 2-0-0 oc purlins (6-0-0 max.): 7-9.
BOT CHORD 2x4 SP No.2	BOT CHORD Rigid ceiling directly applied or 7-4-3 oc bracing.
WEBS 2x4 SP No.3	WEBS 1 Row at midpt 9-10, 7-12, 8-10
SLIDER Left 2x6 SP No.2 1-11-8	

REACTIONS. (size) 10=0-3-0, 2=0-3-8, 14=0-5-8
 Max Horz 2=437(LC 12)
 Max Uplift 10=-268(LC 9), 2=-148(LC 12), 14=-186(LC 12)
 Max Grav 10=783(LC 2), 2=552(LC 1), 14=934(LC 2)

FORCES. (lb) - Max. Comp./Max. Ten. - All forces 250 (lb) or less except when shown.
 TOP CHORD 2-4=-428/316, 6-7=-480/191, 7-8=-348/215
 BOT CHORD 2-15=-577/550, 14-15=-577/550, 12-14=-327/388, 11-12=-143/291, 10-11=-143/291
 WEBS 4-14=-359/425, 6-14=-524/64, 8-12=-178/261, 8-11=0/287, 8-10=-685/338

- NOTES-**
- 1) Wind: ASCE 7-10; Vult=130mph (3-second gust) Vasd=101mph; TC DL=4.2psf; BCDL=3.0psf; h=20ft; Cat. II; Exp B; Encl., GCpi=0.18; MWFRS (envelope) gable end zone and C-C Exterior(2) zone; porch left exposed; C-C for members and forces & MWFRS for reactions shown; Lumber DOL=1.60 plate grip DOL=1.60
 - 2) Provide adequate drainage to prevent water ponding.
 - 3) This truss has been designed for a 10.0 psf bottom chord live load nonconcurrent with any other live loads.
 - 4) * This truss has been designed for a live load of 20.0psf on the bottom chord in all areas where a rectangle 3-6-0 tall by 2-0-0 wide will fit between the bottom chord and any other members, with BCDL = 10.0psf.
 - 5) Provide mechanical connection (by others) of truss to bearing plate capable of withstanding 100 lb uplift at joint(s) except (jt=lb) 10=268, 2=148, 14=186.
 - 6) Graphical purlin representation does not depict the size or the orientation of the purlin along the top and/or bottom chord.

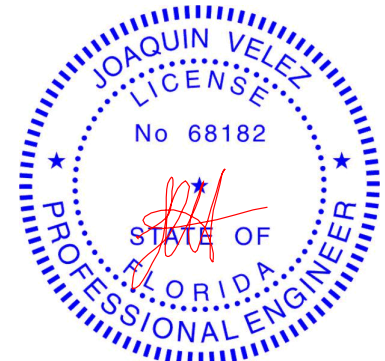

Joaquin Velez PE No.68182
 MiTek USA, Inc. FL Cert 6634
 6904 Parke East Blvd. Tampa FL 33610
 Date:

November 5, 2020

Job 2525538	Truss T12	Truss Type Piggyback Base	Qty 2	Ply 1	AMIRA BLDRS - THOMAS RES. Job Reference (optional)	T21805050
----------------	--------------	------------------------------	----------	----------	---	-----------

Builders FirstSource (Jacksonville, FL), Jacksonville, FL - 32244,

8.240 s Mar 9 2020 MiTek Industries, Inc. Thu Nov 5 09:19:10 2020 Page 1

ID:7WKr8toudn35dxwKwBAfQtYtHta_kiJY_djj8TBNqUAHmlaKNeGaiWdOWyMq6kG5yMH4F

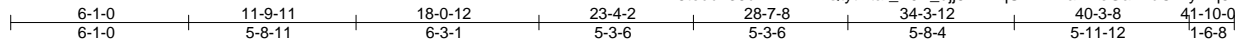

Scale = 1:78.8

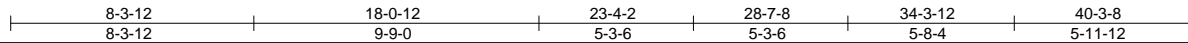
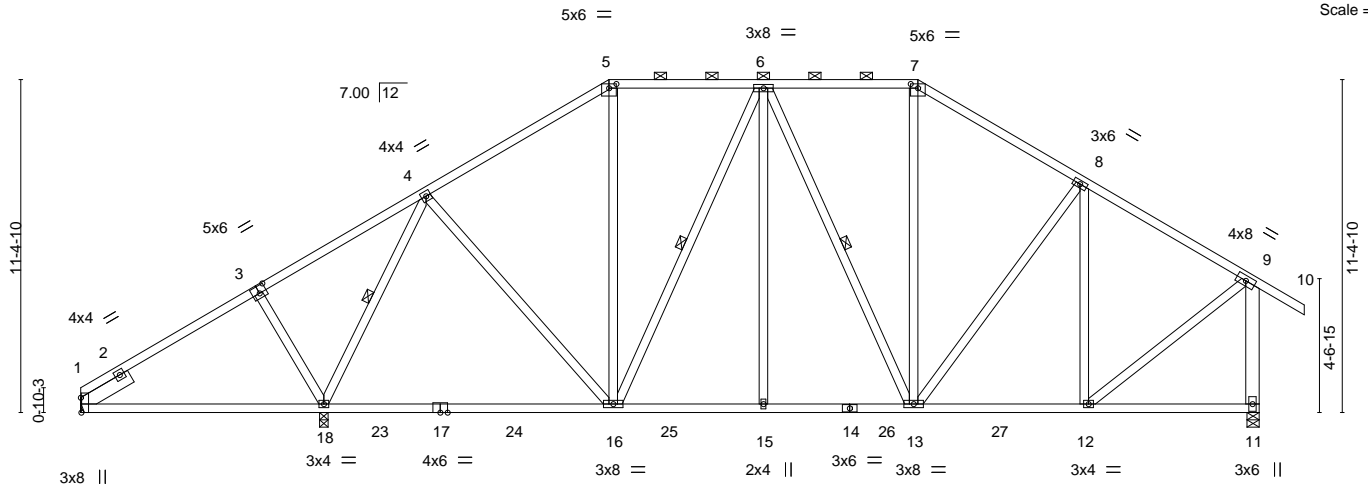

Plate Offsets (X, Y)-- [1:0-6-2,Edge], [3:0-3-0,0-3-0], [5:0-3-0,0-1-12], [7:0-3-0,0-1-12]

LOADING (psf)	SPACING-	2-0-0	CSI.	DEFL.	in (loc)	l/defl	L/d	PLATES	GRIP
TCLL 20.0	Plate Grip DOL	1.25	TC 0.38	Vert(LL)	-0.31 16-18	>999	240	MT20	244/190
TCDL 7.0	Lumber DOL	1.25	BC 0.85	Vert(CT)	-0.49 16-18	>774	180		
BCLL 0.0 *	Rep Stress Incr	YES	WB 0.50	Horz(CT)	0.03 11	n/a	n/a		
BCDL 10.0	Code	FBC2017/TPI2014	Matrix-MS					Weight: 295 lb	FT = 20%

LUMBER-
 TOP CHORD 2x4 SP No.2
 BOT CHORD 2x4 SP No.2
 WEBS 2x4 SP No.3 *Except*
 9-11: 2x6 SP No.2
 SLIDER Left 2x6 SP No.2 1-11-8

BRACING-
 TOP CHORD Structural wood sheathing directly applied or 5-3-6 oc purlins, except end verticals, and 2-0-0 oc purlins (6-0-0 max.): 5-7.
 BOT CHORD Rigid ceiling directly applied or 10-0-0 oc bracing.
 WEBS 1 Row at midpt 4-18, 6-16, 6-13

REACTIONS. (size) 1=Mechanical, 18=0-3-8, 11=0-5-0
 Max Horz 1=334(LC 11)
 Max Uplift 1=130(LC 12), 18=290(LC 12), 11=306(LC 13)
 Max Grav 1=385(LC 23), 18=1517(LC 2), 11=1291(LC 1)

FORCES. (lb) - Max. Comp./Max. Ten. - All forces 250 (lb) or less except when shown.
 TOP CHORD 1-3=-391/182, 3-4=-314/210, 4-5=-996/473, 5-6=-797/459, 6-7=-836/468,
 7-8=-1035/489, 8-9=-955/393, 9-11=-1238/479
 BOT CHORD 1-18=-255/399, 16-18=-265/660, 15-16=-247/918, 13-15=-247/918, 12-13=-235/771
 WEBS 3-18=-300/219, 4-18=-1124/325, 4-16=-128/469, 5-16=-76/258, 6-16=-358/200,
 6-13=-273/181, 7-13=-95/283, 8-12=-435/193, 9-12=-253/951

- NOTES-**
- Unbalanced roof live loads have been considered for this design.
 - Wind: ASCE 7-10; Vult=130mph (3-second gust) Vasd=101mph; TCDL=4.2psf; BCDL=3.0psf; h=20ft; Cat. II; Exp B; Encl., GCpi=0.18; MWFRS (envelope) gable end zone and C-C Exterior(2) zone; end vertical right exposed; C-C for members and forces & MWFRS for reactions shown; Lumber DOL=1.60 plate grip DOL=1.60
 - Provide adequate drainage to prevent water ponding.
 - This truss has been designed for a 10.0 psf bottom chord live load nonconcurrent with any other live loads.
 - * This truss has been designed for a live load of 20.0psf on the bottom chord in all areas where a rectangle 3-6-0 tall by 2-0-0 wide will fit between the bottom chord and any other members, with BCDL = 10.0psf.
 - Refer to girder(s) for truss to truss connections.
 - Provide mechanical connection (by others) of truss to bearing plate capable of withstanding 100 lb uplift at joint(s) except (jt=lb) 1=130, 18=290, 11=306.
 - Graphical purlin representation does not depict the size or the orientation of the purlin along the top and/or bottom chord.

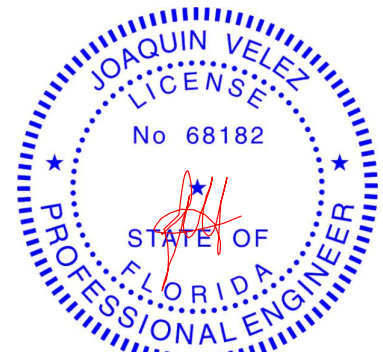

Joaquin Velez PE No.68182
 MiTek USA, Inc. FL Cert 6634
 6904 Parke East Blvd. Tampa FL 33610
 Date:

November 5, 2020

WARNING - Verify design parameters and READ NOTES ON THIS AND INCLUDED MITEK REFERENCE PAGE MII-7473 rev. 5/19/2020 BEFORE USE.

Design valid for use only with MiTek® connectors. This design is based only upon parameters shown, and is for an individual building component, not a truss system. Before use, the building designer must verify the applicability of design parameters and properly incorporate this design into the overall building design. Bracing indicated is to prevent buckling of individual truss web and/or chord members only. Additional temporary and permanent bracing is always required for stability and to prevent collapse with possible personal injury and property damage. For general guidance regarding the fabrication, storage, delivery, erection and bracing of trusses and truss systems, see **ANSI/TPI1 Quality Criteria, DSB-89 and BCSI Building Component Safety Information** available from Truss Plate Institute, 2670 Crain Highway, Suite 203 Waldorf, MD 20601



6904 Parke East Blvd.
 Tampa, FL 33610

Job 2525538	Truss T12G	Truss Type GABLE	Qty 1	Ply 1	AMIRA BLDRS - THOMAS RES. T21805051 Job Reference (optional)
----------------	---------------	---------------------	----------	----------	--

Builders FirstSource (Jacksonville, FL), Jacksonville, FL - 32244,

8.240 s Mar 9 2020 MiTek Industries, Inc. Thu Nov 5 09:19:13 2020 Page 2
ID:7WKr8toudn35dxwKwBAfQtytHta-OJOSA0fb03rmEHDlyur?Cz?8Soj6qngO2oKOfPyMH4C

LOAD CASE(S) Standard

- 1) Dead + Roof Live (balanced): Lumber Increase=1.25, Plate Increase=1.25
Uniform Loads (plf)
Vert: 1-6=-54, 6-8=-54, 8-11=-54, 11-12=-54, 13-46=-20
Concentrated Loads (lb)
Vert: 54=-22(B) 55=-22(B) 56=-22(B) 57=-23(B)

 **WARNING - Verify design parameters and READ NOTES ON THIS AND INCLUDED MITEK REFERENCE PAGE MII-7473 rev. 5/19/2020 BEFORE USE.**

Design valid for use only with MiTek® connectors. This design is based only upon parameters shown, and is for an individual building component, not a truss system. Before use, the building designer must verify the applicability of design parameters and properly incorporate this design into the overall building design. Bracing indicated is to prevent buckling of individual truss web and/or chord members only. Additional temporary and permanent bracing is always required for stability and to prevent collapse with possible personal injury and property damage. For general guidance regarding the fabrication, storage, delivery, erection and bracing of trusses and truss systems, see **ANSI/TPI1 Quality Criteria, DSB-89 and BCSI Building Component Safety Information** available from Truss Plate Institute, 2670 Crain Highway, Suite 203 Waldorf, MD 20601



6904 Parke East Blvd.
Tampa, FL 36610

Job 2525538	Truss T13	Truss Type Piggyback Base	Qty 4	Ply 1	AMIRA BLDRS - THOMAS RES. Job Reference (optional)	T21805052
----------------	--------------	------------------------------	----------	----------	---	-----------

Builders FirstSource (Jacksonville, FL), Jacksonville, FL - 32244,

8.240 s Mar 9 2020 MiTek Industries, Inc. Thu Nov 5 09:19:15 2020 Page 1

ID:7WKr8toudn35dxwKwBAfQtytHta-KhWCbhhYg5UUbN74JuTHO5V?bQhlfhW6pVxlyMH4A

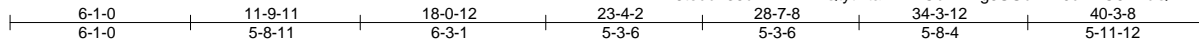

Scale = 1:77.7

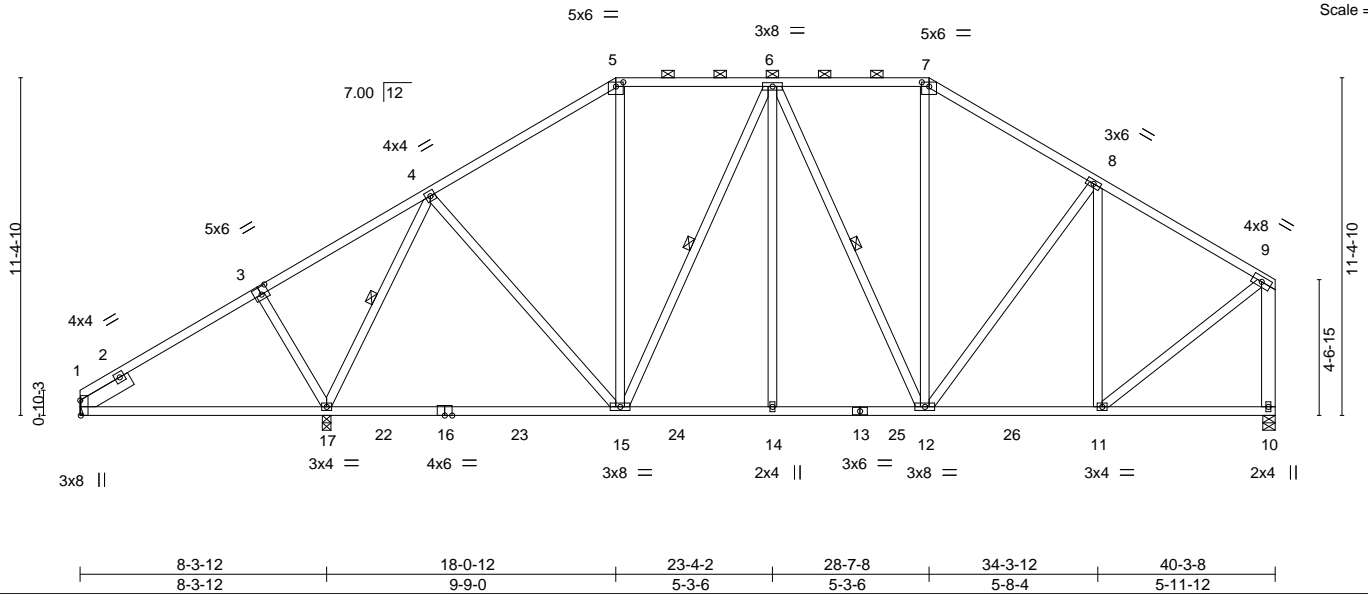

Plate Offsets (X,Y)--	[1:0-6-2,Edge], [3:0-3-0,0-3-0], [5:0-3-0,0-1-12], [7:0-3-0,0-1-12]							
LOADING (psf)	SPACING- 2-0-0	CSI.	DEFL.	in (loc)	l/defl	L/d	PLATES	GRIP
TCLL 20.0	Plate Grip DOL 1.25	TC 0.38	Vert(LL) -0.31	15-17	>999	240	MT20	244/190
TCDL 7.0	Lumber DOL 1.25	BC 0.85	Vert(CT) -0.49	15-17	>774	180		
BCLL 0.0 *	Rep Stress Incr YES	WB 0.51	Horz(CT) 0.04	10	n/a	n/a		
BCDL 10.0	Code FBC2017/TPI2014	Matrix-MS					Weight: 293 lb	FT = 20%

LUMBER-
 TOP CHORD 2x4 SP No.2
 BOT CHORD 2x4 SP No.2
 WEBS 2x4 SP No.3 *Except*
 9-10: 2x6 SP No.2
 SLIDER Left 2x6 SP No.2 1-11-8

BRACING-
 TOP CHORD Structural wood sheathing directly applied or 5-3-4 oc purlins, except end verticals, and 2-0-0 oc purlins (6-0-0 max.): 5-7.
 BOT CHORD Rigid ceiling directly applied or 10-0-0 oc bracing.
 WEBS 1 Row at midpt 4-17, 6-15, 6-12

REACTIONS. (size) 1=Mechanical, 17=0-3-8, 10=0-5-0
 Max Horz 1=326(LC 11)
 Max Uplift 1=127(LC 12), 17=-292(LC 12), 10=-263(LC 13)
 Max Grav 1=385(LC 23), 17=1519(LC 2), 10=1196(LC 2)

FORCES. (lb) - Max. Comp./Max. Ten. - All forces 250 (lb) or less except when shown.
 TOP CHORD 1-3=-391/172, 3-4=-307/200, 4-5=-998/467, 5-6=-799/453, 6-7=-840/461,
 7-8=-1041/483, 8-9=-959/377, 9-10=-1148/397
 BOT CHORD 1-17=-263/384, 15-17=-274/651, 14-15=-286/921, 12-14=-286/921, 11-12=-277/780
 WEBS 3-17=-300/219, 4-17=-1126/332, 4-15=-129/470, 5-15=-73/258, 6-15=-361/199,
 6-12=-273/182, 7-12=-94/285, 8-11=-440/216, 9-11=-291/958

NOTES-

- Unbalanced roof live loads have been considered for this design.
- Wind: ASCE 7-10; Vult=130mph (3-second gust) Vasd=101mph; TCDL=4.2psf; BCDL=3.0psf; h=20ft; Cat. II; Exp B; Encl., GCpi=0.18; MWFRS (envelope) gable end zone and C-C Exterior(2) zone; end vertical right exposed; C-C for members and forces & MWFRS for reactions shown; Lumber DOL=1.60 plate grip DOL=1.60
- Provide adequate drainage to prevent water ponding.
- This truss has been designed for a 10.0 psf bottom chord live load nonconcurrent with any other live loads.
- * This truss has been designed for a live load of 20.0psf on the bottom chord in all areas where a rectangle 3-6-0 tall by 2-0-0 wide will fit between the bottom chord and any other members, with BCDL = 10.0psf.
- Refer to girder(s) for truss to truss connections.
- Provide mechanical connection (by others) of truss to bearing plate capable of withstanding 100 lb uplift at joint(s) except (jt=lb) 1=127, 17=292, 10=263.
- Graphical purlin representation does not depict the size or the orientation of the purlin along the top and/or bottom chord.

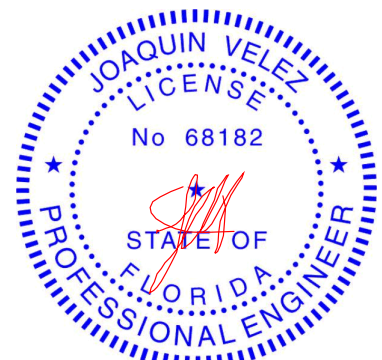

Joaquin Velez PE No.68182
 MiTek USA, Inc. FL Cert 6634
 6904 Parke East Blvd. Tampa FL 33610
 Date:

November 5, 2020

WARNING - Verify design parameters and READ NOTES ON THIS AND INCLUDED MITEK REFERENCE PAGE MII-7473 rev. 5/19/2020 BEFORE USE.

Design valid for use only with MiTek® connectors. This design is based only upon parameters shown, and is for an individual building component, not a truss system. Before use, the building designer must verify the applicability of design parameters and properly incorporate this design into the overall building design. Bracing indicated is to prevent buckling of individual truss web and/or chord members only. Additional temporary and permanent bracing is always required for stability and to prevent collapse with possible personal injury and property damage. For general guidance regarding the fabrication, storage, delivery, erection and bracing of trusses and truss systems, see **ANSI/TPI1 Quality Criteria, DSB-89 and BCSI Building Component Safety Information** available from Truss Plate Institute, 2670 Crain Highway, Suite 203 Waldorf, MD 20601



6904 Parke East Blvd.
 Tampa, FL 33610

Job 2525538	Truss T14	Truss Type Common	Qty 1	Ply 1	AMIRA BLDRS - THOMAS RES. T21805053
----------------	--------------	----------------------	----------	----------	--

Builders FirstSource (Jacksonville, FL),

Jacksonville, FL - 32244,

8.240 s Mar 9 2020 MiTek Industries, Inc. Thu Nov 5 09:19:17 2020 Page 1

ID:7WKr8toudn35dxwKwBAfQtytHta-G4dz0Ni63HLCjuWWBkwxMoArePDqmeX_zQIb0ByMH48

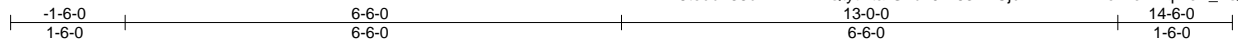

4x4 =

Scale = 1:30.2

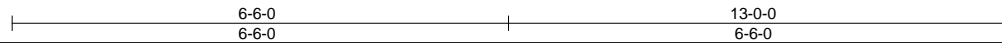
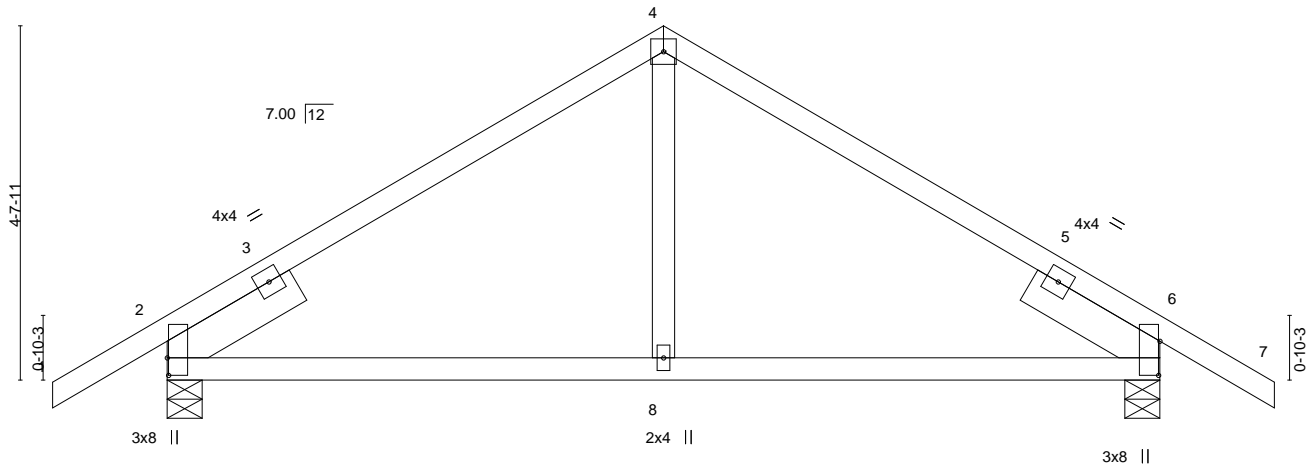

Plate Offsets (X,Y)--	[2:0-2-12,0-0-3], [6:0-5-6,0-0-3]									
LOADING (psf)	SPACING-	2-0-0	CSI.	DEFL.	in	(loc)	l/defl	L/d	PLATES	GRIP
TCLL 20.0	Plate Grip DOL 1.25		TC 0.37	Vert(LL) 0.05	8-11	>999	240		MT20	244/190
TCDL 7.0	Lumber DOL 1.25		BC 0.35	Vert(CT) -0.07	8-11	>999	180			
BCLL 0.0 *	Rep Stress Incr YES		WB 0.10	Horz(CT) 0.02	2	n/a	n/a			
BCDL 10.0	Code FBC2017/TPI2014		Matrix-MS						Weight: 62 lb	FT = 20%

LUMBER-

TOP CHORD 2x4 SP No.2
 BOT CHORD 2x4 SP No.2
 WEBS 2x4 SP No.3
 SLIDER Left 2x6 SP No.2 1-11-8, Right 2x6 SP No.2 1-11-8

BRACING-

TOP CHORD Structural wood sheathing directly applied or 6-0-0 oc purlins.
 BOT CHORD Rigid ceiling directly applied or 10-0-0 oc bracing.

REACTIONS.

(size) 2=0-5-8, 6=0-5-8
 Max Horz 2=-115(LC 10)
 Max Uplift 2=-157(LC 12), 6=-157(LC 13)
 Max Grav 2=562(LC 1), 6=562(LC 1)

FORCES. (lb) - Max. Comp./Max. Ten. - All forces 250 (lb) or less except when shown.

TOP CHORD 2-4=-456/187, 4-6=-456/187
 BOT CHORD 2-8=-61/394, 6-8=-61/394
 WEBS 4-8=-7/266

NOTES-

- Unbalanced roof live loads have been considered for this design.
- Wind: ASCE 7-10; Vult=130mph (3-second gust) Vasd=101mph; TCCL=4.2psf; BCCL=3.0psf; h=20ft; Cat. II; Exp B; Encl., GCpi=0.18; MWFRS (envelope) gable end zone and C-C Exterior(2) zone; C-C for members and forces & MWFRS for reactions shown; Lumber DOL=1.60 plate grip DOL=1.60
- This truss has been designed for a 10.0 psf bottom chord live load nonconcurrent with any other live loads.
- * This truss has been designed for a live load of 20.0psf on the bottom chord in all areas where a rectangle 3-6-0 tall by 2-0-0 wide will fit between the bottom chord and any other members.
- Provide mechanical connection (by others) of truss to bearing plate capable of withstanding 100 lb uplift at joint(s) except (jt=lb) 2=157, 6=157.

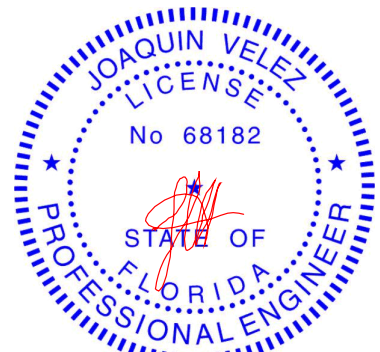

Joaquin Velez PE No.68182
 MiTek USA, Inc. FL Cert 6634
 6904 Parke East Blvd. Tampa FL 33610
 Date:

November 5, 2020

WARNING - Verify design parameters and READ NOTES ON THIS AND INCLUDED MITEK REFERENCE PAGE MII-7473 rev. 5/19/2020 BEFORE USE.

Design valid for use only with MiTek® connectors. This design is based only upon parameters shown, and is for an individual building component, not a truss system. Before use, the building designer must verify the applicability of design parameters and properly incorporate this design into the overall building design. Bracing indicated is to prevent buckling of individual truss web and/or chord members only. Additional temporary and permanent bracing is always required for stability and to prevent collapse with possible personal injury and property damage. For general guidance regarding the fabrication, storage, delivery, erection and bracing of trusses and truss systems, see **ANSI/TPI1 Quality Criteria, DSB-89 and BCSI Building Component Safety Information** available from Truss Plate Institute, 2670 Crain Highway, Suite 203 Waldorf, MD 20601



6904 Parke East Blvd.
 Tampa, FL 33610

Job 2525538	Truss T14G	Truss Type Common Supported Gable	Qty 1	Ply 1	AMIRA BLDRS - THOMAS RES. Job Reference (optional)	T21805054
----------------	---------------	--------------------------------------	----------	----------	---	-----------

Builders FirstSource (Jacksonville, FL), Jacksonville, FL - 32244,

8.240 s Mar 9 2020 MiTek Industries, Inc. Thu Nov 5 09:19:18 2020 Page 1

ID:7WKr8toudn35dxwKwBAfQtytHta-IGBLDjkkqbT3L25iIRRAvOj4CpeyV6u7C429YdyMH47

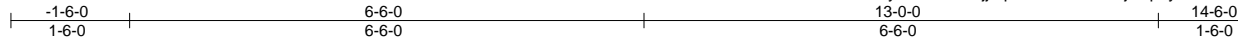

Scale = 1:29.1

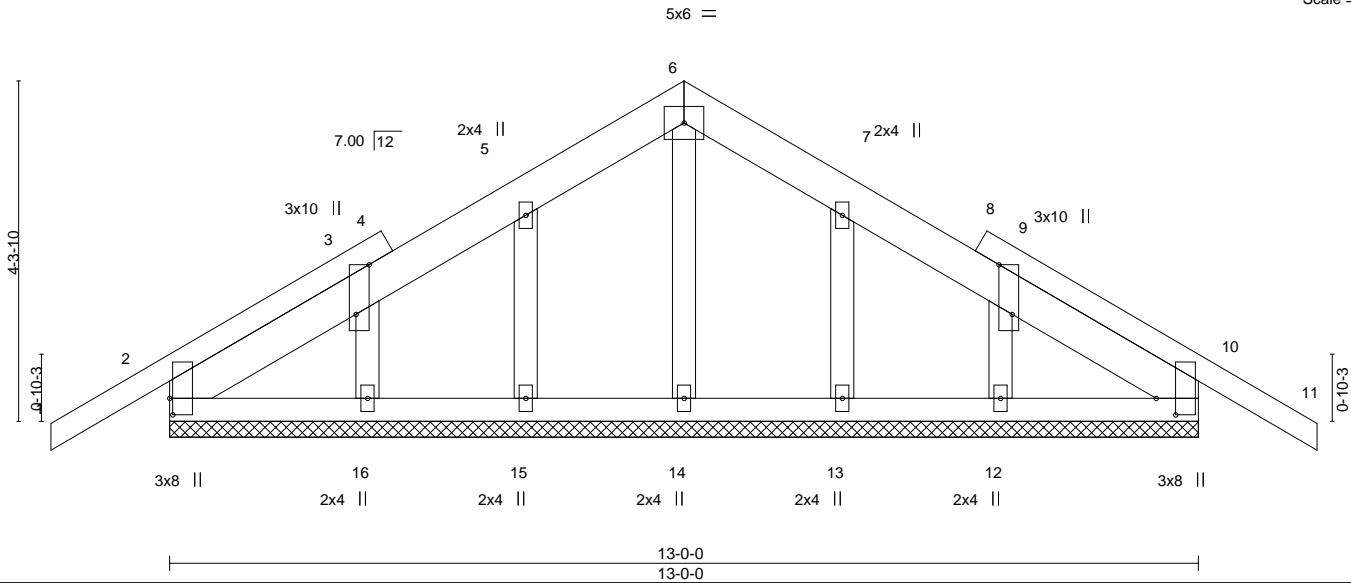

Plate Offsets (X,Y)--	[2:0-2-8,0-0-7], [3:0-7-8,Edge], [9:0-7-8,Edge], [10:0-2-8,0-2-15]				
LOADING (psf)	SPACING- 2-0-0	CSI.	DEFL. in (loc) l/defl L/d	PLATES	GRIP
TCLL 20.0	Plate Grip DOL 1.25	TC 0.12	Vert(LL) -0.00 11 n/r 120	MT20	244/190
TCDL 7.0	Lumber DOL 1.25	BC 0.04	Vert(CT) -0.01 11 n/r 120		
BCLL 0.0 *	Rep Stress Incr YES	WB 0.03	Horz(CT) 0.00 10 n/a n/a		
BCDL 10.0	Code FBC2017/TPI2014	Matrix-S		Weight: 86 lb	FT = 20%

LUMBER-
TOP CHORD 2x6 SP No.2 *Except*
1-4,8-11: 2x4 SP No.2
BOT CHORD 2x4 SP No.2
OTHERS 2x4 SP No.3

BRACING-
TOP CHORD Structural wood sheathing directly applied or 6-0-0 oc purlins.
BOT CHORD Rigid ceiling directly applied or 10-0-0 oc bracing.

REACTIONS. All bearings 13-0-0.
(lb) - Max Horz 2=105(LC 10)
Max Uplift All uplift 100 lb or less at joint(s) 2, 10, 15, 16, 13, 12
Max Grav All reactions 250 lb or less at joint(s) 2, 10, 14, 15, 16, 13, 12

FORCES. (lb) - Max. Comp./Max. Ten. - All forces 250 (lb) or less except when shown.

- NOTES-**
- Unbalanced roof live loads have been considered for this design.
 - Wind: ASCE 7-10; Vult=130mph (3-second gust) Vasd=101mph; TCDL=4.2psf; BCDL=3.0psf; h=20ft; Cat. II; Exp B; Encl., GCpi=0.18; MWFRS (envelope) gable end zone and C-C Exterior(2) zone;C-C for members and forces & MWFRS for reactions shown; Lumber DOL=1.60 plate grip DOL=1.60
 - Truss designed for wind loads in the plane of the truss only. For studs exposed to wind (normal to the face), see Standard Industry Gable End Details as applicable, or consult qualified building designer as per ANSI/TPI 1.
 - Gable requires continuous bottom chord bearing.
 - Gable studs spaced at 2-0-0 oc.
 - This truss has been designed for a 10.0 psf bottom chord live load nonconcurrent with any other live loads.
 - * This truss has been designed for a live load of 20.0psf on the bottom chord in all areas where a rectangle 3-6-0 tall by 2-0-0 wide will fit between the bottom chord and any other members.
 - Provide mechanical connection (by others) of truss to bearing plate capable of withstanding 100 lb uplift at joint(s) 2, 10, 15, 16, 13, 12.

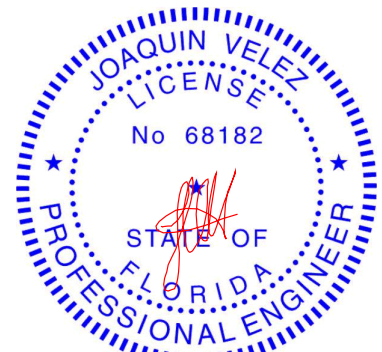

Joaquin Velez PE No.68182
MiTek USA, Inc. FL Cert 6634
6904 Parke East Blvd. Tampa FL 33610
Date:

November 5,2020

WARNING - Verify design parameters and READ NOTES ON THIS AND INCLUDED MITEK REFERENCE PAGE MII-7473 rev. 5/19/2020 BEFORE USE.
Design valid for use only with MiTek® connectors. This design is based only upon parameters shown, and is for an individual building component, not a truss system. Before use, the building designer must verify the applicability of design parameters and properly incorporate this design into the overall building design. Bracing indicated is to prevent buckling of individual truss web and/or chord members only. Additional temporary and permanent bracing is always required for stability and to prevent collapse with possible personal injury and property damage. For general guidance regarding the fabrication, storage, delivery, erection and bracing of trusses and truss systems, see **ANSI/TPI1 Quality Criteria, DSB-89 and BCSI Building Component Safety Information** available from Truss Plate Institute, 2670 Crain Highway, Suite 203 Waldorf, MD 20601



6904 Parke East Blvd.
Tampa, FL 33610

Job 2525538	Truss T15	Truss Type Common Girder	Qty 1	Ply 1	AMIRA BLDRS - THOMAS RES. Job Reference (optional)	T21805055
----------------	--------------	-----------------------------	----------	----------	---	-----------

Builders FirstSource (Jacksonville, FL),

Jacksonville, FL - 32244,

8.240 s Mar 9 2020 MiTek Industries, Inc. Thu Nov 5 09:19:19 2020 Page 1

ID:7WKr8toudn35dxwKwBAfQtytHta-DTlJR3kMbvbwzCgvJ9yPRDFDECyAERIHQkni43yMH46

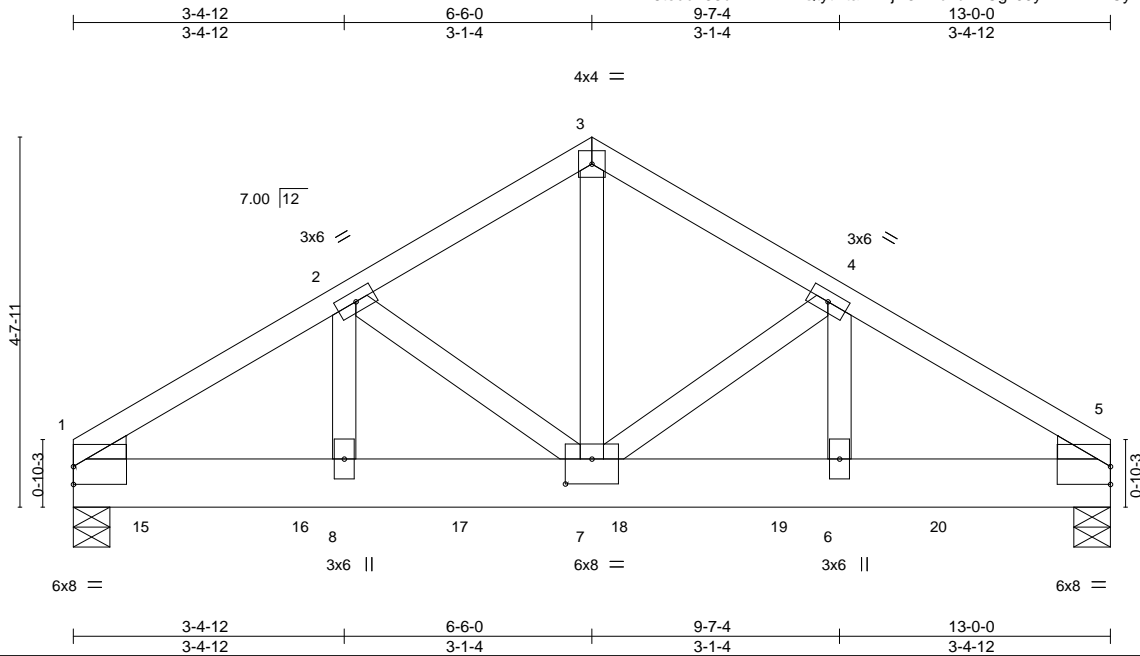

Scale = 1:28.9

Plate Offsets (X,Y)-- [1:0-0,0-2-11], [5:0-0,0-2-11], [7:0-4,0-3-12]

LOADING (psf)	SPACING-	2-0-0	CSI.	DEFL.	in (loc)	l/defl	L/d	PLATES	GRIP
TCLL 20.0	Plate Grip DOL	1.25	TC 0.23	Vert(LL)	-0.03	7	>999	MT20	244/190
TCDL 7.0	Lumber DOL	1.25	BC 0.17	Vert(CT)	-0.06	7	>999		
BCLL 0.0 *	Rep Stress Incr	NO	WB 0.53	Horz(CT)	0.01	5	n/a		
BCDL 10.0	Code FBC2017/TPI2014		Matrix-MS					Weight: 86 lb	FT = 20%

LUMBER-

TOP CHORD 2x4 SP No.2
 BOT CHORD 2x8 SP 2400F 2.0E
 WEBS 2x4 SP No.3
 WEDGE
 Left: 2x4 SP No.3, Right: 2x4 SP No.3

BRACING-

TOP CHORD Structural wood sheathing directly applied or 4-0-13 oc purlins.
 BOT CHORD Rigid ceiling directly applied or 10-0-0 oc bracing.

REACTIONS.

(size) 1=0-5-8, 5=0-5-8
 Max Horz 1=-94(LC 4)
 Max Uplift 1=-554(LC 8), 5=-489(LC 9)
 Max Grav 1=1671(LC 1), 5=1481(LC 1)

FORCES. (lb) - Max. Comp./Max. Ten. - All forces 250 (lb) or less except when shown.

TOP CHORD 1-2=-2010/663, 2-3=-1606/560, 3-4=-1606/560, 4-5=-1976/655
 BOT CHORD 1-8=-588/1689, 7-8=-588/1689, 6-7=-518/1659, 5-6=-518/1659
 WEBS 3-7=-483/1396, 4-7=-407/207, 4-6=-113/302, 2-7=-445/215, 2-8=-122/339

NOTES-

- Unbalanced roof live loads have been considered for this design.
- Wind: ASCE 7-10; Vult=130mph (3-second gust) Vasd=101mph; TCdL=4.2psf; BCdL=3.0psf; h=20ft; Cat. II; Exp B; Encl., GCpi=0.18; MWFRS (envelope) gable end zone; Lumber DOL=1.60 plate grip DOL=1.60
- This truss has been designed for a 10.0 psf bottom chord live load nonconcurrent with any other live loads.
- * This truss has been designed for a live load of 20.0psf on the bottom chord in all areas where a rectangle 3-6-0 tall by 2-0-0 wide will fit between the bottom chord and any other members.
- Provide mechanical connection (by others) of truss to bearing plate capable of withstanding 100 lb uplift at joint(s) except (jt=lb) 1=554, 5=489.
- Hanger(s) or other connection device(s) shall be provided sufficient to support concentrated load(s) 366 lb down and 146 lb up at 0-11-4, 365 lb down and 147 lb up at 2-11-4, 365 lb down and 147 lb up at 4-11-4, 365 lb down and 147 lb up at 6-11-4, and 365 lb down and 150 lb up at 8-11-4, and 365 lb down and 150 lb up at 10-11-4 on bottom chord. The design/selection of such connection device(s) is the responsibility of others.
- In the LOAD CASE(S) section, loads applied to the face of the truss are noted as front (F) or back (B).

LOAD CASE(S) Standard

- Dead + Roof Live (balanced): Lumber Increase=1.25, Plate Increase=1.25
 Uniform Loads (plf)
 Vert: 1-3=-54, 3-5=-54, 9-12=-20
 Concentrated Loads (lb)
 Vert: 15=-366(F) 16=-365(F) 17=-365(F) 18=-365(F) 19=-365(F) 20=-365(F)

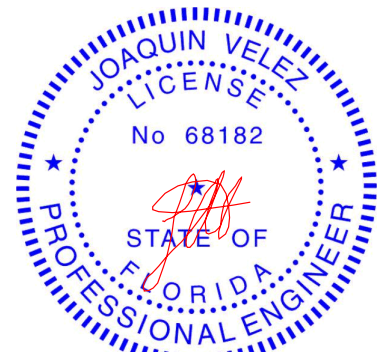

Joaquin Velez PE No.68182
 MiTek USA, Inc. FL Cert 6634
 6904 Parke East Blvd. Tampa FL 33610
 Date:

November 5, 2020

WARNING - Verify design parameters and READ NOTES ON THIS AND INCLUDED MITEK REFERENCE PAGE MII-7473 rev. 5/19/2020 BEFORE USE.

Design valid for use only with MiTek® connectors. This design is based only upon parameters shown, and is for an individual building component, not a truss system. Before use, the building designer must verify the applicability of design parameters and properly incorporate this design into the overall building design. Bracing indicated is to prevent buckling of individual truss web and/or chord members only. Additional temporary and permanent bracing is always required for stability and to prevent collapse with possible personal injury and property damage. For general guidance regarding the fabrication, storage, delivery, erection and bracing of trusses and truss systems, see ANSI/TPI1 Quality Criteria, DSB-89 and BCSI Building Component Safety Information available from Truss Plate Institute, 2670 Crain Highway, Suite 203 Waldorf, MD 20601



6904 Parke East Blvd.
 Tampa, FL 33610

Job 2525538	Truss T16	Truss Type GABLE	Qty 2	Ply 2	AMIRA BLDRS - THOMAS RES. T21805056
----------------	--------------	---------------------	----------	----------	--

Builders FirstSource (Jacksonville, FL), Jacksonville, FL - 32244,

8.240 s Mar 9 2020 MiTek Industries, Inc. Thu Nov 5 09:19:22 2020 Page 1

ID:7WKr8toudn35dxwKwBAfQtyHta-d1Rs35mEuq_VqgPT_HW63stjzQzmRs_j7i0MhOyMH43

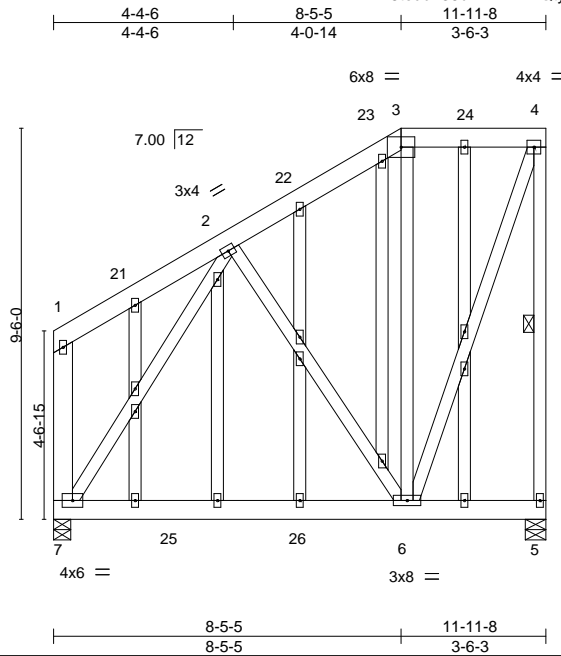

Scale = 1:56.0

LOADING (psf)	SPACING-	2-0-0	CSI.	DEFL.	in (loc)	l/defl	L/d	PLATES	GRIP
TCLL 20.0	Plate Grip DOL	1.25	TC 0.20	Vert(LL)	-0.02	6-7	>999	MT20	244/190
TCDL 7.0	Lumber DOL	1.25	BC 0.18	Vert(CT)	-0.05	6-7	>999		
BCLL 0.0 *	Rep Stress Incr	NO	WB 0.28	Horz(CT)	0.00	5	n/a		
BCDL 10.0	Code FBC2017/TPI2014		Matrix-MS					Weight: 308 lb	FT = 20%

LUMBER-

TOP CHORD 2x6 SP No.2
 BOT CHORD 2x6 SP No.2
 WEBS 2x4 SP No.3 *Except*
 1-7: 2x6 SP No.2
 OTHERS 2x4 SP No.3

BRACING-

TOP CHORD Structural wood sheathing directly applied or 6-0-0 oc purlins, except end verticals.
 BOT CHORD Rigid ceiling directly applied or 10-0-0 oc bracing.
 WEBS 1 Row at midpt 4-5

REACTIONS.

(size) 5=0-6-0, 7=0-5-0
 Max Horz 7=192(LC 28)
 Max Uplift 5=-436(LC 12), 7=-471(LC 12)
 Max Grav 5=1295(LC 37), 7=1947(LC 37)

FORCES. (lb) - Max. Comp./Max. Ten. - All forces 250 (lb) or less except when shown.

TOP CHORD 1-2=-312/192, 2-3=-732/232, 3-4=-428/185, 4-5=-1298/577, 1-7=-812/373
 BOT CHORD 6-7=-411/767
 WEBS 2-6=-627/426, 3-6=-541/246, 4-6=-545/1265, 2-7=-1180/406

NOTES-

- 2-ply truss to be connected together with 10d (0.131"x3") nails as follows:
 Top chords connected as follows: 2x6 - 2 rows staggered at 0-9-0 oc, 2x4 - 1 row at 0-9-0 oc.
 Bottom chords connected as follows: 2x6 - 2 rows staggered at 0-9-0 oc.
 Webs connected as follows: 2x4 - 1 row at 0-9-0 oc.
- All loads are considered equally applied to all plies, except if noted as front (F) or back (B) face in the LOAD CASE(S) section. Ply to ply connections have been provided to distribute only loads noted as (F) or (B), unless otherwise indicated.
- Wind: ASCE 7-10; Vult=130mph (3-second gust) Vasd=101mph; TCDL=4.2psf; BCDL=3.0psf; h=20ft; Cat. II; Exp B; Encl., GCpi=0.18; MWFRS (envelope) gable end zone and C-C Exterior(2) zone; end vertical left exposed; C-C for members and forces & MWFRS for reactions shown; Lumber DOL=1.60 plate grip DOL=1.60
- Truss designed for wind loads in the plane of the truss only. For studs exposed to wind (normal to the face), see Standard Industry Gable End Details as applicable, or consult qualified building designer as per ANSI/TPI 1.
- Provide adequate drainage to prevent water ponding.
- All plates are 2x4 MT20 unless otherwise indicated.
- Gable studs spaced at 2-0-0 oc.
- This truss has been designed for a 10.0 psf bottom chord live load nonconcurrent with any other live loads.
- * This truss has been designed for a live load of 20.0psf on the bottom chord in all areas where a rectangle 3-6-0 tall by 2-0-0 wide will fit between the bottom chord and any other members, with BCDL = 10.0psf.
- Provide mechanical connection (by others) of truss to bearing plate capable of withstanding 100 lb uplift at joint(s) except (jt=lb) 5=436, 7=471.
- Hanger(s) or other connection device(s) shall be provided sufficient to support concentrated load(s) 365 lb down and 139 lb up at 0-2-12, 365 lb down and 139 lb up at 2-0-4, 365 lb down and 139 lb up at 4-0-4, 365 lb down and 139 lb up at 6-0-4, and 365 lb down and 139 lb up at 8-0-4, and 267 lb down and 97 lb up at 10-0-4 on top chord. The design/selection of such connection device(s) is the responsibility of others.
- Studding applied to ply: 1(Front)

Continued on page 2

LOAD CASE(S) Standard

WARNING - Verify design parameters and READ NOTES ON THIS AND INCLUDED MITEK REFERENCE PAGE MII-7473 rev. 5/19/2020 BEFORE USE.

Design valid for use only with MiTek® connectors. This design is based only upon parameters shown, and is for an individual building component, not a truss system. Before use, the building designer must verify the applicability of design parameters and properly incorporate this design into the overall building design. Bracing indicated is to prevent buckling of individual truss web and/or chord members only. Additional temporary and permanent bracing is always required for stability and to prevent collapse with possible personal injury and property damage. For general guidance regarding the fabrication, storage, delivery, erection and bracing of trusses and truss systems, see **ANSI/TPI1 Quality Criteria, DSB-89 and BCSI Building Component Safety Information** available from Truss Plate Institute, 2670 Crain Highway, Suite 203 Waldorf, MD 20601

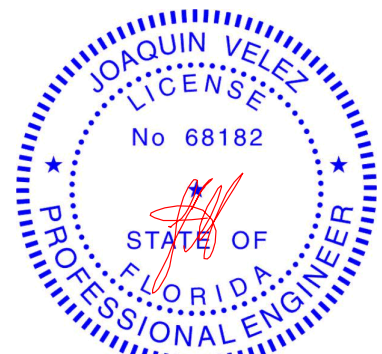

Joaquin Velez PE No.68182
 MiTek USA, Inc. FL Cert 6634
 6904 Parke East Blvd. Tampa FL 33610
 Date:

November 5, 2020



6904 Parke East Blvd.
 Tampa, FL 33610

Job 2525538	Truss T16	Truss Type GABLE	Qty 2	Ply 2	AMIRA BLDRS - THOMAS RES. T21805056 Job Reference (optional)
----------------	--------------	---------------------	----------	-----------------	--

Builders FirstSource (Jacksonville, FL), Jacksonville, FL - 32244,

8.240 s Mar 9 2020 MiTek Industries, Inc. Thu Nov 5 09:19:23 2020 Page 2
ID:7WKr8toudn35dxwKwBafQtytHta-5E?EGRnsf76LRp_gY?1Lc3QujqJ?AJEsLMlwDqyMH42

LOAD CASE(S) Standard

- 1) Dead + Roof Live (balanced): Lumber Increase=1.25, Plate Increase=1.25
Uniform Loads (plf)
Vert: 3-4=-54, 5-7=-20
Concentrated Loads (lb)
Vert: 1=-321 2=-321 21=-321 22=-321 23=-321 24=-267
Trapezoidal Loads (plf)
Vert: 1=-129(F=-75)-to-3=-54

 **WARNING - Verify design parameters and READ NOTES ON THIS AND INCLUDED MITEK REFERENCE PAGE MII-7473 rev. 5/19/2020 BEFORE USE.**

Design valid for use only with MiTek® connectors. This design is based only upon parameters shown, and is for an individual building component, not a truss system. Before use, the building designer must verify the applicability of design parameters and properly incorporate this design into the overall building design. Bracing indicated is to prevent buckling of individual truss web and/or chord members only. Additional temporary and permanent bracing is always required for stability and to prevent collapse with possible personal injury and property damage. For general guidance regarding the fabrication, storage, delivery, erection and bracing of trusses and truss systems, see **ANSI/TPI1 Quality Criteria, DSB-89 and BCSI Building Component Safety Information** available from Truss Plate Institute, 2670 Crain Highway, Suite 203 Waldorf, MD 20601



6904 Parke East Blvd.
Tampa, FL 36610

Job 2525538	Truss T17	Truss Type Common	Qty 5	Ply 1	AMIRA BLDRS - THOMAS RES. Job Reference (optional)	T21805057
----------------	--------------	----------------------	----------	----------	---	-----------

Builders FirstSource (Jacksonville, FL),

Jacksonville, FL - 32244,

8.240 s Mar 9 2020 MiTek Industries, Inc. Thu Nov 5 09:19:24 2020 Page 1

ID:7WKR8toudn35dxwKwBAfQtytHta-ZQYcUmoVQREC3zZs6iYa8Hy4FDfMvpo0a0VTiHyMH41

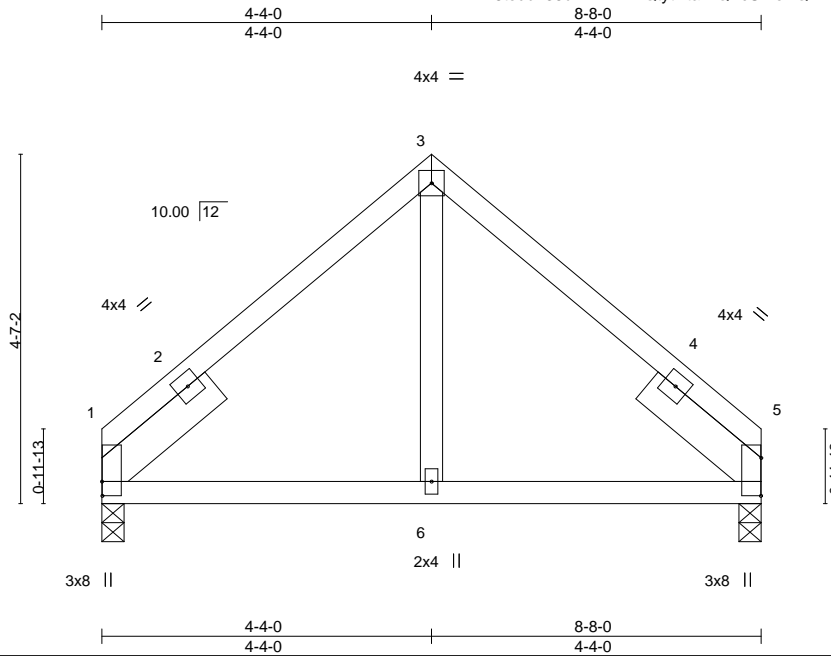

Scale = 1:30.3

LOADING (psf)		SPACING-		CSI.		DEFL.				PLATES	GRIP				
TCLL	20.0	Plate Grip DOL	2-0-0	TC	0.15	Vert(LL)	0.02	in (loc)	6-9	l/defl	>999	L/d	240	MT20	244/190
TCDL	7.0	Lumber DOL	1.25	BC	0.17	Vert(CT)	-0.02	6-9	>999	180					
BCLL	0.0 *	Rep Stress Incr	YES	WB	0.07	Horz(CT)	-0.01	1	n/a	n/a					
BCDL	10.0	Code	FBC2017/TPI2014	Matrix-MS										Weight: 45 lb	FT = 20%

LUMBER-
 TOP CHORD 2x4 SP No.2
 BOT CHORD 2x4 SP No.2
 WEBS 2x4 SP No.3
 SLIDER Left 2x6 SP No.2 1-11-8, Right 2x6 SP No.2 1-11-8

BRACING-
 TOP CHORD Structural wood sheathing directly applied or 6-0-0 oc purlins.
 BOT CHORD Rigid ceiling directly applied or 10-0-0 oc bracing.

REACTIONS. (size) 1=0-3-8, 5=0-3-8
 Max Horz 1=-89(LC 8)
 Max Uplift 1=-70(LC 12), 5=-70(LC 13)
 Max Grav 1=321(LC 1), 5=321(LC 1)

FORCES. (lb) - Max. Comp./Max. Ten. - All forces 250 (lb) or less except when shown.
 TOP CHORD 1-3=-272/136, 3-5=-272/136

- NOTES-**
- Unbalanced roof live loads have been considered for this design.
 - Wind: ASCE 7-10; Vult=130mph (3-second gust) Vasd=101mph; TCCL=4.2psf; BCCL=3.0psf; h=20ft; Cat. II; Exp B; Encl., GCpi=0.18; MWFRS (envelope) gable end zone and C-C Exterior(2) zone; C-C for members and forces & MWFRS for reactions shown; Lumber DOL=1.60 plate grip DOL=1.60
 - This truss has been designed for a 10.0 psf bottom chord live load nonconcurrent with any other live loads.
 - * This truss has been designed for a live load of 20.0psf on the bottom chord in all areas where a rectangle 3-6-0 tall by 2-0-0 wide will fit between the bottom chord and any other members.
 - Provide mechanical connection (by others) of truss to bearing plate capable of withstanding 100 lb uplift at joint(s) 1, 5.

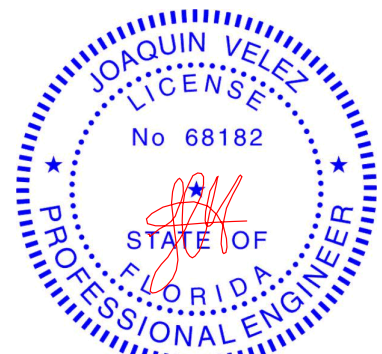

Joaquin Velez PE No.68182
 MiTek USA, Inc. FL Cert 6634
 6904 Parke East Blvd. Tampa FL 33610
 Date:

November 5, 2020

WARNING - Verify design parameters and READ NOTES ON THIS AND INCLUDED MITEK REFERENCE PAGE MII-7473 rev. 5/19/2020 BEFORE USE.

Design valid for use only with MiTek® connectors. This design is based only upon parameters shown, and is for an individual building component, not a truss system. Before use, the building designer must verify the applicability of design parameters and properly incorporate this design into the overall building design. Bracing indicated is to prevent buckling of individual truss web and/or chord members only. Additional temporary and permanent bracing is always required for stability and to prevent collapse with possible personal injury and property damage. For general guidance regarding the fabrication, storage, delivery, erection and bracing of trusses and truss systems, see **ANSI/TPI1 Quality Criteria, DSB-89 and BCSI Building Component Safety Information** available from Truss Plate Institute, 2670 Crain Highway, Suite 203 Waldorf, MD 20601



6904 Parke East Blvd.
 Tampa, FL 33610

Job 2525538	Truss T17G	Truss Type GABLE	Qty 1	Ply 1	AMIRA BLDRS - THOMAS RES. Job Reference (optional)	T21805058
----------------	---------------	---------------------	----------	----------	---	-----------

Builders FirstSource (Jacksonville, FL),

Jacksonville, FL - 32244,

8.240 s Mar 9 2020 MiTek Industries, Inc. Thu Nov 5 09:19:26 2020 Page 1

ID:7WKr8toudn35dxwKwBAfQtytHta-WpgMvSply2UwlHiFD7a2Di2QE1NgNkeJ2J_aq9yMH4?

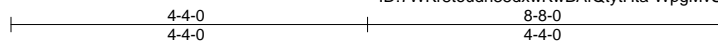

4x4 =

Scale = 1:28.0

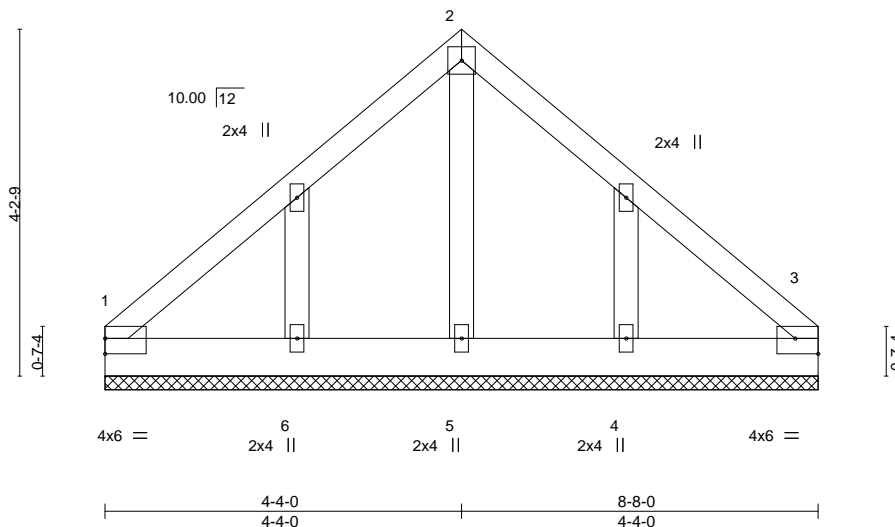

Plate Offsets (X,Y)-- [1:0-0-0,0-2-4], [3:Edge,0-2-4]

LOADING (psf)	SPACING-	2-0-0	CSI.	DEFL.	in (loc)	l/defl	L/d	PLATES	GRIP
TCLL 20.0	Plate Grip DOL	1.25	TC 0.18	Vert(LL)	n/a	-	n/a	MT20	244/190
TCDL 7.0	Lumber DOL	1.25	BC 0.05	Vert(CT)	n/a	-	n/a		
BCLL 0.0 *	Rep Stress Incr	YES	WB 0.04	Horz(CT)	0.00	3	n/a		
BCDL 10.0	Code	FBC2017/TPI2014	Matrix-S					Weight: 48 lb	FT = 20%

LUMBER-
 TOP CHORD 2x4 SP No.2
 BOT CHORD 2x6 SP No.2
 WEBS 2x4 SP No.3
 OTHERS 2x4 SP No.3

BRACING-
 TOP CHORD Structural wood sheathing directly applied or 6-0-0 oc purlins.
 BOT CHORD Rigid ceiling directly applied or 10-0-0 oc bracing.

REACTIONS. All bearings 8-8-0.
 (lb) - Max Horz 1=94(LC 8)
 Max Uplift All uplift 100 lb or less at joint(s) 1, 3, 5, 6, 4
 Max Grav All reactions 250 lb or less at joint(s) 1, 3, 5, 6, 4

FORCES. (lb) - Max. Comp./Max. Ten. - All forces 250 (lb) or less except when shown.

- NOTES-**
- Unbalanced roof live loads have been considered for this design.
 - Wind: ASCE 7-10; Vult=130mph (3-second gust) Vasd=101mph; TC DL=4.2psf; BC DL=3.0psf; h=20ft; Cat. II; Exp B; Encl., GCpi=0.18; MWFRS (envelope) gable end zone and C-C Exterior(2) zone; C-C for members and forces & MWFRS for reactions shown; Lumber DOL=1.60 plate grip DOL=1.60
 - Truss designed for wind loads in the plane of the truss only. For studs exposed to wind (normal to the face), see Standard Industry Gable End Details as applicable, or consult qualified building designer as per ANSI/TPI 1.
 - Gable requires continuous bottom chord bearing.
 - Gable studs spaced at 2-0-0 oc.
 - This truss has been designed for a 10.0 psf bottom chord live load nonconcurrent with any other live loads.
 - * This truss has been designed for a live load of 20.0psf on the bottom chord in all areas where a rectangle 3-6-0 tall by 2-0-0 wide will fit between the bottom chord and any other members.
 - Provide mechanical connection (by others) of truss to bearing plate capable of withstanding 100 lb uplift at joint(s) 1, 3, 5, 6, 4.

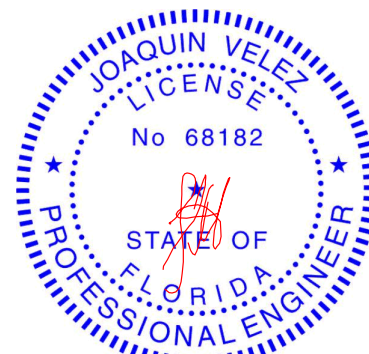

Joaquin Velez PE No.68182
 MiTek USA, Inc. FL Cert 6634
 6904 Parke East Blvd. Tampa FL 33610
 Date:

November 5, 2020

WARNING - Verify design parameters and READ NOTES ON THIS AND INCLUDED MITEK REFERENCE PAGE MII-7473 rev. 5/19/2020 BEFORE USE.
 Design valid for use only with MiTek® connectors. This design is based only upon parameters shown, and is for an individual building component, not a truss system. Before use, the building designer must verify the applicability of design parameters and properly incorporate this design into the overall building design. Bracing indicated is to prevent buckling of individual truss web and/or chord members only. Additional temporary and permanent bracing is always required for stability and to prevent collapse with possible personal injury and property damage. For general guidance regarding the fabrication, storage, delivery, erection and bracing of trusses and truss systems, see **ANSI/TPI1 Quality Criteria, DSB-89 and BCSI Building Component Safety Information** available from Truss Plate Institute, 2670 Crain Highway, Suite 203 Waldorf, MD 20601



Job 2525538	Truss V01	Truss Type GABLE	Qty 2	Ply 1	AMIRA BLDRS - THOMAS RES. T21805059
----------------	--------------	---------------------	----------	----------	--

Builders FirstSource (Jacksonville, FL),

Jacksonville, FL - 32244,

8.240 s Mar 9 2020 MiTek Industries, Inc. Thu Nov 5 09:19:28 2020 Page 1

ID:7WKR8toudn35dxwKwBAfQtytHta-SBo7K8r?UgkeYbsdLYdWJ77ocr3UreDbVdTh2yMH3z

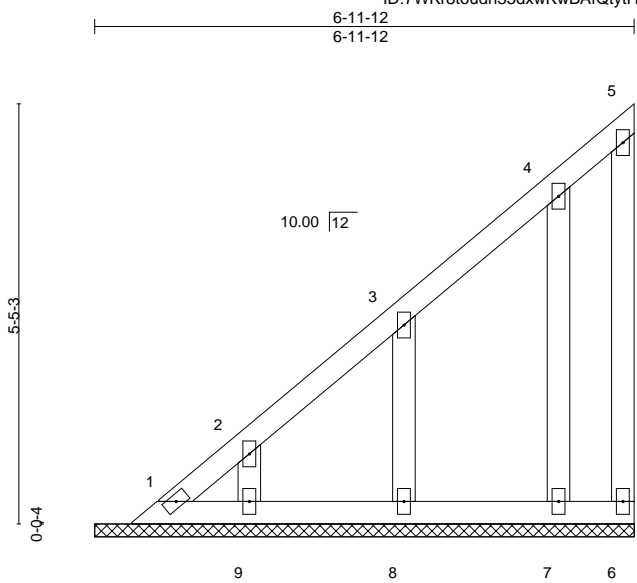

Scale = 1:29.8

LOADING (psf)	SPACING-	2-0-0	CSI.	DEFL.	in (loc)	l/defl	L/d	PLATES	GRIP	
TCLL 20.0	Plate Grip DOL	1.25	TC 0.06	Vert(LL)	n/a	-	n/a	999	MT20	244/190
TCDL 7.0	Lumber DOL	1.25	BC 0.03	Vert(CT)	n/a	-	n/a	999		
BCLL 0.0 *	Rep Stress Incr	YES	WB 0.04	Horz(CT)	0.00		n/a	n/a		
BCDL 10.0	Code FBC2017/TPI2014		Matrix-P						Weight: 39 lb	FT = 20%

LUMBER-

TOP CHORD 2x4 SP No.2
 BOT CHORD 2x4 SP No.2
 WEBS 2x4 SP No.3
 OTHERS 2x4 SP No.3

BRACING-

TOP CHORD Structural wood sheathing directly applied or 6-0-0 oc purlins, except end verticals.
 BOT CHORD Rigid ceiling directly applied or 10-0-0 oc bracing.

REACTIONS. All bearings 6-11-12.

(lb) - Max Horz 1=192(LC 12)
 Max Uplift All uplift 100 lb or less at joint(s) 1, 6, 9, 7 except 8=110(LC 12)
 Max Grav All reactions 250 lb or less at joint(s) 1, 6, 9, 8, 7

FORCES. (lb) - Max. Comp./Max. Ten. - All forces 250 (lb) or less except when shown.

TOP CHORD 1-2=-256/208

NOTES-

- 1) Wind: ASCE 7-10; Vult=130mph (3-second gust) Vasd=101mph; TCCL=4.2psf; BCDL=3.0psf; h=20ft; Cat. II; Exp B; Encl., GCpi=0.18; MWFRS (envelope) gable end zone and C-C Exterior(2) zone; C-C for members and forces & MWFRS for reactions shown; Lumber DOL=1.60 plate grip DOL=1.60
- 2) All plates are 2x4 MT20 unless otherwise indicated.
- 3) Gable requires continuous bottom chord bearing.
- 4) This truss has been designed for a 10.0 psf bottom chord live load nonconcurrent with any other live loads.
- 5) * This truss has been designed for a live load of 20.0psf on the bottom chord in all areas where a rectangle 3-6-0 tall by 2-0-0 wide will fit between the bottom chord and any other members.
- 6) Provide mechanical connection (by others) of truss to bearing plate capable of withstanding 100 lb uplift at joint(s) 1, 6, 9, 7 except (jt=lb) 8=110.

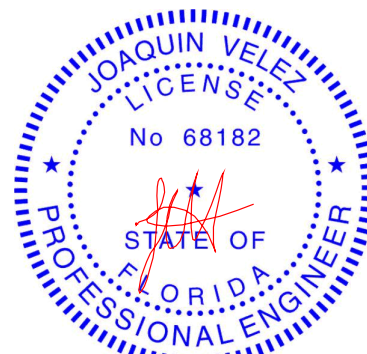

Joaquin Velez PE No.68182
 MiTek USA, Inc. FL Cert 6634
 6904 Parke East Blvd. Tampa FL 33610
 Date:

November 5, 2020

WARNING - Verify design parameters and READ NOTES ON THIS AND INCLUDED MITEK REFERENCE PAGE MII-7473 rev. 5/19/2020 BEFORE USE.

Design valid for use only with MiTek® connectors. This design is based only upon parameters shown, and is for an individual building component, not a truss system. Before use, the building designer must verify the applicability of design parameters and properly incorporate this design into the overall building design. Bracing indicated is to prevent buckling of individual truss web and/or chord members only. Additional temporary and permanent bracing is always required for stability and to prevent collapse with possible personal injury and property damage. For general guidance regarding the fabrication, storage, delivery, erection and bracing of trusses and truss systems, see **ANSI/TPI1 Quality Criteria, DSB-89 and BCSI Building Component Safety Information** available from Truss Plate Institute, 2670 Crain Highway, Suite 203 Waldorf, MD 20601



6904 Parke East Blvd.
 Tampa, FL 33610

Job 2525538	Truss V02	Truss Type Valley	Qty 2	Ply 1	AMIRA BLDRS - THOMAS RES. T21805060
----------------	--------------	----------------------	----------	----------	--

Builders FirstSource (Jacksonville, FL),

Jacksonville, FL - 32244,

8.240 s Mar 9 2020 MiTek Industries, Inc. Thu Nov 5 09:19:31 2020 Page 1

ID:7WKr8toudn35dxwKwBAfQtytHta-smUFyAtumb6DP2bC0gADwllDr20i2?Z2BbhLUNyMH3w

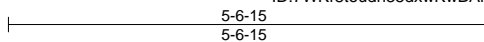

Scale = 1:26.8

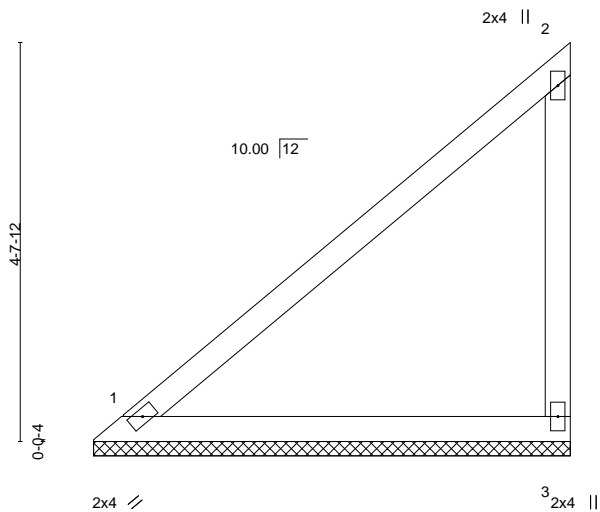

LOADING (psf)	SPACING-	CSI.	DEFL.	in (loc)	l/defl	L/d	PLATES	GRIP
TCLL 20.0	2-0-0	TC 0.45	Vert(LL)	n/a	-	n/a	MT20	244/190
TCDL 7.0	Plate Grip DOL 1.25	BC 0.32	Vert(CT)	n/a	-	n/a		
BCLL 0.0 *	Lumber DOL 1.25	WB 0.00	Horz(CT)	0.00		n/a		
BCDL 10.0	Rep Stress Incr YES	Matrix-P						
	Code FBC2017/TPI2014						Weight: 24 lb	FT = 20%

LUMBER-
 TOP CHORD 2x4 SP No.2
 BOT CHORD 2x4 SP No.2
 WEBS 2x4 SP No.3

BRACING-
 TOP CHORD Structural wood sheathing directly applied or 5-6-15 oc purlins, except end verticals.
 BOT CHORD Rigid ceiling directly applied or 10-0-0 oc bracing.

REACTIONS. (size) 1=5-6-10, 3=5-6-10
 Max Horz 1=162(LC 12)
 Max Uplift 3=128(LC 12)
 Max Grav 1=186(LC 1), 3=205(LC 19)

FORCES. (lb) - Max. Comp./Max. Ten. - All forces 250 (lb) or less except when shown.

- NOTES-**
- 1) Wind: ASCE 7-10; Vult=130mph (3-second gust) Vasd=101mph; TCDL=4.2psf; BCDL=3.0psf; h=20ft; Cat. II; Exp B; Encl., GCpi=0.18; MWFRS (envelope) gable end zone and C-C Exterior(2) zone; C-C for members and forces & MWFRS for reactions shown; Lumber DOL=1.60 plate grip DOL=1.60
 - 2) Gable requires continuous bottom chord bearing.
 - 3) This truss has been designed for a 10.0 psf bottom chord live load nonconcurrent with any other live loads.
 - 4) * This truss has been designed for a live load of 20.0psf on the bottom chord in all areas where a rectangle 3-6-0 tall by 2-0-0 wide will fit between the bottom chord and any other members.
 - 5) Provide mechanical connection (by others) of truss to bearing plate capable of withstanding 100 lb uplift at joint(s) except (jt=lb) 3=128.

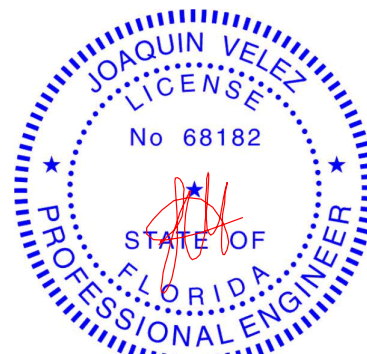

Joaquin Velez PE No.68182
 MiTek USA, Inc. FL Cert 6634
 6904 Parke East Blvd. Tampa FL 33610
 Date:

November 5, 2020

WARNING - Verify design parameters and READ NOTES ON THIS AND INCLUDED MITEK REFERENCE PAGE MII-7473 rev. 5/19/2020 BEFORE USE.
 Design valid for use only with MiTek® connectors. This design is based only upon parameters shown, and is for an individual building component, not a truss system. Before use, the building designer must verify the applicability of design parameters and properly incorporate this design into the overall building design. Bracing indicated is to prevent buckling of individual truss web and/or chord members only. Additional temporary and permanent bracing is always required for stability and to prevent collapse with possible personal injury and property damage. For general guidance regarding the fabrication, storage, delivery, erection and bracing of trusses and truss systems, see **ANSI/TPI1 Quality Criteria, DSB-89 and BCSI Building Component Safety Information** available from Truss Plate Institute, 2670 Crain Highway, Suite 203 Waldorf, MD 20601



Job 2525538	Truss V03	Truss Type Valley	Qty 2	Ply 1	AMIRA BLDRS - THOMAS RES. T21805061
----------------	--------------	----------------------	----------	----------	--

Builders FirstSource (Jacksonville, FL),

Jacksonville, FL - 32244,

8.240 s Mar 9 2020 MiTek Industries, Inc. Thu Nov 5 09:19:32 2020 Page 1

ID:7WKr8toudn35dxwKwBAfQtytHta-Kz1e9VuWXuE40CAOaOhSTzIR4SORnSpBQFRu1pyMH3v
4-2-2
4-2-2

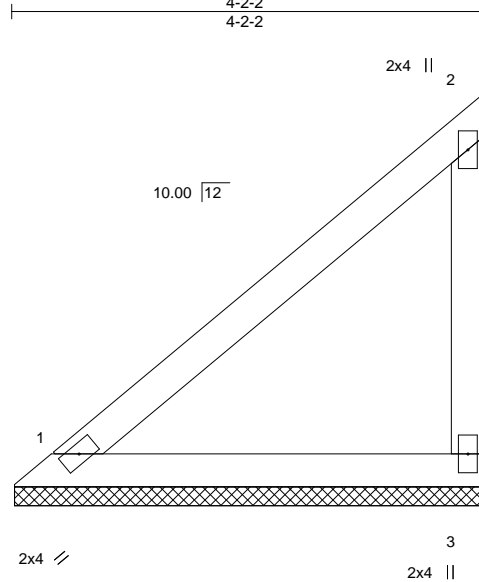

Scale = 1:20.4

LOADING (psf)	SPACING-	CSI.	DEFL.	in (loc)	l/defl	L/d	PLATES	GRIP
TCLL 20.0	2-0-0	TC 0.22	Vert(LL)	n/a	-	n/a	MT20	244/190
TCDL 7.0	Plate Grip DOL 1.25	BC 0.16	Vert(CT)	n/a	-	n/a		
BCLL 0.0 *	Lumber DOL 1.25	WB 0.00	Horz(CT)	0.00		n/a		
BCDL 10.0	Rep Stress Incr YES	Matrix-P						
	Code FBC2017/TPI2014						Weight: 18 lb	FT = 20%

LUMBER-

TOP CHORD 2x4 SP No.2
BOT CHORD 2x4 SP No.2
WEBS 2x4 SP No.3

BRACING-

TOP CHORD Structural wood sheathing directly applied or 4-2-2 oc purlins, except end verticals.
BOT CHORD Rigid ceiling directly applied or 10-0-0 oc bracing.

REACTIONS.

(size) 1=4-1-13, 3=4-1-13
Max Horz 1=117(LC 12)
Max Uplift 3=93(LC 12)
Max Grav 1=134(LC 1), 3=148(LC 19)

FORCES. (lb) - Max. Comp./Max. Ten. - All forces 250 (lb) or less except when shown.

NOTES-

- 1) Wind: ASCE 7-10; Vult=130mph (3-second gust) Vasd=101mph; TCDL=4.2psf; BCDL=3.0psf; h=20ft; Cat. II; Exp B; Encl., GCpi=0.18; MWFRS (envelope) gable end zone and C-C Exterior(2) zone;C-C for members and forces & MWFRS for reactions shown; Lumber DOL=1.60 plate grip DOL=1.60
- 2) Gable requires continuous bottom chord bearing.
- 3) This truss has been designed for a 10.0 psf bottom chord live load nonconcurrent with any other live loads.
- 4) * This truss has been designed for a live load of 20.0psf on the bottom chord in all areas where a rectangle 3-6-0 tall by 2-0-0 wide will fit between the bottom chord and any other members.
- 5) Provide mechanical connection (by others) of truss to bearing plate capable of withstanding 100 lb uplift at joint(s) 3.

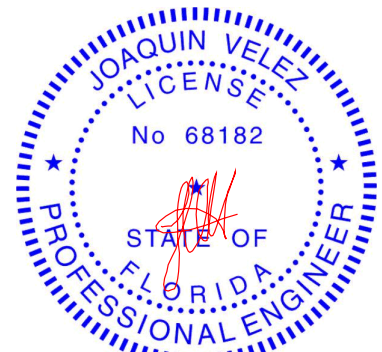

Joaquin Velez PE No.68182
MiTek USA, Inc. FL Cert 6634
6904 Parke East Blvd. Tampa FL 33610
Date:

November 5, 2020

WARNING - Verify design parameters and READ NOTES ON THIS AND INCLUDED MITEK REFERENCE PAGE MII-7473 rev. 5/19/2020 BEFORE USE.

Design valid for use only with MiTek® connectors. This design is based only upon parameters shown, and is for an individual building component, not a truss system. Before use, the building designer must verify the applicability of design parameters and properly incorporate this design into the overall building design. Bracing indicated is to prevent buckling of individual truss web and/or chord members only. Additional temporary and permanent bracing is always required for stability and to prevent collapse with possible personal injury and property damage. For general guidance regarding the fabrication, storage, delivery, erection and bracing of trusses and truss systems, see **ANSI/TPI1 Quality Criteria, DSB-89 and BCSI Building Component Safety Information** available from Truss Plate Institute, 2670 Crain Highway, Suite 203 Waldorf, MD 20601



6904 Parke East Blvd.
Tampa, FL 33610

Job 2525538	Truss V04	Truss Type Valley	Qty 2	Ply 1	AMIRA BLDRS - THOMAS RES. T21805062
----------------	--------------	----------------------	----------	----------	--

Builders FirstSource (Jacksonville, FL),

Jacksonville, FL - 32244,

8.240 s Mar 9 2020 MiTek Industries, Inc. Thu Nov 5 09:19:33 2020 Page 1

ID:7WKr8toudn35dxwKwBAfQtytHta-o9b0Nrv8lCMxeMlb75Ch0Aqe3smFWv3KfvASZFyMH3u

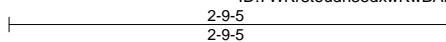

Scale = 1:14.5

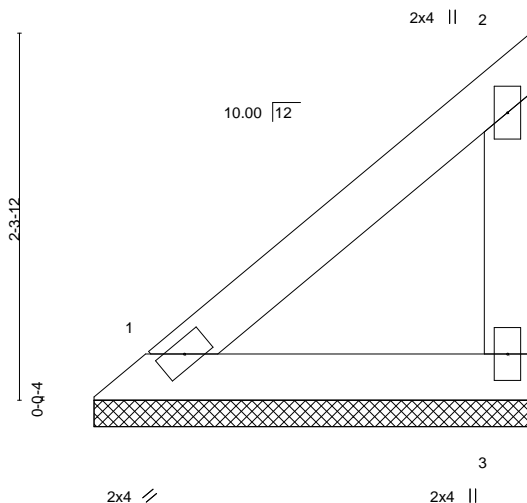

LOADING (psf)	SPACING-	CSI.	DEFL.	in (loc)	l/defl	L/d	PLATES	GRIP
TCLL 20.0	2-0-0	TC 0.08	Vert(LL)	n/a	-	n/a	MT20	244/190
TCDL 7.0	Plate Grip DOL 1.25	BC 0.05	Vert(CT)	n/a	-	n/a		
BCLL 0.0 *	Lumber DOL 1.25	WB 0.00	Horz(CT)	0.00		n/a		
BCDL 10.0	Rep Stress Incr YES	Matrix-P						
	Code FBC2017/TPI2014						Weight: 11 lb	FT = 20%

LUMBER-

TOP CHORD 2x4 SP No.2
 BOT CHORD 2x4 SP No.2
 WEBS 2x4 SP No.3

BRACING-

TOP CHORD Structural wood sheathing directly applied or 2-9-5 oc purlins, except end verticals.
 BOT CHORD Rigid ceiling directly applied or 10-0-0 oc bracing.

REACTIONS. (size) 1=2-9-1, 3=2-9-1
 Max Horz 1=72(LC 12)
 Max Uplift 3=57(LC 12)
 Max Grav 1=82(LC 1), 3=91(LC 19)

FORCES. (lb) - Max. Comp./Max. Ten. - All forces 250 (lb) or less except when shown.

NOTES-

- 1) Wind: ASCE 7-10; Vult=130mph (3-second gust) Vasd=101mph; TCDL=4.2psf; BCDL=3.0psf; h=20ft; Cat. II; Exp B; Encl., GCpi=0.18; MWFRS (envelope) gable end zone and C-C Exterior(2) zone; C-C for members and forces & MWFRS for reactions shown; Lumber DOL=1.60 plate grip DOL=1.60
- 2) Gable requires continuous bottom chord bearing.
- 3) This truss has been designed for a 10.0 psf bottom chord live load nonconcurrent with any other live loads.
- 4) * This truss has been designed for a live load of 20.0psf on the bottom chord in all areas where a rectangle 3-6-0 tall by 2-0-0 wide will fit between the bottom chord and any other members.
- 5) Provide mechanical connection (by others) of truss to bearing plate capable of withstanding 100 lb uplift at joint(s) 3.

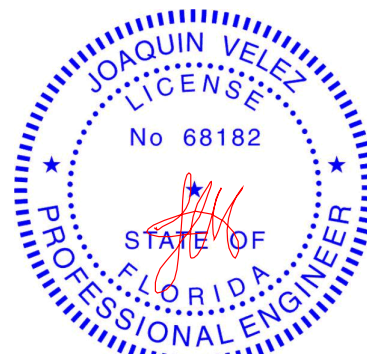

Joaquin Velez PE No.68182
 MiTek USA, Inc. FL Cert 6634
 6904 Parke East Blvd. Tampa FL 33610
 Date:

November 5, 2020

WARNING - Verify design parameters and READ NOTES ON THIS AND INCLUDED MITEK REFERENCE PAGE MII-7473 rev. 5/19/2020 BEFORE USE.

Design valid for use only with MiTek® connectors. This design is based only upon parameters shown, and is for an individual building component, not a truss system. Before use, the building designer must verify the applicability of design parameters and properly incorporate this design into the overall building design. Bracing indicated is to prevent buckling of individual truss web and/or chord members only. Additional temporary and permanent bracing is always required for stability and to prevent collapse with possible personal injury and property damage. For general guidance regarding the fabrication, storage, delivery, erection and bracing of trusses and truss systems, see **ANSI/TPI1 Quality Criteria, DSB-89 and BCSI Building Component Safety Information** available from Truss Plate Institute, 2670 Crain Highway, Suite 203 Waldorf, MD 20601



6904 Parke East Blvd.
 Tampa, FL 33610

Job 2525538	Truss V05	Truss Type Valley	Qty 1	Ply 1	AMIRA BLDRS - THOMAS RES. Job Reference (optional)	T21805063
----------------	--------------	----------------------	----------	----------	---	-----------

Builders FirstSource (Jacksonville, FL),

Jacksonville, FL - 32244,

8.240 s Mar 9 2020 MiTek Industries, Inc. Thu Nov 5 09:19:34 2020 Page 1

ID:7WKr8toudn35dxwKwBAfQtytHta-HL9OaBvm3WUoGwKnhpkwYONobF4bFKLUzW?5iyMH3t

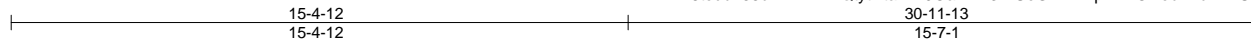

4x4 =

Scale = 1:57.5

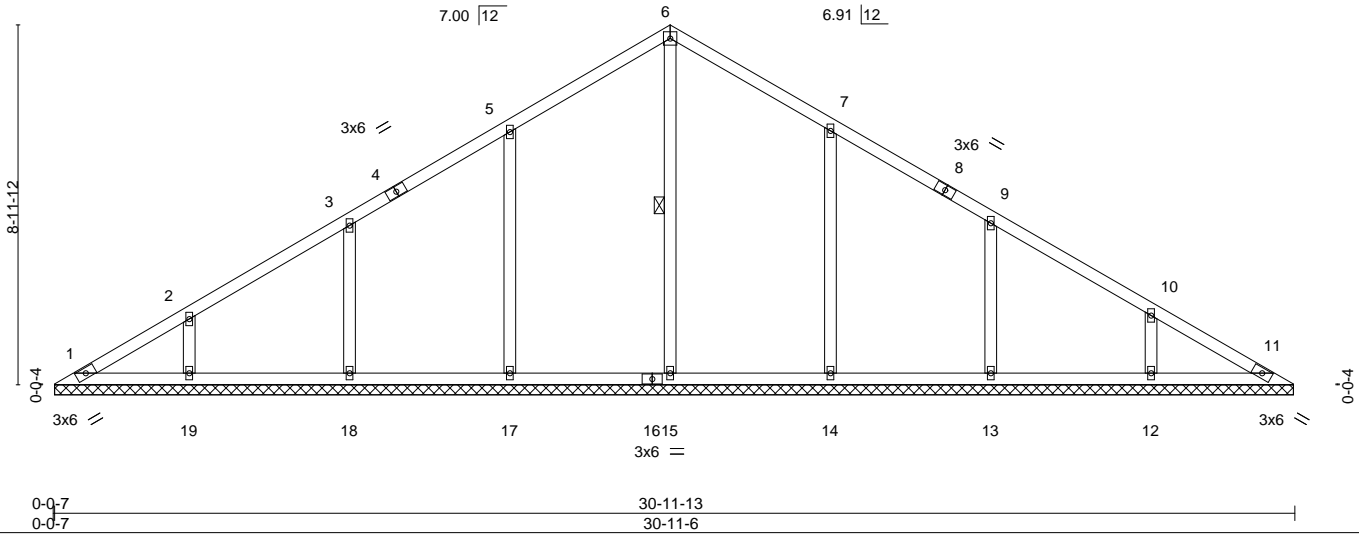

LOADING (psf)	SPACING-	2-0-0	CSI.	DEFL.	in (loc)	l/defl	L/d	PLATES	GRIP	
TCLL 20.0	Plate Grip DOL	1.25	TC 0.16	Vert(LL)	n/a	-	n/a	999	MT20	244/190
TCDL 7.0	Lumber DOL	1.25	BC 0.18	Vert(CT)	n/a	-	n/a	999		
BCLL 0.0 *	Rep Stress Incr	YES	WB 0.19	Horz(CT)	0.01	11	n/a	n/a		
BCDL 10.0	Code	FBC2017/TPI2014	Matrix-S						Weight: 144 lb	FT = 20%

LUMBER-
 TOP CHORD 2x4 SP No.2
 BOT CHORD 2x4 SP No.2
 OTHERS 2x4 SP No.3

BRACING-
 TOP CHORD Structural wood sheathing directly applied or 6-0-0 oc purlins.
 BOT CHORD Rigid ceiling directly applied or 10-0-0 oc bracing.
 WEBS 1 Row at midpt 6-15

REACTIONS. All bearings 30-10-15.
 (lb) - Max Horz 1=-215(LC 8)
 Max Uplift All uplift 100 lb or less at joint(s) 1, 11 except 17=-162(LC 12), 18=-149(LC 12), 19=-143(LC 12), 14=-160(LC 13), 13=-147(LC 13), 12=-146(LC 13)
 Max Grav All reactions 250 lb or less at joint(s) 1, 11 except 15=379(LC 22), 17=457(LC 19), 18=372(LC 19), 19=289(LC 19), 14=456(LC 20), 13=369(LC 20), 12=296(LC 20)

FORCES. (lb) - Max. Comp./Max. Ten. - All forces 250 (lb) or less except when shown.

NOTES-

- Unbalanced roof live loads have been considered for this design.
- Wind: ASCE 7-10; Vult=130mph (3-second gust) Vasd=101mph; TCDL=4.2psf; BCDL=3.0psf; h=20ft; Cat. II; Exp B; Encl., GCpi=0.18; MWFRS (envelope) gable end zone and C-C Exterior(2) zone; C-C for members and forces & MWFRS for reactions shown; Lumber DOL=1.60 plate grip DOL=1.60
- All plates are 2x4 MT20 unless otherwise indicated.
- Gable requires continuous bottom chord bearing.
- This truss has been designed for a 10.0 psf bottom chord live load nonconcurrent with any other live loads.
- * This truss has been designed for a live load of 20.0psf on the bottom chord in all areas where a rectangle 3-6-0 tall by 2-0-0 wide will fit between the bottom chord and any other members, with BCDL = 10.0psf.
- Provide mechanical connection (by others) of truss to bearing plate capable of withstanding 100 lb uplift at joint(s) 1, 11 except (jt=lb) 17=162, 18=149, 19=143, 14=160, 13=147, 12=146.

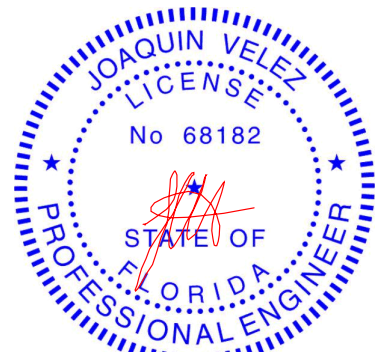

Joaquin Velez PE No.68182
 MiTek USA, Inc. FL Cert 6634
 6904 Parke East Blvd. Tampa FL 33610
 Date:

November 5, 2020

WARNING - Verify design parameters and READ NOTES ON THIS AND INCLUDED MITEK REFERENCE PAGE MII-7473 rev. 5/19/2020 BEFORE USE.

Design valid for use only with MiTek® connectors. This design is based only upon parameters shown, and is for an individual building component, not a truss system. Before use, the building designer must verify the applicability of design parameters and properly incorporate this design into the overall building design. Bracing indicated is to prevent buckling of individual truss web and/or chord members only. Additional temporary and permanent bracing is always required for stability and to prevent collapse with possible personal injury and property damage. For general guidance regarding the fabrication, storage, delivery, erection and bracing of trusses and truss systems, see **ANSI/TPI1 Quality Criteria, DSB-89 and BCSI Building Component Safety Information** available from Truss Plate Institute, 2670 Crain Highway, Suite 203 Waldorf, MD 20601



6904 Parke East Blvd.
 Tampa, FL 33610

Job 2525538	Truss V06	Truss Type Valley	Qty 1	Ply 1	AMIRA BLDRS - THOMAS RES. Job Reference (optional)	T21805064
----------------	--------------	----------------------	----------	----------	---	-----------

Builders FirstSource (Jacksonville, FL),

Jacksonville, FL - 32244,

8.240 s Mar 9 2020 MiTek Industries, Inc. Thu Nov 5 09:19:35 2020 Page 1
ID:7WKr8toudn35dxwKwBAfQtyrHta-IYjmoXwOqpcetfuzFWF95bwz9fPa_m4d6DYd8yMH3s

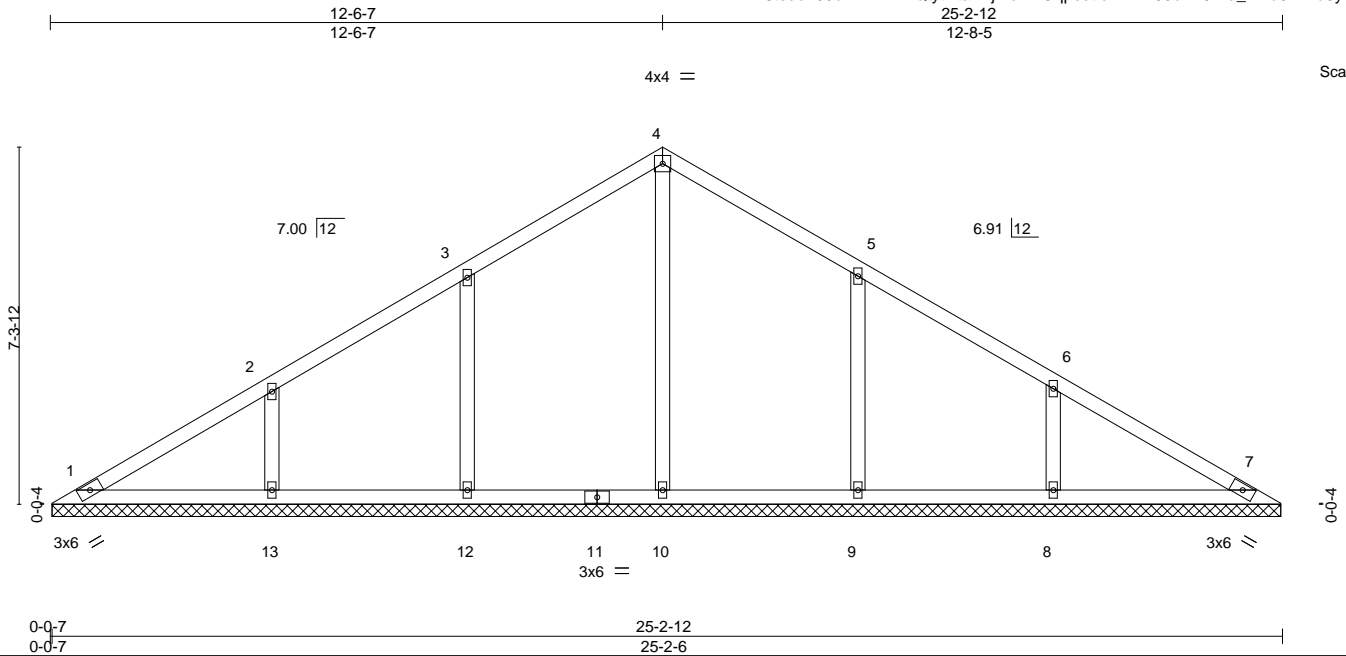

Scale = 1:47.2

LOADING (psf)	SPACING-	CSL.	DEFL.	in (loc)	l/defl	L/d	PLATES	GRIP
TCLL 20.0	2-0-0	TC 0.17	Vert(LL)	n/a	-	n/a	MT20	244/190
TCDL 7.0	Plate Grip DOL 1.25	BC 0.19	Vert(CT)	n/a	-	n/a		
BCLL 0.0 *	Lumber DOL 1.25	WB 0.16	Horz(CT)	0.00	7	n/a		
BCDL 10.0	Rep Stress Incr YES	Matrix-S						
	Code FBC2017/TPI2014						Weight: 108 lb	FT = 20%

LUMBER-

TOP CHORD 2x4 SP No.2
BOT CHORD 2x4 SP No.2
OTHERS 2x4 SP No.3

BRACING-

TOP CHORD Structural wood sheathing directly applied or 6-0-0 oc purlins.
BOT CHORD Rigid ceiling directly applied or 10-0-0 oc bracing.

REACTIONS.

All bearings 25-1-15.
(lb) - Max Horz 1=173(LC 8)
Max Uplift All uplift 100 lb or less at joint(s) 1, 7 except 12=157(LC 12), 13=166(LC 12), 9=154(LC 13), 8=169(LC 13)
Max Grav All reactions 250 lb or less at joint(s) 1, 7 except 10=382(LC 22), 12=376(LC 19), 13=342(LC 19), 9=372(LC 20), 8=350(LC 20)

FORCES. (lb) - Max. Comp./Max. Ten. - All forces 250 (lb) or less except when shown.

WEBS 2-13=252/186, 6-8=257/189

NOTES-

- Unbalanced roof live loads have been considered for this design.
- Wind: ASCE 7-10; Vult=130mph (3-second gust) Vasd=101mph; TCCL=4.2psf; BCDL=3.0psf; h=20ft; Cat. II; Exp B; Encl., GCpi=0.18; MWFRS (envelope) gable end zone and C-C Exterior(2) zone; C-C for members and forces & MWFRS for reactions shown; Lumber DOL=1.60 plate grip DOL=1.60
- All plates are 2x4 MT20 unless otherwise indicated.
- Gable requires continuous bottom chord bearing.
- This truss has been designed for a 10.0 psf bottom chord live load nonconcurrent with any other live loads.
- * This truss has been designed for a live load of 20.0psf on the bottom chord in all areas where a rectangle 3-6-0 tall by 2-0-0 wide will fit between the bottom chord and any other members, with BCDL = 10.0psf.
- Provide mechanical connection (by others) of truss to bearing plate capable of withstanding 100 lb uplift at joint(s) 1, 7 except (jt=lb) 12=157, 13=166, 9=154, 8=169.

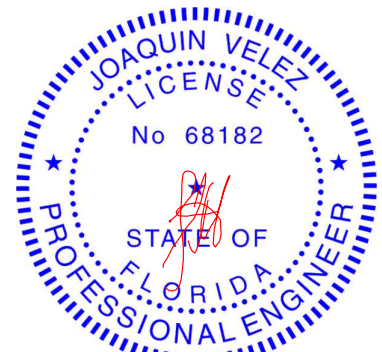

Joaquin Velez PE No.68182
MiTek USA, Inc. FL Cert 6634
6904 Parke East Blvd. Tampa FL 33610
Date:

November 5, 2020

WARNING - Verify design parameters and READ NOTES ON THIS AND INCLUDED MITEK REFERENCE PAGE MII-7473 rev. 5/19/2020 BEFORE USE.

Design valid for use only with MiTek® connectors. This design is based only upon parameters shown, and is for an individual building component, not a truss system. Before use, the building designer must verify the applicability of design parameters and properly incorporate this design into the overall building design. Bracing indicated is to prevent buckling of individual truss web and/or chord members only. Additional temporary and permanent bracing is always required for stability and to prevent collapse with possible personal injury and property damage. For general guidance regarding the fabrication, storage, delivery, erection and bracing of trusses and truss systems, see **ANSI/TPI1 Quality Criteria, DSB-89 and BCSI Building Component Safety Information** available from Truss Plate Institute, 2670 Crain Highway, Suite 203 Waldorf, MD 20601



6904 Parke East Blvd.
Tampa, FL 33610

Job 2525538	Truss V07	Truss Type Valley	Qty 1	Ply 1	AMIRA BLDRS - THOMAS RES. Job Reference (optional)	T21805065
----------------	--------------	----------------------	----------	----------	---	-----------

Builders FirstSource (Jacksonville, FL),

Jacksonville, FL - 32244,

8.240 s Mar 9 2020 MiTek Industries, Inc. Thu Nov 5 09:19:37 2020 Page 1

ID:7WKr8toudn35dxwKwBAfQtytHta-hwrXCDyFMrsM7z2MMxHdA0?Gut4fShwZX8fi0yMH3q

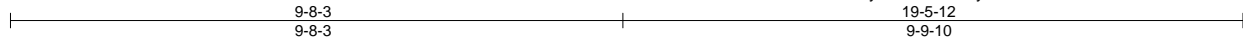

Scale = 1:36.4

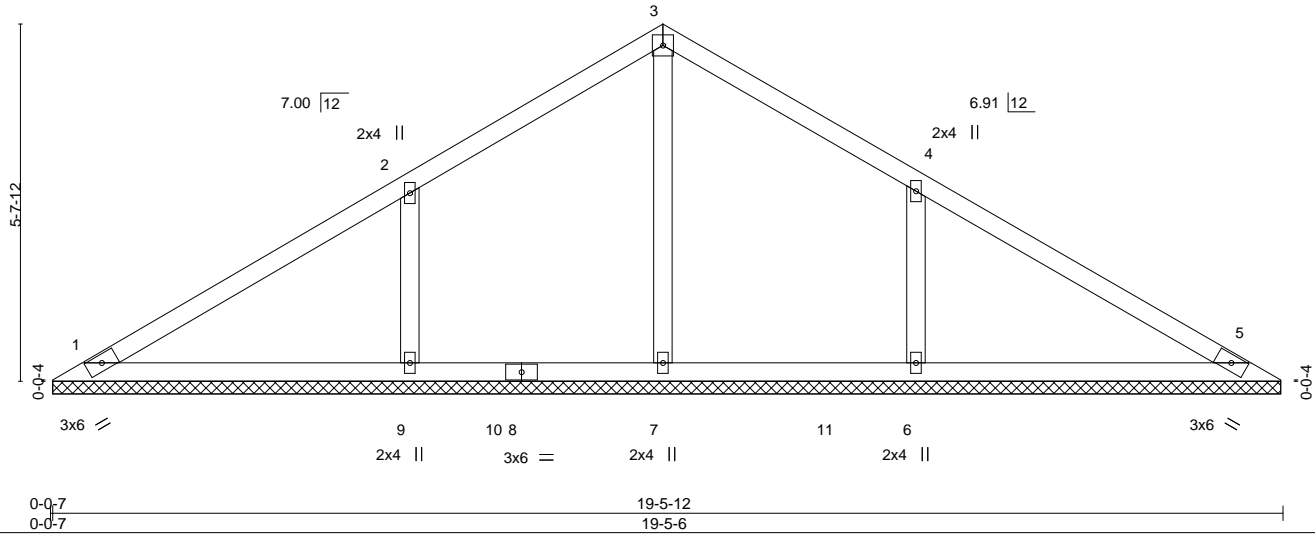

LOADING (psf)	SPACING-	CSL	DEFL.	in (loc)	l/defl	L/d	PLATES	GRIP
TCLL 20.0	2-0-0	TC 0.28	Vert(LL)	n/a	-	n/a	MT20	244/190
TCDL 7.0	Plate Grip DOL 1.25	BC 0.22	Vert(CT)	n/a	-	n/a		
BCLL 0.0 *	Lumber DOL 1.25	WB 0.08	Horz(CT)	0.00	5	n/a		
BCDL 10.0	Rep Stress Incr YES	Matrix-S						
	Code FBC2017/TPI2014						Weight: 76 lb	FT = 20%

LUMBER-
 TOP CHORD 2x4 SP No.2
 BOT CHORD 2x4 SP No.2
 OTHERS 2x4 SP No.3

BRACING-
 TOP CHORD Structural wood sheathing directly applied or 6-0-0 oc purlins.
 BOT CHORD Rigid ceiling directly applied or 10-0-0 oc bracing.

REACTIONS. All bearings 19-4-15.
 (lb) - Max Horz 1=132(LC 8)
 Max Uplift All uplift 100 lb or less at joint(s) 1, 5 except 9=-214(LC 12), 6=-215(LC 13)
 Max Grav All reactions 250 lb or less at joint(s) 1, 5 except 7=309(LC 22), 9=459(LC 19), 6=465(LC 20)

FORCES. (lb) - Max. Comp./Max. Ten. - All forces 250 (lb) or less except when shown.
WEBS 2-9=-319/235, 4-6=-322/237

- NOTES-**
- Unbalanced roof live loads have been considered for this design.
 - Wind: ASCE 7-10; Vult=130mph (3-second gust) Vasd=101mph; TCCL=4.2psf; BCDL=3.0psf; h=20ft; Cat. II; Exp B; Encl., GCpi=0.18; MWFRS (envelope) gable end zone and C-C Exterior(2) zone; C-C for members and forces & MWFRS for reactions shown; Lumber DOL=1.60 plate grip DOL=1.60
 - Gable requires continuous bottom chord bearing.
 - This truss has been designed for a 10.0 psf bottom chord live load nonconcurrent with any other live loads.
 - * This truss has been designed for a live load of 20.0psf on the bottom chord in all areas where a rectangle 3-6-0 tall by 2-0-0 wide will fit between the bottom chord and any other members, with BCDL = 10.0psf.
 - Provide mechanical connection (by others) of truss to bearing plate capable of withstanding 100 lb uplift at joint(s) 1, 5 except (jt=lb) 9=214, 6=215.

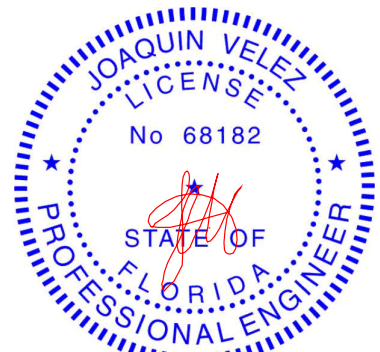

Joaquin Velez PE No.68182
 MiTek USA, Inc. FL Cert 6634
 6904 Parke East Blvd. Tampa FL 33610
 Date:

November 5, 2020

WARNING - Verify design parameters and READ NOTES ON THIS AND INCLUDED MITEK REFERENCE PAGE MII-7473 rev. 5/19/2020 BEFORE USE.

Design valid for use only with MiTek® connectors. This design is based only upon parameters shown, and is for an individual building component, not a truss system. Before use, the building designer must verify the applicability of design parameters and properly incorporate this design into the overall building design. Bracing indicated is to prevent buckling of individual truss web and/or chord members only. Additional temporary and permanent bracing is always required for stability and to prevent collapse with possible personal injury and property damage. For general guidance regarding the fabrication, storage, delivery, erection and bracing of trusses and truss systems, see **ANSI/TPI1 Quality Criteria, DSB-89 and BCSI Building Component Safety Information** available from Truss Plate Institute, 2670 Crain Highway, Suite 203 Waldorf, MD 20601



6904 Parke East Blvd.
 Tampa, FL 33610

Job 2525538	Truss V08	Truss Type Valley	Qty 1	Ply 1	AMIRA BLDRS - THOMAS RES. Job Reference (optional)	T21805066
----------------	--------------	----------------------	----------	----------	---	-----------

Builders FirstSource (Jacksonville, FL),

Jacksonville, FL - 32244,

8.240 s Mar 9 2020 MiTek Industries, Inc. Thu Nov 5 09:19:38 2020 Page 1

ID:7WKr8toudn35dxwKwBAfQtytHta-96PvQZyH7k?Dk7dYweosiEYtptSPB9V4oBuDETyMH3p

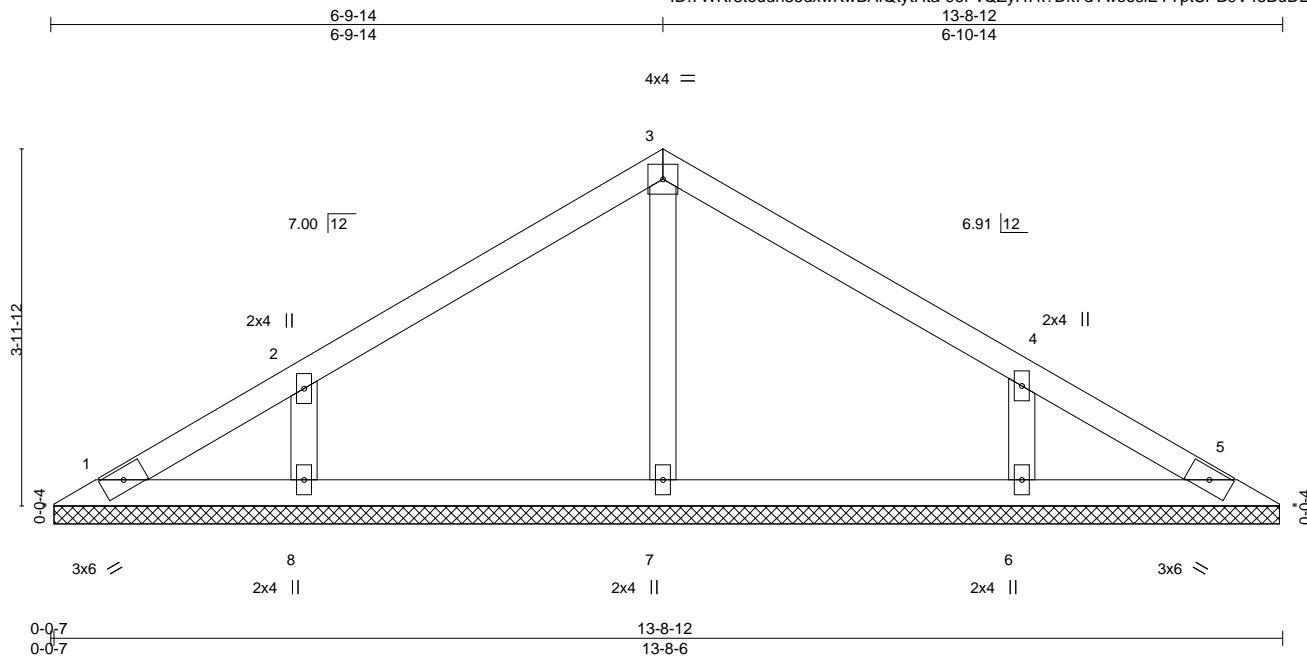

Scale = 1:25.7

LOADING (psf)	SPACING-	2-0-0	CSI.	DEFL.	in (loc)	l/defl	L/d	PLATES	GRIP	
TCLL 20.0	Plate Grip DOL	1.25	TC 0.14	Vert(LL)	n/a	-	n/a	999	MT20	244/190
TCDL 7.0	Lumber DOL	1.25	BC 0.12	Vert(CT)	n/a	-	n/a	999		
BCLL 0.0 *	Rep Stress Incr	YES	WB 0.05	Horz(CT)	0.00	5	n/a	n/a		
BCDL 10.0	Code FBC2017/TPI2014		Matrix-S						Weight: 50 lb	FT = 20%

LUMBER-

TOP CHORD 2x4 SP No.2
 BOT CHORD 2x4 SP No.2
 OTHERS 2x4 SP No.3

BRACING-

TOP CHORD Structural wood sheathing directly applied or 6-0-0 oc purlins.
 BOT CHORD Rigid ceiling directly applied or 10-0-0 oc bracing.

REACTIONS.

All bearings 13-7-15.
 (lb) - Max Horz 1=91(LC 8)
 Max Uplift All uplift 100 lb or less at joint(s) 1, 5, 7 except 8=148(LC 12), 6=148(LC 13)
 Max Grav All reactions 250 lb or less at joint(s) 1, 5 except 7=257(LC 1), 8=295(LC 19), 6=296(LC 20)

FORCES. (lb) - Max. Comp./Max. Ten. - All forces 250 (lb) or less except when shown.

NOTES-

- Unbalanced roof live loads have been considered for this design.
- Wind: ASCE 7-10; Vult=130mph (3-second gust) Vasd=101mph; TCCL=4.2psf; BCCL=3.0psf; h=20ft; Cat. II; Exp B; Encl., GCpi=0.18; MWFRS (envelope) gable end zone and C-C Exterior(2) zone; C-C for members and forces & MWFRS for reactions shown; Lumber DOL=1.60 plate grip DOL=1.60
- Gable requires continuous bottom chord bearing.
- This truss has been designed for a 10.0 psf bottom chord live load nonconcurrent with any other live loads.
- * This truss has been designed for a live load of 20.0psf on the bottom chord in all areas where a rectangle 3-6-0 tall by 2-0-0 wide will fit between the bottom chord and any other members.
- Provide mechanical connection (by others) of truss to bearing plate capable of withstanding 100 lb uplift at joint(s) 1, 5, 7 except (jt=lb) 8=148, 6=148.

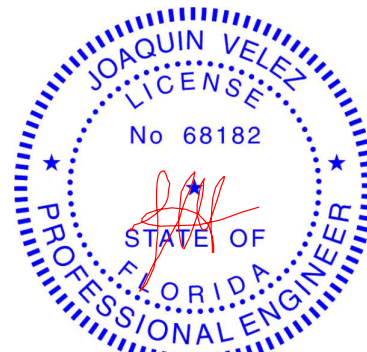

Joaquin Velez PE No.68182
 MiTek USA, Inc. FL Cert 6634
 6904 Parke East Blvd. Tampa FL 33610
 Date:

November 5, 2020

WARNING - Verify design parameters and READ NOTES ON THIS AND INCLUDED MITEK REFERENCE PAGE MII-7473 rev. 5/19/2020 BEFORE USE.

Design valid for use only with MiTek® connectors. This design is based only upon parameters shown, and is for an individual building component, not a truss system. Before use, the building designer must verify the applicability of design parameters and properly incorporate this design into the overall building design. Bracing indicated is to prevent buckling of individual truss web and/or chord members only. Additional temporary and permanent bracing is always required for stability and to prevent collapse with possible personal injury and property damage. For general guidance regarding fabrication, storage, delivery, erection and bracing of trusses and truss systems, see **ANSI/TPI1 Quality Criteria, DSB-89 and BCSI Building Component Safety Information** available from Truss Plate Institute, 2670 Crain Highway, Suite 203 Waldorf, MD 20601



6904 Parke East Blvd.
 Tampa, FL 33610

Job 2525538	Truss V09	Truss Type Valley	Qty 1	Ply 1	AMIRA BLDRS - THOMAS RES. Job Reference (optional)	T21805067
----------------	--------------	----------------------	----------	----------	---	-----------

Builders FirstSource (Jacksonville, FL),

Jacksonville, FL - 32244,

8.240 s Mar 9 2020 MiTek Industries, Inc. Thu Nov 5 09:19:40 2020 Page 1

ID:7WKr8toudn35dxwKwBAfQtytHta-5VWfrF_XfMFx_Rnx23qKofdpRg8wf3HMGVJLJyMH3n

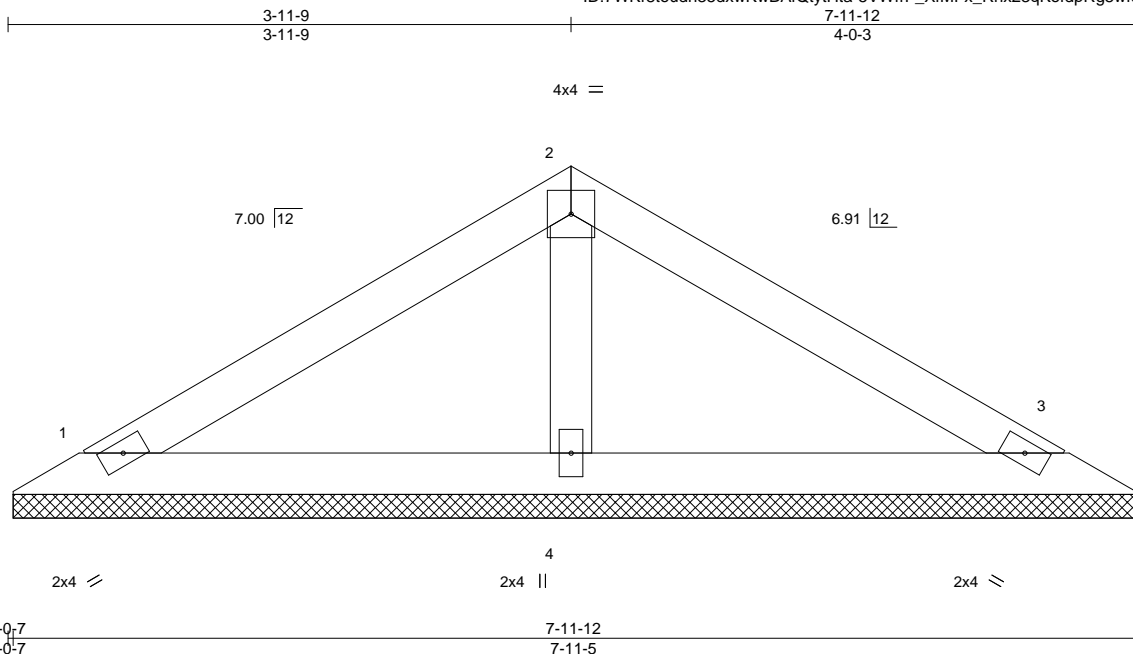

Scale = 1:16.2

LOADING (psf)	SPACING-	CSI.	DEFL.	in (loc)	l/defl	L/d	PLATES	GRIP
TCLL 20.0	2-0-0	TC 0.14	Vert(LL)	n/a	-	n/a	MT20	244/190
TCDL 7.0	Plate Grip DOL 1.25	BC 0.12	Vert(CT)	n/a	-	n/a		
BCLL 0.0 *	Lumber DOL 1.25	WB 0.03	Horz(CT)	0.00	3	n/a		
BCDL 10.0	Rep Stress Incr YES	Matrix-S					Weight: 26 lb	FT = 20%
	Code FBC2017/TPI2014							

LUMBER-
 TOP CHORD 2x4 SP No.2
 BOT CHORD 2x4 SP No.2
 OTHERS 2x4 SP No.3

BRACING-
 TOP CHORD Structural wood sheathing directly applied or 6-0-0 oc purlins.
 BOT CHORD Rigid ceiling directly applied or 10-0-0 oc bracing.

REACTIONS. (size) 1=7-10-15, 3=7-10-15, 4=7-10-15
 Max Horz 1=-49(LC 10)
 Max Uplift 1=-39(LC 12), 3=-46(LC 13), 4=-49(LC 12)
 Max Grav 1=119(LC 1), 3=121(LC 1), 4=270(LC 1)

FORCES. (lb) - Max. Comp./Max. Ten. - All forces 250 (lb) or less except when shown.

NOTES-

- Unbalanced roof live loads have been considered for this design.
- Wind: ASCE 7-10; Vult=130mph (3-second gust) Vasd=101mph; TC DL=4.2psf; BCDL=3.0psf; h=20ft; Cat. II; Exp B; Encl., GCpi=0.18; MWFRS (envelope) gable end zone and C-C Exterior(2) zone; C-C for members and forces & MWFRS for reactions shown; Lumber DOL=1.60 plate grip DOL=1.60
- Gable requires continuous bottom chord bearing.
- This truss has been designed for a 10.0 psf bottom chord live load nonconcurrent with any other live loads.
- * This truss has been designed for a live load of 20.0psf on the bottom chord in all areas where a rectangle 3-6-0 tall by 2-0-0 wide will fit between the bottom chord and any other members.
- Provide mechanical connection (by others) of truss to bearing plate capable of withstanding 100 lb uplift at joint(s) 1, 3, 4.

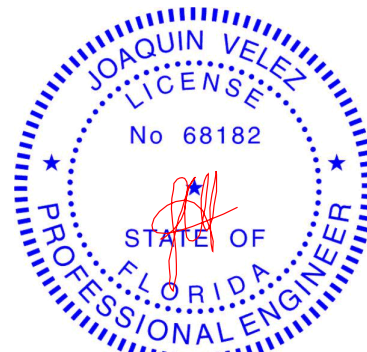

Joaquin Velez PE No.68182
 MiTek USA, Inc. FL Cert 6634
 6904 Parke East Blvd. Tampa FL 33610
 Date:

November 5, 2020

WARNING - Verify design parameters and READ NOTES ON THIS AND INCLUDED MITEK REFERENCE PAGE MII-7473 rev. 5/19/2020 BEFORE USE.

Design valid for use only with MiTek® connectors. This design is based only upon parameters shown, and is for an individual building component, not a truss system. Before use, the building designer must verify the applicability of design parameters and properly incorporate this design into the overall building design. Bracing indicated is to prevent buckling of individual truss web and/or chord members only. Additional temporary and permanent bracing is always required for stability and to prevent collapse with possible personal injury and property damage. For general guidance regarding the fabrication, storage, delivery, erection and bracing of trusses and truss systems, see **ANSI/TPI1 Quality Criteria, DSB-89 and BCSI Building Component Safety Information** available from Truss Plate Institute, 2670 Crain Highway, Suite 203 Waldorf, MD 20601



6904 Parke East Blvd.
 Tampa, FL 33610

Job 2525538	Truss V10	Truss Type Valley	Qty 1	Ply 1	AMIRA BLDRS - THOMAS RES. Job Reference (optional)	T21805068
----------------	--------------	----------------------	----------	----------	---	-----------

Builders FirstSource (Jacksonville, FL),

Jacksonville, FL - 32244,

8.240 s Mar 9 2020 MiTek Industries, Inc. Thu Nov 5 09:19:40 2020 Page 1

ID:7Wkr8toudn35dxwKwBAfQtytHta-5VWfrF_XfMFx_Rnx23qKofdprg7Rf3CMGVNJLYMH3n

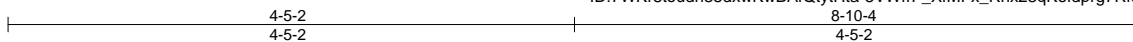

Scale = 1:18.0

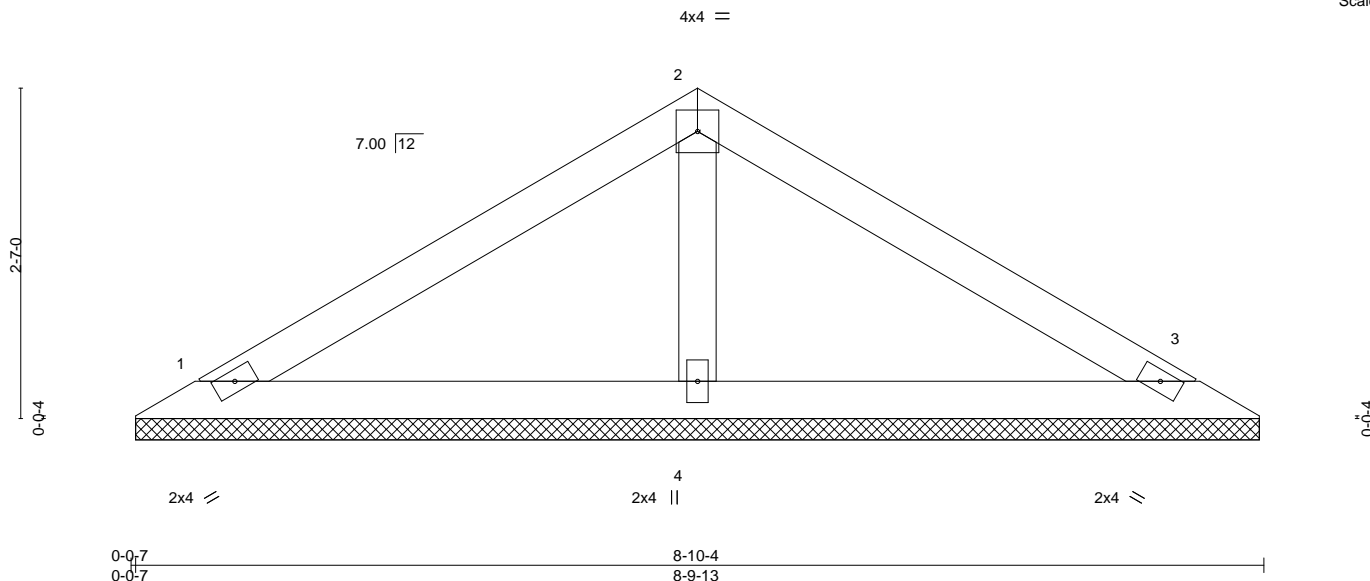

LOADING (psf)	SPACING-	CSL.	DEFL.	in (loc)	l/defl	L/d	PLATES	GRIP
TCLL 20.0	2-0-0	TC 0.17	Vert(LL)	n/a	-	n/a	MT20	244/190
TCDL 7.0	Plate Grip DOL 1.25	BC 0.15	Vert(CT)	n/a	-	n/a		
BCLL 0.0 *	Lumber DOL 1.25	WB 0.04	Horz(CT)	0.00	3	n/a		
BCDL 10.0	Rep Stress Incr YES	Matrix-S						
	Code FBC2017/TPI2014						Weight: 29 lb	FT = 20%

LUMBER-
 TOP CHORD 2x4 SP No.2
 BOT CHORD 2x4 SP No.2
 OTHERS 2x4 SP No.3

BRACING-
 TOP CHORD Structural wood sheathing directly applied or 6-0-0 oc purlins.
 BOT CHORD Rigid ceiling directly applied or 10-0-0 oc bracing.

REACTIONS. (size) 1=8-9-6, 3=8-9-6, 4=8-9-6
 Max Horz 1=-56(LC 8)
 Max Uplift 1=45(LC 12), 3=-52(LC 13), 4=-56(LC 12)
 Max Grav 1=135(LC 1), 3=135(LC 1), 4=304(LC 1)

FORCES. (lb) - Max. Comp./Max. Ten. - All forces 250 (lb) or less except when shown.

NOTES-

- 1) Unbalanced roof live loads have been considered for this design.
- 2) Wind: ASCE 7-10; Vult=130mph (3-second gust) Vasd=101mph; TCCL=4.2psf; BCCL=3.0psf; h=20ft; Cat. II; Exp B; Encl., GCpi=0.18; MWFRS (envelope) gable end zone and C-C Exterior(2) zone; C-C for members and forces & MWFRS for reactions shown; Lumber DOL=1.60 plate grip DOL=1.60
- 3) Gable requires continuous bottom chord bearing.
- 4) This truss has been designed for a 10.0 psf bottom chord live load nonconcurrent with any other live loads.
- 5) * This truss has been designed for a live load of 20.0psf on the bottom chord in all areas where a rectangle 3-6-0 tall by 2-0-0 wide will fit between the bottom chord and any other members.
- 6) Provide mechanical connection (by others) of truss to bearing plate capable of withstanding 100 lb uplift at joint(s) 1, 3, 4.

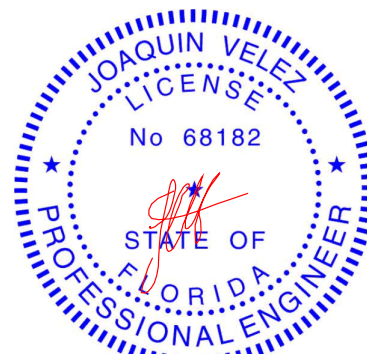

Joaquin Velez PE No.68182
 MiTek USA, Inc. FL Cert 6634
 6904 Parke East Blvd. Tampa FL 33610
 Date:

November 5, 2020

WARNING - Verify design parameters and READ NOTES ON THIS AND INCLUDED MITEK REFERENCE PAGE MII-7473 rev. 5/19/2020 BEFORE USE.

Design valid for use only with MiTek® connectors. This design is based only upon parameters shown, and is for an individual building component, not a truss system. Before use, the building designer must verify the applicability of design parameters and properly incorporate this design into the overall building design. Bracing indicated is to prevent buckling of individual truss web and/or chord members only. Additional temporary and permanent bracing is always required for stability and to prevent collapse with possible personal injury and property damage. For general guidance regarding the fabrication, storage, delivery, erection and bracing of trusses and truss systems, see **ANSI/TPI1 Quality Criteria, DSB-89 and BCSI Building Component Safety Information** available from Truss Plate Institute, 2670 Crain Highway, Suite 203 Waldorf, MD 20601



6904 Parke East Blvd.
 Tampa, FL 33610

Job 2525538	Truss V11	Truss Type Valley	Qty 1	Ply 1	AMIRA BLDRS - THOMAS RES. Job Reference (optional)	T21805069
----------------	--------------	----------------------	----------	----------	---	-----------

Builders FirstSource (Jacksonville, FL),

Jacksonville, FL - 32244,

8.240 s Mar 9 2020 MiTek Industries, Inc. Thu Nov 5 09:19:42 2020 Page 1

ID:7WKr8toudn35dxwKwBAfQytHta-2ueQGw0nBzVfDkxJ9Utot4iBHUoV7ZIfjpsQNEyMH3I

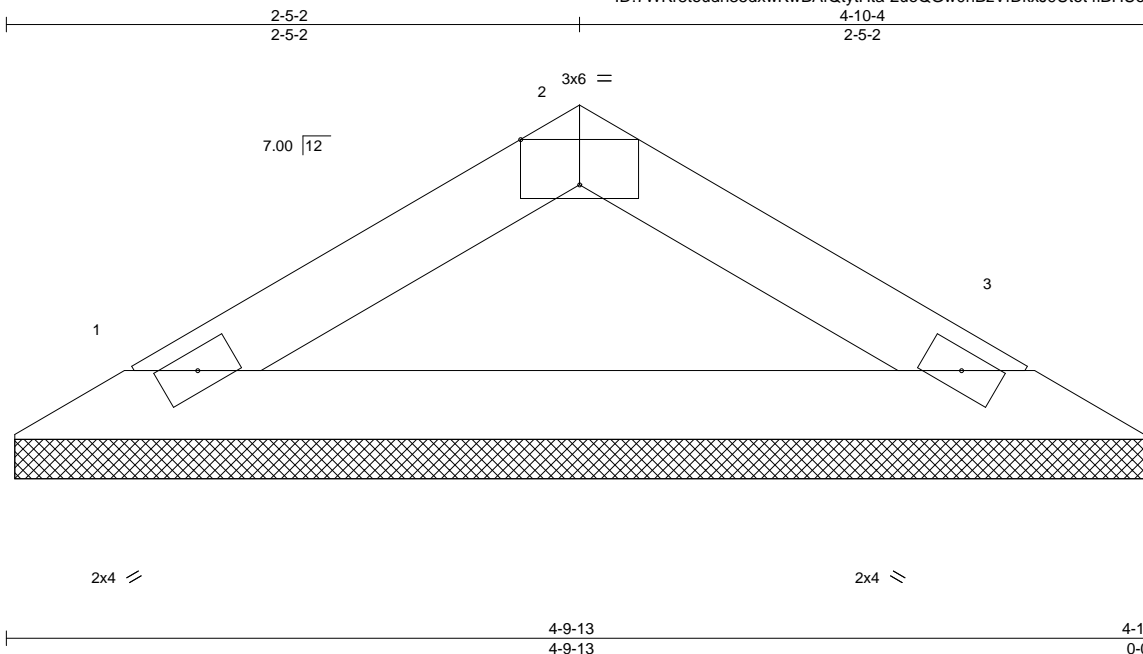

Scale = 1:9.8

LOADING (psf)	SPACING-	2-0-0	CSI.	DEFL.	in (loc)	l/defl	L/d	PLATES	GRIP
TCLL 20.0	Plate Grip DOL	1.25	TC 0.05	Vert(LL)	n/a	-	n/a	MT20	244/190
TCDL 7.0	Lumber DOL	1.25	BC 0.17	Vert(CT)	n/a	-	n/a		
BCLL 0.0 *	Rep Stress Incr	YES	WB 0.00	Horz(CT)	0.00	3	n/a		
BCDL 10.0	Code	FBC2017/TPI2014	Matrix-P					Weight: 14 lb	FT = 20%

LUMBER-

TOP CHORD 2x4 SP No.2
BOT CHORD 2x4 SP No.2

BRACING-

TOP CHORD Structural wood sheathing directly applied or 4-10-4 oc purlins.
BOT CHORD Rigid ceiling directly applied or 10-0-0 oc bracing.

REACTIONS.

(size) 1=4-9-6, 3=4-9-6
Max Horz 1=-27(LC 8)
Max Uplift 1=-35(LC 12), 3=-35(LC 13)
Max Grav 1=140(LC 1), 3=140(LC 1)

FORCES. (lb) - Max. Comp./Max. Ten. - All forces 250 (lb) or less except when shown.

NOTES-

- Unbalanced roof live loads have been considered for this design.
- Wind: ASCE 7-10; Vult=130mph (3-second gust) Vasd=101mph; TC DL=4.2psf; BC DL=3.0psf; h=20ft; Cat. II; Exp B; Encl., GCpi=0.18; MWFRS (envelope) gable end zone and C-C Exterior(2) zone; C-C for members and forces & MWFRS for reactions shown; Lumber DOL=1.60 plate grip DOL=1.60
- Gable requires continuous bottom chord bearing.
- This truss has been designed for a 10.0 psf bottom chord live load nonconcurrent with any other live loads.
- * This truss has been designed for a live load of 20.0psf on the bottom chord in all areas where a rectangle 3-6-0 tall by 2-0-0 wide will fit between the bottom chord and any other members.
- Provide mechanical connection (by others) of truss to bearing plate capable of withstanding 100 lb uplift at joint(s) 1, 3.

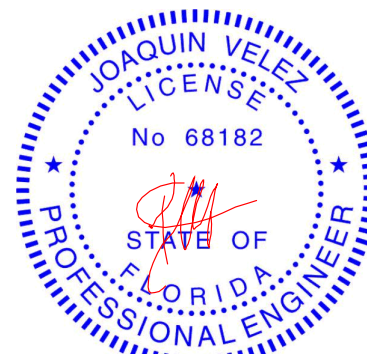

Joaquin Velez PE No.68182
MiTek USA, Inc. FL Cert 6634
6904 Parke East Blvd. Tampa FL 33610
Date:

November 5, 2020

WARNING - Verify design parameters and READ NOTES ON THIS AND INCLUDED MITEK REFERENCE PAGE MII-7473 rev. 5/19/2020 BEFORE USE.

Design valid for use only with MiTek® connectors. This design is based only upon parameters shown, and is for an individual building component, not a truss system. Before use, the building designer must verify the applicability of design parameters and properly incorporate this design into the overall building design. Bracing indicated is to prevent buckling of individual truss web and/or chord members only. Additional temporary and permanent bracing is always required for stability and to prevent collapse with possible personal injury and property damage. For general guidance regarding the fabrication, storage, delivery, erection and bracing of trusses and truss systems, see **ANSI/TPI1 Quality Criteria, DSB-89 and BCSI Building Component Safety Information** available from Truss Plate Institute, 2670 Crain Highway, Suite 203 Waldorf, MD 20601



6904 Parke East Blvd.
Tampa, FL 36610

Job 2525538	Truss V12	Truss Type Valley	Qty 1	Ply 1	AMIRA BLDRS - THOMAS RES. T21805070
----------------	--------------	----------------------	----------	----------	--

Builders FirstSource (Jacksonville, FL),

Jacksonville, FL - 32244,

8.240 s Mar 9 2020 MiTek Industries, Inc. Thu Nov 5 09:19:43 2020 Page 1

ID:7WKr8toudn35dxwKwBAfQtytHta-W4CoTG0PyHdWruWWjBO1PHFLJuASsQFpyTb_vgyMH3k

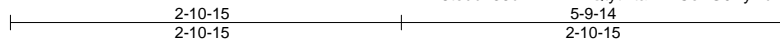

Scale = 1:17.2

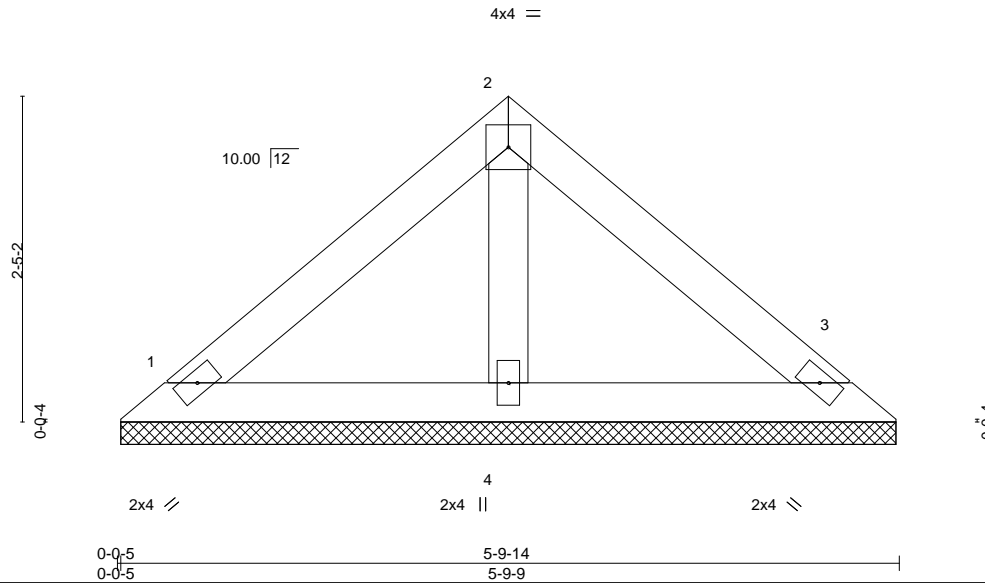

LOADING (psf)	SPACING-	CSI.	DEFL.	in (loc)	l/defl	L/d	PLATES	GRIP
TCLL 20.0	2-0-0	TC 0.10	Vert(LL)	n/a	-	n/a	MT20	244/190
TCDL 7.0	Plate Grip DOL 1.25	BC 0.06	Vert(CT)	n/a	-	n/a		
BCLL 0.0 *	Lumber DOL 1.25	WB 0.02	Horz(CT)	0.00	3	n/a		
BCDL 10.0	Rep Stress Incr YES	Matrix-P						
	Code FBC2017/TPI2014						Weight: 21 lb	FT = 20%

LUMBER-

TOP CHORD 2x4 SP No.2
 BOT CHORD 2x4 SP No.2
 OTHERS 2x4 SP No.3

BRACING-

TOP CHORD Structural wood sheathing directly applied or 5-9-14 oc purlins.
 BOT CHORD Rigid ceiling directly applied or 10-0-0 oc bracing.

REACTIONS.

(size) 1=5-9-4, 3=5-9-4, 4=5-9-4
 Max Horz 1=52(LC 8)
 Max Uplift 1=36(LC 13), 3=42(LC 13), 4=15(LC 12)
 Max Grav 1=106(LC 1), 3=106(LC 1), 4=160(LC 1)

FORCES. (lb) - Max. Comp./Max. Ten. - All forces 250 (lb) or less except when shown.

NOTES-

- Unbalanced roof live loads have been considered for this design.
- Wind: ASCE 7-10; Vult=130mph (3-second gust) Vasd=101mph; TCDL=4.2psf; BCDL=3.0psf; h=20ft; Cat. II; Exp B; Encl., GCpi=0.18; MWFRS (envelope) gable end zone and C-C Exterior(2) zone; C-C for members and forces & MWFRS for reactions shown; Lumber DOL=1.60 plate grip DOL=1.60
- Gable requires continuous bottom chord bearing.
- This truss has been designed for a 10.0 psf bottom chord live load nonconcurrent with any other live loads.
- * This truss has been designed for a live load of 20.0psf on the bottom chord in all areas where a rectangle 3-6-0 tall by 2-0-0 wide will fit between the bottom chord and any other members.
- Provide mechanical connection (by others) of truss to bearing plate capable of withstanding 100 lb uplift at joint(s) 1, 3, 4.

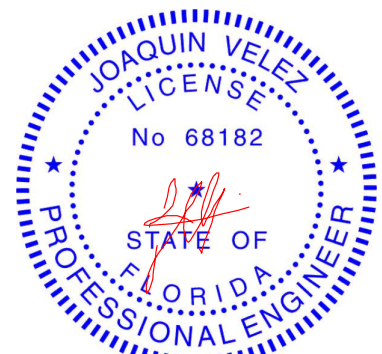

Joaquin Velez PE No.68182
 MiTek USA, Inc. FL Cert 6634
 6904 Parke East Blvd. Tampa FL 33610
 Date:

November 5, 2020

WARNING - Verify design parameters and READ NOTES ON THIS AND INCLUDED MITEK REFERENCE PAGE MII-7473 rev. 5/19/2020 BEFORE USE.

Design valid for use only with MiTek® connectors. This design is based only upon parameters shown, and is for an individual building component, not a truss system. Before use, the building designer must verify the applicability of design parameters and properly incorporate this design into the overall building design. Bracing indicated is to prevent buckling of individual truss web and/or chord members only. Additional temporary and permanent bracing is always required for stability and to prevent collapse with possible personal injury and property damage. For general guidance regarding the fabrication, storage, delivery, erection and bracing of trusses and truss systems, see **ANSI/TPI1 Quality Criteria, DSB-89 and BCSI Building Component Safety Information** available from Truss Plate Institute, 2670 Crain Highway, Suite 203 Waldorf, MD 20601



6904 Parke East Blvd.
 Tampa, FL 33610

Job 2525538	Truss V13	Truss Type Valley	Qty 1	Ply 1	AMIRA BLDRS - THOMAS RES. T21805071
----------------	--------------	----------------------	----------	----------	--

Builders FirstSource (Jacksonville, FL),

Jacksonville, FL - 32244,

8.240 s Mar 9 2020 MiTek Industries, Inc. Thu Nov 5 09:19:44 2020 Page 1

ID:7WKr8toudn35dxwKwBAfQtytHta-_GmAgc12iaINS24iHvVnXFHWpbntnyA7LXS6yMH3j

Job Reference (optional)

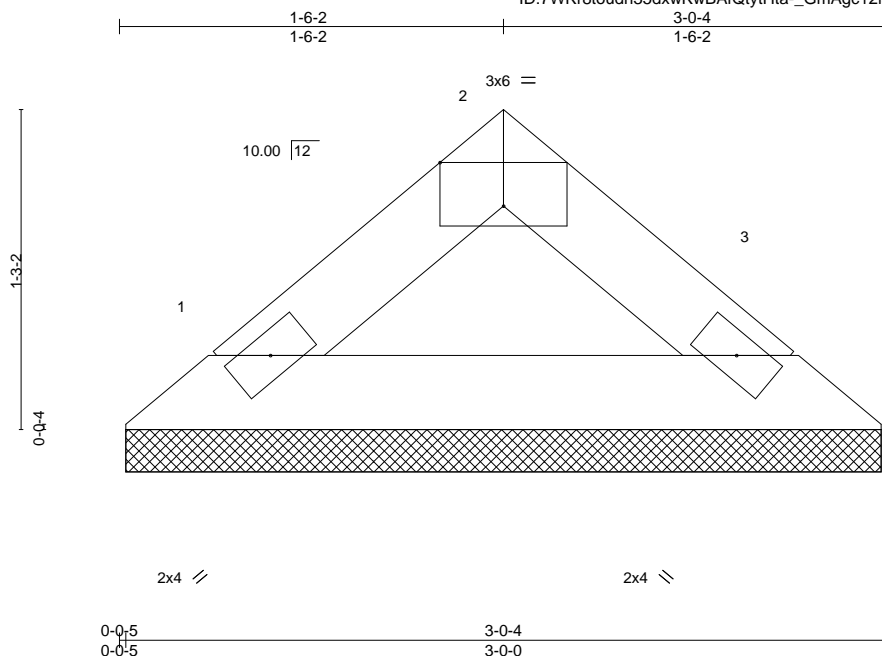

Scale = 1:9.1

Plate Offsets (X,Y)--	[2:0-3-0,Edge]							
LOADING (psf)	SPACING-	2-0-0	CSI.	DEFL.	in	(loc)	l/defl	L/d
TCLL 20.0	Plate Grip DOL	1.25	TC 0.02	Vert(LL)	n/a	-	n/a	999
TCDL 7.0	Lumber DOL	1.25	BC 0.06	Vert(CT)	n/a	-	n/a	999
BCLL 0.0 *	Rep Stress Incr	YES	WB 0.00	Horz(CT)	0.00	3	n/a	n/a
BCDL 10.0	Code FBC2017/TPI2014		Matrix-P					
								PLATES
								MT20
								GRIP
								244/190
								Weight: 9 lb
								FT = 20%

LUMBER-

TOP CHORD 2x4 SP No.2
BOT CHORD 2x4 SP No.2

BRACING-

TOP CHORD Structural wood sheathing directly applied or 3-0-4 oc purlins.
BOT CHORD Rigid ceiling directly applied or 10-0-0 oc bracing.

REACTIONS. (size) 1=2-11-11, 3=2-11-11

Max Horz 1=-23(LC 8)
Max Uplift 1=-19(LC 12), 3=-19(LC 13)
Max Grav 1=82(LC 1), 3=82(LC 1)

FORCES. (lb) - Max. Comp./Max. Ten. - All forces 250 (lb) or less except when shown.

NOTES-

- Unbalanced roof live loads have been considered for this design.
- Wind: ASCE 7-10; Vult=130mph (3-second gust) Vasd=101mph; TCDL=4.2psf; BCDL=3.0psf; h=20ft; Cat. II; Exp B; Encl., GCpi=0.18; MWFRS (envelope) gable end zone and C-C Exterior(2) zone; C-C for members and forces & MWFRS for reactions shown; Lumber DOL=1.60 plate grip DOL=1.60
- Gable requires continuous bottom chord bearing.
- This truss has been designed for a 10.0 psf bottom chord live load nonconcurrent with any other live loads.
- * This truss has been designed for a live load of 20.0psf on the bottom chord in all areas where a rectangle 3-6-0 tall by 2-0-0 wide will fit between the bottom chord and any other members.
- Provide mechanical connection (by others) of truss to bearing plate capable of withstanding 100 lb uplift at joint(s) 1, 3.

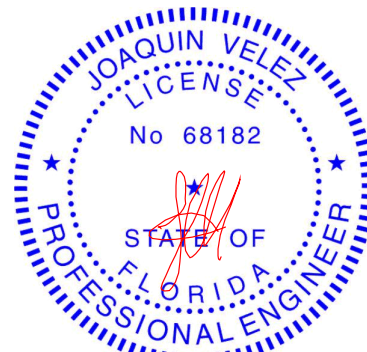

Joaquin Velez PE No.68182
MiTek USA, Inc. FL Cert 6634
6904 Parke East Blvd. Tampa FL 33610
Date:

November 5, 2020

WARNING - Verify design parameters and READ NOTES ON THIS AND INCLUDED MITEK REFERENCE PAGE MII-7473 rev. 5/19/2020 BEFORE USE.

Design valid for use only with MiTek® connectors. This design is based only upon parameters shown, and is for an individual building component, not a truss system. Before use, the building designer must verify the applicability of design parameters and properly incorporate this design into the overall building design. Bracing indicated is to prevent buckling of individual truss web and/or chord members only. Additional temporary and permanent bracing is always required for stability and to prevent collapse with possible personal injury and property damage. For general guidance regarding the fabrication, storage, delivery, erection and bracing of trusses and truss systems, see **ANSI/TPI1 Quality Criteria, DSB-89 and BCSI Building Component Safety Information** available from Truss Plate Institute, 2670 Crain Highway, Suite 203 Waldorf, MD 20601



6904 Parke East Blvd.
Tampa, FL 33610

Symbols

PLATE LOCATION AND ORIENTATION

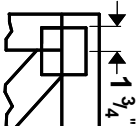

Center plate on joint unless x, y offsets are indicated. Dimensions are in ft-in-sixteenths. Apply plates to both sides of truss and fully embed teeth.

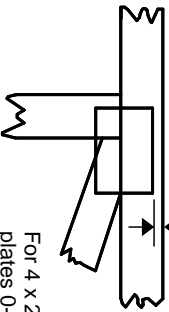

For 4 x 2 orientation, locate plates 0- 1/16" from outside edge of truss.



This symbol indicates the required direction of slots in connector plates.

* Plate location details available in **MITek 20/20 software** or upon request.

PLATE SIZE

4 X 4

The first dimension is the plate width measured perpendicular to slots. Second dimension is the length parallel to slots.

LATERAL BRACING LOCATION



Indicated by symbol shown and/or by text in the bracing section of the output. Use T or I bracing if indicated.

BEARING

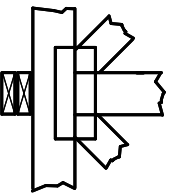

Indicates location where bearings (supports) occur. Icons vary but reaction section indicates joint number where bearings occur. Min size shown is for crushing only.

Industry Standards:

ANSI/TP1: National Design Specification for Metal Plate Connected Wood Truss Construction.
DSB-89: Design Standard for Bracing, Building Component Safety Information, Guide to Good Practice for Handling, Installing & Bracing of Metal Plate Connected Wood Trusses.

Numbering System

6-4-8 dimensions shown in ft-in-sixteenths (Drawings not to scale)

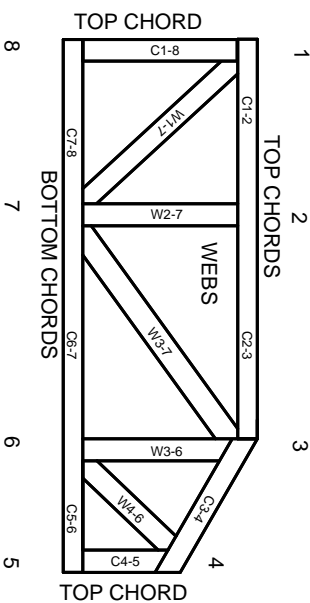

JOINTS ARE GENERALLY NUMBERED/LETTERED CLOCKWISE AROUND THE TRUSS STARTING AT THE JOINT FARTHEST TO THE LEFT.

CHORDS AND WEBS ARE IDENTIFIED BY END JOINT NUMBERS/LETTERS.

PRODUCT CODE APPROVALS

ICC-ES Reports:

ESR-1311, ESR-1352, ESR1988
ER-3907, ESR-2362, ESR-1397, ESR-3282

Trusses are designed for wind loads in the plane of the truss unless otherwise shown.

Lumber design values are in accordance with ANSI/TP1 section 6.3 These truss designs rely on lumber values established by others.

© 2012 MITek® All Rights Reserved

General Safety Notes

Failure to Follow Could Cause Property Damage or Personal Injury

1. Additional stability bracing for truss system, e.g. diagonal or X-bracing, is always required. See BCSI.
2. Truss bracing must be designed by an engineer. For wide truss spacing, individual lateral braces themselves may require bracing, or alternative Tor I bracing should be considered.
3. Never exceed the design loading shown and never stack materials on inadequately braced trusses.
4. Provide copies of this truss design to the building designer, erection supervisor, property owner and all other interested parties.
5. Cut members to bear tightly against each other.
6. Place plates on each face of truss at each joint and embed fully. Knots and wane at joint locations are regulated by ANSI/TP1.
7. Design assumes trusses will be suitably protected from the environment in accord with ANSI/TP1.
8. Unless otherwise noted, moisture content of lumber shall not exceed 19% at time of fabrication.
9. Unless expressly noted, this design is not applicable for use with fire retardant, preservative treated, or green lumber.
10. Camber is a non-structural consideration and is the responsibility of truss fabricator. General practice is to camber for dead load deflection.
11. Plate type, size, orientation and location dimensions indicated are minimum plating requirements.
12. Lumber used shall be of the species and size, and in all respects, equal to or better than that specified.
13. Top chords must be sheathed or purlins provided at spacing indicated on design.
14. Bottom chords require lateral bracing at 10 ft. spacing, or less, if no ceiling is installed, unless otherwise noted.
15. Connections not shown are the responsibility of others.
16. Do not cut or alter truss member or plate without prior approval of an engineer.
17. Install and load vertically unless indicated otherwise.
18. Use of green or treated lumber may pose unacceptable environmental, health or performance risks. Consult with project engineer before use.
19. Review all portions of this design (front, back, words and pictures) before use. Reviewing pictures alone is not sufficient.
20. Design assumes manufacture in accordance with ANSI/TP1 Quality Criteria.
21. The design does not take into account any dynamic or other loads other than those expressly stated.



MITek Engineering Reference Sheet: Mill-7473 rev. 5/19/2020