

**BOARD OF COUNTY COMMISSIONERS**

**REGULAR MEETING**

**SCHOOL BOARD ADMINISTRATIVE COMPLEX**

**372 WEST DUVAL STREET**

**March 21, 2024 at 5:30 PM**

**CONSENT AGENDA**

---

- (1) BA 24-29 - Friends of the Library Donation and Florida Department of Management Services Disbursement (pg. 1)**
- (2) BCC Administration - Meeting Minutes - Regular Meeting - 12/7/2023 (pg. 7)**
- (3) BCC Administration - Meeting Minutes - Regular Meeting - 02/15/2024 (pg. 16)**
- (4) BCC Administration - Release of Lien - Lance Leguire (pg. 24)**
- (5) BCC Finance - BA 24-31 - Ellisville Wastewater Treatment Plant Final - \$7,125 (pg. 30)**
- (6) BCC Finance - Bills and Vouchers - 3/13/24 - \$3,759,195 (pg. 31)**
- (7) Public Works - BA 24-32 - Budget Amendment Mosquito Control Carry-Forward from FY22/23 to FY23/24 (pg. 45)**
- (8) Public Works - Utility Permit from Comcast Requesting to Run a Cable Along SE County Road 252 (pg. 51)**
- (9) Public Works - Utility Permit from Duke Energy Requesting to Replace a Pole on SW Holsein Ave (pg. 59)**





## COLUMBIA COUNTY BOARD OF COUNTY COMMISSIONERS AGENDA ITEM REQUEST FORM

The Board of County Commissioners meets the 1st and 3rd Thursday of each month in the Columbia County School Board Administrative Complex Auditorium, 372 West Duval Street, Lake City, Florida 32055. The first meeting of every month is at 9:30AM while the second meeting of every month takes place at 5:30PM. All agenda items are due in the Board's office one week prior to the meeting date.

Today's Date: 3/12/2024 Meeting Date: 3/21/2024

Department: Library

**1. Nature and purpose of agenda item:**

BA 24-29 To distribute \$8,609.00 donated to the Library by the Friends of the Library, \$46.75 reimbursed to the Library by the Friends of the Library, and \$1,045.52 disbursed to the Library by the Department of Management Services, to the appropriate lines in the Library's budget.

**2. Recommended Motion/Action:**

Recommend approval BA 24-29

**3. Fiscal impact on current budget.**

This item is not budgeted. The proposed budget amendment to fund this request is provided below. The budget amendment number is BA 24-29 using fund(s) 104-LIBRARY ENHANCEMENT.

FROM:	TO:	AMOUNT:
104-0000-366.20-00 CONTRIBUTIONS/	104-7102-571.30-31 OPERATING EXPENDITURES/PROFESSIONAL SERVICES	\$1,500.00
104-0000-366.20-00 CONTRIBUTIONS/	104-7102-571.30-52 OPERATING EXPENDITURES/OPERATING SUPPLIES	\$3,500.00
104-0000-366.20-00 CONTRIBUTIONS/	104-7160-571.30-54 OPERATING EXPENDITURES/SUBSCRIPTIONS & DUES	\$1,109.00
104-0000-366.20-00 CONTRIBUTIONS/	104-7110-571.30-49 OPERATING EXPENDITURES/OTHER CHARGES	\$500.00
104-0000-366.20-00 CONTRIBUTIONS/	104-7100-571.30-68 OPERATING EXPENDITURES/AUDIOVISUAL	\$1,000.00
104-0000-366.20-00 CONTRIBUTIONS/	104-7110-571.30-68 OPERATING EXPENDITURES/AUDIOVISUAL	\$500.00
104-0000-366.20-00 CONTRIBUTIONS/	104-7150-571.30-68 OPERATING EXPENDITURES/AUDIOVISUAL	\$500.00
104-0000-366.20-00 CONTRIBUTIONS/	104-7100-571.30-42 OPERATING EXPENDITURES/POSTAGE	\$11.00
104-0000-366.20-00 CONTRIBUTIONS/	104-7100-571.30-47 OPERATING EXPENDITURES/PRINTING & LEGAL ADS	\$36.00
104-0000-369.20-00 MISC REVENUE/	104-7100-571.30-41 OPERATING EXPENDITURES/COMMUNICATIONS	\$305.00
104-0000-369.20-00 MISC REVENUE/	104-7150-571.30-41 OPERATING EXPENDITURES/COMMUNICATIONS	\$305.00
104-0000-369.20-00 MISC REVENUE/	104-7110-571.30-41 OPERATING EXPENDITURES/COMMUNICATIONS	\$435.00

**Columbia County Public Library**  
**308 NW Columbia Avenue**  
**Lake City, FL 32055**  
**386-758-1018 \* 386-758-2135 Fax**

**Katrina P. Evans, Library Director**

**MEMORANDUM**

DATE: March 12, 2024

TO: David Kraus, County Manager

FR: Katrina Evans, Library Director

RE: Budget Amendment

---

The attached budget amendment is to distribute \$8609.00 donated to the Library by the Friends of the Library and \$46.75 reimbursed to the Library by the Friends of the Library to the appropriate lines in the Library's budget. The Friends of the Library donated \$1500.00 for the Children's Summer Reading Program performers, \$2000.00 for children's program supplies, \$1000.00 for the purchase of neck wallets distributed to children getting their first library cards, \$500.00 for seed library supplies, \$2000.00 for WonderBooks (children's books with both book and audio components) for all three library locations, \$500.00 for StoryWalk<sup>®</sup> supplies, and \$1109.00 for the renewal of our Movie License which covers all three library locations. They also reimbursed the Library \$11.07 for postage and \$35.68 for printing.

In addition, the budget amendment also distributes \$1045.52, disbursed by the Department of Management Services to cover a portion of the local match share of E-rate for libraries in Fiscally Constrained Counties, to the appropriate lines in the Library's budget.

If you need any further information from me, please let me know. Thank you for your consideration.

LIBRARY DEPOSIT RECONCILIATION

By: F. Doyle

DEPOSIT SLIP DATE: 3/8/2024

		CASH/CHECK	CREDIT CARD (PAYGOV)	CASH REFUNDS	TOTAL
104.0000.352.1000	FINES				\$ -
104.0000.347.1002	FEES				\$ -
104.0000.347.1003	PRINT				\$ -
104.0000.366.2000	DONATION	\$ 8,609.00			\$ 8,609.00
104.7100.571.3049	OVER/SHORT				\$ -
DATE DEPOSITED: <u>3/8/2024</u>					
104.0000.352.2000	FINES				\$ -
104.0000.347.2002	FEES				\$ -
104.0000.347.2003	PRINT				\$ -
104.7110.571.3049	OVER/SHORT				\$ -
DATE DEPOSITED: _____					
104.0000.352.3000	FINES				\$ -
104.0000.347.3002	FEES				\$ -
104.0000.347.3003	PRINT				\$ -
104.7150.571.3049	OVER/SHORT				\$ -
DATE DEPOSITED: _____					
	TOTAL BY PAYMENT TYPE	\$ 8,609.00	\$ -	\$ -	\$ 8,609.00

# Columbia County Public Library

308 NW Columbia Avenue

Lake City, Florida 32055

386-758-2101 \* FAX 386-758-2135

Date: March 1, 2024

To: Friends of the Library

From: Katrina Evans

Re: Funding Requests

Below is a brief summary of upcoming Library programs and activities for which Library staff would like to request funding from the Friends of the Library. If you have any questions about specific items, please let me know.

Description of Funding Request	Staff Member Requesting Funds/Friends Budget Fund	Amount
1. Children's Summer Reading Program performers for Main Library	Kate Duong/5320.1	\$900.00
2. Children's Summer Reading Program performers for Fort White Branch Library	Kate Duong/5320.2	\$300.00
3. Children's Summer Reading Program performers for West Branch Library	Kate Duong/5320.3	\$300.00
4. Program Supplies and Neck Wallets	Kate Duong/5329	\$3000.00
5. Movie License Renewal	Katrina Evans/5310.1 5310.2 5310.3	\$559.00 \$275.00 \$275.00
6. Fort White Garden / Seed Library Supplies	Katrina Evans/2005	\$500.00
7. StoryWalk® Supplies	Kate Duong/5330.42	\$500.00
8. WonderBooks for All Three Library Locations	Kate Duong/5330.41	\$2000.00
<b>Total Funds Requested</b> <b>Payable to: Columbia County Public Library</b>		<b>\$8609.00</b>

**Friends of the  
Columbia County Public Library**

Report for 01/01/2023 – 12/31/2023

**Memorials** 2007 104-7100-571.30-66

---

• Memorials \$0.00

=====

**Total** \$0.00

**Postage** 5101 104-7100-571-30-42

---

• Postage Meter: 01/01/2023 – 12/31/2023 \$11.07

=====

**Total** \$11.07

**Photocopies** 5102 104-7100-571.30-47

---

Copies: 01/01/2023 – 12-31/2023 – (892 @ \$.04) \$35.68

=====

**Total** \$35.68

**GRAND TOTAL** \$ 46.75

DATE	1/18/2024	DOLLARS	46	CENTS	75
CURRENCY					
COINS					
TOTAL CASH					
CHECKS	46.75				
1	Friends of				
2	the Library				
3					
4					
5					
6					
7					
8					
9					
10					
11					
12					
13					
14					
15					
16					
17					
18					
19					
20					
21					
22					
23					
24					
25					
26					
27					
28					
TOTAL FROM OTHER SIDE OR ATTACHED LIST					
PLEASE RE-ENTER TOTAL HERE					46.75

**DEPOSIT TICKET**  
TOTAL ITEMS

DEPOSITS MAY NOT BE AVAILABLE FOR IMMEDIATE WITHDRAWAL.

63-8448/2631  
006

COLUMBIA COUNTY BOARD OF COUNTY COMMISSIONERS  
LIBRARY  
PO BOX 1529  
LAKE CITY, FL 32056-1529



\$

46.75

**From:** Filloon, Ann [<mailto:Ann.Filloon@dms.fl.gov>]

**Sent:** Tuesday, December 12, 2023 4:04 PM

**To:** Katrina Evans <[keyans@columbiacountyfla.com](mailto:keyans@columbiacountyfla.com)>

**Cc:** Filloon, Ann <[Ann.Filloon@dms.fl.gov](mailto:Ann.Filloon@dms.fl.gov)>

**Subject:** E-Rate Fiscally Constrained Counties Disbursement from Department of Management Services - Columbia BOCC

Katrina,

The 2023 Florida Legislature appropriated funds for the Department of Management Services to cover a portion of the local match share of E-Rate for schools and libraries in Fiscally Constrained Counties. All E-Rate applications in fiscally constrained counties that have received FCDLs (Funding Commitment Decision Letters) for FY2023/24 are receiving funds. This disbursement is approximately three fourths of the total amount that will be paid for FY2023/24. There will be another distribution of funds before June 30, 2023. These funds may be spent on allowable operating expenditures.

This payment of \$1,045.52 for the following funded FRNs should be received in December.

2399013333

2399013354

2399013363

Please let me know if you have any questions.

Ann Filloon | Chief Financial Operations

*Division of Telecommunications*

(850) 921-6481 (Office) | (850) 688-4133 (Mobile)

Florida Department of Management Services

**We Serve Those Who Serve Florida**





**COLUMBIA COUNTY BOARD OF COUNTY COMMISSIONERS  
AGENDA ITEM REQUEST FORM**

The Board of County Commissioners meets the 1st and 3rd Thursday of each month in the Columbia County School Board Administrative Complex Auditorium, 372 West Duval Street, Lake City, Florida 32055. The first meeting of every month is at 9:30AM while the second meeting of every month takes place at 5:30PM. All agenda items are due in the Board's office one week prior to the meeting date.

Today's Date: 3/6/2024 Meeting Date: 3/21/2024

Department: BCC Administration

**1. Nature and purpose of agenda item:**

Meeting Minutes 12-7-23

**2. Recommended Motion/Action:**

Approve

**3. Fiscal impact on current budget.**

This item has no effect on the current budget.

Columbia County  
Board of County Commissioners

Minutes of  
**December 7, 2023**

The Columbia County Board of County Commissioners met in a regular scheduled meeting in the auditorium of the School Board Administrative Complex at 9:33 a.m. The meeting opened with prayer and the Pledge of Allegiance to the Flag of the United States of America followed.

Commissioners in Attendance: Chairman Ronald Williams, Timothy Murphy, Robby Hollingsworth, Everett Phillips and Rocky Ford

Others in Attendance: County Manager David Kraus (“CM”)  
Assistant County Manager Kevin Kirby (ACM”)  
County Attorney Joel Foreman  
Clerk of Circuit Court James M. Swisher Jr.  
Deputy Clerk Olga Armas

**Agenda Additions/Deletions**

Additions:

- BA 24-15 FY 2022-2023 Constitutional Officers Financial Report Revision Supervisor of Elections - \$20,102.32
- No Charge Change order – Motorola Solutions
- Authorize County Manager to sign Bethlehem Community Center Contract Documents

Deletions:

- Discussion of Christmas Holiday Policy

MOTION by Commissioner Murphy to approve the agenda. SECOND by Commissioner Hollingsworth. The motion carried unanimously.

**Consent Agenda:**

MOTION by Commissioner Hollingsworth to approve the consent agenda as amended. SECOND by Commissioner Phillips. The motion carried unanimously.

- 1) BCC Administration - BA 24-13 - Funding Additional Veteran Service Officer Position - \$32,308.00
- 2) BCC Administration - Meeting Minutes 08/17/2023
- 3) BCC Administration - Meeting Minutes 10/05/2023
- 4) BCC Administration - Meeting Minutes 10/19/2023
- 5) BCC Administration - Meeting Minutes 11/02/2023
- 6) BCC Administration - Meeting Minutes 11/16/2023
- 7) BCC Administration - Donation of Hazardous Materials Response Trailer
- 8) BCC Administration - Request for Leave - County Manager
- 9) Emergency Management - Adopting the Statewide Mutual Aid Agreement by the County
- 10) Finance - Bills and Vouchers - 11/22/23 - \$3,020,715
- 11) North Florida Economic Development Partnership's ("NFEDP") 2024 Regional Rural Development Grant application
- 12) Public Works - Permission to Enter Private Property for the Purpose of Limb Removal
- 13) Public Works - Permission to Enter Private Property - for the Purpose of Driveway Repair
- 14) Public Works - Utility Permit - AT&T Requesting to Run a line at 5881 NW Lake Jeffery Road
- 15) Public Works - Utility Permit - Hargray of Florida Requesting Permission to Run a Cable at NW Lake City Ave
- 16) Public Works - Utility Permit - Hargray of Florida requesting to run a cable along SW Sisters Welcome Road
- 17) Public Works - Utility Permit - Hargray of Florida Requesting to Run Cable Along the area of NE Buddy Ave and NE Milton

18) Public Works - Utility Permit - AT&T Requesting to Place a Cable on SE County Road 245

19) Zoning Department - SFLP231101

20) Zoning Department - SFLP 231102

21) Zoning Department - SFLP 231005

22) Zoning Department - SFLP 231103

MOTION by Commissioner Hollingsworth to adopt the consent agenda as amended. SECOND by Commissioner Phillips. The motion carried unanimously.

### **Discussion and Action Items**

#### Kevin Kirby, Assistant County Manager

- 1) Change Order for 2023-M - Concrete Foundation Traffic Operations Building

Staff requested approval of Change Order for Project 2023-M Traffic Ops Building due to an increase in the building size. Original Contract building and bidded amount was 150' long. After the contract issuance, the building size is actually 200' long.

MOTION by Commissioner Hollingsworth to approve the change order amount of \$11,540. SECOND by Commissioner Phillips. The motion carried unanimously.

- 2) RFQ 2023-Qv – Solid Waste Engineering Services

Selection of qualified engineers and engineering firms, pursuant to section 287.055 Florida Statutes Consultant Competitive Negotiation Act (“CCNA”), to provide professional engineering services in support of the County Solid Waste Management Program, and also in support of the County Engineer.

MOTION by Commissioner Ford to award Locklear & Associates. SECOND by Commissioner Hollingsworth. The motion carried unanimously. The motion carried unanimously.

MOTION by Commissioner Murphy to send Mr. Frank Darabi a letter of appreciation for the years that he served as an engineer for the County, for

Solid Waste. SECOND by Commissioner Phillips. The motion carried unanimously.

3) Interlocal Agreement - Suwannee River Water Management District-  
Quail Heights Storm water Pond

The Suwannee River Water Management District has agreed to convey property to the County for the County to construct a storm water runoff, flood management pond on property at Quail Heights.

MOTION by Commissioner Murphy to approve Inter-Local Agreement for Quail Heights pond. SECOND by Commissioner Phillips. The motion carried unanimously.

4) Amendment to Agreement for Grant Compliance Services - Hi Dri Storm  
water Improvements

MOTION by Commissioner Ford to approve amendment to agreement for grant compliance. SECOND by Commissioner Hollingsworth. The motion carried unanimously.

5) Amendment to Agreement for Grant Compliance Services - Parnell Hill  
Stormwater Improvements

MOTION by Commissioner Ford to approve amendment to agreement for grant compliance. SECOND by Commissioner Phillips . The motion carried unanimously.

6) BA 24-12 – TDC I-75 Billboard Project

Budget Amendment 24-12 moves funds from TDC reserve to I-75 Billboard Project. The TDC sign was damaged by storms and the repairs will exceed the budget. The County submitted a claim to the insurance carrier. The Amendment will use TDC Fund Reserves to complete the project with all insurance proceeds returned to the reserves when received.

MOTION by Commissioner Hollingsworth to approve BA 24-12 moving \$90,000 from TDC Reserves to the Sign Repair project. SECOND by Commissioner Phillips. The motion carried unanimously.

7) 2023-P I-75 Billboard Project

Staff recommended the Board to award 2023-P to i2 Visual Inc. for the construction and replacement of the TDC/I-75 Billboard and to approve the Agreement.

MOTION by Commissioner Murphy to award bid i2 Visual Inc. for \$169,905.03 and approve contract. SECOND by Commissioner Hollingsworth. The motion carried unanimously.

David Kraus, County Manager

8) Expansion of Designated Urban Development Area

The County has already submitted a request to expand the Designated Urban Development Area (DUDA) in the I-10 corridor region. With the connection of the Ellisville and Fort White water utilities, does the Board wish to consider amending the request to include expanding the County's Designated Urban Development Area in south Columbia County?

Louie Good, County Planner, offered comment.

MOTION by Commissioner Murphy to authorize Staff to work on the DUDA for Ellisville and Fort White. SECOND by Commissioner Phillips. The motion carried unanimously.

9) Lake Jeffery Property Acquisition - \$150,000

The Board previously approved pursuing the acquisition of a lot adjacent to County property on Lake Jeffery Road via a tax sale. The owner paid the taxes and offered the property to the County for \$150,000. The lot appraised for \$192,000. The lot is immediately adjacent to the practice fields/fire station as well as portions of the County properties located on Bascom Norris Road. Staff considers it important to the TDC and Landscaping & Parks long range plans.

MOTION by Commissioner Ford to approve the purchase of parcel 25-3S-16-02284-102 for \$150,000. SECOND by Commissioner Murphy. The motion carried unanimously.

10) Broadband Grant Support Procedure

To create additional steps for Internet Service Providers that wish to receive support from Columbia County in relation to Broadband Infrastructure Grants.

MOTION by Commissioner Murphy to approve procedures for Commissioner's Support of Broadband Grant request. SECOND by Commissioner Phillips. The motion carried unanimously.

11) Third Amendment to Lease for Duval Place - \$441

The Third Amendment to Lease for Duval Place adds additional space for the lease or storage for the Supervisor of Elections. Storage in the TDC/ED hallway will be relocated to this additional space.

MOTION by Commissioner Ford to approve the proposed Third Amendment to the Duval Please Lease. SECOND by Commissioner Phillips. The motion carried unanimously.

12) Buchanan Ingersoll & Rooney - \$96,000

The County wishes to replace one of the lobbyists, Merchant McIntyre, by expanding the contract with Buchanan, Ingersol and Rooney to include federal efforts. The existing vendor did not yield results and Buchanan, Ingersol and Rooney has provided excellent service on the State level. The additional cost is \$500 per month.

MOTION by Commissioner Ford to approve Appendix A to agreement with Buchanan, Ingersol and Rooney. SECOND by Commissioner Hollingsworth. The motion carried unanimously.

13) Lease Agreement with Century Ambulance

Columbia County has an active lease agreement with Century Ambulance for 960-sqft office space and 100 sqft enclosed parking space of Station 49 that has remained unchanged since 2016. New lease agreement to Total Monthly Rent to \$1,200.00 monthly.

MOTION by Commissioner Hollingsworth to approve agreed lease agreement. SECOND by Commissioner Murphy. The motion carried unanimously.

~~14) Discussion of Christmas Holiday Policy~~

15) FY 2022-2023 Constitutional Officer's Annual Financial Reports -  
Property Appraiser - \$75,587

Discussion only

16) FY 2022-2023 Constitutional Officer's Annual Financial Report - Tax  
Collector - \$205,298

Discussion only

17) FY 2022-2023 Constitutional Officer's Annual Financial Reports - Clerk  
of Court

18) BA 24-15 FY 2022-2023 Constitutional Officers Financial Report  
Revision Supervisor of Election - \$20,102.32

The Supervisor of Elections is asking for \$20,102.32 to be returned to her office for the purpose of maintaining the integrity of the voting process for the scheduled elections in FY 2023-2024.

MOTION by Commissioner Murphy to approve BA 24-15. SECOND by Commissioner Ford. The motion carried unanimously.

19) BA 24-14 – FY 2022-2023 Constitutional Officer’s Annual Financial Reports and Reversion – Sheriff’s Office - \$112,956.89

The Sheriff is asking for \$112,956.89 to be returned to purchase Taser equipment.

MOTION by Commissioner Murphy to approve BA 24-14 failed due to a lack of a second.

20) Sheriff’s Office – Budget Amendment #1 Request - \$331,374

The Sheriff has provided additional information and requested the Board to reconsider his Budget Amendment.

MOTION by Commissioner Hollingsworth to approve Sheriff’s Office Budget Amendment #1 - \$331,374. SECOND by Commissioner Phillips. The motion failed 2-3 with Commissioner Ford, Murphy and Williams voting in opposition.

MOTION by Commissioner Ford to take the \$112,000 of funds returned by the Sheriff that was originally requested for Tasers; take \$48,000 from the funds returned by the Tax Collector; plus the Sheriff’s original \$104,000 from BA 24-10 (School Resource Officer Contract), which would total to \$264,000, and use as reoccurring funds for Salaries. SECOND by Commissioner Hollingsworth. The motion carried unanimously.

Nicholas Albrecht offered comment.

21) No Charge Change order – Motorola Solutions

MOTION by Commissioner Ford to approve No Charge Change Order. SECOND by Commissioner Hollingsworth. The motion carried unanimously.

22) Authorize the Chairman and County Manager to sign Bethlehem Community Center Contract



MOTION by Commissioner Ford to authorize the Chairman and County Manager to sign Bethlehem Community Center Contract Phillips. SECOND by Commissioner. The motion carried unanimously.

**Open Public Comments and/or Questions:**

Members of the public offering comment were:

- Nicholas Albrecht
- Stew Lilker

**Staff Comments:**

CM Kraus offered comment on Solid Waste contract with Fort White.

**Commissioner Comments:**

None

**Adjournment**

There being no further business, the meeting adjourned at 10:47 a.m.

ATTEST:

---

Ronald Williams, Chairman  
Board of County Commissioners

---

James M. Swisher, Jr.  
Clerk of Circuit Court



**COLUMBIA COUNTY BOARD OF COUNTY COMMISSIONERS  
AGENDA ITEM REQUEST FORM**

The Board of County Commissioners meets the 1st and 3rd Thursday of each month in the Columbia County School Board Administrative Complex Auditorium, 372 West Duval Street, Lake City, Florida 32055. The first meeting of every month is at 9:30AM while the second meeting of every month takes place at 5:30PM. All agenda items are due in the Board's office one week prior to the meeting date.

Today's Date: 3/6/2024 Meeting Date: 3/21/2024

Department: BCC Administration

**1. Nature and purpose of agenda item:**

Minutes - Regular Meeting - 02/15/2024

**2. Recommended Motion/Action:**

Approve

**3. Fiscal impact on current budget.**

This item has no effect on the current budget.

# Columbia County Board of County Commissioners

February 15<sup>th</sup> 2024 5:30 PM

The Columbia County Board of County Commissioners met in a regularly scheduled meeting in the auditorium of the School Board Administrative Complex. The meeting was called to order by Chairman Williams. Ft White FFA Vice President Trey Tyre gave the invocation. The Pledge of Allegiance to the Flag of the United States led by Columbia County FFA members.

**Commissioners in Attendance:** Chairman, Ronald Williams  
Commissioner, Robby Hollingsworth  
Commissioner, Tim Murphy  
Commissioner, Rocky Ford  
Commissioner, Everett Phillips

**Others in Attendance:** County Manager (CM), David Kraus  
Assistant County Manager (ACM), Kevin Kirby  
County Attorney, Joel Foreman  
Tourism Development Director, Konnie Patke  
Columbia County EMS, Jeff Crawford  
Gallagher Insurance, Tyson Johnson  
Farm Bureau Leadership Academy, Steven Dicks  
County Planner, Louie Goodin  
Deputy Clerk, Amber Taylor

Special presentation of the FFA Creed by member of the Columbia County FFA.

- 1) **Proclamation** No. 2024P-04 declares National FFA Week February 17<sup>th</sup> through February 24<sup>th</sup> in Columbia County, FL. The proclamation was read by Commissioner Murphy (see attached). A flag presentation to the FFA organization ensued.

**Motion** by Commissioner Hollingsworth to accept Proclamation No. 2024P-04 **Seconded** by Commissioner Murphy. Motion carried unanimously.

**Motion** by Commissioner Ford to fly the FFA flag during designated week as stated in the proclamation. **Seconded** by Commissioner Hollingsworth. Motion carried unanimously.

2) **Proclamation** No. 2024P-03 Hazardous Materials Awareness Week February 19<sup>th</sup>- 25<sup>th</sup> 2024

**Motion** by Commissioner Phillips to accept Proclamation No. 2024P-03 in recognition of Hazardous Materials Awareness Week in Columbia County, FL February 19<sup>th</sup> through February 25<sup>th</sup> 2024.

**Seconded** by Commissioner Hollingsworth. Motion carried unanimously.

**Additions or Deletions:**

**Addition**

- 1) Permission for Columbia County to apply for \$50 million dollar Advanced Wastewater System grant. This is a time sensitive issue, due to the deadline of said grant.
  
- 2) Columbia School District requesting for USDA to be granted permission to enter County property at Alligator Lake to enforce wildlife damage management.

**Motion** to approve agenda by Commissioner Hollingsworth. **Seconded** by Commissioner Murphy.

Motion carried unanimously.

**Deletion:**

None.

**Presentation to Board:**

- 1) Mr. George gave presentation on behalf of the Richardson High School Alumni, with the following points of topics:

Priority I Enhance grounds of campus.

Priority II Obtain two classrooms for meetings.

Priority III Secure rooms addressed in II as historical museum.

Priority IV Secure space that you prohibit programs to assist youth throughout community.

Discussion ensued.

Chairman Williams offered response. A meeting between BOCC and the Richardson Alumni Board to be scheduled for further discussion of topics in an effort to be and establish the best ways to move forward with this project.

- 2) Mr. Tyson Johnson gave presentation on the Pro- Share Agreement Refund of \$672,623 with Florida Blue Insurance.

Mr. Kraus requested that the BOCC approve Budget amendment 24-26 to place refund amount of \$672,623 into the insurance account. **Motion** by Commissioner Ford, **Seconded** by Commissioner Hollingsworth. Motion carried unanimously.

### **Public Hearing:**

Commissioner Murphy serves on the Columbia County Resource Board. Therefore he recused himself from conversation or vote on STUP240101

- 1) Mr. Goodin presented special event permit request STUP240101 for the Zambini Family Circus to conduct business on the dates of February 21, 22, and 23<sup>rd</sup> 2024.

**Motion** by Commissioner Ford to approve special event permit STUP240101. **Seconded** by Commissioner Hollingsworth. Motion carried unanimously.

- 2) Attorney Foreman presented Ordinance No. 2024-01 Amending Chapter 62 County Code of Ordinances to remove Corrections Committee in deference to the Public Safety Coordinating Council.

**Motion** to adopt Ordinance No. 2024-01 Amending Chapter 62 of the County Code Ordinances by Commissioner Murphy, **Seconded** by Commissioner Hollingsworth. Motion carried unanimously.

- 3) Attorney Foreman presented Ordinance No. 2024-02 Amending Section 74-82 Relating to Prohibited Residences of Sexual Offenders and Sexual Predators.

**Motion** by Commissioner Ford to adopt Ordinance No. 2024-02, **Seconded** by Commissioner Phillips. Motion carried unanimously.

### **Approval of Consent Agenda:**

**Motion** to approve Consent Agenda by Commissioner Ford, **Seconded** by Commissioner Murphy. Motion carried unanimously.

**Motion** to adopt Consent Agenda by Commissioner Hollingsworth, **Seconded** by Commissioner Murphy. Motion carried unanimously.

**Discussion and Action:**

Joel Foremen, County Attorney

- 1) Attorney Forman put forth a request for a public hearing date to vacate portion of County Road NW Beauchamp Way. Adoption hearing date suggested March 21<sup>st</sup> 2024.

**Motion** by Commissioner Hollingsworth, **Seconded** by Commissioner Phillips, Motion carried unanimously.

Kevin Kirby, Assistant County Manager

- 2) ACM Kirby requested approval of revision of Right-Of-Way Acquisition Guidelines

**Motion** by Commissioner Ford, **Seconded** by Commissioner Hollingsworth. Motion carried unanimously.

- 3) ACM Kirby requested approval to extend existing paving contract for SW Cypress Lake/SW Charles Terrace to include SW Horse Way using current schedule of values.

**Motion** by Commissioner Ford, **Seconded** by Commissioner Hollingsworth, Motion carried unanimously.

- 4) ACM Kirby requested to award bid No. 2023-13 to CA Boone Construction for the repaving of Jordan St in the town of Ft White in the amount of \$353,117.

**Motion** by Commissioner Ford, **Seconded** by Commissioner Phillips. Motion carried unanimously.

- 5) ACM Kirby requested to adopt Supplemental Agreement and resolution 2024R-02 to provide additional funding to SW Jordan Street project in the amount of \$123,154.

**Motion** by Commissioner Ford, **Seconded** by Commissioner Hollingsworth. Motion carried unanimously.

- 6) ACM Kirby requested to approve the created County Inventory Maintenance Map.

**Motion** by Commissioner Ford. **Seconded** by Commissioner Hollingsworth. Motion carried unanimously.

- 7) ACM Kirby requested the approval of the renewal of the following Mowing contracts for the 2024 mowing season: -RFP 2022E Roadside mowing and litter removal  
-2022JJ urban mowing maintenance  
-2022 L retention pond and open area mowing  
-2022M sidewalks and guardrail maintenance

**Motion** by Commissioner Ford, **Seconded** by Commissioner Hollingsworth. Motion carried unanimously.

- 8) ACM Mr. Kirby requested that Columbia County donate 3.74 acres to the FDOT for the construction of community bike trail.

**Motion** by Commissioner Hollingsworth, **Seconded** by commissioner Murphy. Motion carried unanimously.

- 9) ACM Mr. Kirby requested to award bid No. 2023/R BA 24-25 to Gary Johnson Construction in the amount of \$568,149 for the Bethlehem Community Park Improvements.

**Motion** by Commissioner Phillips, **Seconded** by Commissioner Ford. Motion carried unanimously.

- 10) ACM Mr. Kirby requested to award bid No. 2023-12 to Anderson Columbia Construction in the amount of \$4,432,533 for the Ellisville to Ft White water main & to approve the agreement. .

**Motion** by Commissioner Ford, **Seconded** by Commissioner Phillips. Motion carried unanimously.

David Kraus, County Manager

- 11) CM Mr. Krause requested to piggyback on the O'Neal Construction contract in the amount of \$76,449 for the construction of restrooms at the Richardson Community Center.

**Motion** by Commissioner Ford, **Seconded** by Commissioner Murphy. Motion carried unanimously.

- 12) CM Mr. Kraus requested approval of memorandum of agreement with Florida Department of Health for an O2 Generator Trailer.

**Motion** by Commissioner Ford, **Seconded** by Commissioner Murphy. Motion carried unanimously

- 13) CM Mr. Kraus requested starting salary for position of 911 Center Training Coordinator at the rate of \$28.6895 per hour.

**Motion** by Commissioner Ford, **Seconded** by Commissioner Phillips. Motion carried unanimously.

14) CM Mr. Kraus requested that the BOCC reclassify the job description of Financial Officer to reflect the changes in the Fair Labor Act, making said position Administrative Exempt.

**Motion** by Commissioner Hollingsworth, **Seconded** by Commissioner Phillips. Motion carried unanimously.

15) CM Kraus requested that BOCC reclassify the job description of Purchasing Officer to reflect the changes in the fair labor act, making said position Administrative Exempt.

**Motion** by Commissioner Hollingsworth, **Seconded** by Commissioner Phillips. Motion carried unanimously.

16) CM Kraus requested the BOCC appoint Mr. Bill Koon to the Tourist Development Council representing the Town of Ft White & appoint Mr. Ricky Jernigan representing the City of Lake City.

**Motion** by Commissioner Ford, **Seconded** by Commissioner Murphy. Motion carried unanimously.

17) CM Kraus requested BOCC approve the grant agreement for the construction of fire station on Lake Jeffery Rd also referred to as Station # 51.

**Motion** by Commissioner to approve the agreement with the Department of Financial Services for a grant in the amount \$950,000, **Seconded** Commissioner Phillips. Motion carried unanimously.

18) CM Kraus requested BOCC grant consent to apply for a \$53 million dollar grant to be used for the construction of a new sewer plant in Ellisville.

**Motion** by Commissioner Ford, **Seconded** by Commissioner Hollingsworth. Motion carried unanimously.

19) CM Kraus request BOCC to approve an agreement with USDA, granting access to an island within Alligator Park, to address a wildlife issue effecting Columbia High school.

**Motion** by Commissioner Phillips, **Seconded** by Commissioner Hollingsworth. Motion carried unanimously.

**Public Comment:**

Carl King, presented the BOCC with question pertaining to installation of sewer lines alongside the waterlines that are being installed from Ellisville to the Town of Ft. White.

Commissioner Ford offered response.



**Board Comments:**

Commissioner Ford offered his appreciation to his fellow board members, for the support of the installation of the waterline between Ellisville and Ft White.

Commissioner Phillips offered his appreciation to his fellow board members for their support pertaining to growth and development in Ellisville.

Commissioner Murphy recognized and introduction of the newly appointed Tourist Development Director, Konnie Patke.

Chairman Williams made observation of Black History Month with information pertaining to the first African American Florida Highway Patrol officer Mr. (Al) Alfonso Lofton. Mr. Lofton himself, was an alumni to Richardson High School.

**Adjournment:**

There being no further business, the meeting adjourned at 6:28 pm.

---

Ronald Williams, Chairman  
Board of County Commissioners

ATTEST:

---

James M. Swisher, Jr  
Clerk of Circuit Court



## COLUMBIA COUNTY BOARD OF COUNTY COMMISSIONERS AGENDA ITEM REQUEST FORM

The Board of County Commissioners meets the 1st and 3rd Thursday of each month in the Columbia County School Board Administrative Complex Auditorium, 372 West Duval Street, Lake City, Florida 32055. The first meeting of every month is at 9:30AM while the second meeting of every month takes place at 5:30PM. All agenda items are due in the Board's office one week prior to the meeting date.

Today's Date: 3/4/2024 Meeting Date: 3/21/2024

Department: BCC Administration

**1. Nature and purpose of agenda item:**

Release of Lien - Lance Leguire

**2. Recommended Motion/Action:**

Approve the Release of Lien for Lance Leguire

**3. Fiscal impact on current budget.**

This item has no effect on the current budget.



**Suwannee River Economic Council, Inc.**

**Post Office Box 70  
Live Oak, Florida 32064**

**Administrative Office - Phone (386) 362-4115**

**Fax (386) 362-4078**

**E-Mail: [mattpearson@suwanneec.net](mailto:mattpearson@suwanneec.net)**

**Website: [www.srecinc.org](http://www.srecinc.org)**

February 29, 2024

Mr. David Kraus  
Columbia County Manager  
PO Drawer 1529  
Lake City, FL 32056



RE: Columbia County SHIP client Lance Leguire

Dear Mr. Kraus:

Enclosed is check #18757 from Heritage Title Services of North Florida, Inc dated November 6, 2023, made payable to Columbia County SHIP in the amount of \$2,400.00 for the above SHIP client. The original lien in 2015 was for \$12,000. The property is being sold in the ninth year of the SHIP Lien Agreement, and thus only 20% of the lien amount is required to be repaid. A copy of the original SHIP Lien Agreement is enclosed for reference.

If approved by the County's Board of County Commission, please execute and return the enclosed Release of Lien Agreement to SREC, and deposit the enclosed check into the County's SHIP Trust Fund Account for future use.

If you have any questions please call Stephanie Barrington, SHIP Director, at extension 242.

Sincerely,

Matt Pearson, Executive Director  
MP/sb

Enclosure

SREC Finance Department



BRADFORD-COLUMBIA-DIXIE-GILCHRIST-HAMILTON-LAFAYETTE-LEVY-MADISON-PUTNAM-SUWANNEE-TAYLOR-UNION

*"This institution is an equal opportunity provider and employer."  
Funded in part through a grant by the State of Florida Department of Elder Affairs*

This Instrument Prepared By:

Heritage Title Services of N. Florida Inc. ; 201 Parshley Street, SW, Live Oak, FL 32064

RELEASE OF LIEN AGREEMENT UNDER  
STATE HOUSING INITIATIVES PARTNERSHIP PROGRAM

WHEREAS, Lance Robert Leguire (*client name*) executed and delivered to Columbia County, Florida, a political subdivision existing under the laws of the State of Florida, that certain lien agreement under State Housing Initiatives Partnership Program dated January 20th, 2015 and recorded in Official Record Book 1288 Page 114, public records of Columbia County, Florida, granting to Columbia County, Florida, a lien against the following described real property situated in Columbia County, Florida to-wit:

AS DESCRIBED IN SAID LIEN AGREEMENT

WHEREAS, Lance Robert Leguire (*client name*) has paid to Columbia County, Florida, the sum of \$2,400.00 in reimbursement and repayment of funds paid to or for the benefit of Columbia County, FL to assist in the purchase of the above described property.

NOW, THEREFORE, in consideration of the sum of \$2,400.00 and other good and valuable considerations, the receipt whereof are hereby acknowledged, Columbia County, Florida, hereby releases and cancels the lien held against the above described real property by virtue of the afore described lien agreement under State Housing Initiatives Partnership Program.

IN WITNESS WHEREOF, Columbia County, Florida, a political subdivision existing under the laws of the State of Florida, has caused these presents to be executed this \_\_\_\_\_ day of \_\_\_\_\_, 2024.

COLUMBIA COUNTY, FLORIDA

BY: \_\_\_\_\_  
James M. Swisher, Jr., Clerk of Court

STATE OF FLORIDA  
COUNTY OF COLUMBIA

The foregoing release and satisfaction of lien agreement under State of Florida Housing Initiatives Partnership Program was acknowledged before methis \_\_\_\_\_ day of \_\_\_\_\_, 2024, by James M. Swisher, Jr., Clerk of Court, Columbia County, FL, who is personally known to me.

\_\_\_\_\_  
Notary Public

(NOTARIAL SEAL)

LIEN AGREEMENT UNDER STATE OF FLORIDA  
HOUSING INITIATIVES PARTNERSHIP PROGRAM

THIS INDENTURE, made this 22<sup>nd</sup> day of JANUARY, 2015, between LANCE ROBERT LEGUIRE,  
AN UNMARRIED MAN

Whose residence address is 500 SE TRIBBLE STREET, LAKE CITY, FLORIDA 32025  
And whose mailing address is 500 SE TRIBBLE STREET, LAKE CITY, FLORIDA 32025  
And whose Social Security number is N/A  
Hereinafter called the "Owner" ("Owner" refers to singular or plural as the context requires), and  
COLUMBIA COUNTY, FLORIDA, A POLITICAL SUBDIVISION EXISTING UNDER THE LAWS  
OF THE State of Florida (Federal ID No. \_\_\_\_\_), whose post office address is c/o Clerk of  
the Circuit Court, P.O. Box 2069, Lake City, Florida 32056, hereinafter called "County";  
WITNESSETH:

WHEREAS, the State of Florida through County has made available to Owner under the  
State Housing Initiatives Partnership Program, Chapter 420, part VIII, Florida Statutes, and  
Columbia County Ordinance No. 93-4, hereinafter referred to jointly as "SHIP", funds to be used in  
the purchase of newly constructed or rehabilitation of housing for families and individuals of low and  
moderate income; and

WHEREAS, the funds may not be used to produce windfall profits to Owner from the sale,  
rental, gift or improper use of properties assisted with such funds.

NOW, that for good, valuable, and adequate consideration, and also in consideration of the  
aggregate sum named in the promissory note hereinafter described, the Mortgagee does hereby  
confirm, alien, mortgage, pledge, encumber, collateral assign and grant a lien and security interest  
to and in favor of the Mortgagee, the property of which the Mortgagee is now seized and possessed and  
in actual possession, situate in Columbia County, State of Florida, (hereinafter referred to as the  
"property" or the "premises" or the "Mortgaged premises"), described as follows, to wit:

Lot 13, Block D, BELLAIRE SUBDIVISION, a Subdivision according to the Plat thereof as recorded  
in Plat Book 3, Page 66 of the Public Records of Columbia County, Florida.

Together with all and singular the tenements, hereditaments and appurtenances thereto  
belonging, hereinafter referred to as "Property", and the said Owner does hereby fully warrant the  
title to said Property and will defend the same against the lawful claims of all persons whomsoever.

Owner hereby acknowledges covenants and agrees to and with County as follows:

1. SHIP funds in the amount of Twelve Thousand Dollars and 00/100  
(\$12,000.00) have been provided to or for the benefit of the Owner to assist in the  
purchase/rehabilitation of the Property, the receipt whereof is hereby acknowledged by the Owner.  
The funds are provided as a ten (10) year non-interest bearing loan to be forgiven subject to the  
provisions of this agreement.
2. Owner shall occupy the Property as Owner's principal residence for a  
minimum period of ten (10) years from the date of this instrument.
3. If, within the period of ten (10) years immediately following the date of this  
instrument, the property shall be sold, transferred or otherwise disposed of or if the Owner shall die,  
Owner, Owner's estate or the person or persons acquiring any title or interest in the Property shall  
pay to the County that percent of said financial assistance provided to Owner under the SHIP  
program to be determined as follows:

Doc 201512001091 Date 1/21/2015 Time 4:36 PM  
Doc 201512001091 Date 1/21/2015 Time 4:36 PM  
Doc P. DeWitt Cason, Columbia County Page 1 of 3 B: 1288 P: 114

**IF PROPERTY IS SOLD, TRANSFERRED  
OR OTHERWISE DISPOSED OF OR IF  
OWNER SHOULD DIE AT ANYTIME  
DURING THE:**

**PERCENT OF FINANCIAL ASSISTANCE  
TO BE REPAYED TO COUNTY:**

First year	100 Percent
Second year	90 Percent
Third year	80 Percent
Fourth year	70 Percent
Fifth year	60 Percent
Sixth year	50 Percent
Seventh year	40 Percent
Eighth year	30 Percent
Ninth year	20 Percent
Tenth year	10 Percent
After 10 years	0 Percent

*Transfer means any conveyance of the Property or any interest therein, voluntary or involuntary, transfer by reason of death of Owner, or delivery of possession of the Property for occupancy by one other than the Owner whether by oral agreement or contract for deed, lease, rental agreement or otherwise; provided, however, if illness of the Owner should make it impossible for the Owner to reside on or care for the property, then the Owner may rent or lease the Property, but only with written consent of and upon the terms and conditions imposed by the SHIP Loan Committee.*

*The County may forgive any of the SHIP assistance should there be insufficient net proceeds derived from a good faith sale of the Property at market value during the ten (10) year period following the date of this agreement upon approval of the SHIP Loan Committee. "Net proceeds" is defined as the amount remaining after all private debt is repaid.*

- Paragraph 3 of this agreement regarding transfer of the subject Property shall not apply to a transfer from the Owner to the Owner's spouse; but if transferred to an Owner's spouse, the agreements contained herein shall run with title to the land and, thereafter, be applicable to any transfer made by the transferee's spouse; the time period for reimbursement to the County as set forth herein shall be computed from the date of this agreement.*
- The Owner shall promptly pay all taxes, assessments and encumbrances of every nature now on the property or that hereafter may be imposed when due and payable according to law and before they shall become delinquent.*
- To place and continuously keep the improvements on the Property insured against loss or damage by fire and other hazards included within the term "extended coverage" in the usual standard policy form in a sum not less than full insurable value and County shall be named in the policy as a loss payee as its interest may appear.*
- To maintain the Property in good condition and not permit or suffer any waste, impairment or deterioration of said Property.*
- If the Owner shall become in default under any provision in this lien agreement for a period of thirty (30) days, then, at the option of County, Owner shall immediately pay to County, without demand, the same amount that Owner would become obligated to pay to County upon sale or conveyance of the Property to be determined in accordance with the provisions of paragraph 3 hereof. Upon default the amount payable shall immediately become due and payable and interest shall accrue thereon at the rate of twelve percent (12%) per annum until both the principal and interest shall be paid in full.*
- If this lien agreement is made subject to a prior lien on the Property, then Owner covenants and agrees that Owner will not make any future advances under said prior lien without the written consent of the SHIP Loan Committee.*

- 10. If the Owner should become in default in the performance of this lien agreement, Owner agrees to pay all cost, including reasonable attorney's fees, whether suit be brought or not, if counsel be employed to collect this obligation or to protect the security thereof, including all costs and attorney's fees incurred on appeal. The amount of accrued interest, court costs and attorney's fees payable to County shall be determined by a court of competent jurisdiction, and not by jury, and shall be taxed as costs to be paid by the Owner.
- 11. This instrument shall be recorded in the office of the Clerk of the Circuit Court in the County where the Property is located and shall be a lien upon Owner's Property described hereinabove. This agreement shall be binding upon the heirs, devisees, successors and assigns of the Owner.
- 12. If this agreement shall not be released by written instrument of County at an earlier date, this agreement shall automatically expire ten (10) years from date hereof and no further claim shall be made hereunder.

IN WITNESS WHEREOF, Owner has executed this instrument under seal on the day and year first above written.

Signed, sealed and delivered  
In the presence of:

*[Signature]*  
WITNESS

*[Signature]* (SEAL)  
LANCE ROBERT LEGUIRE.

*[Signature]*  
WITNESS

*[Signature]*  
WITNESS

*[Signature]*  
WITNESS

\_\_\_\_\_ (SEAL)

STATE OF FLORIDA  
COUNTY OF COLUMBIA

The foregoing Lien Agreement was acknowledged before me this 20<sup>th</sup> day of JANUARY 2015, by LANCE ROBERT LEGUIRE..

Who ~~is~~ personally known to me or  who has produced \_\_\_\_\_ as identification

Driver's License  
(NOTARIAL SEAL)

*[Signature]*  
Notary Public

**Brenda Styons**

Print or type Notary Public's Name

My Commission Expires: \_\_\_\_\_



BRENDA STYONS  
MY COMMISSION # EE 168731  
EXPIRES: February 6, 2018  
Bonded Thru Budget Notary Services



**COLUMBIA COUNTY BOARD OF COUNTY COMMISSIONERS  
AGENDA ITEM REQUEST FORM**

The Board of County Commissioners meets the 1st and 3rd Thursday of each month in the Columbia County School Board Administrative Complex Auditorium, 372 West Duval Street, Lake City, Florida 32055. The first meeting of every month is at 9:30AM while the second meeting of every month takes place at 5:30PM. All agenda items are due in the Board's office one week prior to the meeting date.

**Today's Date:** 3/14/2024 **Meeting Date:** 3/21/2024

**Department:** BCC Administration

**1. Nature and purpose of agenda item:**

BA 24-31 - Funds for Grant Administration were budgeted in FY 2022-2023. Due to retainage and grant closeout issues, not all funds were paid out before October 1, 2023. The grant is now being closed out. This Budget Amendment moves \$7,125 from year end funds to pay the final grant administration costs for the Ellisville Wastewater Treatment Plant.

**2. Recommended Motion/Action:**

Approve BA 24-31

**3. Fiscal impact on current budget.**

This item is not budgeted. The proposed budget amendment to fund this request is provided below.

The budget amendment number is BA 24-31 using fund(s) 001-GENERAL FUND and 405-UTILITIES FUND.

FROM:	TO:	AMOUNT:
001-8400-584.90-98 RESERVES/CASH BALANCE FORWARD	001-8100-581.91-45 INTERFUND TRANSFERS OUT/TO UTILITIES FUND	\$7,125.00
405-0000-381.10-20 INTERFUND TRANSFERS IN/TRSF FROM GENERAL FUND	405-3505-535.60-31 CAPITAL OUTLAY/PROF SERVICES-CAPITALIZED	\$7,125.00





**COLUMBIA COUNTY BOARD OF COUNTY COMMISSIONERS  
AGENDA ITEM REQUEST FORM**

The Board of County Commissioners meets the 1st and 3rd Thursday of each month in the Columbia County School Board Administrative Complex Auditorium, 372 West Duval Street, Lake City, Florida 32055. The first meeting of every month is at 9:30AM while the second meeting of every month takes place at 5:30PM. All agenda items are due in the Board's office one week prior to the meeting date.

Today's Date: 3/13/2024 Meeting Date: 3/21/2024

Department: Finance

**1. Nature and purpose of agenda item:**

This item requests Board approval for the payment of bills and vouchers in the amount of \$3,759,194.74 submitted 3/13/24. All funds authorized for the issuance of these checks have been budgeted. The Clerk to the Board office reviews bills and vouchers submitted for approval. If for any reason, any of these bills are not recommended for approval, the Clerk to Board office will notify the Board. The Clerk to the Board office maintains copies of invoices and supporting documentation for review.

**2. Recommended Motion/Action:**

Approve payment of bills and vouchers in the amount of \$3,759,194.74

**3. Fiscal impact on current budget.**

This item has no effect on the current budget.

# COLUMBIA COUNTY BOARD OF COMMISSIONERS ACCOUNTS PAYABLE CHECK REGISTER

<b>Check Date</b>	<b>Beginning Check Number</b>	<b>Ending Check Number</b>	<b>Number of Checks</b>	<b>Positive Pay File Upload Date</b>	<b>Check Register Total</b>
3/13/2024	51584	51759	176	3/13/2024	\$3,759,194.74
	<b>TOTAL CHECKS &amp; AMOUNT</b>		<b>176</b>		<b>\$3,759,194.74</b>

PROGRAM GM344LR  
COLUMBIA COUNTY  
BANK 00

CHECK NO	VENDOR NO	VENDOR NAME	VOUCHER NO	P.O. NO	DATE	VOUCHER AMOUNT	REMITTANCE AMOUNT	CHECK TOTAL
0051584	0002013	A T & T	001658		3/13/2024	340.41		
			001705		3/13/2024	3,015.00		
			001712		3/13/2024	1,773.24		
			4155	P45962	3/13/2024	26.61		
			001799		3/13/2024	190.00		
			001800		3/13/2024	190.00		
			001801		3/13/2024	190.00	5,725.26	5,725.26
0051585	0001207	ADVANCE AUTO PARTS	3987	P45867	3/13/2024	72.31		
			3988	P45868	3/13/2024	67.51		
			3996	P45788	3/13/2024	67.81		
			4018	P45834	3/13/2024	51.55		
			4161	P46043	3/13/2024	148.89		
			4165	P45989	3/13/2024	297.78		
			4166	P45990	3/13/2024	342.15	1,048.00	1,048.00
0051586	0001547	ADVANCED ENVIRONMENTAL	LA3972	P45870	3/13/2024	84.90		
			3973	P45871	3/13/2024	127.35	212.25	212.25
0051587	0004792	AG-PRO LAKE CITY	4006	P45816	3/13/2024	399.85	399.85	399.85
0051588	0000111	ANDERSON COLUMBIA CO., IN	4131	P46030	3/13/2024	464.20		
			4140	P46013	3/13/2024	446.60	910.80	910.80
0051589	0006060	ANN C. HODGES	4257	P46158	3/13/2024	1,000.00	1,000.00	1,000.00
0051590	0003440	APPLIED CONCEPTS, INC.	PI4174	027259	3/13/2024	112.50		
			PI4175	027259	3/13/2024	11,750.00	11,862.50	11,862.50
0051591	0000218	BAKER & TAYLOR BOOKS	PI4103	027080	3/13/2024	288.45		
			PI4104	027081	3/13/2024	531.02		
			PI4105	027082	3/13/2024	247.75		
			PI4108	027089	3/13/2024	1,168.25	2,235.47	2,235.47
0051592	0000251	BAKER DISTRIBUTING CO.	3921	P43206	3/13/2024	12.29	12.29	12.29
0051593	0005251	BATTERIES PLUS	4009	P45819	3/13/2024	79.50	79.50	79.50
0051594	0003643	BEARD EQUIPMENT CO. INC.	3922	P45841	3/13/2024	3.72		
			3923	P45841	3/13/2024	26.58		
			3924	P45841	3/13/2024	36.15		
			4062	P46034	3/13/2024	427.34		
			4063	P46034	3/13/2024	51.47		
			4064	P46034	3/13/2024	29.18		
			4072	P46042	3/13/2024	29.40		
			4073	P46042	3/13/2024	70.26		
			4074	P46042	3/13/2024	25.04		
			4130	P45675	3/13/2024	993.75	1,692.89	1,692.89
0051595	0004746	BEAVER BULK, INC.	PI3909	027196	3/13/2024	4,799.76		
			PI4112	027196	3/13/2024	965.75		
			PI4113	027244	3/13/2024	3,060.53	8,826.04	8,826.04
0051596	0005085	BIBLIOTHECA, LLC	4167	P45994	3/13/2024	780.00		
			4168	P45995	3/13/2024	447.97	1,227.97	1,227.97
0051597	0000262	BIELLINGS TIRE	3949	P45842	3/13/2024	161.00	161.00	161.00
0051598	0004680	BLUE SUMMIT WATERS, LLC	001632		3/13/2024	7.95		
			001633		3/13/2024	7.95		
			001634		3/13/2024	15.95		
			001635		3/13/2024	9.95		
			001636		3/13/2024	11.00		
			001637		3/13/2024	25.15		
			001638		3/13/2024	33.10		
			001639		3/13/2024	35.05		

PROGRAM GM344LR  
COLUMBIA COUNTY  
BANK 00

CHECK NO	VENDOR NO	VENDOR NAME	VOUCHER NO	P.O. NO	DATE	VOUCHER AMOUNT	REMITTANCE AMOUNT	CHECK TOTAL
0051598	0004680	BLUE SUMMIT WATERS, LLC	001640		3/13/2024	35.05		
			001641		3/13/2024	6.00		
			001642		3/13/2024	39.10		
			001643		3/13/2024	33.10		
			001643		3/13/2024	35.05		
			001643		3/13/2024	27.10		
			001643		3/13/2024	19.15		
			001643		3/13/2024	26.20		
			001643		3/13/2024	25.15		
			001643		3/13/2024	41.05		
			001643		3/13/2024	6.00		
			001643		3/13/2024	33.10		
			001643		3/13/2024	41.05		
			001643		3/13/2024	67.70		
			001643		3/13/2024	51.65		
			001643		3/13/2024	22.90		
			001643		3/13/2024	41.75		
			001643		3/13/2024	43.70		
			001643		3/13/2024	17.95		
			001643		3/13/2024	9.95		
			001643		3/13/2024	35.80	804.60	804.60
0051599	0000235	BLUE-GREY ARMY, INC.	PI4114	027191	3/13/2024	9,957.00	9,957.00	9,957.00
0051600	0003914	BRENT HAYDEN, M.D. P.A.	001790		3/13/2024	90.00		
			001791		3/13/2024	90.00		
			001792		3/13/2024	200.00		
			001793		3/13/2024	270.00	650.00	650.00
0051601	0003201	CALVIN THOMAS FARMS	3966	P44556	3/13/2024	57.50	57.50	57.50
0051602	0002978	CITY OF JACKSONVILLE	001645		3/13/2024	43,875.00	43,875.00	43,875.00
0051603	0000304	CITY OF LAKE CITY - UTILI	001669		3/13/2024	540.67		
			001670		3/13/2024	535.45		
			001802		3/13/2024	279.60		
			001803		3/13/2024	210.18		
			001804		3/13/2024	225.74		
			001805		3/13/2024	75.24		
			001806		3/13/2024	12,598.27		
			001807		3/13/2024	785.23		
			001808		3/13/2024	180.82		
			001809		3/13/2024	203.02		
			001810		3/13/2024	28.12		
			001811		3/13/2024	77.70	15,740.04	15,740.04
0051604	0002636	CITY OF LIVE OAK	4244	P46145	3/13/2024	185.06		
			4245	P46146	3/13/2024	184.96	370.02	370.02
0051605	0004421	CITY OF PERRY	4246	P46147	3/13/2024	77.28	77.28	77.28
0051606	0006277	CLARK, ASHELY MICHELLE	4158	P45974	3/13/2024	135.00	135.00	135.00
0051607	0000308	CLAY ELECTRIC COOPERATIVE	4247	P46148	3/13/2024	127.36	127.36	127.36
0051608	0006034	COACT ASSOCIATES, LTD.	PI4118	027318	3/13/2024	5,250.00		
			PI4119	027318	3/13/2024	5,250.00		
			PI4120	027318	3/13/2024	5,250.00		
			PI4121	027318	3/13/2024	5,250.00		
			PI4122	027318	3/13/2024	5,250.00	26,250.00	26,250.00
0051609	0000321	COLUMBIA COUNTY HEALTH DE	001646		3/13/2024	16,019.17		
			001647		3/13/2024	16,019.17	32,038.34	32,038.34

PROGRAM GM344LR  
COLUMBIA COUNTY  
BANK 00

CHECK NO	VENDOR NO	VENDOR NAME	VOUCHER NO	P.O. NO	DATE	VOUCHER AMOUNT	REMITTANCE AMOUNT	CHECK TOTAL
0051610	0008191	COLUMBIA COUNTY SCHOOL BO	0001794		3/13/2024	1,198.54	1,198.54	1,198.54
0051611	0002039	SHERIFF COLUMBIA COUNTY	001814		3/13/2024	1,706,575.00	1,706,575.00	1,706,575.00
0051612	0003042	COLUMBIA COUNTY TAX COLLE	001679		3/13/2024	30,604.00	30,604.00	30,604.00
0051613	0004021	COLUMBIA COUNTY UTILITY S	001659		3/13/2024	43.63		
			001660		3/13/2024	137.77		
			001661		3/13/2024	89.83		
			001662		3/13/2024	43.63		
			001663		3/13/2024	49.42		
			001664		3/13/2024	49.42	413.70	413.70
0051614	0002822	COMCAST	4088	P46058	3/13/2024	148.35		
			4089	P46059	3/13/2024	182.99		
			4204	P46092	3/13/2024	106.85		
			4250	P46151	3/13/2024	199.19		
			4251	P46152	3/13/2024	164.90	802.28	802.28
0051615	0002822	COMCAST,GRP-1	001665		3/13/2024	339.96	339.96	339.96
0051616	0002822	COMCAST,GRP-2	001666		3/13/2024	43.00	43.00	43.00
0051617	0002822	COMCAST,GRP-3	001671		3/13/2024	549.57	549.57	549.57
0051618	0002822	COMCAST,GRP-4	4058	P46054	3/13/2024	104.00	104.00	104.00
0051619	0002822	COMCAST,GRP-5	001812		3/13/2024	119.85	119.85	119.85
0051620	0002822	COMCAST,GRP-6	001813		3/13/2024	272.66	272.66	272.66
0051621	0002822	COMCAST,GRP-7	001813		3/13/2024	333.79	333.79	333.79
0051622	0000353	COMCAST BUSINESS	001179		3/13/2024	3,021.45		
			001180		3/13/2024	2,172.63		
			001181		3/13/2024	246.55		
			001182		3/13/2024	469.83		
			001183		3/13/2024	207.13		
			001184		3/13/2024	1,759.93		
			001185		3/13/2024	339.06		
			001186		3/13/2024	715.79		
			001187		3/13/2024	715.79		
			001188		3/13/2024	1,062.59		
			001189		3/13/2024	246.55		
			001190		3/13/2024	246.55		
			4154	P45960	3/13/2024	327.80	11,531.65	11,531.65
0051623	0003903	COMPSYCH	000778		3/13/2024	127.60		
			000779		3/13/2024	7.98		
			000780		3/13/2024	31.90		
			000781		3/13/2024	143.57		
			000782		3/13/2024	7.98		
			000783		3/13/2024	3.23		
			000784		3/13/2024	7.98		
			000785		3/13/2024	334.99		
			000786		3/13/2024	15.95		
			000788		3/13/2024	23.93		
			000789		3/13/2024	127.60		
			000790		3/13/2024	7.98		
			000791		3/13/2024	7.98		
			000792		3/13/2024	143.57		
			000793		3/13/2024	79.76		
			000794		3/13/2024	71.78		
			000795		3/13/2024	39.88		
			000796		3/13/2024	79.76		

CHECK NO	VENDOR NO	VENDOR NAME	VOUCHER NO	P.O. NO	DATE	VOUCHER AMOUNT	REMITTANCE AMOUNT	CHECK TOTAL
0051623	0003903	COMPSYCH	000797		3/13/2024	7.98		
			000798		3/13/2024	79.76		
			000799		3/13/2024	135.59		
			000800		3/13/2024	95.70		
			000801		3/13/2024	467.35		
			000802		3/13/2024	95.70		
			000803		3/13/2024	31.90		
			000804		3/13/2024	23.93		
			000805		3/13/2024	7.98		
			000806		3/13/2024	23.93		
			000807		3/13/2024	103.54		
			000808		3/13/2024	23.93		
			000809		3/13/2024	7.98		
			000810		3/13/2024	23.93		
			000811		3/13/2024	127.61		
			000812		3/13/2024	10.63		
			000507		3/13/2024	10.63		
			000571		3/13/2024	10.63		
			000571		3/13/2024	39.88	2,592.00	2,592.00
0051624	0005176	CORE & MAIN LP	PI4034	027311	3/13/2024	6,170.00		
			PI4035	027311	3/13/2024	8,734.00	14,904.00	14,904.00
0051625	0003614	CO2 DIRECT GAS, INC.	4098	P46061	3/13/2024	22.00	22.00	22.00
0051626	0004846	CREATIVE CONCRETE DESIGN	PI3962	027123	3/13/2024	1,125.00	1,125.00	1,125.00
0051627	0002417	CRYSTAL SPRINGS	4262	P46163	3/13/2024	88.49	88.49	88.49
0051628	0005358	CUMMINS SALES & SERVICE	4223	P45797	3/13/2024	1,893.71	1,893.71	1,893.71
0051629	0000440	DELL MARKETING L.P.	4005	P45814	3/13/2024	217.34		
			4243	P46111	3/13/2024	2,212.53		
			4263	P46164	3/13/2024	425.48	2,855.35	2,855.35
0051630	0000615	DUKE ENERGY	001666		3/13/2024	32.02		
			001666		3/13/2024	32.02		
			001666		3/13/2024	30.79		
			001667		3/13/2024	30.79		
			4248	P46149	3/13/2024	147.34		
			4249	P46150	3/13/2024	192.74	465.70	465.70
0051631	0006174	ENTERPRISE FM TRUST	001045		3/13/2024	502.25		
			001046		3/13/2024	137.67		
			001047		3/13/2024	120.95		
			001047		3/13/2024	2,615.24		
			001047		3/13/2024	807.48		
			001047		3/13/2024	773.52		
			001047		3/13/2024	388.11		
			001047		3/13/2024	107.82		
			001047		3/13/2024	107.33		
			001047		3/13/2024	1,731.10		
			001047		3/13/2024	490.37		
			001047		3/13/2024	345.77		
			001047		3/13/2024	2,019.98		
			001047		3/13/2024	655.11		
			001047		3/13/2024	525.41		
			001047		3/13/2024	1,602.46		
			001047		3/13/2024	475.90		
			001047		3/13/2024	493.89		

CHECK NO	VENDOR NO	VENDOR NAME	VOUCHER NO	P.O. NO	DATE	VOUCHER AMOUNT	REMITTANCE AMOUNT	CHECK TOTAL
0051631	0006174	ENTERPRISE FM TRUST	001047		3/13/2024	2,298.05		
			001047		3/13/2024	681.91		
			001047		3/13/2024	493.49		
			001047		3/13/2024	14,257.15		
			001047		3/13/2024	4,435.37		
			001047		3/13/2024	3,209.28		
			001047		3/13/2024	1,052.34		
			001047		3/13/2024	323.62		
			001047		3/13/2024	225.30		
			001047		3/13/2024	564.61		
			001047		3/13/2024	170.23		
			001047		3/13/2024	103.56		
			001047		3/13/2024	571.96		
			001047		3/13/2024	180.62		
			001047		3/13/2024	289.84		
			001300		3/13/2024	2,104.68		
			001300		3/13/2024	644.05		
			001300		3/13/2024	450.60	45,377.34	45,377.34
0051632	0000534	EVACHEK'S TREE SERVICE	3970	P45873	3/13/2024	65.00	65.00	65.00
0051633	0002990	FEDEX	3932	P45885	3/13/2024	37.12	37.12	37.12
0051634	0006071	FERREIRA FUNERAL SERVICES	001677		3/13/2024	450.00	450.00	450.00
0051635	0006235	FLETCHER & SIPPEL LLC	4171	P46080	3/13/2024	1,439.00	1,439.00	1,439.00
0051636	0006278	FLORIDA COUNTRY PUBLICATI	4153	P45959	3/13/2024	900.00	900.00	900.00
0051637	0003426	FLORIDA ECONOMIC DEVELOPM	4127	P45440	3/13/2024	425.00	425.00	425.00
0051638	0000642	FLORIDA PEST CONTROL	3967	P45742	3/13/2024	13.44		
			4003	P45923	3/13/2024	25.00		
			4036	P45743	3/13/2024	33.00		
			4125	P45938	3/13/2024	31.00		
			4126	P45939	3/13/2024	31.00		
			4144	P46051	3/13/2024	21.00		
			4156	P45964	3/13/2024	35.00		
			4193	P46142	3/13/2024	32.00		
			4239	P46093	3/13/2024	33.00	254.44	254.44
0051639	0004154	FORT WHITE TRUE VALUE HAR	4226	P46098	3/13/2024	9.98		
			4227	P46099	3/13/2024	23.98	33.96	33.96
0051640	0004689	FORTILINE, INC.	3968	P45869	3/13/2024	242.19	242.19	242.19
0051641	0000690	FOURAKER ELECT., INC.	4123	P46002	3/13/2024	83.89		
			4124	P46003	3/13/2024	127.40	211.29	211.29
0051642	0000348	FURST-MCNESS COMPANY	3995	P45770	3/13/2024	199.90	199.90	199.90
0051643	0000806	G.W. HUNTER, INC.	4021	P45863	3/13/2024	262.90		
			4043	P45950	3/13/2024	679.76		
			4138	P45937	3/13/2024	35.52		
			4141	P46015	3/13/2024	565.92		
			4142	P46015	3/13/2024	469.00		
			4143	P46015	3/13/2024	97.07		
			4145	P46055	3/13/2024	145.23		
			4162	P45979	3/13/2024	56.37		
			4172	P46088	3/13/2024	400.00		
			PI4173	027124	3/13/2024	25,282.26		
			PI4176	027132	3/13/2024	9,372.07		
			4197	P46074	3/13/2024	183.44	37,549.54	37,549.54
0051644	0001860	GALE/CENGAGE LEARNING	3978	P45824	3/13/2024	474.95		

CHECK NO	VENDOR NO	VENDOR NAME	VOUCHER NO	P.O. NO	DATE	VOUCHER AMOUNT	REMITTANCE AMOUNT	CHECK TOTAL
0051644	0001860	GALE/CENGAGE LEARNING	3981	P45823	3/13/2024	64.97		
			3997	P45897	3/13/2024	20.14	560.06	560.06
0051645	0000702	GALLS, LLC	3929	P45886	3/13/2024	193.04		
			4184	P46100	3/13/2024	236.80		
			4186	P46101	3/13/2024	129.68	559.52	559.52
0051646	0000759	GATEWAY-FOREST LAWN FUNER	001648		3/13/2024	450.00	450.00	450.00
0051647	0000762	GENESIS DOOR & HARDWARE,	4139	P46005	3/13/2024	300.00	300.00	300.00
0051648	0000754	GRAHAM & SONS ELECTRICAL,	4070	P46041	3/13/2024	1,200.00		
			4071	P46041	3/13/2024	1,288.00		
			4094	P46057	3/13/2024	900.00		
			4095	P46057	3/13/2024	675.00		
			4096	P46057	3/13/2024	325.00		
			4097	P46057	3/13/2024	450.00	4,838.00	4,838.00
0051649	0000724	GRAINGER	4152	P46009	3/13/2024	123.12	123.12	123.12
0051650	0000745	GREAT AMERICA FINANCIAL S	4258	P46159	3/13/2024	451.60		
			4259	P46160	3/13/2024	300.89	752.49	752.49
0051651	0000794	GREEN'S MARINE & SPORTING	4101	P46060	3/13/2024	66.52		
			4136	P45865	3/13/2024	100.80	167.32	167.32
0051652	0004163	GREYSON TECHNOLOGIES	4232	P46071	3/13/2024	820.00	820.00	820.00
0051653	0000743	GUERRY FUNERAL HOME	001677		3/13/2024	450.00		
			001677		3/13/2024	450.00		
			001677		3/13/2024	450.00	1,350.00	1,350.00
0051654	0004804	HAWKINS, INC.	4159	P46016	3/13/2024	429.00		
			4160	P46017	3/13/2024	317.70	746.70	746.70
0051655	0000818	HILL MANUFACTURING CO., I	4015	P45793	3/13/2024	488.00	488.00	488.00
0051656	0002718	HOME DEPOT PRO	4013	P45921	3/13/2024	136.71	136.71	136.71
0051657	0005427	HONEYWELL ANALYTICS, INC	4231	P45829	3/13/2024	1,155.00	1,155.00	1,155.00
0051658	0000835	H2 REHABILITATION SERV.OF	001680		3/13/2024	70.00		
			001681		3/13/2024	35.00		
			001682		3/13/2024	70.00		
			001683		3/13/2024	105.00	280.00	280.00
0051659	0000952	ICS CREMATION AND FUNERAL	001706		3/13/2024	450.00		
			001707		3/13/2024	450.00	900.00	900.00
0051660	0005367	IMMAC POWER SOLUTIONS INC	PI3908	027075	3/13/2024	500.00		
			PI4051	027075	3/13/2024	500.00	1,000.00	1,000.00
0051661	0000904	INGRAM BOOK COMPANY	3974	P45915	3/13/2024	63.97	63.97	63.97
0051662	0000911	INTERSTATE SUPPLY	3938	P45840	3/13/2024	30.43		
			3976	P45918	3/13/2024	217.22		
			4025	P45919	3/13/2024	2.64	250.29	250.29
0051663	0006263	I2 VISUAL, INC	PI4054	027240	3/13/2024	79,325.00	79,325.00	79,325.00
0051664	0006226	J & J GAS SERVICE, INC	3925	P45893	3/13/2024	188.99		
			3926	P45895	3/13/2024	319.48		
			3927	P45894	3/13/2024	79.95		
			4083	P45912	3/13/2024	85.00		
			4084	P45911	3/13/2024	769.26		
			4085	P45909	3/13/2024	489.13	1,931.81	1,931.81
0051665	0005967	JAMES E. CLAYTON	4007	P45818	3/13/2024	935.00		
			4008	P45818	3/13/2024	805.00	1,740.00	1,740.00
0051666	0000310	JAMES M. SWISHER, JR.	001650		3/13/2024	47,687.00	47,687.00	47,687.00
0051667	0001025	JSC SYSTEMS, INC.	3931	P45852	3/13/2024	885.00		
			3947	P45874	3/13/2024	1,582.00	2,467.00	2,467.00
0051668	0004322	KAIL PARTNERS, LLC	PI3596	027198	3/13/2024	38,500.00	38,500.00	38,500.00



PROGRAM GM344LR  
COLUMBIA COUNTY  
BANK 00

CHECK NO	VENDOR NO	VENDOR NAME	VOUCHER NO	P.O. NO	DATE	VOUCHER AMOUNT	REMITTANCE AMOUNT	CHECK TOTAL
0051669	0001968	KIMI ROBERTS	001814		3/13/2024	8.46		
			001814		3/13/2024	8.28	16.74	16.74
0051670	0006109	KNIGHT N DAY SALES LLC	4151	P45976	3/13/2024	750.24	750.24	750.24
0051671	0006126	KNIGHT TECHNOLOGY GROUP	3902	P45807	3/13/2024	359.61		
			PI3904	027291	3/13/2024	2,790.80		
			3989	P45872	3/13/2024	29.19	3,179.60	3,179.60
0051672	0004773	KNOX COMPANY	3936	P45881	3/13/2024	274.00	274.00	274.00
0051673	0001231	LAKE CITY ADVERTISER	4011	P45899	3/13/2024	500.00		
			4045	P45952	3/13/2024	500.00		
			PI4115	027202	3/13/2024	1,000.00		
			4163	P45980	3/13/2024	246.54		
			4164	P45982	3/13/2024	282.36	2,528.90	2,528.90
0051674	0001212	LAKE CITY AUTO PARTS	3990	P45751	3/13/2024	104.08		
			3999	P45801	3/13/2024	13.62		
			4017	P45833	3/13/2024	69.16		
			4050	P45946	3/13/2024	10.54		
			4137	P45887	3/13/2024	19.98		
			4146	P45879	3/13/2024	16.92		
			4148	P45933	3/13/2024	201.18		
			4150	P45953	3/13/2024	34.24	469.72	469.72
0051675	0001224	LAKE CITY HUMANE SOCIETY,	001649		3/13/2024	31,312.50	31,312.50	31,312.50
0051676	0001230	LAKE CITY INDUSTRIES	3941	P45838	3/13/2024	2.79		
			3942	P45838	3/13/2024	4.78		
			3948	P45837	3/13/2024	43.43	51.00	51.00
0051677	0001204	LAKE CITY REPORTER, INC.	001690		3/13/2024	767.58		
			001691		3/13/2024	207.08		
			001692		3/13/2024	227.87		
			001693		3/13/2024	202.79		
			001694		3/13/2024	181.50		
			001695		3/13/2024	207.08		
			001696		3/13/2024	218.79		
			001697		3/13/2024	263.43		
			001698		3/13/2024	209.70		
			001699		3/13/2024	285.45		
			001700		3/13/2024	87.85		
			001701		3/13/2024	87.85		
			001702		3/13/2024	87.85		
			001702		3/13/2024	115.44		
			001702		3/13/2024	57.72		
			001702		3/13/2024	115.44		
			001702		3/13/2024	87.85	3,411.27	3,411.27
0051678	0004710	LAWSON PRODUCTS, INC.	4128	P45586	3/13/2024	249.15	249.15	249.15
0051679	0003020	LEVY JONES	3955	P45891	3/13/2024	262.77	262.77	262.77
0051680	0005493	LEWIS MURRAY TIRE, LLC	4048	P45907	3/13/2024	60.00	60.00	60.00
0051681	0005422	LINDA IVERY	4157	P45968	3/13/2024	522.00	522.00	522.00
0051682	0003774	LIQUID ENVIRONMENTAL SOLU	PI3911	027261	3/13/2024	1,059.72		
			PI3912	027261	3/13/2024	976.92		
			PI3913	027261	3/13/2024	971.35		
			PI3914	027261	3/13/2024	981.48		
			PI3915	027261	3/13/2024	1,011.24		
			PI3916	027261	3/13/2024	989.32		
			PI3917	027261	3/13/2024	1,001.24		

PROGRAM GM344LR  
COLUMBIA COUNTY  
BANK 00

CHECK NO	VENDOR NO	VENDOR NAME	VOUCHER NO	P.O. NO	DATE	VOUCHER AMOUNT	REMITTANCE AMOUNT	CHECK TOTAL
0051682	0003774	LIQUID ENVIRONMENTAL	SOLUPI3918	027300	3/13/2024	973.66		
			PI3919	027300	3/13/2024	972.68		
			PI4027	027300	3/13/2024	975.00		
			PI4028	027300	3/13/2024	993.99		
			PI4029	027300	3/13/2024	1,007.05		
			PI4030	027300	3/13/2024	1,003.39		
			PI4031	027300	3/13/2024	987.80		
			PI4055	027300	3/13/2024	983.24		
			PI4056	027300	3/13/2024	990.92		
			PI4057	027300	3/13/2024	1,003.00	16,882.00	16,882.00
0051683	0005903	LIVE OAK INVESTMENTS	14154256	P46157	3/13/2024	2,752.00	2,752.00	2,752.00
0051684	0006033	LOGOKICK.COM LLC	4169	P46070	3/13/2024	850.60	850.60	850.60
0051685	0001262	LOWE'S PROX	3939	P45843	3/13/2024	350.27		
			3940	P45859	3/13/2024	28.46		
			3943	P45844	3/13/2024	41.66		
			3945	P45848	3/13/2024	12.33		
			3946	P45849	3/13/2024	12.33-		
			3950	P45853	3/13/2024	151.05		
			3975	P45898	3/13/2024	19.32		
			4026	P45882	3/13/2024	397.91		
			4147	P46004	3/13/2024	26.34		
			4170	P46078	3/13/2024	40.81	1,055.82	1,055.82
0051686	0001216	LUBE SPECIALISTS	4129	P45619	3/13/2024	113.00		
			4132	P45690	3/13/2024	859.64		
			4133	P45802	3/13/2024	72.35		
			4134	P45768	3/13/2024	441.43		
			4135	P45812	3/13/2024	142.28	1,628.70	1,628.70
0051687	0006272	MARILYN FRAZIER	4218	P45969	3/13/2024	120.00	120.00	120.00
0051688	0001317	HENRY SHEIN, INC./DBA MAT	4086	P46022	3/13/2024	15.44-		
			4183	P46105	3/13/2024	35.52		
			4185	P46106	3/13/2024	76.15	96.23	96.23
0051689	0003135	MAYO FERTILIZER, INC.	4178	P45368	3/13/2024	38.00		
			4188	P45769	3/13/2024	76.00	114.00	114.00
0051690	0001319	MCCRIMON'S OFFICE SUPPLY	001651		3/13/2024	32.30		
			001652		3/13/2024	54.74		
			001653		3/13/2024	192.03		
			001654		3/13/2024	29.85		
			001795		3/13/2024	210.27		
			4195	P45997	3/13/2024	46.56		
			4260	P46161	3/13/2024	143.57		
			4261	P46162	3/13/2024	59.09	768.41	768.41
0051691	0005923	METAL CULVERTS, INC.	PI3905	027226	3/13/2024	29,733.50	29,733.50	29,733.50
0051692	0001351	METAL MASTERS OF FLORIDA	3944	P45847	3/13/2024	130.24	130.24	130.24
0051693	0004503	METZ,HUSBAND& DAUGHTON,P.	001796		3/13/2024	6,745.00	6,745.00	6,745.00
0051694	0001329	MIDWEST TAPE EXCHANGE	PI3958	027083	3/13/2024	94.55		
			PI3959	027084	3/13/2024	284.52		
			PI4106	027083	3/13/2024	19.94		
			PI4107	027084	3/13/2024	16.19	415.20	415.20
0051695	0001347	MINI-STORAGE/RECORD STORA	001815		3/13/2024	45.00		
			001816		3/13/2024	45.00		
			001816		3/13/2024	45.00		
			001816		3/13/2024	45.00		

PROGRAM GM344LR  
COLUMBIA COUNTY  
BANK 00

CHECK NO	VENDOR NO	VENDOR NAME	VOUCHER NO	P.O. NO	DATE	VOUCHER AMOUNT	REMITTANCE AMOUNT	CHECK TOTAL
0051695	0001347	MINI-STORAGE/RECORD STORA	001816		3/13/2024	45.00		
			001816		3/13/2024	45.00		
			001816		3/13/2024	45.00	315.00	315.00
0051696	0004942	MUNICIPAL EMERGENCY SERVI	3956	P45890	3/13/2024	850.00		
			4242	P46107	3/13/2024	688.00	1,538.00	1,538.00
0051697	0002991	MYERS TOOL & SERVICE	PI3963	027227	3/13/2024	185.00		
			PI3964	027227	3/13/2024	3,235.95		
			4190	P45981	3/13/2024	32.00	3,452.95	3,452.95
0051698	0000182	NAPA AUTO PARTS FORT WHIT	4182	P46103	3/13/2024	26.98	26.98	26.98
0051699	0001434	NE-RO TIRE & BRAKE SERVIC	3980	P45682	3/13/2024	2,331.08		
			3982	P45680	3/13/2024	432.02		
			3983	P45684	3/13/2024	300.00		
			4020	P45862	3/13/2024	552.00		
			4213	P45955	3/13/2024	717.54	4,332.64	4,332.64
0051700	0001432	NEFLIN, INC.	4205	P45940	3/13/2024	135.00	135.00	135.00
0051701	0001429	NEXTRAN TRUCK CENTER	3977	P45612	3/13/2024	201.60		
			3979	P45864	3/13/2024	110.00-		
			3998	P45799	3/13/2024	398.40		
			4004	P45676	3/13/2024	978.82		
			4214	P45958	3/13/2024	52.68	1,521.50	1,521.50
0051702	0003173	NICOLE E. CALLUM	4219	P45975	3/13/2024	120.00	120.00	120.00
0051703	0001439	NORTH FLORIDA FENCE	PI4053	027290	3/13/2024	3,050.00		
			4079	P46044	3/13/2024	2,160.00	5,210.00	5,210.00
0051704	0001018	NORTH FLORIDA GLASS	4177	P45804	3/13/2024	335.76	335.76	335.76
0051705	0003663	NORTH FLORIDA PROFESSIONA	001814		3/13/2024	38,577.00	38,577.00	38,577.00
0051706	0001616	O'NEAL ROOFING CO., INC.	PI3961	027285	3/13/2024	44,425.80	44,425.80	44,425.80
0051707	0006029	ODP BUSINESS SOLUTIONS, L	3903	P45808	3/13/2024	51.90		
			4001	P45825	3/13/2024	27.59		
			4002	P45825	3/13/2024	51.11		
			4037	P45927	3/13/2024	64.00		
			4038	P45929	3/13/2024	131.76		
			4039	P45930	3/13/2024	50.65		
			4041	P45790	3/13/2024	116.81		
			4042	P45936	3/13/2024	25.19		
			4179	P45439	3/13/2024	55.34		
			4210	P46139	3/13/2024	154.41		
			4211	P46140	3/13/2024	19.99		
			4212	P46141	3/13/2024	33.98		
			4216	P45963	3/13/2024	127.48		
			4235	P46094	3/13/2024	39.89		
			4236	P46094	3/13/2024	139.09	1,089.19	1,089.19
0051708	0004881	OPTIMUM WATER SOLUTIONS,	4201	P46014	3/13/2024	96.00	96.00	96.00
0051709	0005864	PARADISE ADVERTISING & MA	PI4109	027126	3/13/2024	2,163.00		
			PI4110	027126	3/13/2024	700.00	2,863.00	2,863.00
0051710	0005911	PARKING BOXX CORP.	4075	P46046	3/13/2024	200.00	200.00	200.00
0051711	0001707	PELONI'S PUMPING	4066	P46035	3/13/2024	475.00	475.00	475.00
0051712	0001041	PETE OLIN AUTO PARTS, INC	3984	P45691	3/13/2024	26.44		
			3985	P45716	3/13/2024	22.34		
			3991	P45766	3/13/2024	799.00		
			3992	P45767	3/13/2024	650.00		
			3993	P45861	3/13/2024	150.00-		
			4078	P46045	3/13/2024	33.28	1,381.06	1,381.06

PROGRAM GM344LR  
 COLUMBIA COUNTY  
 BANK 00

CHECK NO	VENDOR NO	VENDOR NAME	VOUCHER NO	P.O. NO	DATE	VOUCHER AMOUNT	REMITTANCE AMOUNT	CHECK TOTAL
0051713	0006281	PILLARS WELDING	4187	P45991	3/13/2024	550.00	550.00	550.00
0051714	0005930	POWERHOUSE PEST CONTROL	I3953	P45883	3/13/2024	35.00		
			3954	P45884	3/13/2024	35.00		
			4092	P46023	3/13/2024	50.00		
			4093	P46024	3/13/2024	35.00		
			4099	P46026	3/13/2024	45.00		
			4100	P46027	3/13/2024	50.00		
			4102	P46028	3/13/2024	35.00		
			4237	P46102	3/13/2024	35.00		
			4238	P46104	3/13/2024	35.00	355.00	355.00
0051715	0002220	PRECISION CHEMICALS	4091	P45914	3/13/2024	59.99		
			4200	P45905	3/13/2024	145.98		
			4233	P46072	3/13/2024	22.99	228.96	228.96
0051716	0004063	PREMIER PAPER & JANITORIA	3957	P45892	3/13/2024	370.47		
			3994	P45764	3/13/2024	584.94		
			4059	P46029	3/13/2024	221.89		
			4060	P46031	3/13/2024	77.99		
			4061	P46032	3/13/2024	58.00		
			4224	P46050	3/13/2024	85.98	1,399.27	1,399.27
0051717	0001793	PREMIER WATER & ENERGY TE	4014	P45922	3/13/2024	568.37	568.37	568.37
0051718	0004345	PRITCHETT TRUCKING, INC.	PI4052	027076	3/13/2024	1,645.00	1,645.00	1,645.00
0051719	0006276	PROFESSIONAL DEVELOPMENT	PI4117	027316	3/13/2024	2,745.00	2,745.00	2,745.00
0051720	0005268	PUBLIC SAFETY GROUP	4076	P46052	3/13/2024	80.00	80.00	80.00
0051721	0001805	QUILL	4010	P45820	3/13/2024	199.92	199.92	199.92
0051722	0001183	RELIABLE SHREDDING SERVIC	4049	P45948	3/13/2024	613.00		
			4228	P46120	3/13/2024	80.50	693.50	693.50
0051723	0003415	RICHARDSON PAINT	3937	P45839	3/13/2024	22.32	22.32	22.32
0051724	0001907	RING POWER CORP.	PI3965	027064	3/13/2024	197,900.00		
			3969	P45251	3/13/2024	684.08		
			3971	P45390	3/13/2024	1,380.74		
			4044	P45949	3/13/2024	914.02		
			PI4111	027150	3/13/2024	241,097.00		
			4191	P45830	3/13/2024	126.69		
			4221	P46089	3/13/2024	486.33		
			4229	P46136	3/13/2024	142.87	442,731.73	442,731.73
0051725	0001911	ROUNTREE-MOORE FORD	4016	P45832	3/13/2024	205.00	205.00	205.00
0051726	0006261	NORTH CENTRAL EMS CORPORA	4090	P46025	3/13/2024	464.99	464.99	464.99
0051727	0006192	SEARCHWIDE GLOBAL	PI3907	027062	3/13/2024	9,665.05	9,665.05	9,665.05
0051728	0004796	SHARP ELECTRONICS CORPOR	PI3910	027228	3/13/2024	104.69		
			PI3960	027108	3/13/2024	147.71		
			4217	P45965	3/13/2024	110.64	363.04	363.04
0051729	0002021	SHERWIN-WILLIAMS CO.STORE	4019	P45836	3/13/2024	78.57	78.57	78.57
0051730	0005026	SOLITUDE LAKE MANAGEMENT	4067	P46036	3/13/2024	208.80		
			4068	P46037	3/13/2024	224.10		
			4069	P46039	3/13/2024	265.50	698.40	698.40
0051731	0000287	SOUTHERN SPECIALIZED LLC	PI4080	027148	3/13/2024	940.59		
			PI4081	027148	3/13/2024	7,242.18		
			PI4082	027148	3/13/2024	7,100.78	15,283.55	15,283.55
0051732	0003610	STANLEY CRAWFORD	4255	P46156	3/13/2024	3,831.33	3,831.33	3,831.33
0051733	0001198	STATE ATTORNEY'S OFFICE (	001578		3/13/2024	9,598.75	9,598.75	9,598.75
0051734	0002022	STATE ATTORNEY'S OFFICE-F	001577		3/13/2024	2,711.70	2,711.70	2,711.70
0051735	0006087	STAZ GUNTEK	4180	P45442	3/13/2024	106.08		

CHECK NO	VENDOR NO	VENDOR NAME	VOUCHER NO	P.O. NO	DATE	VOUCHER AMOUNT	REMITTANCE AMOUNT	CHECK TOTAL
0051735	0006087	STAZ GUNTEK	4181	P45443	3/13/2024	148.54	254.62	254.62
0051736	0008512	SUWANNEE RIVER ECONOMIC	C001685		3/13/2024	14,339.59		
			001686		3/13/2024	14,700.00		
			001687		3/13/2024	14,200.00		
			001688		3/13/2024	10,300.00		
			001713		3/13/2024	14,900.00	68,439.59	68,439.59
0051737	0002028	SUWANNEE VALLEY ELECT. CO	0000253		3/13/2024	526.00		
			000254		3/13/2024	62.00		
			000255		3/13/2024	183.00		
			000256		3/13/2024	467.00		
			000257		3/13/2024	168.00		
			000258		3/13/2024	49.00		
			000259		3/13/2024	12.77		
			000260		3/13/2024	12.77		
			000261		3/13/2024	12.77		
			000262		3/13/2024	101.00		
			000263		3/13/2024	165.00		
			000264		3/13/2024	242.00		
			000265		3/13/2024	229.00		
			000266		3/13/2024	226.00		
			000267		3/13/2024	51.00		
			000268		3/13/2024	189.00		
			000269		3/13/2024	245.00		
			000270		3/13/2024	307.00	3,248.31	3,248.31
0051738	0006065	SYNERGY DISASTER RECOVERY	001655		3/13/2024	4,720.00	4,720.00	4,720.00
0051739	0006023	THE ADT SECURITY CORPORAT	4264	P46172	3/13/2024	170.10	170.10	170.10
0051740	0005203	THE LAW OFFICE OF JOEL F.	001656		3/13/2024	1,650.00	1,650.00	1,650.00
0051741	0001458	TOM NEHL TRUCK COMPANY	4000	P45805	3/13/2024	260.50	260.50	260.50
0051742	0002552	TOWNSEND PRESS	4198	P45876	3/13/2024	94.43	94.43	94.43
0051743	0005157	TWO FOLD WATER ENGINEERIN	4202	P46019	3/13/2024	1,400.00		
			4203	P46020	3/13/2024	1,475.00		
			4220	P46018	3/13/2024	1,020.00	3,895.00	3,895.00
0051744	0004180	ULINE	4040	P45931	3/13/2024	177.26		
			4087	P45932	3/13/2024	1,373.48	1,550.74	1,550.74
0051745	0003989	UNIFIRST CORPORATION	3906	P45809	3/13/2024	54.95		
			3951	P45854	3/13/2024	72.37		
			3952	P45855	3/13/2024	174.21		
			3986	P45826	3/13/2024	15.74		
			4022	P45900	3/13/2024	29.68		
			4023	P45901	3/13/2024	16.87		
			4046	P45908	3/13/2024	367.05		
			4047	P45926	3/13/2024	54.95		
			4065	P46033	3/13/2024	70.98		
			4077	P46040	3/13/2024	276.21		
			4189	P46011	3/13/2024	611.59		
			4194	P45941	3/13/2024	15.74		
			4206	P46007	3/13/2024	174.21		
			4207	P46008	3/13/2024	72.37		
			4208	P46010	3/13/2024	866.22		
			4225	P46056	3/13/2024	101.73		
			4230	P46143	3/13/2024	54.95		
			4240	P46095	3/13/2024	29.68		

PROGRAM GM344LR  
COLUMBIA COUNTY  
BANK 00

CHECK NO	VENDOR NO	VENDOR NAME	VOUCHER NO	P.O. NO	DATE	VOUCHER AMOUNT	REMITTANCE AMOUNT	CHECK TOTAL
0051745	0003989	UNIFIRST CORPORATION	4241	P46096	3/13/2024	15.74	3,075.24	3,075.24
0051746	0004909	UNITED REFRIGERATION, INC	3920	P45857	3/13/2024	55.20		
			3928	P45856	3/13/2024	85.63		
			3930	P45828	3/13/2024	80.40		
			3933	P45888	3/13/2024	71.64	292.87	292.87
0051747	0006279	VANQUIECE BROWN	4234	P46082	3/13/2024	58.07	58.07	58.07
0051748	0002673	VERIZON WIRELESS	4254	P46155	3/13/2024	619.40	619.40	619.40
0051749	0001152	WASTE PRO - LAKE CITY	001797		3/13/2024	4,374.93	4,374.93	4,374.93
0051750	0005623	WESCO TURF INC.	PI4032	027302	3/13/2024	8,764.00		
			PI4033	027302	3/13/2024	8,864.00	17,628.00	17,628.00
0051751	0006043	WHARTON-SMITH, INC.	PI4116	027313	3/13/2024	724,556.76	724,556.76	724,556.76
0051752	0002462	WHITEHEAD HARDWARE COMPAN	4199	P45904	3/13/2024	452.52	452.52	452.52
0051753	0000129	WINDSTREAM	001672		3/13/2024	95.07		
			001673		3/13/2024	179.01		
			001676		3/13/2024	213.67		
			4192	P45944	3/13/2024	164.00		
			4222	P46113	3/13/2024	132.01	783.76	783.76
0051754	0005973	WINDSTREAM	4253	P46154	3/13/2024	410.48	410.48	410.48
0051755	0003387	WINDSTREAM . 2	4252	P46153	3/13/2024	169.94	169.94	169.94
0051756	0005190	WINSUPPLY	3934	P45858	3/13/2024	10.52		
			4012	P45920	3/13/2024	23.16		
			4024	P45917	3/13/2024	715.39		
			001709		3/13/2024	26.35-		
			4196	P46006	3/13/2024	15.80		
			4209	P46069	3/13/2024	145.13	883.65	883.65
0051757	0002500	XEROX CORP	001708		3/13/2024	205.03	205.03	205.03
0051758	0003551	ZEP SALES & SERVICE	3935	P45860	3/13/2024	441.60	441.60	441.60
0051759	0006212	ZOIE WHITLOCK	4215	P45961	3/13/2024	278.30	278.30	278.30
						TOTAL CHECKS	176	3,759,194.74



# COLUMBIA COUNTY BOARD OF COUNTY COMMISSIONERS AGENDA ITEM REQUEST FORM

The Board of County Commissioners meets the 1st and 3rd Thursday of each month in the Columbia County School Board Administrative Complex Auditorium, 372 West Duval Street, Lake City, Florida 32055. The first meeting of every month is at 9:30AM while the second meeting of every month takes place at 5:30PM. All agenda items are due in the Board's office one week prior to the meeting date.

Today's Date: 3/4/2024 Meeting Date: 3/21/2024

Department: Public Works

### 1. Nature and purpose of agenda item:

BA 24-32 FDACS Budget Amendment form #13613 in regards to carry-forward of funds from FY22/23 to FY23/24; State funds (\$2,919) and Local funds (\$17,436) as required by F.S. 388.311. Also, included on the form is an increase in State funds (\$5,000) non-capital equipment for Ipad upgrades and Local funds (\$2,583) workers comp to match the FY23/24 County Budget.

### 2. Recommended Motion/Action:

Approve BA 24-32

### 3. Fiscal impact on current budget.

This item is not budgeted. The proposed budget amendment to fund this request is provided below. The budget amendment number is BA 24-32 using fund(s) 001-GENERAL FUND.

FROM:	TO:	AMOUNT:
001-8400-584.90-98 RESERVES/CASH BALANCE FORWARD	001-6200-562.30-62 OPERATING EXPENDITURES/CHEMICALS	\$17,436.00
001-8400-584.90-98 RESERVES/CASH BALANCE FORWARD	001-6201-562.30-62 OPERATING EXPENDITURES/CHEMICALS	\$2,919.00

District No. 1 - Ronald Williams  
District No. 2 - Rocky Ford  
District No. 3 - Robby Hollingsworth  
District No. 4 - Everett Phillips  
District No. 5 - Tim Murphy

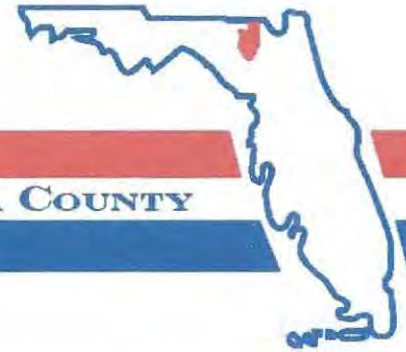

**BOARD OF COUNTY COMMISSIONERS • COLUMBIA COUNTY**

MEMORANDUM

TO: David Kraus, County Manager

FROM: Kevin Kirby, Assistant County Manager / ↙

DATE: March 1, 2024

RE: Budget Amendment Mosquito Control Carry-Forward from FY22/23 to FY23/24

---

Please find attached FDACS Budget Amendment form #13613 in regards to carry-forward of funds from FY22/23 to FY23/24; State funds (\$2,919) and Local funds (\$17,436) as required by F.S. 388.311.

Also, included on the form is an increase in State funds (\$5,000) non-capital equipment for iPad upgrades and Local funds (\$2,583) workers comp to match the FY23/24 County Budget.

Should you need any additional information, please feel free to contact me.

BOARD MEETS FIRST AND THIRD THURSDAY AT 5:30 P.M.

P.O. BOX 1529

LAKE CITY, FLORIDA 32056-1529

PHONE (386) 755-4100



District No. 1 - Ronald Williams  
District No. 2 - Rocky Ford  
District No. 3 - Robby Hollingsworth  
District No. 4 - Everett Phillips  
District No. 5 - Tim Murphy



**BOARD OF COUNTY COMMISSIONERS • COLUMBIA COUNTY**

MEMORANDUM

TO: Kevin Kirby, Assistant County Manager

FR: Pam Davis, Solid Waste Director 

DATE: February 29, 2024

RE: Budget Amendment Mosquito Control  
Carry-Forward from FY22/23 to FY23/24

---

Please find attached FDACS Budget Amendment form #13613 in regards to carry-forward of funds from FY22/23 to FY23/24; State funds (\$2,919) and Local funds (\$17,436) as required by F.S. 388.311.

Also, included on the form is an increase in State funds (\$5,000) non-capital equipment for iPad upgrades and Local funds (\$2,583) workers comp to match the FY23/24 County Budget.

If any additional information is needed, please let me know.

XC: FY23/24 Mosquito Control Budget

BOARD MEETS FIRST AND THIRD THURSDAY AT 5:30 P.M.

P.O. BOX 1529

LAKE CITY, FLORIDA 32056-1529

PHONE (386) 755-4100

**ROLL FORWARD BUDGET AMENDMENT**

NUMBER: BA-  
 FUND: 001: Mosquito

	Account #	CarryForward from FY22/23	TO FY23/24 Reallocation Amount
	001-6200-562.10-12 <b>Local/Personal Services</b>	\$12,833	
	001-6200-562.10-21 <b>Local/FICA</b>	\$3,995	
	001-6200-562.10-22 <b>Local/Travel &amp; PerDiem</b>	\$945	
	001-6200-562.10-23 <b>Local/Health &amp; Life</b>	(\$0.03)	
	001-6200-562.10-24 <b>Local/Workmens Comp</b>	(\$882)	
	001-6200-562.30-46 <b>Local/Repairs &amp; Maint</b>	\$220	
	001-6200-562.30-49 <b>Local/Other Charges</b>	\$800	
	001-6200-562.30-52 <b>Local/Operating Supplies</b>	(\$486)	
	001-6200-562.30-62 <b>Local/Chemical</b>	\$11	\$17,436
001-8400-584.90-98 Reserves/Cash Bal Forward	<b>Total Local Carry-Forward</b>	<b>\$17,436</b>	<b>\$17,436</b>
	001-6201-562.30-40 <b>State/Travel &amp; Per Diem</b>	\$1,500	
	001-6201-562.30-46 <b>State/Repair &amp; Maint</b>	\$70	
	001-6201-562.30-49 <b>State/Other Charges</b>	\$500	
	001-6201-562.30-52 <b>State/Operating Supplies</b>	\$884	
	001-6201-562.30-55 <b>State/Training</b>	(\$35)	
	001-6201-562.30-56 <b>State/Gas &amp; Oil</b>	\$0.30	
	001-6201-562.30-62 <b>State/Chemicals</b>	\$0	\$2,919
001-8400-584.90-98 Reserves/Cash Bal Forward	<b>Total State Carry-Forward</b>	<b>\$2,919</b>	<b>\$2,919</b>
	<b>Total LOCAL/STATE Carry-forward</b>	<b>\$20,355</b>	<b>\$20,355</b>

DESCRIPTION: Roll-Forward amount \$20,335; State(\$2,919) Mosquito Control Grant Funds and Local (\$17,436) Mosquito Control,

REFERENCE: As Required by F.S. 388.311.

Requested By: Pam Davis



Florida Department of Agriculture and Consumer Services  
Division of Agricultural Environmental Services

**ARTHROPOD CONTROL BUDGET AMENDMENT**

Submit to:  
Mosquito Control Program  
MosquitoControlReports@FDACS.gov  
3125 Conner Blvd, Suite E  
Tallahassee, FL 32399-1650

WILTON SIMPSON  
COMMISSIONER

Rule 5E-13.027, F.A.C.  
Telephone: (850) 617-7911; Fax (850) 617-7939

A STATEMENT EXPLAINING AND JUSTIFYING THE PROPOSED CHANGES SHOULD ACCOMPANY EACH APPLICATION FOR BUDGET AMENDMENT.

Amendment No. 1 Fiscal Year 20 23 - 20 24 Date February 28, 2024

Amending: Local Funds      State Funds X (Check appropriate fund account to be amended. Use a separate form for each fund).

The Board of Commissioners for: Columbia County hereby submits to the Department of Agriculture and Consumer Services, Mosquito Control Program for its consideration and approval, the following amendment for the current fiscal year as follows:

**ESTIMATED RECEIPTS**

NOTE: The budget cannot be amended to show an increase in receipts over the amount budgeted unless authorized.

Total Available Cash and Receipts	Reserves	Present Budget	Increase Request	Decrease Request	Revised Budget
\$ 37,748.53	\$ -	\$ 37,748.53	\$ 7,919.00	\$ 5,000.00	\$ <b>40,667.53</b>

NAME SOURCE OF INCREASE: (Explain Decrease) Carry Forward from FY22/23 \$2,919 and \$5K non-capital equipment to match county budget

**BUDGETED RECEIPTS**

ACCT NO	Description	Present Budget	Increase Request	Decrease Request	Revised Budget
311	Ad Valorem (Current/Delinquent)	\$ -	\$ -	\$ -	\$ -
334.1	State Grant	\$ 37,748.53	\$ 7,919.00	\$ 5,000.00	\$ 40,667.53
362	Equipment Rentals	\$ -	\$ -	\$ -	\$ -
337	Grants and Donations	\$ -	\$ -	\$ -	\$ -
361	Interest Earnings	\$ -	\$ -	\$ -	\$ -
364	Equipment and/or Other Sales	\$ -	\$ -	\$ -	\$ -
369	Misc./Refunds (prior yr expenditures)	\$ -	\$ -	\$ -	\$ -
380	Other Sources	\$ -	\$ -	\$ -	\$ -
389	Loans	\$ -	\$ -	\$ -	\$ -
<b>TOTAL RECEIPTS</b>		\$ 37,748.53	\$ 7,919.00	\$ 5,000.00	\$ 40,667.53
Beginning Fund Balance		\$ -	\$ -	\$ -	\$ -
<b>Total Budgetary Receipts &amp; Balances</b>		\$ 37,748.53	\$ 7,919.00	\$ 5,000.00	\$ 40,667.53

**BUDGETED EXPENDITURES**

NOTE: Total increase must equal total decrease, unless the total "Present Budget" is revised.

ACCT NO	Uniform Accounting System Transaction	Present Budget	Increase Request	Decrease Request	Revised Budget
10	Personal Services	\$ -	\$ -	\$ -	\$ -
20	Personal Services Benefits	\$ -	\$ -	\$ -	\$ -
30	Operating Expense	\$ -	\$ -	\$ -	\$ -
40	Travel & Per Diem	\$ 500.00	\$ -	\$ -	\$ 500.00
41	Communication Services	\$ -	\$ -	\$ -	\$ -
42	Freight Services	\$ -	\$ -	\$ -	\$ -
43	Utility Service	\$ -	\$ -	\$ -	\$ -
44	Rentals & Leases	\$ -	\$ -	\$ -	\$ -
45	Insurance	\$ -	\$ -	\$ -	\$ -
46	Repairs & Maintenance	\$ 3,500.00	\$ -	\$ -	\$ 3,500.00
47	Printing and Binding	\$ -	\$ -	\$ -	\$ -
48	Promotional Activities	\$ -	\$ -	\$ -	\$ -
49	Other Charges	\$ 500.00	\$ -	\$ -	\$ 500.00
51	Office Supplies	\$ -	\$ -	\$ -	\$ -
52.1	Gasoline/OIL/Lube	\$ 3,690.00	\$ -	\$ -	\$ 3,690.00
52.2	Chemicals	\$ 28,158.53	\$ 2,919.00	\$ 5,000.00	\$ 26,077.53
52.3	Protective Clothing	\$ -	\$ -	\$ -	\$ -
52.4	Misc. Supplies	\$ 500.00	\$ -	\$ -	\$ 500.00
52.5	Tools & Implements	\$ -	\$ -	\$ -	\$ -
54	Publications & Dues	\$ 500.00	\$ -	\$ -	\$ 500.00
55	Training	\$ 400.00	\$ -	\$ -	\$ 400.00
60	Capital Outlay	\$ -	\$ 5,000.00	\$ -	\$ 5,000.00
71	Principal	\$ -	\$ -	\$ -	\$ -
72	Interest	\$ -	\$ -	\$ -	\$ -
81	Aids to Government Agencies	\$ -	\$ -	\$ -	\$ -
83	Other Grants and Aids	\$ -	\$ -	\$ -	\$ -
89	Contingency (Current Year)	\$ -	\$ -	\$ -	\$ -
99	Payment of Prior Year Accounts	\$ -	\$ -	\$ -	\$ -
Other	Please Select Other Accounting Code	\$ -	\$ -	\$ -	\$ -
Other	Please Select Other Accounting Code	\$ -	\$ -	\$ -	\$ -
Other	Please Select Other Accounting Code	\$ -	\$ -	\$ -	\$ -
<b>TOTAL BUDGET AND CHARGES</b>		\$ 37,748.53	\$ 7,919.00	\$ 5,000.00	\$ 40,667.53
0.001	Reserves - Future Capital Outlay	\$ -	\$ -	\$ -	\$ -
0.002	Reserves - Self-Insurance	\$ -	\$ -	\$ -	\$ -
0.003	Reserves - Cash Balance to be Carried Forward	\$ -	\$ -	\$ -	\$ -
0.004	Reserves - Sick and Annual Leave	\$ -	\$ -	\$ -	\$ -
<b>TOTAL RESERVES</b>		\$ -	\$ -	\$ -	\$ -
<b>TOTAL BUDGETARY EXPENDITURES and BALANCES</b>		\$ 37,748.53	\$ 7,919.00	\$ 5,000.00	\$ -
<b>ENDING FUND BALANCE</b>		\$ -	\$ -	\$ -	\$ 40,667.53

APPROVED: \_\_\_\_\_ DATE \_\_\_\_\_  
Chairman of the Board, or Clerk of Circuit Court

APPROVED: \_\_\_\_\_ DATE \_\_\_\_\_  
FDACS Mosquito Control Program Representative



Florida Department of Agriculture and Consumer Services  
Division of Agricultural Environmental Services

**ARTHROPOD CONTROL BUDGET AMENDMENT**

Submit to:  
Mosquito Control Program  
MosquitoControlReports@FDACS.gov  
3125 Conner Blvd, Suite E  
Tallahassee, FL 32399-1650

WILTON SIMPSON  
COMMISSIONER

Rule 5E-13.027, F.A.C.  
Telephone: (850) 817-7911; Fax (850) 817-7939

A STATEMENT EXPLAINING AND JUSTIFYING THE PROPOSED CHANGES SHOULD ACCOMPANY EACH APPLICATION FOR BUDGET AMENDMENT.

Amendment No. 2 Fiscal Year 20\_23\_ - 20\_24\_ Date February 28, 2024

Amending: Local Funds  State Funds  (Check appropriate fund account to be amended. Use a separate form for each fund).

The Board of Commissioners for: Columbia County hereby submits to the Department of Agriculture and Consumer Services, Mosquito Control Program for its consideration and approval, the following amendment for the current fiscal year as follows:

**ESTIMATED RECEIPTS**

NOTE: The budget cannot be amended to show an increase in receipts over the amount budgeted unless authorized.

Total Available Cash and Receipts	Reserves	Present Budget	Increase Request	Decrease Request	Revised Budget
\$ 111,902.12	\$ -	\$ 111,902.12	\$ 20,019.00	\$ -	\$ 131,921.12

NAME SOURCE OF INCREASE: (Explain Decrease) Carry Forward from FY22/23 +\$17,436 and +\$2,583 in Personal Services to match County

**BUDGETED RECEIPTS**

ACCT NO	Description	Present Budget	Increase Request	Decrease Request	Revised Budget
311	Ad Valorem (Current/Delinquent)	\$ 111,902.12	\$ 20,019.00	\$ -	\$ 131,921.12
334.1	State Grant	\$ -	\$ -	\$ -	\$ -
362	Equipment Rentals	\$ -	\$ -	\$ -	\$ -
337	Grants and Donations	\$ -	\$ -	\$ -	\$ -
361	Interest Earnings	\$ -	\$ -	\$ -	\$ -
364	Equipment and/or Other Sales	\$ -	\$ -	\$ -	\$ -
369	Misc./Refunds (prior yr expenditures)	\$ -	\$ -	\$ -	\$ -
380	Other Sources	\$ -	\$ -	\$ -	\$ -
389	Loans	\$ -	\$ -	\$ -	\$ -
<b>TOTAL RECEIPTS</b>		\$ 111,902.12	\$ 20,019.00	\$ -	\$ 131,921.12
Beginning Fund Balance		\$ -	\$ -	\$ -	\$ -
<b>Total Budgetary Receipts &amp; Balances</b>		\$ 111,902.12	\$ 20,019.00	\$ -	\$ 131,921.12

**BUDGETED EXPENDITURES**

NOTE: Total increase must equal total decrease, unless the total "Present Budget" is revised.

ACCT NO	Uniform Accounting System Transaction	Present Budget	Increase Request	Decrease Request	Revised Budget
10	Personal Services	\$ 46,800.00	\$ -	\$ -	\$ 46,800.00
20	Personal Services Benefits	\$ 9,402.12	\$ 2,583.00	\$ -	\$ 11,985.12
30	Operating Expense	\$ 300.00	\$ -	\$ -	\$ 300.00
40	Travel & Per Diem	\$ 500.00	\$ -	\$ -	\$ 500.00
41	Communication Services	\$ 3,100.00	\$ -	\$ -	\$ 3,100.00
42	Freight Services	\$ -	\$ -	\$ -	\$ -
43	Utility Service	\$ -	\$ -	\$ -	\$ -
44	Rentals & Leases	\$ -	\$ -	\$ -	\$ -
45	Insurance	\$ -	\$ -	\$ -	\$ -
46	Repairs & Maintenance	\$ 5,000.00	\$ -	\$ -	\$ 5,000.00
47	Printing and Binding	\$ -	\$ -	\$ -	\$ -
48	Promotional Activities	\$ -	\$ -	\$ -	\$ -
49	Other Charges	\$ 400.00	\$ -	\$ -	\$ 400.00
51	Office Supplies	\$ -	\$ -	\$ -	\$ -
52.1	Gasoline/Oil/Lube	\$ 5,000.00	\$ -	\$ -	\$ 5,000.00
52.2	Chemicals	\$ 40,000.00	\$ 17,436.00	\$ -	\$ 57,436.00
52.3	Protective Clothing	\$ -	\$ -	\$ -	\$ -
52.4	Misc. Supplies	\$ 500.00	\$ -	\$ -	\$ 500.00
52.5	Tools & Implements	\$ -	\$ -	\$ -	\$ -
54	Publications & Dues	\$ 500.00	\$ -	\$ -	\$ 500.00
55	Training	\$ 400.00	\$ -	\$ -	\$ 400.00
60	Capital Outlay	\$ -	\$ -	\$ -	\$ -
71	Principal	\$ -	\$ -	\$ -	\$ -
72	Interest	\$ -	\$ -	\$ -	\$ -
81	Aids to Government Agencies	\$ -	\$ -	\$ -	\$ -
83	Other Grants and Aids	\$ -	\$ -	\$ -	\$ -
89	Contingency (Current Year)	\$ -	\$ -	\$ -	\$ -
99	Payment of Prior Year Accounts	\$ -	\$ -	\$ -	\$ -
Other	Please Select Other Accounting Code	\$ -	\$ -	\$ -	\$ -
Other	Please Select Other Accounting Code	\$ -	\$ -	\$ -	\$ -
Other	Please Select Other Accounting Code	\$ -	\$ -	\$ -	\$ -
<b>TOTAL BUDGET AND CHARGES</b>		\$ 111,902.12	\$ 20,019.00	\$ -	\$ 131,921.12
0.001	Reserves - Future Capital Outlay	\$ -	\$ -	\$ -	\$ -
0.002	Reserves - Self-Insurance	\$ -	\$ -	\$ -	\$ -
0.003	Reserves - Cash Balance to be Carried Forward	\$ -	\$ -	\$ -	\$ -
0.004	Reserves - Sick and Annual Leave	\$ -	\$ -	\$ -	\$ -
<b>TOTAL RESERVES</b>		\$ -	\$ -	\$ -	\$ -
<b>TOTAL BUDGETARY EXPENDITURES and BALANCES</b>		\$ 111,902.12	\$ 20,019.00	\$ -	\$ 131,921.12
<b>ENDING FUND BALANCE</b>		\$ -	\$ -	\$ -	\$ 131,921.12

APPROVED: \_\_\_\_\_ DATE \_\_\_\_\_  
Chairman of the Board, or Clerk of Circuit Court

APPROVED: \_\_\_\_\_ DATE \_\_\_\_\_  
FDACS Mosquito Control Program Representative



## COLUMBIA COUNTY BOARD OF COUNTY COMMISSIONERS AGENDA ITEM REQUEST FORM

The Board of County Commissioners meets the 1st and 3rd Thursday of each month in the Columbia County School Board Administrative Complex Auditorium, 372 West Duval Street, Lake City, Florida 32055. The first meeting of every month is at 9:30AM while the second meeting of every month takes place at 5:30PM. All agenda items are due in the Board's office one week prior to the meeting date.

Today's Date: 3/8/2024 Meeting Date: 3/21/2024

Department: Public Works

**1. Nature and purpose of agenda item:**

Utility permit from Comcast requesting to run a cable along SE County Road 252

**2. Recommended Motion/Action:**

Approve Utility permit from Comcast requesting to run a cable along SE County Road 252

**3. Fiscal impact on current budget.**

This item has no effect on the current budget.

**COLUMBIA COUNTY BOARD OF COUNTY COMISSIONERS  
UTILITY PERMIT**

Date: \_\_\_\_\_ Permit No. \_\_\_\_\_ County Road \_\_\_\_\_ Section No. \_\_\_\_\_

Permittee Southeast Utilities of Georgia OBO Comcast

Address 5934 Richard Street, Jacksonville, FL 32216 Telephone Number 407- 797 - 2997

Requesting permission from Columbia County, Florida, hereinafter called the County, to contract, operate and maintain Install 196' UG of .700 Coax along SE CR - 252 to improve service.

FR - JB1728376

FROM: 1013 SE COUNTY ROAD 252 TO: 125 SE PASTURE WAY

Submitted for the Utility Owner by: <u>Christy Feitlin - Permit Coordinator</u>	<u><i>Christy Feitlin</i></u>	<u>3/4/2024</u>
Typed Name & Title	Signature	Date

1. Permittee declares that prior to filing this application it has determined the location of all existing utilities, both aerial and underground and the accurate locations are shown on the plans attached hereto and made a part of this application. Proposed work is within corporate limits of Municipality: YES ( ) NO ( ). If YES: LAKE CITY ( ) FORT WHITE ( ). A letter of notification was mailed on 3/4/2024 to the following utility owners Clay Electric, Lake City Utilites, AT&T

2. The Columbia County Public Works Director shall be notified twenty-four (24) hours prior to starting work and again immediately upon completion of work. The Public Works Director is \_\_\_\_\_, located at 607 NW Quinten St Lake City, FL Telephone Number 386-758-1019. The PERMITTEE's employee responsible for Maintenance of Traffic is Tim Salyard Telephone Number 904-531-6985 (This name may be provided at the time of the 24 hour notice to starting work.)

3. This PERMITTEE shall commence actual construction in good faith within 30 days after issuance of permit, and shall be completed within 10 days after permitted work has begun. If the beginning date is more than 60 days from date of permit approval, then PERMITTEE must review the permit with the Columbia County Public Works Director to make sure no changes have occurred in the transportation facility that would affect the permitted construction.

4. The construction and maintenance of such utility shall not interfere with the property and rights of a prior PERMITTEE.

5. It is expressly stipulated that this permit is a license for permissive use only and that the placing of utilities upon public property pursuant to this permit shall not operate to create or vest any property right in said holder.

6. Pursuant to Section 337-403(1), Florida Statutes, whenever necessary for the construction, repair, improvement, maintenance, safe and efficient operation, alteration or relocation of all, or any portion of said transportation facility as determined by the Columbia County Public Works Director and/or County Engineer, any or all utilities and appurtenances authorized hereunder, shall be immediately removed from said transportation facility or reset or

relocated thereon as required by the Columbia County Public Works Director and/or County Engineer and at the expense of the PERMITTEE.

7. In case of non-compliance with the County's requirements in effect as of the approval date of this permit, this permit void and the facility will have to be brought into compliance or removed from the right of way at no cost to the County.

8. It is understood and agreed that the rights and privileges herein set out are granted only to the extent of the County's right, title and interest in the land to be entered upon and used by the PERMITTEE, and the PERMITTEE will, at all times, and to the extent permitted by law, assume all risk of and indemnify, defend, and save harmless Columbia County, Florida from any and all loss, damage, cost or expense arising in any manner on account of the exercise or attempted exercise by said PERMITTEE of the aforesaid right and privileges.

9. During construction, all safety regulations of the County shall be observed and the PERMITTEE must take measures, including pacing and the display of safety devices that may be necessary in order to safely conduct the public through the project area in accordance with the Federal Manual on Uniform Traffic Control Devices, as amended for highways.

10. Should the PERMITTEE be desirous of keeping its utilities in place and out of service, the PERMITTEE, by execution of this permit acknowledges its present and continuing ownership of its utilities located between 1013 SE COUNTY ROAD 252 and 125 SE PASTURE WAY within the County's right of way as set forth above. PERMITTEE, as its sole expense, shall promptly remove said out of service utilities whenever Columbia County Public Works Director and/or County Engineer determines said removal is in the public interest.

11. Special instructions: Minimum cover of thirty inches (30") will be required at all locations. Columbia County will not be financially responsible for any damage to facilities with less than thirty inches (30") cover. Cables shall not be located within driveway ditches.

12. Additional Stipulations: \_\_\_\_\_  
\_\_\_\_\_  
\_\_\_\_\_  
\_\_\_\_\_  
\_\_\_\_\_

It is understood and agreed that commencement by the PERMITTEE is acknowledgment and acceptance of the binding nature of these specialist instructions.

Submitted By: Christy Feitlin  
Permittee

Place Corporate Seal

*Christy Feitlin - PC*

Signature and Title

Attested

Utilities Permit  
Page three  
Revised: 8/17/00

Recommended for Approval:

Signature:                     142                    

Title:                     Asst County Manager                    

Date:                     02-06-24                    

Approval by Board of County Commissioners, Columbia County, Florida:

YES ( )                  NO ( )

Date Approved: \_\_\_\_\_

Chairman's Signature: \_\_\_\_\_



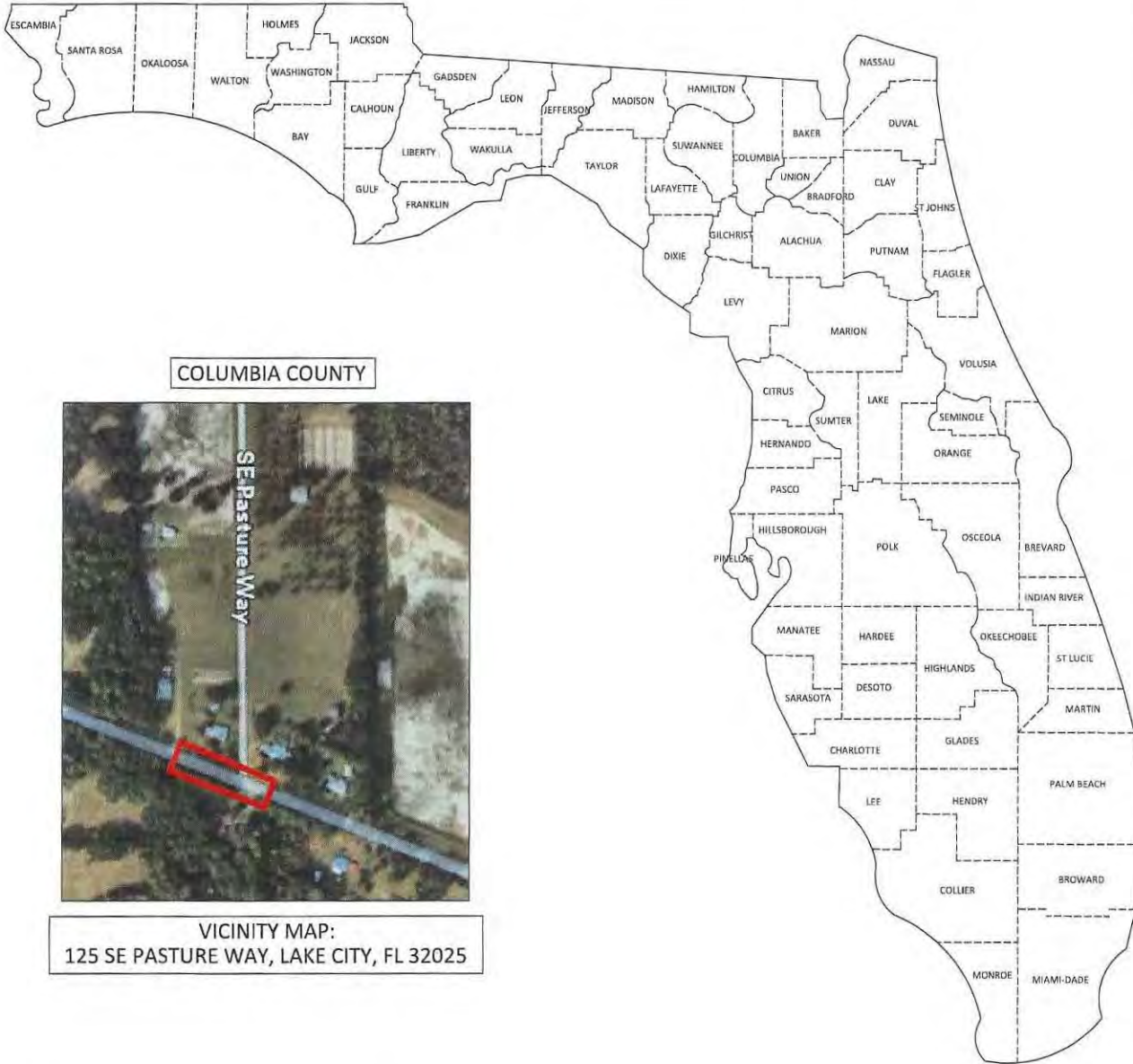

COLUMBIA COUNTY



VICINITY MAP:  
125 SE PASTURE WAY, LAKE CITY, FL 32025

COMCAST PERMIT REQUEST FOR LOCATION:  
125 SE PASTURE WAY, LAKE CITY, FL 32025

THESE PLANS WERE PREPARED UNDER THE  
RESPONSIBLE CHARGE OF COMCAST.

JB1728376

NO EXPECTED CONFLICTS  
WITH OTHER UTILITIES

LOCATION: 125 SE PASTURE WAY, LAKE CITY, FL 32025

TOTAL LENGTH OF JOB: 196' UG



JOB DESCRIPTION: CATV DIRECTIONAL BORE  
PLACEMENT

DRAWN BY: SS

DATE: 02/13/2023

SCALE: NTS

**GENERAL NOTES:**

ALL PROPOSED UNDERGROUND CATV WILL BE BURIED A MINIMUM OF 36" INCLUDING ROAD BORES AND DRIVEWAY BORES.

ALL PROPOSED UNDERGROUND CATV ROAD BORES WILL USE CITY APPROVED DIRECTIONAL BORE MACHINE, AS WELL AS COUNTY APPROVED CONDUIT.

ALL PROPOSED CATV ROAD BORES WILL EXTEND A MINIMUM OF 7' BEYOND THE EDGE OF PAVEMENT.

ALL PROPOSED CATV DRIVEWAY BORES WILL EXTEND A MINIMUM OF 6' BEYOND THE EDGE OF PAVEMENT.

ALL PROPOSED BORES WILL BE IN A (4'X4'X4') PIT AND WILL USE 2" HDPE CONDUIT AT 36" DEPTH USING A 5 1/4" DRILL HEAD.

ALL PROPOSED AERIAL CATV WILL BE 0.700" DIAMETER AND WILL BE LASHED TO 0.250" STEEL STRAND CABLE USING 0.125" STANDARD GALVANIZED LASHING WIRE.

ALL PROPOSED AERIAL CATV CROSSING ROADWAYS WILL HAVE A MINIMUM MID-SPAN HEIGHT OF 18'-0".

ALL PROPOSED AERIAL CATV CROSSING DRIVEWAYS WILL HAVE A MINIMUM MID-SPAN HEIGHT OF 16'-0".

LOCATES WILL BE REQUIRED IN ALL PROPOSED UNDERGROUND AREAS AT LEAST 48 HRS PRIOR TO CONSTRUCTION.

NOTIFICATIONS TO ALL UTILITIES INVOLVED WILL BE MADE PRIOR TO CONSTRUCTION.

ALL DISTRIBUTED AREA WITHIN THE RIGHT OF WAY WILL BE RESTORED TO ORIGINAL OR BETTER CONDITION BY GRADING AND RE-SODDING. SOD ALL AREAS DISTURBED BY CONSTRUCTION WITH BERMUDA SOD. "ALL CRACKED SIDEWALKS ARE TO BE REPLACED FROM JOINT TO JOINT WITHIN 7 DAYS OF WORK COMPLETION."

WORK OPERATIONS ARE TO BE MINDFUL NOT TO DAMAGE THE PAVER SIDEWALK WHEN POSITIONING EQUIPMENT. ANY DAMAGE INCLUDING TRACK MARKS WILL BE REPAIRED OR REPLACED BY THE CONTRACTOR.

**CONSTRUCTION NOTES:**

IN ORDER TO REDUCE THE DISRUPTION AND COST OF UTILITY DAMAGES OCCURRING IN THE RIGHT-OF-WAY AND EASEMENTS, THE PERMITTEE SHALL PREVENT DAMAGES TO EXISTING UTILITIES CAUSED BY THE WORK THROUGH FIELD VERIFICATION OF THE LOCATION OF THE EXISTING UTILITIES IN CASE OF OPEN EXCAVATION. VERIFICATION MAY BE PERFORMED DURING THE PERMITTEES WORK. IN THE CASE OF DIRECTIONAL DRILLING, VERIFICATION SHALL TAKE PLACE PRIOR TO MOBILIZATION OF THE DRILLING EQUIPMENT.

THE PERMITTEE SHALL VERIFY THE LOCATION OF THE EXISTING UTILITIES AS NEEDED TO AVOID CONTACT WITH DETECTION EQUIPMENT OR OTHER ACCEPTABLE MEANS, SUCH METHODS MAY INCLUDE BUT SHALL NOT BE LIMITED TO "SOFT DIG" EQUIPMENT AND GROUND PENETRATION RADAR (GPR). THE EXCAVATOR SHALL BE HELD LIABLE FOR DAMAGES CAUSED TO CITY'S/COUNTY'S/STATE INFRASTRUCTURE AND THE EXISTING FACILITIES OF THE OTHER UTILITY COMPANIES.

NO REAMER USED

THE FOLLOWING STANDARD PLANS ARE IN ACCORDANCE WITH  
THE FLORIDA DEPARTMENT OF TRANSPORTATION 2023-2024  
INDEX 102-602 AND APPLY TO:  
125 SE PASTURE WAY, LAKE CITY, FL 32025

- COMCAST AERIAL ROUTE
- COMCAST BORE ROUTE
- CABLE TV SPAN (EXIST)
- CABLE TV BORE (EXIST)
- FENCE
- FIBER OPTIC CABLE
- GAS PIPELINE
- OH POWER LINE
- UG POWER LINE
- PROPERTY LINE
- ROAD RIGHT-OF-WAY
- ROAD CENTERLINE
- EDGE OF PAVEMENT
- RAILROAD CENTERLINE
- SANITARY SEWER
- STORM SEWER
- OH TELEPHONE
- UG TELEPHONE
- BOTTOM BANK
- DRIVEWAY
- SIDEWALK
- TOP BANK
- UNKNOWN UG UTILITY
- WATER LINE

**LEGEND**

- MANHOLE (SANITARY SEWER)
- MANHOLE (STORM SEWER)
- CABLE TV PEDESTAL
- CABLE TV RISER
- UTILITY POLE
- FIRE HYDRANT
- WATER VALVE
- ELECTRIC PAD
- RAILROAD CROSSING SIGN
- RAILROAD CROSSING SIGNAL
- INLET
- CATCH BASIN
- WATER VAULT
- TELEPHONE PEDESTAL
- ELECTRIC VAULT
- BORE PIT
- CULVERT
- WATER MAIN / METER
- HAND HOLE
- UTILITY VAULT
- CATV VAULT
- CATV VAULT
- GAS VALVE

NO BACKREAMER USED

NO EXPECTED CONFLICTS  
WITH OTHER UTILITIES

COMCAST PERMIT REQUEST FOR LOCATION:  
125 SE PASTURE WAY, LAKE CITY, FL 32025

LOCATION: 125 SE PASTURE WAY, LAKE CITY, FL 32025

TOTAL LENGTH OF JOB: 196' UG



JOB DESCRIPTION: CATV DIRECTIONAL BORE  
PLACEMENT

DRAWN BY: SS

DATE: 02/13/2023

SCALE: NTS

2 OF 4

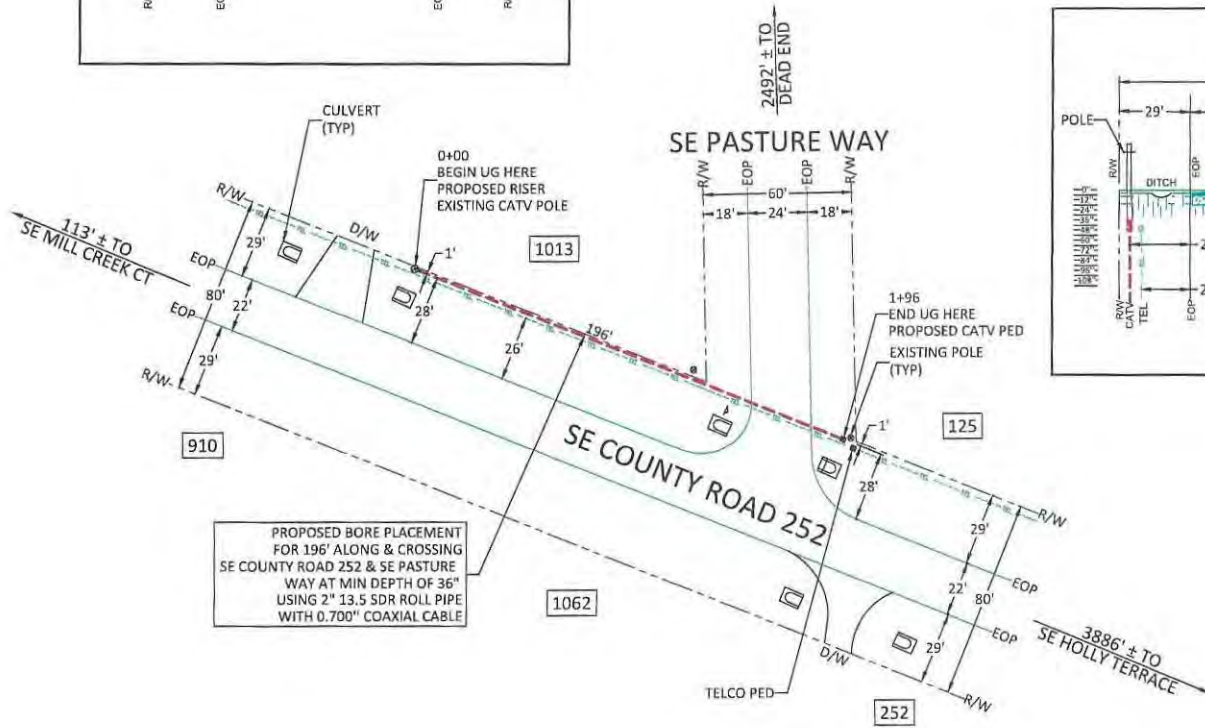
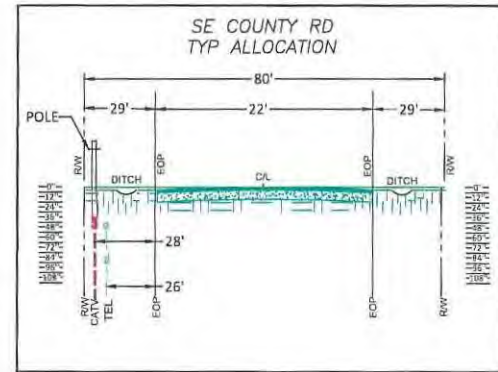
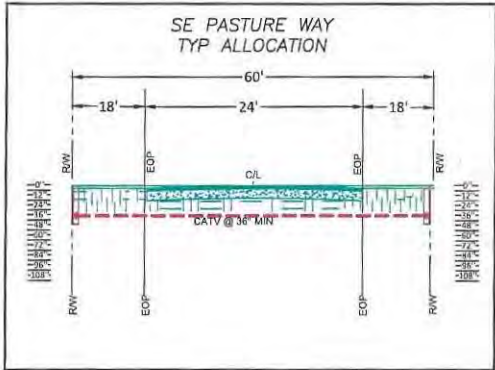
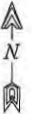

PROPOSED BORE PLACEMENT FOR 196' ALONG & CROSSING SE COUNTY ROAD 252 & SE PASTURE WAY AT MIN DEPTH OF 36" USING 2" 13.5 SDR ROLL PIPE WITH 0.700" COAXIAL CABLE





NO BACKREAMER USED  
NO EXPECTED CONFLICTS WITH OTHER UTILITIES

LOCATION: 125 SE PASTURE WAY, LAKE CITY, FL 32025	
TOTAL LENGTH OF JOB: 196' UG	
 <b>COMCAST</b>	
JOB DESCRIPTION: CATV DIRECTIONAL BORE PLACEMENT	
DRAWN BY: SS	3 OF 4
DATE: 02/13/2023	
SCALE: NTS	

**NOTE:**

1. This Index applies to Two-Lane, Two-Way and Multilane Roadways, including Medians of divided roadways with work on the shoulder.
2.  $L$  = Taper Length  
 $T$  = Work Zone Sign Spacing  
 $B$  = Buffer Length  
 See Index 102-600 for "L", "T", "B", and channelizing device spacing values.
3. Where work activities are between 2' and 15' from the edge of traveled way, the Engineer may omit signs and channelizing devices for work operations 60 minutes or less.
4. When four or more work vehicles enter the through traffic lanes in a one hour period including establishing and terminating the work area, use a flagger or lane closure to accommodate work vehicle ingress and egress.
5. For work less than 2' from the traveled way and work zone speed is greater than 45 MPH, use a lane closure.
6. The "Speeding Fines Doubled When Workers Present" signs (W07-3-06) and "End Road Work" signs (W20-2) along with the associated work zone sign spacing distances may be omitted when the work operation is in place for 24 hours or less.
7. Temporary pavement markings may be omitted when the work operation is in place for 3 days or less.
8. Only "Shoulder Closed" signs (W21-5a) along with associated work zone sign spacing distances for work on the shoulder.
9. When there is no paved shoulder, the "Worker" sign (W21-1) may be used instead of the "Shoulder Closed" sign (W21-5a).

**SYMBOLS:**

-  Work Area
-  Channelizing Device (See Index 102-600)
-  Work Zone Sign
-  Lane Configuration and Direction of Traffic

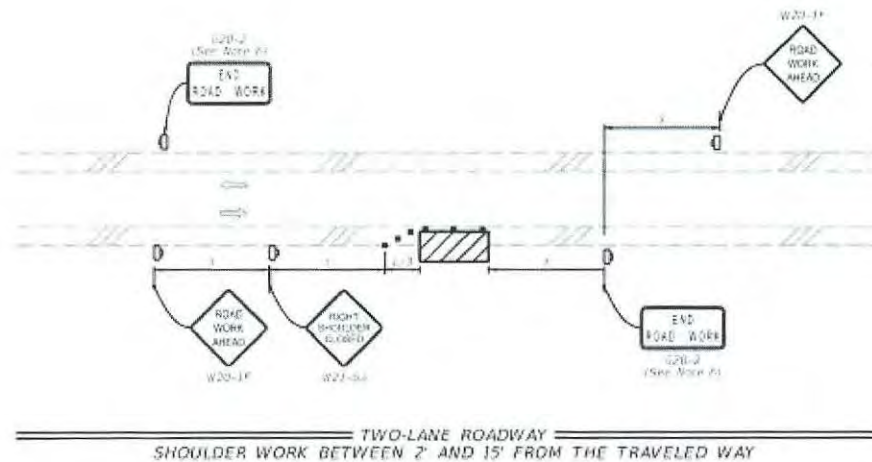
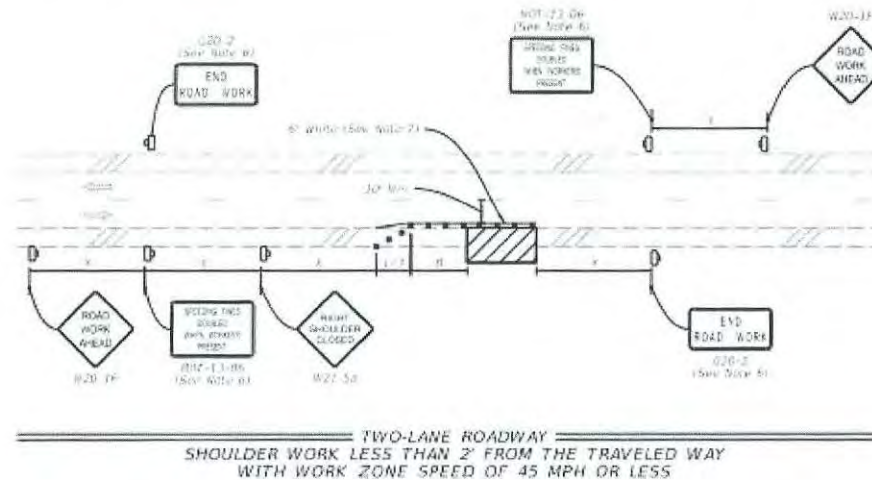

LAST REVISION	DESCRIPTION:
11/01/21	

REVISION	DESCRIPTION:

**FY 2023-24**  
**STANDARD PLANS**

**TWO-LANE AND MULTILANE, WORK ON SHOULDER**

INDEX	SHEET
102-602	4 OF 4



## COLUMBIA COUNTY BOARD OF COUNTY COMMISSIONERS AGENDA ITEM REQUEST FORM

The Board of County Commissioners meets the 1st and 3rd Thursday of each month in the Columbia County School Board Administrative Complex Auditorium, 372 West Duval Street, Lake City, Florida 32055. The first meeting of every month is at 9:30AM while the second meeting of every month takes place at 5:30PM. All agenda items are due in the Board's office one week prior to the meeting date.

Today's Date: 3/8/2024 Meeting Date: 3/21/2024

Department: Public Works

**1. Nature and purpose of agenda item:**

Utility permit from Duke Energy requesting to replace a pole on SW Holsein Ave.

**2. Recommended Motion/Action:**

Approve Utility permit from Duke Energy requesting to replace a pole on SW Holsein Ave.

**3. Fiscal impact on current budget.**

This item has no effect on the current budget.

COLUMBIA COUNTY BOARD OF COUNTY COMISSIONERS  
UTILITY PERMIT

Date: 02/06/2024 Permit No. \_\_\_\_\_ County Road SOUTHWEST HOLSEIN AVENUE Section No. 33

Permittee DUKE ENERGY

Address 4427 PET LN STE 101 LUTZ, FL, 33559 Telephone Number 813-909-6043

Requesting permission from Columbia County, Florida, hereinafter called the County, to contract, operate and maintain REPLACE 40/2 WOOD POLE WITH 50/2 WOOD POLE, REPLACE SPAN GUY

FROM: 04/09/2024 TO: 05/09/2024

Submitted for the Utility Owner by:	<u>NATALIE OGDEN - PERMIT MANAGER</u>	<u><i>Natalie Ogden</i></u>	<u>02/06/2024</u>
	Typed Name & Title	Signature	Date

1. Permittee declares that prior to filing this application it has determined the location of all existing utilities, both aerial and underground and the accurate locations are shown on the plans attached hereto and made a part of this application. Proposed work is within corporate limits of Municipality: YES (  ) NO (  ). If YES: LAKE CITY (  ) FORT WHITE (  ). A letter of notification was mailed on \_\_\_\_\_ to the following utility owners DUKE ENERGY

2. The Columbia County Public Works Director shall be notified twenty-four (24) hours prior to starting work and again immediately upon completion of work. The Public Works Director is KEVIN IRBY, located at 607 NW QUINTEN ST LAKE CITY, FL 32055 Telephone Number 386-758-2148. The PERMITTEE's employee responsible for Maintenance of Traffic is \_\_\_\_\_ Telephone Number \_\_\_\_\_ (This name may be provided at the time of the 24 hour notice to starting work.)

3. This PERMITTEE shall commence actual construction in good faith within \_\_\_\_\_ days after issuance of permit, and shall be completed within \_\_\_\_\_ days after permitted work has begun. If the beginning date is more than 60 days from date of permit approval, then PERMITTEE must review the permit with the Columbia County Public Works Director to make sure no changes have occurred in the transportation facility that would affect the permitted construction.

4. The construction and maintenance of such utility shall not interfere with the property and rights of a prior PERMITTEE.

5. It is expressly stipulated that this permit is a license for permissive use only and that the placing of utilities upon public property pursuant to this permit shall not operate to create or vest any property right in said holder.

6. Pursuant to Section 337-403(1), Florida Statutes, whenever necessary for the construction, repair, improvement, maintenance, safe and efficient operation, alteration or relocation of all, or any portion of said transportation facility as determined by the Columbia County Public Works Director and/or County Engineer, any or all utilities and appurtenances authorized hereunder, shall be immediately removed from said transportation facility or reset or

relocated thereon as required by the Columbia County Public Works Director and/or County Engineer and at the expense of the PERMITTEE.

7. In case of non-compliance with the County's requirements in effect as of the approval date of this permit, this permit void and the facility will have to be brought into compliance or removed from the right of way at no cost to the County.

8. It is understood and agreed that the rights and privileges herein set out are granted only to the extent of the County's right, title and interest in the land to be entered upon and used by the PERMITTEE, and the PERMITTEE will, at all times, and to the extent permitted by law, assume all risk of and indemnify, defend, and save harmless Columbia County, Florida from any and all loss, damage, cost or expense arising in any manner on account of the exercise or attempted exercise by said PERMITTEE of the aforesaid right and privileges.

9. During construction, all safety regulations of the County shall be observed and the PERMITTEE must take measures, including pacing and the display of safety devices that may be necessary in order to safely conduct the public through the project area in accordance with the Federal Manual on Uniform Traffic Control Devices, as amended for highways.

10. Should the PERMITTEE be desirous of keeping its utilities in place and out of service, the PERMITTEE, by execution of this permit acknowledges its present and continuing ownership of its utilities located between SOUTHWEST US HIGHWAY 27 and SOUTHWEST WELL STREET within the County's right of way as set forth above. PERMITTEE, as its sole expense, shall promptly remove said out of service utilities whenever Columbia County Public Works Director and/or County Engineer determines said removal is in the public interest.

11. Special instructions: Minimum cover of thirty inches (30") will be required at all locations. Columbia County will not be financially responsible for any damage to facilities with less than thirty inches (30") cover. Cables shall not be located within driveway ditches.

12. Additional Stipulations: \_\_\_\_\_  
\_\_\_\_\_  
\_\_\_\_\_  
\_\_\_\_\_  
\_\_\_\_\_

It is understood and agreed that commencement by the PERMITTEE is acknowledgment and acceptance of the binding nature of these specialist instructions.

Submitted By: NATALIE OGDEN  
Permittee

Place Corporate Seal

Natalie Ogden PERMIT MANAGER  
Signature and Title

\_\_\_\_\_  
Attested

Utilities Permit  
Page three  
Revised: 8/17/00

Recommended for Approval:

Signature:                     143                    

Title:                     ASS COUNTY MANAGER                    

Date:                     030624                    

Approval by Board of County Commissioners, Columbia County, Florida:

YES ( )      NO ( )

Date Approved: \_\_\_\_\_

Chairman's Signature: \_\_\_\_\_





USP:  
 USP: FUSE: 562129-1 (80 KS)  
 USP: RECLOSER: 8145629 (800 VPST)  
 USP: CIRCUIT BREAKER: A20 (FORT WHITE 230KV 0111)



Safety Reminders / Adverse Conditions

?:  
 ?:  
 ? : LOW AVIAN RISK AREA  
 ? : OUTAGE REQUIRED



911 ADDRESS:  
 208 SW CULLEN AVE,  
 FORT WHITE, FL 32038

REMEMBER: Work zone area conditions may have changed for this job! Everyone is responsible for verifying the above safety information is correct prior to any work being performed each day.

P1  
 FIELD TAG - 128617  
 RETAG - 5625138  
 SPEC# 06.08-344  
 RFS - 40/2  
 I - 50/2  
 T - 100 KVA (B) 120/240V  
 T - 50 KVA (C) 120/240V  
 R/I - SGUY ATTACH  
 T - ST LGT



SW HOLSTEIN AVE

SW CULLEN AVE



DUKE ENERGY  
 ELIZABETH O'HARA  
 (352) 694-8875  
 ENGINEERING PARTNER  
 KCI TECHNOLOGIES  
 WILLIAM MALDONADO  
 (813) 605-7942

Work Order Number	52367597
Customer/Contact	
Contact Phone	
Job Site Address	208 SW CULLEN AV
City	FORT WHITE
County	COLUMBIA
State, Zip	FL, 32038
Designer	ISMAEL SANCHEZ
Designer Phone	(813) 386-2920
Circuit ID	A20
Primary Voltage	12.47/7.2 KV
Permit Required	Yes No
Permit Type/No.	
Permit Type/No. 2	
Permit Type/No. 3	
Revision Data	

SCOPE OF WORK:

- AT THE P1 LOCATION REPLACE 40/2 WOOD POLE WITH 50/2 WOOD POLE, TRANSFER 150KV (BC) 120/240V OPEN DELTA/OPEN DELTA TRANSFORMER BANK, TRANSFER SPAN GUY

CONSTRUCTION NOTES:

- TARGET IS ACCESSIBLE, LOCATED NORTHWEST OF 911 ADDRESS  
 - POLE IS YELLOW TAGGED  
 - NEW POLE TO BE INSTALL IN THE RIGHT OF WAY, TO THE NORTH SIDE OF THE EXISTING POLE, AS CLOSE AS THE FIELD CONDITION ALLOW.

P1 - GPS: 29.923676, -82.715446

**CROSS SECTION**

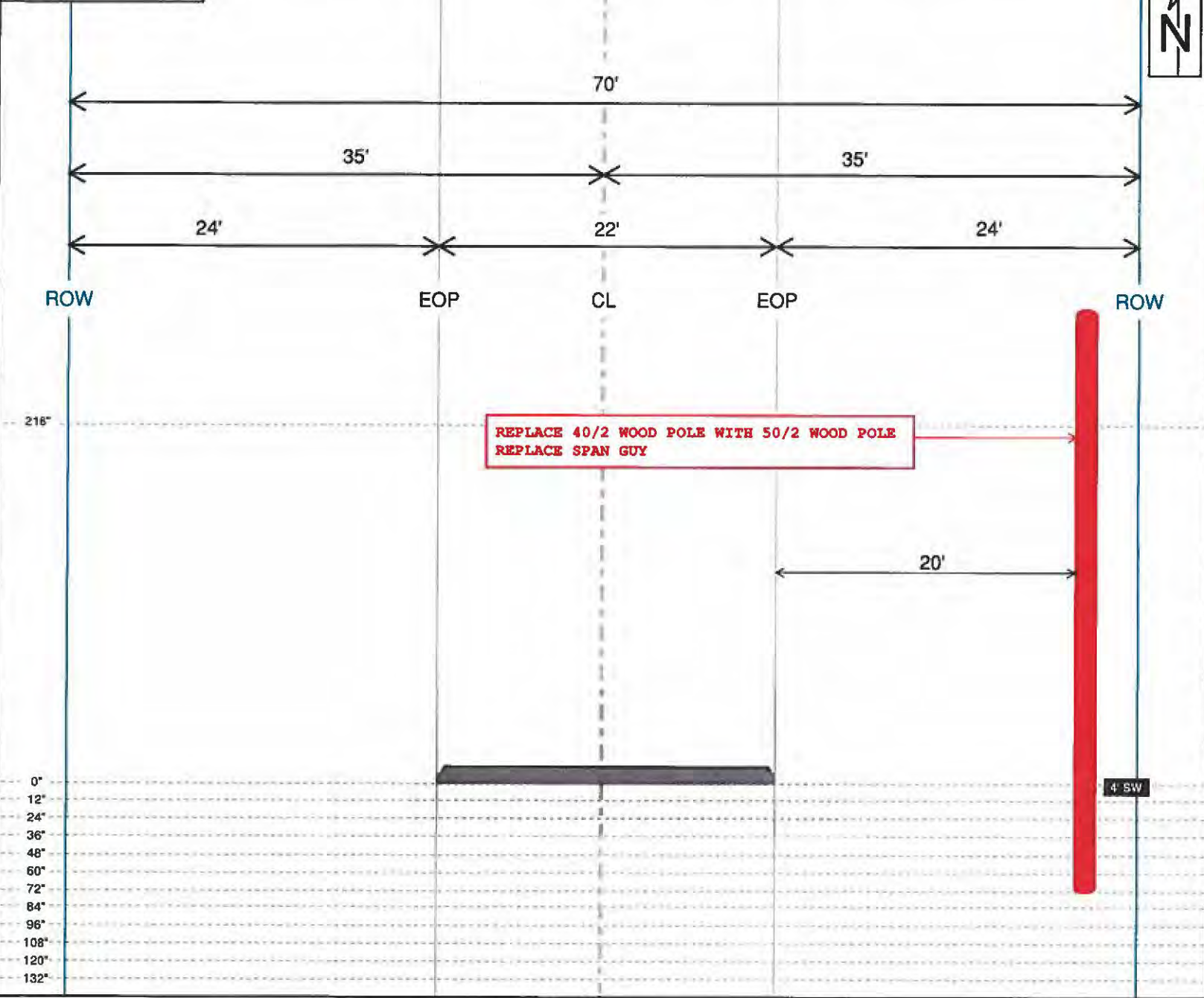

**Scope of Work**

TYPICAL CROSS SECTION FOR:  
OVERHEAD AND / OR  
UNDERGROUND  
PROPOSED FACILITIES

**LEGEND**

- G GAS
- E ELECTRIC
- C TELECOM
- F FIBER
- W WATER
- R RECLAIMED WATER
- S SEWER
- D STORM DRAIN
- MANHOLE
- FIRE HYDRANT
- WATER VALVE
- SILT SKIRT
- TREE TRIM

**EXISTING PROPOSED**

- ⊗ POLE
- ⊗ POLE
- △ TRANSFORMER
- △ TRANSFORMER
- P PEDESTAL
- P PEDESTAL
- PB PULLBOX
- PB PULLBOX
- VAULT VAULT
- VAULT VAULT

**CROSS SECTION PG/LOCATION**



CIRCUIT ID: A20

PRIMARY VOLTAGE: 12.47/7.2 KV

WORK ORDER #: 52367597

PROJECT SITE ADDRESS:

**SOUTHWEST HOLSTEIN AVENUE  
FACING NORTH**

SECTION:	TWP:	RANGE:
33	06S	16E

PERMIT LEAD: KATHY MADER-BROWN

PERMIT ASSIST: DAVID MASSELINK/SM

DATE: 02/06/2024

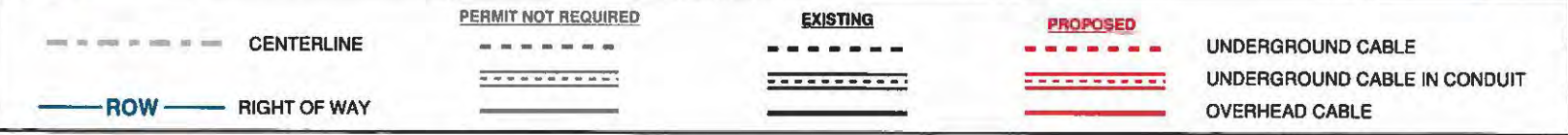

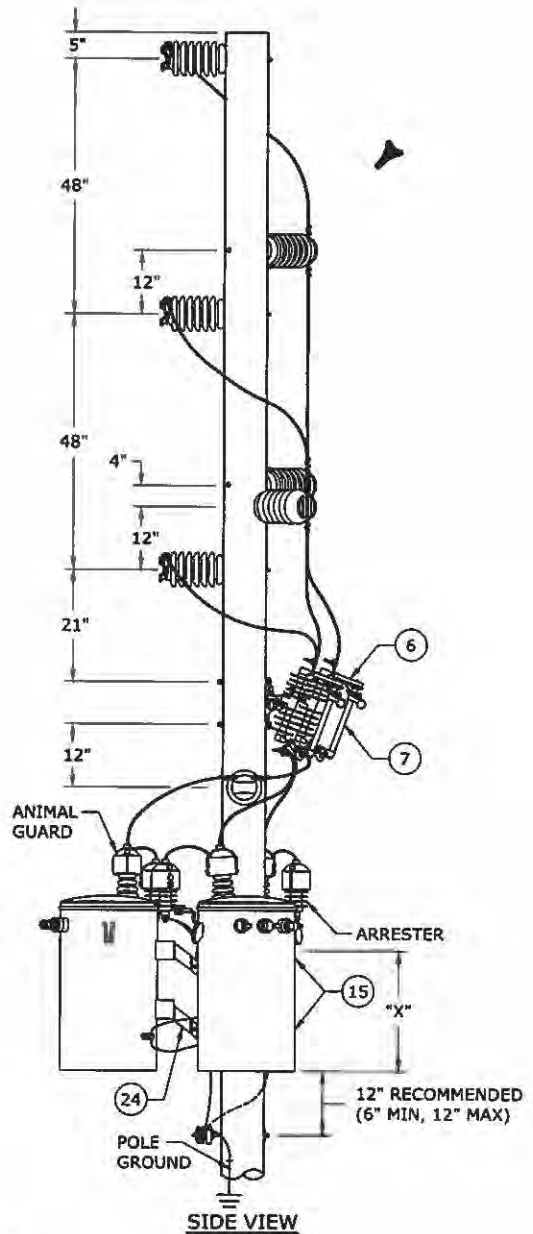
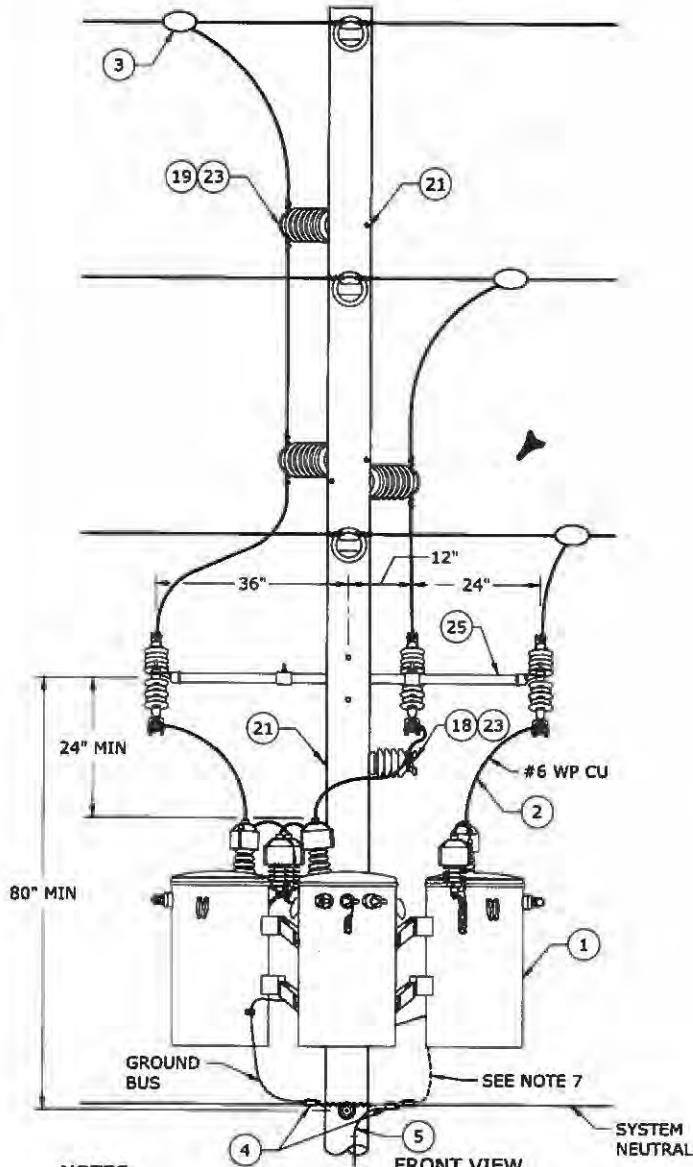
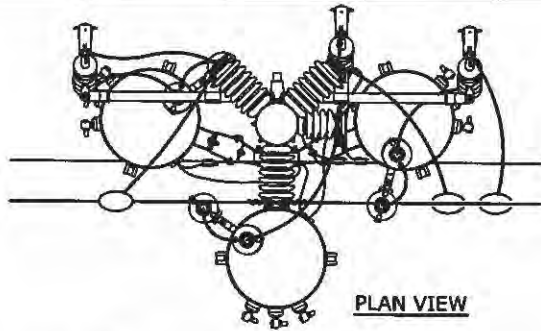

**NOTES:**

1. SEE DWGS. 06.00-104A AND 06.00-104B FOR "X" DIMENSION.
2. SEE SECTION 10 FOR PROPER POWER ZONE.
3. ALL PRIMARY LEAD WIRE SHALL BE INSULATED.
4. SEE DWGS. 02.03-102 AND 02.03-110 FOR GROUNDING AND BONDING DETAILS.
5. IF CONDITIONS REQUIRE DEVIATION FROM THIS STANDARD, SEE DWG. 06.00-120 FOR GENERAL EQUIPMENT MOUNTING GUIDELINES.
6. SEE DWG. 06.08-388 FOR BILL OF MATERIALS.
7. FOR FLOATING WYE DELIVERIES, COMPLETE THE TRANSFORMER GROUND LOOP BACK TO SYSTEM NEUTRAL.

3				
2	7/28/21	MORGAN	BURLISON	GRAHAM
1	4/7/20	MORGAN	BURLISON	GRAHAM
0	10/31/19	MORGAN	BURLISON	ADCOCK
REVISED	BY	CHK'D	APPR.	

**THREE-PHASE VERTICAL TANGENT CONSTRUCTION  
GROUNDED WYE PRIMARY BANKING CONNECTION**



DEC	DEM	DEP	DEF
X	X	X	X

**06.08-344**

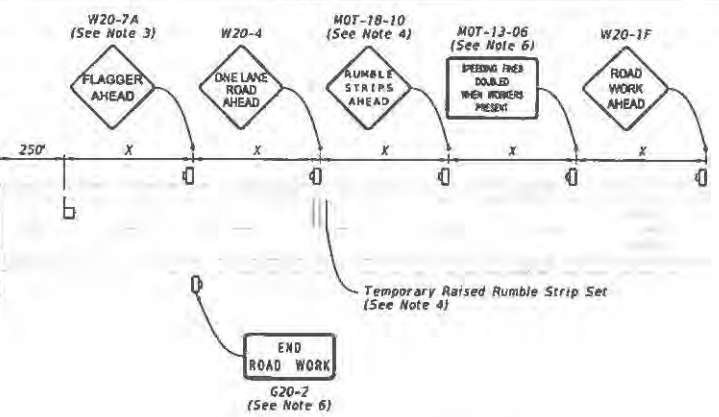
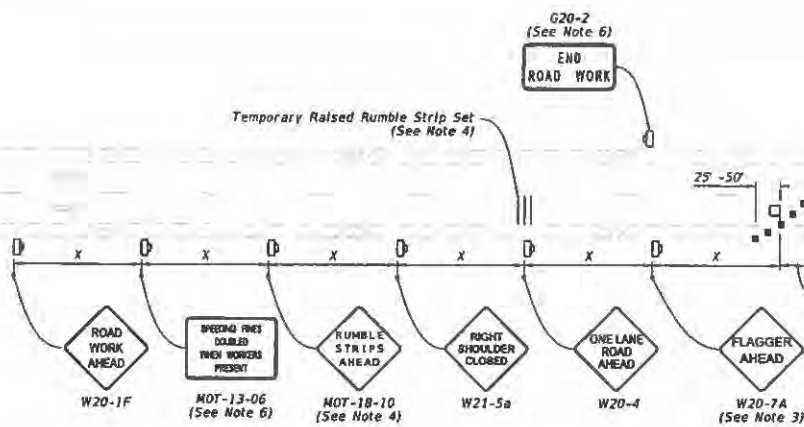

**NOTES:**

- This Index applies to Two-Lane, Two-Way Roadways with work within the traveled way.
- L = Taper Length  
B = Buffer Length  
X = Work Zone Sign Spacing  
See Index 102-600 for "L", "B", "X" and channelizing device spacing values.
- Optionally, use "Flagger Ahead" sign with symbol (W20-7) instead of "Flagger Ahead" sign with text (W20-7A).
- Use temporary raised rumble strips when the existing posted speed is 55 mph or greater and the work duration is greater than 60 minutes. If temporary raised rumble strips are not used, omit "Rumble Strips Ahead" signs (MOT-18-10) and associated work zone sign spacing.
- Additional one-way control may be provided by the following means:
  - Flag-carrying vehicle
  - Official vehicle
  - Pilot vehicles
  - Traffic signals

- The "Speeding Fines Doubled When Workers Present" signs (MOT-13-06) and "End Road Work" signs (G20-2), along with associated work zone sign spacing, may be omitted when the work operation will be in place for 24 hours or less.
- Automated Flagger Assistance Devices (AFADs) may be used in accordance with Specification Sections 102, 990 and the APL vendor drawings.
- Railroad Crossings.
  - If an active railroad crossing is located closer to the Work Area than the queue length plus 300 feet, extend the Buffer Space as shown on Sheet 2.
  - If the queuing of vehicles across an active railroad crossing cannot be avoided, provide a uniformed traffic control officer or flagger at the highway-rail grade crossing to prevent vehicles from stopping within the highway-rail grade crossing, even if automatic train warning devices are in place.

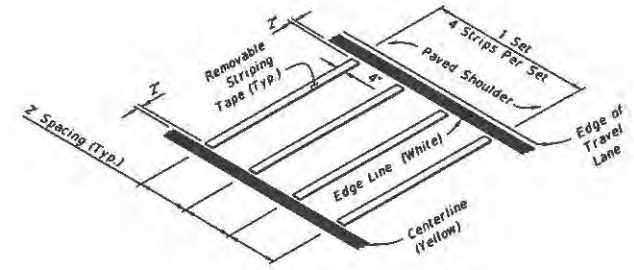

**OPTION - 1  
REMOVABLE STRIPING TYPE**

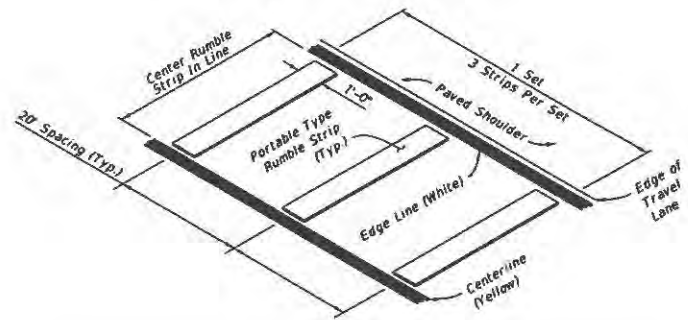

**OPTION - 2  
PORTABLE TYPE**

**RUMBLE STRIP SETS**

**SYMBOLS:**

- Work Area
- Channelizing Device (See Index 102-600)
- Work Zone Sign
- Flagger
- Lane Identification and Direction of Traffic

LAST REVISION 11/01/21	DESCRIPTION:	<b>FY 2023-24 STANDARD PLANS</b>	<b>TWO-LANE, TWO-WAY WORK WITHIN THE TRAVEL WAY</b>	INDEX 102-603	SHEET 1 of 2
---------------------------	--------------	--------------------------------------	---	------------------	-----------------

10/6/2022 1:24:30 PM

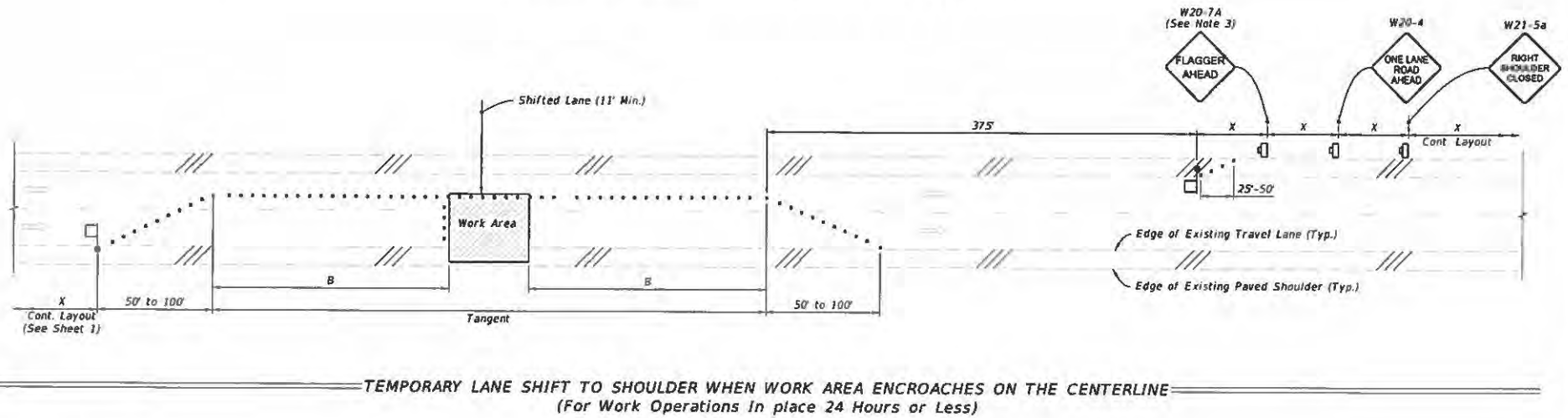
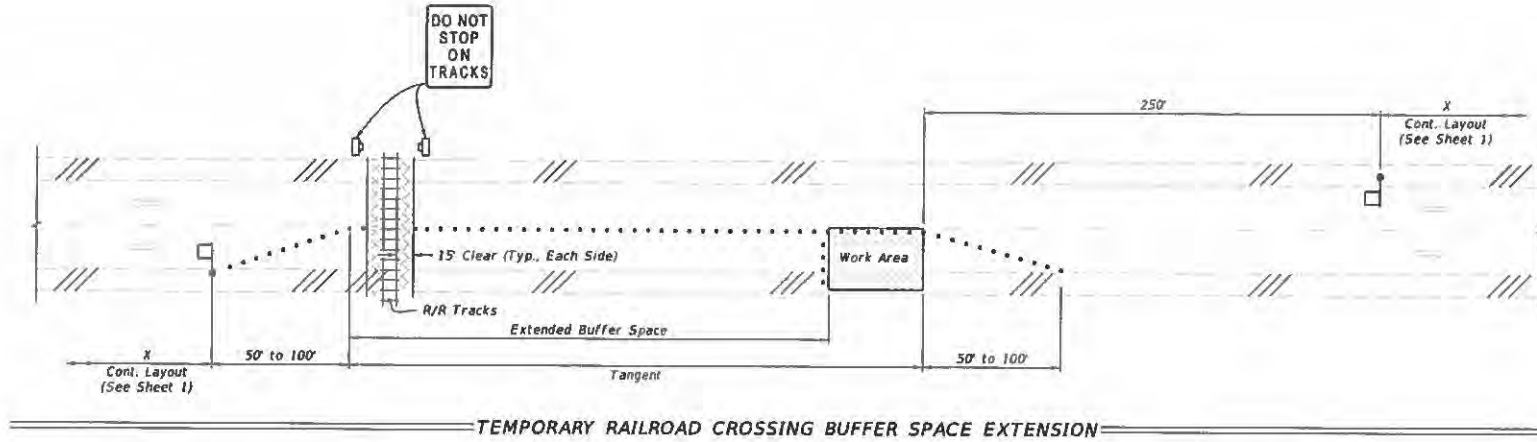

**SYMBOLS:**

- Work Area
- Channelizing Device (See Index 102-600)
- Work Zone Sign
- Flagger
- Lane Identification and Direction of Traffic







**SPECIAL CONDITIONS**

LAST REVISION 11/01/21	DESCRIPTION:	<b>FY 2023-24 STANDARD PLANS</b>	<b>TWO-LANE, TWO-WAY WORK WITHIN THE TRAVEL WAY</b>	INDEX 102-603	SHEET 2 of 2
---------------------------	--------------	--------------------------------------	---	------------------	-----------------

**GENERAL NOTES:**

1. L = Taper Length  
B = Buffer Length  
X = Work Zone Sign Distance  
See Index 102-600 for "L", "B", "X", and channelizing device spacing values.
2. If vehicles in a parking zone block the line of sight to TCZ signs, locate and post mount signs in accordance with Index 700-101.
3. Use temporary "STOP" sign (R1-1) where the existing stop bar is more than 30' from the taper, remove or cover existing sign.
4. The "Speeding Fines Doubled When Workers Present" sign (MOT-13-06) and "End Road Work" Sign (G20-2), along with associated Work Zone Sign Distances, may be omitted when the work operation will be in place for 24 hours or less. Additionally, arrow boards may be omitted when the work operation will be in place for 60 minutes or less and the speed limit is 45 mph or less.
5. If the work area extends across a crosswalk, close the crosswalk in accordance with Index 102-660.
6. Dual signs are required for divided roadways.

**SYMBOLS:**

-  Work Area
-  Channelizing Device (See Index 102-600)
-  Work Zone Sign
-  Type III Barricade
-  Arrow Board
-  Stop Bar
-  Lane Identification and Direction of Traffic

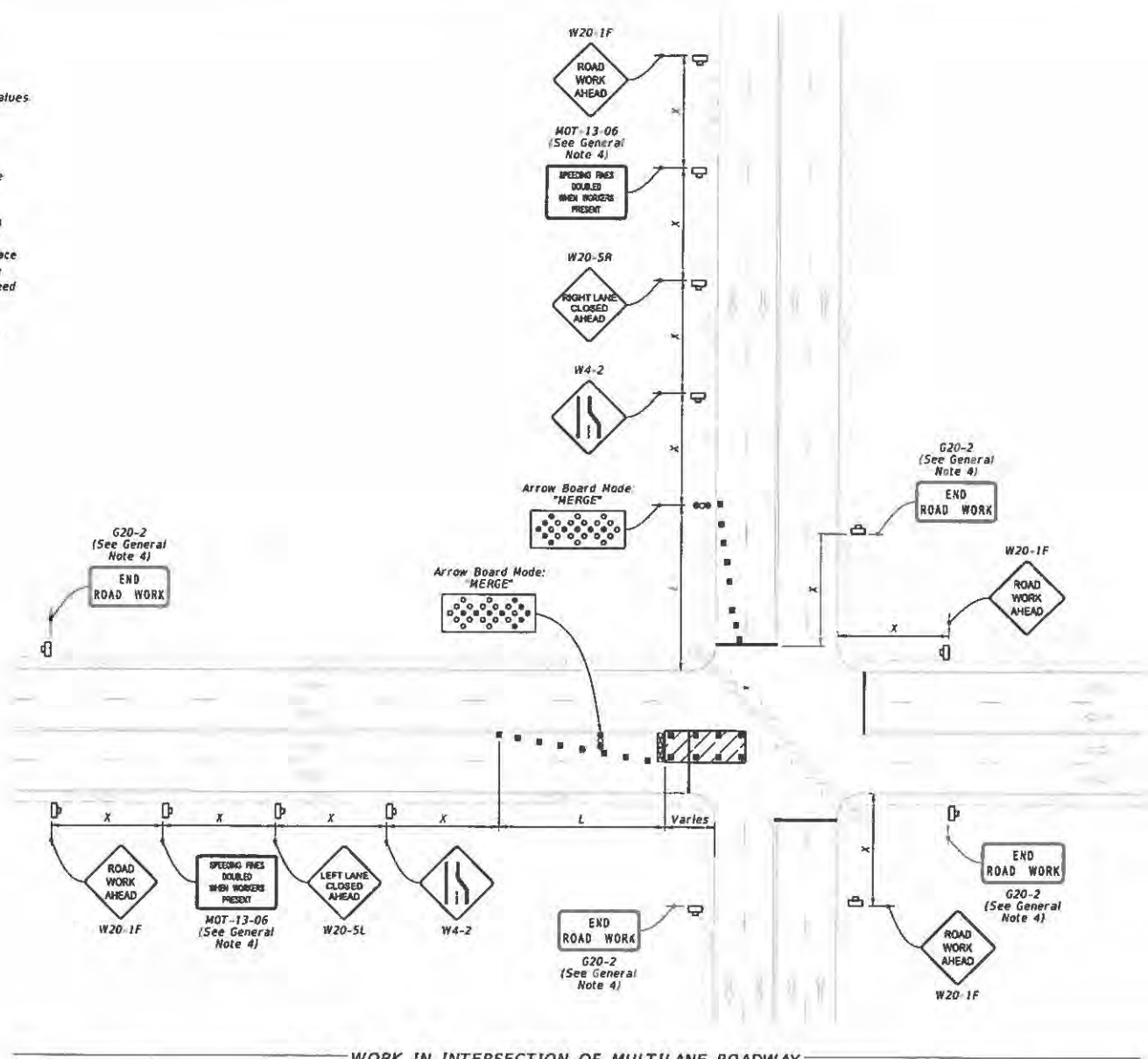

WORK IN INTERSECTION OF MULTILANE ROADWAY

10/17/2022 2:45:52 PM

LAST REVISION 11/01/22	REVISION	DESCRIPTION:	 FY 2023-24 STANDARD PLANS	<b>MULTILANE ROADWAY, INTERSECTION WORK</b>	INDEX 102-615	SHEET 1 of 5
---------------------------	----------	--------------	--	---	------------------	-----------------

**NOTE:**

Confine work operations to the following lane or lane combinations:

- a. Outside travel lane
- b. Outside auxiliary lane
- c. Outside travel lane and adjoining auxiliary lane
- d. Inside travel lane
- e. Inside auxiliary lane
- f. Inside travel lane and adjoining auxiliary lane

If the work area is confined to an auxiliary lane, the work area must be barricaded. Replace the RIGHT (LEFT) LANE CLOSED AHEAD signs with ROAD WORK AHEAD signs, and omit the merge symbol signs and arrow board.

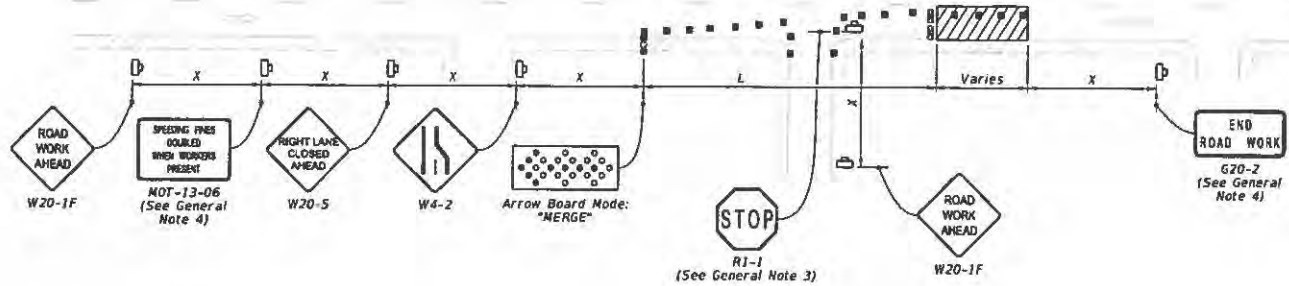

RIGHT LANE CLOSED ON FAR SIDE OF MINOR SIDE STREET

**SYMBOLS:**

- Work Area
- Channelizing Device (See Index 102-600)
- Work Zone Sign
- Type III Barricade
- Arrow Board
- Stop Bar
- Lane Identification and Direction of Traffic

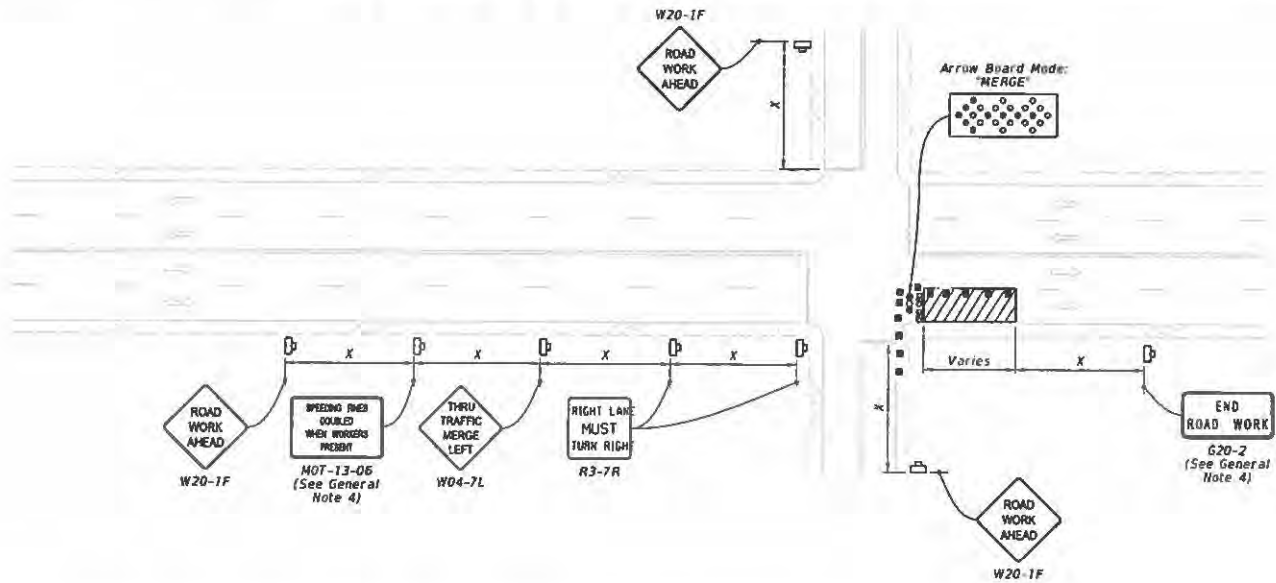

RIGHT LANE CLOSED ON FAR SIDE OF INTERSECTION WITH SIGNIFICANT RIGHT TURNING MOVEMENTS

11/1/2022 3:29:11 PM

LAST REVISION	REVISION	DESCRIPTION:
11/01/22		



FY 2023-24  
STANDARD PLANS

MULTILANE ROADWAY, INTERSECTION WORK

INDEX  
102-615

SHEET  
2 of 5

**NOTES:**

1. Confine work operations to the following lane or lane combinations:

- a. Outside travel lane
- b. Outside auxiliary lane
- c. Outside travel lane and adjoining auxiliary lane
- d. Inside travel lane
- e. Inside auxiliary lane
- f. Inside travel lane and adjoining auxiliary lane

If the work area is confined to an auxiliary lane, the work area must be barricaded. Replace the RIGHT (LEFT) LANE CLOSED AHEAD signs with ROAD WORK AHEAD signs, and omit the merge symbol signs and arrow board.

2. Provide sufficient Queue Length so that left-turning vehicles do not block through lanes.

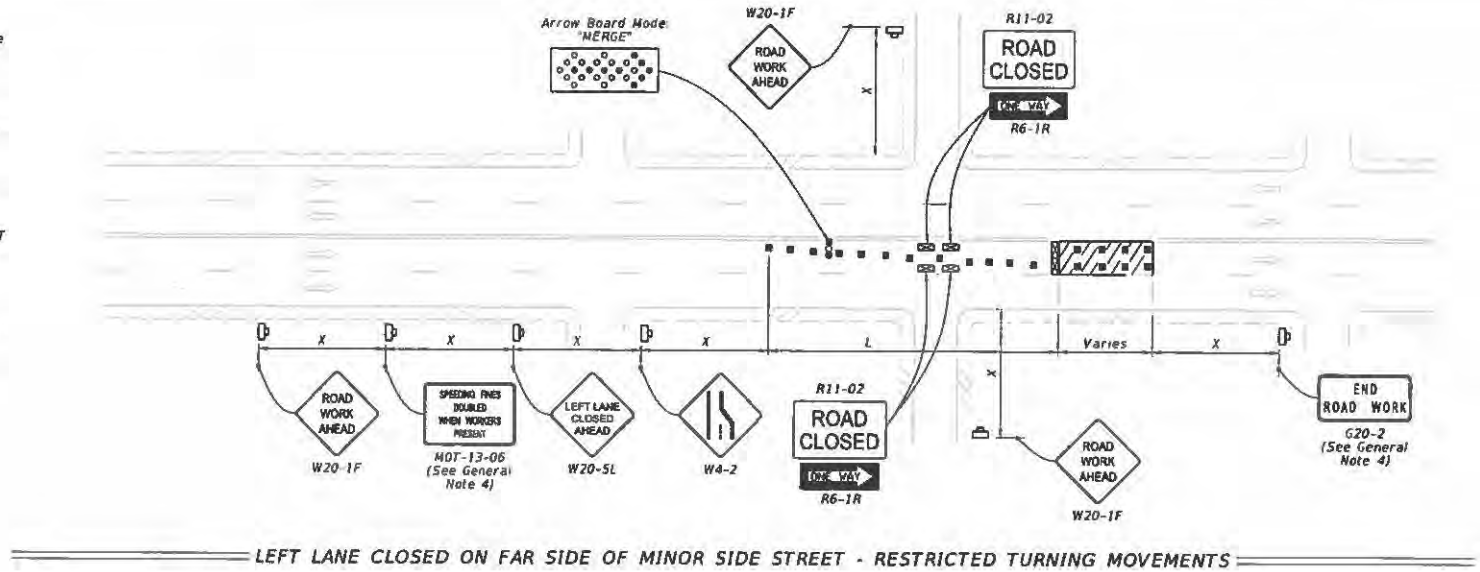

LEFT LANE CLOSED ON FAR SIDE OF MINOR SIDE STREET - RESTRICTED TURNING MOVEMENTS

**SYMBOLS:**

- Work Area
- Channelizing Device (See Index 102-600)
- Work Zone Sign
- Type III Barricade
- Arrow Board
- Stop Bar
- Lane Identification and Direction of Traffic

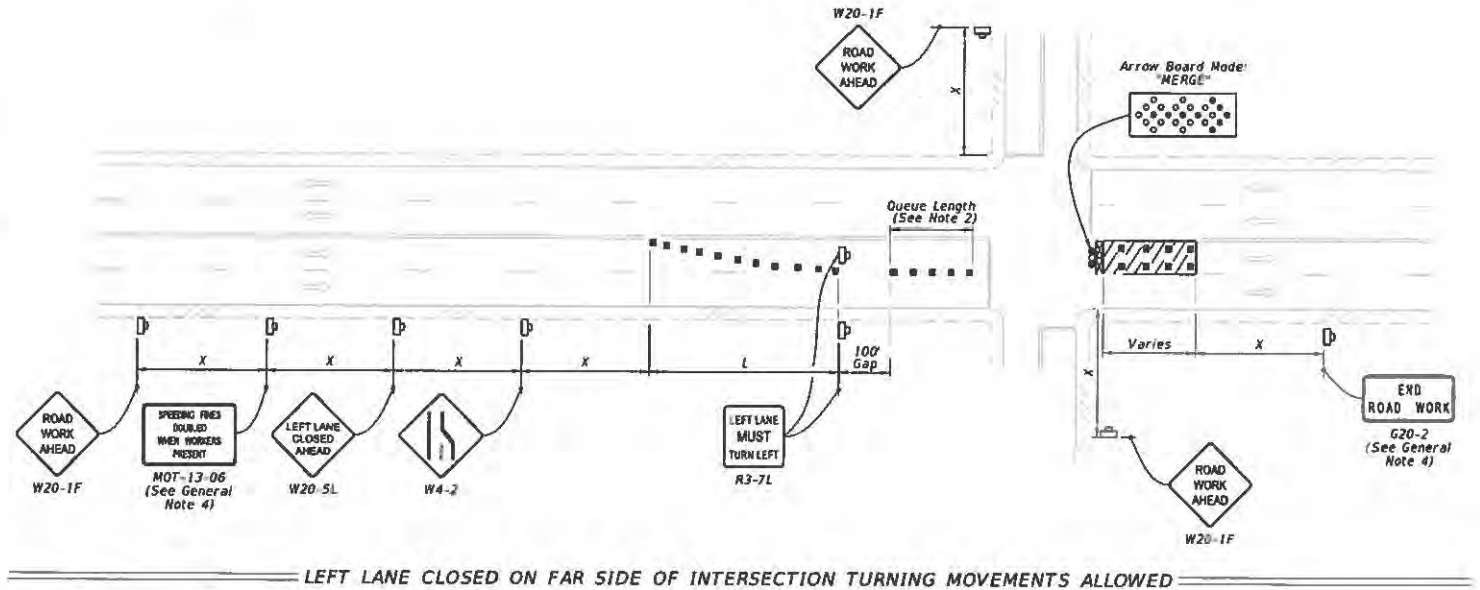

LEFT LANE CLOSED ON FAR SIDE OF INTERSECTION TURNING MOVEMENTS ALLOWED

11/01/2022 9:03:16 AM

LAST REVISION 11/01/22	REVISION	DESCRIPTION:	 FY 2023-24 STANDARD PLANS	MULTILANE ROADWAY, INTERSECTION WORK	INDEX 102-615	SHEET 3 of 5
---------------------------	----------	--------------	----------------------------------	--------------------------------------	------------------	-----------------



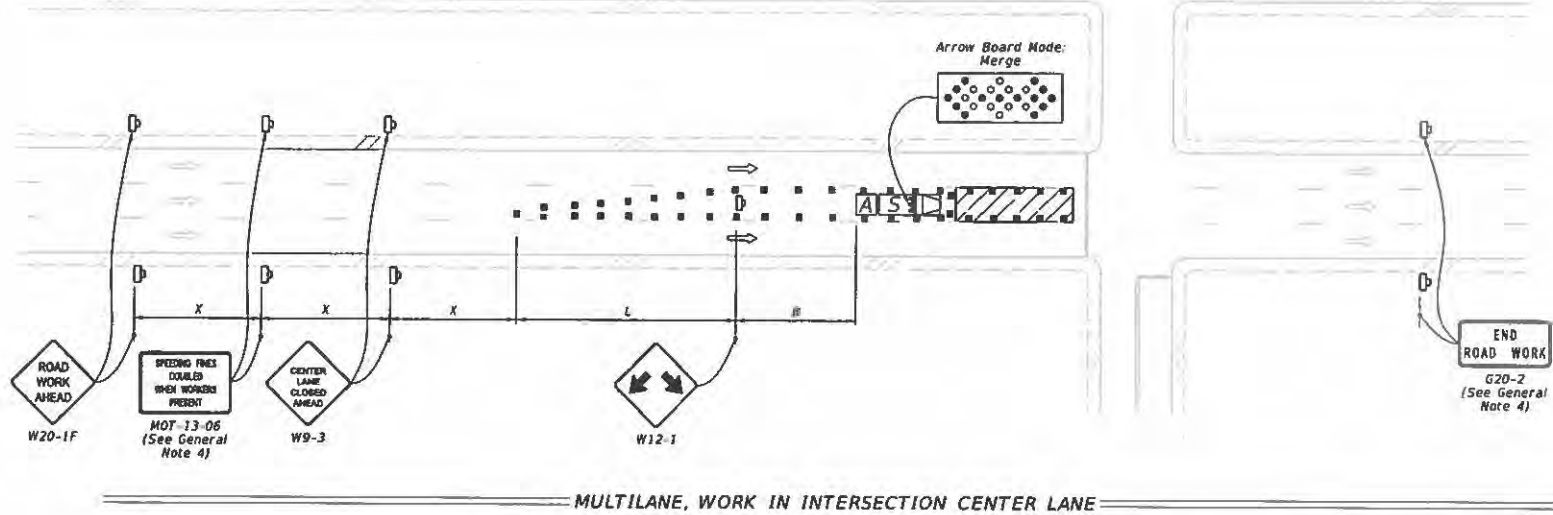

MULTILANE, WORK IN INTERSECTION CENTER LANE

**NOTES:**

1. Confine work operations to one center travel lane and leave the adjacent travel lanes open to traffic.
2. Ensure that the merging taper only directs vehicular traffic into either the right or left lane.

**SYMBOLS:**

- Work Area
- Channelizing Device (See Index 102-600)
- Work Zone Sign
- Type III Barricade
- Arrow Board
- Stop Bar
- Shadow (S) Vehicle With Warning Lights And Arrow Board
- Truck/Trailer Mounted Attenuator (TMA)
- Lane Identification and Direction of Traffic

10/17/2022 2:45:37 PM

LAST REVISION 11/01/22	REVISION	DESCRIPTION:		FY 2023-24 STANDARD PLANS	MULTILANE ROADWAY, INTERSECTION WORK	INDEX 102-615	SHEET 4 of 5
---------------------------	----------	--------------	--	------------------------------	--------------------------------------	------------------	-----------------

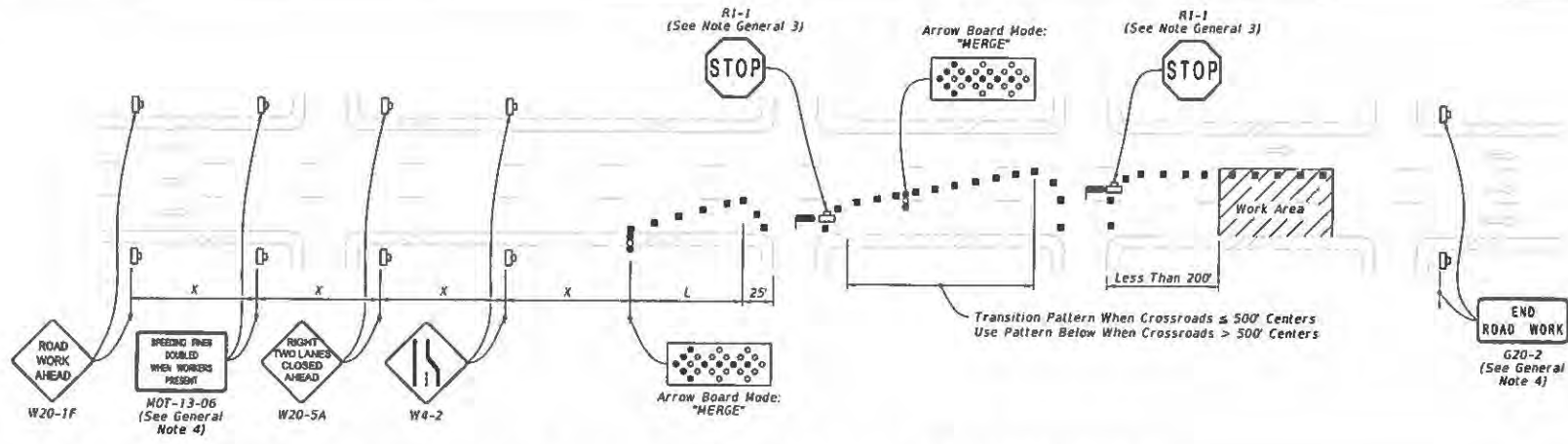

DOUBLE LANE CLOSURE FOR WORK LESS THAN 200' FROM INTERSECTION

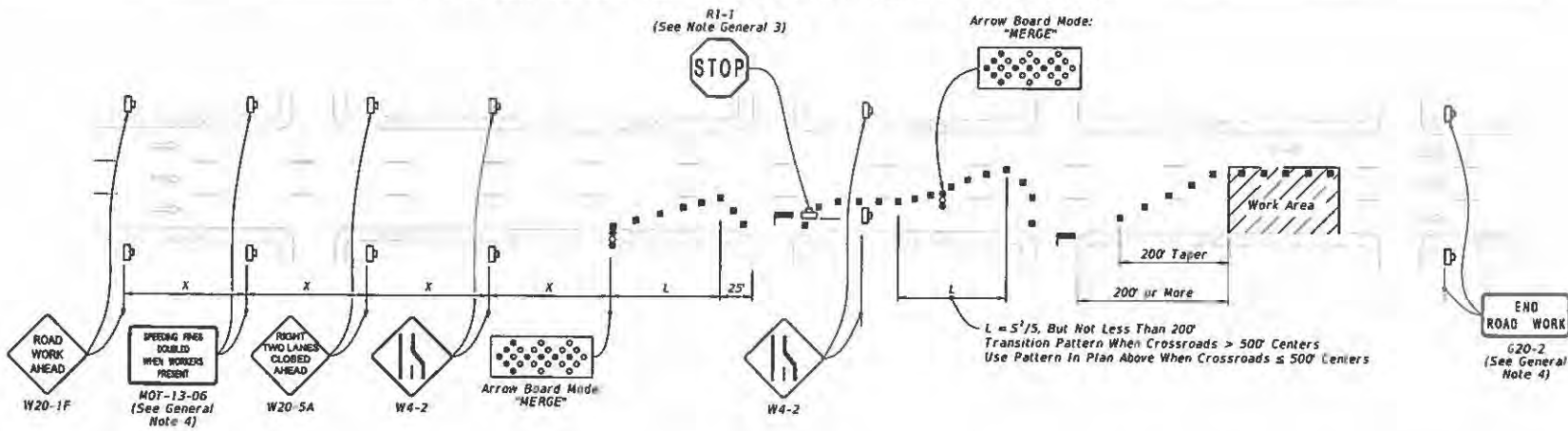

DOUBLE LANE CLOSURE FOR WORK MORE THAN 200' FROM INTERSECTION

SYMBOLS: (See General Note 5)

- Work Area
- Channelizing Device (See Index 102-600)
- Work Zone Sign
- Arrow Board
- Stop Bar
- Lane Identification and Direction of Traffic

LAST REVISION	DESCRIPTION
11/01/22	



FY 2023-24  
STANDARD PLANS

MULTILANE ROADWAY, INTERSECTION WORK





INDEX	SHEET
102-615	5 of 5

10/17/2022 2:45:58 PM

**NOTES:**

1. Cover or deactivate pedestrian traffic signal display(s) controlling closed crosswalks.
2. Place pedestrian LCDs across the full width of the closed sidewalk.
3. For post mounted signs located near or adjacent to a sidewalk, maintain a minimum 7' clearance from the bottom of the sign panel to the surface of the sidewalk.
4. "Sidewalk Closed" signs (R9-XX) may be mounted on pedestrian LCDs in accordance with the manufacturer's instructions.
5. Omit the Advance Closure LCD if it blocks access to other pedestrian facilities (e.g., transit stops, residences, or business entrances).

**SYMBOLS:**

-  Work Area
-  Work Zone Sign
-  Pedestrian Longitudinal Channelizing Device (LCD)
-  Lane Identification and Direction of Traffic

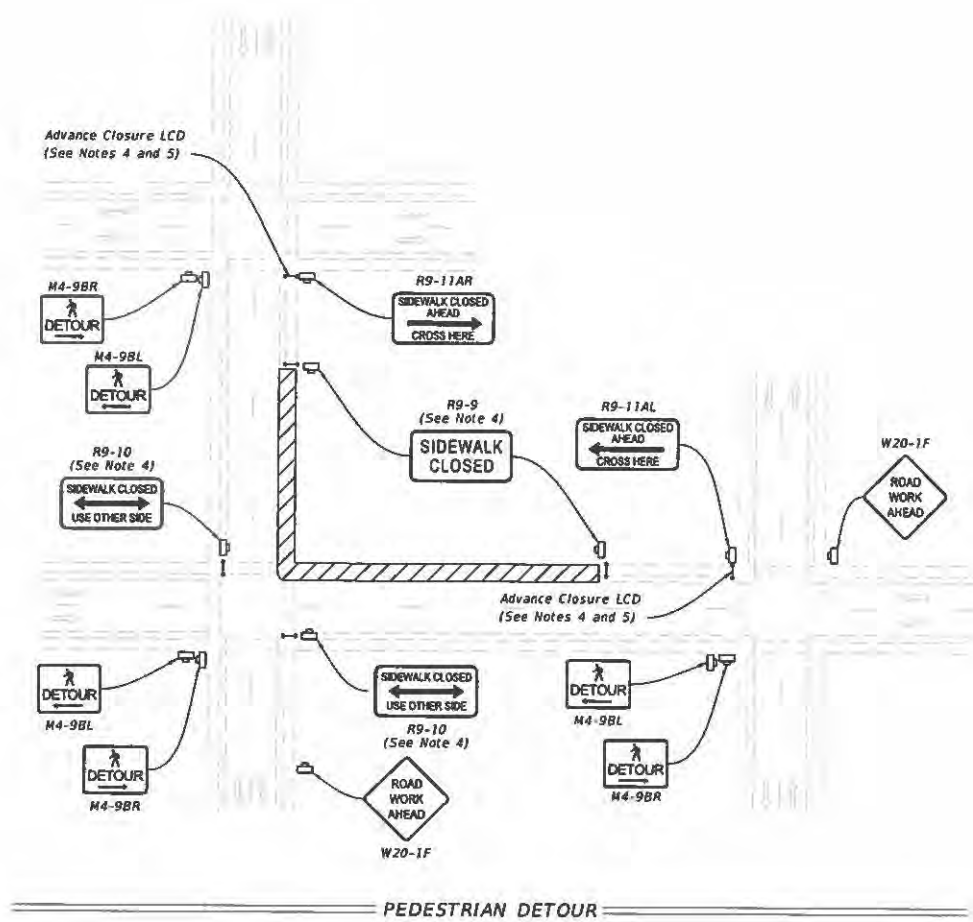

PEDESTRIAN DETOUR









16/06/2024 3:29:25 PM

LAST REVISION 11/01/20	DESCRIPTION:	 FY 2023-24 STANDARD PLANS	<b>SIDEWALK CLOSURE</b>	INDEX 102-660	SHEET 1 of 2
---------------------------	--------------	--	-------------------------	------------------	-----------------

**NOTES:**

1. L = Taper Length  
B = Buffer Length  
X = Work Zone Sign Distance  
See Index 102-600 for "L", "B", "X" channelizing device spacing values.
2. Provide a 5' wide temporary pedestrian way with a maximum cross-slope of 0.02, except where space restrictions warrant a minimum width of 4'. Provide a 5' x 5' passing space for temporary pedestrian ways less than 5' in width at intervals not to exceed 200'.
3. When temporary pedestrian ways require curb ramps, meet the requirements of Index 522-002. Detectable warnings are not required for curb ramps diverting pedestrian traffic into a closed lane.
4. The "Speeding Fines Doubled When Workers Present" signs (MOT-13-06) and "End Road Work" signs (G20-2), along with associated work zone sign distances, may be omitted when the work operation will be in place for 24 hours or less.
5. Pedestrian Diversion Option 2 may only be used when called for in the Plans or as approved by an Engineer.

**SYMBOLS:**

-  Work Area
-  Temporary Pedestrian Way
-  Channelizing Device (See Index 102-600)
-  Pedestrian Longitudinal Channelizing Device (LCD)
-  Work Zone Sign
-  Arrow Board
-  Crash Cushion
-  Lane Identification and Direction of Traffic

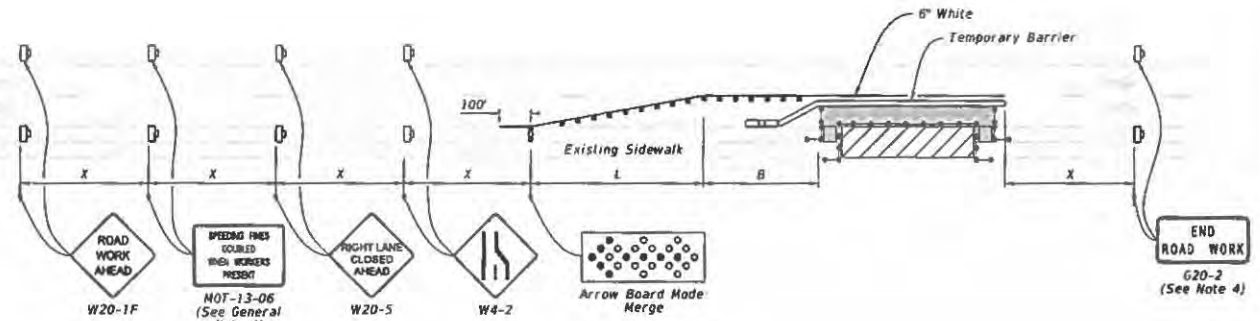

**PEDESTRIAN DIVERSION - OPTION 1**  
(Temporary Barrier Shown, Low Profile Barrier Similar)

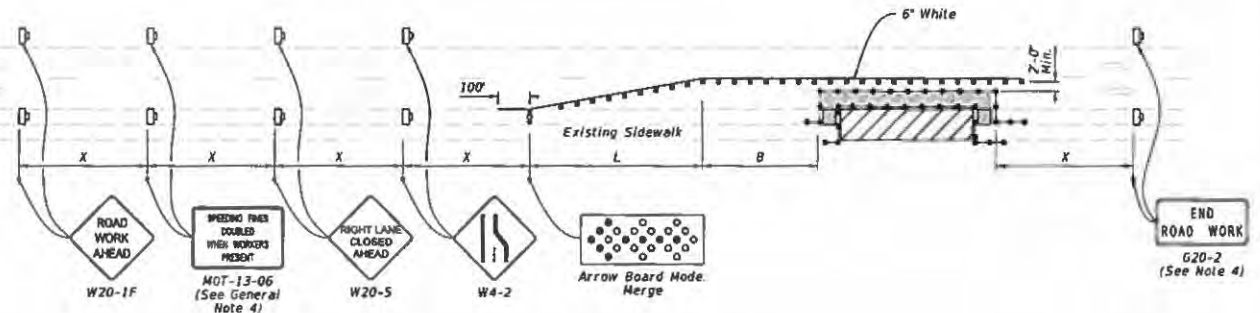

**PEDESTRIAN DIVERSION - OPTION 2**  
(Work Zone Speed 35 mph or Less)

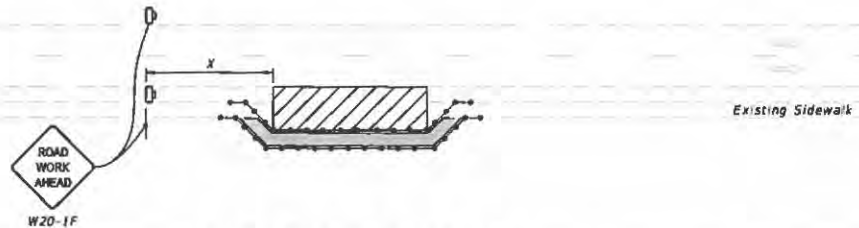

**PEDESTRIAN SPECIAL DETOUR**

2/21/2023 10:19:10 AM

LAST REVISION	DESCRIPTION	FY 2023-24	INDEX	SHEET
11/01/21		STANDARD PLANS	102-660	2 of 2



FY 2023-24  
STANDARD PLANS

**SIDEWALK CLOSURE**

INDEX  
102-660

SHEET  
2 of 2