

BOARD OF COUNTY COMMISSIONERS

REGULAR MEETING

SCHOOL BOARD ADMINISTRATIVE COMPLEX

372 WEST DUVAL STREET

March 07, 2024 at 9:30 AM

CONSENT AGENDA

- (1) BCC Administration - Meeting Minutes - January 18, 2024 - Regular Meeting (pg. 1)
- (2) BCC Administration - Resolution 2024R-03 - Revised SHIP Local Housing Assistance Plan (pg. 6)
- (3) BCC Finance - BA 24-27 - Rezoning and Comprehensive Plan Amendment Application Fees for Parcel 10-4S-16-02867-000 - \$,3600 (pg. 10)
- (4) BCC Finance - Bills and Vouchers - 2/14/24 - \$3,757,518 (pg. 13)
- (5) BCC Finance - Bills and Vouchers - 2/15/24 - \$100 (pg. 28)
- (6) BCC Finance - Bills and Vouchers - 2/28/24 - \$3,046,331 (pg. 31)
- (7) Library Closings for Easter Holiday (pg. 45)
- (8) Public Works - Declaration of Surplus (pg. 47)
- (9) Public Works - Utility Permit from AT&T Requesting to Run a Cable along SE Pounds Hammock (pg. 49)
- (10) Public Works - Utility Permit from AT&T Requesting to Run a Cable along SW Upchurch Ave (pg. 60)
- (11) Public Works - Utility Permit from M.A. Mortenson Company Requesting to Run a Cable along SW Wilson Springs Road (pg. 73)
- (12) Public Works - Utility Permit from Clearwave Fiber Requesting to Install a Cable along SE Deputy J Davis and CR 252B (pg. 78)
- (13) Zoning Department - Special Family Lot Permit SFLP 24 0202 - Wilma Bringger for Daughter Ashley Jones (pg. 91)
- (14) Zoning Department - Special Family Lot Permit SFLP 24 0203 - Timothy and Constance Jones for Daughter Stephanie (pg. 96)



**COLUMBIA COUNTY BOARD OF COUNTY COMMISSIONERS
AGENDA ITEM REQUEST FORM**

The Board of County Commissioners meets the 1st and 3rd Thursday of each month in the Columbia County School Board Administrative Complex Auditorium, 372 West Duval Street, Lake City, Florida 32055. The first meeting of every month is at 9:30AM while the second meeting of every month takes place at 5:30PM. All agenda items are due in the Board's office one week prior to the meeting date.

Today's Date: 3/1/2024 Meeting Date: 3/7/2024

Department: BCC Administration

1. Nature and purpose of agenda item:

Meeting Minutes - January 18, 2024 - Regular Meeting

2. Recommended Motion/Action:

Approve

3. Fiscal impact on current budget.

This item has no effect on the current budget.

Columbia County Board of County Commissioners

January 18th 2024

5:30 PM

The Columbia County Board of County Commissioners met in a regular scheduled meeting held in the auditorium of the School Board Administrative Complex. The meeting opened with an Invocation by Chairman Ronald Williams and Pledge of Allegiance to the Flag of the United States of America followed.

Commissioners in Attendance: Chairman, Ronald Williams

Commissioner, Timothy Murphy

Commissioner, Robby Hollingsworth

Commissioner, Everett Phillips

Commissioner, Rocky Ford

Others in Attendance:

County Manager David Kraus (“CM”)

Assistant County Manager Kevin Kirby (“ACM”)

County Attorney Joel Foreman

Clerk of the Courts James M. Swisher, Jr

Columbia County Sheriff Mark Hunter

Deputy Clerk Susan Heimer

Deputy Clerk Amber Taylor

Meeting called to order by Chairman Williams at 5:36 pm

Agenda Additions/Deletions: (CM) David Kraus noted that an addition be added. Mr. Kraus notified the board that there is currently a vacancy on the Tourist Development Council that needs to be filled. Position is to be filled by Ketna Patel, per Florida Statute 125.0104 was referenced.

Motion by Commissioner Hollingsworth to approve the agenda as amended. The motion was **seconded** by Commissioner Phillips. The motion then carried unanimously.

Presentation:

James Swisher, Clerk of Courts gave presentation regarding free program, the Property Fraud Alert Program, offered by the clerk of court to property owners of Columbia County. This program has been put forth in an effort to spread awareness and prevent fraudulent schemes affecting property owners of Columbia County. This program is accessible to property owners, through the www.Columbiaclerk.com. Each citizen can register up to 5 family members, per registration.

Consent Agenda:

Motion to Approve Consent Agenda: Moved by Commissioner Phillips. Motion **second** by Commissioner Hollingsworth. The motion carried unanimously. See attached.

- 1) BCC Administration – BA 24-40 – Fleet Lease Payments
- 2) BCC Finance – Bills and Vouchers – 1/04/2024 -\$775,363
- 3) Public Works – Utility Permit – City of Lake City Requesting installation of main gas line along South East Forrest Law Way.

Motion to Adopt the Consent Agenda: by Commissioner Hollingsworth to adopt the consent agenda. **Second** by Commissioner Murphy. The motion carried unanimously.

Discussion and Action Items:

County Attorney, Joel Foreman

- 1) Request for adoption hearing to consider an ordinance amending Chapter 62 of the County Code of Ordinances. Specifically, to discuss an ordinance to eliminate the county level Corrections Committee for the Public Safety Coordinating Council.

Motion by Commissioner Murphy to set an adoption hearing for an ordinance to repeal 62-104 of the County Code of Ordinances for February 15, 2024. **Second** by Commissioner Phillips. The motion carried unanimously.

- 2) Request for adoption hearing/ordinance amending Section 74-82 relating to prohibited residences of sexual offenders and sexual predators, per request of the Columbia County Sheriff Mark Hunter.

Kevin Kirby, Assistant County Manager

- 1) Bid No. 2023-09 Westwood Acres Subdivision. C.A.Boone Construction for \$215,300.00

Motion by Commissioner Hollingsworth to award bid No. 2023-09 to C.A. Boone Construction for the total amount of \$215,300 and to approve the agreement. **Second** by Commissioner Phillips. The motion carried unanimously.

- 2) Bid No. 2023-10 NW Leonia Way, NW Queen Road, NW Chambria Way and NW Winfield Street –Anderson Columbia \$3,894,885.29

Motion by Commissioner Ford to award bid No 2023-10 to Anderson Columbia for the total bid amount of \$3,894,885.29. **Second** by Commissioner Phillips. The motion passed unanimously.

David Kraus, County Manager

- 1) Rural Infrastructure Fund Hurricane Idalia Impacted Communities Application

Motion by Commissioner Phillips to authorize Columbia County Economic Development to submit a Rural Infrastructure Fund - Hurricane Idalia grant application for \$900,000.00 to replace the roof in the hanger 0 at the Lake City Gateway Airport. **Second** by Commissioner Hollingsworth. The motion carried unanimously.

- 2) Budget Amendment 24-19 Sheriff Detention Facility return of insurance proceeds to replace 2009 van for \$59,300.67

Motion by Commissioner Ford to approve Budget Amendment 24-19. **Second** by Commissioner Phillips. The motion carried unanimously.

- 3) Resolution 2024-01 Amending Resolution 2023R-72 to include Firefighters not receiving state funded bonus.

Motion by Commissioner Ford to approve resolution 2024R-01. **Second** by Commissioner Murphy, The motion carried unanimously. See attached resolution.

4) North Florida Speedway Event request to hold an event on Thursday, January 25, 2024.

Motion by Commissioner Phillips to approve North Florida Speedway Event request for Thursday January 25, 2024 to have practice in preparation for scheduled event to follow. **Second** by Commissioner Ford. The motion is carried unanimously.

Open Public Comments and or Questions:

Anthony Davis - Citizen Expressed concern with the EMS response time in Columbia County.

(CM) Kraus assured board that he is meeting with Century Ambulatory Services to obtain bid specifications to help address this issue.

Discussion ensued.

Jeff Crawford- Columbia County Fire Chief offered rebuttal as well

Discussion ensued.

Commissioner Ford suggested obtaining comparable information from surrounding counties as to creation of revenue via transfer services versus emergency response calls.

Citizen - Sylvester Warren offered comments on topic of concerns raised by Mr. Davis.

Discussion ensued.

Staff Comments: None

Commissioner Comments: None.

Adjournment:

There being no further business, the meeting adjourned at 6:39PM.

Attest:

Ronald Williams, Chairman
Board of County Commissioners

James M. Swisher, Jr
Clerk of Circuit Court



COLUMBIA COUNTY BOARD OF COUNTY COMMISSIONERS AGENDA ITEM REQUEST FORM

The Board of County Commissioners meets the 1st and 3rd Thursday of each month in the Columbia County School Board Administrative Complex Auditorium, 372 West Duval Street, Lake City, Florida 32055. The first meeting of every month is at 9:30AM while the second meeting of every month takes place at 5:30PM. All agenda items are due in the Board's office one week prior to the meeting date.

Today's Date: 2/15/2024 Meeting Date: 3/7/2024

Department: BCC Administration

1. Nature and purpose of agenda item:

Resolution 2024R-03 Revising SHIP Local Housing Assistance Plan to include the construction of wheelchair ramps on mobile homes..

2. Recommended Motion/Action:

Approve revised Local Housing Assistance Plan

3. Fiscal impact on current budget.

This item has no effect on the current budget.



Suwannee River Economic Council, Inc.

**Post Office Box 70
Live Oak, Florida 32064**

Administrative Office - Phone (386) 362-4115

Fax (386) 362-4078

E-Mail: mattpearson@suwanneec.net

Website: www.srecinc.org

February 13, 2024

Mr. David Kraus
Columbia County Manager
PO Drawer 1529
Lake City FL 32056

Dear Mr. Kraus:

We have been working with Florida Housing Finance Corporation and the Affordable Housing Advisory Committee (AHAC) for the Columbia County SHIP program to revised the Local Housing Assistance Plan, incorporating necessary language allowing the SHIP program to utilize the additional funding provided by the State of Florida through the Hurricane Housing Replacement Program (HHRP).

At the AHAC's most recent meeting, the group approved a measure for the allowance of the construction of wheelchair ramps for mobile homes through the Emergency Repair strategy. The committee also agreed to incorporate mobile homes into the Disaster Repair strategy and to create a Demolition/Reconstruction strategy that will allow for whole home replacement with the HHRP funds.

Since the LHAP currently does not have a Demolition/Reconstruction strategy, Florida Housing Finance Corporation requires the proposal to be sent to their LHAP review committee before it can be sent to the County for approval by the Board of County Commissioners. FHFC's review committee met on February 7th, and approved the proposed LHAP with the added Demolition/Reconstruction strategy.

Enclosed is the LHAP showing the changes approved by FHFC (see yellow highlights on pages 7, 10, 11, and 12) and two Resolutions. If the Board approves the LHAP revision, please return one signed original Resolution to us, and keep the other signed original for the County's records.

If you have any questions about this, please do not hesitate to contact Stephanie Barrington, SHIP Director, at extension *242.

Sincerely,

Matt Pearson
Executive Director

MP/ssb

Enclosures

BRADFORD-COLUMBIA-DIXIE-GILCHRIST-HAMILTON-LAFAYETTE-LEVY-MADISON-PUTNAM-SUWANNEE-TAYLOR-UNION

**"This institution is an equal opportunity provider and employer."
Funded in part through a grant by the State of Florida Department of Elder Affairs**

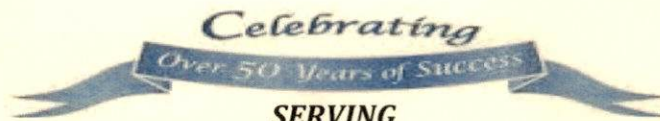

COLUMBIA COUNTY, FLORIDA

RESOLUTION NO. 2024R-03

A Resolution of the Columbia County Board of County Commissioners revising the language to the 2023-2026 SHIP Local Housing Assistance Plan.

WHEREAS it is in the best interest of the citizens of Columbia County, Florida to modify the language in the SHIP Local Housing Assistance Plan as follows:

WHEREAS it is necessary to amend the language as currently stated in the Local Housing Assistance Plan, **Section I, Program Details, Item X General Provisions, Number 6 Eligible Housing** to allow mobile homes manufactured after 1994 to be eligible for Disaster Repair and for wheelchair ramps only in the Emergency Repair strategy, and to allow mobile homes of any age to be eligible for demolition and replacement under the Demolition/Reconstruction strategy when using Hurricane Housing Replacement Funds.

WHEREAS it is necessary to amend the language as currently stated in the Local Housing Assistance Plan, **Section I, Program Details, Item X General Provisions, Number 7 Mortgage Maximums** to limit the total of all mortgages combined in the purchase of a home, excluding approved closing costs, to \$273,000.

WHEREAS it is necessary to amend the language as currently stated in the Local Housing Assistance Plan, **Section II, LHAP STRATEGIES** to add a Demolition/Reconstruction strategy in its entirety.

WHEREAS it is necessary to amend the language as currently stated in the Local Housing Assistance Plan, **Section II, LHAP Strategies, Disaster Repair** to add the language “Repairs of their primary residence to alleviate code violations or improve health hazards, and life and safety issues” as an additional use of funds.

NOW, BE IT RESOLVED BY THE BOARD OF COUNTY COMMISSION OF COLUMBIA COUNTY, FLORIDA THAT the above stated language is hereby amended in the 2023-2026 SHIP Local Housing Assistance Plan.

Passed and adopted this _____ day of _____, 2024.

Ronald Williams
Chairman, Board of County Commissioners
Columbia County, Florida

ATTEST:

James. M. Swisher, Jr., Clerk of Court
Columbia county, Florida



**COLUMBIA COUNTY BOARD OF COUNTY COMMISSIONERS
AGENDA ITEM REQUEST FORM**

The Board of County Commissioners meets the 1st and 3rd Thursday of each month in the Columbia County School Board Administrative Complex Auditorium, 372 West Duval Street, Lake City, Florida 32055. The first meeting of every month is at 9:30AM while the second meeting of every month takes place at 5:30PM. All agenda items are due in the Board's office one week prior to the meeting date.

Today's Date: 1/19/2024 **Meeting Date:** 3/7/2024

Department: BCC Administration

1. Nature and purpose of agenda item:

To transfer funds for the Rezoning and Comprehensive Plan Amendment Application Fees on parcel 10-4S-16-02867-000. This parcel is involved in potential litigation. Holding the hearing to consider rezoning the property will resolve the potential litigation. Transferring the funds to the Building and Zoning Department will cover the costs of the process while our insurance carrier resolves the potential claim.

2. Recommended Motion/Action:

Approve BA 24-27

3. Fiscal impact on current budget.

This item is not budgeted. The proposed budget amendment to fund this request is provided below. The budget amendment number is BA 24-27 using fund(s) 001-GENERAL FUND and 102-MSBU.

| FROM: | TO: | AMOUNT: |
|--|--|------------|
| 001-1000-511.30-31 OPERATING EXPENDITURES/PROFESSIONAL SERVICES | 001-8100-581.91-02 INTERFUND TRANSFERS OUT/TO MSBU FUND | \$3,600.00 |
| 102-0000-381.90-01 INTERFUND TRANSFERS IN/FROM GENERAL FUND | 102-0000-329.10-00 LAND USE AMENDMENTS/ | \$3,600.00 |



Building and Zoning Department

Site Specific Amendment to the Official Zoning Atlas (Rezoning) Application

329.10-00

Invoice

63956

| Applicant Information |
|--|
| Brian Linton & Jeffrey Ruffo 2779 SW SR 247, Lake City, FL. |

| Invoice Date |
|--------------|
| 01/23/2024 |

| Permit # |
|----------|
| Z240101 |

| Amount Due |
|-------------------|
| \$1,850.00 |

Job Location
 Parcel: 10-4S-16-02867-000
 Owner: LINTON BRIAN, RUFFO JEFFERY
 Address: 2779 SW SR 247, Lake City, FL.

| Contractor Information |
|------------------------|
| |

Invoice History

| Date | Description | Amount |
|--------------------|--------------------------------------|------------------|
| 01/23/2024 | Fee: Amend the Official Zoning Atlas | \$1850.00 |
| Amount Due: | | \$1850.00 |

| Contact Us |
|--|
| Phone: (386) 758-1008 |
| Customer Service Hours: Monday-Friday From 8:00 A.M. to 4:30 P.M. |
| Email: bidginfo@columbiacountyfla.com |
| Website: http://www.columbiacountyfla.com/BuildingandZoning.asp |
| Address: Building and Zoning Ste. B-21 135 NE Hernando Ave. Lake City, FL 32055 |

[Credit card payments can be made online here \(fees apply\)](#)

Fee balances are not immediately updated using online Credit Card. If you have paid permit fees using the online application site or by another method such as check or cash, please allow time for your payment to be processed.

| Inspection Office Hours |
|---|
| Monday - Friday From 8:00 AM to 10:00 AM and From 1:30 PM to 3:00 PM |

| Inspection Requests | |
|---|---|
| Online: (Preferred Method) www.columbiacountyfla.com/InspectionRequest.asp | Voice Mail: 386-719-2023 or Phone: 386-758-1008 |
| All Driveway Inspections: 386-758-1019 | Septic Release Inspections: 386-758-1058 |
| IMPORTANT NOTICE: Any inspection requested after 4:30 pm, no matter the method, will be received the next business day and will be scheduled by the earliest time slot. | |
| All inspections require 24 hours notice. Emergencies will be inspected as soon as possible. | |

| Regular Inspection Schedules |
|--|
| <u>All areas North of County Road 242</u> From 10:00 AM to Noon |
| <u>All areas South of County Road 242</u> From 3:00 PM to 5:00 PM |



Building and Zoning Department

Comprehensive Plan Amendment Application

Invoice

63957

| Applicant Information |
|--|
| LINTON BRIAN, RUFFO JEFFERY 2779 SW SR 247, Lake City, fl. |

| Invoice Date |
|--------------|
| 01/23/2024 |

| Permit # |
|-----------|
| CPA240101 |

| Amount Due |
|-------------------|
| \$1,750.00 |

Job Location
 Parcel: 10-4S-16-02867-000
 Owner: LINTON BRIAN, RUFFO JEFFERY
 Address: 2779 SW SR 247, Lake City, fl.

| Contractor Information |
|------------------------|
| |

Invoice History

| Date | Description | Amount |
|--------------------|---|------------------|
| 01/23/2024 | Fee: Amend the Future Land Use Plan Map of the Comprehensive Plan - Small Scale Amendment | \$1750.00 |
| Amount Due: | | \$1750.00 |

| Contact Us |
|---|
| Phone: (386) 758-1008 |
| Customer Service Hours: Monday-Friday From 8:00 A.M. to 4:30 P.M. |
| Email: bldginfo@columbiacountyfla.com |
| Website: http://www.columbiacountyfla.com/BuildingandZoning.asp |
| Address: Building and Zoning Ste. B-21 135 NE Hernando Ave. Lake City, FL 32055 |

[Credit card payments can be made online here \(fees apply\)](#)

Fee balances are not immediately updated using online Credit Card. If you have paid permit fees using the online application site or by another method such as check or cash, please allow time for your payment to be processed.

| Inspection Office Hours |
|---|
| Monday - Friday From 8:00 AM to 10:00 AM and From 1:30 PM to 3:00 PM |

| Inspection Requests | |
|---|---|
| Online: (Preferred Method) www.columbiacountyfla.com/InspectionRequest.asp | Voice Mail: 386-719-2023 or Phone: 386-758-1008 |
| All Driveway Inspections: 386-758-1019 | Septic Release Inspections: 386-758-1058 |
| IMPORTANT NOTICE: Any inspection requested after 4:30 pm, no matter the method, will be received the next business day and will be scheduled by the earliest time slot. | |
| All Inspections require 24 hours notice. Emergencies will be inspected as soon as possible. | |

| Regular Inspection Schedules |
|--|
| <u>All areas North of County Road 242</u> From 10:00 AM to Noon |
| <u>All areas South of County Road 242</u> From 3:00 PM to 5:00 PM |



**COLUMBIA COUNTY BOARD OF COUNTY COMMISSIONERS
AGENDA ITEM REQUEST FORM**

The Board of County Commissioners meets the 1st and 3rd Thursday of each month in the Columbia County School Board Administrative Complex Auditorium, 372 West Duval Street, Lake City, Florida 32055. The first meeting of every month is at 9:30AM while the second meeting of every month takes place at 5:30PM. All agenda items are due in the Board's office one week prior to the meeting date.

Today's Date: 2/15/2024 Meeting Date: 3/7/2024

Department: Finance

1. Nature and purpose of agenda item:

This item requests Board approval for the payment of bills and vouchers in the amount of \$3,757,518.28 submitted 2/14/24. All funds authorized for the issuance of these checks have been budgeted. The Clerk to the Board office reviews bills and vouchers submitted for approval. If for any reason, any of these bills are not recommended for approval, the Clerk to Board office will notify the Board. The Clerk to the Board office maintains copies of invoices and supporting documentation for review.

2. Recommended Motion/Action:

Approve payment of bills and vouchers in the amount of \$3,757,518.28

3. Fiscal impact on current budget.

This item has no effect on the current budget.

COLUMBIA COUNTY BOARD OF COMMISSIONERS ACCOUNTS PAYABLE CHECK REGISTER

| Check Date | Beginning Check Number | Ending Check Number | Number of Checks | Positive Pay File Upload Date | Check Register Total |
|------------|----------------------------------|---------------------|------------------|-------------------------------|-----------------------|
| 2/14/2024 | 51233 | 51417 | 185 | 2/14/2024 | \$3,757,518.28 |
| | | | | | |
| | | | | | |
| | | | | | |
| | | | | | |
| | | | | | |
| | | | | | |
| | TOTAL CHECKS & AMOUNT | | 185 | | \$3,757,518.28 |

| CHECK NO | VENDOR NO | VENDOR NAME | VOUCHER NO | P.O. NO | DATE | VOUCHER AMOUNT | REMITTANCE AMOUNT | CHECK TOTAL |
|----------|-----------|---------------------------|------------|---------|-----------|----------------|-------------------|--------------|
| 0051233 | 0002783 | A & B CONSTRUCTION | 3270 | P45063 | 2/14/2024 | 400.00 | 400.00 | 400.00 |
| 0051234 | 0002013 | A T & T | 001243 | | 2/14/2024 | 773.75 | | |
| | | | 001244 | | 2/14/2024 | 3,015.00 | | |
| | | | 001245 | | 2/14/2024 | 190.00 | | |
| | | | 001246 | | 2/14/2024 | 190.00 | | |
| | | | 001247 | | 2/14/2024 | 190.00 | 4,358.75 | 4,358.75 |
| 0051235 | 0006049 | ACF STANDBY SYSTEMS, LLC | 2244 | | 2/14/2024 | 199.00 | | |
| | | | 2252 | | 2/14/2024 | 199.00 | | |
| | | | 3312 | P45192 | 2/14/2024 | 199.00 | | |
| | | | 3313 | P45193 | 2/14/2024 | 199.00 | | |
| | | | 3426 | P45214 | 2/14/2024 | 199.00 | 995.00 | 995.00 |
| 0051236 | 0001207 | ADVANCE AUTO PARTS | 3336 | P45227 | 2/14/2024 | 297.78 | | |
| | | | 3368 | P45140 | 2/14/2024 | 96.83 | 394.61 | 394.61 |
| 0051237 | 0006039 | ADVANCED CERTIFIED ENVIRO | 3318 | P45185 | 2/14/2024 | 1,985.00 | 1,985.00 | 1,985.00 |
| 0051238 | 0001547 | ADVANCED ENVIRONMENTAL LA | 3309 | P45348 | 2/14/2024 | 170.00 | | |
| | | | 3348 | P45349 | 2/14/2024 | 181.90 | | |
| | | | 3415 | P45326 | 2/14/2024 | 74.00 | 425.90 | 425.90 |
| 0051239 | 0004250 | ALTA CONSTRUCTION EQUIPME | 3287 | P45153 | 2/14/2024 | 315.43 | 315.43 | 315.43 |
| 0051240 | 0003871 | AMERICAN FAMILY FITNESS L | 3292 | P45236 | 2/14/2024 | 60.00 | 60.00 | 60.00 |
| 0051241 | 0003894 | AMERICAN PIPE AND TANK, I | 3134 | 027277 | 2/14/2024 | 3,161.00 | | |
| | | | PI3135 | 027277 | 2/14/2024 | 3,161.00 | | |
| | | | 3307 | P45241 | 2/14/2024 | 1,063.00 | | |
| | | | 3308 | P45242 | 2/14/2024 | 2,098.00 | 9,483.00 | 9,483.00 |
| 0051242 | 0000111 | ANDERSON COLUMBIA CO., IN | 3224 | P45148 | 2/14/2024 | 1,326.60 | | |
| | | | 3326 | P45239 | 2/14/2024 | 1,364.00 | | |
| | | | 3335 | P45209 | 2/14/2024 | 895.40 | | |
| | | | 001339 | | 2/14/2024 | 336,337.55 | | |
| | | | 001340 | | 2/14/2024 | 228,272.47 | | |
| | | | 001341 | | 2/14/2024 | 176,581.05 | | |
| | | | 001342 | | 2/14/2024 | 130,801.19 | | |
| | | | 001343 | | 2/14/2024 | 558,219.39 | 1,433,797.65 | 1,433,797.65 |
| 0051243 | 0006060 | ANN C. HODGES | 3504 | P45433 | 2/14/2024 | 1,000.00 | 1,000.00 | 1,000.00 |
| 0051244 | 0002150 | ANNA TOMLINSON | 3449 | P45173 | 2/14/2024 | 298.15 | 298.15 | 298.15 |
| 0051245 | 0005901 | AT&T MOBILITY | 001248 | | 2/14/2024 | 758.08 | | |
| | | | 001249 | | 2/14/2024 | 794.88 | | |
| | | | 001252 | | 2/14/2024 | 149.55 | | |
| | | | 001253 | | 2/14/2024 | 406.85 | | |
| | | | 001254 | | 2/14/2024 | 725.14 | | |
| | | | 001255 | | 2/14/2024 | 45.32 | | |
| | | | 001256 | | 2/14/2024 | 185.28 | | |
| | | | 001257 | | 2/14/2024 | 27.93 | | |
| | | | 001258 | | 2/14/2024 | 195.88 | | |
| | | | 001259 | | 2/14/2024 | 542.47 | | |
| | | | 001260 | | 2/14/2024 | 118.30 | | |
| | | | 001261 | | 2/14/2024 | 185.53 | | |
| | | | 001262 | | 2/14/2024 | 45.32 | | |
| | | | 001263 | | 2/14/2024 | 542.48 | | |
| | | | 001263 | | 2/14/2024 | 118.30 | | |
| | | | 001263 | | 2/14/2024 | 185.55 | | |
| | | | 001263 | | 2/14/2024 | 45.32 | 5,072.18 | 5,072.18 |
| 0051246 | 0004077 | AUTOMATED BUSINESS MACHIN | 3256 | P45093 | 2/14/2024 | 121.00 | 121.00 | 121.00 |
| 0051247 | 0000218 | BAKER & TAYLOR BOOKS | PI3111 | 027081 | 2/14/2024 | 1,066.64 | | |

| CHECK NO | VENDOR NO | VENDOR NAME | VOUCHER NO | P.O. NO | DATE | VOUCHER AMOUNT | REMITTANCE AMOUNT | CHECK TOTAL |
|----------|-----------|---------------------------|------------|---------|-----------|----------------|-------------------|-------------|
| 0051247 | 0000218 | BAKER & TAYLOR BOOKS | PI3112 | 027082 | 2/14/2024 | 330.47 | | |
| | | | PI3137 | 027080 | 2/14/2024 | 353.54 | | |
| | | | PI3138 | 027081 | 2/14/2024 | 518.84 | | |
| | | | PI3139 | 027082 | 2/14/2024 | 200.85 | | |
| | | | PI3141 | 027085 | 2/14/2024 | 19.58 | | |
| | | | PI3142 | 027089 | 2/14/2024 | 460.56 | | |
| | | | PI3147 | 027080 | 2/14/2024 | 119.47 | | |
| | | | PI3148 | 027081 | 2/14/2024 | 180.04 | | |
| | | | PI3149 | 027082 | 2/14/2024 | 204.01 | | |
| | | | PI3150 | 027089 | 2/14/2024 | 338.68 | 3,792.68 | 3,792.68 |
| 0051248 | 0005251 | BATTERIES PLUS | 3403 | P45298 | 2/14/2024 | 17.37 | 17.37 | 17.37 |
| 0051249 | 0000276 | BATTERY DIST OF JAX, INC. | 3262 | P45119 | 2/14/2024 | 117.01 | 117.01 | 117.01 |
| 0051250 | 0003643 | BEARD EQUIPMENT CO. INC. | PI3145 | 027186 | 2/14/2024 | 9,397.84 | 9,397.84 | 9,397.84 |
| 0051251 | 0004746 | BEAVER BULK, INC. | PI3146 | 027196 | 2/14/2024 | 23,111.30 | | |
| | | | PI3161 | 027196 | 2/14/2024 | 15,383.25 | 38,494.55 | 38,494.55 |
| 0051252 | 0000250 | BEST PLUMBING SPECIALTIES | 3205 | P45057 | 2/14/2024 | 118.14 | 118.14 | 118.14 |
| 0051253 | 0005085 | BIBLIOTHECA, LLC | 3401 | P45278 | 2/14/2024 | 970.22 | | |
| | | | 3402 | P45279 | 2/14/2024 | 830.03 | 1,800.25 | 1,800.25 |
| 0051254 | 0000262 | BIELLINGS TIRE | 3192 | P45235 | 2/14/2024 | 436.00 | | |
| | | | 3212 | P45107 | 2/14/2024 | 190.00 | 626.00 | 626.00 |
| 0051255 | 0004680 | BLUE SUMMIT WATERS, LLC | 001301 | | 2/14/2024 | 7.95 | | |
| | | | 001301 | | 2/14/2024 | 7.95 | | |
| | | | 001301 | | 2/14/2024 | 1.00- | | |
| | | | 001301 | | 2/14/2024 | 9.95 | | |
| | | | 001301 | | 2/14/2024 | 11.00 | | |
| | | | 001301 | | 2/14/2024 | 43.00 | | |
| | | | 001301 | | 2/14/2024 | 25.15 | | |
| | | | 001301 | | 2/14/2024 | 25.15 | | |
| | | | 001301 | | 2/14/2024 | 27.10 | | |
| | | | 001301 | | 2/14/2024 | 6.00 | | |
| | | | 001301 | | 2/14/2024 | 31.15 | | |
| | | | 001301 | | 2/14/2024 | 56.95 | | |
| | | | 001301 | | 2/14/2024 | 27.10 | | |
| | | | 001301 | | 2/14/2024 | 33.10 | | |
| | | | 001301 | | 2/14/2024 | 19.15 | | |
| | | | 001301 | | 2/14/2024 | 15.00 | | |
| | | | 001301 | | 2/14/2024 | 17.20 | | |
| | | | 001301 | | 2/14/2024 | 41.05 | | |
| | | | 001301 | | 2/14/2024 | 6.00 | | |
| | | | 001301 | | 2/14/2024 | 49.00 | | |
| | | | 001301 | | 2/14/2024 | 60.85 | | |
| | | | 001301 | | 2/14/2024 | 27.10 | | |
| | | | 001301 | | 2/14/2024 | 51.80 | | |
| | | | 001301 | | 2/14/2024 | 51.65 | | |
| | | | 001301 | | 2/14/2024 | 57.65 | | |
| | | | 001301 | | 2/14/2024 | 5.00 | | |
| | | | 001301 | | 2/14/2024 | 93.35 | | |
| | | | 001301 | | 2/14/2024 | 49.70 | | |
| | | | 001301 | | 2/14/2024 | 17.95 | | |
| | | | 001301 | | 2/14/2024 | 9.95 | | |
| | | | 001301 | | 2/14/2024 | 17.90 | | |
| | | | 001301 | | 2/14/2024 | 27.85 | 928.70 | 928.70 |

PROGRAM GM344LR
COLUMBIA COUNTY
BANK 00

| CHECK NO | VENDOR NO | VENDOR NAME | VOUCHER NO | P.O. NO | DATE | VOUCHER AMOUNT | REMITTANCE AMOUNT | CHECK TOTAL |
|----------|-----------|---------------------------|------------|---------|-----------|----------------|-------------------|-------------|
| 0051256 | 0005872 | BUCHANAN INGERSOLL& ROONE | PI3117 | 027243 | 2/14/2024 | 6,500.00 | | |
| | | | PI3122 | 027243 | 2/14/2024 | 6,500.00 | | |
| | | | PI3123 | 027243 | 2/14/2024 | 6,500.00 | | |
| | | | PI3124 | 027243 | 2/14/2024 | 6,500.00 | | |
| | | | PI3162 | 027289 | 2/14/2024 | 8,000.00 | | |
| | | | PI3163 | 027289 | 2/14/2024 | 8,000.00 | | |
| | | | PI3187 | 027289 | 2/14/2024 | 8,000.00 | | |
| | | | PI3188 | 027289 | 2/14/2024 | 8,000.00 | | |
| | | | PI3189 | 027289 | 2/14/2024 | 8,000.00 | | |
| | | | PI3190 | 027289 | 2/14/2024 | 8,000.00 | 74,000.00 | 74,000.00 |
| 0051257 | 0005110 | CANDLER MOSES & ASSOCIATE | 001344 | | 2/14/2024 | 6,750.00 | 6,750.00 | 6,750.00 |
| 0051258 | 0001796 | CAROLYN HEIGHTS WATER CO. | 3215 | P45111 | 2/14/2024 | 130.84 | 130.84 | 130.84 |
| 0051259 | 0001513 | CCP INDUSTRIES | 3490 | P45400 | 2/14/2024 | 217.35 | 217.35 | 217.35 |
| 0051260 | 0008097 | CHAMBER OF COMMERCE | 3272 | P45133 | 2/14/2024 | 225.00 | 225.00 | 225.00 |
| 0051261 | 0000382 | CITY ELECTRIC SUPPLY, INC | 3242 | P45127 | 2/14/2024 | 210.48 | 210.48 | 210.48 |
| 0051262 | 0002978 | CITY OF JACKSONVILLE | 001267 | | 2/14/2024 | 31,625.00 | | |
| | | | 001268 | | 2/14/2024 | 25.00 | 31,650.00 | 31,650.00 |
| 0051263 | 0000304 | CITY OF LAKE CITY - UTILI | 001250 | | 2/14/2024 | 610.19 | | |
| | | | 001316 | | 2/14/2024 | 609.56 | | |
| | | | 001328 | | 2/14/2024 | 236.05 | | |
| | | | 001329 | | 2/14/2024 | 311.11 | | |
| | | | 001330 | | 2/14/2024 | 103.71 | | |
| | | | 001331 | | 2/14/2024 | 15,070.17 | | |
| | | | 001332 | | 2/14/2024 | 1,054.23 | | |
| | | | 001333 | | 2/14/2024 | 182.27 | | |
| | | | 001334 | | 2/14/2024 | 210.68 | | |
| | | | 001335 | | 2/14/2024 | 26.88 | | |
| | | | 001336 | | 2/14/2024 | 145.26 | | |
| | | | 001337 | | 2/14/2024 | 290.05 | 18,850.16 | 18,850.16 |
| 0051264 | 0004421 | CITY OF PERRY | 3494 | P45420 | 2/14/2024 | 70.74 | 70.74 | 70.74 |
| 0051265 | 0000308 | CLAY ELECTRIC COOPERATIVE | 3495 | P45422 | 2/14/2024 | 184.68 | 184.68 | 184.68 |
| 0051266 | 0006271 | CLEARWAVE FIBER | 001250 | | 2/14/2024 | 1,294.93 | | |
| | | | 001250 | | 2/14/2024 | 1,547.33 | | |
| | | | 001250 | | 2/14/2024 | 886.62 | | |
| | | | 001250 | | 2/14/2024 | 5,031.69 | | |
| | | | 001305 | | 2/14/2024 | 2,467.46 | | |
| | | | 001306 | | 2/14/2024 | 2,467.46 | | |
| | | | 001307 | | 2/14/2024 | 1,577.64 | | |
| | | | 001308 | | 2/14/2024 | 946.59 | | |
| | | | 001309 | | 2/14/2024 | 946.59 | | |
| | | | 001310 | | 2/14/2024 | 4,006.05 | | |
| | | | 001311 | | 2/14/2024 | 599.51 | | |
| | | | 001312 | | 2/14/2024 | 599.51 | | |
| | | | 001313 | | 2/14/2024 | 1,230.56 | | |
| | | | 001314 | | 2/14/2024 | 704.69 | 24,306.63 | 24,306.63 |
| 0051267 | 0004021 | COLUMBIA COUNTY UTILITY S | 001250 | | 2/14/2024 | 43.63 | | |
| | | | 001250 | | 2/14/2024 | 119.98 | | |
| | | | 001250 | | 2/14/2024 | 43.63 | | |
| | | | 001250 | | 2/14/2024 | 43.63 | | |
| | | | 001250 | | 2/14/2024 | 24.31 | | |
| | | | 001250 | | 2/14/2024 | 24.31 | 299.49 | 299.49 |
| 0051268 | 0002822 | COMCAST, GRP-1 | 001250 | | 2/14/2024 | 549.57 | 549.57 | 549.57 |

PROGRAM GM344LR
COLUMBIA COUNTY
BANK 00

| CHECK NO | VENDOR NO | VENDOR NAME | VOUCHER NO | P.O. NO | DATE | VOUCHER AMOUNT | REMITTANCE AMOUNT | CHECK TOTAL |
|----------|-----------|-----------------------------|------------|---------|-----------|----------------|-------------------|-------------|
| 0051269 | 0002822 | COMCAST,GRP-2 | 001317 | | 2/14/2024 | 119.85 | 119.85 | 119.85 |
| 0051270 | 0002822 | COMCAST,GRP-3 | 001318 | | 2/14/2024 | 272.66 | 272.66 | 272.66 |
| 0051271 | 0002822 | COMCAST,GRP-4 | 001318 | | 2/14/2024 | 333.79 | 333.79 | 333.79 |
| 0051272 | 0002822 | COMCAST,GRP-5 | 3346 | P45324 | 2/14/2024 | 182.99 | 182.99 | 182.99 |
| 0051273 | 0002822 | COMCAST,GRP-6 | 3347 | P45325 | 2/14/2024 | 148.35 | 148.35 | 148.35 |
| 0051274 | 0002822 | COMCAST,GRP-7 | 3498 | P45425 | 2/14/2024 | 164.90 | 164.90 | 164.90 |
| 0051275 | 0002822 | COMCAST,GRP-8 | 3499 | P45426 | 2/14/2024 | 199.19 | 199.19 | 199.19 |
| 0051276 | 0000353 | COMCAST BUSINESS | 3432 | P45157 | 2/14/2024 | 337.80 | 337.80 | 337.80 |
| 0051277 | 0004830 | COMCAST CABLE COMMUNICATI | 3406 | P45329 | 2/14/2024 | 106.85 | 106.85 | 106.85 |
| 0051278 | 0004609 | COX FIRE PROTECTION, INC. | 3323 | P45190 | 2/14/2024 | 137.00 | | |
| | | | 3324 | P45191 | 2/14/2024 | 537.00 | 674.00 | 674.00 |
| 0051279 | 0003614 | CO2 DIRECT GAS, INC. | 3441 | P45373 | 2/14/2024 | 23.00 | 23.00 | 23.00 |
| 0051280 | 0005838 | CREATIVE CONCEPTS HOME ANPI | 3152 | 027101 | 2/14/2024 | 8,536.38 | 8,536.38 | 8,536.38 |
| 0051281 | 0004846 | CREATIVE CONCRETE DESIGN | PI3143 | 027123 | 2/14/2024 | 891.00 | | |
| | | | PI3184 | 027278 | 2/14/2024 | 16,959.25 | | |
| | | | PI3305 | 027123 | 2/14/2024 | 2,235.60 | | |
| | | | PI3306 | 027123 | 2/14/2024 | 1,875.00 | | |
| | | | 3461 | P45313 | 2/14/2024 | 1,292.00 | | |
| | | | 3462 | P45313 | 2/14/2024 | 229.50 | | |
| | | | 3463 | P45313 | 2/14/2024 | 720.00 | 24,202.35 | 24,202.35 |
| 0051282 | 0002417 | CRYSTAL SPRINGS | 3507 | P45436 | 2/14/2024 | 26.59 | 26.59 | 26.59 |
| 0051283 | 0000445 | DARABI AND ASSOC., INC. | 001318 | | 2/14/2024 | 2,916.70 | 2,916.70 | 2,916.70 |
| 0051284 | 0004724 | DARBY PEELE CRAPPS & GREE | 001269 | | 2/14/2024 | 20,000.00 | 20,000.00 | 20,000.00 |
| 0051285 | 0004144 | DEBORAH L. HORNER | 3382 | P45355 | 2/14/2024 | 17.80 | 17.80 | 17.80 |
| 0051286 | 0000440 | DELL MARKETING L.P. | PI3114 | 027206 | 2/14/2024 | 3,961.62 | | |
| | | | PI3115 | 027206 | 2/14/2024 | 603.54 | | |
| | | | 3277 | P45138 | 2/14/2024 | 643.96 | | |
| | | | 3418 | P45384 | 2/14/2024 | 2,141.98 | 7,351.10 | 7,351.10 |
| 0051287 | 0000467 | DEPT. OF ENVIR. PROTECTIO | 3325 | P45211 | 2/14/2024 | 50.00 | 50.00 | 50.00 |
| 0051288 | 0000460 | DOUGLAS LAW DBA DOUGLAS & | 001345 | | 2/14/2024 | 500.00 | 500.00 | 500.00 |
| 0051289 | 0000615 | DUKE ENERGY | 001250 | | 2/14/2024 | 32.02 | | |
| | | | 001250 | | 2/14/2024 | 30.79 | | |
| | | | 001250 | | 2/14/2024 | 32.02 | | |
| | | | 3496 | P45423 | 2/14/2024 | 265.97 | | |
| | | | 3497 | P45424 | 2/14/2024 | 323.50 | 684.30 | 684.30 |
| 0051290 | 0006174 | ENTERPRISE FM TRUST | 001045 | | 2/14/2024 | 502.25 | | |
| | | | 001046 | | 2/14/2024 | 137.67 | | |
| | | | 001047 | | 2/14/2024 | 120.95 | | |
| | | | 001047 | | 2/14/2024 | 3,618.98 | | |
| | | | 001047 | | 2/14/2024 | 1,110.98 | | |
| | | | 001047 | | 2/14/2024 | 773.52 | | |
| | | | 001047 | | 2/14/2024 | 388.11 | | |
| | | | 001047 | | 2/14/2024 | 107.82 | | |
| | | | 001047 | | 2/14/2024 | 107.33 | | |
| | | | 001047 | | 2/14/2024 | 1,720.23 | | |
| | | | 001047 | | 2/14/2024 | 487.45 | | |
| | | | 001047 | | 2/14/2024 | 344.97 | | |
| | | | 001047 | | 2/14/2024 | 1,057.06 | | |
| | | | 001047 | | 2/14/2024 | 315.65 | | |
| | | | 001047 | | 2/14/2024 | 225.84 | | |
| | | | 001047 | | 2/14/2024 | 2,114.12 | | |
| | | | 001047 | | 2/14/2024 | 624.52 | | |

| CHECK NO | VENDOR NO | VENDOR NAME | VOUCHER NO | P.O. NO | DATE | VOUCHER AMOUNT | REMITTANCE AMOUNT | CHECK TOTAL |
|----------|-----------|---------------------------|------------|---------|-----------|----------------|-------------------|-------------|
| 0051290 | 0006174 | ENTERPRISE FM TRUST | 001047 | | 2/14/2024 | 451.68 | | |
| | | | 001047 | | 2/14/2024 | 2,298.05 | | |
| | | | 001047 | | 2/14/2024 | 681.91 | | |
| | | | 001047 | | 2/14/2024 | 493.49 | | |
| | | | 001047 | | 2/14/2024 | 14,257.15 | | |
| | | | 001047 | | 2/14/2024 | 4,435.37 | | |
| | | | 001047 | | 2/14/2024 | 3,039.31 | | |
| | | | 001047 | | 2/14/2024 | 1,052.34 | | |
| | | | 001047 | | 2/14/2024 | 323.62 | | |
| | | | 001047 | | 2/14/2024 | 225.30 | | |
| | | | 001047 | | 2/14/2024 | 564.61 | | |
| | | | 001047 | | 2/14/2024 | 170.23 | | |
| | | | 001047 | | 2/14/2024 | 103.56 | | |
| | | | 001047 | | 2/14/2024 | 571.96 | | |
| | | | 001047 | | 2/14/2024 | 180.62 | | |
| | | | 001047 | | 2/14/2024 | 110.16 | | |
| | | | 001300 | | 2/14/2024 | 2,104.68 | | |
| | | | 001300 | | 2/14/2024 | 644.05 | | |
| | | | 001300 | | 2/14/2024 | 450.60 | | |
| | | | 001300 | | 2/14/2024 | 7,955.00 | 37,961.14 | 37,961.14 |
| 0051291 | 0003406 | ESRI, INC. | 001346 | | 2/14/2024 | 14,685.00 | | |
| | | | 001347 | | 2/14/2024 | 1,400.00 | | |
| | | | 001348 | | 2/14/2024 | 920.00 | 17,005.00 | 17,005.00 |
| 0051292 | 0006071 | FERREIRA FUNERAL SERVICES | 001318 | | 2/14/2024 | 450.00 | 450.00 | 450.00 |
| 0051293 | 0003640 | FLORIDA CHAMBER OF COMERC | 3273 | P45134 | 2/14/2024 | 500.00 | 500.00 | 500.00 |
| 0051294 | 0000642 | FLORIDA PEST CONTROL | 3206 | P45085 | 2/14/2024 | 31.00 | | |
| | | | 3237 | P45122 | 2/14/2024 | 25.00 | | |
| | | | 3269 | P45058 | 2/14/2024 | 25.00 | | |
| | | | 3321 | P45310 | 2/14/2024 | 41.00 | | |
| | | | 3425 | P45447 | 2/14/2024 | 32.00 | | |
| | | | 3431 | P45411 | 2/14/2024 | 606.00 | | |
| | | | 3435 | P45160 | 2/14/2024 | 35.00 | | |
| | | | 3443 | P45401 | 2/14/2024 | 391.00 | 1,186.00 | 1,186.00 |
| 0051295 | 0006092 | FLORIDA RURAL ECONOMIC DE | 3276 | P45137 | 2/14/2024 | 2,375.00 | 2,375.00 | 2,375.00 |
| 0051296 | 0004154 | FORT WHITE TRUE VALUE HAR | 3245 | P45121 | 2/14/2024 | 56.90 | | |
| | | | 3484 | P45377 | 2/14/2024 | 43.48 | | |
| | | | 3485 | P45378 | 2/14/2024 | 59.48 | 159.86 | 159.86 |
| 0051297 | 0004689 | FORTILINE, INC. | 3374 | P45271 | 2/14/2024 | 407.04 | | |
| | | | 3429 | P45382 | 2/14/2024 | 1,186.88 | 1,593.92 | 1,593.92 |
| 0051298 | 0006028 | FUELED OUTDOORS | 3344 | P45002 | 2/14/2024 | 169.38 | 169.38 | 169.38 |
| 0051299 | 0000806 | G.W. HUNTER, INC. | PI3144 | 027124 | 2/14/2024 | 24,510.88 | | |
| | | | 3359 | P45129 | 2/14/2024 | 32.16 | | |
| | | | 3360 | P45131 | 2/14/2024 | 27.09 | | |
| | | | 3361 | P45132 | 2/14/2024 | 60.81 | | |
| | | | 3362 | P45139 | 2/14/2024 | 42.61 | | |
| | | | 3365 | P45229 | 2/14/2024 | 317.90 | | |
| | | | PI3413 | 027131 | 2/14/2024 | 23,806.01 | | |
| | | | PI3414 | 027132 | 2/14/2024 | 8,213.25 | | |
| | | | 3430 | P45207 | 2/14/2024 | 52.21 | | |
| | | | 3479 | P45327 | 2/14/2024 | 60.97 | | |
| | | | 3492 | P45367 | 2/14/2024 | 68.21 | 57,192.10 | 57,192.10 |
| 0051300 | 0000702 | GALLS, LLC | 3420 | P45294 | 2/14/2024 | 385.36 | | |

| CHECK NO | VENDOR NO | VENDOR NAME | VOUCHER NO | P.O. NO | DATE | VOUCHER AMOUNT | REMITTANCE AMOUNT | CHECK TOTAL |
|----------|-----------|---------------------------|------------|---------|-----------|----------------|-------------------|-------------|
| 0051300 | 0000702 | GALLS, LLC | 3421 | P45295 | 2/14/2024 | 129.68 | | |
| | | | 3423 | P45296 | 2/14/2024 | 102.12- | | |
| | | | 3424 | P45297 | 2/14/2024 | 111.32- | 301.60 | 301.60 |
| 0051301 | 0000759 | GATEWAY-FOREST LAWN FUNER | 001270 | | 2/14/2024 | 450.00 | 450.00 | 450.00 |
| 0051302 | 0006247 | GATEWAY GRANT WRITING & A | 3301 | P45212 | 2/14/2024 | 900.00 | 900.00 | 900.00 |
| 0051303 | 0000762 | GENESIS DOOR & HARDWARE, | 3375 | P45302 | 2/14/2024 | 487.50 | 487.50 | 487.50 |
| 0051304 | 0004622 | GIS PLANNING, INC. | PI3110 | 027238 | 2/14/2024 | 3,090.00 | 3,090.00 | 3,090.00 |
| 0051305 | 0000754 | GRAHAM & SONS ELECTRICAL, | PI3167 | 027230 | 2/14/2024 | 17,999.00 | 17,999.00 | 17,999.00 |
| 0051306 | 0000724 | GRAINGER | 3197 | P45098 | 2/14/2024 | 201.50 | | |
| | | | 3198 | P45099 | 2/14/2024 | 64.51 | | |
| | | | 3199 | P45100 | 2/14/2024 | 129.02 | | |
| | | | 3203 | P45101 | 2/14/2024 | 463.82 | | |
| | | | 3230 | P45115 | 2/14/2024 | 180.66 | | |
| | | | 3231 | P45115 | 2/14/2024 | 180.66 | | |
| | | | 3232 | P45116 | 2/14/2024 | 72.14 | | |
| | | | 3233 | P45117 | 2/14/2024 | 64.51 | | |
| | | | 3235 | P45097 | 2/14/2024 | 193.53 | | |
| | | | 3363 | P45186 | 2/14/2024 | 120.44 | | |
| | | | 3370 | P45187 | 2/14/2024 | 240.88 | | |
| | | | 3379 | P45308 | 2/14/2024 | 825.44 | | |
| | | | 3474 | P45399 | 2/14/2024 | 9.22 | 2,746.33 | 2,746.33 |
| 0051307 | 0000745 | GREAT AMERICA FINANCIAL S | 3505 | P45434 | 2/14/2024 | 451.60 | | |
| | | | 3506 | P45435 | 2/14/2024 | 300.89 | 752.49 | 752.49 |
| 0051308 | 0002155 | GUARDIAN COMMUNITY RESOUR | 001271 | | 2/14/2024 | 2,222.22 | | |
| | | | 001272 | | 2/14/2024 | 5,794.44 | | |
| | | | 001273 | | 2/14/2024 | 4,325.00 | | |
| | | | 001274 | | 2/14/2024 | 6,750.00 | 19,091.66 | 19,091.66 |
| 0051309 | 0006072 | GUNSTER, YOAKLEY & STEWAR | 001349 | | 2/14/2024 | 110.00 | 110.00 | 110.00 |
| 0051310 | 0002416 | HAIR HOME & AUTO CENTER, | 3341 | P44978 | 2/14/2024 | 260.95 | 260.95 | 260.95 |
| 0051311 | 0004804 | HAWKINS, INC. | 3486 | P45392 | 2/14/2024 | 429.00 | | |
| | | | 3487 | P45393 | 2/14/2024 | 200.20 | 629.20 | 629.20 |
| 0051312 | 0000818 | HILL MANUFACTURING CO., I | 3247 | P44906 | 2/14/2024 | 574.00 | | |
| | | | 3367 | P45053 | 2/14/2024 | 435.00 | 1,009.00 | 1,009.00 |
| 0051313 | 0002133 | HOME DEPOT CREDIT SERVICE | 3268 | P45238 | 2/14/2024 | 33.92 | 33.92 | 33.92 |
| 0051314 | 0002718 | HOME DEPOT PRO | 3442 | P45398 | 2/14/2024 | 101.36 | 101.36 | 101.36 |
| 0051315 | 0003685 | HUB CITY INDUSTRIAL SUPPL | 3251 | P45068 | 2/14/2024 | 53.16 | | |
| | | | 3288 | P45154 | 2/14/2024 | 49.16 | 102.32 | 102.32 |
| 0051316 | 0000835 | H2 REHABILITATION SERV.OF | 001275 | | 2/14/2024 | 140.00 | | |
| | | | 001276 | | 2/14/2024 | 35.00 | | |
| | | | 001277 | | 2/14/2024 | 105.00 | | |
| | | | 001277 | | 2/14/2024 | 35.00 | 315.00 | 315.00 |
| 0051317 | 0000952 | ICS CREMATION AND FUNERAL | 001318 | | 2/14/2024 | 450.00 | | |
| | | | 001350 | | 2/14/2024 | 450.00 | 900.00 | 900.00 |
| 0051318 | 0005367 | IMMAC POWER SOLUTIONS INC | PI3127 | 027075 | 2/14/2024 | 500.00 | 500.00 | 500.00 |
| 0051319 | 0000911 | INTERSTATE SUPPLY | 3201 | P45060 | 2/14/2024 | 196.49 | | |
| | | | 3225 | P45059 | 2/14/2024 | 458.93 | | |
| | | | 3320 | P45198 | 2/14/2024 | 11.76 | | |
| | | | 3327 | P45240 | 2/14/2024 | 49.98 | | |
| | | | 3337 | P45305 | 2/14/2024 | 125.59 | | |
| | | | 3338 | P45306 | 2/14/2024 | 230.09- | | |
| | | | 3371 | P45194 | 2/14/2024 | 904.80 | | |
| | | | 3395 | P45307 | 2/14/2024 | 71.52 | | |

PROGRAM GM344LR
COLUMBIA COUNTY
BANK 00

| CHECK NO | VENDOR NO | VENDOR NAME | VOUCHER NO | P.O. NO | DATE | VOUCHER AMOUNT | REMITTANCE AMOUNT | CHECK TOTAL |
|----------|-----------|----------------------------|------------|---------|-----------|----------------|-------------------|-------------|
| 0051319 | 0000911 | INTERSTATE SUPPLY | 3465 | P45395 | 2/14/2024 | 69.12 | | |
| | | | 3488 | P45394 | 2/14/2024 | 78.02 | 1,736.12 | 1,736.12 |
| 0051320 | 0006226 | J & J GAS SERVICE, INC | 3266 | P45232 | 2/14/2024 | 525.78 | | |
| | | | 3417 | P45289 | 2/14/2024 | 455.79 | 981.57 | 981.57 |
| 0051321 | 0006124 | JACKSON LIGHTING AND ELEC | PI3128 | 027183 | 2/14/2024 | 6,282.18 | | |
| | | | PI3133 | 027183 | 2/14/2024 | 1,329.63 | 7,611.81 | 7,611.81 |
| 0051322 | 0000310 | JAMES M. SWISHER, JR. | 001277 | | 2/14/2024 | 47,687.00 | 47,687.00 | 47,687.00 |
| 0051323 | 0005924 | JASON ROSENFELD | 001351 | | 2/14/2024 | 240.64 | 240.64 | 240.64 |
| 0051324 | 0005518 | JONES EDMUNDS & ASSOC., IN | 001352 | | 2/14/2024 | 5,289.50 | 5,289.50 | 5,289.50 |
| 0051325 | 0001025 | JSC SYSTEMS, INC. | 3353 | P45195 | 2/14/2024 | 350.00 | 350.00 | 350.00 |
| 0051326 | 0001102 | KEATON LOCKSMITHS | 3322 | P45184 | 2/14/2024 | 1,210.99 | 1,210.99 | 1,210.99 |
| 0051327 | 0001968 | KIMI ROBERTS | 001277 | | 2/14/2024 | 8.46 | | |
| | | | 001277 | | 2/14/2024 | 8.28 | | |
| | | | 001277 | | 2/14/2024 | 8.28 | 25.02 | 25.02 |
| 0051328 | 0006162 | KIMLEY-HORN AND ASSOCIATE | 001353 | | 2/14/2024 | 365.00 | 365.00 | 365.00 |
| 0051329 | 0006126 | KNIGHT TECHNOLOGY GROUP | PI3118 | 027258 | 2/14/2024 | 2,835.56 | | |
| | | | PI3119 | 027267 | 2/14/2024 | 5,081.28 | | |
| | | | PI3125 | 027249 | 2/14/2024 | 2,842.78 | | |
| | | | 3283 | P45149 | 2/14/2024 | 707.00 | | |
| | | | 3284 | P45150 | 2/14/2024 | 105.54 | | |
| | | | 3285 | P45150 | 2/14/2024 | 81.00 | | |
| | | | 3291 | P45216 | 2/14/2024 | 839.76 | | |
| | | | 3372 | P45210 | 2/14/2024 | 296.22 | | |
| | | | 3476 | P45301 | 2/14/2024 | 84.97 | | |
| | | | 3477 | P45301 | 2/14/2024 | 576.60 | | |
| | | | 3478 | P45301 | 2/14/2024 | 493.55 | | |
| | | | 3482 | P45362 | 2/14/2024 | 138.87 | 14,083.13 | 14,083.13 |
| 0051330 | 0001254 | LAINIE INDUSTRIES, INC. | 3475 | P45412 | 2/14/2024 | 6.18 | 6.18 | 6.18 |
| 0051331 | 0001231 | LAKE CITY ADVERTISER | PI3129 | 027202 | 2/14/2024 | 1,000.00 | | |
| | | | 3281 | P45145 | 2/14/2024 | 500.00 | | |
| | | | 3416 | P44407 | 2/14/2024 | 576.45 | 2,076.45 | 2,076.45 |
| 0051332 | 0001212 | LAKE CITY AUTO PARTS | 3286 | P45152 | 2/14/2024 | 14.72 | | |
| | | | 3328 | P44932 | 2/14/2024 | 47.58 | | |
| | | | 3329 | P44933 | 2/14/2024 | 26.66 | | |
| | | | 3330 | P44938 | 2/14/2024 | 210.78 | | |
| | | | 3334 | P44963 | 2/14/2024 | 169.44 | | |
| | | | 3358 | P45092 | 2/14/2024 | 139.00 | | |
| | | | 3369 | P45143 | 2/14/2024 | 60.80 | | |
| | | | 3376 | P45151 | 2/14/2024 | 280.48 | | |
| | | | 3400 | P45272 | 2/14/2024 | 6.78 | | |
| | | | 3407 | P45357 | 2/14/2024 | 8.12 | | |
| | | | 3472 | P45374 | 2/14/2024 | 16.16 | | |
| | | | 3473 | P45380 | 2/14/2024 | 38.97 | 1,019.49 | 1,019.49 |
| 0051333 | 0001224 | LAKE CITY HUMANE SOCIETY, | 001277 | | 2/14/2024 | 31,312.50 | 31,312.50 | 31,312.50 |
| 0051334 | 0001230 | LAKE CITY INDUSTRIES | 3204 | P44817 | 2/14/2024 | 12.07 | | |
| | | | 3226 | P45110 | 2/14/2024 | 21.48 | | |
| | | | 3246 | P45124 | 2/14/2024 | 7.86 | | |
| | | | 3332 | P44952 | 2/14/2024 | 78.55 | | |
| | | | 3342 | P44987 | 2/14/2024 | 43.08 | | |
| | | | 3343 | P45001 | 2/14/2024 | 58.75 | | |
| | | | 3464 | P45323 | 2/14/2024 | 38.40 | | |
| | | | 3489 | P45397 | 2/14/2024 | 5.05 | 265.24 | 265.24 |

| CHECK NO | VENDOR NO | VENDOR NAME | VOUCHER NO | P.O. NO | DATE | VOUCHER AMOUNT | REMITTANCE AMOUNT | CHECK TOTAL |
|----------|-----------|---------------------------|------------|---------|-----------|----------------|-------------------|-------------|
| 0051335 | 0001204 | LAKE CITY REPORTER, INC. | 001280 | | 2/14/2024 | 616.91 | | |
| | | | 001281 | | 2/14/2024 | 237.44 | | |
| | | | 001282 | | 2/14/2024 | 189.42 | | |
| | | | 001283 | | 2/14/2024 | 212.36 | | |
| | | | 001284 | | 2/14/2024 | 172.10 | | |
| | | | 001285 | | 2/14/2024 | 170.12 | | |
| | | | 001286 | | 2/14/2024 | 194.54 | | |
| | | | 001287 | | 2/14/2024 | 66.14 | | |
| | | | 001288 | | 2/14/2024 | 33.22 | | |
| | | | 001289 | | 2/14/2024 | 132.26 | | |
| | | | 001289 | | 2/14/2024 | 166.06 | | |
| | | | 001289 | | 2/14/2024 | 33.22 | 2,223.79 | 2,223.79 |
| 0051336 | 0001215 | LAKE CITY TITLE | 001291 | | 2/14/2024 | 3,599.95 | | |
| | | | 001292 | | 2/14/2024 | 4,098.45 | | |
| | | | 001293 | | 2/14/2024 | 4,309.75 | | |
| | | | 001294 | | 2/14/2024 | 3,544.25 | | |
| | | | 001295 | | 2/14/2024 | 10,688.95 | | |
| | | | 001296 | | 2/14/2024 | 4,508.25 | | |
| | | | 001297 | | 2/14/2024 | 38,295.70 | | |
| | | | 001298 | | 2/14/2024 | 5,523.07 | | |
| | | | 001298 | | 2/14/2024 | 4,042.75 | | |
| | | | 001298 | | 2/14/2024 | 4,747.65 | | |
| | | | 001298 | | 2/14/2024 | 8,619.95 | 91,978.72 | 91,978.72 |
| 0051337 | 0006196 | LAURA NETTLES LLC | 001318 | | 2/14/2024 | 2,240.00 | | |
| | | | 001318 | | 2/14/2024 | 2,030.00 | 4,270.00 | 4,270.00 |
| 0051338 | 0004710 | LAWSON PRODUCTS, INC. | 3316 | P44464 | 2/14/2024 | 62.23 | 62.23 | 62.23 |
| 0051339 | 0003020 | LEVY JONES | 3265 | P45230 | 2/14/2024 | 239.35 | 239.35 | 239.35 |
| 0051340 | 0005422 | LINDA IVERY | 3481 | P45337 | 2/14/2024 | 558.00 | 558.00 | 558.00 |
| 0051341 | 0003774 | LIQUID ENVIRONMENTAL SOLU | PI3168 | 027261 | 2/14/2024 | 976.34 | | |
| | | | PI3169 | 027261 | 2/14/2024 | 981.52 | | |
| | | | PI3170 | 027261 | 2/14/2024 | 1,001.80 | | |
| | | | PI3171 | 027261 | 2/14/2024 | 1,047.48 | | |
| | | | PI3172 | 027261 | 2/14/2024 | 993.99 | | |
| | | | PI3173 | 027261 | 2/14/2024 | 991.50 | | |
| | | | PI3174 | 027261 | 2/14/2024 | 1,044.04 | | |
| | | | PI3175 | 027261 | 2/14/2024 | 1,059.80 | | |
| | | | PI3176 | 027261 | 2/14/2024 | 981.91 | | |
| | | | PI3177 | 027261 | 2/14/2024 | 981.52 | | |
| | | | PI3178 | 027261 | 2/14/2024 | 968.29 | | |
| | | | PI3179 | 027261 | 2/14/2024 | 1,051.55 | | |
| | | | PI3180 | 027261 | 2/14/2024 | 1,052.31 | | |
| | | | PI3181 | 027261 | 2/14/2024 | 976.54 | | |
| | | | PI3182 | 027261 | 2/14/2024 | 974.23 | | |
| | | | PI3183 | 027261 | 2/14/2024 | 1,006.66 | 16,089.48 | 16,089.48 |
| 0051342 | 0005903 | LIVE OAK INVESTMENTS | 14153503 | P45432 | 2/14/2024 | 2,752.00 | 2,752.00 | 2,752.00 |
| 0051343 | 0006078 | LOCKLEAR & ASSOCIATES, IN | 001318 | | 2/14/2024 | 35,625.00 | 35,625.00 | 35,625.00 |
| 0051344 | 0001262 | LOWE'S PROX | 3211 | P45106 | 2/14/2024 | 11.08 | | |
| | | | 3228 | P45113 | 2/14/2024 | 128.21 | | |
| | | | 3255 | P45081 | 2/14/2024 | 45.72 | | |
| | | | 3433 | P45158 | 2/14/2024 | 80.57 | | |
| | | | 3509 | P45438 | 2/14/2024 | 29.78 | 295.36 | 295.36 |
| 0051345 | 0001216 | LUBE SPECIALISTS | 3340 | P44944 | 2/14/2024 | 130.60 | | |

| CHECK NO | VENDOR NO | VENDOR NAME | VOUCHER NO | P.O. NO | DATE | VOUCHER AMOUNT | REMITTANCE AMOUNT | CHECK TOTAL |
|----------|-----------|---------------------------|------------|---------|-----------|----------------|-------------------|-------------|
| 0051345 | 0001216 | LUBE SPECIALISTS | 3378 | P45248 | 2/14/2024 | 19.33 | | |
| | | | 3466 | P45413 | 2/14/2024 | 64.63 | 214.56 | 214.56 |
| 0051346 | 0006272 | MARILYN FRAZIER | 3493 | P45371 | 2/14/2024 | 450.00 | 450.00 | 450.00 |
| 0051347 | 0003135 | MAYO FERTILIZER, INC. | 3351 | P45043 | 2/14/2024 | 38.00 | 38.00 | 38.00 |
| 0051348 | 0001319 | MCCRIMON'S OFFICE SUPPLY | 001277 | | 2/14/2024 | 219.49 | | |
| | | | 001277 | | 2/14/2024 | 71.42 | | |
| | | | 001277 | | 2/14/2024 | 34.84 | | |
| | | | 001318 | | 2/14/2024 | 221.15 | | |
| | | | 3279 | P45164 | 2/14/2024 | 46.96 | 593.86 | 593.86 |
| 0051349 | 0001351 | METAL MASTERS OF FLORIDA | 3194 | P45123 | 2/14/2024 | 97.35 | 97.35 | 97.35 |
| 0051350 | 0004503 | METZ,HUSBAND& DAUGHTON,P. | 001318 | | 2/14/2024 | 7,015.00 | 7,015.00 | 7,015.00 |
| 0051351 | 0001329 | MIDWEST TAPE EXCHANGE | PI3113 | 027083 | 2/14/2024 | 6.94 | | |
| | | | PI3140 | 027083 | 2/14/2024 | 57.57 | 64.51 | 64.51 |
| 0051352 | 0001346 | MIKELL'S POWER EQUIPMENT | 3483 | P45375 | 2/14/2024 | 845.95 | 845.95 | 845.95 |
| 0051353 | 0006050 | MOWREY ELEVATOR COMPANY | O3444 | P45402 | 2/14/2024 | 110.00 | | |
| | | | 3445 | P45403 | 2/14/2024 | 110.00 | | |
| | | | 3446 | P45404 | 2/14/2024 | 110.00 | | |
| | | | 3447 | P45405 | 2/14/2024 | 110.00 | | |
| | | | 3448 | P45406 | 2/14/2024 | 110.00 | 550.00 | 550.00 |
| 0051354 | 0001395 | MUSCO SPORTS LIGHTING, LL | PI3153 | 027103 | 2/14/2024 | 83,017.00 | | |
| | | | PI3164 | 027103 | 2/14/2024 | 104,983.00 | 188,000.00 | 188,000.00 |
| 0051355 | 0001435 | NABORS, GIBLIN & NICKERSO | 001354 | | 2/14/2024 | 90.00 | | |
| | | | 001354 | | 2/14/2024 | 1,260.00 | 1,350.00 | 1,350.00 |
| 0051356 | 0001434 | NE-RO TIRE & BRAKE SERVIC | 3333 | P44958 | 2/14/2024 | 464.00 | 464.00 | 464.00 |
| 0051357 | 0004840 | NETTING PROFESSIONALS, LL | PI3166 | 027188 | 2/14/2024 | 12,550.00 | 12,550.00 | 12,550.00 |
| 0051358 | 0001429 | NEXTRAN TRUCK CENTER | 3271 | P45069 | 2/14/2024 | 166.56 | | |
| | | | 3296 | P45203 | 2/14/2024 | 239.74 | 406.30 | 406.30 |
| 0051359 | 0001194 | NFPA | 3196 | P45226 | 2/14/2024 | 175.00 | | |
| | | | 3377 | P45228 | 2/14/2024 | 1,552.50 | 1,727.50 | 1,727.50 |
| 0051360 | 0003173 | NICOLE E. CALLUM | 3480 | P45336 | 2/14/2024 | 360.00 | 360.00 | 360.00 |
| 0051361 | 0001681 | NORTH FLORIDA SEPTIC TANK | 3303 | P45237 | 2/14/2024 | 350.00 | 350.00 | 350.00 |
| 0051362 | 0006029 | ODP BUSINESS SOLUTIONS, L | 3243 | P45094 | 2/14/2024 | 66.77 | | |
| | | | 3257 | P45096 | 2/14/2024 | 18.16 | | |
| | | | 3258 | P45096 | 2/14/2024 | 23.10 | | |
| | | | 3259 | P45096 | 2/14/2024 | 272.39 | | |
| | | | 3260 | P45096 | 2/14/2024 | 23.10 | | |
| | | | 3261 | P45096 | 2/14/2024 | 6.99 | | |
| | | | 3282 | P45146 | 2/14/2024 | 66.77 | | |
| | | | 3289 | P45170 | 2/14/2024 | 35.69 | | |
| | | | 3290 | P45175 | 2/14/2024 | 14.99 | | |
| | | | 3299 | P45179 | 2/14/2024 | 590.63 | | |
| | | | 3300 | P45180 | 2/14/2024 | 48.98 | | |
| | | | 3310 | P45188 | 2/14/2024 | 448.82 | | |
| | | | 3311 | P45189 | 2/14/2024 | 207.38 | | |
| | | | 3339 | P44383 | 2/14/2024 | 77.98 | | |
| | | | 3354 | P45259 | 2/14/2024 | 52.99 | | |
| | | | 3355 | P45049 | 2/14/2024 | 391.30 | | |
| | | | 3389 | P45260 | 2/14/2024 | 21.50 | | |
| | | | 3390 | P45260 | 2/14/2024 | 17.89 | | |
| | | | 3391 | P45260 | 2/14/2024 | 5.29 | | |
| | | | 3422 | P45208 | 2/14/2024 | 74.98 | | |
| | | | 3451 | P45244 | 2/14/2024 | 27.38 | | |

| CHECK NO | VENDOR NO | VENDOR NAME | VOUCHER NO | P.O. NO | DATE | VOUCHER AMOUNT | REMITTANCE AMOUNT | CHECK TOTAL |
|----------|-----------|-----------------------------|------------|---------|-----------|----------------|-------------------|-------------|
| 0051362 | 0006029 | ODP BUSINESS SOLUTIONS, | L3452 | P45245 | 2/14/2024 | 519.96 | | |
| | | | 3510 | P45449 | 2/14/2024 | 86.67 | 3,099.71 | 3,099.71 |
| 0051363 | 0005864 | PARADISE ADVERTISING & MAPI | PI3154 | 027126 | 2/14/2024 | 7,666.67 | | |
| | | | PI3155 | 027126 | 2/14/2024 | 3,645.83 | | |
| | | | PI3156 | 027126 | 2/14/2024 | 4,375.00 | | |
| | | | PI3157 | 027126 | 2/14/2024 | 875.00 | | |
| | | | PI3158 | 027126 | 2/14/2024 | 10,345.74 | | |
| | | | PI3159 | 027126 | 2/14/2024 | 8,519.82 | | |
| | | | PI3160 | 027126 | 2/14/2024 | 116.47 | | |
| | | | PI3165 | 027126 | 2/14/2024 | 1,575.00 | 37,119.53 | 37,119.53 |
| 0051364 | 0005911 | PARKING BOXX CORP. | 3440 | P45330 | 2/14/2024 | 200.00 | 200.00 | 200.00 |
| 0051365 | 0006118 | PATRIOT RESPONSE GROUP, | L001318 | | 2/14/2024 | 41,370.00 | 41,370.00 | 41,370.00 |
| 0051366 | 0001707 | PELONI'S PUMPING | 3436 | P45317 | 2/14/2024 | 475.00 | 475.00 | 475.00 |
| 0051367 | 0001041 | PETE OLIN AUTO PARTS, INC | 3331 | P44950 | 2/14/2024 | 88.00 | | |
| | | | 3350 | P45015 | 2/14/2024 | 98.81 | | |
| | | | 3357 | P45076 | 2/14/2024 | 121.18 | | |
| | | | 3428 | P45372 | 2/14/2024 | 25.82 | 333.81 | 333.81 |
| 0051368 | 0005930 | POWERHOUSE PEST CONTROL | I3409 | P45359 | 2/14/2024 | 35.00 | | |
| | | | 3453 | P45284 | 2/14/2024 | 35.00 | | |
| | | | 3454 | P45285 | 2/14/2024 | 35.00 | | |
| | | | 3455 | P45286 | 2/14/2024 | 50.00 | | |
| | | | 3456 | P45287 | 2/14/2024 | 35.00 | | |
| | | | 3469 | P45292 | 2/14/2024 | 35.00 | 225.00 | 225.00 |
| 0051369 | 0002220 | PRECISION CHEMICALS | 3302 | P45231 | 2/14/2024 | 114.72 | | |
| | | | 3419 | P45293 | 2/14/2024 | 267.50 | 382.22 | 382.22 |
| 0051370 | 0001973 | PREFERRED GOVERNMENTAL | IN002501 | | 2/14/2024 | 95.59 | | |
| | | | 002503 | | 2/14/2024 | 10.72 | | |
| | | | 002504 | | 2/14/2024 | 117.14 | | |
| | | | 002505 | | 2/14/2024 | 1,586.69 | | |
| | | | 002506 | | 2/14/2024 | 6.38 | | |
| | | | 002507 | | 2/14/2024 | 111.87 | | |
| | | | 002508 | | 2/14/2024 | 230.07 | | |
| | | | 002509 | | 2/14/2024 | 12.59 | | |
| | | | 002511 | | 2/14/2024 | 32.98 | | |
| | | | 002512 | | 2/14/2024 | 2,152.95 | | |
| | | | 002513 | | 2/14/2024 | 3.34 | | |
| | | | 002514 | | 2/14/2024 | 151.29 | | |
| | | | 002515 | | 2/14/2024 | 6.85 | | |
| | | | 002516 | | 2/14/2024 | 4,197.19 | | |
| | | | 002517 | | 2/14/2024 | 2,200.16 | | |
| | | | 002518 | | 2/14/2024 | 1,937.41 | | |
| | | | 002519 | | 2/14/2024 | 1,575.97 | | |
| | | | 002520 | | 2/14/2024 | 1,826.30 | | |
| | | | 002521 | | 2/14/2024 | 209.33 | | |
| | | | 002522 | | 2/14/2024 | 1,669.04 | | |
| | | | 002523 | | 2/14/2024 | 3,900.82 | | |
| | | | 002524 | | 2/14/2024 | 2,521.77 | | |
| | | | 002525 | | 2/14/2024 | 11,280.23 | | |
| | | | 002526 | | 2/14/2024 | 47.03 | | |
| | | | 002527 | | 2/14/2024 | 764.64 | | |
| | | | 002529 | | 2/14/2024 | 22.84 | | |
| | | | 002530 | | 2/14/2024 | 10.78 | | |

PROGRAM GM344LR
COLUMBIA COUNTY
BANK 00

| CHECK NO | VENDOR NO | VENDOR NAME | VOUCHER NO | P.O. NO | DATE | VOUCHER AMOUNT | REMITTANCE AMOUNT | CHECK TOTAL |
|----------|-----------|----------------------------|------------|---------|-----------|----------------|-------------------|-------------|
| 0051370 | 0001973 | PREFERRED GOVERNMENTAL | IN002531 | | 2/14/2024 | 2.99 | | |
| | | | 002532 | | 2/14/2024 | 11.60 | | |
| | | | 002533 | | 2/14/2024 | 119.60 | | |
| | | | 002534 | | 2/14/2024 | 15.93 | | |
| | | | 002535 | | 2/14/2024 | 6.62 | | |
| | | | 002536 | | 2/14/2024 | 21.79 | | |
| | | | 002537 | | 2/14/2024 | 2,606.00 | | |
| | | | 002538 | | 2/14/2024 | 168.68 | | |
| | | | 000054 | | 2/14/2024 | 29.93 | | |
| | | | 000055 | | 2/14/2024 | 168.68 | | |
| | | | 000055 | | 2/14/2024 | 168.67 | | |
| | | | 000056 | | 2/14/2024 | 181.10 | | |
| | | | 000280 | | 2/14/2024 | 87.86 | 40,271.42 | 40,271.42 |
| 0051371 | 0004063 | PREMIER PAPER & JANITORIA | 3236 | P45010 | 2/14/2024 | 96.95 | | |
| | | | 3239 | P44904 | 2/14/2024 | 573.37 | | |
| | | | 3280 | P45234 | 2/14/2024 | 350.14 | | |
| | | | 3356 | P45052 | 2/14/2024 | 578.53 | | |
| | | | 3388 | P45220 | 2/14/2024 | 690.90 | | |
| | | | 3457 | P45321 | 2/14/2024 | 384.69 | | |
| | | | 3470 | P45328 | 2/14/2024 | 95.80 | 2,770.38 | 2,770.38 |
| 0051372 | 0001793 | PREMIER WATER & ENERGY | TE3364 | P45196 | 2/14/2024 | 568.37 | 568.37 | 568.37 |
| 0051373 | 0004345 | PRITCHETT TRUCKING, INC. | PI3136 | 027076 | 2/14/2024 | 1,645.00 | 1,645.00 | 1,645.00 |
| 0051374 | 0001183 | RELIABLE SHREDDING SERVIC | 3298 | P45213 | 2/14/2024 | 613.00 | 613.00 | 613.00 |
| 0051375 | 0003415 | RICHARDSON PAINT | 3386 | P45312 | 2/14/2024 | 16.50 | 16.50 | 16.50 |
| 0051376 | 0004644 | RICKY RESCUE TRAINING ACA | 3468 | P45291 | 2/14/2024 | 150.00 | 150.00 | 150.00 |
| 0051377 | 0001907 | RING POWER CORP. | 3345 | P45365 | 2/14/2024 | 32.35 | | |
| | | | 3349 | P44969 | 2/14/2024 | 903.46 | | |
| | | | 3373 | P45249 | 2/14/2024 | 54.46 | | |
| | | | 3404 | P45366 | 2/14/2024 | 78.32 | 1,068.59 | 1,068.59 |
| 0051378 | 0001911 | ROUNTREE-MOORE FORD | 3383 | P45171 | 2/14/2024 | 277.75 | 277.75 | 277.75 |
| 0051379 | 0006148 | RW GATE COMPANY, INC | PI3131 | 027070 | 2/14/2024 | 67,030.00 | | |
| | | | PI3132 | 027070 | 2/14/2024 | 8,790.00 | 75,820.00 | 75,820.00 |
| 0051380 | 0006220 | SAVECO NORTH AMERICA INC | PI3126 | 027074 | 2/14/2024 | 54,113.00 | 54,113.00 | 54,113.00 |
| 0051381 | 0006261 | NORTH CENTRAL EMS CORPORA | 3304 | P45247 | 2/14/2024 | 239.96 | | |
| | | | 3467 | P45290 | 2/14/2024 | 146.97 | 386.93 | 386.93 |
| 0051382 | 0003966 | SERVPRO OF COLUMBIA & SUW | 3392 | P45264 | 2/14/2024 | 899.90 | | |
| | | | 3399 | P45261 | 2/14/2024 | 899.90 | 1,799.80 | 1,799.80 |
| 0051383 | 0004796 | SHARP ELECTRONICS CORPORAP | PI3116 | 027228 | 2/14/2024 | 104.69 | | |
| | | | PI3186 | 027288 | 2/14/2024 | 83.13 | | |
| | | | 3434 | P45159 | 2/14/2024 | 110.64 | 298.46 | 298.46 |
| 0051384 | 0002021 | SHERWIN-WILLIAMS CO.STORE | 3200 | P44799 | 2/14/2024 | 92.42 | 92.42 | 92.42 |
| 0051385 | 0005397 | SIEMENS INDUSTRY, INC. | PI3121 | 027273 | 2/14/2024 | 29,448.50 | | |
| | | | 3213 | P45108 | 2/14/2024 | 443.20 | 29,891.70 | 29,891.70 |
| 0051386 | 0004477 | SNIFFEN & SPELLMAN, P.A. | 001319 | | 2/14/2024 | 2,250.00 | 2,250.00 | 2,250.00 |
| 0051387 | 0005026 | SOLITUDE LAKE MANAGEMENT | 3437 | P45318 | 2/14/2024 | 224.10 | | |
| | | | 3438 | P45319 | 2/14/2024 | 265.50 | | |
| | | | 3439 | P45320 | 2/14/2024 | 208.80 | 698.40 | 698.40 |
| 0051388 | 0004057 | SOUTHERN ECONOMIC DEVE. | C3274 | P45135 | 2/14/2024 | 300.00 | 300.00 | 300.00 |
| 0051389 | 0003610 | STANLEY CRAWFORD | 3502 | P45431 | 2/14/2024 | 3,831.33 | 3,831.33 | 3,831.33 |
| 0051390 | 0000005 | STONE, CHARIS AND BRIAN | 001277 | | 2/14/2024 | 200.00 | 200.00 | 200.00 |
| 0051391 | 0000814 | SUPERION, LLC | 001277 | | 2/14/2024 | 3,271.96 | | |
| | | | 001278 | | 2/14/2024 | 3,272.00 | | |

PROGRAM GM344LR
COLUMBIA COUNTY
BANK 00

| CHECK NO | VENDOR NO | VENDOR NAME | VOUCHER NO | P.O. NO | DATE | VOUCHER AMOUNT | REMITTANCE AMOUNT | CHECK TOTAL |
|----------|-----------|---------------------------|------------|---------|-----------|----------------|-------------------|-------------|
| 0051391 | 0000814 | SUPERION, LLC | 001318 | | 2/14/2024 | 3,599.20 | 10,143.16 | 10,143.16 |
| 0051392 | 0008512 | SUWANNEE RIVER ECONOMIC | C001318 | | 2/14/2024 | 12,750.00 | | |
| | | | 001319 | | 2/14/2024 | 14,400.00 | 27,150.00 | 27,150.00 |
| 0051393 | 0002078 | SWIFT LUBE | 3275 | P45136 | 2/14/2024 | 98.65 | 98.65 | 98.65 |
| 0051394 | 0006065 | SYNERGY DISASTER RECOVERY | 001277 | | 2/14/2024 | 16,730.00 | 16,730.00 | 16,730.00 |
| 0051395 | 0003848 | TARGET SOLUTIONS, INC. | DEPI3130 | 027251 | 2/14/2024 | 5,268.00 | 5,268.00 | 5,268.00 |
| 0051396 | 0005511 | TEP OPCO, LLC | PI3185 | 027283 | 2/14/2024 | 2,750.00 | | |
| | | | 3193 | P45223 | 2/14/2024 | 250.00 | | |
| | | | 3314 | P45221 | 2/14/2024 | 1,500.00 | | |
| | | | 3317 | P45219 | 2/14/2024 | 1,500.00 | 6,000.00 | 6,000.00 |
| 0051397 | 0005848 | TERRAGREEN LLC | PI3151 | 027099 | 2/14/2024 | 875.00 | 875.00 | 875.00 |
| 0051398 | 0004372 | TESSCO INCORPORATED | 3264 | P45218 | 2/14/2024 | 79.08 | 79.08 | 79.08 |
| 0051399 | 0006023 | THE ADT SECURITY CORPORAT | 3508 | P45437 | 2/14/2024 | 212.82 | 212.82 | 212.82 |
| 0051400 | 0000625 | GANNETT HOLDINGS-SOUTHEAS | 3195 | P45147 | 2/14/2024 | 893.00 | 893.00 | 893.00 |
| 0051401 | 0005203 | THE LAW OFFICE OF JOEL F. | 001277 | | 2/14/2024 | 1,650.00 | 1,650.00 | 1,650.00 |
| 0051402 | 0003850 | TIMMY HALL'S APPLIANCE SE | 3450 | P45288 | 2/14/2024 | 125.00 | 125.00 | 125.00 |
| 0051403 | 0006268 | TOWN SQUARE PUBLICATIONS | 3460 | P45266 | 2/14/2024 | 499.00 | 499.00 | 499.00 |
| 0051404 | 0004627 | TRANE US, INC. | PI3411 | 027262 | 2/14/2024 | 2,598.96 | | |
| | | | PI3412 | 027262 | 2/14/2024 | 4,483.50 | 7,082.46 | 7,082.46 |
| 0051405 | 0001667 | TRANSPORTATION CONTROL SY | 3387 | P43943 | 2/14/2024 | 300.00 | | |
| | | | 3398 | P45369 | 2/14/2024 | 498.00 | 798.00 | 798.00 |
| 0051406 | 0005958 | TWINBERRY FARMS LLC | 3248 | P45054 | 2/14/2024 | 93.15 | | |
| | | | 3405 | P45299 | 2/14/2024 | 558.90 | 652.05 | 652.05 |
| 0051407 | 0005157 | TWO FOLD WATER ENGINEERIN | 3315 | P45347 | 2/14/2024 | 1,468.00 | | |
| | | | 3380 | P45350 | 2/14/2024 | 1,400.00 | | |
| | | | 3381 | P45351 | 2/14/2024 | 1,475.00 | 4,343.00 | 4,343.00 |
| 0051408 | 0003989 | UNIFIRST CORPORATION | 3227 | P45112 | 2/14/2024 | 70.37 | | |
| | | | 3229 | P45114 | 2/14/2024 | 173.21 | | |
| | | | 3240 | P45006 | 2/14/2024 | 14.99 | | |
| | | | 3241 | P45009 | 2/14/2024 | 56.40 | | |
| | | | 3249 | P45061 | 2/14/2024 | 70.37 | | |
| | | | 3250 | P45062 | 2/14/2024 | 173.21 | | |
| | | | 3278 | P45163 | 2/14/2024 | 16.62 | | |
| | | | 3293 | P45155 | 2/14/2024 | 101.73 | | |
| | | | 3294 | P45162 | 2/14/2024 | 29.80 | | |
| | | | 3295 | P45176 | 2/14/2024 | 47.40 | | |
| | | | 3297 | P45205 | 2/14/2024 | 14.99 | | |
| | | | 3319 | P45345 | 2/14/2024 | 595.94 | | |
| | | | 3352 | P45056 | 2/14/2024 | 39.97 | | |
| | | | 3393 | P45303 | 2/14/2024 | 173.21 | | |
| | | | 3394 | P45304 | 2/14/2024 | 70.37 | | |
| | | | 3397 | P45346 | 2/14/2024 | 838.42 | | |
| | | | 3408 | P45358 | 2/14/2024 | 29.68 | | |
| | | | 3410 | P45364 | 2/14/2024 | 101.73 | | |
| | | | 3427 | P45315 | 2/14/2024 | 155.87 | | |
| | | | 3458 | P45322 | 2/14/2024 | 76.98 | | |
| | | | 3491 | P45448 | 2/14/2024 | 54.95 | 2,906.21 | 2,906.21 |
| 0051409 | 0004909 | UNITED REFRIGERATION, INC | 3207 | P45102 | 2/14/2024 | 20.79 | | |
| | | | 3208 | P45103 | 2/14/2024 | 90.76 | | |
| | | | 3209 | P45104 | 2/14/2024 | 90.76 | | |
| | | | 3210 | P45105 | 2/14/2024 | 181.52 | | |
| | | | 3214 | P45109 | 2/14/2024 | 181.52 | | |

| CHECK NO | VENDOR NO | VENDOR NAME | VOUCHER NO | P.O. NO | DATE | VOUCHER AMOUNT | REMITTANCE AMOUNT | CHECK TOTAL |
|----------|-----------|---------------------------|------------|---------|-----------|----------------|-------------------|--------------|
| 0051409 | 0004909 | UNITED REFRIGERATION, INC | 3216 | P45128 | 2/14/2024 | 90.76 | | |
| | | | 3217 | P45128 | 2/14/2024 | 90.76 | | |
| | | | 3218 | P45128 | 2/14/2024 | 90.76 | | |
| | | | 3219 | P45128 | 2/14/2024 | 90.76 | | |
| | | | 3220 | P45128 | 2/14/2024 | 90.76 | | |
| | | | 3221 | P45128 | 2/14/2024 | 90.76 | | |
| | | | 3222 | P45128 | 2/14/2024 | 90.76 | | |
| | | | 3223 | P45128 | 2/14/2024 | 90.76 | | |
| | | | 3234 | P45118 | 2/14/2024 | 366.67 | | |
| | | | 3238 | P45125 | 2/14/2024 | 156.91 | | |
| | | | 3244 | P45120 | 2/14/2024 | 158.48 | | |
| | | | 3252 | P45071 | 2/14/2024 | 518.31 | | |
| | | | 3253 | P45072 | 2/14/2024 | 152.40 | | |
| | | | 3385 | P45311 | 2/14/2024 | 10.33 | 2,654.53 | 2,654.53 |
| 0051410 | 0001152 | WASTE PRO - LAKE CITY | 001318 | | 2/14/2024 | 4,446.08 | 4,446.08 | 4,446.08 |
| 0051411 | 0006043 | WHARTON-SMITH, INC. | PI3120 | 027271 | 2/14/2024 | 971,078.63 | 971,078.63 | 971,078.63 |
| 0051412 | 0002462 | WHITEHEAD HARDWARE COMPAN | 3366 | P44643 | 2/14/2024 | 748.60 | | |
| | | | 3384 | P45200 | 2/14/2024 | 599.00 | 1,347.60 | 1,347.60 |
| 0051413 | 0000129 | WINDSTREAM | 001250 | | 2/14/2024 | 190.27 | | |
| | | | 001250 | | 2/14/2024 | 77.95 | | |
| | | | 001250 | | 2/14/2024 | 154.08 | | |
| | | | 3263 | P45165 | 2/14/2024 | 160.60 | 582.90 | 582.90 |
| 0051414 | 0005973 | WINDSTREAM | 3501 | P45429 | 2/14/2024 | 410.48 | 410.48 | 410.48 |
| 0051415 | 0003387 | WINDSTREAM . 2 | 3500 | P45427 | 2/14/2024 | 185.19 | 185.19 | 185.19 |
| 0051416 | 0005190 | WINSUPPLY | 3191 | P37190 | 2/14/2024 | 70.62 | | |
| | | | 3202 | P45087 | 2/14/2024 | 37.19 | | |
| | | | 3254 | P45073 | 2/14/2024 | 57.48 | | |
| | | | 3396 | P45309 | 2/14/2024 | 48.90 | | |
| | | | 3459 | P45376 | 2/14/2024 | 16.07 | | |
| | | | 3471 | P45332 | 2/14/2024 | 111.78 | 342.04 | 342.04 |
| 0051417 | 0005474 | 3RD ALARM PUBLIC SAFETY | T3267 | P45233 | 2/14/2024 | 600.00 | 600.00 | 600.00 |
| | | | | | | TOTAL CHECKS | 185 | 3,757,518.28 |



**COLUMBIA COUNTY BOARD OF COUNTY COMMISSIONERS
AGENDA ITEM REQUEST FORM**

The Board of County Commissioners meets the 1st and 3rd Thursday of each month in the Columbia County School Board Administrative Complex Auditorium, 372 West Duval Street, Lake City, Florida 32055. The first meeting of every month is at 9:30AM while the second meeting of every month takes place at 5:30PM. All agenda items are due in the Board's office one week prior to the meeting date.

Today's Date: 2/15/2024 Meeting Date: 3/7/2024

Department: BCC Administration

1. Nature and purpose of agenda item:

This item requests Board approval for the payment of bills and vouchers in the amount of \$100 submitted 2/15/24. All funds authorized for the issuance of these checks have been budgeted. The Clerk to Board office reviews bills and vouchers submitted for approval. If for any reason, any of these bills are not recommended for approval, the Clerk to Board office will notify the Board. Copies of invoices and supporting documentation are maintained in the Clerk to Board office for review.

2. Recommended Motion/Action:

Approve payment of bills and vouchers in the amount of \$100.00

3. Fiscal impact on current budget.

This item has no effect on the current budget.

COLUMBIA COUNTY BOARD OF COMMISSIONERS ACCOUNTS PAYABLE CHECK REGISTER

| Check Date | Beginning Check Number | Ending Check Number | Number of Checks | Positive Pay File Upload Date | Check Register Total |
|------------|----------------------------------|---------------------|------------------|-------------------------------|----------------------|
| 2/15/2024 | 51418 | 51418 | 1 | 2/15/2024 | \$100.00 |
| | | | | | |
| | | | | | |
| | | | | | |
| | | | | | |
| | | | | | |
| | | | | | |
| | TOTAL CHECKS & AMOUNT | | 1 | | \$100.00 |

| CHECK NO | VENDOR NO | VENDOR NAME | VOUCHER NO | P.O. NO | DATE | VOUCHER AMOUNT | REMITTANCE AMOUNT | CHECK TOTAL |
|----------|-----------|----------------------|------------|---------|-----------|----------------|-------------------|-------------|
| 0051418 | 0002075 | SUWANNEE RIVER WATER | MGMT001453 | | 2/15/2024 | 100.00 | 100.00 | 100.00 |
| | | | | | | TOTAL CHECKS | 1 | 100.00 |



**COLUMBIA COUNTY BOARD OF COUNTY COMMISSIONERS
AGENDA ITEM REQUEST FORM**

The Board of County Commissioners meets the 1st and 3rd Thursday of each month in the Columbia County School Board Administrative Complex Auditorium, 372 West Duval Street, Lake City, Florida 32055. The first meeting of every month is at 9:30AM while the second meeting of every month takes place at 5:30PM. All agenda items are due in the Board's office one week prior to the meeting date.

Today's Date: 2/29/2024 Meeting Date: 3/7/2024

Department: Finance

1. Nature and purpose of agenda item:

This item requests Board approval for the payment of bills and vouchers in the amount of \$3,046,331.40 submitted 2/28/24. All funds authorized for the issuance of these checks have been budgeted. The Clerk to the Board office reviews bills and vouchers submitted for approval. If for any reason, any of these bills are not recommended for approval, the Clerk to Board office will notify the Board. The Clerk to the Board office maintains copies of invoices and supporting documentation for review.

2. Recommended Motion/Action:

Approve payment of bills and vouchers in the amount of \$3,046,331.40

3. Fiscal impact on current budget.

This item has no effect on the current budget.

COLUMBIA COUNTY BOARD OF COMMISSIONERS ACCOUNTS PAYABLE CHECK REGISTER

| Check Date | Beginning Check Number | Ending Check Number | Number of Checks | Positive Pay File Upload Date | Check Register Total |
|------------|----------------------------------|---------------------|------------------|-------------------------------|-----------------------|
| 2/28/2024 | 51419 | 51583 | 165 | 2/28/2024 | \$3,046,331.40 |
| | | | | | |
| | | | | | |
| | | | | | |
| | | | | | |
| | | | | | |
| | | | | | |
| | TOTAL CHECKS & AMOUNT | | 165 | | \$3,046,331.40 |

PROGRAM GM344LR
COLUMBIA COUNTY
BANK 00

| CHECK NO | VENDOR NO | VENDOR NAME | VOUCHER NO | P.O. NO | DATE | VOUCHER AMOUNT | REMITTANCE AMOUNT | CHECK TOTAL |
|----------|-----------|----------------------------|------------|---------|-----------|----------------|-------------------|-------------|
| 0051419 | 0002013 | A T & T | 001526 | | 2/28/2024 | 349.95 | 349.95 | 349.95 |
| 0051420 | 0006049 | ACF STANDBY SYSTEMS, LLC | 3737 | P45635 | 2/28/2024 | 199.00 | 199.00 | 199.00 |
| 0051421 | 0000185 | ACTION SIGNS & GRAPHICS, | 3773 | P45782 | 2/28/2024 | 262.15 | 262.15 | 262.15 |
| 0051422 | 0001207 | ADVANCE AUTO PARTS | 3566 | P45340 | 2/28/2024 | 390.39 | | |
| | | | 3567 | P45341 | 2/28/2024 | 90.02 | | |
| | | | 3568 | P45344 | 2/28/2024 | 45.71 | 526.12 | 526.12 |
| 0051423 | 0004792 | AG-PRO LAKE CITY | 3559 | P45269 | 2/28/2024 | 474.28 | 474.28 | 474.28 |
| 0051424 | 0005537 | AHS-GEAR, LLC | PI3710 | 027294 | 2/28/2024 | 368.18 | 368.18 | 368.18 |
| 0051425 | 0002807 | ALTEC INDUSTRIES, INC. | 3553 | P45169 | 2/28/2024 | 718.37 | 718.37 | 718.37 |
| 0051426 | 0003894 | AMERICAN PIPE AND TANK, I | 3572 | P45495 | 2/28/2024 | 2,098.00 | | |
| | | | 3573 | P45496 | 2/28/2024 | 2,098.00 | | |
| | | | 3574 | P45497 | 2/28/2024 | 2,098.00 | 6,294.00 | 6,294.00 |
| 0051427 | 0001844 | AMERICAN TRANSMISSION, INC | 1845 | | 2/28/2024 | 269.98 | 269.98 | 269.98 |
| 0051428 | 0000111 | ANDERSON COLUMBIA CO., IN | 3549 | P45580 | 2/28/2024 | 778.80 | | |
| | | | 3571 | P45581 | 2/28/2024 | 333.30 | | |
| | | | 001534 | | 2/28/2024 | 482,419.84 | | |
| | | | 3730 | P45734 | 2/28/2024 | 361.90 | 483,893.84 | 483,893.84 |
| 0051429 | 0006259 | ARRIVE ALIVE TRAFFIC CONT | PI3523 | 027248 | 2/28/2024 | 14,993.75 | 14,993.75 | 14,993.75 |
| 0051430 | 0003368 | AT & T | 001482 | | 2/28/2024 | 2,025.47 | | |
| | | | 001498 | | 2/28/2024 | 2,928.59 | 4,954.06 | 4,954.06 |
| 0051431 | 0006208 | A2B DEVELOPMENT LLC | 001501 | | 2/28/2024 | 61,335.00 | 61,335.00 | 61,335.00 |
| 0051432 | 0000218 | BAKER & TAYLOR BOOKS | PI3512 | 027080 | 2/28/2024 | 64.04 | | |
| | | | PI3513 | 027081 | 2/28/2024 | 102.97 | | |
| | | | PI3514 | 027082 | 2/28/2024 | 18.25 | | |
| | | | PI3517 | 027089 | 2/28/2024 | 143.59 | | |
| | | | 3561 | P45445 | 2/28/2024 | 5.00- | | |
| | | | PI3699 | 027080 | 2/28/2024 | 970.95 | | |
| | | | PI3700 | 027081 | 2/28/2024 | 336.17 | | |
| | | | PI3701 | 027082 | 2/28/2024 | 164.94 | | |
| | | | PI3702 | 027085 | 2/28/2024 | 267.53 | | |
| | | | PI3703 | 027089 | 2/28/2024 | 3,438.82 | 5,502.26 | 5,502.26 |
| 0051433 | 0000251 | BAKER DISTRIBUTING CO. | 3732 | P45702 | 2/28/2024 | 30.09 | | |
| | | | 3747 | P45692 | 2/28/2024 | 163.32 | 193.41 | 193.41 |
| 0051434 | 0000211 | BAYA URGENT CARE LLC | 001500 | | 2/28/2024 | 70.00 | 70.00 | 70.00 |
| 0051435 | 0004015 | BAYWAY SERVICE | 3770 | P45776 | 2/28/2024 | 325.00 | 325.00 | 325.00 |
| 0051436 | 0003643 | BEARD EQUIPMENT CO. INC. | 3532 | P37690 | 2/28/2024 | 311.70 | | |
| | | | 3595 | P45541 | 2/28/2024 | 853.75 | | |
| | | | PI3708 | 027292 | 2/28/2024 | 3,101.62 | 4,267.07 | 4,267.07 |
| 0051437 | 0004746 | BEAVER BULK, INC. | PI3521 | 027196 | 2/28/2024 | 9,262.08 | | |
| | | | PI3707 | 027196 | 2/28/2024 | 2,969.66 | 12,231.74 | 12,231.74 |
| 0051438 | 0004050 | BENTLEY SYSTEM, INC. | 001535 | | 2/28/2024 | 3,542.82 | 3,542.82 | 3,542.82 |
| 0051439 | 0000250 | BEST PLUMBING SPECIALTIES | 3735 | P45593 | 2/28/2024 | 468.24 | 468.24 | 468.24 |
| 0051440 | 0000221 | BRODART CO. | 3554 | P45444 | 2/28/2024 | 47.83 | 47.83 | 47.83 |
| 0051441 | 0004636 | C & C DISCOUNT PARTS | 3726 | P45589 | 2/28/2024 | 1,575.00 | 1,575.00 | 1,575.00 |
| 0051442 | 0005907 | CA FLORIDA HOLDINGS, LLC | 3531 | P45485 | 2/28/2024 | 683.10 | 683.10 | 683.10 |
| 0051443 | 0008080 | CAL-TECH TESTINGS, INC. | 001552 | | 2/28/2024 | 3,695.00 | 3,695.00 | 3,695.00 |
| 0051444 | 0005110 | CANDLER MOSES & ASSOCIATE | 001472 | | 2/28/2024 | 2,500.00 | | |
| | | | 001473 | | 2/28/2024 | 450.00 | | |
| | | | 001474 | | 2/28/2024 | 2,000.00 | 4,950.00 | 4,950.00 |
| 0051445 | 0001796 | CAROLYN HEIGHTS WATER CO. | 3693 | P45637 | 2/28/2024 | 59.00 | | |
| | | | 3728 | P45681 | 2/28/2024 | 181.18 | | |
| | | | 3753 | P45640 | 2/28/2024 | 148.24 | 388.42 | 388.42 |

| CHECK NO | VENDOR NO | VENDOR NAME | VOUCHER NO | P.O. NO | DATE | VOUCHER AMOUNT | REMITTANCE AMOUNT | CHECK TOTAL |
|----------|-----------|---------------------------|------------|---------|-----------|----------------|-------------------|--------------|
| 0051446 | 0000345 | CINTAS CORPORATION | 3725 | P45722 | 2/28/2024 | 43.99 | 43.99 | 43.99 |
| 0051447 | 0000382 | CITY ELECTRIC SUPPLY, INC | 3536 | P45511 | 2/28/2024 | 97.85 | | |
| | | | 3560 | P45276 | 2/28/2024 | 43.64 | | |
| | | | 3570 | P45575 | 2/28/2024 | 7.76 | | |
| | | | 3578 | P45574 | 2/28/2024 | 41.20 | | |
| | | | 3579 | P45576 | 2/28/2024 | 235.12 | | |
| | | | 3684 | P45602 | 2/28/2024 | 11.80 | | |
| | | | 1665 | | 2/28/2024 | 23.28 | | |
| | | | 1857 | | 2/28/2024 | 84.00 | | |
| | | | 3729 | P45704 | 2/28/2024 | 195.50 | 740.15 | 740.15 |
| 0051448 | 0000304 | CITY OF LAKE CITY - UTILI | 001461 | | 2/28/2024 | 691.81 | | |
| | | | 001462 | | 2/28/2024 | 181.07 | | |
| | | | 001463 | | 2/28/2024 | 17,211.73 | | |
| | | | 001464 | | 2/28/2024 | 656.50 | | |
| | | | 001465 | | 2/28/2024 | 83.29 | | |
| | | | 001466 | | 2/28/2024 | 200.55 | | |
| | | | 001467 | | 2/28/2024 | 800.94 | | |
| | | | 001468 | | 2/28/2024 | 624.09 | | |
| | | | 001469 | | 2/28/2024 | 2,485.92 | | |
| | | | 001470 | | 2/28/2024 | 24.07 | | |
| | | | 001516 | | 2/28/2024 | 814.47 | | |
| | | | 001517 | | 2/28/2024 | 157.12 | | |
| | | | 001518 | | 2/28/2024 | 88.42 | | |
| | | | 001519 | | 2/28/2024 | 234.29 | | |
| | | | 001520 | | 2/28/2024 | 69.96 | | |
| | | | 001521 | | 2/28/2024 | 315.59 | | |
| | | | 001522 | | 2/28/2024 | 122.10 | | |
| | | | 001523 | | 2/28/2024 | 568.50 | | |
| | | | 001524 | | 2/28/2024 | 540.86 | | |
| | | | 001525 | | 2/28/2024 | 33.59 | | |
| | | | 3767 | P45771 | 2/28/2024 | 73.99 | 25,978.86 | 25,978.86 |
| 0051449 | 0000308 | CLAY ELECTRIC COOPERATIVE | 000153 | | 2/28/2024 | 396.35 | | |
| | | | 000154 | | 2/28/2024 | 118.69 | | |
| | | | 000155 | | 2/28/2024 | 7,501.13 | | |
| | | | 000156 | | 2/28/2024 | 3,862.75 | | |
| | | | 000157 | | 2/28/2024 | 1,222.15 | | |
| | | | 000158 | | 2/28/2024 | 592.50 | | |
| | | | 000159 | | 2/28/2024 | 1,738.25 | | |
| | | | 000160 | | 2/28/2024 | 78.00 | 15,509.82 | 15,509.82 |
| 0051450 | 0000352 | CLERK OF COURT COLUMBIA C | 3838 | P45795 | 2/28/2024 | 27.70 | 27.70 | 27.70 |
| 0051451 | 0003677 | COBURN AND ASSOCIATES INC | PI3672 | 027297 | 2/28/2024 | 8,800.00 | 8,800.00 | 8,800.00 |
| 0051452 | 0002087 | COLUMBIA COUNTY ELECTIONS | 001584 | | 2/28/2024 | 116,925.36 | 116,925.36 | 116,925.36 |
| 0051453 | 0002039 | SHERIFF COLUMBIA COUNTY | 001481 | | 2/28/2024 | 1,706,571.00 | 1,706,571.00 | 1,706,571.00 |
| 0051454 | 0003042 | COLUMBIA COUNTY TAX COLLE | 001475 | | 2/28/2024 | 85.75 | | |
| | | | 001476 | | 2/28/2024 | 85.75 | 171.50 | 171.50 |
| 0051455 | 0002822 | COMCAST,GRP-1 | 001498 | | 2/28/2024 | 142.26 | | |
| | | | 001498 | | 2/28/2024 | 142.26 | 284.52 | 284.52 |
| 0051456 | 0002822 | COMCAST,GRP-2 | 001498 | | 2/28/2024 | 269.57 | 269.57 | 269.57 |
| 0051457 | 0004830 | COMCAST CABLE COMMUNICATI | 3765 | P45668 | 2/28/2024 | 10.00 | 10.00 | 10.00 |
| 0051458 | 0006257 | COOK, DANA DANIELLE | 000705 | | 2/28/2024 | 175.00 | | |
| | | | 000706 | | 2/28/2024 | 66.74- | 108.26 | 108.26 |
| 0051459 | 0001650 | COOPER FUNERAL HOME | 001502 | | 2/28/2024 | 400.00 | 400.00 | 400.00 |

PROGRAM GM344LR
COLUMBIA COUNTY
BANK 00

| CHECK NO | VENDOR NO | VENDOR NAME | VOUCHER NO | P.O. NO | DATE | VOUCHER AMOUNT | REMITTANCE AMOUNT | CHECK TOTAL |
|----------|-----------|---------------------------|------------|---------|-----------|----------------|-------------------|-------------|
| 0051460 | 0004609 | COX FIRE PROTECTION, INC. | 3581 | P45515 | 2/28/2024 | 110.00 | | |
| | | | 3582 | P45516 | 2/28/2024 | 90.00 | | |
| | | | 3583 | P45517 | 2/28/2024 | 90.00 | | |
| | | | 3584 | P45518 | 2/28/2024 | 110.00 | 400.00 | 400.00 |
| 0051461 | 0004846 | CREATIVE CONCRETE DESIGN | PI3711 | 027299 | 2/28/2024 | 4,807.58 | 4,807.58 | 4,807.58 |
| 0051462 | 0001687 | CURT'S CONSTRUCTION, INC. | 001551 | | 2/28/2024 | 16,232.27 | 16,232.27 | 16,232.27 |
| 0051463 | 0004148 | DAVE SYMONDS & ASSOCIATES | 3724 | P45712 | 2/28/2024 | 624.04 | 624.04 | 624.04 |
| 0051464 | 0000440 | DELL MARKETING L.P. | 3771 | P45780 | 2/28/2024 | 4,104.94 | | |
| | | | 3772 | P45781 | 2/28/2024 | 2,117.34 | 6,222.28 | 6,222.28 |
| 0051465 | 0000415 | DEMCO, INC | 3562 | P45468 | 2/28/2024 | 204.96 | 204.96 | 204.96 |
| 0051466 | 0005225 | DEWBERRY ENGINEERS, INC. | PI3706 | 027178 | 2/28/2024 | 5,531.03 | 5,531.03 | 5,531.03 |
| 0051467 | 0004392 | DMS DIVISION OF TELECOMMU | 001483 | | 2/28/2024 | 122.15 | | |
| | | | 001484 | | 2/28/2024 | 268.73 | | |
| | | | 001485 | | 2/28/2024 | 2,763.60 | 3,154.48 | 3,154.48 |
| 0051468 | 0000615 | DUKE ENERGY | 001488 | | 2/28/2024 | 739.64 | | |
| | | | 001489 | | 2/28/2024 | 118.13 | | |
| | | | 001490 | | 2/28/2024 | 766.63 | | |
| | | | 001491 | | 2/28/2024 | 390.27 | | |
| | | | 001492 | | 2/28/2024 | 249.28 | | |
| | | | 001493 | | 2/28/2024 | 30.79 | | |
| | | | 001494 | | 2/28/2024 | 457.20 | | |
| | | | 001495 | | 2/28/2024 | 393.31 | | |
| | | | 001496 | | 2/28/2024 | 784.34 | | |
| | | | 001527 | | 2/28/2024 | 271.77 | | |
| | | | 001528 | | 2/28/2024 | 148.81 | | |
| | | | 001529 | | 2/28/2024 | 32.02 | | |
| | | | 001530 | | 2/28/2024 | 18.31 | | |
| | | | 001531 | | 2/28/2024 | 34.03 | | |
| | | | 001532 | | 2/28/2024 | 17.80 | 4,452.33 | 4,452.33 |
| 0051469 | 0000534 | EVACHEK'S TREE SERVICE | 3720 | P45735 | 2/28/2024 | 130.00 | 130.00 | 130.00 |
| 0051470 | 0006071 | FERREIRA FUNERAL SERVICES | 001503 | | 2/28/2024 | 450.00 | 450.00 | 450.00 |
| 0051471 | 0003438 | FLORIDA CATTLEMEN'S ASSOC | 3832 | P45728 | 2/28/2024 | 150.00 | 150.00 | 150.00 |
| 0051472 | 0000642 | FLORIDA PEST CONTROL | 3533 | P45464 | 2/28/2024 | 285.00 | | |
| | | | 3539 | P45493 | 2/28/2024 | 21.00 | | |
| | | | 3540 | P45419 | 2/28/2024 | 33.00 | | |
| | | | 3541 | P45503 | 2/28/2024 | 135.00 | | |
| | | | 3542 | P45560 | 2/28/2024 | 263.00 | | |
| | | | 3543 | P45561 | 2/28/2024 | 167.00 | | |
| | | | 3544 | P45563 | 2/28/2024 | 135.00 | | |
| | | | 3545 | P45564 | 2/28/2024 | 135.00 | | |
| | | | 3546 | P45565 | 2/28/2024 | 135.00 | | |
| | | | 3547 | P45566 | 2/28/2024 | 135.00 | | |
| | | | 3548 | P45567 | 2/28/2024 | 135.00 | | |
| | | | 3550 | P45479 | 2/28/2024 | 68.00 | | |
| | | | 3551 | P45480 | 2/28/2024 | 68.00 | | |
| | | | 3552 | P45562 | 2/28/2024 | 135.00 | | |
| | | | 3557 | P45524 | 2/28/2024 | 68.00 | | |
| | | | 3558 | P45525 | 2/28/2024 | 68.00 | | |
| | | | 3587 | P45463 | 2/28/2024 | 33.00 | | |
| | | | 3588 | P45463 | 2/28/2024 | 3.97- | | |
| | | | 3675 | P45603 | 2/28/2024 | 36.00 | | |
| | | | 3713 | P45755 | 2/28/2024 | 68.00 | | |

| CHECK NO | VENDOR NO | VENDOR NAME | VOUCHER NO | P.O. NO | DATE | VOUCHER AMOUNT | REMITTANCE AMOUNT | CHECK TOTAL |
|----------|-----------|---------------------------|------------|---------|-----------|----------------|-------------------|-------------|
| 0051472 | 0000642 | FLORIDA PEST CONTROL | 3715 | P45756 | 2/28/2024 | 68.00 | | |
| | | | 3716 | P45757 | 2/28/2024 | 68.00 | | |
| | | | 3717 | P45688 | 2/28/2024 | 63.00 | | |
| | | | 3718 | P45698 | 2/28/2024 | 53.00 | | |
| | | | 3721 | P45758 | 2/28/2024 | 68.00 | | |
| | | | 3727 | P45741 | 2/28/2024 | 21.00 | | |
| | | | 3738 | P45718 | 2/28/2024 | 34.72 | | |
| | | | 3755 | P45661 | 2/28/2024 | 35.00 | 2,529.75 | 2,529.75 |
| 0051473 | 0000613 | FLORIDA POWER & LIGHT | 3768 | P45772 | 2/28/2024 | 238.90 | | |
| | | | 3769 | P45773 | 2/28/2024 | 33.10 | 272.00 | 272.00 |
| 0051474 | 0003549 | FLORIDA RURAL WATER ASSOC | 3535 | P45483 | 2/28/2024 | 1,150.00 | 1,150.00 | 1,150.00 |
| 0051475 | 0004154 | FORT WHITE TRUE VALUE HAR | 3751 | P45727 | 2/28/2024 | 68.33 | | |
| | | | 3756 | P45664 | 2/28/2024 | 8.99 | 77.32 | 77.32 |
| 0051476 | 0004689 | FORTILINE, INC. | 3714 | P45711 | 2/28/2024 | 1,086.03 | 1,086.03 | 1,086.03 |
| 0051477 | 0004045 | FPL | 004208 | | 2/28/2024 | 15,942.63 | | |
| | | | 004209 | | 2/28/2024 | 4,584.41 | | |
| | | | 004210 | | 2/28/2024 | 2,367.39 | | |
| | | | 004211 | | 2/28/2024 | 137.97 | | |
| | | | 004212 | | 2/28/2024 | 642.33 | | |
| | | | 004213 | | 2/28/2024 | 713.62 | | |
| | | | 004214 | | 2/28/2024 | 10,846.11 | | |
| | | | 004215 | | 2/28/2024 | 2,330.75 | | |
| | | | 004216 | | 2/28/2024 | 616.58 | | |
| | | | 004217 | | 2/28/2024 | 551.09 | | |
| | | | 004218 | | 2/28/2024 | 394.32 | | |
| | | | 004219 | | 2/28/2024 | 4,340.37 | | |
| | | | 004220 | | 2/28/2024 | 6,629.93 | | |
| | | | 004221 | | 2/28/2024 | 1,321.86 | | |
| | | | 004222 | | 2/28/2024 | 1,307.82 | | |
| | | | 004223 | | 2/28/2024 | 213.60 | | |
| | | | 004224 | | 2/28/2024 | 1,084.70 | | |
| | | | 004225 | | 2/28/2024 | 126.47 | | |
| | | | 004226 | | 2/28/2024 | 1,088.36 | | |
| | | | 004227 | | 2/28/2024 | 656.30 | | |
| | | | 004228 | | 2/28/2024 | 355.70 | | |
| | | | 000108 | | 2/28/2024 | 268.08 | | |
| | | | 000109 | | 2/28/2024 | 262.22 | | |
| | | | 000110 | | 2/28/2024 | 105.29 | 56,887.90 | 56,887.90 |
| 0051478 | 0006028 | FUELED OUTDOORS | 3538 | P45016 | 2/28/2024 | 35.65 | | |
| | | | 3592 | P45487 | 2/28/2024 | 26.73 | | |
| | | | 3736 | P45622 | 2/28/2024 | 24.00 | | |
| | | | 3754 | P45641 | 2/28/2024 | 73.98 | 160.36 | 160.36 |
| 0051479 | 0000806 | G.W. HUNTER, INC. | PI3704 | 027124 | 2/28/2024 | 27,094.89 | 27,094.89 | 27,094.89 |
| 0051480 | 0001860 | GALE/CENGAGE LEARNING | 3676 | P45546 | 2/28/2024 | 127.96 | 127.96 | 127.96 |
| 0051481 | 0000759 | GATEWAY-FOREST LAWN FUNER | 001504 | | 2/28/2024 | 450.00 | | |
| | | | 001505 | | 2/28/2024 | 450.00 | | |
| | | | 001506 | | 2/28/2024 | 450.00 | | |
| | | | 001507 | | 2/28/2024 | 450.00 | 1,800.00 | 1,800.00 |
| 0051482 | 0005876 | GOLDSTAR PRODUCTS INC. | 3722 | P45669 | 2/28/2024 | 685.37 | 685.37 | 685.37 |
| 0051483 | 0004276 | GRADING AND BUSH HOG SERV | PI3522 | 027236 | 2/28/2024 | 3,248.50 | 3,248.50 | 3,248.50 |
| 0051484 | 0000724 | GRAINGER | 3569 | P45407 | 2/28/2024 | 126.60 | | |
| | | | 3590 | P45505 | 2/28/2024 | 126.09 | | |

PROGRAM GM344LR
COLUMBIA COUNTY
BANK 00

| CHECK NO | VENDOR NO | VENDOR NAME | VOUCHER NO | P.O. NO | DATE | VOUCHER AMOUNT | REMITTANCE AMOUNT | CHECK TOTAL |
|----------|-----------|---------------------------|------------|---------|-----------|----------------|-------------------|-------------|
| 0051484 | 0000724 | GRAINGER | 3591 | P45506 | 2/28/2024 | 162.38 | | |
| | | | 3739 | P45732 | 2/28/2024 | 121.02 | | |
| | | | 3748 | P45693 | 2/28/2024 | 47.96 | | |
| | | | 3749 | P45694 | 2/28/2024 | 224.84 | | |
| | | | 3750 | P45695 | 2/28/2024 | 405.48 | 1,214.37 | 1,214.37 |
| 0051485 | 0000794 | GREEN'S MARINE & SPORTING | 3565 | P45314 | 2/28/2024 | 103.14 | | |
| | | | 3760 | P45730 | 2/28/2024 | 89.94 | | |
| | | | 3761 | P45748 | 2/28/2024 | 847.98 | | |
| | | | 3762 | P45748 | 2/28/2024 | 607.98 | | |
| | | | 3763 | P45748 | 2/28/2024 | 343.99 | | |
| | | | 3764 | P45748 | 2/28/2024 | 239.99 | 2,233.02 | 2,233.02 |
| 0051486 | 0002155 | GUARDIAN COMMUNITY RESOUR | 001477 | | 2/28/2024 | 7,600.00 | | |
| | | | 001478 | | 2/28/2024 | 4,325.00 | | |
| | | | 001479 | | 2/28/2024 | 5,794.44 | | |
| | | | 001479 | | 2/28/2024 | 2,222.22 | 19,941.66 | 19,941.66 |
| 0051487 | 0004804 | HAWKINS, INC. | 3758 | P45713 | 2/28/2024 | 429.00 | | |
| | | | 3759 | P45714 | 2/28/2024 | 157.30 | 586.30 | 586.30 |
| 0051488 | 0004356 | HEATHER BLAIR | 3766 | P45737 | 2/28/2024 | 43.61 | 43.61 | 43.61 |
| 0051489 | 0005549 | HEROES UNIFORMS & SCRUBS | 3586 | P45555 | 2/28/2024 | 180.00 | 180.00 | 180.00 |
| 0051490 | 0000818 | HILL MANUFACTURING CO., I | 3731 | P45457 | 2/28/2024 | 613.00 | | |
| | | | 3752 | P45606 | 2/28/2024 | 542.00 | 1,155.00 | 1,155.00 |
| 0051491 | 0006104 | HOFFMAN COMMERCIAL LAUNDR | 3757 | P45687 | 2/28/2024 | 726.02 | 726.02 | 726.02 |
| 0051492 | 0002133 | HOME DEPOT CREDIT SERVICE | 3723 | P45720 | 2/28/2024 | 159.00 | 159.00 | 159.00 |
| 0051493 | 0002718 | HOME DEPOT PRO | 3534 | P44815 | 2/28/2024 | 194.82 | 194.82 | 194.82 |
| 0051494 | 0003685 | HUB CITY INDUSTRIAL SUPPL | 3564 | P45608 | 2/28/2024 | 84.82 | 84.82 | 84.82 |
| 0051495 | 0005367 | IMMAC POWER SOLUTIONS INC | 3511 | 027075 | 2/28/2024 | 500.00 | | |
| | | | 001514 | 027075 | 2/28/2024 | 500.00 | 1,000.00 | 1,000.00 |
| 0051496 | 0000911 | INTERSTATE SUPPLY | 3555 | P45551 | 2/28/2024 | 145.46 | | |
| | | | 3556 | P45552 | 2/28/2024 | 172.23 | | |
| | | | 3563 | P45501 | 2/28/2024 | 1,234.42 | | |
| | | | 3575 | P45500 | 2/28/2024 | 599.03 | | |
| | | | 3580 | P45514 | 2/28/2024 | 35.80 | | |
| | | | 3585 | P45522 | 2/28/2024 | 41.81 | | |
| | | | 3589 | P45502 | 2/28/2024 | 18.60 | | |
| | | | 3712 | P45183 | 2/28/2024 | 143.33 | | |
| | | | 3719 | P45709 | 2/28/2024 | 51.33 | | |
| | | | 3733 | P45719 | 2/28/2024 | 204.28 | | |
| | | | 3734 | P45731 | 2/28/2024 | 19.77 | | |
| | | | 3745 | P45678 | 2/28/2024 | 297.00 | | |
| | | | 3746 | P45679 | 2/28/2024 | 210.63 | 3,173.69 | 3,173.69 |
| 0051497 | 0005347 | JAY CAPASSO | 3741 | P45626 | 2/28/2024 | 183.20 | | |
| | | | 3742 | P45626 | 2/28/2024 | 308.47 | | |
| | | | 3743 | P45626 | 2/28/2024 | 138.26 | | |
| | | | 3744 | P45626 | 2/28/2024 | 186.23 | 816.16 | 816.16 |
| 0051498 | 0001025 | JSC SYSTEMS, INC. | 3576 | P45509 | 2/28/2024 | 300.00 | | |
| | | | 3577 | P45510 | 2/28/2024 | 300.00 | 600.00 | 600.00 |
| 0051499 | 0005039 | JULIA FULTON | 3740 | P45625 | 2/28/2024 | 86.90 | 86.90 | 86.90 |
| 0051500 | 0006274 | JWC ENVIRONMENTAL INC. | 3537 | P45512 | 2/28/2024 | 969.92 | 969.92 | 969.92 |
| 0051501 | 0006238 | KC CREATIONS CUSTOM EMBRO | 3818 | P45631 | 2/28/2024 | 756.28 | 756.28 | 756.28 |
| 0051502 | 0006280 | KEN & AMY SNIDER | 001549 | | 2/28/2024 | 26.87 | | |
| | | | 001550 | | 2/28/2024 | 80.00 | 106.87 | 106.87 |
| 0051503 | 0001968 | KIMI ROBERTS | 001457 | | 2/28/2024 | 8.28 | | |

PROGRAM GM344LR
COLUMBIA COUNTY
BANK 00

| CHECK NO | VENDOR NO | VENDOR NAME | VOUCHER NO | P.O. NO | DATE | VOUCHER AMOUNT | REMITTANCE AMOUNT | CHECK TOTAL |
|----------|-----------|---------------------------|------------|---------|-----------|----------------|-------------------|-------------|
| 0051503 | 0001968 | KIMI ROBERTS | 001508 | | 2/28/2024 | 8.28 | | |
| | | | 001553 | | 2/28/2024 | 8.28 | 24.84 | 24.84 |
| 0051504 | 0006126 | KNIGHT TECHNOLOGY GROUP | 3593 | P45526 | 2/28/2024 | 424.87 | | |
| | | | 3594 | P45529 | 2/28/2024 | 917.67 | | |
| | | | 3687 | P45536 | 2/28/2024 | 448.00 | | |
| | | | 3834 | P45747 | 2/28/2024 | 159.87 | 1,950.41 | 1,950.41 |
| 0051505 | 0001231 | LAKE CITY ADVERTISER | 3673 | P45471 | 2/28/2024 | 500.00 | 500.00 | 500.00 |
| 0051506 | 0001212 | LAKE CITY AUTO PARTS | 3603 | P45568 | 2/28/2024 | 19.08 | | |
| | | | 3622 | P45275 | 2/28/2024 | 8.50 | | |
| | | | 3627 | P45339 | 2/28/2024 | 105.60 | | |
| | | | 3646 | P45569 | 2/28/2024 | 58.67 | 191.85 | 191.85 |
| 0051507 | 0001230 | LAKE CITY INDUSTRIES | 3657 | P45507 | 2/28/2024 | 20.68 | | |
| | | | 3813 | P45696 | 2/28/2024 | 36.48 | | |
| | | | 3822 | P45697 | 2/28/2024 | 11.25 | 68.41 | 68.41 |
| 0051508 | 0001241 | LAKE CITY REPORTER | 3831 | P45670 | 2/28/2024 | 83.00 | 83.00 | 83.00 |
| 0051509 | 0001215 | LAKE CITY TITLE | 001554 | | 2/28/2024 | 3,698.65 | | |
| | | | 001555 | | 2/28/2024 | 3,544.25 | | |
| | | | 001556 | | 2/28/2024 | 3,544.25 | | |
| | | | 001557 | | 2/28/2024 | 6,665.95 | 17,453.10 | 17,453.10 |
| 0051510 | 0004710 | LAWSON PRODUCTS, INC. | 3602 | P44997 | 2/28/2024 | 350.86 | | |
| | | | 3607 | P45202 | 2/28/2024 | 570.00 | | |
| | | | 3784 | P45389 | 2/28/2024 | 380.10 | 1,300.96 | 1,300.96 |
| 0051511 | 0001242 | LEONARD FRAME SHOP | 3642 | P45469 | 2/28/2024 | 80.00 | 80.00 | 80.00 |
| 0051512 | 0003020 | LEVY JONES | 3640 | P45558 | 2/28/2024 | 130.90 | 130.90 | 130.90 |
| 0051513 | 0003774 | LIQUID ENVIRONMENTAL SOLU | PI3872 | 027261 | 2/28/2024 | 982.44 | | |
| | | | PI3873 | 027261 | 2/28/2024 | 936.05 | | |
| | | | PI3874 | 027261 | 2/28/2024 | 985.48 | | |
| | | | PI3875 | 027261 | 2/28/2024 | 972.12 | | |
| | | | PI3876 | 027261 | 2/28/2024 | 982.67 | | |
| | | | PI3877 | 027261 | 2/28/2024 | 982.67 | | |
| | | | PI3878 | 027261 | 2/28/2024 | 985.72 | | |
| | | | PI3879 | 027261 | 2/28/2024 | 981.91 | | |
| | | | PI3880 | 027261 | 2/28/2024 | 980.37 | | |
| | | | PI3881 | 027261 | 2/28/2024 | 973.66 | | |
| | | | PI3882 | 027261 | 2/28/2024 | 982.48 | | |
| | | | PI3883 | 027261 | 2/28/2024 | 979.56 | | |
| | | | PI3884 | 027261 | 2/28/2024 | 982.87 | | |
| | | | PI3885 | 027261 | 2/28/2024 | 983.83 | | |
| | | | PI3886 | 027261 | 2/28/2024 | 987.28 | | |
| | | | PI3887 | 027261 | 2/28/2024 | 1,007.56 | | |
| | | | PI3888 | 027261 | 2/28/2024 | 1,003.01 | | |
| | | | PI3889 | 027261 | 2/28/2024 | 1,008.12 | | |
| | | | PI3890 | 027261 | 2/28/2024 | 982.04 | | |
| | | | PI3891 | 027261 | 2/28/2024 | 983.06 | | |
| | | | PI3892 | 027261 | 2/28/2024 | 994.36 | | |
| | | | PI3893 | 027261 | 2/28/2024 | 1,008.00 | | |
| | | | PI3894 | 027261 | 2/28/2024 | 992.65 | | |
| | | | PI3895 | 027261 | 2/28/2024 | 979.16 | | |
| | | | PI3896 | 027261 | 2/28/2024 | 959.64 | | |
| | | | PI3897 | 027261 | 2/28/2024 | 978.76 | | |
| | | | PI3898 | 027261 | 2/28/2024 | 969.24 | | |
| | | | PI3899 | 027261 | 2/28/2024 | 981.64 | | |

| CHECK NO | VENDOR NO | VENDOR NAME | VOUCHER NO | P.O. NO | DATE | VOUCHER AMOUNT | REMITTANCE AMOUNT | CHECK TOTAL |
|----------|-----------|---------------------------|------------|---------|-----------|----------------|-------------------|-------------|
| 0051513 | 0003774 | LIQUID ENVIRONMENTAL | SOLUPI3900 | 027261 | 2/28/2024 | 1,000.84 | 28,527.19 | 28,527.19 |
| 0051514 | 0001262 | LOWE'S PROX | 3647 | P45490 | 2/28/2024 | 372.06 | | |
| | | | 3774 | P45624 | 2/28/2024 | 362.80 | | |
| | | | 3780 | P45707 | 2/28/2024 | 171.13 | | |
| | | | 3790 | P45699 | 2/28/2024 | 99.74 | | |
| | | | 3806 | P45744 | 2/28/2024 | 132.10 | | |
| | | | 3812 | P45677 | 2/28/2024 | 51.92 | | |
| | | | 3817 | P45629 | 2/28/2024 | 47.30 | | |
| | | | 3833 | P45745 | 2/28/2024 | 9.22 | 1,227.83 | 1,227.83 |
| 0051515 | 0001216 | LUBE SPECIALISTS | 3609 | P45167 | 2/28/2024 | 113.05 | | |
| | | | 3610 | P45177 | 2/28/2024 | 25.83 | | |
| | | | 3619 | P45256 | 2/28/2024 | 599.00 | | |
| | | | 3621 | P45262 | 2/28/2024 | 507.06 | | |
| | | | 3625 | P45267 | 2/28/2024 | 145.02 | | |
| | | | 3786 | P45416 | 2/28/2024 | 316.78 | | |
| | | | 3787 | P45454 | 2/28/2024 | 69.93 | | |
| | | | 3788 | P45473 | 2/28/2024 | 97.14 | | |
| | | | 3789 | P45474 | 2/28/2024 | 83.22 | | |
| | | | 3791 | P45498 | 2/28/2024 | 93.84 | | |
| | | | 3800 | P45738 | 2/28/2024 | 39.70 | | |
| | | | 3830 | P45254 | 2/28/2024 | 163.32 | 2,253.89 | 2,253.89 |
| 0051516 | 0000118 | MATHESON TRI-GAS INC. | 3601 | P43424 | 2/28/2024 | 187.69 | | |
| | | | 3643 | P45523 | 2/28/2024 | 146.40 | | |
| | | | 3835 | P45786 | 2/28/2024 | 120.95 | 455.04 | 455.04 |
| 0051517 | 0001319 | MCCRIMON'S OFFICE SUPPLY | 001479 | | 2/28/2024 | 296.82 | | |
| | | | 001479 | | 2/28/2024 | 47.23 | | |
| | | | 001479 | | 2/28/2024 | 43.70 | | |
| | | | 001479 | | 2/28/2024 | 79.26 | | |
| | | | 001536 | | 2/28/2024 | 68.47 | | |
| | | | 001537 | | 2/28/2024 | 12.93 | | |
| | | | 3836 | P45774 | 2/28/2024 | 111.85 | | |
| | | | 3837 | P45775 | 2/28/2024 | 106.95 | 767.21 | 767.21 |
| 0051518 | 0001351 | METAL MASTERS OF FLORIDA | 3779 | P45252 | 2/28/2024 | 729.00 | | |
| | | | 3783 | P45387 | 2/28/2024 | 729.00 | | |
| | | | 3785 | P45388 | 2/28/2024 | 729.00 | | |
| | | | 3808 | P45591 | 2/28/2024 | 707.00 | 2,894.00 | 2,894.00 |
| 0051519 | 0001329 | MIDWEST TAPE EXCHANGE | PI3515 | 027083 | 2/28/2024 | 107.91 | | |
| | | | PI3516 | 027084 | 2/28/2024 | 53.32 | 161.23 | 161.23 |
| 0051520 | 0001347 | MINI-STORAGE/RECORD STORA | 001509 | | 2/28/2024 | 2,293.50 | | |
| | | | 001543 | | 2/28/2024 | 2,152.50 | | |
| | | | 001544 | | 2/28/2024 | 2,478.00 | | |
| | | | 001545 | | 2/28/2024 | 2,023.50 | | |
| | | | 001546 | | 2/28/2024 | 2,169.00 | | |
| | | | 001547 | | 2/28/2024 | 2,068.50 | 13,185.00 | 13,185.00 |
| 0051521 | 0003837 | MOTOROLA SOLUTIONS, INC. | 3807 | P45759 | 2/28/2024 | 113.52 | 113.52 | 113.52 |
| 0051522 | 0006107 | MOYLE LAW FIRM, P.A. | 001479 | | 2/28/2024 | 3,382.05 | 3,382.05 | 3,382.05 |
| 0051523 | 0003909 | MURRAY TIRE, LLC | 3613 | P45255 | 2/28/2024 | 75.00 | | |
| | | | 3630 | P45385 | 2/28/2024 | 30.00 | 105.00 | 105.00 |
| 0051524 | 0000182 | NAPA AUTO PARTS FORT WHIT | 3810 | P45598 | 2/28/2024 | 224.99 | 224.99 | 224.99 |
| 0051525 | 0001434 | NE-RO TIRE & BRAKE SERVIC | 3628 | P45343 | 2/28/2024 | 535.54 | | |
| | | | 3666 | P45539 | 2/28/2024 | 578.56 | | |
| | | | 3667 | P45540 | 2/28/2024 | 49.95 | | |

PROGRAM GM344LR
COLUMBIA COUNTY
BANK 00

| CHECK NO | VENDOR NO | VENDOR NAME | VOUCHER NO | P.O. NO | DATE | VOUCHER AMOUNT | REMITTANCE AMOUNT | CHECK TOTAL |
|----------|-----------|-----------------------------|------------|---------|-----------|----------------|-------------------|-------------|
| 0051525 | 0001434 | NE-RO TIRE & BRAKE SERVICE | 3709 | 027293 | 2/28/2024 | 7,261.25 | | |
| | | | 3782 | P45353 | 2/28/2024 | 2,396.85 | 10,822.15 | 10,822.15 |
| 0051526 | 0001429 | NEXTRAN TRUCK CENTER | 3811 | P45615 | 2/28/2024 | 187.63 | | |
| | | | 3814 | P45616 | 2/28/2024 | 157.93 | | |
| | | | 3815 | P45617 | 2/28/2024 | 535.56 | 881.12 | 881.12 |
| 0051527 | 0001414 | NORFOLK SOUTHERN RAILWAY | 3599 | P45579 | 2/28/2024 | 464.50 | 464.50 | 464.50 |
| 0051528 | 0001403 | NORTH CENTRAL FLORIDA REG | 3528 | 027286 | 2/28/2024 | 8,750.00 | 8,750.00 | 8,750.00 |
| 0051529 | 0001018 | NORTH FLORIDA GLASS | 3604 | P45578 | 2/28/2024 | 1,250.00 | | |
| | | | 3680 | P45638 | 2/28/2024 | 400.00 | 1,650.00 | 1,650.00 |
| 0051530 | 0006029 | ODP BUSINESS SOLUTIONS, L | 3529 | P45334 | 2/28/2024 | 38.69 | | |
| | | | 3608 | P45482 | 2/28/2024 | 77.97 | | |
| | | | 3615 | P45456 | 2/28/2024 | 124.56 | | |
| | | | 3634 | P45459 | 2/28/2024 | 138.50 | | |
| | | | 3635 | P45459 | 2/28/2024 | 15.58 | | |
| | | | 3648 | P45491 | 2/28/2024 | 12.99 | | |
| | | | 3649 | P45491 | 2/28/2024 | 8.19 | | |
| | | | 3650 | P45491 | 2/28/2024 | 5.38 | | |
| | | | 3651 | P45491 | 2/28/2024 | 5.38 | | |
| | | | 3652 | P45491 | 2/28/2024 | 8.07 | | |
| | | | 3653 | P45491 | 2/28/2024 | 5.38 | | |
| | | | 3654 | P45491 | 2/28/2024 | 5.38 | | |
| | | | 3655 | P45491 | 2/28/2024 | 5.38 | | |
| | | | 3656 | P45491 | 2/28/2024 | 51.16 | | |
| | | | 3792 | P45610 | 2/28/2024 | 88.80 | | |
| | | | 3825 | P45723 | 2/28/2024 | 96.99 | | |
| | | | 3826 | P45723 | 2/28/2024 | 116.99 | | |
| | | | 3827 | P45723 | 2/28/2024 | 116.99 | | |
| | | | 3828 | P45723 | 2/28/2024 | 116.99 | | |
| | | | 3829 | P45723 | 2/28/2024 | 7.70 | | |
| | | | 3840 | P45356 | 2/28/2024 | 10.52 | 1,057.59 | 1,057.59 |
| 0051531 | 0004881 | OPTIMUM WATER SOLUTIONS, | 3606 | P45583 | 2/28/2024 | 48.00 | 48.00 | 48.00 |
| 0051532 | 0003267 | OVERHEAD DOOR COMPANY OF | 3624 | P45553 | 2/28/2024 | 315.00 | 315.00 | 315.00 |
| 0051533 | 0005864 | PARADISE ADVERTISING & MAPI | 3705 | 027126 | 2/28/2024 | 262.50 | 262.50 | 262.50 |
| 0051534 | 0005911 | PARKING BOXX CORP. | 3776 | P45724 | 2/28/2024 | 200.00 | 200.00 | 200.00 |
| 0051535 | 0001041 | PETE OLIN AUTO PARTS, INC | 3823 | P45590 | 2/28/2024 | 150.00 | | |
| | | | 3824 | P45662 | 2/28/2024 | 35.71 | 185.71 | 185.71 |
| 0051536 | 0001710 | PETTY CASH | 3658 | P45531 | 2/28/2024 | 2.58 | | |
| | | | 3659 | P45531 | 2/28/2024 | 157.94 | 160.52 | 160.52 |
| 0051537 | 0005930 | POWERHOUSE PEST CONTROL I | 3645 | P45557 | 2/28/2024 | 35.00 | | |
| | | | 3819 | P45632 | 2/28/2024 | 45.00 | | |
| | | | 3820 | P45633 | 2/28/2024 | 50.00 | | |
| | | | 3821 | P45634 | 2/28/2024 | 35.00 | 165.00 | 165.00 |
| 0051538 | 0001973 | PREFERRED GOVERNMENTAL IN | 002501 | | 2/28/2024 | 298.25 | | |
| | | | 002503 | | 2/28/2024 | 33.44 | | |
| | | | 002504 | | 2/28/2024 | 365.49 | | |
| | | | 002505 | | 2/28/2024 | 4,950.51 | | |
| | | | 002506 | | 2/28/2024 | 19.92 | | |
| | | | 002507 | | 2/28/2024 | 349.04 | | |
| | | | 002508 | | 2/28/2024 | 717.81 | | |
| | | | 002509 | | 2/28/2024 | 39.29 | | |
| | | | 002511 | | 2/28/2024 | 102.88 | | |
| | | | 002512 | | 2/28/2024 | 6,717.26 | | |

| CHECK NO | VENDOR NO | VENDOR NAME | VOUCHER NO | P.O. NO | DATE | VOUCHER AMOUNT | REMITTANCE AMOUNT | CHECK TOTAL |
|----------|-----------|----------------------------|------------|---------|-----------|----------------|-------------------|-------------|
| 0051538 | 0001973 | PREFERRED GOVERNMENTAL | IN002513 | | 2/28/2024 | 10.42 | | |
| | | | 002514 | | 2/28/2024 | 472.02 | | |
| | | | 002515 | | 2/28/2024 | 21.38 | | |
| | | | 002516 | | 2/28/2024 | 13,095.36 | | |
| | | | 002517 | | 2/28/2024 | 6,864.55 | | |
| | | | 002518 | | 2/28/2024 | 6,044.77 | | |
| | | | 002519 | | 2/28/2024 | 4,917.06 | | |
| | | | 002520 | | 2/28/2024 | 5,698.11 | | |
| | | | 002521 | | 2/28/2024 | 653.12 | | |
| | | | 002522 | | 2/28/2024 | 5,207.44 | | |
| | | | 002523 | | 2/28/2024 | 12,170.68 | | |
| | | | 002524 | | 2/28/2024 | 7,868.00 | | |
| | | | 002525 | | 2/28/2024 | 35,194.64 | | |
| | | | 002526 | | 2/28/2024 | 146.74 | | |
| | | | 002527 | | 2/28/2024 | 2,385.71 | | |
| | | | 002529 | | 2/28/2024 | 71.27 | | |
| | | | 002530 | | 2/28/2024 | 33.62 | | |
| | | | 002531 | | 2/28/2024 | 9.32 | | |
| | | | 002532 | | 2/28/2024 | 36.18 | | |
| | | | 002533 | | 2/28/2024 | 373.16 | | |
| | | | 002534 | | 2/28/2024 | 49.71 | | |
| | | | 002535 | | 2/28/2024 | 20.65 | | |
| | | | 002536 | | 2/28/2024 | 67.98 | | |
| | | | 002537 | | 2/28/2024 | 8,130.78 | | |
| | | | 002538 | | 2/28/2024 | 526.30 | | |
| | | | 000054 | | 2/28/2024 | 93.38 | | |
| | | | 000055 | | 2/28/2024 | 526.30 | | |
| | | | 000055 | | 2/28/2024 | 526.31 | | |
| | | | 000056 | | 2/28/2024 | 565.04 | | |
| | | | 000280 | | 2/28/2024 | 274.11 | 125,648.00 | 125,648.00 |
| 0051539 | 0004063 | PREMIER PAPER & JANITORIA | 3641 | P45455 | 2/28/2024 | 450.58 | | |
| | | | 3644 | P45556 | 2/28/2024 | 214.76 | | |
| | | | 3809 | P45596 | 2/28/2024 | 673.55 | | |
| | | | 3816 | P45623 | 2/28/2024 | 95.88 | 1,434.77 | 1,434.77 |
| 0051540 | 0001793 | PREMIER WATER & ENERGY TE | 3775 | P45689 | 2/28/2024 | 568.37 | 568.37 | 568.37 |
| 0051541 | 0004345 | PRITCHETT TRUCKING, INC. | PI2891 | 027076 | 2/28/2024 | 1,645.00 | | |
| | | | PI3698 | 027076 | 2/28/2024 | 1,645.00 | 3,290.00 | 3,290.00 |
| 0051542 | 0006276 | PROFESSIONAL DEVELOPMENT | 3696 | P45614 | 2/28/2024 | 750.00 | 750.00 | 750.00 |
| 0051543 | 0001763 | PUBLIC DEFENDER | 001539 | | 2/28/2024 | 810.17 | 810.17 | 810.17 |
| 0051544 | 0001175 | PUBLIC DEFENDER I.T. | 001538 | | 2/28/2024 | 2,770.83 | 2,770.83 | 2,770.83 |
| 0051545 | 0004621 | QUADIENNT LEASING USA, INC | PI3871 | 027203 | 2/28/2024 | 426.27 | 426.27 | 426.27 |
| 0051546 | 0001901 | RAPID PRESS | 3530 | P45461 | 2/28/2024 | 225.00 | | |
| | | | 3614 | P45441 | 2/28/2024 | 75.00 | 300.00 | 300.00 |
| 0051547 | 0001183 | RELIABLE SHREDDING SERVIC | 3631 | P45478 | 2/28/2024 | 80.50 | 80.50 | 80.50 |
| 0051548 | 0001907 | RING POWER CORP. | PI3525 | 027274 | 2/28/2024 | 5,740.80 | | |
| | | | PI3526 | 027275 | 2/28/2024 | 3,127.27 | | |
| | | | 3597 | P45582 | 2/28/2024 | 586.82 | | |
| | | | 3605 | P45141 | 2/28/2024 | 67.92 | | |
| | | | 3626 | P45281 | 2/28/2024 | 501.27 | | |
| | | | 3633 | P45352 | 2/28/2024 | 590.38 | | |
| | | | PI3671 | 027176 | 2/28/2024 | 13,195.96 | | |
| | | | 3690 | P45648 | 2/28/2024 | 825.00 | | |

PROGRAM GM344LR
COLUMBIA COUNTY
BANK 00

| CHECK NO | VENDOR NO | VENDOR NAME | VOUCHER NO | P.O. NO | DATE | VOUCHER AMOUNT | REMITTANCE AMOUNT | CHECK TOTAL |
|----------|-----------|-----------------------------|------------|---------|-----------|----------------|-------------------|-------------|
| 0051548 | 0001907 | RING POWER CORP. | 3691 | P45651 | 2/28/2024 | 16.00 | | |
| | | | 3694 | P45656 | 2/28/2024 | 948.68 | | |
| | | | 3695 | P45657 | 2/28/2024 | 762.90 | | |
| | | | 3777 | P44917 | 2/28/2024 | 1,306.58 | | |
| | | | 3778 | P45156 | 2/28/2024 | 2,158.05 | | |
| | | | 3781 | P45342 | 2/28/2024 | 1,245.23 | | |
| | | | 3793 | P45643 | 2/28/2024 | 2,304.41 | | |
| | | | 3794 | P45644 | 2/28/2024 | 1,823.25 | | |
| | | | 3795 | P45645 | 2/28/2024 | 1,987.50 | | |
| | | | 3796 | P45646 | 2/28/2024 | 1,853.78 | | |
| | | | 3797 | P45647 | 2/28/2024 | 2,079.14 | | |
| | | | 3798 | P45649 | 2/28/2024 | 1,859.00 | | |
| | | | 3799 | P45650 | 2/28/2024 | 2,145.00 | | |
| | | | 3801 | P45652 | 2/28/2024 | 1,582.04 | | |
| | | | 3802 | P45653 | 2/28/2024 | 2,000.00 | | |
| | | | 3803 | P45654 | 2/28/2024 | 2,304.37 | | |
| | | | 3804 | P45655 | 2/28/2024 | 2,312.26 | | |
| | | | 3805 | P45658 | 2/28/2024 | 2,335.71 | 55,659.32 | 55,659.32 |
| 0051549 | 0000005 | ROBBIN ODOWSKI | 001557 | | 2/28/2024 | 200.00 | 200.00 | 200.00 |
| 0051550 | 0006261 | NORTH CENTRAL EMS CORPORA | 3632 | P45554 | 2/28/2024 | 179.96 | | |
| | | | 3846 | P45621 | 2/28/2024 | 381.89 | 561.85 | 561.85 |
| 0051551 | 0001189 | SHANE OVERSTREET | 3682 | P45452 | 2/28/2024 | 203.00 | 203.00 | 203.00 |
| 0051552 | 0004796 | SHARP ELECTRONICS CORPORA | PI3519 | 027169 | 2/28/2024 | 159.85 | | |
| | | | PI3520 | 027175 | 2/28/2024 | 117.28 | | |
| | | | PI3527 | 027288 | 2/28/2024 | 83.12 | | |
| | | | 3612 | P45584 | 2/28/2024 | 75.61 | | |
| | | | PI3668 | 027086 | 2/28/2024 | 53.03 | | |
| | | | PI3669 | 027086 | 2/28/2024 | 53.03 | | |
| | | | PI3670 | 027086 | 2/28/2024 | 34.77 | | |
| | | | 3674 | P45600 | 2/28/2024 | 95.42 | | |
| | | | 3692 | P45570 | 2/28/2024 | 135.53 | 807.64 | 807.64 |
| 0051553 | 0001355 | SHAYNE MORGAN | 3683 | P45453 | 2/28/2024 | 199.00 | 199.00 | 199.00 |
| 0051554 | 0009952 | SONIA GARDEN | 001479 | | 2/28/2024 | 330.00 | 330.00 | 330.00 |
| 0051555 | 0003056 | SOUTHEASTERN TURFGRASS SUPI | 3524 | 027256 | 2/28/2024 | 26,122.25 | 26,122.25 | 26,122.25 |
| 0051556 | 0000287 | SOUTHERN SPECIALIZED LLC | PI3518 | 027148 | 2/28/2024 | 3,363.19 | 3,363.19 | 3,363.19 |
| 0051557 | 0002022 | STATE ATTORNEY'S OFFICE-F | 001577 | | 2/28/2024 | 2,711.70 | | |
| | | | 001578 | | 2/28/2024 | 9,598.75 | 12,310.45 | 12,310.45 |
| 0051558 | 0006275 | SUAREZ, JOSE | 001455 | | 2/28/2024 | 33.13- | | |
| | | | 001456 | | 2/28/2024 | 60.00 | 26.87 | 26.87 |
| 0051559 | 0000814 | SUPERION, LLC | 001510 | | 2/28/2024 | 2,021.25 | 2,021.25 | 2,021.25 |
| 0051560 | 0008512 | SUWANNEE RIVER ECONOMIC C | 001557 | | 2/28/2024 | 9,800.00 | 9,800.00 | 9,800.00 |
| 0051561 | 0002018 | SUWANNEE VALLEY 4 C'S | 001511 | | 2/28/2024 | 2,500.00 | 2,500.00 | 2,500.00 |
| 0051562 | 0005203 | THE LAW OFFICE OF JOEL F. | 001458 | | 2/28/2024 | 40.98 | 40.98 | 40.98 |
| 0051563 | 0002176 | THOMAS HARDWARE FARM & LU | 3842 | P45715 | 2/28/2024 | 1,431.21 | | |
| | | | 3857 | P45753 | 2/28/2024 | 431.40 | | |
| | | | 3858 | P45753 | 2/28/2024 | 63.92 | | |
| | | | 3859 | P45753 | 2/28/2024 | 183.80 | | |
| | | | 3860 | P45753 | 2/28/2024 | 239.90 | | |
| | | | 3861 | P45753 | 2/28/2024 | 4.78 | | |
| | | | 3862 | P45753 | 2/28/2024 | 19.98 | | |
| | | | 3863 | P45753 | 2/28/2024 | 21.56 | 2,396.55 | 2,396.55 |
| 0051564 | 0001458 | TOM NEHL TRUCK COMPANY | 3618 | P45253 | 2/28/2024 | 332.21 | | |

PROGRAM GM344LR
COLUMBIA COUNTY
BANK 00

| CHECK NO | VENDOR NO | VENDOR NAME | VOUCHER NO | P.O. NO | DATE | VOUCHER AMOUNT | REMITTANCE AMOUNT | CHECK TOTAL |
|----------|-----------|---------------------------|------------|---------|-----------|----------------|-------------------|-------------|
| 0051564 | 0001458 | TOM NEHL TRUCK COMPANY | 3864 | P45665 | 2/28/2024 | 442.96 | 775.17 | 775.17 |
| 0051565 | 0004627 | TRANE US, INC. | 3617 | P45508 | 2/28/2024 | 84.60 | 84.60 | 84.60 |
| 0051566 | 0005417 | TRUE LEAF MARKET | 3681 | P45243 | 2/28/2024 | 75.99 | 75.99 | 75.99 |
| 0051567 | 0004180 | ULINE | 3623 | P45467 | 2/28/2024 | 91.14 | 91.14 | 91.14 |
| 0051568 | 0003989 | UNIFIRST CORPORATION | 3629 | P45408 | 2/28/2024 | 15.74 | | |
| | | | 3636 | P45494 | 2/28/2024 | 903.66 | | |
| | | | 3638 | P45520 | 2/28/2024 | 174.21 | | |
| | | | 3639 | P45521 | 2/28/2024 | 72.37 | | |
| | | | 3665 | P45532 | 2/28/2024 | 101.73 | | |
| | | | 3688 | P45537 | 2/28/2024 | 29.68 | | |
| | | | 3689 | P45604 | 2/28/2024 | 15.74 | | |
| | | | 3697 | P45639 | 2/28/2024 | 76.30 | | |
| | | | 3841 | P45708 | 2/28/2024 | 70.98 | | |
| | | | 3849 | P45700 | 2/28/2024 | 174.21 | | |
| | | | 3850 | P45701 | 2/28/2024 | 72.37 | | |
| | | | 3851 | P45706 | 2/28/2024 | 733.56 | | |
| | | | 3852 | P45746 | 2/28/2024 | 70.98 | | |
| | | | 3866 | P45721 | 2/28/2024 | 29.68 | | |
| | | | 3867 | P45736 | 2/28/2024 | 241.64 | 2,782.85 | 2,782.85 |
| 0051569 | 0004909 | UNITED REFRIGERATION, INC | 3637 | P45519 | 2/28/2024 | 121.44 | | |
| | | | 3661 | P45571 | 2/28/2024 | 71.64 | | |
| | | | 3662 | P45572 | 2/28/2024 | 302.66 | | |
| | | | 3663 | P45573 | 2/28/2024 | 62.76 | | |
| | | | 3677 | P45605 | 2/28/2024 | 64.80 | | |
| | | | 3678 | P45605 | 2/28/2024 | 68.40 | | |
| | | | 3679 | P45605 | 2/28/2024 | 34.20 | | |
| | | | 3845 | P45705 | 2/28/2024 | 137.40 | | |
| | | | 3847 | P45683 | 2/28/2024 | 582.43 | | |
| | | | 3848 | P45686 | 2/28/2024 | 7.11 | | |
| | | | 3856 | P45784 | 2/28/2024 | 62.76 | | |
| | | | 3868 | P45785 | 2/28/2024 | 26.70 | | |
| | | | PI3901 | 027270 | 2/28/2024 | 4,402.98 | 5,945.28 | 5,945.28 |
| 0051570 | 0004922 | UNIVERSAL ENVIRONMENTAL S | 3685 | P45636 | 2/28/2024 | 284.45 | | |
| | | | 3853 | P45783 | 2/28/2024 | 25.00 | 309.45 | 309.45 |
| 0051571 | 0003817 | USABLUEBOOK | 3839 | P45710 | 2/28/2024 | 60.90 | 60.90 | 60.90 |
| 0051572 | 0000223 | VANN CARPET ONE | 3600 | P45544 | 2/28/2024 | 67.05 | | |
| | | | 3616 | P45504 | 2/28/2024 | 122.98 | 190.03 | 190.03 |
| 0051573 | 0002673 | VERIZON WIRELESS | 3855 | P45628 | 2/28/2024 | 36.07 | 36.07 | 36.07 |
| 0051574 | 0006223 | VOICE FOR CHILDREN (OP) | 3870 | P45779 | 2/28/2024 | 1,658.23 | 1,658.23 | 1,658.23 |
| 0051575 | 0004458 | WASTE UNIVERSITY | 3686 | P45528 | 2/28/2024 | 1,614.00 | 1,614.00 | 1,614.00 |
| 0051576 | 0006266 | WEAVER CLEAN, LLC | 3869 | P45778 | 2/28/2024 | 400.00 | 400.00 | 400.00 |
| 0051577 | 0002462 | WHITEHEAD HARDWARE COMPAN | 3620 | P45257 | 2/28/2024 | 447.12 | 447.12 | 447.12 |
| 0051578 | 0000129 | WINDSTREAM | 3611 | P45417 | 2/28/2024 | 131.20 | 131.20 | 131.20 |
| 0051579 | 0005190 | WINSUPPLY | 3598 | P45513 | 2/28/2024 | 22.90 | | |
| | | | 3660 | P45559 | 2/28/2024 | 6.20 | | |
| | | | 3664 | P45577 | 2/28/2024 | 30.99 | | |
| | | | 3843 | P45726 | 2/28/2024 | 21.05 | | |
| | | | 3844 | P45534 | 2/28/2024 | 50.69 | 131.83 | 131.83 |
| 0051580 | 0000559 | WORK FORCE QA | 001540 | | 2/28/2024 | 200.00 | | |
| | | | 001541 | | 2/28/2024 | 400.00 | | |
| | | | 001542 | | 2/28/2024 | 50.00 | 650.00 | 650.00 |
| 0051581 | 0002404 | WSMDD LAND TRUST | 001581 | | 2/28/2024 | 14,266.67 | | |

| CHECK NO | VENDOR NO | VENDOR NAME | VOUCHER NO | P.O. NO | DATE | VOUCHER AMOUNT | REMITTANCE AMOUNT | CHECK TOTAL |
|----------|-----------|------------------|------------|---------|-----------|----------------|-------------------|--------------|
| 0051581 | 0002404 | WSMDD LAND TRUST | 001582 | | 2/28/2024 | 2,750.00 | | |
| | | | 001583 | | 2/28/2024 | 833.33 | 17,850.00 | 17,850.00 |
| 0051582 | 0002500 | XEROX CORP | 001512 | | 2/28/2024 | 177.86 | | |
| | | | 001513 | | 2/28/2024 | 188.71 | | |
| | | | 3865 | P45671 | 2/28/2024 | 113.45 | 480.02 | 480.02 |
| 0051583 | 0006212 | ZOIE WHITLOCK | 3854 | P45627 | 2/28/2024 | 26.96 | 26.96 | 26.96 |
| | | | | | | TOTAL CHECKS | 165 | 3,046,331.40 |



COLUMBIA COUNTY BOARD OF COUNTY COMMISSIONERS AGENDA ITEM REQUEST FORM

The Board of County Commissioners meets the 1st and 3rd Thursday of each month in the Columbia County School Board Administrative Complex Auditorium, 372 West Duval Street, Lake City, Florida 32055. The first meeting of every month is at 9:30AM while the second meeting of every month takes place at 5:30PM. All agenda items are due in the Board's office one week prior to the meeting date.

Today's Date: 2/12/2024 Meeting Date: 3/7/2024

Department: Library

1. Nature and purpose of agenda item:

Requesting approval for the libraries to close on Saturday, March 30 and Sunday, March 31 for the Easter holiday, in addition to the Good Friday County holiday on Friday, March 29.

2. Recommended Motion/Action:

Motion to approve libraries to close on Saturday, March 30 and Sunday, March 31 for the Easter holiday, in addition to the Good Friday county holiday on Friday, March 29.

3. Fiscal impact on current budget.

This item has no effect on the current budget.

Columbia County Public Library
308 NW Columbia Avenue
Lake City, FL 32055
386-758-1018 * 386-758-2135 Fax

Katrina P. Evans, Library Director

MEMORANDUM

DATE: February 12, 2024

TO: David Kraus, County Manager

FR: Katrina Evans, Library Director

RE: Library Closings for Easter holiday

I would like to request approval by the Board of County Commissioners for the Library to close on Saturday, March 30, 2024, and on Sunday, March 31, 2024, for Easter, in addition to the Good Friday county holiday on Friday, March 29, 2024. Staff who would normally be scheduled to work on March 30 and March 31 would have the opportunity to work those hours at another time during the week or to use annual leave.

I would provide sufficient public notice in advance of the holiday closings. Please let me know if you need any further information from me. Thank you for your consideration.



COLUMBIA COUNTY BOARD OF COUNTY COMMISSIONERS AGENDA ITEM REQUEST FORM

The Board of County Commissioners meets the 1st and 3rd Thursday of each month in the Columbia County School Board Administrative Complex Auditorium, 372 West Duval Street, Lake City, Florida 32055. The first meeting of every month is at 9:30AM while the second meeting of every month takes place at 5:30PM. All agenda items are due in the Board's office one week prior to the meeting date.

Today's Date: 2/26/2024 Meeting Date: 3/7/2024

Department: Public Works

1. Nature and purpose of agenda item:

Requesting permission after the fact to remove these items from inventory.

- Asset# 14550 Zero Turn Mower
- EZ-Go Golf Cart Vin# A4991148504
- Refrigerator Body

2. Recommended Motion/Action:

Approve

3. Fiscal impact on current budget.

This item has no effect on the current budget.

District No. 1 - Ronald Williams
District No. 2 - Rocky Ford
District No. 3 - Robby Hollingsworth
District No. 4 - Everett Phillips
District No. 5 - Tim Murphy

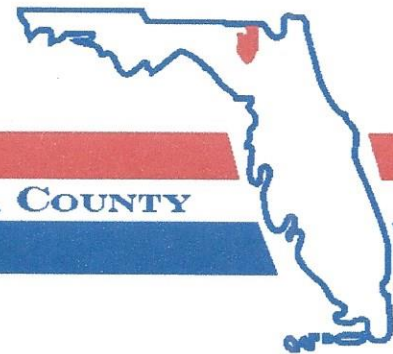

BOARD OF COUNTY COMMISSIONERS • COLUMBIA COUNTY

MEMORANDUM

TO: David Kraus, County Manager
FROM: Kevin Kirby, Assistant County Manager *16*
DATE: February 26, 2024
RE: Declaration of Surplus

The following item was included in the March 2 auction. I am requesting permission after the fact to remove these items from inventory.

- Asset# 14550 Zero Turn Mower
- EZ-Go Golf Cart Vin# A4991148504
- Refrigerator Body

Should you need any additional information, please feel free to contact me.

BOARD MEETS FIRST AND THIRD THURSDAY AT 5:30 P.M.

P.O. BOX 1529

LAKE CITY, FLORIDA 32056-1529

PHONE (386) 755-4100



**COLUMBIA COUNTY BOARD OF COUNTY COMMISSIONERS
AGENDA ITEM REQUEST FORM**

The Board of County Commissioners meets the 1st and 3rd Thursday of each month in the Columbia County School Board Administrative Complex Auditorium, 372 West Duval Street, Lake City, Florida 32055. The first meeting of every month is at 9:30AM while the second meeting of every month takes place at 5:30PM. All agenda items are due in the Board's office one week prior to the meeting date.

Today's Date: 2/13/2024 Meeting Date: 3/7/2024

Department: Public Works

1. Nature and purpose of agenda item:

Utility permit from AT&T requesting to run a cable along SE Pounds Hammock

2. Recommended Motion/Action:

Approve

3. Fiscal impact on current budget.

This item has no effect on the current budget.

**COLUMBIA COUNTY BOARD OF COUNTY COMISSIONERS
UTILITY PERMIT**

SE Pounds

Date: 1/30/24 Permit No. _____ County Road Hammock Rd Section No. _____

Permittee AT&T Authorized Agent, Tyler Scott, tyler.scott@byers.com

Address 9400 Historic Kings Rd, Jacksonville, FL 32257 Telephone Number 770-265-9706

Requesting permission from Columbia County, Florida, hereinafter called the County, to contract, operate and maintain ATT WILL BE PLACING 603' OF BURIED FIBER CABLE INSTALLED BY TRENCH METHOD @30"MIN FROM EXISTING HANDHOLE TO PROPOSED HANDHOLE.

Work Location: 423 SE Pounds Hammock Rd, Lake City, FL 32025

FROM: 423 SE Pounds Hammock Rd, Lake City, FL 32025 TO: 524 SE Pounds Hammock Rd. Lake Citv. FL 32025

Submitted for the Utility Owner by: Tyler Scott, Agent for AT&T *Tyler Scott* 1/30/24
Typed Name & Title Signature Date

1. Permittee declares that prior to filing this application it has determined the location of all existing utilities, both aerial and underground and the accurate locations are shown on the plans attached hereto and made a part of this application. Proposed work is within corporate limits of Municipality: YES () NO (). If YES: LAKE CITY () FORT WHITE (). A letter of notification was mailed on _____ to the following utility owners _____

Locates to be completed prior to construction

2. The Columbia County Public Works Director shall be notified twenty-four (24) hours prior to starting work and again immediately upon completion of work. The Public Works Director is Kevin Kirby, located at 607 NW Quenten St, Lake City LF, 32056 Telephone Number 386-752-5955/1019. The PERMITTEE's employee responsible for Maintenance of Traffic is _____ Telephone Number _____ (This name may be provided at the time of the 24 hour notice to starting work.)

3. This PERMITTEE shall commence actual construction in good faith within 30 days after issuance of permit, and shall be completed within 90 days after permitted work has begun. If the beginning date is more than 60 days from date of permit approval, then PERMITTEE must review the permit with the Columbia County Public Works Director to make sure no changes have occurred in the transportation facility that would affect the permitted construction.

4. The construction and maintenance of such utility shall not interfere with the property and rights of a prior PERMITTEE.

5. It is expressly stipulated that this permit is a license for permissive use only and that the placing of utilities upon public property pursuant to this permit shall not operate to create or vest any property right in said holder.

6. Pursuant to Section 337-403(1), Florida Statutes, whenever necessary for the construction, repair, improvement, maintenance, safe and efficient operation, alteration or relocation of all, or any portion of said transportation facility as determined by the Columbia County Public Works Director and/or County Engineer, any or all utilities and appurtenances authorized hereunder, shall be immediately removed from said transportation facility or reset or

relocated thereon as required by the Columbia County Public Works Director and/or County Engineer and at the expense of the PERMITTEE.

7. In case of non-compliance with the County's requirements in effect as of the approval date of this permit, this permit void and the facility will have to be brought into compliance or removed from the right of way at no cost to the County.

8. It is understood and agreed that the rights and privileges herein set out are granted only to the extent of the County's right, title and interest in the land to be entered upon and used by the PERMITTEE, and the PERMITTEE will, at all times, and to the extent permitted by law, assume all risk of and indemnify, defend, and save harmless Columbia County, Florida from any and all loss, damage, cost or expense arising in any manner on account of the exercise or attempted exercise by said PERMITTEE of the aforesaid right and privileges.

9. During construction, all safety regulations of the County shall be observed and the PERMITTEE must take measures, including pacing and the display of safety devices that may be necessary in order to safely conduct the public through the project area in accordance with the Federal Manual on Uniform Traffic Control Devices, as amended for highways.

10. Should the PERMITTEE be desirous of keeping its utilities in place and out of service, the PERMITTEE, by execution of this permit acknowledges its present and continuing ownership of its utilities located between _____ and _____ within the County's right of way as set forth above. PERMITTEE, as its sole expense, shall promptly remove said out of service utilities whenever Columbia County Public Works Director and/or County Engineer determines said removal is in the public interest.

11. Special instructions: Minimum cover of thirty inches (30") will be required at all locations. Columbia County will not be financially responsible for any damage to facilities with less than thirty inches (30") cover. Cables shall not be located within driveway ditches.

12. Additional Stipulations: _____

It is understood and agreed that commencement by the PERMITTEE is acknowledgment and acceptance of the binding nature of these specialist instructions.

Submitted By: Tyler Scott, Agent for AT&T
Permittee

Place Corporate Seal

Tyler Scott Permitting Engineer
Signature and Title

AT&T Authorized Agent
Attested

MAINTENANCE OF TRAFFIC PLANS INCLUDED WITH DRAWINGS

- CONSTRUCTION NOTES:
- 1) SIDEWALK TO BE REMOVED AND REPLACED AS NEEDED FOR BORE AND CORE
 - 2) RESTORATION PER CITY STANDARDS
 - 3) UTILITY LOCATIONS (TELEPHONE AND NON-TELEPHONE) ARE TO BEST INFORMATION AND APPROXIMATE ONLY. SEE OWNERS & CONTRACTORS FOR VERIFICATION OF EXACT LOCATION PRIOR TO WORK OPERATIONS.
 - 4) CALL FOR INSPECTIONS.
 - 5) RESTORE ALL EXCAVATIONS TO ORIGINAL OR BETTER.
 - 6) ALL TRENCHES WILL BE OPENED AND MAINTAINED FOLLOWING STANDARDS. IT IS RECOMMENDED THAT AND DIGGING, SOFT, SOFT DIGGING, VACUUM EXCAVATION ETC. BE USED, IN THE 30" TOLERANCE ZONE TO EXPOSE UNDERGROUND FACILITIES.
 - 7) CALL SUNSHINE STATE ONE CALL FLORIDA, INC AT 811 TO REQUEST A LOCATE OF ANY UNDERGROUND FACILITIES AT YOUR EXCAVATION SITE.
 - 8) CONTRACTOR TO PROVIDE A NOTICE OF COMMENCEMENT TO THE PERMIT AGENCY ENGINEERING DEPARTMENT 48 HOURS PRIOR TO BEGINNING CONSTRUCTION.
 - 9) MAINTAIN 18" VERTICAL CLEARANCE, 6' HORIZONTAL CLEARANCE BETWEEN EXISTING UTILITIES AND 36" COVER.

- Total Aerial Cable: 0
- Total Buried Cable: 593'
- Total # Of Bore: 0
- Total # Of Cabinets: 0
- Total # Of Handholes: 0
- Total # Of Down Gugs: 0
- Total # Of Anchors: 0
- Total # Of Sidewalk Panel Break & Restores: 0
- Cut & Restore: 0

SCOPE OF WORK:
ATT WILL BE PLACING 593' OF BURIED FIBER CABLE INSTALLED BY TRENCH METHOD @30" MIN DEPTH FROM EXISTING HANDHOLE TO PROPOSED HANDHOLE.

MOT (S) TO BE USED: 102-602, 102-603.

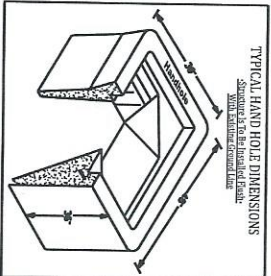
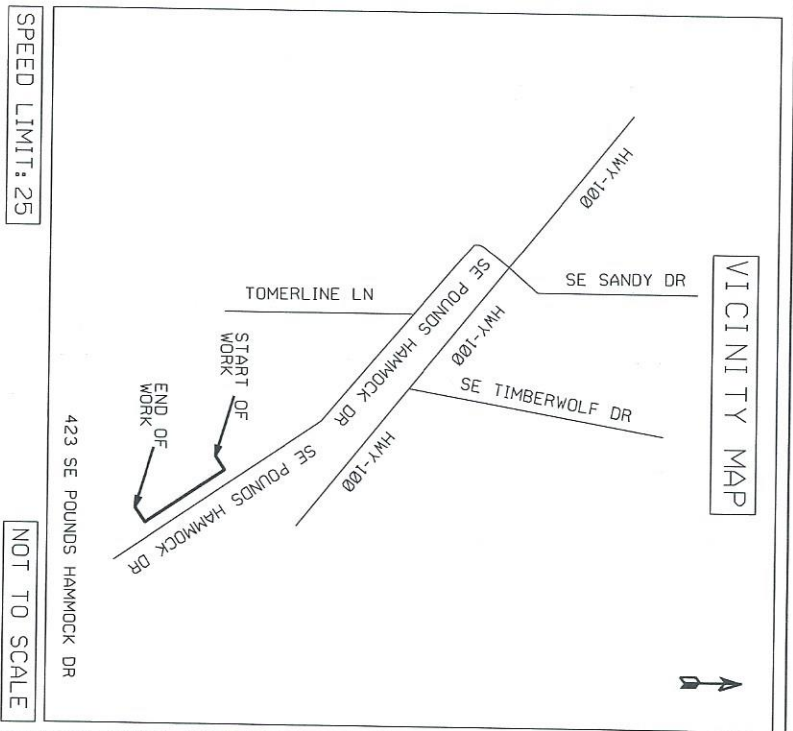

- DETAIL UTILITIES KEY
- ⊙ (C) CABLE
 - ⊙ (W) WATER
 - ⊙ (G) GAS
 - ⊙ (S) SEWER
 - ⊙ (T) TELEPHONE
 - ⊙ (P) POWER
 - ⊙ (A) AIR

CALL BEFORE YOU DIG

FLORIDA DIAL 811 or 1-800-432-4770

www.call811.com

1. IN THE COMPANIES RESPONSIBILITY TO OBTAIN THE LOCATION OF UTILITIES AND CONTACTING THE APPROPRIATE AGENCIES TO IDENTIFY THE LOCATION OF UTILITIES IN ADVANCE OF THE CONSTRUCTION OF THE PROJECT.

SEC TOWN - 12
RANGE - 04S
- 17E

SPEED LIMIT: 25

NOT TO SCALE

| Proposed | Existing | Description |
|----------|----------|-------------------------------|
| — B — | — B — | ASPH. CABLE |
| — B — | — B — | BURIED CABLE |
| ● | ○ | EST PALE |
| * | * | POWER POLE |
| ⊙ | ⊙ | CONCRETE POLE |
| △ | △ | ANCHOR & CUT |
| □ | □ | ENCLOSURE |
| □ | □ | ENCLOSURE |
| □ | □ | MANHOLE |
| □ | □ | TARGET RATED HANDHOLE 30x48 |
| — | — | PER/CONDUIT |
| — | — | CABLE MARKER |
| — | — | AGRAL SYNC WIRE |
| — | — | SP. CABLE |
| — | — | BURIED SYNC WIRE |
| — | — | BORE |
| — | — | CUT PAVEMENT |
| — | — | SP. CURE PIT |
| — | — | TRENCH LENGTHENING |
| — | — | FIBER OPTIC CABLE |
| — | — | CONCRETE TRENCH 1' WIDE, 3000 |
| — | — | POWER UTILITY |
| — | — | GAS UTILITY |
| — | — | WATER UTILITY |
| — | — | CABLE TELEVISION |
| — | — | SEWER UTILITY |
| — | — | ROSE UTILITY |
| — | — | STONE DRAIN |

ATTSE

PROPOSED TELEPHONE FACILITIES ON RIGHT OF WAY OF COLUMBIA COUNTY

SE POUNDS HAMMOCK DR

Exchange: 386752

Designer: PEELER, SCOTT A

Phone: 352-213-4188

Authorization: A02RKH

Dwg. 1 of 3

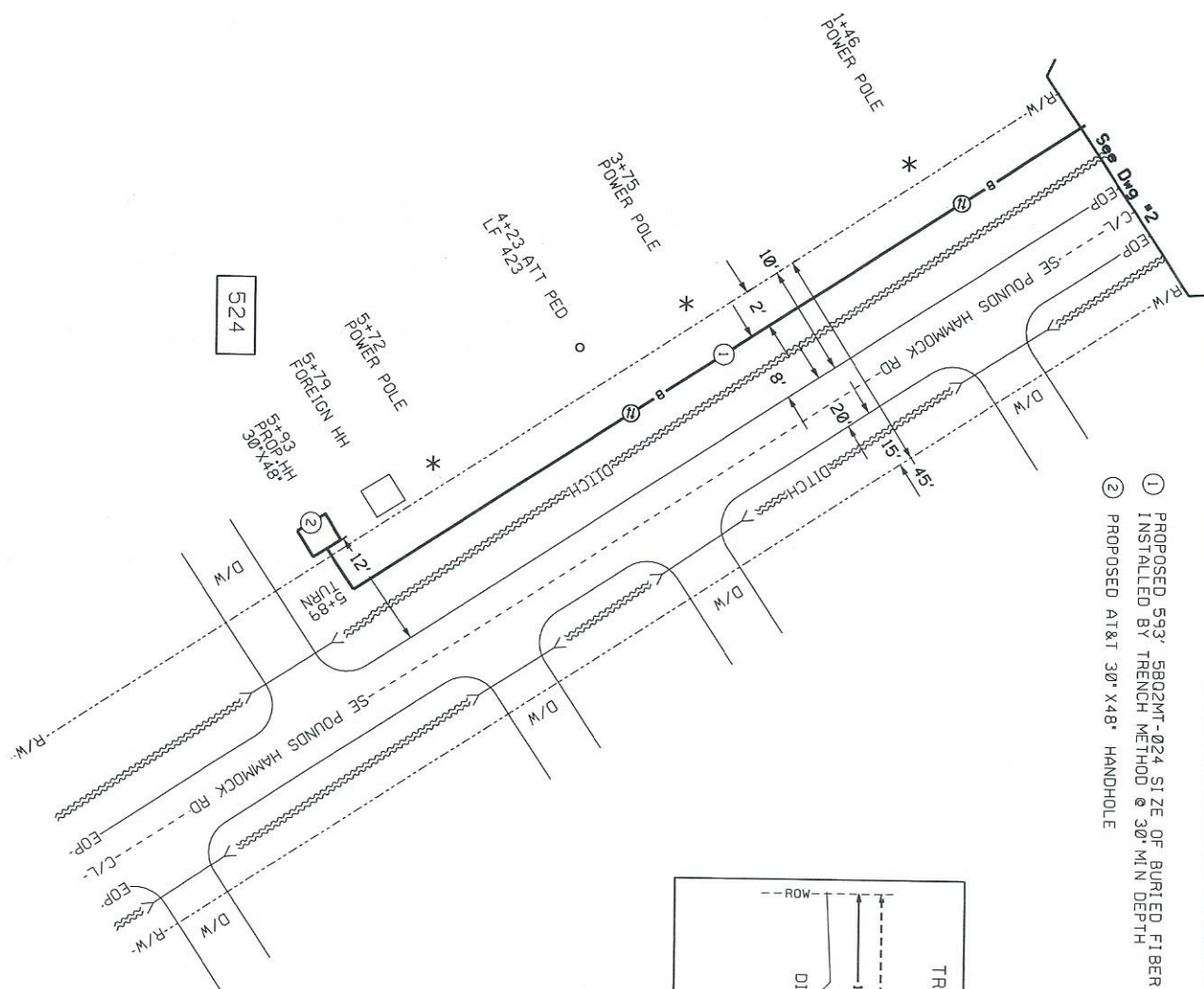

- ① PROPOSED 593' 5802MT-024 SIZE OF BURIED FIBER CABLE INSTALLED BY TRENCH METHOD @ 30" MIN DEPTH
- ② PROPOSED AT&T 30" X 48" HANDHOLE

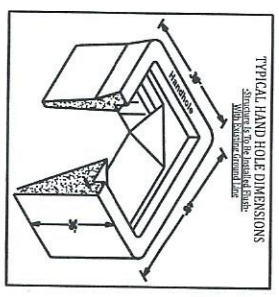
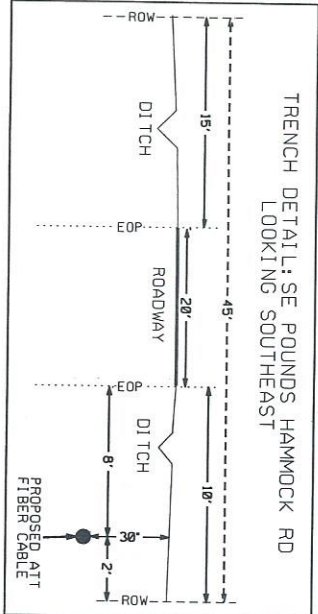

CALL BEFORE YOU DIG
 FLORIDA
 DIAL 811 OR
 1-800-432-4170
 www.dial811.com

TWO FULL BUSINESS DAYS BEFORE YOU DIG
 IT IS THE RESPONSIBILITY OF THE CALLER TO CONTACT THE APPROPRIATE AGENCIES TO DETERMINE THE LOCATION OF ALL UNDERGROUND UTILITIES IN THE AREA.

18" MIN SEPARATION
 BETWEEN UTILITIES

MOT'S USED:
 102-602,
 102-603.

| | |
|--|-----------------|
| ATTSE | |
| PROPOSED TELEPHONE FACILITIES ON RIGHT OF WAY OF COLUMBIA COUNTY | |
| SE POUNDS HAMMOCK DR | |
| Exchange: | 386752 |
| Designer: | PEELER, SCOTT A |
| Phone: | 352-213-4188 |
| Authorization: | A02RKH |
| DWG. 3 | of 3 |



NOTE:

1. This Index applies to Two-Lane, Two-Way and Multi-Lane Roadways, including Medians or divided roadways, with work on the shoulder.

2. L = Taper Length

X = Work Zone Sign Spacing

B = Buffer Length

See Index 102-600 for "L", "X", "B", and channelizing device spacing values.

3. Where work activities are between 2' and 15' from the edge of traveled way, the Engineer may omit signs and channelizing devices for work operations 60 minutes or less.

4. When four or more work vehicles enter the through traffic lanes in a one hour period (excluding establishing and terminating the work area), use a flagger or lane closure to accommodate work vehicle ingress and egress.

5. For work less than 2' from the traveled way and work zone speed is greater than 45 MPH, use a lane closure.

6. The "Speeding Fines Doubled When Workers Present" signs (MOT-13-06) and End Road Work" Signs (G20-2) along with the associated work zone sign spacing distances may be omitted when the work operation is in place for 24 hours or less.

7. Temporary pavement markings may be omitted when the work operation is in place for 3 days or less.

8. Omit "Shoulder Closed" signs (W21-5a) along with associated work zone sign spacing distances for work on the median.

9. When there is no paved shoulder, the "Worker" sign (W21-1) may be used instead of the "Shoulder Closed" sign (W21-5a).

SYMBOLS:



Work Area

Channelizing Device (See Index 102-600)

Work Zone Sign

Lane Identification and Direction of Traffic

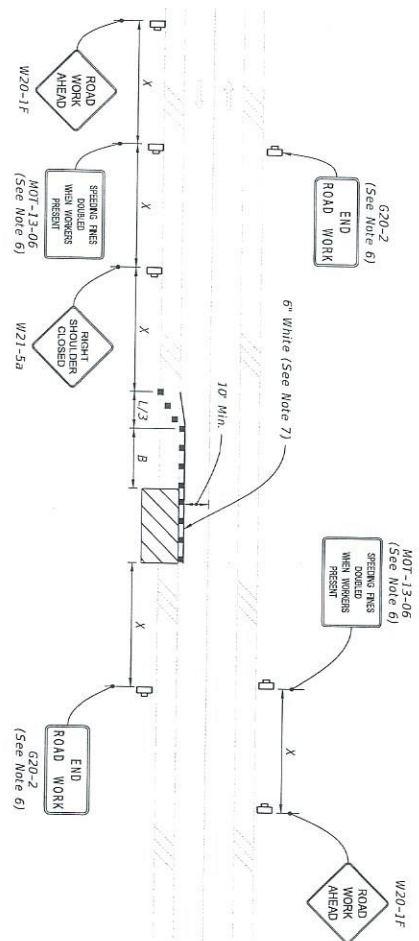

**TWO-LANE ROADWAY
SHOULDER WORK LESS THAN 2' FROM THE TRAVELED WAY
WITH WORK ZONE SPEED OF 45 MPH OR LESS**

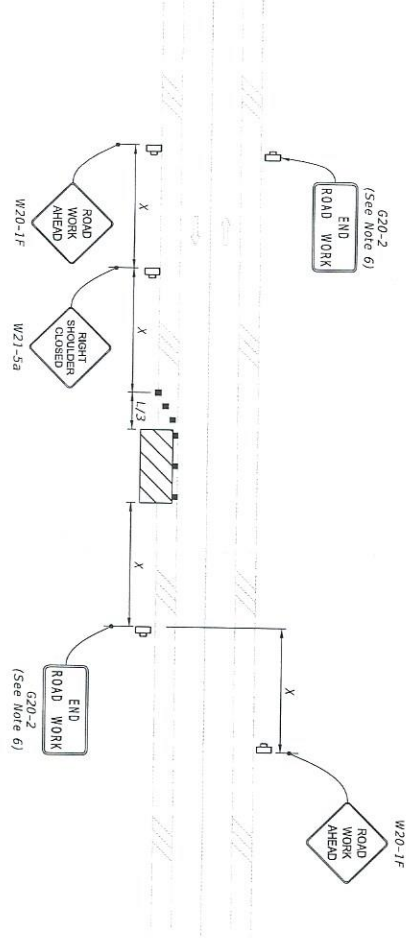

**TWO-LANE ROADWAY
SHOULDER WORK BETWEEN 2' AND 15' FROM THE TRAVELED WAY**





| LAST REVISION | DESCRIPTION | INDEX | SHEET |
|---------------|-------------|---------|--------|
| 11/01/21 | | 102-602 | 1 OF 2 |



FY 2023-24
STANDARD PLANS

TWO-LANE AND MULTILANE, WORK ON SHOULDER

| | | | | | |
|---------------------------|--------------|--------------------------------------|--|------------------|-----------------|
| LAST REVISION 11/01/20 | DESCRIPTION: | FDOT FY 2023-24 STANDARD PLANS | TWO-LANE AND MULTILANE, WORK ON SHOULDER | INDEX 102-602 | SHEET 2 OF 2 |
|---------------------------|--------------|--------------------------------------|--|------------------|-----------------|

- SYMBOLS:**
-  Work Area
 -  Channelizing Device (See Index 102-600)
 -  Work Zone Sign
 -  Lane Identification and Direction of Traffic

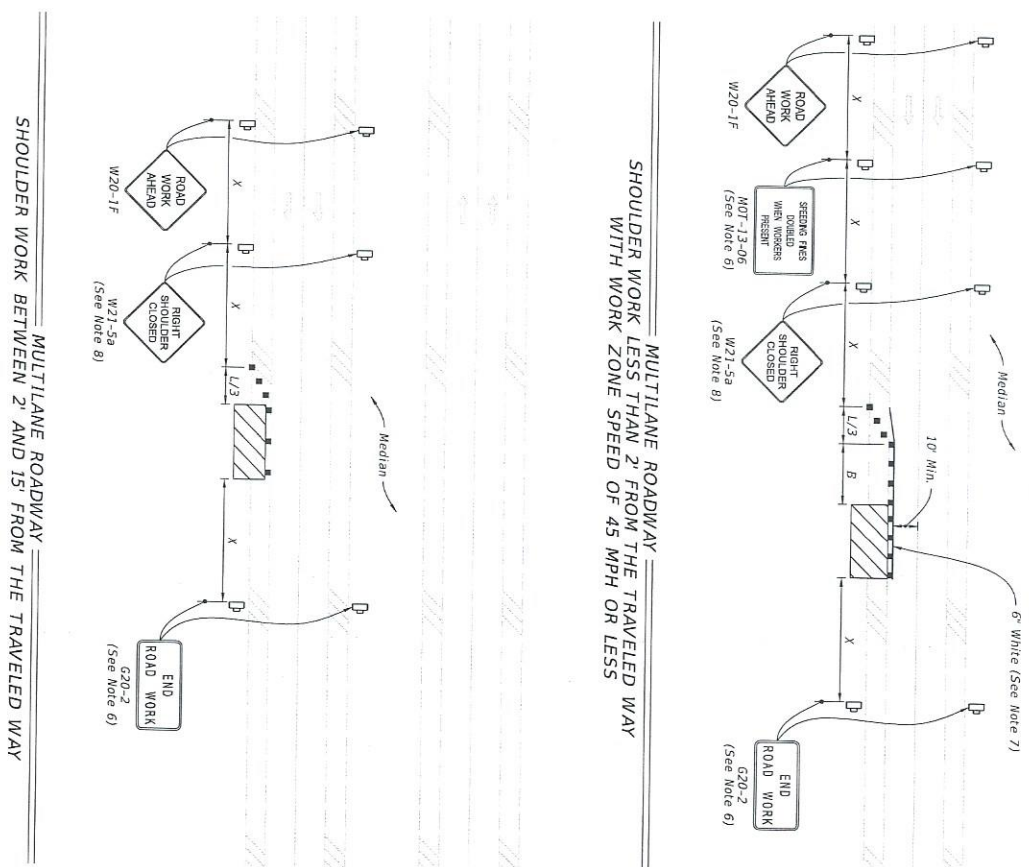

MULTILANE ROADWAY
SHOULDER WORK LESS THAN 2' FROM THE TRAVELED WAY
WITH WORK ZONE SPEED OF 45 MPH OR LESS

| | | | | | | |
|---------------------------|--|------------------------|------------|---|------------------|-----------------|
| LAST REVISION 11/01/21 | DESCRIPTION: Lane Identification and Direction of Traffic | FDOT STANDARD PLANS | FY 2023-24 | TWO-LANE, TWO-WAY WORK WITHIN THE TRAVEL WAY | INDEX 102-603 | SHEET 1 of 2 |
|---------------------------|--|------------------------|------------|---|------------------|-----------------|

- SYMBOLS:**
- ▨ Work Area
 - ▤ Channelizing Device (See Index 102-600)
 - Work Zone Sign
 - Flagger
- Line Identification and Direction of Traffic

- When flaggers are the sole means of one-way control, the flaggers must be in sight of each other or in direct communication at all times.
- Use temporary raised rumble strips when the existing posted speed is 55 mph or greater and the work duration is greater than 60 minutes. If temporary raised rumble strips are not used, omit "Rumble Strips Ahead" signs (MOT-18-10) and associated work zone sign spacing.
 - Additional one-way control may be provided by the following means:
 - Flag-carrying vehicle
 - Official vehicle
 - Pilot vehicles
 - Traffic signals

- Optional, use "Flagger Ahead" sign with symbol (W20-71) instead of "Flagger Ahead" sign with text (W20-7A).
- The "Speeding Fines Doubled When Workers Present" signs (MOT-13-06) and "End Road Work" signs (G20-2), along with associated work zone sign spacing, may be omitted when the work operation will be in place for 24 hours or less.
- Automated Flagger Assistance Devices (AFADs) may be used in accordance with Specification Sections 102.990 and the APL vendor drawings.
- Railroad Crossings:
 - If an active railroad crossing is located closer to the work area than the queue length plus 300 feet, extend the Buffer Space as shown on Sheet 2.
 - If the queuing of vehicles across an active railroad crossing cannot be avoided, provide a uniformed traffic control officer or flagger at the highway-rail grade crossing to prevent vehicles from stopping within the highway-rail grade crossing, even if automatic train warning devices are in place.

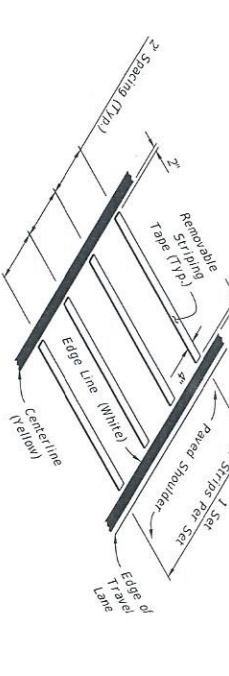
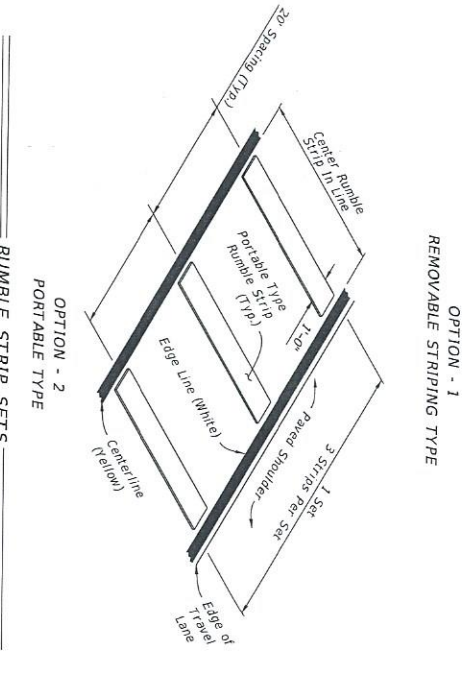
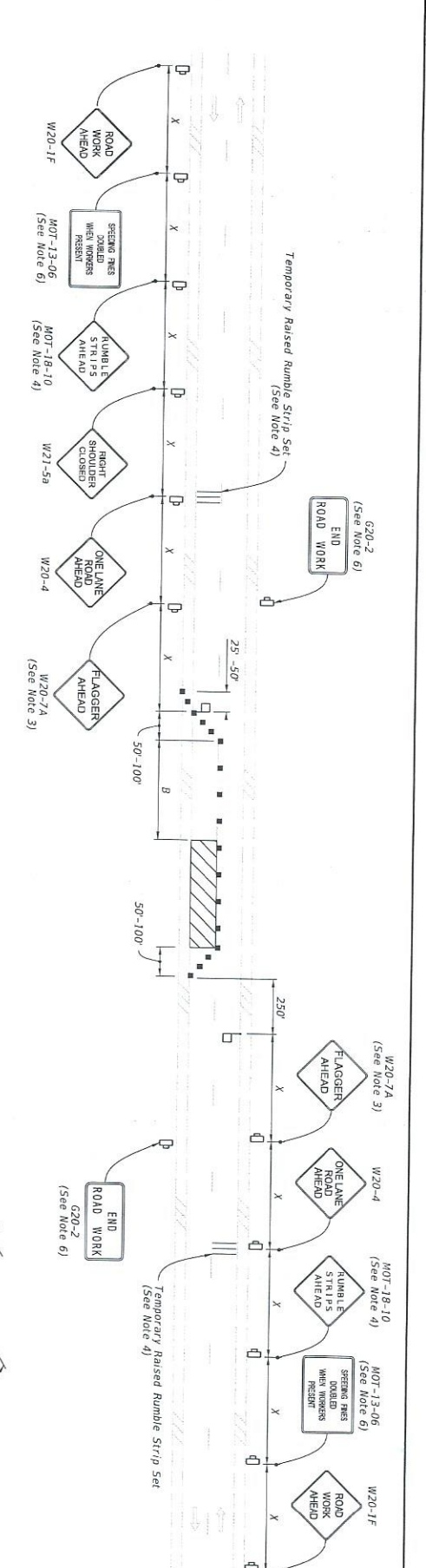

| | | | | | |
|---------------------------|--------------|------------------------------|---|------------------|-----------------|
| LAST REVISION 11/01/21 | DESCRIPTION: | FY 2023-24 STANDARD PLANS | TWO-LANE, TWO-WAY WORK WITHIN THE TRAVEL WAY | INDEX 102-603 | SHEET 2 of 2 |
|---------------------------|--------------|------------------------------|---|------------------|-----------------|

SPECIAL CONDITIONS

TEMPORARY LANE SHIFT TO SHOULDER WHEN WORK AREA ENCROACHES ON THE CENTERLINE
(For Work Operations in place 24 Hours or Less)

- SYMBOLS:**
- Work Area
 - Channelizing Device (See Index 102-600)
 - Work Zone Sign
 - Flagger
 - Lane Identification and Direction of Traffic

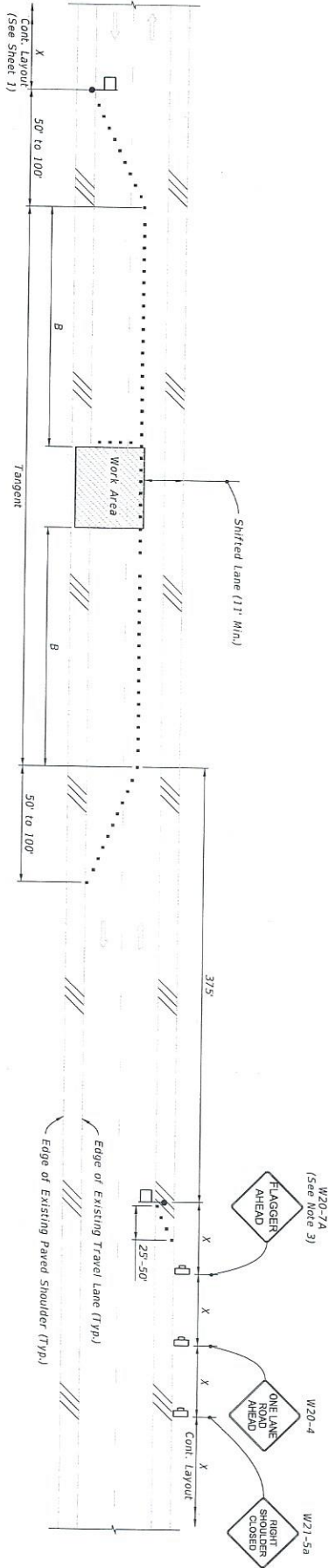

TEMPORARY RAILROAD CROSSING BUFFER SPACE EXTENSION

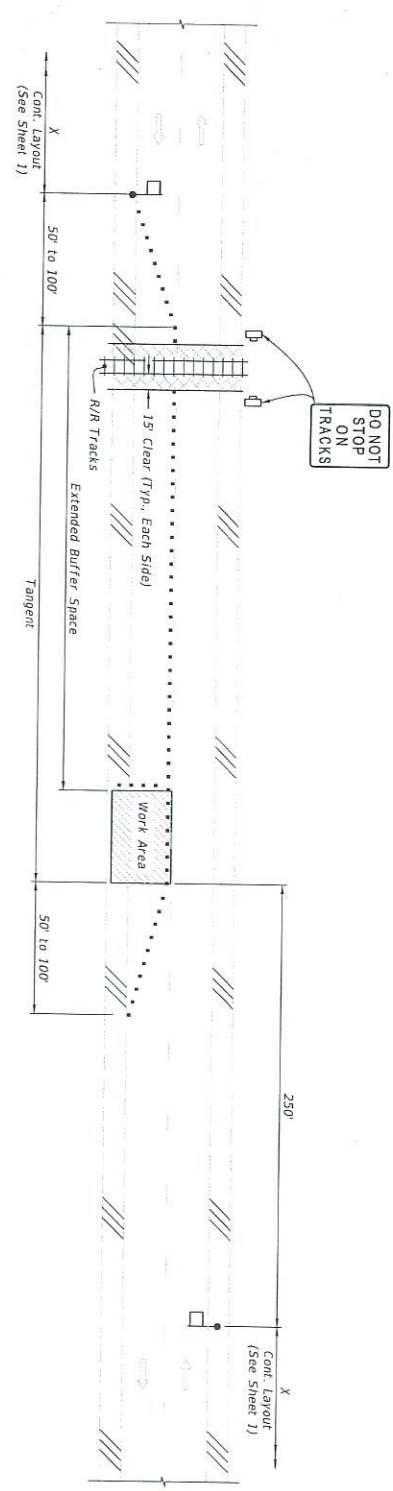



COLUMBIA COUNTY BOARD OF COUNTY COMMISSIONERS AGENDA ITEM REQUEST FORM

The Board of County Commissioners meets the 1st and 3rd Thursday of each month in the Columbia County School Board Administrative Complex Auditorium, 372 West Duval Street, Lake City, Florida 32055. The first meeting of every month is at 9:30AM while the second meeting of every month takes place at 5:30PM. All agenda items are due in the Board's office one week prior to the meeting date.

Today's Date: 2/15/2024 Meeting Date: 3/7/2024

Department: Public Works

1. Nature and purpose of agenda item:

Utility permit from AT&T requesting to run a cable along SW Upchurch Ave.

2. Recommended Motion/Action:

Approve

3. Fiscal impact on current budget.

This item has no effect on the current budget.

**COLUMBIA COUNTY BOARD OF COUNTY COMISSIONERS
UTILITY PERMIT**

Date: 2/12/24 Permit No. _____ County Road _____ Section No. 16

Permittee Christina Henriques for AT&T

Address 188 Hurricane Shoals Rd NE Lawrenceville, GA 30046 Telephone Number 407-625-1006

Requesting permission from Columbia County, Florida, hereinafter called the County, to contract, operate and maintain SW Upchurch Ave (near intersection of SW Upchurch Ave and SW State Rd 247)

FROM: SW State Rd 247 TO: SW Kimberly Ln

Submitted for the Utility Owner by Christina Henriques Permit Coord. Christina Henriques 2/12/2024
Typed Name & Title Signature Date

1. Permittee declares that prior to filing this application it has determined the location of all existing utilities, both aerial and underground and the accurate locations are shown on the plans attached hereto and made a part of this application. Proposed work is within corporate limits of Municipality: YES () NO (). If YES: LAKE CITY () FORT WHITE (). A letter of notification was mailed on 2/9/2024 to the following utility owners AT & T/DISTRIBUTION, CLAY ELECTRIC LAKE CITY DISTRICT, COMCAST CABLE COMMUNICATIONS

2. The Columbia County Public Works Director shall be notified twenty-four (24) hours prior to starting work and again immediately upon completion of work. The Public Works Director is Kevin Kirby, located at 607 NW Quinten St, Lake City, FL 32055 Telephone Number 386-758-1019. The PERMITTEE's employee responsible for Maintenance of Traffic is Chris Wilkinson Telephone Number 386-216-1482 (This name may be provided at the time of the 24 hour notice to starting work.)

3. This PERMITTEE shall commence actual construction in good faith within 30 days after issuance of permit, and shall be completed within 120 days after permitted work has begun. If the beginning date is more than 60 days from date of permit approval, then PERMITTEE must review the permit with the Columbia County Public Works Director to make sure no changes have occurred in the transportation facility that would affect the permitted construction.

4. The construction and maintenance of such utility shall not interfere with the property and rights of a prior PERMITTEE.

5. It is expressly stipulated that this permit is a license for permissive use only and that the placing of utilities upon public property pursuant to this permit shall not operate to create or vest any property right in said holder.

6. Pursuant to Section 337-403(1), Florida Statutes, whenever necessary for the construction, repair, improvement, maintenance, safe and efficient operation, alteration or relocation of all, or any portion of said transportation facility as determined by the Columbia County Public Works Director and/or County Engineer, any or all utilities and appurtenances authorized hereunder, shall be immediately removed from said transportation facility or reset or

relocated thereon as required by the Columbia County Public Works Director and/or County Engineer and at the expense of the PERMITTEE.

7. In case of non-compliance with the County's requirements in effect as of the approval date of this permit, this permit void and the facility will have to be brought into compliance or removed from the right of way at no cost to the County.

8. It is understood and agreed that the rights and privileges herein set out are granted only to the extent of the County's right, title and interest in the land to be entered upon and used by the PERMITTEE, and the PERMITTEE will, at all times, and to the extent permitted by law, assume all risk of and indemnify, defend, and save harmless Columbia County, Florida from any and all loss, damage, cost or expense arising in any manner on account of the exercise or attempted exercise by said PERMITTEE of the aforesaid right and privileges.

9. During construction, all safety regulations of the County shall be observed and the PERMITTEE must take measures, including pacing and the display of safety devices that may be necessary in order to safely conduct the public through the project area in accordance with the Federal Manual on Uniform Traffic Control Devices, as amended for highways.

10. Should the PERMITTEE be desirous of keeping its utilities in place and out of service, the PERMITTEE, by execution of this permit acknowledges its present and continuing ownership of its utilities located between SW State Road 247 and SW Kimberly Ln within the County's right of way as set forth above. PERMITTEE, as its sole expense, shall promptly remove said out of service utilities whenever Columbia County Public Works Director and/or County Engineer determines said removal is in the public interest.

11. Special instructions: Minimum cover of thirty inches (30") will be required at all locations. Columbia County will not be financially responsible for any damage to facilities with less than thirty inches (30") cover. Cables shall not be located within driveway ditches.

12. Additional Stipulations: AT&T job A02P59G proposes to place via DIRECT BURY 160' OF 24CT
buried cable via trench method.

It is understood and agreed that commencement by the PERMITTEE is acknowledgment and acceptance of the binding nature of these specialist instructions.

Submitted By: Christina Henriques
Permittee

Place Corporate Seal

Christina Henriques Permit Coord.
Signature and Title

Attested

Utilities Permit
Page three
Revised: 8/17/00

Recommended for Approval:

Signature: _____ *[Handwritten Signature]*

Title: _____ *Asst. County Manager*

Date: _____ *02-15-04*

Approval by Board of County Commissioners, Columbia County, Florida:

YES () NO ()

Date Approved: _____

Chairman's Signature: _____

VICINITY MAP

NOT TO SCALE

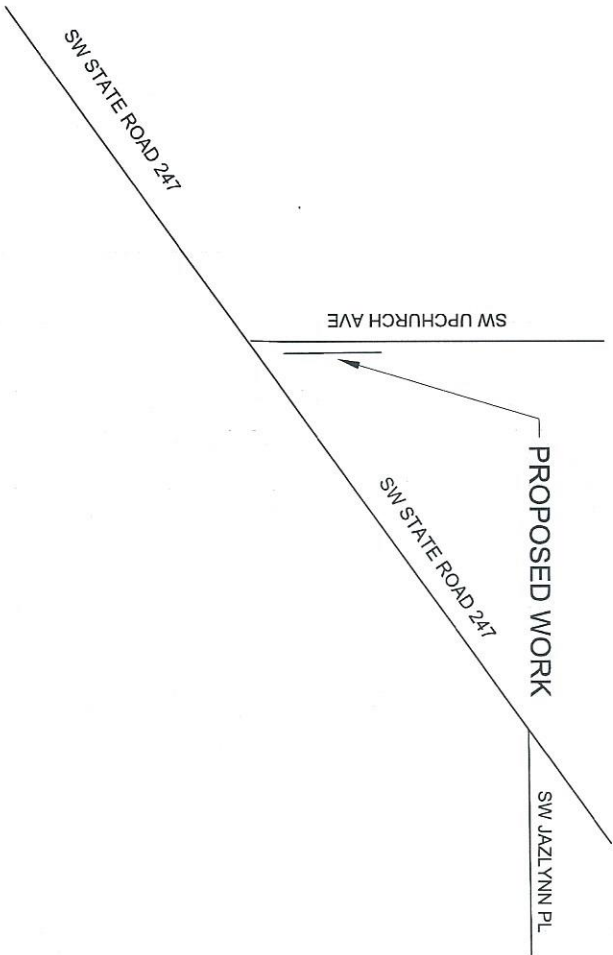

SYMBOL LEGEND

| Proposed | Existing | Description |
|----------|----------|---------------------|
| — | — | AERIAL CABLE |
| —B— | —B— | BURIED CABLE |
| — — | — — | PIPE/CONDUIT |
| --- | N/A | DBORE |
| * | * | POWER POLE |
| ○ | ○ | A/T & T POLE |
| —A— | —A— | GUY & ANCHOR |
| □ | □ | HANDHOLE MANHOLE |
| □ | □ | BORE PIT (3'x3'x3') |

CONSTRUCTION NOTES:

APPLICANT RESPONSIBLE FOR ALL UTILITY LOCATES AND PROPER NOT WHILE WORKING WITHIN AND/OR ADJACENT TO THE ROW.

ALL WORK WHILE WITHIN THE ROW SHALL MAINTAIN PROPER CLEARANCE AND BE INSTALLED IN ACCORDANCE WITH FOOT AND COUNTY SPECIFICATIONS, INCLUDING DIRECTIONAL BORES. IF THE WORK SPACE EXTENDS ACROSS A CROSSWALK, THE CROSSWALK SHOULD BE CLOSED USING THE INFORMATION IN INDEX NO. 660.

ALL DIRECTIONAL BORES SHALL BE IN ACCORDANCE WITH THE FOOT STANDARD SPECIFICATIONS FOR ROAD AND BRIDGE CONSTRUCTION SECTION 555, DIRECTIONAL BORES AND THE FOOT UTILITIES ACCOMMODATION MANUAL.

ALL DISTURBED AREAS WITHIN THE CITY ROW SHALL BE SODED WITH THE SAME SO2, SEED AND MULCH IS NOT ACCEPTABLE.

ANY DAMAGE TO THE EXISTING INFRASTRUCTURE, INCLUDING IRRIGATION, SIDEWALKS, CURBING AND UNDERMINING ARE TO BE RESTORED TO COUNTY DETAIL PRIOR TO FINAL INSPECTION. SIDEWALK PATCHING IS NOT ACCEPTABLE. ALL CONCRETE REPLACEMENT MUST BE JOINT TO JOINT.

MAINTAIN EROSION AND SEDIMENT CONTROL ALONG LENGTH OF TRENCH; OR CURB INLET PROTECTION. ANY DEBRIS SHALL BE REMOVED FROM THE CURB AND GUTTER. SAFETY FENCING SHALL BE USED BETWEEN SIDEWALK AND ANY OPEN TRENCH.

MOT(S) TO BE USED: 1024603

- TOTAL AERIAL CABLE: 0
- TOTAL BURIED CABLE: 160'
- TOTAL BURIED CONDUIT: 0
- TOTAL NUMBER OF BORES (ALL TYPES): 0
- TOTAL NUMBER OF CABINETS: 0
- TOTAL NUMBER OF HANDHOLES: 0
- TOTAL NUMBER OF GUYS: 0
- TOTAL NUMBER OF ANCHORS: 0

SCOPE OF WORK:

DIRECT BURY 160' OF 24CT BURIED FIBER CABLE BY METHOD OF TRENCH.

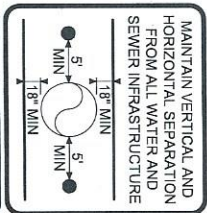

IT IS THE CONTRACTORS RESPONSIBILITY TO CONTACT UTILITY COMPANIES PRIOR TO ANY CONSTRUCTION AS THE LOCATION OF UTILITIES SHOWN ON THIS PLAT ARE APPROXIMATE AND POSSIBLY INCOMPLETE. THEREFORE CERTIFICATION TO THE LOCATION OF ALL UNDERGROUND UTILITIES IS WITHHELD.



PROPOSED TELEPHONE FACILITIES ON RIGHT OF WAY OF COLUMBIA CO

4176A SW UPCHURCH AVE

N/P/ANNX: 386752

Designer: PEELER, SCOTT A

Phone: 352-213-4188

Project #: A029596

Sheet #: PRINT 1 OF 2

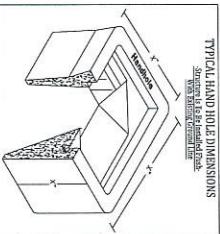

② 160' PROPOSED BURIED FIBER CABLE 024 CT TRENCHED @30"

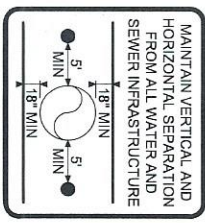
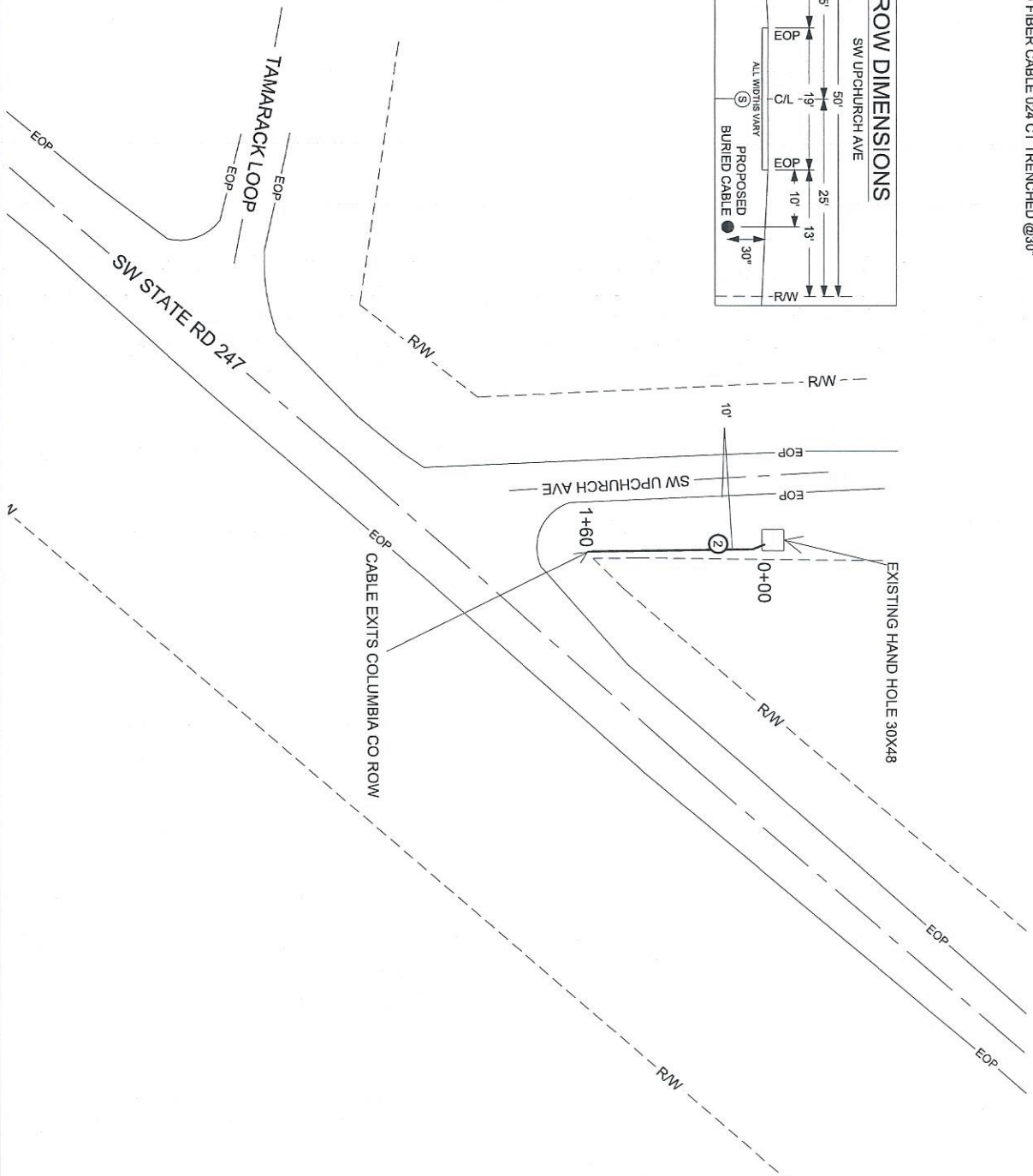
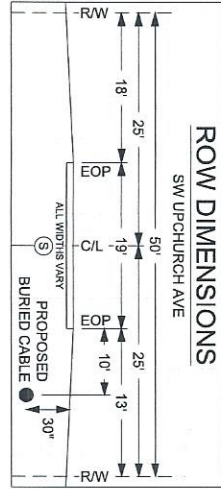

AT&T
 PROPOSED TELEPHONE FACILITIES
 ON RIGHT OF WAY OF
 COLUMBIA CO

4176A SW UPCHURCH AVE

NPANXX: 386752
 Designer: PEELER, SCOTT A
 Phone: 352-213-4188
 Project #: A02P59G
 Sheet #: PRINT 2 OF 2

COLUMBIA CO PERMIT

AT&T JOB NUMBER: A02P59G

MOTS:102-603





EXISTING HAND HOLE 30X48

SW UPCHURCH RD LOOKING S. E.

SW STATE ROAD 247

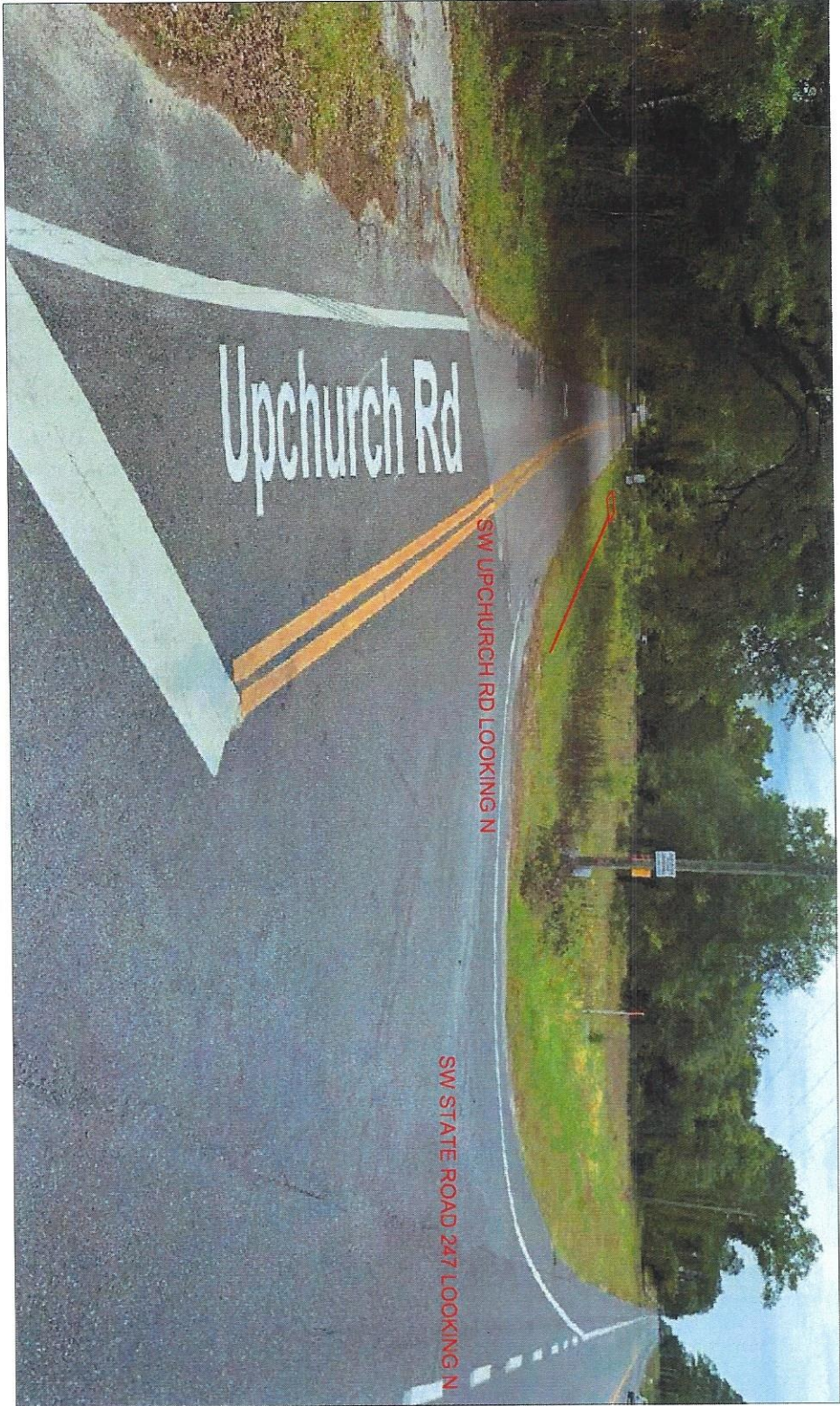





LAST REVISION 11/01/21

DESCRIPTION: REVISION

FDOT STANDARD PLANS

FY 2023-24

WORK WITHIN THE TRAVEL WAY

INDEX 102-603

SHEET 1 OF 2

- SYMBOLS:**
- ▨ Work Area
 - ▤ Channelizing Device (See Index 102-600)
 - Work Zone Sign
 - ◀ Flagger
- Lane Identification and Direction of Traffic

When flaggers are the sole means of one-way control, the flaggers must be in sight of each other or in direct communication at all times.

5. Additional one-way control may be provided by the following means:
 - a. Flag-carrying vehicle
 - b. Official vehicle
 - c. Pilot vehicles
 - d. Traffic signals

4. Use temporary raised rumble strips when the existing posted speed is 55 mph or greater and the work duration is greater than 60 minutes. If temporary raised rumble strips are not used, omit "Rumble Strips Ahead" signs (MOT-18-10) and associated work zone sign spacing.

3. Optionally, use "Flagger Ahead" sign with symbol (W20-7) instead of "Flagger Ahead" sign with text (W20-7A).

2. L = Trailer Length
B = Buffer Length
X = Work Zone Sign Spacing
See Index 102-600 for "L", "B", "X" and channelizing device spacing values.

1. This index applies to Two-Lane, Two-Way Roadways with work within the traveled way.

6. The "Speeding Fines Doubled When Workers Present" signs (MOT-13-06) and "End Road Work" signs (G20-2), along with associated work zone sign spacing, may be omitted when the work operation will be in place for 24 hours or less.
7. Automated Flagger Assistance Devices (AFADS) may be used in accordance with Specification Sections 102, 990 and the APL vendor drawings.
8. Railroad Crossings:
 - a. If an active railroad crossing is located closer to the Work Area than the queue length plus 300 feet, extend the Buffer Space as shown on Sheet 2.
 - b. If the queuing of vehicles across an active railroad crossing cannot be avoided, provide a uniformed traffic control officer or flagger at the highway-rail grade crossing to prevent vehicles from stopping within the highway-rail grade crossing, even if automatic train warning devices are in place.

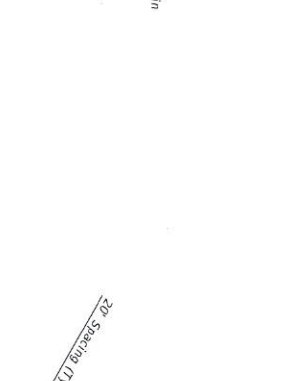
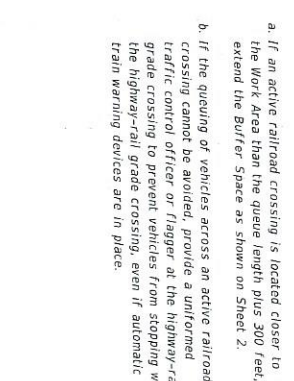
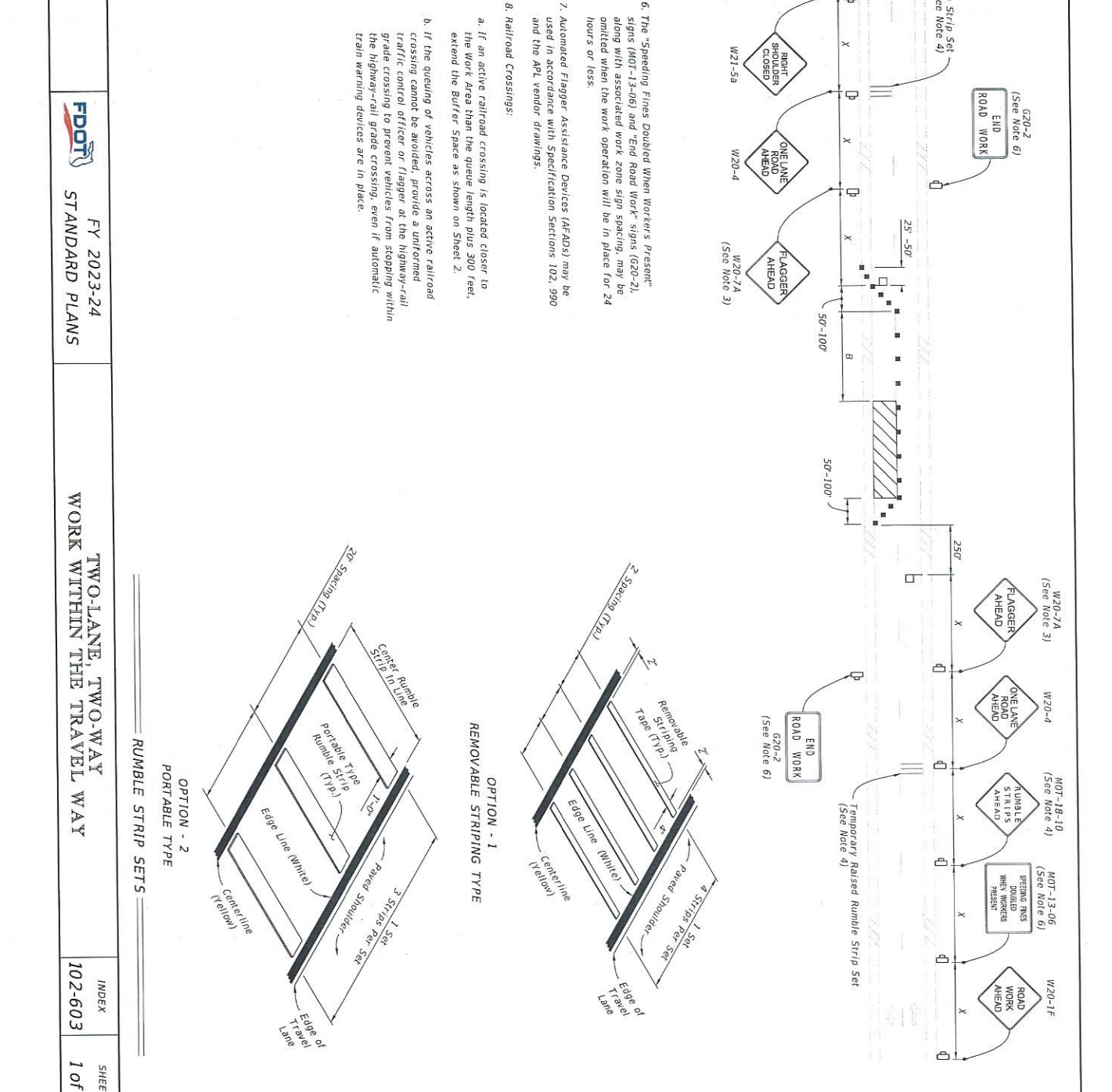

RUMBLE STRIP SETS

LAST REVISION 11/01/21

REVISION DESCRIPTION:

FDOT

FY 2023-24 STANDARD PLANS

TWO-LANE, TWO-WAY WORK WITHIN THE TRAVEL WAY

INDEX 102-603

SHEET 2 of 2

SPECIAL CONDITIONS

- SYMBOLS:**
- Work Area
 - Channelizing Device (See Index 102-600)
 - Work Zone Sign
 - Flagger
 - Lane Identification and Direction of Traffic

TEMPORARY LANE SHIFT TO SHOULDER WHEN WORK AREA ENCROACHES ON THE CENTERLINE
(For Work Operations in place 24 Hours or Less)

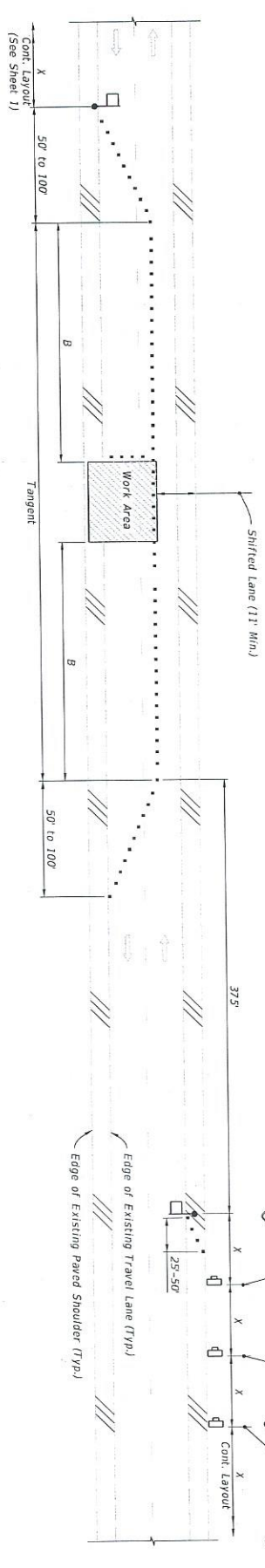

TEMPORARY RAILROAD CROSSING BUFFER SPACE EXTENSION

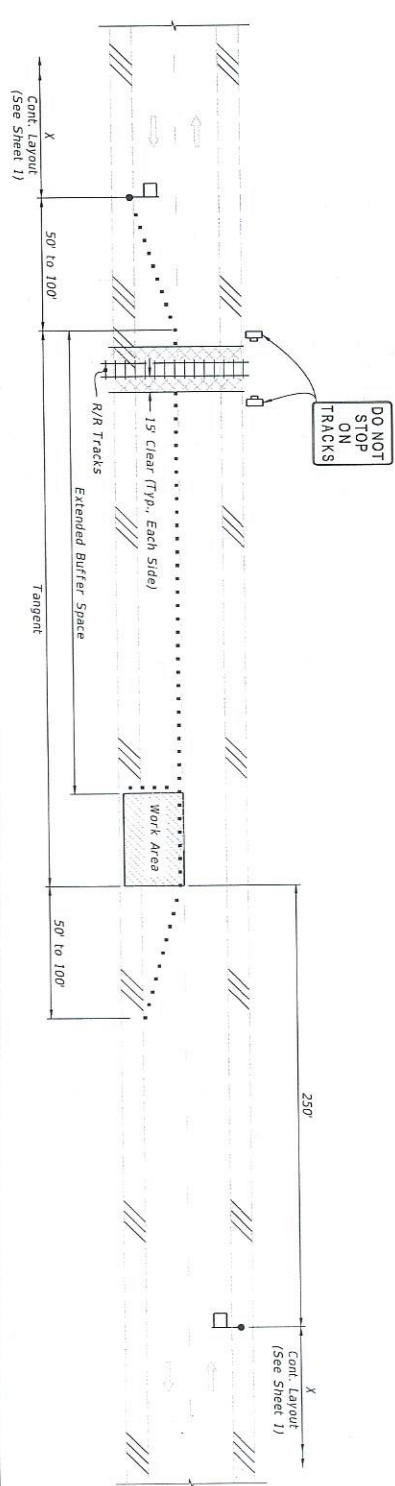



**COLUMBIA COUNTY BOARD OF COUNTY COMMISSIONERS
AGENDA ITEM REQUEST FORM**

The Board of County Commissioners meets the 1st and 3rd Thursday of each month in the Columbia County School Board Administrative Complex Auditorium, 372 West Duval Street, Lake City, Florida 32055. The first meeting of every month is at 9:30AM while the second meeting of every month takes place at 5:30PM. All agenda items are due in the Board's office one week prior to the meeting date.

Today's Date: 2/29/2024 Meeting Date: 3/7/2024

Department: Public Works

1. Nature and purpose of agenda item:

Utility permit from M.A. Mortenson Company requesting to run a cable along SW Wilson Springs Road

2. Recommended Motion/Action:

Approve

3. Fiscal impact on current budget.

This item has no effect on the current budget.

**COLUMBIA COUNTY BOARD OF COUNTY COMISSIONERS
UTILITY PERMIT**

Date: 2/22/2024 Permit No. _____ County Road SW Wilson Springs Road Section No. _____

Permittee M.A. Mortenson Company

Address 700 Meadow Lane North, Minneapolis, MN 55422 Telephone Number 661-860-2176

Requesting permission from Columbia County, Florida, hereinafter called the County, to contract, operate and maintain Two (2) proposed Horizontal Directional Drill (HDD) Bore placement for electric cables in conduits under SW Wilson Springs Road approximately 1,500 feet west of State Road 47 at min. depth of 5'. See EX-1 Crossing Exhibit.

Utility Owner: FRP Columbia County Solar, LLC Utility Owner Contact : Spencer Bechtel - (913)927-7202

FROM: 35.8301139, -090.0063112 TO: 35.8302742, -090.0064262

Submitted for the Utility Owner by: Ryley Rathman, Field Engineer  2/23/2024
Typed Name & Title Signature Date

1. Permittee declares that prior to filing this application it has determined the location of all existing utilities, both aerial and underground and the accurate locations are shown on the plans attached hereto and made a part of this application. Proposed work is within corporate limits of Municipality: YES () NO (). If YES: LAKE CITY () FORT WHITE (). A letter of notification was mailed on _____ to the following utility owners _____

2. The Columbia County Public Works Director shall be notified twenty-four (24) hours prior to starting work and again immediately upon completion of work. The Public Works Director is _____, located at _____ Telephone Number _____ The PERMITTEE's employee responsible for Maintenance of Traffic is Ryley Rathman Telephone Number 847-606-6505 (This name may be provided at the time of the 24 hour notice to starting work.)

3. This PERMITTEE shall commence actual construction in good faith within _____ days after issuance of permit, and shall be completed within _____ days after permitted work has begun. If the beginning date is more than 60 days from date of permit approval, then PERMITTEE must review the permit with the Columbia County Public Works Director to make sure no changes have occurred in the transportation facility that would affect the permitted construction.

4. The construction and maintenance of such utility shall not interfere with the property and rights of a prior PERMITTEE.

5. It is expressly stipulated that this permit is a license for permissive use only and that the placing of utilities upon public property pursuant to this permit shall not operate to create or vest any property right in said holder.

6. Pursuant to Section 337-403(1), Florida Statutes, whenever necessary for the construction, repair, improvement, maintenance, safe and efficient operation, alteration or relocation of all, or any portion of said transportation facility as determined by the Columbia County Public Works Director and/or County Engineer, any or all utilities and appurtenances authorized hereunder, shall be immediately removed from said transportation facility or reset or

relocated thereon as required by the Columbia County Public Works Director and/or County Engineer and at the expense of the PERMITTEE.

7. In case of non-compliance with the County's requirements in effect as of the approval date of this permit, this permit void and the facility will have to be brought into compliance or removed from the right of way at no cost to the County.

8. It is understood and agreed that the rights and privileges herein set out are granted only to the extent of the County's right, title and interest in the land to be entered upon and used by the PERMITTEE, and the PERMITTEE will, at all times, and to the extent permitted by law, assume all risk of and indemnify, defend, and save harmless Columbia County, Florida from any and all loss, damage, cost or expense arising in any manner on account of the exercise or attempted exercise by said PERMITTEE of the aforesaid right and privileges.

9. During construction, all safety regulations of the County shall be observed and the PERMITTEE must take measures, including pacing and the display of safety devices that may be necessary in order to safely conduct the public through the project area in accordance with the Federal Manual on Uniform Traffic Control Devices, as amended for highways.

10. Should the PERMITTEE be desirous of keeping its utilities in place and out of service, the PERMITTEE, by execution of this permit acknowledges its present and continuing ownership of its utilities located between 35.8301139, -090.0063112 and 35.8302742, -090.0064262 within the County's right of way as set forth above. PERMITTEE, as its sole expense, shall promptly remove said out of service utilities whenever Columbia County Public Works Director and/or County Engineer determines said removal is in the public interest.

11. Special instructions: Minimum cover of thirty inches (30") will be required at all locations. Columbia County will not be financially responsible for any damage to facilities with less than thirty inches (30") cover. Cables shall not be located within driveway ditches.

12. Additional Stipulations: _____

It is understood and agreed that commencement by the PERMITTEE is acknowledgment and acceptance of the binding nature of these specialist instructions.

Submitted By: Ryley Rathman
Permittee

Place Corporate Seal



Field Engineer
Signature and Title

Attested



COLUMBIA COUNTY BOARD OF COUNTY COMMISSIONERS AGENDA ITEM REQUEST FORM

The Board of County Commissioners meets the 1st and 3rd Thursday of each month in the Columbia County School Board Administrative Complex Auditorium, 372 West Duval Street, Lake City, Florida 32055. The first meeting of every month is at 9:30AM while the second meeting of every month takes place at 5:30PM. All agenda items are due in the Board's office one week prior to the meeting date.

Today's Date: 2/29/2024 Meeting Date: 3/7/2024

Department: Public Works

1. Nature and purpose of agenda item:

Utility permit from Clearwave Fiber requesting to install a cable along SE Deputy J Davis and CR 252B.

2. Recommended Motion/Action:

Approve

3. Fiscal impact on current budget.

This item has no effect on the current budget.

COLUMBIA COUNTY BOARD OF COUNTY COMISSIONERS UTILITY PERMIT

Date: 02/27/2024 Permit No. _____ County Road SW DEPUTY J DAVIS LN & SW Section No. 34
Permittee Hargray of Florida, LLC dba Clearwave Fiber County Road 252B
Address 8324 Baymeadows Way Suite 102 Jacksonville, FL 32256 Telephone Number 812-430-2143

Requesting permission from Columbia County, Florida, hereinafter called the County, to contract, operate and maintain Proposed directional bore to place (1) and (2) 1.25" HDPE ducts with fiber optic cable and associated appurtenances to provide residential broadband service

FROM: SW County Road 252 B TO: SW Deputy J Davis Ln
Submitted for the Utility Owner by: Korie Nellis, Permit Specialist Korie Nellis 02/27/2024
Typed Name & Title Signature Date

1. Permittee declares that prior to filing this application it has determined the location of all existing utilities, both aerial and underground and the accurate locations are shown on the plans attached hereto and made a part of this application. Proposed work is within corporate limits of Municipality: YES (x) NO (). If YES: LAKE CITY (x) FORT WHITE (). A letter of notification was mailed on _____ to the following utility owners Comcast, AT&T, Teco 02/19/24

2. The Columbia County Public Works Director shall be notified twenty-four (24) hours prior to starting work and again immediately upon completion of work. The Public Works Director is 386-758-1019 located at 607 NW Quinton St, Lake City, FL 32055 Telephone Number _____ The PERMITTEE's employee responsible for Maintenance of Traffic is Hardy Bennett Telephone Number 229-560-6214 (This name may be provided at the time of the 24 hour notice to starting work.)

3. This PERMITTEE shall commence actual construction in good faith within 15 days after issuance of permit, and shall be completed within 60 days after permitted work has begun. If the beginning date is more than 60 days from date of permit approval, then PERMITTEE must review the permit with the Columbia County Public Works Director to make sure no changes have occurred in the transportation facility that would affect the permitted construction.

4. The construction and maintenance of such utility shall not interfere with the property and rights of a prior PERMITTEE.

5. It is expressly stipulated that this permit is a license for permissive use only and that the placing of utilities upon public property pursuant to this permit shall not operate to create or vest any property right in said holder.

6. Pursuant to Section 337-403(1), Florida Statutes, whenever necessary for the construction, repair, improvement, maintenance, safe and efficient operation, alteration or relocation of all, or any portion of said transportation facility as determined by the Columbia County Public Works Director and/or County Engineer, any or all utilities and appurtenances authorized hereunder, shall be immediately removed from said transportation facility or reset or

relocated thereon as required by the Columbia County Public Works Director and/or County Engineer and at the expense of the PERMITTEE.

7. In case of non-compliance with the County's requirements in effect as of the approval date of this permit, this permit void and the facility will have to be brought into compliance or removed from the right of way at no cost to the County.

8. It is understood and agreed that the rights and privileges herein set out are granted only to the extent of the County's right, title and interest in the land to be entered upon and used by the PERMITTEE, and the PERMITTEE will, at all times, and to the extent permitted by law, assume all risk of and indemnify, defend, and save harmless Columbia County, Florida from any and all loss, damage, cost or expense arising in any manner on account of the exercise or attempted exercise by said PERMITTEE of the aforesaid right and privileges.

9. During construction, all safety regulations of the County shall be observed and the PERMITTEE must take measures, including pacing and the display of safety devices that may be necessary in order to safely conduct the public through the project area in accordance with the Federal Manual on Uniform Traffic Control Devices, as amended for highways.

10. Should the PERMITTEE be desirous of keeping its utilities in place and out of service, the PERMITTEE, by execution of this permit acknowledges its present and continuing ownership of its utilities located between _____ and _____ within the County's right of way as set forth above. PERMITTEE, as its sole expense, shall promptly remove said out of service utilities whenever Columbia County Public Works Director and/or County Engineer determines said removal is in the public interest.

11. Special instructions: Minimum cover of thirty inches (30") will be required at all locations. Columbia County will not be financially responsible for any damage to facilities with less than thirty inches (30") cover. Cables shall not be located within driveway ditches.

12. Additional Stipulations: _____

It is understood and agreed that commencement by the PERMITTEE is acknowledgment and acceptance of the binding nature of these specialist instructions.

Submitted By: Korie Nellis
Permittee

Place Corporate Seal

Korie Nellis Permit Manager
Signature and Title

Attested

TYPICAL BURIED CABLE
CONSTRUCTION
PARALLEL

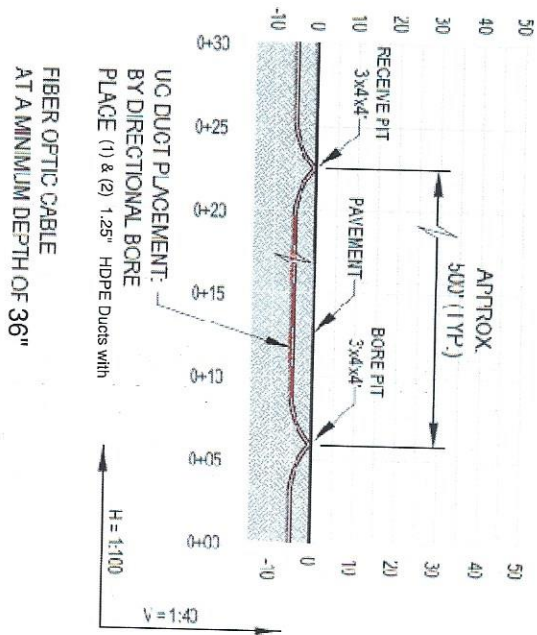

TYPICAL BURIED CABLE
CONSTRUCTION
CROSSING

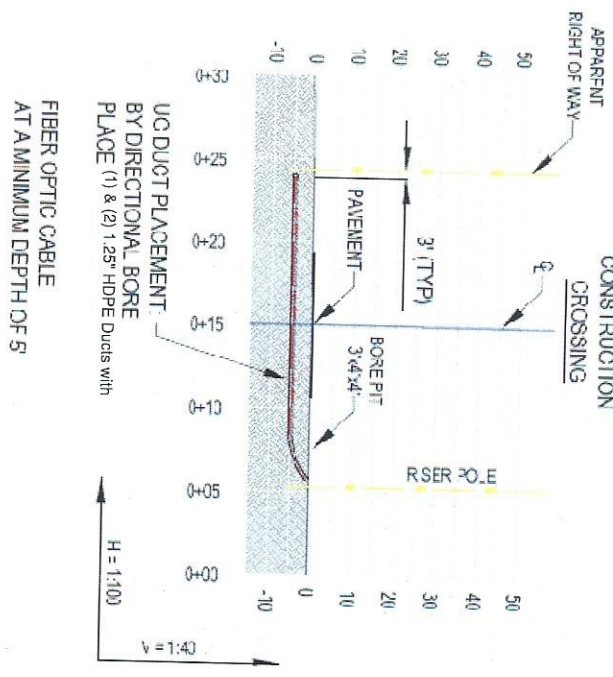

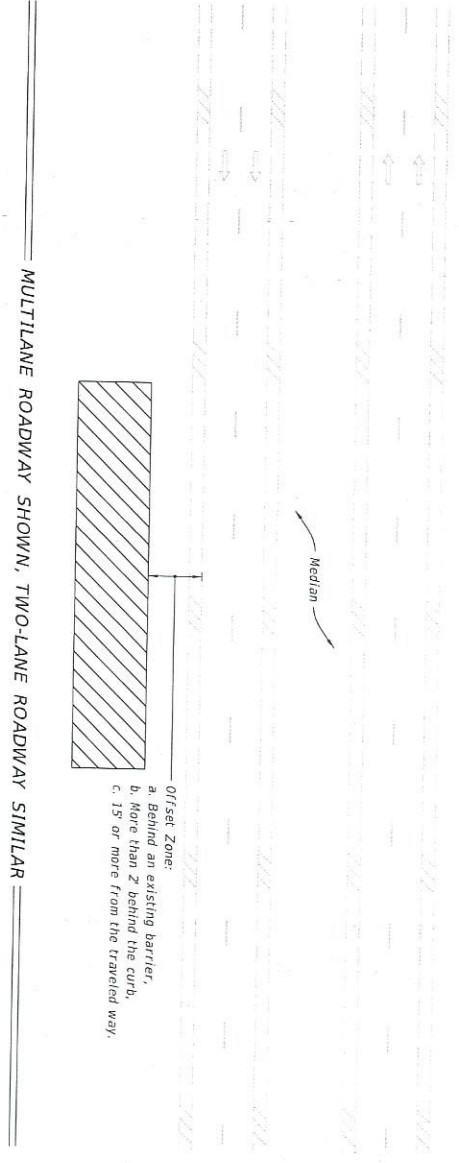

| | | | | | |
|---------------------------|--------------|--|---|------------------|-----------------|
| LAST REVISION 11/01/20 | DESCRIPTION: |  FY 2023-24 STANDARD PLANS | TWO-LANE AND MULTILANE ROADWAY, WORK BEYOND THE SHOULDER | INDEX 102-601 | SHEET 1 OF 1 |
|---------------------------|--------------|--|---|------------------|-----------------|

- NOTES:**
1. This Index applies to Two-Lane, Two-Way and Multilane Roadways, including Medians of divided roadways, with work beyond the shoulder.
 2. Use Index 102-602 when the work operation (excluding establishing and terminating the work area) requires that two or more work vehicles cross the Offset Zone in any one hour period.
 3. Use Index 102-660 when Work Area encroaches a Sidewalk.



- Offset Zone:
- a. Behind an existing barrier,
 - b. More than 2' behind the curb,
 - c. 15' or more from the traveled way.

- SYMBOLS:**
-  Work Area
 -  Lane Identification and Direction of Traffic

- NOTES:**
1. Cover or deactivate pedestrian traffic signal display(s) controlling closed crosswalks.
 2. Place pedestrian LCDs across the full width of the closed sidewalk.
 3. For post mounted signs located near or adjacent to a sidewalk, maintain a minimum 7' clearance from the bottom of the sign panel to the surface of the sidewalk.
 4. "Sidewalk Closed" signs (R9-XX) may be mounted on pedestrian LCDs in accordance with the manufacturer's instructions.
 5. Omit the Advance Closure LCD if it blocks access to other pedestrian facilities (e.g., transit stops, residences, or business entrances).

- SYMBOLS:**
- ▨ Work Area
 - Work Zone Sign
 - Pedestrian Longitudinal Channelizing Device (LCD)
 - ⇄ Lane Identification and Direction of Traffic

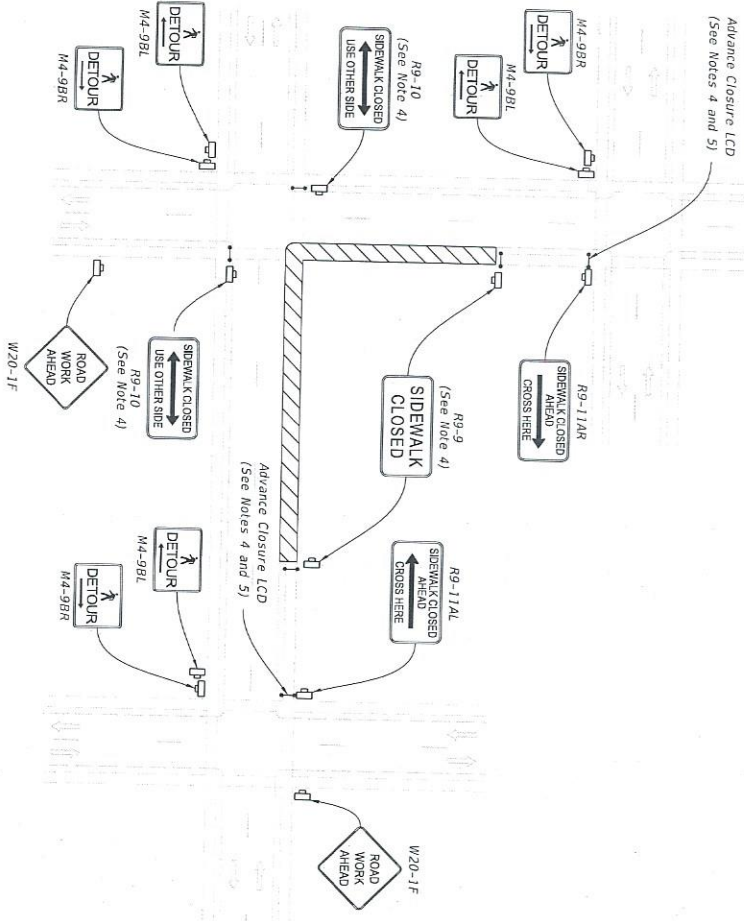

PEDESTRIAN DETOUR

| | | | | |
|---------------------------|--------------|--------------------------------------|------------------|-----------------|
| LAST REVISION 11/01/20 | DESCRIPTION: | FDOT FY 2023-24 STANDARD PLANS | INDEX 102-660 | SHEET 1 of 2 |
|---------------------------|--------------|--------------------------------------|------------------|-----------------|

NOTES:

1. L = Taper Length
B = Buffer Length
X = Work Zone Sign Distance
See Index 102-600 for "L", "B", "X", channelizing device spacing values.
2. Provide a 5' wide temporary pedestrian way with a maximum cross-slope of 0.02, except where space restrictions warrant a minimum width of 4'. Provide a 5' x 5' passing space for temporary pedestrian ways less than 5' in width at intervals not to exceed 200'.
3. When temporary pedestrian ways require curb ramps, meet the requirements of Index 522-002. Detectable warnings are not required for curb ramps diverting pedestrian traffic into a closed lane.
4. The "Speeding Fines Doubled When Workers Present" signs (NOT-13-06) and "End Road Work" signs (G20-2), along with associated work zone sign distances, may be omitted when the work operation will be in place for 24 hours or less.
5. Pedestrian Diversion Option 2 may only be used when called for in the Plans or as approved by an Engineer.

SYMBOLS:

- Work Area
- Temporary Pedestrian Way
- Channelizing Device (See Index 102-600)
- Pedestrian Longitudinal Channelizing Device (LCD)
- Work Zone Sign
- Arrow Board
- Crash Cushion
- Lane Identification and Direction of Traffic

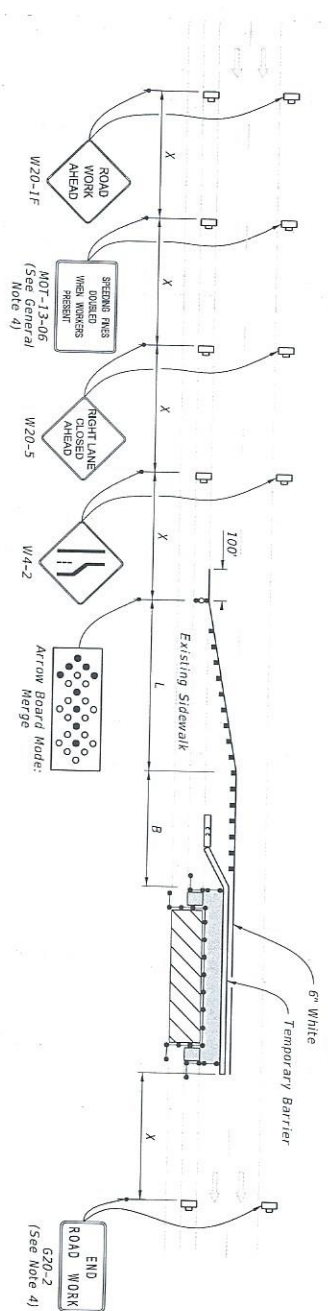

PEDESTRIAN DIVERSION - OPTION 1
(Temporary Barrier Shown, Low Profile Barrier Similar)

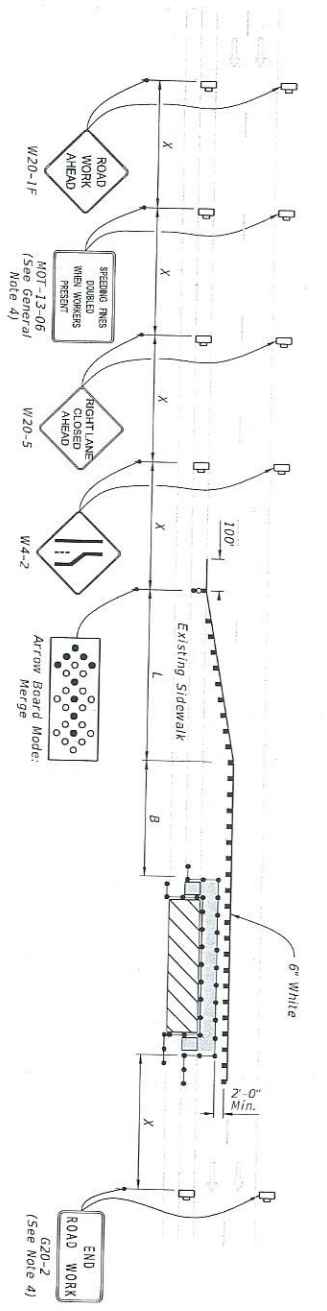

PEDESTRIAN DIVERSION - OPTION 2
(Work Zone Speed 35 mph or Less)

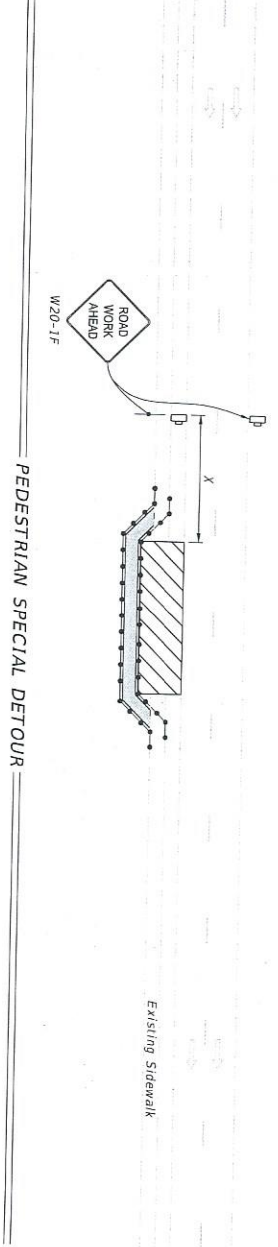

PEDESTRIAN SPECIAL DETOUR

| | |
|---------------|--------------|
| LAST REVISION | DESCRIPTION: |
| 11/01/21 | |

FDOT
FY 2023-24
STANDARD PLANS

SIDEWALK CLOSURE

| | |
|---------|--------|
| INDEX | SHEET |
| 102-660 | 2 OF 2 |

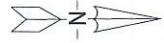

SW DEPUTY J DAVIS LN

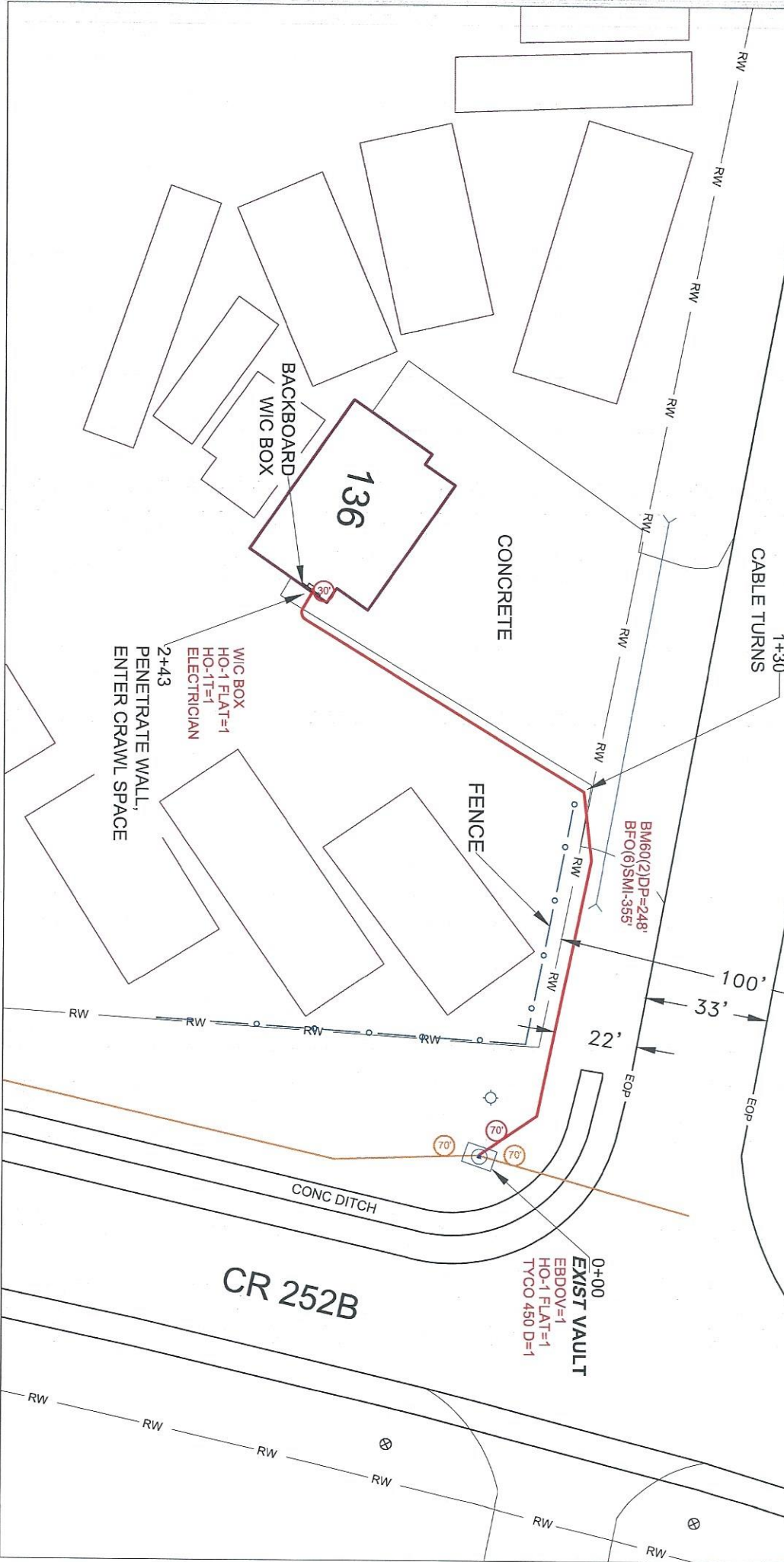

clearwave  **Fiber ENGINEERING**

| | | | | |
|---------------|--------------------------|------------------------|-----------|-------|
| PROJECT: | FAMILY HOME CENTER | PROJECT SITE: P-033825 | BY: | DATE: |
| | 135 SW DEPUTY J DAVIS LN | CONTRACTOR: | STAKED: | |
| | LAKE CITY, FL | SOURCEONE CORP. | RELEASED: | |
| WORK ORDER #: | 2208503407 | SCALE: 1"=30' | AS BUILT: | |
| SHEET # | 2 | | | |

PLACEMENT DETAILS

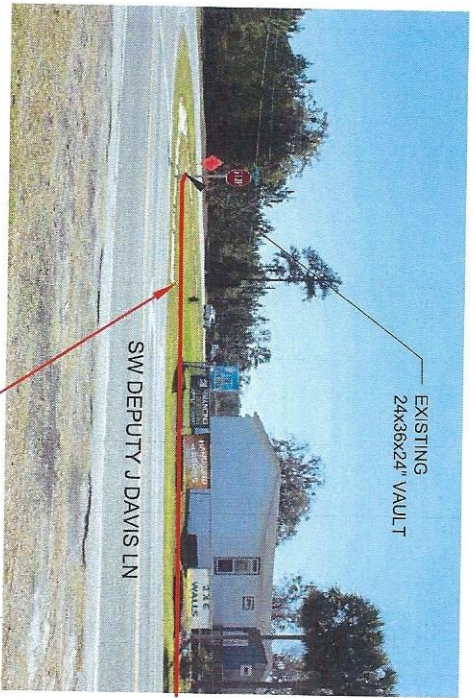

EXISTING
24x36x24" VAULT

SW DEPUTY J DAVIS LN

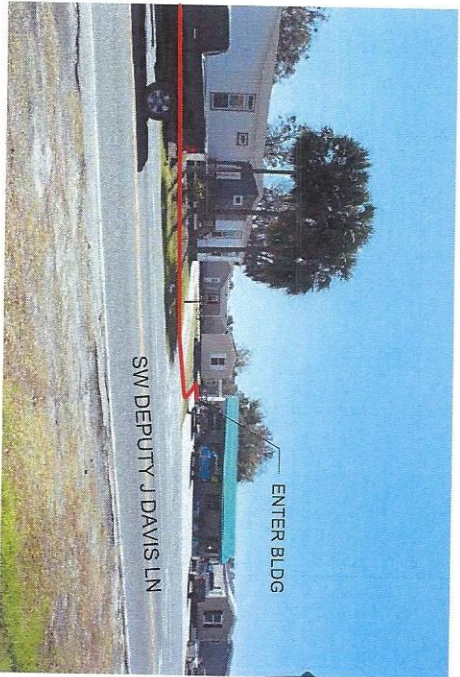

ENTER BLDG

SW DEPUTY J DAVIS LN

PROPOSED 2" HDPE
E/W 6 CT FOC PLACED
BY DIRECTIONAL BORE
MIN DEPTH = 40"

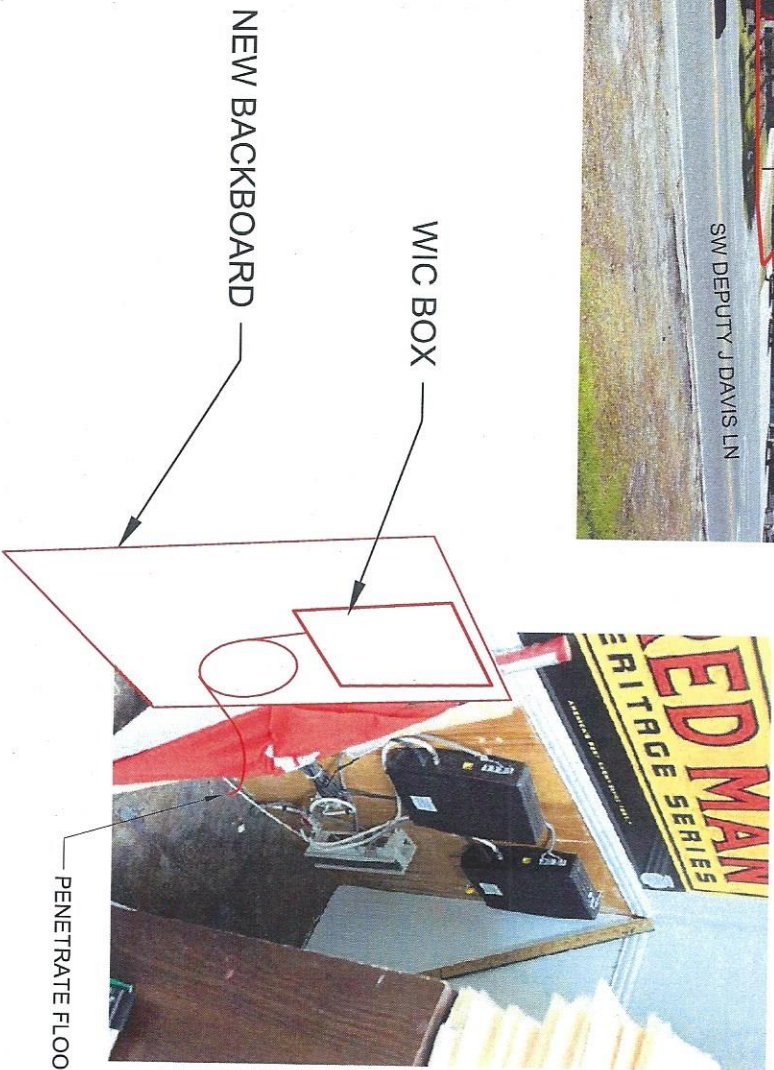

NEW BACKBOARD

WIC BOX

PENETRATE FLOOR

| | |
|---|--------------------------|
| clearwave  Fiber ENGINEERING | |
| PROJECT: | FAMILY HOME CENTER |
| CONTRACTOR: | 138 SW DEPUTY J DAVIS LN |
| SCALE: | LAKE CITY, FL |
| WORK ORDER #: | 2208503407 |
| PROJECT SITE: P-033625 | BY DATE |
| CONTRACTOR: SOURCEONE CORP. | STAKED: - |
| SCALE: NTS | RELEASED: - |
| | AS BUILT: - |
| | SHEET # 3 |



**COLUMBIA COUNTY BOARD OF COUNTY COMMISSIONERS
AGENDA ITEM REQUEST FORM**

The Board of County Commissioners meets the 1st and 3rd Thursday of each month in the Columbia County School Board Administrative Complex Auditorium, 372 West Duval Street, Lake City, Florida 32055. The first meeting of every month is at 9:30AM while the second meeting of every month takes place at 5:30PM. All agenda items are due in the Board's office one week prior to the meeting date.

Today's Date: 2/28/2024 Meeting Date: 3/7/2024

Department: Zoning Department

1. Nature and purpose of agenda item:

Special Family Lot Permit by Wilma Bringer for daughter Ashely Jones

2. Recommended Motion/Action:

Approve SFLP 24 0202

3. Fiscal impact on current budget.

This item has no effect on the current budget.



Columbia County Gateway to Florida

| | |
|-------------------------|-----------|
| FOR PLANNING USE ONLY | |
| Application # SFLP | 240202 |
| Application Fee \$50.00 | |
| Receipt No. | 766337 |
| Filing Date | 2-22-2024 |
| Completeness Date | |

Special Family Lot Permit Application

A. PROJECT INFORMATION

- Title Holder's Name: Wilma Bringer
- Address of Subject Property: 9764 SW Tustenuggee Ave, Lake City
- Parcel ID Number(s): 06-65-17-09613-001
- Future Land Use Map Designation: AG
- Zoning Designation: A-3
- Acreage of Parent Parcel: 21.21 AC
- Acreage of Property to be Deeded to Immediate Family Member: Ashley Jones 3.38 AC
- Existing Use of Property: RES
- Proposed use of Property: RES
- Name of Immediate Family Member for which Special Family Lot is to be Granted: ASHLEY JONES - DAUGHTER

PLEASE NOTE: Immediate family member must be a parent, grandparent, adopted parent, stepparent, sibling, child, adopted child, stepchild, or grandchild of the person who is conveying the parcel to said individual.

B. APPLICANT INFORMATION

- Applicant Status Owner (title holder) Agent
- Name of Applicant(s): Wilma Bringer Title: _____
 Company name (if applicable): _____
 Mailing Address: 9764 SW Tustenuggee Ave.
 City: Lake City State: FL Zip: 32024
 Telephone: (886) 98446320 Fax: (____) _____ Email: Ashleyjones@gmail.com

PLEASE NOTE: Florida has a very broad public records law. Most written communications to or from government officials regarding government business is subject to public records requests. Your e-mail address and communications may be subject to public disclosure.

- If the applicant is agent for the property owner*.
 Property Owner Name (title holder): _____
 Mailing Address: _____
 City: _____ State: _____ Zip: _____
 Telephone: (____) _____ Fax: (____) _____ Email: _____

PLEASE NOTE: Florida has a very broad public records law. Most written communications to or from government officials regarding government business is subject to public records requests. Your e-mail address and communications may be subject to public disclosure.

*Must provide an executed Property Owner Affidavit Form authorizing the agent to act on behalf of the property owner.

FAMILY RELATIONSHIP AFFIDAVIT

STATE OF FLORIDA
COUNTY OF COLUMBIA

Inst: 202412003630 Date: 02/22/2024 Time: 12:03PM
Page 1 of 2 B: 1508 P: 1907, James M Swisher Jr, Clerk of Court
Columbia, County, By: VC me
Deputy Clerk

BEFORE ME the undersigned Notary Public personally appeared, Wilma
Bringer, the Owner of the parent parcel which has been subdivided for
Ashtley Jones, the Immediate Family Member of the Owner, and which is
intended for the Immediate Family Members primary residence use. The Immediate Family
Member is related to the Owner as daughter. Both individuals being
first duly sworn according to law, depose and say:

1. Affiant acknowledges Immediate Family Member is defined as parent, grandparent, step-parent, adopted parent, sibling, child, step-child, adopted child or grandchild.
2. Both the Owner and the Immediate Family Member have personal knowledge of all matters set forth in this Affidavit.
3. The Owner holds fee simple title to certain real property situated in Columbia County, and more particularly described by reference with the Columbia County Property Appraiser Parent Tract Tax Parcel No. 06-65-17-09613-001
4. The Immediate Family Member holds fee simple title to certain real property divided from the Owners' parent parcel situated in Columbia County and more particularly described by reference to the Columbia County Property Appraiser Tax Parcel No. _____
5. No person or entity other than the Owner and Immediate Family Member to whom permit is being issued, including persons residing with the family member claims or is presently entitled to the right of possession or is in possession of the property, and there are no tenancies, leases or other occupancies that affect the property.
6. This Affidavit is made for the specific purpose of inducing Columbia County to recognize a family division for an Immediate Family Member being in compliance with the density requirements of the Columbia County's Comprehensive Plan and Land Development Regulations (LDR's).
7. This Affidavit and Agreement is made and given by Affiants with full knowledge that the facts contained herein are accurate and complete, and with full knowledge that the penalties under Florida law for perjury include conviction of a felony of the third degree.

We Hereby Certify that the facts represented by us in this Affidavit are true and correct and we accept the terms of the Agreement and agree to comply with it.

Wilma Bringer
Owner

Ashley Jones
Immediate Family Member

Wilma Bringer
Typed or Printed Name

Ashley Jones
Typed or Printed Name

Subscribed and sworn to (or affirmed) before me this 22 day of Feb, 2024
by Wilma Bringer (Owner) who is personally known to me or has produced
FL DL as identification.

Emaleigh Williams
Notary Public

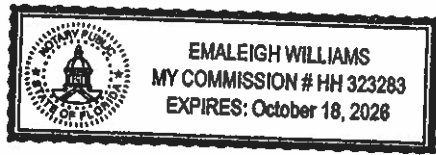

Subscribed and sworn to (or affirmed) before me this 22 day of Feb, 2024
by Ashley Jones (Family Member) who is personally known to me or has
produced FL DL as identification.

Emaleigh Williams
Notary Public



APPROVED:
COLUMBIA COUNTY, FLORIDA

By: _____

Name: _____

Title: _____

Columbia County, FLA - Building & Zoning Property Map

Printed: Wed Feb 28 2024 11:58:11 GMT-0500 (Eastern Standard Time)

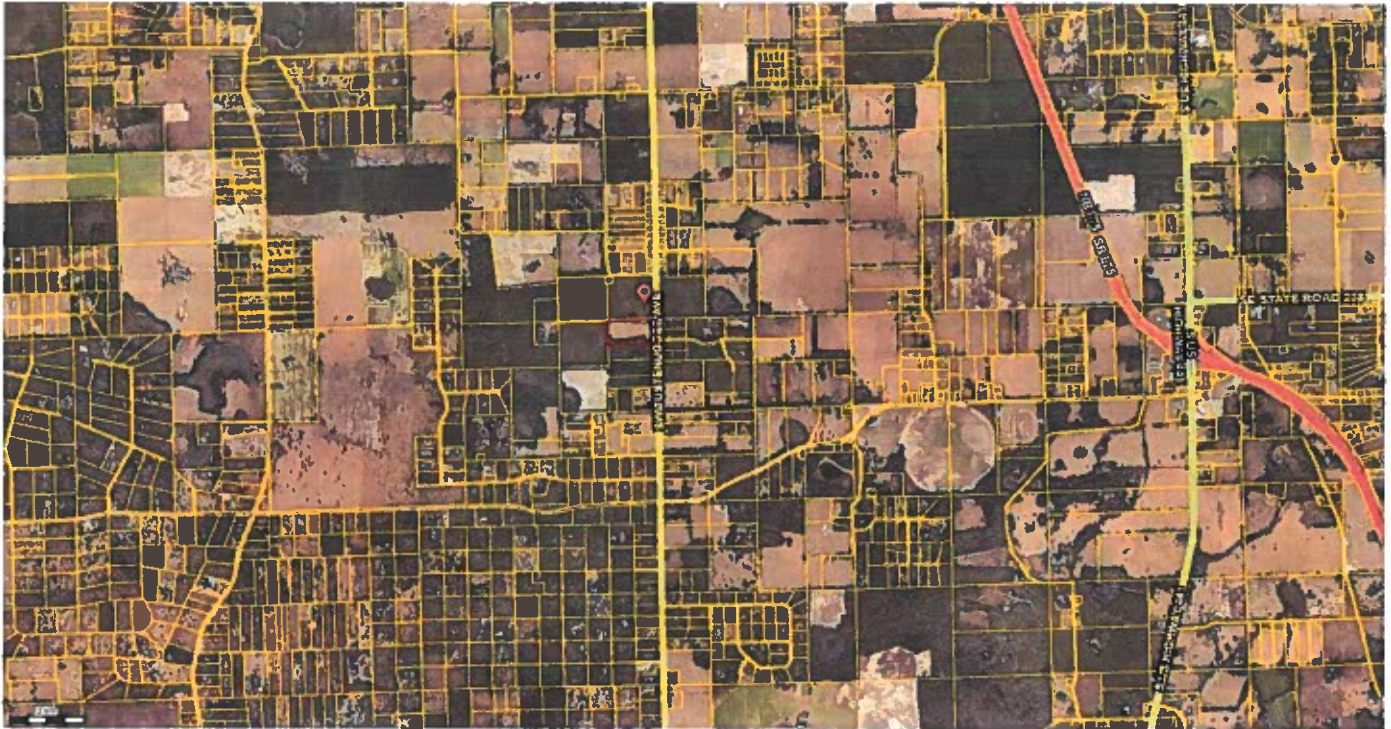

Parcel No: 06-6S-17-09613-001
Owner: BRINGGER RICHARD D, BRINGGER WILMA J
Subdivision:
Lot:
Acres: 20.6345749
Deed Acres: 21.21 Ac
District: District 5 Tim Murphy
Future Land Uses: Agriculture - 3
Flood Zones: A,
Official Zoning Atlas: A-3

All data, information, and maps are provided "as is" without warranty or any representation of accuracy, timeliness of completeness. Columbia County, FL makes no warranties, express or implied, as to the use of the information obtained here. There are no implied warranties of merchantability or fitness for a particular purpose. The requester acknowledges and accepts all limitations, including the fact that the data, information, and maps are dynamic and in a constant state of maintenance, and update.



**COLUMBIA COUNTY BOARD OF COUNTY COMMISSIONERS
AGENDA ITEM REQUEST FORM**

The Board of County Commissioners meets the 1st and 3rd Thursday of each month in the Columbia County School Board Administrative Complex Auditorium, 372 West Duval Street, Lake City, Florida 32055. The first meeting of every month is at 9:30AM while the second meeting of every month takes place at 5:30PM. All agenda items are due in the Board's office one week prior to the meeting date.

Today's Date: 2/28/2024 Meeting Date: 3/7/2024

Department: Zoning Department

1. Nature and purpose of agenda item:

Consideration special family lot permit by Timothy and Constance Jones for daughter Stephanie

2. Recommended Motion/Action:

Approve SFLP 24 0203

3. Fiscal impact on current budget.

This item has no effect on the current budget.



Columbia County Gateway to Florida

| | |
|-----------------------|------------------|
| FOR PLANNING USE ONLY | |
| Application # SFLP | <u>240203</u> |
| Application Fee | \$50.00 |
| Receipt No. | |
| Filing Date | <u>2-26-2024</u> |
| Completeness Date | |

Special Family Lot Permit Application

A. PROJECT INFORMATION

- Title Holder's Name: Timothy A. Jones Constance V. Jones
- Address of Subject Property: 1430 SE Weeks Ln, Lake City, FL 32025
- Parcel ID Number(s): 19-45-18-10387-003 (38377)
- Future Land Use Map Designation: AGRICULTURE
- Zoning Designation: A3
- Acreage of Parent Parcel: 20 acres
- Acreage of Property to be Deeded to Immediate Family Member: 5.01 acres
- Existing Use of Property: RES.
- Proposed use of Property: RES.
- Name of Immediate Family Member for which Special Family Lot is to be Granted: Stephanie Jones

PLEASE NOTE: Immediate family member must be a parent, grandparent, adopted parent, stepparent, sibling, child, adopted child, stepchild, or grandchild of the person who is conveying the parcel to said individual.

B. APPLICANT INFORMATION

- Applicant Status Owner (title holder) Agent
- Name of Applicant(s): Timothy A Jones Title: owner
 Company name (if applicable): Constance V. Jones owner
 Mailing Address: 1430 SE Weeks Ln
 City: Lake City State: FL Zip: 32025
 Telephone: (386) 303-1157 Fax: () Email: cvjones58@gmail.com

PLEASE NOTE: Florida has a very broad public records law. Most written communications to or from government officials regarding government business is subject to public records requests. Your e-mail address and communications may be subject to public disclosure.

- If the applicant is agent for the property owner*.
 Property Owner Name (title holder): _____
 Mailing Address: _____
 City: _____ State: _____ Zip: _____
 Telephone: () Fax: () Email: _____

PLEASE NOTE: Florida has a very broad public records law. Most written communications to or from government officials regarding government business is subject to public records requests. Your e-mail address and communications may be subject to public disclosure.

*Must provide an executed Property Owner Affidavit Form authorizing the agent to act on behalf of the property owner.

FAMILY RELATIONSHIP AFFIDAVIT

STATE OF FLORIDA
COUNTY OF COLUMBIA

BEFORE ME the undersigned Notary Public personally appeared, Timothy A. Jones & Constance V. Jones the Owner of the parent parcel which has been subdivided for Stephanie Jones, the Immediate Family Member of the Owner, and which is intended for the Immediate Family Members primary residence use. The Immediate Family Member is related to the Owner as our child. Both individuals being first duly sworn according to law, depose and say:

1. Affiant acknowledges Immediate Family Member is defined as parent, grandparent, step-parent, adopted parent, sibling, child, step-child, adopted child or grandchild.
2. Both the Owner and the Immediate Family Member have personal knowledge of all matters set forth in this Affidavit.
3. The Owner holds fee simple title to certain real property situated in Columbia County, and more particularly described by reference with the Columbia County Property Appraiser Parent Tract Tax Parcel No. 19-45-18-10387-003 (38377)
4. The Immediate Family Member holds fee simple title to certain real property divided from the Owners' parent parcel situated in Columbia County and more particularly described by reference to the Columbia County Property Appraiser Tax Parcel No. _____.
5. No person or entity other than the Owner and Immediate Family Member to whom permit is being issued, including persons residing with the family member claims or is presently entitled to the right of possession or is in possession of the property, and there are no tenancies, leases or other occupancies that affect the property.
6. This Affidavit is made for the specific purpose of inducing Columbia County to recognize a family division for an Immediate Family Member being in compliance with the density requirements of the Columbia County's Comprehensive Plan and Land Development Regulations (LDR's).
7. This Affidavit and Agreement is made and given by Affiants with full knowledge that the facts contained herein are accurate and complete, and with full knowledge that the penalties under Florida law for perjury include conviction of a felony of the third degree.

We Hereby Certify that the facts represented by us in this Affidavit are true and correct and we accept the terms of the Agreement and agree to comply with it.

Constance V. Jones
[Signature]
Owner
Constance V. Jones
Timothy A. Jones
Typed or Printed Name

X [Signature]
Immediate Family Member
Stephanie Jones
Typed or Printed Name

Subscribed and sworn to (or affirmed) before me this 26 day of Feb, 2024
by Constance V. Jones (Owner) who is personally known to me or has produced
Known Timothy Jones as identification.

[Signature]
Notary Public

Subscribed and sworn to ^{DS} (or affirmed) before me this 26 day of Feb, 2024
by Stephanie Jones (Family Member) who is personally known to me or has
produced known as identification.
Stephanie Jones.

[Signature]
Notary Public

APPROVED:
COLUMBIA COUNTY, FLORIDA

By: _____

Name: _____

Title: _____



Columbia County, FLA - Building & Zoning Property Map

Printed: Wed Feb 28 2024 11:40:11 GMT-0500 (Eastern Standard Time)



Parcel No: 19-4S-18-10387-003
Owner: JONES TIMOTHY A, JONES CONSTANCE V
Subdivision:
Lot:
Acres: 20.3236923
Deed Acres: 20 Ac
District: District 4 Everett Phillips
Future Land Uses: Agriculture - 3
Flood Zones: A,
Official Zoning Atlas: A-3