

COLUMBIA COUNTY BOARD OF COUNTY COMMISSIONERS

**POST OFFICE BOX 1529
LAKE CITY, FLORIDA 32056 - 1529**

CONSENT AGENDA

March 21, 2019

5:30 P.M.

-
- (1) BCC Administration - Minutes - Board of County Commissioners - Special Meeting/Workshop - February 21, 2019 (pg. 1)**
 - (2) BCC Administration - Minutes - Board of County Commissioners - Regular Meeting - February 21, 2019 (pg. 5)**
 - (3) BCC Administration - Minutes - Board of County Commissioners - Regular Meeting - March 7, 2019 (pg. 12)**
 - (4) BCC Administration - Another Way, Inc. - Certification of Local Government Approval - Emergency Shelter Only (pg. 17)**
 - (5) BCC Administration - Letter of Support Request - Palms Medical Group (pg. 21)**
 - (6) BCC Administration - Termite Policy for Courthouse - \$535 (pg. 23)**
 - (7) Building and Zoning - Special Family Lot Permit 19-09 - from Robert & Janice Cox to Catherine Todd, daughter - 303 SE Rodney Dicks Drive, Lake City, FL (pg. 26)**
 - (8) Clerk to Board Finance - Approval of Bills and Vouchers Submitted March 6, 2019 - \$1,302,852 (pg. 43)**
 - (9) Emergency Management - BA 19-39 - HMGP Tropical Storm Debby Projects and Hurricane Irma Application - \$8,399 (pg. 49)**
 - (10) Emergency Management - Modification No. Z0618 Subgrant Agreement - Hurricane Irma Reimbursement (pg. 51)**
 - (11) Fire Department - Purchase Asset Tracking and Inventory Management Software - \$3,120 (pg. 55)**
 - (12) Library - BA 19-40 - Friends of the Library Donation - \$2,554 (pg. 58)**
 - (13) Public Works - FDOT Lighting Contract - \$131,636 (pg. 62)**
 - (14) Public Works - Utility Permit - FPL - NW Jimmy Way, Sunnyboork Road, NE Audie Terrance, NW Quinten Street, and NW Josephine Street (pg. 68)**
 - (15) Public Works - Utility Permit - Comcast - Yates Loop (pg. 81)**

- (16) Public Works - Utility Permit - Windstream - NW Stephen Foster Drive (pg. 89)**
- (17) Purchasing - Asset Disposal (pg. 101)**
- (18) Tourist Development - Sports Marketing/Advertising Agreement - Sports Events Magazine - \$4,996 (pg. 111)**



**COLUMBIA COUNTY BOARD OF COUNTY COMMISSIONERS
AGENDA ITEM REQUEST FORM**

The Board of County Commissioners meets the 1st and 3rd Thursday of each month at 5:30 p.m. in the Columbia County School Board Administrative Complex Auditorium, 372 West Duval Street, Lake City, Florida 32055. All agenda items are due in the Board's office one week prior to the meeting date.

Today's Date: 3/5/2019 Meeting Date: 3/21/2019

Name: Penny Stanley Department: BCC Administration

Division Manager's Signature:

1. Nature and purpose of agenda item:

BCC Administration - Minutes - Board of County Commissioners - Special Meeting/Workshop - February 21, 2019

2. Recommended Motion/Action:

Requesting Approval

3. Fiscal impact on current budget.

This item has no effect on the current budget.

Columbia County
Board of County Commissioners

Minutes of
Special Meeting/Workshop Agenda
February 21, 2019

The Columbia County Board of County Commissioners met in a Workshop Agenda/Special meeting at the auditorium of the School Board Administrative Complex at 9:00 a.m. The meeting opened with prayer and the Pledge of Allegiance to the Flag of the United States of America.

Commissioners in Attendance: Chairman Ronald Williams, Rocky Ford,
Bucky Nash, Timothy Murphy and Toby Witt

Others in Attendance: County Manager Ben Scott ("CM")
Assistant County Manager David Kraus ("ACM")
Assistant County Manager Kevin Kirby ("ACM")
County Attorney Joel Foreman
Deputy Clerk Susan Weeks

Workshop:

Emergency Medical Services Review

Fire Chief Jeff Crawford presented to the board a review on the Emergency Medical Services for the county. Presentation is attached to the original minutes.

Discussion ensued.

Citizen Stewart Lilker offered comment.

Rick Naegler, CEO Lake City Medical Center, offered comment.

2019 – 2020 Budget Workshop Issues

The Board has requested CM Scott reduce the Millage rate this fiscal year and again the next fiscal year.

Discussion ensued.

CM Scott will present information to the board for review at the May 16th and June 20th meetings for the 2019-2020 budget.

Special Meeting Discussion Items:

911 Backup Location

The 911 Committee recommended the backup site be at either the City of Lake City or the new jail.

Discussion ensued.

911 Director Brazil and Sheriff Hunter addressed the Board.

Fire Chief Crawford offered comment.

MOTION by Commissioner Nash to give Ben permission to talk to the City Manager and get a Interlocal if they are willing to make the changes to the wall and provide the security that we need for the backup 911 and to move forward with putting at the City. SECOND by Commissioner Murphy.

Citizen Stewart Lilker offered support.

Discussion ensued.

The Chairman called for the vote. The motion carried unanimously.

US Highway 90 Emergency Response Protocol

911 Committee recommended giving the Lake City Police Department sidewalk to sidewalk jurisdiction on the Highway 90 corridor to help elevate confusion of whether it is on City or County property.

911 Director Brazil and Sheriff Hunter addressed the Board.

MOTION by Commissioner Nash to give the City of Lake City authority to dispatch within City limits sidewalk to sidewalk. SECOND by Commissioner Murphy. The motion carried unanimously.

Jail Financing

CM Scott presented the Board with financing options for the new jail. Those options are attached to the original minutes.

Jim Gollahon, with Gollahon Financial Services, answered questions and concerns.

Discussion ensued.

MOTION by Commissioner Nash to do the 15 year option for 17 million dollars. SECOND by Commissioner Murphy.

Citizen Stewart Lilker offered comment and asked questions.

The Chairman called for the vote. The motion carried unanimously.

Sheriff Hunter addressed the Board.

MOTION by Commissioner Witt that we leave the 39%, contingent on this money staying with us to fund the jail. Motion failed for a lack of a second.

MOTION by Commissioner Murphy that we rescind the 39% agreement and go back to the standard way that other counties in Florida do it. SECOND by Commissioner Nash.

County Attorney Foreman recommended this issue be noticed on another meeting agenda.

Citizen Stewart Lilker offered comment.

The Board directed staff to put this issue on the next meeting agenda.

The Chairman called for the vote. The motion carried unanimously.

Adjournment

There being no further business, the meeting adjourned at 3:20 p.m.

ATTEST:

Ronald Williams, Chairman
Board of County Commissioners

P. DeWitt Cason
Clerk of Circuit Court



**COLUMBIA COUNTY BOARD OF COUNTY COMMISSIONERS
AGENDA ITEM REQUEST FORM**

The Board of County Commissioners meets the 1st and 3rd Thursday of each month at 5:30 p.m. in the Columbia County School Board Administrative Complex Auditorium, 372 West Duval Street, Lake City, Florida 32055. All agenda items are due in the Board's office one week prior to the meeting date.

Today's Date: 3/1/2019 Meeting Date: 3/21/2019

Name: Penny Stanley Department: BCC Administration

Division Manager's Signature: 

1. Nature and purpose of agenda item:

BCC Administration - Minutes - Board of County Commissioners - Regular Meeting - February 21, 2019

2. Recommended Motion/Action:

Requesting Approval

3. Fiscal impact on current budget.

This item has no effect on the current budget.

Columbia County
Board of County Commissioners

Minutes of
February 21, 2019

The Columbia County Board of County Commissioners met in a regular meeting at the auditorium of the School Board Administrative Complex at 5:30 p.m. The meeting opened with prayer and the Pledge of Allegiance to the Flag of the United States of America.

Commissioners in Attendance: Chairman Ronald Williams, Rocky Ford,
Bucky Nash, Toby Witt and Timothy Murphy

Others in Attendance: County Manager Ben Scott ("CM")
Assistant County Manager David Kraus ("ACM")
Assistant County Manager Kevin Kirby ("ACM")
County Attorney Joel Foreman
Deputy Clerk Susan Weeks

Agenda Additions/Deletions

Additions:
Special family lot permit application.

Deletions:
None

MOTION by Commissioner Murphy to approve the agenda as amended.
SECOND by Commissioner Witt. The motion carried unanimously.

Ministerial Matters

Representative Chuck Brannon Open House

Dan Hartley with Mr. Brannon's office gave the Board an update on the items that Mr. Brannon is involved with and invited everyone to an open house for the local office, February 26, 2019 at 4:45 p.m.

Florida Association of Counties ("FAC")

Ken Moneghan with FAC, addressed the Board and presented the Board with a plaque in recognition of their support.

Ginger Delagal, Executive Director of FAC, addressed the Board.

Building and Zoning Public Hearings:

Land Development Regulations (“LDR”) Amendments

1. CPA 0229-To amend the text of the Future Land Use Plan Map of the Comprehensive Plan by amending the classification from Residential, Low Density to Residential, Moderate Density for tax parcel 05521-000. [Ordinance No. 2019-01]

The public hearing opened and closed without comment.

MOTION by Commissioner Nash to approve Ordinance No. 2019-01. SECOND by Commissioner Murphy. The motion carried unanimously.

2. Z 0579 – To amend the Official Zoning Atlas by amending the zoning from Residential Single Family/Mobile Home-2 to Residential Single Family/Mobile Home-3 for tax parcel 05521-000. [Ordinance No. 2019-02]

The public hearing opened and closed without comment.

MOTION by Commissioner Murphy to approve Ordinance No. 2019-02. SECOND by Commissioner Witt. The motion carried unanimously.

3. CPA 0230-To amend the text of the Future Land Use Plan Map of the Comprehensive Plan by amending the classification from Residential, Low Density to Industrial for tax parcel 08410-000 & 08410-002-002. [Ordinance No. 2019-03]

The public hearing opened and closed without comment.

MOTION by Commissioner Witt to approve Ordinance No. 2019-03. SECOND by Commissioner Murphy. The motion carried unanimously.

4. Z 0580 – To amend the Official Zoning Atlas by amending the zoning from Residential Single Family -2 to Industrial, Light and Warehousing for tax parcel 08410-000 & 08410-002. [Ordinance No. 2019-04]

The public hearing opened and closed without comment.

MOTION by Commissioner Witt to approve Ordinance No. 2019-04. SECOND by Commissioner Murphy. The motion carried unanimously.

Consent Agenda:

MOTION by Commissioner Nash to approve the consent agenda. SECOND by Commissioner Murphy. The motion carried unanimously.

- (1) BCC Administration - Minutes - Board of County Commissioners – Regular Meeting - May 3, 2018
- (2) BCC Administration - Minutes - Board of County Commissioners – Final Budget/Regular Meeting - September 20, 2018
- (3) BCC Administration - Minutes - Board of County Commissioners – Regular Meeting - January 17, 2019
- (4) BCC Administration - Minutes - Board of County Commissioners – Regular Meeting - February 7, 2019
- (5) BCC Administration - Amendment to Interlocal Agreement - City of Lake City - Bell Road Corridor Utilities
- (6) BCC Administration - Suwannee River Economic Council - Continuation of Existing Representative - Bucky Nash
- (7) Building and Zoning - Special Family Lot Permit (SFLP) 1905 - George Ollrich, Father - Robert Oellrich, Property Owner - 173 NW Benford Glen
- (8) Clerk to Board Finance - Approval of Bills and Vouchers - \$1,192
- (9) Clerk to Board Finance - Approval of Bills and Vouchers - \$38,270
- (10) Clerk to Board Finance - Approval of Bills and Vouchers - \$885,854
- (11) Library - Closing for Easter - April 20, 21, 2019
- (12) Library - BA 19-32 - Library Donations - \$150
- (13) Public Works - Utility Permit - AT&T - High Falls Road
- (14) Public Works - Utility Permit - AT&T - Howell Road
- (15) Public Works - Utility Permit - Comcast - Country Club Road
- (16) Public Works - Utility Permit - Comcast - Fieldstone Court
- (17) Public Works - Utility Permit - Comcast - Green Acres Way
- (18) Solid Waste - BA 19-34 - FDACS-DOH - Mosquito Control Additional Funding - \$12,000
- (19) Tourist Development - Official Florida Transportation Map - Full Panel Advertisement - \$9,000

MOTION by Commissioner Witt to adopt the consent agenda. SECOND by Commissioner Nash. The motion carried unanimously.

Discussion and Action Items:

BA 19-33 - Traffic Signal/Light Maintenance

An amendment to fund traffic/signal light maintenance for remaining fiscal year in the amount of \$75,000.

MOTION by Commissioner Witt to approve BA 19-33. SECOND by Commissioner Nash.

Discussion ensued.

The Chairman called for the vote. The motion carried unanimously.

Madden Media Services Agreement

Staff recommended approval of Madden Media Services Agreement- New Sports Website \$24,600

MOTION by Commissioner Witt to approve of Madden Media Contact in the amount of \$24,600. SECOND by Commissioner Murphy. The motion carried unanimously.

Ichetucknee Partnership

Staff recommended approval of the annual Contract for Services between Columbia County and The Ichetucknee Partnership in the amount of \$40,000.

Discussion ensued.

MOTION by Commissioner Nash to approve contract. SECOND by Commissioner Ford. The motion carried unanimously.

Weed and Insect Control

Staff recommended approval of the contract with Southeastern Turf Grass Supply, Inc. in the amount of \$44,979 for weed and insect control.

MOTION by Commissioner Murphy to approve contract. SECOND by Commissioner Nash. The motion carried unanimously.

Welcome Center Renovation

Staff recommended approval of Welcome Center Renovation Change Order in the amount of \$40,407.

MOTION by Commissioner Murphy to accept change order in the amount of \$40,407. SECOND by Commissioner Ford. The motion carried unanimously.

Solid Waste Collection

Staff recommended approval of the revised Solid Waste Collection Franchise Application with a change from \$500 to \$50 due to a typo.

Commissioner Ford recused himself from this item.

Discussion ensued.

MOTION by Commissioner Witt to approve the revised franchise application. SECOND by Commissioner Nash. The motion carried by a vote of 4 to 0 with Commissioner Ford abstaining.

Staff recommended approval of Solid Waste Collection Franchise Application for Sheppard's Container Service, LLC.

Commissioner Ford recused himself from this item.

Discussion ensued.

Robert Sheppard offered comment

MOTION by Commissioner Murphy to accept the application from Sheppard's Container Service. SECOND by Commissioner Nash.

Discussion ensued.

The Chairman called for the vote. The motion carried by a vote of 4 to 0 with Commissioner Ford abstaining.

Building and Zoning – Special Family Lot Permit (“SFLP”) 1906

Staff recommended approval of SFLP 1906 – Kayla Hebert, Granddaughter - H. Michael Thomas, Property Owner – 15838 N US HWY 441.

MOTION by Commissioner Murphy to accept SFLP 1906. SECOND by Commissioner Ford. The motion carried unanimously.

Open Public Comments and/or Questions:

Members of the public addressed the Board with their comments and/or questions regarding the following items:

Sandra Smith made suggestions on panhandlers.

Jeffrey Hill on the County Attorney and ditches being dug on his wife's land.

Adjournment

There being no further business, the meeting adjourned at 6:35 p.m.

ATTEST:

Ronald Williams, Chairman
Board of County Commissioners

P. DeWitt Cason
Clerk of Circuit Court



**COLUMBIA COUNTY BOARD OF COUNTY COMMISSIONERS
AGENDA ITEM REQUEST FORM**

The Board of County Commissioners meets the 1st and 3rd Thursday of each month at 5:30 p.m. in the Columbia County School Board Administrative Complex Auditorium, 372 West Duval Street, Lake City, Florida 32055. All agenda items are due in the Board's office one week prior to the meeting date.

Today's Date: 3/8/2019 Meeting Date: 3/21/2019

Name: Penny Stanley Department: BCC Administration

Division Manager's Signature:

1. Nature and purpose of agenda item:

BCC Administration - Minutes - Board of County Commissioners - Regular Meeting - March 7, 2019

2. Recommended Motion/Action:

Requesting Approval

3. Fiscal impact on current budget.

This item has no effect on the current budget.

Columbia County
Board of County Commissioners

Minutes of
March 07, 2019

The Columbia County Board of County Commissioners met in a regular meeting at the auditorium of the School Board Administrative Complex at 5:30 p.m. The meeting opened with prayer and the Pledge of Allegiance to the Flag of the United States of America.

Commissioners in Attendance: Chairman Ronald Williams, Rocky Ford,
Timothy Murphy, Bucky Nash and Toby Witt.

Others in Attendance: County Manager Ben Scott ("CM")
Assistant County Manager David Kraus ("ACM")
Assistant County Manager Kevin Kirby ("ACM")
County Attorney Joel Foreman
Deputy Clerk Katrina Vercher

Agenda Additions/Deletions

There were no additions or deletions.

MOTION by Commissioner Murphy to approve the agenda as presented.
SECOND by Commissioner Witt. The motion carried unanimously.

Ministerial Matters

Proclamation No. 2019P-5

A proclamation recognizing Public Safety Telecommunicator Training Quality Assurance Coordinator Jason Rosenfield and Public Safety Telecommunicator Trainee Travis Czaban for their display of the highest level of professionalism during a stressful situation.

MOTION by Commissioner Nash to approve Proclamation No. 2019P-5.
SECOND by Commissioner Murphy. The motion carried unanimously.

Consent Agenda:

MOTION by Commissioner Murphy to approve the consent agenda. SECOND
by Commissioner Witt. The motion carried unanimously.

- (1) 9-1-1 Communications Center - Apply for State E-911 Spring Rural Grant - Support & Maintenance - 911 Call Taking Equipment and Logging Recorders

- (2) BCC Administration - Assessment Programs Legal Services - \$16,500
- (3) BCC Administration - County Manager Annual Leave
- (4) BCC Administration - BA 19-36 - Award of the Preferred Training Incentive Program (TIP)- \$5,000
- (5) Building and Zoning - Special Family Lot Permit 19-07 - Ronald Throckmorton, Father - Lida Camille Throckmorton Property Owner - 220 SW Chinchilla Glen, High Springs, FL
- (6) Building and Zoning - Special Family Lot Permit 19-08 - Marrison Harrison, Daughter - Randall Harrison, Property Owner - 216 NE Pikes Way
- (7) Clerk to Board Finance - Approval of Bills and Vouchers - \$782,649
- (8) Emergency Management - Hurricane Irma Modification Z0618-2 – Reimbursement of Eligible Expenditures - \$2,184
- (9) Emergency Management - Modification Z0618-1 Hurricane Irma – Reimbursement of Eligible Expenditures - \$5,374
- (10) Human Resources - Unpaid Leave Request - Jordan Hoffman
- (11) Library - BA 19-35 - Friends of the Library Donation - \$1,300
- (12) Public Works - Utility Permit - FP&L Co. - Price Creek Road
- (13) Public Works - Utility Permit - True Net - SW King Street
- (14) Solid Waste - FDACS - Amendment to Mosquito Control Contract #025508

MOTION by Commissioner Witt to adopt the consent agenda.
 SECOND by Commissioner Ford. The motion carried unanimously.

Discussion and Action Items:

Interlocal Agreement for Sheriff's Annual Budget

At a special meeting on February 21, 2019, the Board directed staff to draft a letter to terminate the Interlocal Agreement for the Sheriff's Annual Budget.

A termination letter was presented to the Board for approval.

MOTION by Commissioner Nash to approve the termination letter for the Interlocal agreement for the Sheriff's annual budget. SECOND by Commissioner Murphy.

Sheriff Hunter addressed the Board and asked for assurances that the Board would always return his end of year monies and that they would not take his reserves.

Discussion ensued.

The Chairman called for the vote. The motion carried unanimously.

BA 19-37 Fort White Recreation Complex

Parking at the Fort White Recreation Complex has become an issue of safety due to the size of tournaments being held there. Just north of the facility is approximately 9.06 acres and would address the parking issue and allow for future growth.

MOTION by Commissioner Ford to approve BA 19-37 for \$160,000 to purchase land for future parking lot and other recreational uses. SECOND by Commissioner Murphy. The motion carried unanimously.

BA 19-38 State E-911 Grant

Staff is requesting approval to accept 2 State E-911 grants.

MOTION by Commissioner Witt to accept the grants and authorize the purchase of Datamaster Software.. SECOND by Commissioner Murphy. The motion carried unanimously.

Bell Road Utilities

Staff requested approval for the engineering and design of the utilities needed along Bell Road and alternatives should funding be limited. The utility design would cost \$107,700.

Citizen Stewart Lilker asked a question.

MOTION by Commissioner Nash to approve the engineering and design of the utilities along Bell Road and prepare alternatives. SECOND by Commissioner Murphy. The motion carried unanimously.

Open Public Comments and/or Questions:

Members of the public addressed the Board with their comments and/or questions regarding the following items:

Sandra Buck-Camp – Citizens should have input on the County Budget.

Trisha Cristison – the Sheriff’s K-9 Unit at the tractor show and thanked them for their support.

Robert Lane – the new jail.

Commissioner Comments:

Commissioner Williams asked Merrilee Malwitz-Jipson about her addressing Suwannee Valley Water Management concerning the restrooms at Rum Island. She responded.

Staff Comments:

County Attorney Foreman informed the Board that Waste Pro is pressing their franchise on permanent containers.

Adjournment

There being no further business, the meeting adjourned at 6:40 p.m.

ATTEST:

Ronald Williams, Chairman
Board of County Commissioners

P. DeWitt Cason
Clerk of Circuit Court



**COLUMBIA COUNTY BOARD OF COUNTY COMMISSIONERS
AGENDA ITEM REQUEST FORM**

The Board of County Commissioners meets the 1st and 3rd Thursday of each month at 5:30 p.m. in the Columbia County School Board Administrative Complex Auditorium, 372 West Duval Street, Lake City, Florida 32055. All agenda items are due in the Board's office one week prior to the meeting date.

Today's Date: 3/5/2019 **Meeting Date:** 3/21/2019

Name: Penny Stanley **Department:** BCC Administration

Division Manager's Signature: 

1. Nature and purpose of agenda item:

BCC Administration - Another Way, Inc. - Certification of Local Government Approval - Emergency Shelter Only

2. Recommended Motion/Action:

Requesting Approval

3. Fiscal impact on current budget.

This item has no effect on the current budget.

9.12 Local Government Certification

**Certification of Local Government Approval
 for ESG applying Nonprofit Organizations – Emergency Shelter Only
 Required by 24 CFR 576.202**

I, Ben Scott, County Manager (name and title) duly authorized to act on behalf of the County of Columbia (name of city or county government) hereby approve the submission of the following ESG application proposed by Another Way, Inc. (name of agency) which will serve persons living in Columbia County (name of city or county).

This certification solely warrants that the jurisdiction has agreed to allow the nonprofit organization to seek the grant to be able to serve citizen in need who reside in this jurisdiction. This certification places no responsibility or liability upon the local government jurisdiction related to the nonprofit's performance of grant-funded activities in our jurisdiction.

By: <u>Ben Scott</u> _____ (name)	<u>County Manager</u> _____ (title)
_____ (signature)	_____ (date)

This form must be signed, dated, and returned with the grant application in order for the application to be considered for funding.

United Way of Suwannee Valley
Homeless Services Network of Suwannee Valley
Project Proposal Form

FY 2019-2020 Unified Contract Application

Challenge Grant

Emergency Solutions Grant

Name of Agency/Organization: Another Way, Inc.

Agency Mailing Address: P.O. Box 1028, Lake City, FL 32056

Project Title and Brief Description: Another Way Emergency Shelter

Another Way provides emergency shelter and supportive services for survivors of domestic and sexual violence and their dependent children.

Project Location: Confidential Address - Lake City, Florida

Contact Person: Michelle Wichterman

Telephone: (386) 719-2700 E-mail address: michellewichterman@anotherwayinc.net Fax: (386) 719-2758

Approval of CEO or Executive Director

Name: Andrea M. Gottry Title: Executive Director

Signature: _____ Date: 12/13/2018

Amount of Funding Requested: \$ 74,000.00 Total Project Budget \$ 2,385,654.71

Federal Strategic Plan goal(s) addressed: Ensure homelessness is a brief experience.

Ensure homelessness is a one-time experience.

Sustain an end to homelessness.

HEARTH Act Performance Measure(s) applicable to proposed project:

Reduce average length of time persons are homeless.

Reduce number of families and individuals who are homeless.

HSNSV CoC Action Plan Strategy and Action Step addressed:

Provide immediate access to low-barrier emergency shelter to all who need it.

Prevent returns to homelessness through connections to adequate services and opportunities.

Sustain practices and systems at a scale necessary to respond to future needs.



**COLUMBIA COUNTY BOARD OF COUNTY COMMISSIONERS
AGENDA ITEM REQUEST FORM**

The Board of County Commissioners meets the 1st and 3rd Thursday of each month at 5:30 p.m. in the Columbia County School Board Administrative Complex Auditorium, 372 West Duval Street, Lake City, Florida 32055. All agenda items are due in the Board's office one week prior to the meeting date.

Today's Date: 3/15/2019 Meeting Date: 3/21/2019

Name: Ben Scott Department: BCC Administration

Division Manager's Signature: *Ben Scott*

1. Nature and purpose of agenda item:

Palms Medical Group is requesting a letter of support for a Federally Qualified Health Center New Access Point.

2. Recommended Motion/Action:

Approve drafting of letter of support.

3. Fiscal impact on current budget.

This item has no effect on the current budget.

From: Allyson Schmitz <aschmitz@palmsg.org>
Sent: Thursday, March 14, 2019 3:56 PM
To: lisa_roberts@columbiacountyfla.com
Subject: Letter of Support Request

Hey Lisa,

Palms Medical Group has submitted an application to Health Resources and Services Administration (HRSA) for a Federally Qualified Health Center (FQHC) New Access Point (NAP). This NAP will be located in Lake City, Florida and will help to ensure healthcare access to a substantial population of individuals and families. Palms Medical Group would be able to provide access to primary care and continuum of care for many of the most vulnerable and under-served in Lake City.

We are asking that you kindly write a letter of support so we can secure the funding to move forward with the New Access Point in Lake City. Palms Medical group currently has thirteen medical office locations that serve as a strong component of the local safety net of primary health care in North Central Florida. Your letter of support for this New Access Point in Lake City would be greatly appreciated.

To meet our HRSA deadline, we ask that you return your letter of support to me no later than Friday, March 22nd.

Please let me know if you have questions or concerns.

Thank you,

Allyson Schmitz
Marketing Specialist
Trenton Medical Center, Inc.,
dba Palms Medical Group
23343 NW County Road 236
High Springs, Florida 32643

This email and any files transmitted with it may contain PRIVILEGED or CONFIDENTIAL information and may be read or used only by the intended recipient. If you are not the intended recipient of the email or any of its attachments, please be advised that you have received this email in error and that any use, dissemination, distribution, forwarding, printing, or copying of this email or any attached files is strictly prohibited. If you have received this email in error, please immediately purge it and all attachments and notify the sender by reply email or contact the sender at the number listed.



**COLUMBIA COUNTY BOARD OF COUNTY COMMISSIONERS
AGENDA ITEM REQUEST FORM**

The Board of County Commissioners meets the 1st and 3rd Thursday of each month at 5:30 p.m. in the Columbia County School Board Administrative Complex Auditorium, 372 West Duval Street, Lake City, Florida 32055. All agenda items are due in the Board's office one week prior to the meeting date.

Today's Date: 3/15/2019 Meeting Date: 3/21/2019

Name: Donny Dupree Department: BCC Administration

Division Manager's Signature: 

1. Nature and purpose of agenda item:

Approval termite policy of the courthouse.

2. Recommended Motion/Action:

Approve

3. Fiscal impact on current budget.

This item is currently budgeted. The account number to be charged is 001-1830-519.30-46

SUBTERRANEAN TERMITE SERVICE POLICY AND LIMITED WARRANTY

(FOR RETREATMENT ONLY)

This agreement made this 10th day of FEBRUARY in the year of 2018 in the City of LAKE CITY

State of Florida by and between Florida Pest Control & Chemical Co., hereinafter called the First Party or Florida Pest or FPC and COLUMBIA CO COURTHOUSE of age and a resident of the City of LAKE CITY State of FL

who declares himself to be the owner, and/or agent of the owner, of the below named property, hereinafter called Owner or the Second Party. Second Party hereby asserts, confirms and warrants that he/she/it has read, understood, and agreed to this contract, and is/are the owner(s) of the subject property and covered structure, and/or the authorized agent or representative of any and all said owners, with full power and authority to execute this contract and forever bind all owners and their principals, agents, heirs, representatives, successors, and assigns.

Witnesseth:

1. FPC agrees to treat the property known as COURTHOUSE CONTACT- DONNIE DUPR at the address 173 NE HERNANDO ST LAKE CITY FLORIDA for the control

and/or prevention of subterranean termites. No buildings (structures) on the property, other than those specified above shall be included in and under this agreement. FPC will make re-inspections of the property yearly for as many years as the owner keeps this contract in force and FPC will give additional treatment at anytime during the life of this contract, if Subterranean Termite infestation is found; such annual re-inspections and re-treatment will be at no additional cost to the owner other than the annual renewal fee.

2. Second Party hereby agrees and binds himself to pay FPC upon completion of the initial work, as compensation for labor, material and service herein contracted for, the sum of Four Thousand Two Hundred Sixty-Eight (\$ 4,268.00) dollars, plus sales tax, to be paid as follows: Cash (), Check (), Credit Card (), Other K . This contract expires at the end of one year unless the option to renew is elected.

At the expiration of this one-year contract, the Second Party may take advantage of the yearly termite service offered with this contract by paying FPC the annual renewal fee of Five Hundred Thirty-Five (\$ 535.00) dollars, plus sales tax, each year NO LATER THAN 30 days after the Anniversary Date of this contract. FPC reserves the absolute right to adjust the annual renewal fee at the end of any contract year.

This contract contains disclaimers, conditions, limitations and exclusions.

3. **Terms of Limited Warranty: THIS IS A TREATMENT ONLY CONTRACT.** Since FPC did not have the opportunity to treat the entire structure during initial construction; or had no control over the treating specifications or method of initial preventive treatment; or that since the premises have not been maintained under a continuing termite service policy with annual inspections subsequent to initial treatment during the construction of the premises; and FPC has not had continuous supervision over the premises with uninterrupted annual inspections, FPC EXPRESSLY LIMITS ITS RESPONSIBILITY UNDER THIS CONTRACT TO ONLY THE TREATMENT OF ANY SUBSEQUENT INFESTATION; SUCH TREATMENT DOES NOT INCLUDE THE REPAIR, NOR REPLACEMENT OF, DAMAGED WOODWORK (OR ANY OTHER TYPE PROPERTY OR MATERIAL), IF ANY, WHICH SHOULD OR MAY RESULT FROM ANY INFESTATION.

4. **Specific Exclusions:** This Agreement does not cover and FPC will not be responsible for:

- a. Damage of any kind which results/ resulted in any way from moisture conditions, including, but not limited to, fungus or wood rot, whether visible or not; resulted in any way from wood in direct contact with the soil, whether visible or not; and/or resulted from alteration(s) or structural modifications.
- b. Exploratory costs & expenses to determine whether or not damage exists or existed, and /or to determine the extent of any damage.
- c. Personal expenses such as, but not limited to, lodging, meals, transportation, medical expenses, day care, moving and storage costs, etc. incurred as a result of treatment, re-treatment and/or damage repair.
- d. Loss of rental/income or any type business opportunity because of treatment, re-treatment or damage repair.
- e. Unless specifically indicated, this contract does not cover any other wood destroying organism.
- f. Damage of any and every kind resulting from a construction with stucco on wire lath on frame and/or rigid foam board and/or expanded foam materials and/or exterior siding in contact with the soil or covering interior or exterior foundation walls in such a way as to provide termites with hidden and/or protected access to the structure, whether visible or not.
- g. Damage of any kind to other than the covered structure, itself, such as, but not limited to, personal property and items in or around the covered structure.
- h. FPC agrees to use all reasonable care when providing initial and subsequent termite treatment in order to avoid damage to shrubs, vegetation and other property, but under no circumstances or conditions will FPC be responsible for damages to shrubs, vegetation, sprinklers, plumbing, wiring, cable, well, etc., occurring during treatment and control work, other than that caused by negligence on the part of FPC.

5. DISCLAIMER:

a. AS SOIL TREATMENT IS AN ESSENTIAL PART OF THE CONTROL OF SUBTERRANEAN TERMITES, THE SECOND PARTY AGREES AND COVENANTS NOT TO DISTURB THE SOIL WITHIN ONE FOOT OF EITHER SIDE OF THE BUILDING FOUNDATIONS OR EITHER SIDE OF THE STRUCTURE WHICH IS IN CONTACT WITH THE SOIL. IF, DURING THE TERM OF THIS CONTRACT, ADDITIONS OR ALTERATIONS ARE MADE WHICH AFFECT THE STRUCTURE AND CREATE NEW TERMITE HAZARDS, OR INTERFERE WITH THE CHEMICAL PROTECTIVE BARRIER, INCLUDING BUT NOT LIMITED TO LANDSCAPING, WOODEN DECKS, OR ANY ADDITION OR ALTERATION IN WHICH WOOD IS EXPOSED OR MAY BE IN CONTACT WITH THE GROUND, THIS CONTRACT WILL BECOME NULL AND VOID, AND FPC SHALL HAVE NO FURTHER RESPONSIBILITY.

b. THIS WARRANTY IS BASED ON THE USE OF A CHEMICAL BARRIER APPLIED TO THE SOIL. ANY TERMITE INFESTATION AND RESULTING DAMAGE WHICH DOES NOT OCCUR BY ACCESS FROM THE SOIL IS EXCLUDED FROM THIS COVERAGE.

c. MOISTURE PROBLEMS ABOVE GROUND LEVEL OR IN THE STRUCTURE, ARE THE RESPONSIBILITY OF THE SECOND PARTY, AND IF NOT IMMEDIATELY CORRECTED AND ATTENDED TO, CAN PROVIDE A SUPPLY OF MOISTURE WHICH SUPPORTS AN ABOVE-GROUND INFESTATION WHICH IS NOT COVERED BY THIS WARRANTY.

d. NOTWITHSTANDING ANY LANGUAGE TO THE CONTRARY HEREIN SET FORTH, THIS LIMITED WARRANTY DOES NOT APPLY TO ANY INFESTATION OR DAMAGE RESULTING FROM MOISTURE OR DAMPNESS PROBLEMS ASSOCIATED WITH MOISTURE ACCUMULATION CAUSED BY ANY NATURAL OR MAN-MADE SOURCE, INCLUDING, BUT NOT LIMITED TO, ACCUMULATION, CONDENSATION, OR LEAKS FROM EXTERIOR WALLS, ROOFS, SKYLIGHTS, CHIMNEYS, GUTTERS, DOWN SPOUTS, PLUMBING, PLUMBING FIXTURES, AIR CONDITIONING AND HEATING EQUIPMENT AND ASSOCIATED PIPES, PANS, AND DUCT WORK, INADEQUATE VENTILATION, POOR DRAINAGE, SOIL WASHOUT, ETC. IN ADDITION, THIS WARRANTY DOES NOT APPLY WHERE WOOD, SUCH AS, BUT NOT LIMITED TO, POSTS, FORM BOARDS, FORM & GRADE STAKES, LUMBER, TRASH, DEBRIS, ETC., WERE/HAS BEEN/ARE IN DIRECT CONTACT WITH THE SOIL, AND/OR COVERED BY OR BURIED UNDER THE FOUNDATION, OR WHERE OPEN AREAS/SPACES OR CRACKS EXISTED/EXIST IN THE FOUNDATION SLAB.

e. UNDER NO CIRCUMSTANCES SHALL FPC BE RESPONSIBLE FOR ANY REPAIRS NOR TO PAY THE COSTS FOR LABOR AND MATERIALS TO LOCATE, IDENTIFY AND/OR REPLACE ANY DAMAGED WOODWORK.

f. UNLESS SPECIFICALLY COVERED BY AN ADDENDUM TO THIS CONTRACT, CONTROL OF THE FORMOSAN SUBTERRANEAN TERMITE (COPTOTERMES FORMOSANUS) IS SPECIFICALLY EXCLUDED FROM THE PROVISIONS OF THE CONTRACT, IN THAT CONTROL PROCEDURES DIFFER FROM THOSE USED FOR THE CONTROL OF NATIVE SUBTERRANEAN TERMITE SPECIES.

g. THE LIMITED WARRANTY OFFERED HEREIN CONSTITUTES THE ENTIRE WARRANTY, AND IS EXPRESSLY LIMITED TO AND BY THE PROVISIONS SET FORTH ABOVE. ALL OTHER WARRANTIES OR GUARANTEES, EITHER EXPRESSED OR IMPLIED, ARE HEREBY EXPRESSLY DISCLAIMED.

Owner/ Second Party:

Florida Pest Control & Chemical Co.

DATE: _____

By: [Signature]

DATE: _____

Treatment notice posted: BY ELECTRICAL PANEL

Subterranean Termite Service Policy and Limited Warranty, continued:

6. **Financing.** Any unpaid balance to bear interest at the rate of one and one-half (1-1/2)% per month, which is a FINANCE CHARGE, with an ANNUAL PERCENTAGE RATE of 18% on the unpaid balance.

7. **Structural Changes, Additions, Alterations:** In the event of any additions and/or alterations to the treated structure, or to the landscaping and lawn within 1 foot of the structure, Second Party must promptly notify FPC in writing of such changes and arrange with FPC for additional service, which may require additional service charges and/or adjustment in the annual renewal fee. This Agreement covers only the structure(s) identified. Since changes create new termite hazards, in the event the structure(s) is (are) modified, altered or otherwise changed, Second Party will immediately notify FPC for proper instructions and/or any additional treatment/monitoring required by the changes made. Failure to so notify FPC will void any and all warranties under this contract and will terminate this agreement automatically, effective the date the change was first begun on the structure(s) or surrounding land. FPC will require additional service charges and/or reserves the right to adjust the annual renewal fee, because of the increased risk caused by the changes.

8. **Transfer of ownership:** Second Party agrees to immediately notify FPC of any pending transfer of ownership of the property. Annual renewal fees will not be refunded. While this policy may be transferred to the new owner, FPC, at its sole option and discretion, reserves the absolute right to transfer or not transfer this agreement.

9. **Cancellation Clause:** This contract may be canceled for any reason, within 30 days before or after the Anniversary Date of this contract by either party in writing to be effective the day the current contract ends.

10. **Change in Law:** FPC performs its services in accordance with the requirements of the Environmental Protection Agency (EPA), Federal, State, and Local laws. In the event of a change in existing law as it pertains to the services promised herein, FPC reserves the right to amend or terminate this agreement.

11. **Entire Agreement:** This contract is the sole and entire agreement between the parties, and supercedes, replaces, and/or is an accord and satisfaction of any and all prior understandings, agreement(s), or contract(s) for the subject property (structures) or between the parties. Any and all modifications, changes, or waivers must be in writing and signed by both parties.

12. **Arbitration Agreement:** Second Party and FPC hereby specifically agree and covenant that any and all controversies or claims between them, their principals, agents, representatives, successors, or assigns, arising in any way out of, or relating to, this agreement, and/or the subject property, and/or subject structure(s), and/or the termite treatment, shall be settled solely and exclusively by arbitration. Such arbitration shall be conducted in the Florida County where the servicing FPC office for this agreement is located at that time, using the substantive law of Florida, and in accordance with the Commercial Arbitration Rules then in force of the American Arbitration Association. The arbitrator shall be independent, mutually agreed upon, and to the greatest extent possible, be qualified in termite control and building construction matters by education, experience, licensing and training to deal with the issues. The decision of the arbitrator shall be a final and binding resolution of the disagreement, which may be entered as a judgment by any court of Competent jurisdiction. Neither party shall sue the other where the basis of the suit is in any way this agreement, or arises out of this agreement, other than for (1) enforcement of the arbitrator's decision, or (2) appointment of an arbitrator if one cannot be mutually agreed upon. The parties specifically agree that the sole and exclusive venue of any suit shall be Alachua County, Florida. In no event shall either party be liable to the other for indirect, special, consequential, or punitive damages, loss of anticipated or actual profits, income or business opportunities; or living expenses of any kind (e.g. room, board, medical, gas, utilities, etc.). All costs, expenses, and fees of arbitration and settling a controversy shall be borne equally by the parties. This arbitration provision shall survive cancellation, expiration, or termination of this contract.

13. **CHEMICAL SENSITIVITY: SECOND PARTY ACKNOWLEDGES AND UNDERSTANDS THAT CHEMICALS ARE USED TO PROVIDE THE REQUESTED TREATMENT, AND SECOND PARTY HEREBY SPECIFICALLY ACCEPTS AND AGREES THAT HE/SHE/THEY/IT HAS THE SOLE BURDEN TO CLEARLY AND AFFIRMATIVELY INFORM FPC OF ANY AND ALL CHEMICAL SENSITIVITY OR ALLERGIES, AND HEREBY COVENANTS AND WARRANTS THAT NEITHER HE/SHE/THEY/IT NOR ANYONE RESIDING, WORKING OR FREQUENTING THE PREMISES, ARE SENSITIVE OR ALLERGIC TO SAID CHEMICALS.**

Acknowledged and accepted by Owner/ Second Party:

_____ DATE: _____
_____ DATE: _____

p. 25



COLUMBIA COUNTY BOARD OF COUNTY COMMISSIONERS AGENDA ITEM REQUEST FORM

The Board of County Commissioners meets the 1st and 3rd Thursday of each month at 5:30 p.m. in the Columbia County School Board Administrative Complex Auditorium, 372 West Duval Street, Lake City, Florida 32055. All agenda items are due in the Board's office one week prior to the meeting date.

Today's Date: 3/12/2019 Meeting Date: 3/21/2019

Name: Laurie Hodson Department: Building And Zoning

Division Manager's Signature:

A handwritten signature in blue ink that reads "Ben Scott".

1. Nature and purpose of agenda item:

Special Family Lot Permit #19 09 from Robert & Janice Cox, owners to deed 1.00 acre to Catherine Todd, daughter for residential use.

2. Recommended Motion/Action:

Approval

3. Fiscal impact on current budget.

This item has no effect on the current budget.



Columbia County Gateway to Florida

FOR PLANNING USE ONLY	
Application # SFLP	<u>1909</u>
Application Fee \$50.00	
Receipt No.	<u>5019</u>
Filing Date	<u>3-12-19</u>
Completeness Date	<u>3-12-19</u>

Special Family Lot Permit Application

A. PROJECT INFORMATION

- Title Holder's Name: Robert Lewis + Janice G Cox
- Address of Subject Property: 303 SE Rodney Dicks Dr, Lake City FL 32025
- Parcel ID Number(s): 36-45-17-09049-005
- Future Land Use Map Designation: Agriculture
- Zoning Designation: A-3
- Acreage of Parent Parcel: 16.30
- Acreage of Property to be Deeded to Immediate Family Member: 1.01
- Existing Use of Property: Farmland
- Proposed use of Property: Homestead
- Name of Immediate Family Member for which Special Family Lot is to be Granted: Catherine Todd - Daughter

PLEASE NOTE: Immediate family member must be a parent, grandparent, adopted parent, stepparent, sibling, child, adopted child, stepchild, or grandchild of the person who is conveying the parcel to said individual.

B. APPLICANT INFORMATION

- Applicant Status Owner (title holder) Agent
- Name of Applicant(s): Robert Lewis + Janice G Cox Title: _____
 Company name (if applicable): _____
 Mailing Address: 303 SE Rodney Dicks Drive
 City: Lake City State: FL Zip: 32025
 Telephone: (386) 965-0414 Fax: () Email: _____

PLEASE NOTE: Florida has a very broad public records law. Most written communications to or from government officials regarding government business is subject to public records requests. Your e-mail address and communications may be subject to public disclosure.

- If the applicant is agent for the property owner*.
 Property Owner Name (title holder): N/A
 Mailing Address: _____
 City: _____ State: _____ Zip: _____
 Telephone: () Fax: () Email: _____

PLEASE NOTE: Florida has a very broad public records law. Most written communications to or from government officials regarding government business is subject to public records requests. Your e-mail address and communications may be subject to public disclosure.

*Must provide an executed Property Owner Affidavit Form authorizing the agent to act on behalf of the property owner.

C. ATTACHMENT/SUBMITTAL REQUIREMENTS

1. Map, Drawing, or Sketch of Parent Parcel Showing the Location of the Proposed Lot being Deeded to Immediate Family Member with Appropriate Dimensions (Must be a Minimum of One Acre).
2. Personal Identification and Proof of Relationship, to Establish the Required Immediate Family Member Status, of both the Parent Parcel Owner and the Immediate Family Member. The Personal Identification Shall Consist of Original Documents or Notarized Copies from Public Records. Such Documents may include Birth Certificates, Adoption Records, Marriage Certificates, and/or Other Public Records.
3. Family Relationship Residence Agreement Affidavit is Required Stating that the Special Family Lot is being Created as a Homestead by the Immediate Family Member, that the Immediate Family Member shall obtain Homestead Exemption on the Lot. This Affidavit shall be Recorded in the Clerk of Courts Office.
4. Legal Description of Parent Parcel with Acreage (In Microsoft Word Format).
5. Legal Description of Property to be Deeded to Immediate Family Member with Acreage (In Microsoft Word Format).
6. Legal Description of Parent Parcel with Immediate Family Member Lot Removed with Acreage (In Microsoft Word Format).
7. Proof of Ownership (i.e. deed).
8. Agent Authorization Form, if applicable (signed and notarized).
9. Proof of Payment of Taxes (can be obtained online via the Columbia County Tax Collector's Office).
10. Fee. \$50.00 - No application shall be accepted or processed until the required application fee has been paid.

NOTICE TO APPLICANT

A special family lot permit may be issued by the Board of County Commissioners on land zoned Agricultural or Environmentally Sensitive Area within these Land Development Regulations, for the purpose of conveying a lot or parcel to an immediate family member who is the parent, grandparent, adopted parent, stepparent, sibling, child, or adopted child, stepchild or grandchild of the person who conveyed the parcel to said individual, **not to exceed one (1) dwelling unit per one (1) acre** and the lot complies with all other conditions from permitting development as set forth in these Land Development Regulations. This provision is intended to promote the perpetuation of the family homestead in rural areas by making it possible for immediate family members to reside on lots as their primary residence which exceed maximum density for such areas, provided that the lot complies with the conditions for permitting established in Section 14.9 of the Land Development Regulations.

If approved by the Board of County Commissioner, the division of lots shall be recorded by separate deed, comply with all other applicable regulations of the Land Development Regulations, and comply with all other conditions for permitting and development as set forth in the Land Development Regulations. A completed building permit application shall be submitted within one (1) year of receiving approval by the Board of County Commissioners. One (1) extension can be requested in writing and approved by the Land Development Regulations Administrator not to exceed nine (9) months. If a special family lot permit expires, it shall have to go through the process again for approval as required by this section. A building permit for a special family lot shall be issued only to the immediate family member or their authorized representative (i.e. licensed building contractor or mobile home installer) after a recorded copy of the family relationship residence agreement affidavit and deed to the special family lot has been submitted to the Land Development Regulation Administrator as part of the building permit application process.

Special family lots which have not met the requirements for homestead exemption shall not be transferable except, as follows:

1. The deeding of the parcel back to the original owner of the parent tract as indicated in Section 14.9 of the Land Development Regulations;
2. To another individual meeting the definition of immediate family member;
3. To an individual not meeting the definition of immediate family member due to circumstances beyond the reasonable control of the family member to whom the original special family lot permit was granted such as divorce, death or job change resulting in unreasonable commuting distances, the immediate family member is no longer able to retain ownership of the special family lot, subject to approval by the original reviewing body that approved the special family lot permit; and
4. Upon approval of the transfer of the special family lot, the County will issue a Certificate of Transfer and the owner shall record the certificate in the Public Records in the Clerk of the Courts Office. This process shall apply retroactively to special family lots previously created under the Land Development Regulations.

Any decision made by the Board of County Commissioners is subject to a 30 day appeal period as outlined in Article 12 of the Land Development Regulations. Any action taken by the applicant within the 30 day appeal period is at the applicant's risk. No Certificate of Occupancy shall be issued until the 30 day appeal period is over or until any appeal has been settled.

Upon the applicant obtaining a Certificate of Occupancy, the applicant must file for Homestead Exemption. Homestead Exemptions can be filed each year with the Columbia County Property Appraiser's Office from January 1 to March 31.

Once an application is submitted and paid for, a completeness review will be done to ensure all the requirements for a complete application have been met. If there are any deficiencies, the applicant will be notified in writing. If an application is deemed to be incomplete, it may cause a delay in the scheduling of the application before the Planning & Zoning Board.

THE APPLICANT ACKNOWLEDGES THAT THE APPLICANT OR AGENT MUST BE PRESENT AT THE PUBLIC HEARING BEFORE THE PLANNING AND ZONING BOARD, AS ADOPTED IN THE BOARD RULES AND PROCEDURES, OTHERWISE THE REQUEST MAY BE CONTINUED TO A FUTURE HEARING DATE.

I hereby certify that all of the above statements and statements contained in any documents or plans submitted herewith are true and accurate to the best of my knowledge and belief.

Janice G Cox

Applicant/Agent Name (Type or Print)

Janice G Cox

Applicant/Agent Signature

3-17-19

Date

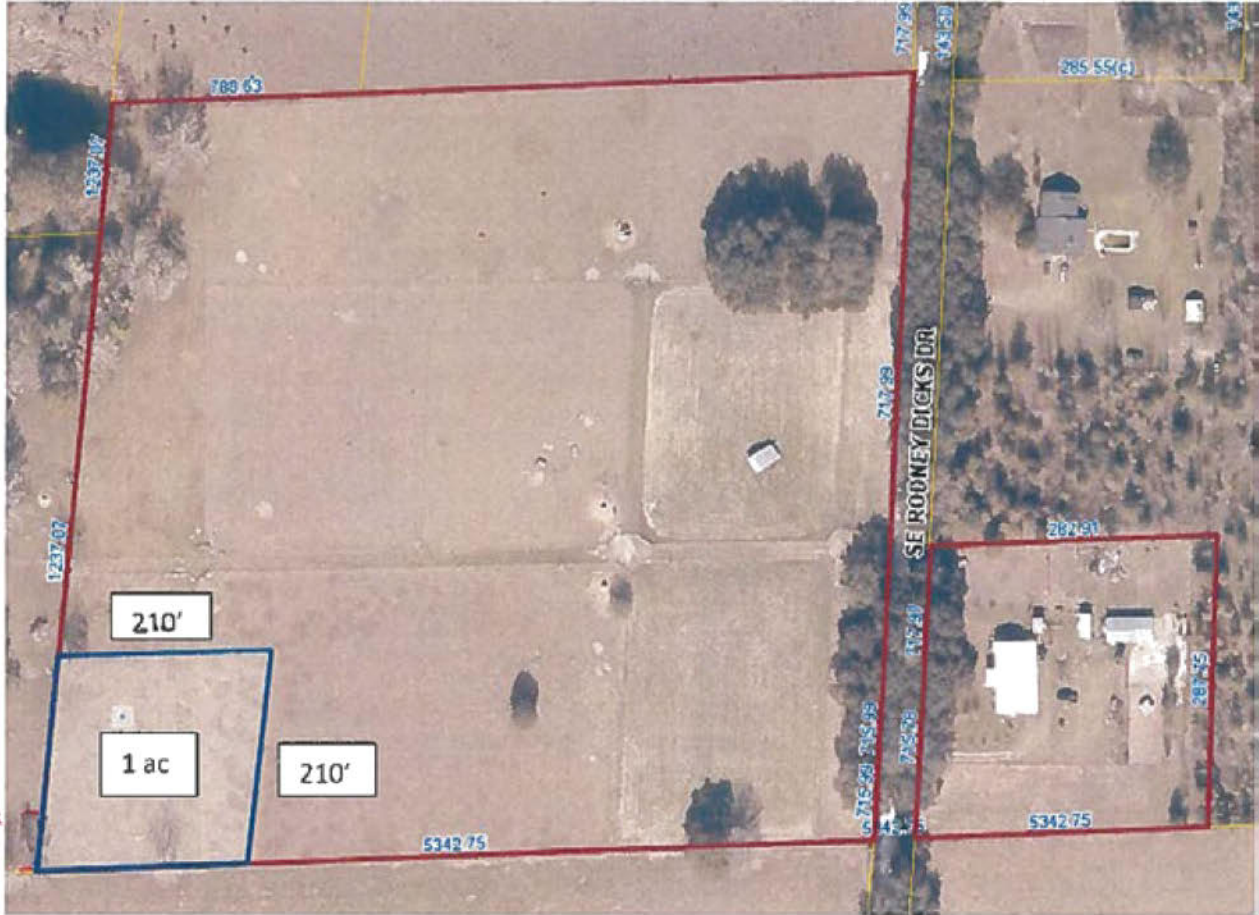

Parent Parcel – 09049-005 – (16.30 ac)

Deeded Property – 09049-015 (1.00 ac)

THIGPIN LORETTA COX

09049-007

SE ROBERT COX Ter

09049-005

COX ROBERT LEWIS & JANICE G

36

TODD GREG F & CATHERINE E

09049-000

09049-015

1.01
Ac

TODD GREG &

SEC COUNTY ROAD 245

30' Easement

6
Ac

1

09053-000

DICKS NORMA R AS 1 inch = 83 feet

FAMILY RELATIONSHIP AFFIDAVIT

STATE OF FLORIDA
COUNTY OF COLUMBIA

BEFORE ME the undersigned Notary Public personally appeared, Robert Lewis Cox
and Janice G. Cox the Owner of the parent parcel which has been subdivided for and
Greg + Catherine Todd the Immediate Family Member of the Owner, which is
intended for the Immediate Family Members primary residence use. The Immediate Family
Member is related to the Owner as daughter. Both individuals being
first duly sworn according to law, depose and say:

1. Affiant acknowledges Immediate Family Member is defined as parent, grandparent, step-parent, adopted parent, sibling, child, step-child, adopted child or grandchild.
2. Both the Owner and the Immediate Family Member have personal knowledge of all matters set forth in this Affidavit.
3. The Owner holds fee simple title to certain real property situated in Columbia County, and more particularly described by reference with the Columbia County Property Appraiser Parent Tract Tax Parcel No. 36-48 17-09049-005
4. The Immediate Family Member holds fee simple title to certain real property divided from the Owners' parent parcel situated in Columbia County and more particularly described by reference to the Columbia County Property Appraiser Tax Parcel No. 36-48 17-09049-015
5. No person or entity other than the Owner and Immediate Family Member to whom permit is being issued, including persons residing with the family member claims or is presently entitled to the right of possession or is in possession of the property, and there are no tenancies, leases or other occupancies that affect the property.
6. This Affidavit is made for the specific purpose of inducing Columbia County to recognize a family division for an Immediate Family Member being in compliance with the density requirements of the Columbia County's Comprehensive Plan and Land Development Regulations (LDR's).
7. This Affidavit and Agreement is made and given by Affiants with full knowledge that the facts contained herein are accurate and complete, and with full knowledge that the penalties under Florida law for perjury include conviction of a felony of the third degree.

We Hereby Certify that the facts represented by us in this Affidavit are true and correct and we accept the terms of the Agreement and agree to comply with it.

Janice G. Cox
Robert Lewis Cox
Owner

Catherine Todd
Greg Todd
Immediate Family Member

Robert Lewis Cox + Janice G. Cox
Typed or Printed Name

Greg + Catherine Todd
Typed or Printed Name

Subscribed and sworn to (or affirmed) before me this 8 day of March, 2019
by Robert & Gloria Cox (Owner) who is personally known to me or has produced
FLDL's as identification.

[Signature]
Notary Public



Subscribed and sworn to (or affirmed) before me this 8 day of March, 2019
by Greg & Catherine Todd (Family Member) who is personally known to me or has
produced FLDL's as identification.

[Signature]
Notary Public



APPROVED:
COLUMBIA COUNTY, FLORIDA

By: _____
Name: _____
Title: _____

Legal Description for 1 Acre and 30 Foot Easement

COMMENCE AT THE SW CORNER OF SECTION 36, TOWNSHIP 4 SOUTH, RANGE 17 EAST, COLUMBIA COUNTY, FLORIDA AND RUN THENCE N 87°52'13" E., ALONG THE SOUTH LINE OF SAID SECTION 36, 1798.33 FEET TO THE POINT OF BEGINNING, THENCE CONTINUE N 87°52'13" E., 210.00 FEET; THENCE N 05°02'28" E., 210.00 FEET; THENCE S 87°52'13" W, 210.00 FEET; THENCE S 05°02'28" W., 210.00 FEET TO THE POINT OF BEGINNING. PARCEL CONTAINS 1.01 ACRES, MORE OR LESS.

TOGETHER WITH AN EASEMENT FOR INGRESS AND EGRESS AS LIES 30.00 FEET TO THE RIGHT (NORTH) OF THE FOLLOWING DESCRIBED LINE:

COMMENCE AT THE SW CORNER OF SECTION 36, TOWNSHIP 4 SOUTH, RANGE 17 EAST, COLUMBIA COUNTY, FLORIDA AND RUN THENCE N 87°52'13" E, ALONG THE SOUTH LINE OF SAID SECTION 36, 1798.33 FEET TO THE POINT OF BEGINNING; THENCE RUN S 87°52'13" W, 326.41 FEET TO A POINT ON THE EASTERLY RIGHT-OF-WAY LINE OF SE COUNTY ROAD NO.245 AND TO THE POINT OF TERMINATION. SAID EASEMENT IS TO EXTEND OR CONTRACT AS NEEDED TO CREATE THE BOUNDARIES THEREOF.

Recording Fees: \$ _____
Documentary Stamps: + _____
Total: \$ _____

Prepared By And Return To
TITLE OFFICES, LLC
1089 SW MAIN BLVD.,
LAKE CITY, FL. 32025

Inst: 2003017248 Date: 08/14/2003 Time: 08:45

File # 03Y-07061KW/KIM WATSON

Doc Stamp-Deed : 0.70

Property Appraisers Parcel I.D. Number(s):
09049-005

JKK DC, P. DeWitt Cason, Columbia County B:991 P:1625

WARRANTY DEED

THIS WARRANTY DEED made and executed the 14th day of August, 2003 by ROBERT LEWIS COX, JOINED BY HIS WIFE JANICE G. COX, hereinafter called the Grantor, to ROBERT LEWIS COX and JANICE G. COX, HIS WIFE, whose post office address is: RT. 3, BOX 78-3, LAKE CITY, FLORIDA 32025, hereinafter called the Grantee:

(Wherever used herein the terms "Grantor" and "Grantee" shall include singular and plural, heirs, legal representatives, and assigns of individuals, and the successors and assigns of corporations, wherever the context so admits or requires.)

WITNESSETH: That the Grantor, for and in consideration of the sum of TEN DOLLARS (\$10.00) and other valuable considerations, receipt whereof is hereby acknowledged, by these presents does grant, bargain, sell, alien, remise, release, convey and confirm unto the Grantee all that certain land situate, lying and being in COLUMBIA County, State of Florida, viz:

SEE EXHIBIT "A" ATTACHED HERETO AND MADE A PART HEREOF

TOGETHER with all the tenements, hereditaments and appurtenances thereto belonging or in anywise appertaining.

TO HAVE AND TO HOLD the same in fee simple forever.

AND the Grantor hereby covenants with said Grantee that the Grantor is lawfully seized of said land in fee simple; that the Grantor has good right and lawful authority to sell and convey said land, and hereby warrants the title to said land and will defend the same against the lawful claims of all persons whomsoever; and that said land is free of all encumbrances, except easements, restrictions and reservations of record, if any, and taxes accruing subsequent to December 31, 2002.

IN WITNESS WHEREOF, the said Grantor has signed and sealed these presents the day and year first above written.

Signed, sealed and delivered
in the presence of:

Martha Bryan
Witness: MARTHA BRYAN

Regina Simpkins
Witness: Regina Simpkins

Robert Lewis Cox
ROBERT LEWIS COX

Address:
Janice G. Cox
JANICE G. COX

STATE OF FLORIDA
COUNTY OF COLUMBIA

I hereby certify that on this day, before me, an officer duly authorized in the State and County aforesaid to take acknowledgments, personally appeared ROBERT LEWIS COX AND JANICE G. COX, HIS WIFE, who produced the identification described below, and who acknowledged before me that they executed the foregoing instrument.
Witness my hand and official seal in the county and state aforesaid this 14th day of August, 2003.



Martha Bryan
MY COMMISSION # CC656813 EXPIRES
August 10, 2003
BORN 08/10/1950 DAYTOWN, MISSISSIPPI

Martha Bryan
Notary Public:
Identification Examined: Drivers
Commission Expires: _____

03Y-07061

EXHIBIT "A"

A PART OF SECTION 36, TOWNSHIP 4 SOUTH, RANGE 17 EAST, DESCRIBED AS FOLLOWS: COMMENCE AT THE S.W. CORNER OF SECTION 36, TOWNSHIP 4 SOUTH, RANGE 17 EAST; THENCE ALONG THE SOUTH SECTION LINE OF SECTION 36 ON A BEARING OF N 89°28'19" EAST A DISTANCE OF 2646.08 FEET TO THE POINT OF BEGINNING. FROM THE POINT OF BEGINNING GO S 89°28'19" WEST, A DISTANCE OF 847.86 FEET; THENCE N 06°39'59" EAST, A DISTANCE OF 753.29 FEET; THENCE N 88°43'16" EAST, A DISTANCE OF 821.29 FEET; THENCE S 04°34'29.4" WEST, A DISTANCE OF 473.64 FEET; THENCE N 89°28'19" EAST, A DISTANCE OF 287.50 FEET; THENCE S 04°34'29.4" WEST, A DISTANCE OF 287.50 FEET; THENCE S 89°28'19" WEST, A DISTANCE OF 287.50 FEET TO THE POINT OF BEGINNING.

Inst:2003017248 Date:08/14/2003 Time:08:45

Doc Stamp-Deed : 0.70

MLK DC, P. DeWitt Cason, Columbia County B:991 P:1626

Columbia County Tax Collector

generated on 3/12/2019 11:36:56 AM EDT

Tax Record

Last Update: 3/12/2019 11:35:51 AM EDT

Ad Valorem Taxes and Non-Ad Valorem Assessments

The information contained herein does not constitute a title search and should not be relied on as such

Account Number R09049-005		Tax Type REAL ESTATE		Tax Year 2018	
Mailing Address COX ROBERT LEWIS & JANICE G 303 SE RODNEY DICKS DRIVE LAKE CITY FL 32025		Property Address 303 RODNEY DICKS SE		GEO Number 364S17-09049-005	
Exempt Amount See Below		Taxable Value See Below			
Exemption Detail HX 25000		Millage Code 003		Escrow Code	
Legal Description (click for full description) 36-4S-17 5000/500016.30 Acres COMM SW COR OF SEC, RUN E 2646.08 FT FOR POB. RUN W 847.86 FT, N 753.29 FT, E 821.29 FT, S 473.64 FT, E 287.50 FT, S 287.50 FT, W 287.50 FT TO POB. ORB 762-1563 WD 991-1625.					
Ad Valorem Taxes					
Taxing Authority	Rate	Assessed Value	Exemption Amount	Taxable Value	Taxes Levied
BOARD OF COUNTY COMMISSIONERS	8.0150	43,744	25,000	\$18,744	\$150.53
COLUMBIA COUNTY SCHOOL BOARD					
DISCRETIONARY	0.7480	43,744	25,000	\$18,744	\$14.00
LOCAL	4.2010	43,744	25,000	\$18,744	\$78.74
CAPITAL OUTLAY	1.5000	43,744	25,000	\$18,744	\$8.81
SUWANNEE RIVER WATER MGT DIST	0.3948	43,744	25,000	\$18,744	\$7.40
LAKE SHORE HOSPITAL AUTHORITY	0.9620	43,744	25,000	\$18,744	\$18.00
Total Millage		15.8208		Total Taxes	
				\$296.54	
Non-Ad Valorem Assessments					
Code	Levying Authority	Amount			
FFIR	FIRE ASSESSMENTS	\$219.98			
GGAR	SOLID WASTE - ANNUAL	\$193.00			
Total Assessments				\$412.98	
Taxes & Assessments				\$709.52	
If Paid By				Amount Due	
				\$0.00	

Date Paid	Transaction	Receipt	Item	Amount Paid
11/5/2018	PAYMENT	1200147.0001	2018	0.00

Prior Years Payment History

Prior Year Taxes Due

NO DELINQUENT TAXES

This Instrument Prepared by & return to:
Name: GREG TODD
Address: 273 SE ROBERT COX TERRACE
LAKE CITY, FLORIDA 32025

Inst: 201912005906 Date: 03/12/2019 Time: 10:05AM
Page 1 of 2 B: 1380 P: 07, P. DeWitt Cason, Clerk of Court Columbia
County, By: BD
Deputy Clerk

Parcel I.D. #: PART OF R09049-005 and R09049-000

SP: _____ LINE FOR PROCESSING D.I.L. _____ SPACE ABOVE THIS LINE FOR RECORDING D.I.L. _____

THIS WARRANTY DEED Made the 12th day of March, A.D. 2019, by **GREG TODD and CATHERINE TODD, HIS WIFE**, hereinafter called the grantors, to **GREG TODD and CATHERINE TODD, HIS WIFE**, whose post office address is **273 SE ROBERTS COX TERRACE, LAKE CITY, FL 32025**, hereinafter called the grantees:

(Wherever used herein the terms "grantors" and "grantees" include all the parties to this instrument, singular and plural, the heirs, legal representatives and assigns of individuals and the successors and assigns of corporations, wherever the context so admits or requires.)

Witnesseth: That the grantors, for and in consideration of the sum of \$10.00 and other valuable consideration, receipt whereof is hereby acknowledged, do hereby grant, bargain, sell, alien, remise, release, convey and confirm unto the grantees all that certain land situate in **Columbia County, State of Florida**, viz:

See Exhibit "A"

THIS DEED WAS PREPARED WITHOUT THE BENEFIT OF A TITLE SEARCH OR SURVEY AND MAKES NO WARRANTIES AGAINST SAME.

Together with all the tenements, hereditaments and appurtenances thereto belonging or in anywise appertaining

To Have and to Hold the same in fee simple forever.

And the grantors hereby covenant with said grantees that they are lawfully seized of said land in fee simple; that they have good right and lawful authority to sell and convey said land, and hereby fully warrant the title to said land and will defend the same against the lawful claims of all persons whomsoever, and that said land is free of all encumbrances, except taxes accruing, to and including December 31, 2019.

In Witness Whereof, the said grantors have signed and sealed these presents, the day and year first above written.

Signed, sealed and delivered in the presence of:

Bruce Brown

Witness Signature
Bruce Brown

Printed Name

Maria M. Landin

Witness Signature

Maria M. Landin

Printed Name

Greg Todd L.S.

GREG TODD

Address:

273 SE ROBERTS COX TERRACE, LAKE CITY,
FL 32025

Catherine Todd L.S.

CATHERINE TODD

Address:

273 SE ROBERTS COX TERRACE, LAKE CITY,
FL 32025

STATE OF FLORIDA
COUNTY OF COLUMBIA

The foregoing instrument was acknowledged before me this 12th day of March, 2019, by **GREG TODD and CATHERINE TODD**, who are known to me or who have produced _____ as identification.



Maria M. Landin
Notary Public
My commission expires 9/18/22

Exhibit "A"

COMMENCE AT THE SW CORNER OF SECTION 36, TOWNSHIP 4 SOUTH, RANGE 17 EAST, COLUMBIA COUNTY, FLORIDA AND RUN THENCE N 87°52'13" E., ALONG THE SOUTH LINE OF SAID SECTION 36, 1798.33 FEET TO THE POINT OF BEGINNING; THENCE CONTINUE N 87°52'13" E., 210.00 FEET; THENCE N 05°02'28" E., 210.00 FEET; THENCE S 87°52'13" W, 210.00 FEET; THENCE S 05°02'28" W, 210.00 FEET TO THE POINT OF BEGINNING.

TOGETHER WITH AN EASEMENT FOR INGRESS AND EGRESS AS LIES 30.00 FEET TO THE RIGHT (NORTH) OF THE FOLLOWING DESCRIBED LINE:

COMMENCE AT THE SW CORNER OF SECTION 36, TOWNSHIP 4 SOUTH, RANGE 17 EAST, COLUMBIA COUNTY, FLORIDA AND RUN THENCE N 87°52'13" E, ALONG THE SOUTH LINE OF SAID SECTION 36, 1798.33 FEET TO THE POINT OF BEGINNING; THENCE RUNS 87°52'13" W, 326.41 FEET TO A POINT ON THE EASTERLY RIGHT-OF-WAY LINE OF SE COUNTY ROAD NO. 245 AND TO THE POINT OF TERMINATION. SAID EASEMENT IS TO EXTEND OR CONTRACT AS NEEDED TO CREATE THE BOUNDARIES THEREOF.

DESCRIPTION:
 COMMENCE AT THE SW CORNER OF SECTION 36, TOWNSHIP 4 SOUTH, RANGE 17 EAST, COLUMBIA COUNTY, FLORIDA AND RUN THENCE N.87°52'13"E., ALONG THE SOUTH LINE OF SAID SECTION 36, 1798.33 FEET TO THE POINT OF BEGINNING; THENCE CONTINUE N.87°52'13"E., 210.00 FEET; THENCE N.05°02'28"E., 210.00 FEET; THENCE S.87°52'13"W., 210.00 FEET; THENCE S.05°02'28"W., 210.00 FEET TO THE POINT OF BEGINNING. PARCEL CONTAINS 1.01 ACRES, MORE OR LESS.

TOGETHER WITH AN EASEMENT FOR INGRESS AND EGRESS AS LIES 30.00 FEET TO THE RIGHT (NORTH) OF THE FOLLOWING DESCRIBED LINE:
 COMMENCE AT THE SW CORNER OF SECTION 36, TOWNSHIP 4 SOUTH, RANGE 17 EAST, COLUMBIA COUNTY, FLORIDA AND RUN THENCE N.87°52'13"E., ALONG THE SOUTH LINE OF SAID SECTION 36, 1798.33 FEET TO THE POINT OF BEGINNING; THENCE RUN S.87°52'13"W., 326.41 FEET TO A POINT ON THE EASTERLY RIGHT-OF-WAY LINE OF SE COUNTY ROAD NO. 245 AND TO THE POINT OF TERMINATION. SAID EASEMENT IS TO EXTEND OR CONTRACT AS NEEDED TO CREATE THE BOUNDARIES THEREOF.

SURVEYOR'S NOTES:

- BOUNDARY BASED ON MONUMENTATION FOUND.
- BEARINGS ARE BASED ON AN ASSUMED BEARING OF N.87°52'13"E. FOR THE SOUTH LINE OF SECTION 36 AS SHOWN HEREON.
- IT IS APPARENT THAT SOME PORTIONS OF THIS PARCEL ARE IN ZONE "A" AND MAY BE SUBJECT TO FLOODING. HOWEVER, NO BASE FLOOD ELEVATION HAS BEEN DETERMINED FOR ZONE "A". SOME PORTIONS OF THIS PARCEL ARE IN ZONE "X" AND ARE DETERMINED TO BE OUTSIDE THE 500 YEAR FLOOD PLAIN AS PER FLOOD INSURANCE RATE MAP, DATED 4 FEBRUARY, 2009 FIRM PANEL NO. 12023C0405C, HOWEVER, THE FLOOD INSURANCE RATE MAPS ARE SUBJECT TO CHANGE.
- THE IMPROVEMENTS, IF ANY, INDICATED ON THIS SURVEY DRAWING ARE AS LOCATED ON DATE OF FIELD SURVEY AS SHOWN HEREON.
- IF THEY EXIST, NO UNDERGROUND ENCROACHMENTS AND/OR UTILITIES WERE LOCATED FOR THIS SURVEY EXCEPT AS SHOWN HEREON.
- THIS SURVEY WAS COMPLETED WITHOUT THE BENEFIT OF A TITLE COMMITMENT OR A TITLE POLICY.
- DIMENSIONS SHOWN HEREON ARE IN FEET AND DECIMAL PARTS THEREOF.
- THIS SURVEY DOES NOT REFLECT OR DETERMINE OWNERSHIP.
- THE ADJACENT OWNERSHIP INFORMATION AS SHOWN HEREON IS BASED ON THE COUNTY PROPERTY APPRAISERS GIS SYSTEM, UNLESS OTHERWISE DENOTED.
- ACCESS WILL BE THROUGH ADJACENT OWNERSHIP.

BOUNDARY SURVEY IN SECTION 36 , TOWNSHIP 4 SOUTH, RANGE 17 EAST, COLUMBIA COUNTY, FLORIDA.

SYMBOL LEGEND:

- 4"x4" CONCRETE MONUMENT FOUND
- 4"x4" CONCRETE MONUMENT SET
- IRON PIPE FOUND
- IRON PIN AND CAP SET
- × "X" CUT IN PAVEMENT
- + CALCULATED PROPERTY CORNER
- ⊙ NAIL & DISK
- ⊕ POWER POLE
- + SIGN POST
- ▲ WATER METER
- ⊙ UTILITY BOX
- * WELL
- ⊕ SANITARY MANHOLE
- ⊖ CENTERLINE
- SECTION LINE
- ELECTRIC LINES
- WIRE FENCE
- CHAIN LINK FENCE
- WOODEN FENCE
- (PLAT) AS PER A PLAT OF RECORD
- (DEED) AS PER A DEED OF RECORD
- (CALC.) AS PER CALCULATIONS
- (FIELD) AS PER FIELD MEASUREMENTS
- P.R.M. PERMANENT REFERENCE MARKER
- P.C.P. PERMANENT CONTRL POINT

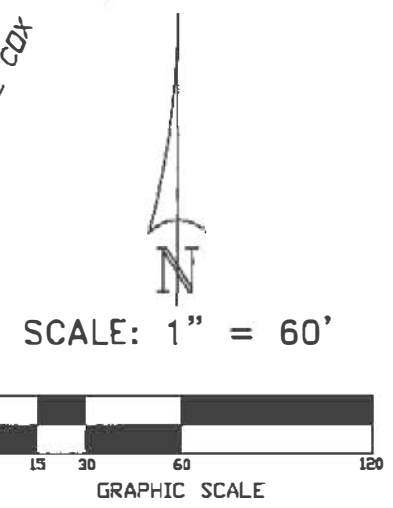
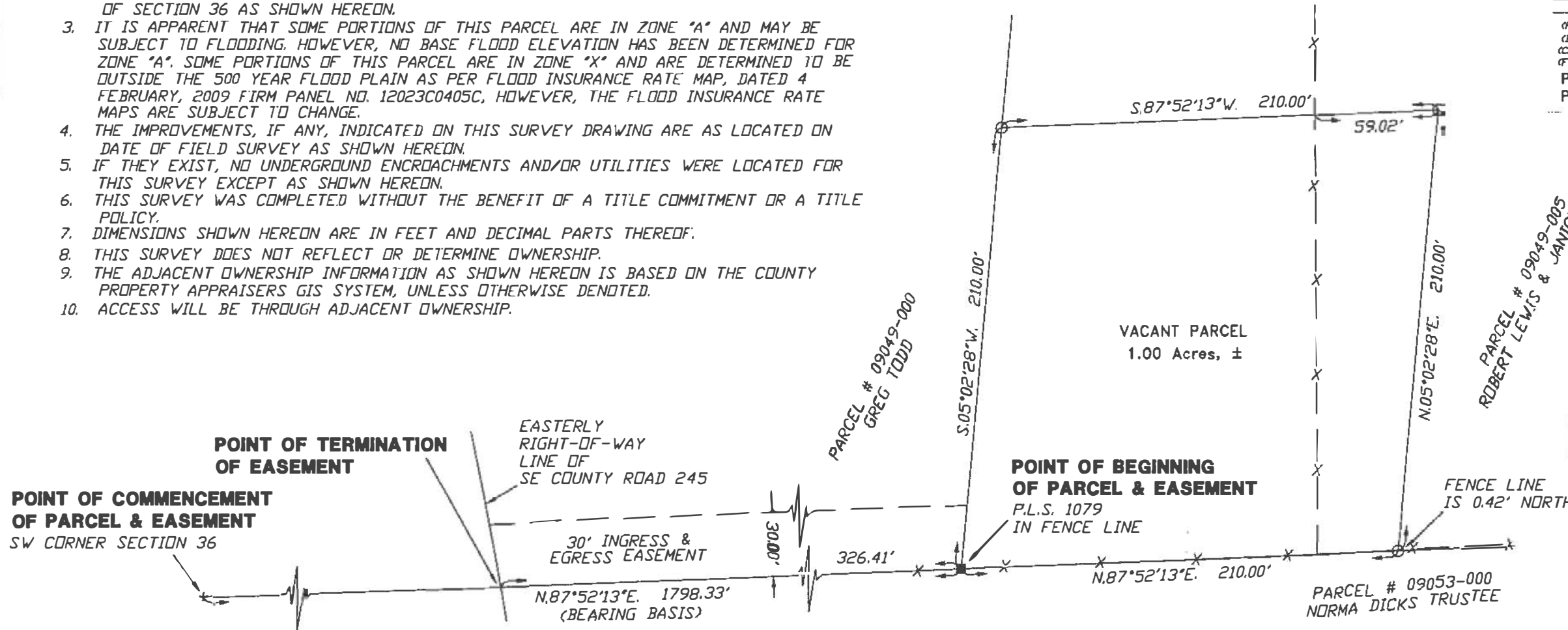

CERTIFIED TO:

CATHERINE & GREG TODD

SURVEYOR'S CERTIFICATION

I HEREBY CERTIFY THAT THIS SURVEY WAS MADE UNDER MY RESPONSIBLE CHARGE AND MEETS THE MINIMUM TECHNICAL STANDARDS AS SET FORTH BY THE FLORIDA BOARD OF PROFESSIONAL SURVEYORS AND MAPPERS IN CHAPTER 5J-17, FLORIDA ADMINISTRATIVE CODE, PURSUANT TO SECTION 472027, FLORIDA STATUTES.

2/26/19 03/08/19
 FIELD SURVEY DATE DRAWING DATE

Scott Britt
 E. SCOTT BRITT, P.S.M.
 CERTIFICATION # 5757

NOTE: UNLESS IT BEARS THE ORIGINAL SIGNATURE AND THE ORIGINAL RAISED SEAL OF A FLORIDA LICENSED SURVEYOR AND MAPPER THIS DRAWING, SKETCH, PLAT OR MAP IS FOR INFORMATIONAL PURPOSES ONLY AND IS NOT VALID.



BRITT SURVEYING & MAPPING, LLC

LAND SURVEYORS AND MAPPERS, L.B. # 8016
 2086 SW MAIN BLVD, SUITE 112, LAKE CITY, FLORIDA 32025
 (386)752-7163 FAX (386)752-5573
 www.brittsurvey.com

WORK ORDER # L- 25633

FIELD BOOK: SEE _____ PAGE(S): _____ FILE _____



**COLUMBIA COUNTY BOARD OF COUNTY COMMISSIONERS
AGENDA ITEM REQUEST FORM**

The Board of County Commissioners meets the 1st and 3rd Thursday of each month at 5:30 p.m. in the Columbia County School Board Administrative Complex Auditorium, 372 West Duval Street, Lake City, Florida 32055. All agenda items are due in the Board's office one week prior to the meeting date.

Today's Date: 3/14/2019 **Meeting Date:** 3/21/2019

Name: Danielle Beard **Department:** Clerk To Board Finance

Division Manager's Signature: 

1. Nature and purpose of agenda item:

This item requests Board approval for the payment of bills and vouchers in the amount of \$1,302,852.45 submitted March 6, 2019. All funds authorized for the issuance of these checks have been budgeted. The Clerk to Board office reviews bills and vouchers submitted for approval. If for any reason, any of these bills are not recommended for approval, the Clerk to Board office will notify the Board. Copies of invoices and supporting documentation are maintained in the Clerk to Board office for review.

2. Recommended Motion/Action:

Approve payment of bills and vouchers in the amount of \$1,302,852.45 submitted March 6, 2019.

3. Fiscal impact on current budget.

This item is currently budgeted. The account number to be charged is various

CHECK NUMBER	VENDOR NUMBER	SEQ#	VENDOR NAME	CHECK DATE	CHECK AMOUNT	DISCOUNTS/RETAINAGE TAKEN
28058	2013	00	A T & T	03/06/2019	2,358.03	.00
28059	3069	00	A T & T	03/06/2019	51.87	.00
28060	172	00	ABSTRACT & TITLE SERVICE	03/06/2019	18,000.00	.00
28061	185	00	ACTION SIGNS & GRAPHICS, INC.	03/06/2019	140.00	.00
28062	1207	00	ADVANCE AUTO PARTS	03/06/2019	82.50	.00
28063	1547	00	ADVANCED ENVIRONMENTAL LABORATORIES	03/06/2019	120.00	.00
28064	5231	00	ALDEN ROSNER	03/06/2019	5.97	.00
28065	3871	00	AMERICAN FAMILY FITNESS LAKE CITY	03/06/2019	75.00	.00
28066	111	00	ANDERSON COLUMBIA CO., INC.	03/06/2019	598,697.91	.00
28067	2985	00	APPLIED TECHNOLOGY AND MANAGEMENT	03/06/2019	35,196.75	.00
28068	3172	00	AT & T PRO CLUB	03/06/2019	812.27	.00
28069	3368	00	AT & T	03/06/2019	1,467.58	.00
28070	3637	00	AT & T PRO-CABS/IBS	03/06/2019	1,814.40	.00
28071	8195	00	AT&T	03/06/2019	26.25	.00
28072	3800	00	AV'S CUSTOM TRAILERS,LLC	03/06/2019	98.40	.00
28073	4995	00	AWESOME PRINTERS	03/06/2019	71.00	.00
28074	218	00	BAKER & TAYLOR BOOKS	03/06/2019	3,712.68	.00
28075	4015	00	BAYWAY SERVICE	03/06/2019	325.00	.00
28076	273	00	BCC - LANDFILL DEPOSIT	03/06/2019	83,659.26	.00
28077	3643	00	BEARD EQUIPMENT CO. INC.	03/06/2019	10,969.67	.00
28078	4746	00	BEAVER BULK, INC.	03/06/2019	21,919.43	.00
28079	250	00	BEST PLUMBING SPECIALTIES, INC.	03/06/2019	1,384.27	.00
28080	2733	00	BLOCK 60 HOLDINGS, LLC	03/06/2019	2,671.52	.00
28081	4680	00	BLUE SUMMIT WATERS, LLC	03/06/2019	25.75	.00
28082	3893	00	BOONE IMPROVEMENTS INC.	03/06/2019	4,877.41	.00
28083	3914	00	BRENT HAYDEN, M.D. P.A.	03/06/2019	530.00	.00
28084	10022	00	BSN SPORTS	03/06/2019	331.18	.00
28085	268	00	BUREAU OF FIRE STANDARDS & TRAINING	03/06/2019	404.20	.00
28086	8080	00	CAL-TECH TESTINGS, INC.	03/06/2019	2,615.00	.00
28087	1796	00	CAROLYN HEIGHTS WATER CO., INC.	03/06/2019	129.03	.00
28088	4818	00	CARREE O. MUSGROVE	03/06/2019	566.04	.00
28089	8675	00	CARROT-TOP IND.	03/06/2019	149.85	.00
28090	348	00	CENTRAL STATES ENTERPRISE, INC.	03/06/2019	79.58	.00
28091	3984	00	CERTIFIED LABRATORIES	03/06/2019	441.60	.00
28092	4334	00	CHAD WILLIAMS	03/06/2019	736.93	.00
28093	8097	00	CHAMBER OF COMMERCE	03/06/2019	500.00	.00
28094	2501	00	CINTAS CORPORATION #148	03/06/2019	2,641.96	.00
28095	382	00	CITY ELECTRIC SUPPLY, INC.	03/06/2019	482.01	.00
28096	304	00	CITY OF LAKE CITY - UTILITIES	03/06/2019	3,060.51	.00
28097	308	00	CLAY ELECTRIC COOPERATIVE, INC.	03/06/2019	880.70	.00
28098	352	00	CLERK OF COURT COLUMBIA COUNTY	03/06/2019	248.00	.00
28099	4273	00	COLLINSON AND COMPANY, INC	03/06/2019	2,000.00	.00
28100	317	00	COMBS FUNERAL HOME	03/06/2019	425.00	.00
28101	2822	00	COMCAST	03/06/2019	1,073.78	.00
28102	353	00	COMCAST BUSINESS	03/06/2019	7,360.91	.00
28103	4830	00	COMCAST CABLE COMMUNICATIONS, INC.	03/06/2019	133.76	.00
28104	5363	00	CONSULTANT CONNECT	03/06/2019	6,000.00	.00
28105	4816	00	CORBETTS MOBILE HOME SUPPLY	03/06/2019	29.45	.00
28106	3614	00	CO2 DIRECT GAS, INC.	03/06/2019	189.52	.00
28107	4846	00	CREATIVE CONCRETE DESIGN	03/06/2019	1,470.00	.00
28108	5241	00	D&DWA LAKE CITY LLC	03/06/2019	74.90	.00

CHECK NUMBER	VENDOR NUMBER	SEQ#	VENDOR NAME	CHECK DATE	CHECK AMOUNT	DISCOUNTS/RETAINAGE TAKEN
28109	4684	00	DAIKIN APPLIED	03/06/2019	7,787.26	.00
28110	5259	00	DALE STADLER	03/06/2019	35.60	.00
28111	1588	00	DEES-PARRISH FAMILY FUNERAL HOME	03/06/2019	450.00	.00
28112	415	00	DEMCO, INC	03/06/2019	362.56	.00
28113	977	00	DISH NETWORK,LLC	03/06/2019	294.93	.00
28114	1256	00	DONALD F. LEE & ASSOC, INC.	03/06/2019	12,727.75	.00
28115	4422	00	DR. JOHN WELLS JR.	03/06/2019	350.00	.00
28116	615	00	DUKE ENERGY	03/06/2019	28.46	.00
28117	432	00	E. VERNON DOUGLAS	03/06/2019	2,000.00	.00
28118	5372	00	ELENCO ELECTRONICS, INC.	03/06/2019	61.75	.00
28119	5370	00	F. D. SIGNWORKS, LLC	03/06/2019	629.58	.00
28120	1156	00	FASTENAL	03/06/2019	62.10	.00
28121	1986	00	FAUL EQUIPMENT SALES	03/06/2019	52.00	.00
28122	844	00	FERGUSON ENTERPRISES INC	03/06/2019	5,261.00	.00
28123	3822	00	FERGUSON ENTERPRISES INC #52	03/06/2019	533.90	.00
28124	649	00	FLORIDA ASSOC. OF CO., TRUST	03/06/2019	1,620.82	.00
28125	1226	00	FLORIDA GATEWAY COLLEGE	03/06/2019	300.00	.00
28126	639	00	FLORIDA IRRIGATION SUPPLY	03/06/2019	780.00	.00
28127	642	00	FLORIDA PEST CONTROL	03/06/2019	2,749.00	.00
28128	613	00	FLORIDA POWER & LIGHT	03/06/2019	339.99	.00
28129	625	00	FLORIDA TIMES UNION	03/06/2019	737.89	.00
28130	4154	00	FORT WHITE TRUE VALUE HARDWARE	03/06/2019	33.62	.00
28131	3140	00	FUTURE FITNESS	03/06/2019	45.00	.00
28132	806	00	G.W. HUNTER, INC.	03/06/2019	17,069.43	.00
28133	1860	00	GALE/CENGAGE LEARNING	03/06/2019	16.89	.00
28134	702	00	GALLS, LLC	03/06/2019	87.11	.00
28135	719	00	GAMETIME	03/06/2019	201.84	.00
28136	759	00	GATEWAY-FOREST LAWN FUNERAL HOME, IN	03/06/2019	450.00	.00
28137	762	00	GENESIS DOOR & HARDWARE, INC.	03/06/2019	1,060.18	.00
28138	4573	00	GLENN HUNTER	03/06/2019	42.50	.00
28139	732	00	GLOBAL EQUIPMENT	03/06/2019	329.94	.00
28140	754	00	GRAHAM & SONS ELECTRICAL, INC.	03/06/2019	1,975.59	.00
28141	724	00	GRAINGER	03/06/2019	617.44	.00
28142	745	00	GREAT AMERICA FINANCIAL SVCS	03/06/2019	424.79	.00
28143	794	00	GREEN'S MARINE & SPORTING GOODS	03/06/2019	935.02	.00
28144	3000	00	GREG TODD	03/06/2019	234.87	.00
28145	5115	00	GUARDIAN FUELING TECHNOLOGIES, LLC	03/06/2019	363.10	.00
28146	2416	00	HAIR HOME & AUTO CENTER, INC.	03/06/2019	184.91	.00
28147	819	00	HAL A. AIRTH	03/06/2019	18,000.00	.00
28148	857	00	HALL-MARK RTC	03/06/2019	1,909.66	.00
28149	4804	00	HAWKINS, INC.	03/06/2019	98.00	.00
28150	818	00	HILL MANUFACTURING CO., INC.	03/06/2019	176.00	.00
28151	826	00	HO BO TRACTOR CO., INC.	03/06/2019	33.64	.00
28152	896	00	HOBART SERVICE	03/06/2019	1,792.08	.00
28153	2133	00	HOME DEPOT CREDIT SERVICE/THE	03/06/2019	486.34	.00
28154	4132	00	ICHETUCKNEE PARTNERSHIP	03/06/2019	40,000.00	.00
28155	3547	00	IEDC	03/06/2019	435.00	.00
28156	5367	00	IMMAC POWER SOLUTIONS INC.	03/06/2019	920.00	.00
28157	942	00	INTEGRITY TITLE SERVICE,LLC	03/06/2019	12,000.00	.00
28158	911	00	INTERSTATE SUPPLY	03/06/2019	204.98	.00
28159	1025	00	JACKSONVILLE SOUND & COMM.,INC.	03/06/2019	3,800.00	.00

CHECK NUMBER	VENDOR NUMBER	SEQ#	VENDOR NAME	CHECK DATE	CHECK AMOUNT	DISCOUNTS/RETAINAGE TAKEN
28160	1009	00	JENKIN'S PAINTING, INC.	03/06/2019	8,277.68	.00
28161	1680	00	JOHN'S LAWN EQUIPMENT, INC.	03/06/2019	343.82	.00
28162	4322	00	KAIL PARTNERS, LLC	03/06/2019	6,500.00	.00
28163	548	00	KATRINA EVANS	03/06/2019	103.29	.00
28164	1102	00	KEATON LOCKSMITHS	03/06/2019	77.97	.00
28165	5376	00	KENNETH J. SULAK	03/06/2019	100.00	.00
28166	1131	00	KENT ADHESIVE PROD. CO.	03/06/2019	97.50	.00
28167	1968	00	KIMI ROBERTS	03/06/2019	8.45	.00
28168	1254	00	LAINÉ INDUSTRIES, INC.	03/06/2019	206.60	.00
28169	5026	00	LAKE AND WETLAND MAMAGEMENT	03/06/2019	527.00	.00
28170	1212	00	LAKE CITY AUTO PARTS	03/06/2019	969.11	.00
28171	1224	00	LAKE CITY HUMANE SOCIETY, INC.	03/06/2019	27,916.66	.00
28172	1230	00	LAKE CITY INDUSTRIES	03/06/2019	7.98	.00
28173	1241	00	LAKE CITY REPORTER	03/06/2019	83.00	.00
28174	1204	00	LAKE CITY REPORTER, INC.	03/06/2019	83.00	.00
28175	3020	00	LEVY JONES	03/06/2019	107.80	.00
28176	4290	00	LKQ NORTH FLORIDA	03/06/2019	1,264.00	.00
28177	1262	00	LOWE'S PROX	03/06/2019	759.60	.00
28178	1216	00	LUBE SPECIALISTS	03/06/2019	611.23	.00
28179	4504	00	MADDEN MEDIA	03/06/2019	2,208.33	.00
28180	4621	00	MAILFINANCE	03/06/2019	678.00	.00
28181	118	00	MATHESON TRI-GAS INC.	03/06/2019	61.98	.00
28182	1341	00	MATT CREWS	03/06/2019	61.00	.00
28183	1319	00	MCCRIMON'S OFFICE SUPPLY	03/06/2019	472.18	.00
28184	1351	00	METAL MASTERS OF FLORIDA INC.	03/06/2019	343.50	.00
28185	4503	00	METZ,HUSBAND& DAUGHTON,P.A.	03/06/2019	6,700.00	.00
28186	1329	00	MIDWEST TAPE EXCHANGE	03/06/2019	50.38	.00
28187	1357	00	MILES PARTNERSHIP, LLP	03/06/2019	1,383.00	.00
28188	1347	00	MINI-STORAGE/RECORD STORAGE OF	03/06/2019	48.50	.00
28189	812	00	MOTION INDUSTRIES, INC.	03/06/2019	155.86	.00
28190	4942	00	MUNICIPAL EMERGENCY SERVICES, INC.	03/06/2019	404.00	.00
28191	1434	00	NE-RO TIRE & BRAKE SERVICE	03/06/2019	3,226.25	.00
28192	1429	00	NEXTRAN TRUCK CENTER	03/06/2019	105.99	.00
28193	1194	00	NFPA	03/06/2019	1,575.00	.00
28194	1439	00	NORTH FLORIDA FENCE	03/06/2019	650.00	.00
28195	3663	00	NORTH FLORIDA PROFESSIONAL SERVICES	03/06/2019	15,906.00	.00
28196	1622	00	OFFICE DEPOT	03/06/2019	1,947.66	.00
28197	5102	00	OVERDRIVE, INC.	03/06/2019	871.90	.00
28198	310	00	P.DEWITT CASON CLERK OF COURT	03/06/2019	35,220.00	.00
28199	4956	00	PARADISE PLUMBING SERVICES, LLC	03/06/2019	535.00	.00
28200	3597	00	PATRICK'S UNIFORMS OF FLORIDA, INC.	03/06/2019	94.31	.00
28201	1707	00	PELONI'S PUMPING	03/06/2019	265.00	.00
28202	1041	00	PETE OLIN AUTO PARTS, INC.	03/06/2019	471.26	.00
28203	4566	00	PETTYS ASPHALT	03/06/2019	2,025.00	.00
28204	2314	00	POWER SECURE SERVICE, INC.	03/06/2019	1,554.02	.00
28205	5344	00	PREFORM LLC	03/06/2019	1,822.50	.00
28206	4063	00	PREMIER PAPER & JANITORIAL SUPPLIES	03/06/2019	1,435.31	.00
28207	1766	00	PRIDE ENTERPRISES	03/06/2019	1,011.98	.00
28208	4345	00	PRITCHETT TRUCKING, INC.	03/06/2019	1,079.33	.00
28209	1788	00	PRO-CHEM, INC.	03/06/2019	136.26	.00
28210	1763	00	PUBLIC DEFENDER	03/06/2019	699.00	.00

CHECK NUMBER	VENDOR NUMBER	SEQ#	VENDOR NAME	CHECK DATE	CHECK AMOUNT	DISCOUNTS/RETAINAGE TAKEN
28211	1175	00	PUBLIC DEFENDER I.T.	03/06/2019	1,864.00	.00
28212	1812	00	QUALITY EQUIPMENT & PARTS, INC.	03/06/2019	27.58	.00
28213	4555	00	QUEST LINER	03/06/2019	7,922.11	.00
28214	1935	00	RADIAN SETTLEMENT SERVICE	03/06/2019	12,000.00	.00
28215	1183	00	RELIABLE SHREDDING SERVICE	03/06/2019	75.00	.00
28216	10035	00	REP SERVICES	03/06/2019	3,386.58	.00
28217	4171	00	RICHARDSON C/C ANNIE MATTOX PARK N.	03/06/2019	2,121.88	.00
28218	3415	00	RICHARDSON PAINT	03/06/2019	614.91	.00
28219	4644	00	RICKY RESCUE TRAINING ACADEMY	03/06/2019	450.00	.00
28220	1907	00	RING POWER CORP.	03/06/2019	5,694.78	.00
28221	2960	00	ROBERT L. BOSTIC	03/06/2019	1,050.00	.00
28222	1906	00	ROUNTREE-MOORE CHEVROLET	03/06/2019	662.08	.00
28223	1911	00	ROUNTREE-MOORE FORD	03/06/2019	1,201.26	.00
28224	5073	00	RUSSELL'S WESTERN WEAR, INC.	03/06/2019	89.99	.00
28225	2053	00	SAWYER HOME GAS, INC.	03/06/2019	563.40	.00
28226	1189	00	SHANE OVERSTREET	03/06/2019	234.87	.00
28227	2764	00	SHAWN HENDERSON	03/06/2019	234.87	.00
28228	2021	00	SHERWIN-WILLIAMS CO.STORE#2741	03/06/2019	32.28	.00
28229	5061	00	SMARTCOP	03/06/2019	2,500.00	.00
28230	3056	00	SOUTHEASTERN TURFGRASS SUPPLY, INC.	03/06/2019	27,048.00	.00
28231	287	00	SOUTHERN SPECIALIZED LLC	03/06/2019	2,415.89	.00
28232	5369	00	SPHERO, INC.	03/06/2019	49.97	.00
28233	5304	00	SPORTS DESTINATION MANAGEMENT	03/06/2019	3,000.00	.00
28234	5284	00	SPORTS FACILITIES ADVISROY, LLC	03/06/2019	883.16	.00
28235	2805	00	STANLEY CONVERGENT SECURITY SOLUTI	03/06/2019	331.20	.00
28236	3610	00	STANLEY CRAWFORD	03/06/2019	3,284.00	.00
28237	1198	00	STATE ATTORNEY'S OFFICE (IT)	03/06/2019	3,590.87	.00
28238	2022	00	STATE ATTORNEY'S OFFICE-F	03/06/2019	2,612.81	.00
28239	4857	00	STRICTLY TECHNOLOGY LLC	03/06/2019	511.95	.00
28240	5142	00	SUMMERVILLE SYSTEMS	03/06/2019	6,094.74	.00
28241	4888	00	SUN PROFESSIONAL SUPPLY, LLC	03/06/2019	50.88	.00
28242	814	00	SUPERION, LLC A CENTRAL SQUARE CO.	03/06/2019	2,750.39	.00
28243	2087	00	SUPERVISOR OF ELECTIONS	03/06/2019	55,889.30	.00
28244	8074	00	SUWANNEE RIVER SUPPLY	03/06/2019	108.00	.00
28245	2028	00	SUWANNEE VALLEY ELECT. CO.	03/06/2019	2,758.04	.00
28246	2018	00	SUWANNEE VALLEY 4 C'S	03/06/2019	2,500.00	.00
28247	2078	00	SWIFT LUBE	03/06/2019	117.82	.00
28248	4661	00	SYNOVIA SOLUTIONS LLC	03/06/2019	677.76	.00
28249	3848	00	TARGETSOLUTIONS, INC.	03/06/2019	5,891.00	.00
28250	2163	00	TEEKO GRAPHICS	03/06/2019	116.00	.00
28251	2147	00	TEN-8 FIRE EQUIPMENT INC.	03/06/2019	2,994.15	.00
28252	4288	00	THE FOUNDATION FOR FLA,GATEWAY COLL	03/06/2019	1,750.00	.00
28253	2220	00	THE STORE	03/06/2019	1,074.89	.00
28254	4364	00	THOMAS BRAZIL	03/06/2019	61.00	.00
28255	2176	00	THOMAS HARDWARE FARM & LUMBER, INC.	03/06/2019	26.99	.00
28256	2117	00	THOMAS TIRE INC.	03/06/2019	558.10	.00
28257	1458	00	TOM NEHL TRUCK COMPANY	03/06/2019	116.04	.00
28258	4672	00	TOTALFUNDS	03/06/2019	4,000.00	.00
28259	4442	00	TOWER ENGINEERING PROFESSIONALS INC	03/06/2019	3,700.00	.00
28260	5157	00	TWO FOLD WATER ENGINEERING, INC.	03/06/2019	1,880.00	.00
28261	2718	00	U.S. LOCK	03/06/2019	748.70	.00

PREPARED 3/06/2019, 7:03:10
 PROGRAM: GM348U
 COLUMBIA COUNTY
 BANK 00 BOARD OF COUNTY COMM - CLAIMS TD BANK

ACCOUNTS PAYABLE PRELIMINARY CHECK REGISTER

CHECK NUMBER	VENDOR NUMBER	SEQ#	VENDOR NAME	CHECK DATE	CHECK AMOUNT	DISCOUNTS/RETAINAGE TAKEN
28262	4909	00	UNITED REFRIGERATION, INC.	03/06/2019	1,320.00	.00
28263	4922	00	UNIVERSAL ENVIRONMENTAL SERVICES	03/06/2019	110.00	.00
28264	2673	00	VERIZON WIRELESS	03/06/2019	4,242.24	.00
28265	3050	00	VOICE FOR CHILDREN	03/06/2019	1,471.60	.00
28266	4458	00	WASTE UNIVERSITY	03/06/2019	538.00	.00
28267	2462	00	WHITEHEAD HARDWARE COMPANY	03/06/2019	532.01	.00
28268	129	00	WINDSTREAM	03/06/2019	723.71	.00
28269	5190	00	WINSUPPLY	03/06/2019	503.34	.00
28270	559	00	WORK FORCE QA	03/06/2019	396.25	.00
28271	4712	00	WORXTIME LLC	03/06/2019	730.00	.00
28272	2404	00	WSMDD LAND TRUST	03/06/2019	16,524.99	.00
28273	2500	00	XEROX CORP	03/06/2019	1,868.00	.00
28274	3551	00	ZEP SALES & SERVICE	03/06/2019	474.78	.00
28275	5166	00	ZOLL MEDICAL CORP	03/06/2019	708.75	.00
28276	5217	00	4IMPRINT, INC.	03/06/2019	939.00	.00
NUMBER OF CHECKS			219	GRAND TOTAL	1,302,852.45	



COLUMBIA COUNTY BOARD OF COUNTY COMMISSIONERS
AGENDA ITEM REQUEST FORM

The Board of County Commissioners meets the 1st and 3rd Thursday of each month at 5:30 p.m. in the Columbia County School Board Administrative Complex Auditorium, 372 West Duval Street, Lake City, Florida 32055. All agenda items are due in the Board's office one week prior to the meeting date.

Today's Date: 3/1/2019 Meeting Date: 3/21/2019

Name: Shayne Morgan Department: Hmgrp

Division Manager's Signature: [Handwritten Signature]

1. Nature and purpose of agenda item:

BA 19-39--Approve BA to pay final invoices on TS Debby and Hurricane Irma HMGP.

2. Recommended Motion/Action:

Motion to Approve BA 19-39

3. Fiscal impact on current budget.

This item is not budgeted. The proposed budget amendment to fund this request is provided below. The budget amemdment number is BA 19-39 using fund(s) 001-GENERAL FUND.

Table with 3 columns: FROM, TO, AMOUNT. It details budget amendments from 001-8400-584.90-99 to 001-2115-252.30-34 and 001-2122-525.30-31, with amounts of \$6,100.00 and \$2,299.00.

District No. 1 - Ronald Williams
District No. 2 - Rocky Ford
District No. 3 - Bucky Nash
District No. 4 - Toby Witt
District No. 5 - Tim Murphy



BOARD OF COUNTY COMMISSIONERS • COLUMBIA COUNTY

MEMORANDUM

TO: Columbia County Board of County Commissioners
FR: David Kraus, Assistant County Manager
DATE: March 1, 2019
RE: BA 19-39 - HMGP–TS Debby Closeout and HMGP – Irma Application

After Tropical Storm Debby, the County received 3 Hazard Mitigation Program (HMGP) Grants from the Federal Emergency Management Agency through the State of Florida. These three grants were completed in the previous fiscal year and closeout documents filed with the State Division of Emergency Management. While we are waiting on the approval of the closeout and final payment for the grants, we discovered one invoice to Arcadis that remains unpaid.

The County has also applied for HMGP funding from Hurricane Irma. As with HMGP grants, the application preparation can be paid by the grant as a pre-award cost. The County must expend the funds first, and then would be reimbursed if the grant is awarded. North Florida Professional Services prepared and submitted the grant application. One final invoice for \$2,299 is outstanding for the period covering responding to FEMA’s additional requests for information. We anticipate HMGP funding in the fall.

Staff is requesting the Columbia County Board of County Commissioners to approve the attached Budget Amendment (BA 19-39) for \$8,399 for the final payment on the HMGP-TS Debby projects (\$6,100) and the final payment on HMGP-Irma application (\$2,299).

BOARD MEETS FIRST AND THIRD THURSDAY AT 5:30 P.M.



**COLUMBIA COUNTY BOARD OF COUNTY COMMISSIONERS
AGENDA ITEM REQUEST FORM**

The Board of County Commissioners meets the 1st and 3rd Thursday of each month at 5:30 p.m. in the Columbia County School Board Administrative Complex Auditorium, 372 West Duval Street, Lake City, Florida 32055. All agenda items are due in the Board's office one week prior to the meeting date.

Today's Date: 3/14/2019 Meeting Date: 3/21/2019

Name: Shayne Morgan Department: Emergency Management

Division Manager's Signature: 

1. Nature and purpose of agenda item:

This agreement will lead to reimbursement of funds that were expended during Hurricane Irma in 2017. Debris removal, repair of washed out roads, and emergency protective measures are among the items that are being reimbursed here.

2. Recommended Motion/Action:

I recommend the approval of this agreement to get reimbursed on eligible expenses from Hurricane Irma.

3. Fiscal impact on current budget.

This item has no effect on the current budget.

**MODIFICATION # Z0618 TO SUBGRANT AGREEMENT
BETWEEN THE DIVISION OF EMERGENCY
MANAGEMENT AND
Columbia County**

This Modification is made and entered into by and between the State of Florida, Division of Emergency Management ("the Division"), and Columbia County ("Sub-Recipient"), to modify Contract Number Z0618, which began on 9/04/2017 ("the Agreement").

WHEREAS, the Division and the Sub-Recipient have entered into the Agreement, pursuant to which the Division has provided a Subgrant to Sub-Recipient under the public assistance program of \$265,000.48 in funds; and,

WHEREAS, the Division and Sub-Recipient desire to modify the Agreement by increasing the Federal funding \$251,761.75 under the Agreement.

WHEREAS, the Division and the Sub-Recipient desire to modify the Scope of Work.

WHEREFORE, in consideration of the mutual promises of the parties contained herein, the parties agree as follows:

1. The Agreement is hereby amended to increase the Federal funding by \$251,761.75 and the State share by \$28,340.85 for the maximum amount payable under the Agreement to \$545,103.08.
2. The Scope of Work, Attachment A to the Agreement, is hereby modified as set forth in the 3rd Revised Attachment A to this Modification, a copy of which is attached hereto and incorporated herein by reference.
3. All provisions of the Agreement being modified and any attachments thereto in conflict with this Modification shall be and are hereby changed to conform with this Modification, effective as of the date of the last execution of this Modification by both parties.
4. All provisions not in conflict with this Modification remain in full force and effect, and are to be performed at the level specified in the Agreement.

IN WITNESS WHEREOF, the parties hereto have executed this Modification as of the dates set out below.

SUB-RECIPIENT: _____ Columbia County _____

By: _____

Name and Title: _____

Date: _____

DIVISION OF EMERGENCY MANAGEMENT

By: _____

Name and Title: **Jared Moskowitz, Director**

Date: _____

Attachment A - 3rd Revision

Budget and Project List

Budget:

The Budget of this Agreement is initially determined by the amount of any Project Worksheet(s) (PW) that the Federal Emergency Management Administration (FEMA) has obligated for a Sub-Recipient at the time of execution. Subsequent PWs or revisions thereof will increase or decrease the Budget of this Agreement. The PW(s) that have been obligated are:

DR-433		Sub-Recipient: Columbia County									
PW #	Cat	Project Title	Federal Share	Fed%	State Share	State %	Local Share	Local %	Total Eligible Amount	POP Start Date	POP End Date
160	C	Repair washout on county roads	\$219,777.44	50%	\$36,629.58	12.5%	\$36,629.58	12.5%	\$293,036.59	9/01/2017	3/10/2019
398	A	Phase III debris removal	\$5,373.86	80%	\$671.73	100%	\$671.73	100%	\$6,717.31	9/01/2017	3/10/2018
407	A	Countywide debris removal Sept 4 to Sept 17	\$73,960.07	50%	\$15,660.01	12.5%	\$15,660.01	12.5%	\$125,280.12	9/01/2017	3/10/2018
408	A	Phase II debris removal	\$122,570.79	90%	\$6,807.73	50%	\$6,807.72	50%	\$135,194.52	9/01/2017	3/10/2018
420	B	Emergency Protective Measures - Oct 4 to Oct 18	\$2,183.90	50%	\$363.98	12.5%	\$363.98	12.5%	\$2,911.86	9/01/2017	3/10/2018
450	B	School System Sheltering Costs	\$3,226.57	50%	\$587.10	12.5%	\$587.10	12.5%	\$4,966.79	9/01/2017	3/10/2018
Total:			\$479,069.1		\$66,006.14		\$66,006.11		\$611,102.19		



**COLUMBIA COUNTY BOARD OF COUNTY COMMISSIONERS
AGENDA ITEM REQUEST FORM**

The Board of County Commissioners meets the 1st and 3rd Thursday of each month at 5:30 p.m. in the Columbia County School Board Administrative Complex Auditorium, 372 West Duval Street, Lake City, Florida 32055. All agenda items are due in the Board's office one week prior to the meeting date.

Today's Date: 3/11/2019 Meeting Date: 3/21/2019

Name: Jeff Crawford Department: Fire Department

Division Manager's Signature:

1. Nature and purpose of agenda item:

Purchase asset and inventory tracking and management program

2. Recommended Motion/Action:

Approval of new inventory and asset tracking software

3. Fiscal impact on current budget.

This item is currently budgeted. The account number to be charged is 102-2200-522.30-64



Fire Chief
Jeffery Crawford

COLUMBIA COUNTY FIRE RESCUE

509 SW Bascom Norris Dr., Lake City, FL 32025

Office (386) 754-7057 Fax (386) 754-7064

MEMORANDUM

DATE: March 11, 2019

TO: Ben Scott

FR: Jeff Crawford

RE: Fire Department Asset Tracking

Silent Partner Technologies supplies RFID asset tracking and inventory management systems specific for Fire & EMS departments. The RFID tags are specifically made to withstand the heat and rigors of firefighting equipment. The Intelliview software has been developed to meet the inventory needs of Fire & EMS supplies & assets. This system will save time and money by giving us the ability to track accurately track the movement of inventory within our department. The starter kit is \$3,120 which includes the RFID reader, 50 tags, and 1 year of Intelliview software subscription. The annual price for the software is \$1,125 for up to 2 RFID readers.



CompData Systems

P.O Box 341513
TAMPA, FL. 33694
PH: (813) 906-7662

NAME: Ms. Sandra Davis
COMPANY: Columbia County Fire Rescue
ADDRESS:

Date: 2/21/2019

CONFIDENTIAL AND BASED ON VOLUME PRICING

PHONE:
FAX:
EMAIL:

QUOTE:
QUOTE VALID FOR: 2 Weeks

PAYMENT TERMS	SHIP VIA	SALES CONSULTANT		DELIVERY	
50/30/20					
PART NUMBER	DESCRIPTION	QTY	UNIT	SELL PRICE	EXTENDED
	IntelliView Pricing--Passive, Active or Both. Solution Sold as a Service. Solution includes but not limited to Asset Management, Inventory Management, Service, Maps, and more. Pricing is on a "per reader license/per year" and "user licenses). Solution comes with 2 initial reader licenses and 3 user licenses.				
SPT-INT-01	1 to 2 Readers (\$1,125.00 for 1)	1	ea	1,125.00	1,125.00
SPT-INT-03	3 to 5	0	ea	3,250.00	-
SPT-INT-06	6 to 10	0	ea	4,995.00	-
SPT-INT-11	11 to 15	0	ea	5,650.00	-
SPT-INT-16	16 to 20 (\$.087 Cents per reader per day)	0	ea	6,250.00	-
SPT-INT-21	21 to 30	0	ea	7,500.00	-
SPT-INT-31	31 to 40	0	ea	8,750.00	-
SPT-INT-41	41 to 50	0	ea	9,750.00	-
	Annual Software License Passive or Active:	0	ea	1,125.00	-
	IntelliVan Per Vehicle Pricing/Per Year:	1	ea	2,195.00	2,195.00
	TSL UHF Bluetooth Device for Physical Counts, Includes One Time License and iPod--IF CLIENT PROVIDES DEVICE, Subtract \$200.	1	ea	(200.00)	(200.00)
	50 various RFID tags for Assets average price	1	ea	2.97	n/c
SERVICES					
SPT-SER-SRV	Professional Services including, Site Survey, Consulting, Discovery (specification requirements definition), installation, configuration, import and database services, on site, off site. Budgetary.				
SPT-TRAVEL					
	SEE SHEET 2 FOR ALL CONSUMABLES.				
	SEE SHEET 3 FOR ALL CONSUMABLES.				

***TERMS AND CONDITIONS <http://www.silentpartnertech.com/spt-terms-conditions/>
****UNLESS OTHERWISE NOTED SHIPPING AND HANDLING CHARGES ARE NOT INCLUDED IN ABOVE QUOTATION****

THANK YOU FOR YOUR BUSINESS

	SUBTOTAL	\$ 3,120.00
	SALES TAX	
	TOTAL	

CONDITIONS: The prices and terms on this quotation are not subject to verbal changes or other agreements unless approved in writing by The Home Office of the Seller. All Quotations and agreements are contingent upon strikes, accidents, fires, availability of materials and all other causes beyond our control. Prices are based on costs and conditions existing on date of quotation and are subject to change by the Seller before final acceptance.
Typographical and stenographic errors subject to correction. Purchaser agrees to accept either overage or shortage not in excess of ten percent to be charged pro rata. Purchaser assumes liability for patent and copyright infringement when goods are made to Purchaser's specifications. When quotation specifies material to be furnished by the purchaser, ample allowance must be made for reasonable spoilage and material must be of suitable quality to facilitate efficient production.
Conditions not specifically stated herein shall be governed by established trade customs. Terms inconsistent with those stated herein which may appear on Purchaser's formal order will not be binding on the Seller.

This document contains information which is proprietary to CompData Systems and may not be divulged to any third party with out the expressed written consent of CompData Systems.



COLUMBIA COUNTY BOARD OF COUNTY COMMISSIONERS AGENDA ITEM REQUEST FORM

The Board of County Commissioners meets the 1st and 3rd Thursday of each month at 5:30 p.m. in the Columbia County School Board Administrative Complex Auditorium, 372 West Duval Street, Lake City, Florida 32055. All agenda items are due in the Board's office one week prior to the meeting date.

Today's Date: 3/5/2019 Meeting Date: 3/21/2019

Name: Katrina Evans Department: Library

Division Manager's Signature: 

1. Nature and purpose of agenda item:

BA 19-40--This budget amendment is to distribute \$2554 donated by the Friends of the Library to the appropriate lines in the Library's budget.

2. Recommended Motion/Action:

Motion to accept donation and appropriate to the Library's budget.

3. Fiscal impact on current budget.

This item is not budgeted. The proposed budget amendment to fund this request is provided below.
The budget amendment number is BA 19-40 using fund(s) 104-LIBRARY ENHANCEMENT.

FROM:	TO:	AMOUNT:
104-0000-366.20-00 CONTRIBUTIONS & DONATIONS / CONTRIBUTIONS	104-7100-571.30-54 OPERATING EXPENDITURES / SUBSCRIPTIONS & DUES	\$1,004.00
104-0000-366.20-00 CONTRIBUTIONS & DONATIONS / CONTRIBUTIONS	104-7100-571.30-31 OPERATING EXPENDITURES / PROFESSIONAL SERVICES	\$1,550.00



DEPOSIT TICKET



DATE 3/5/19

DEPOSITS MAY NOT BE AVAILABLE FOR IMMEDIATE WITHDRAWAL

3855122
DS4 4-D-BK

	DOLLARS	CENTS
CURRENCY		
COIN		
CHECKS LIST EACH SEPARATELY		
1 Friends of		
2 CPL	2554	00
3		
4 104-0000-306-2000		
5 Children's Summer Reading Prog.		
6		
7		
8		
9		
10		
11		
12		
13		
14		
15		
16		
17		

COLUMBIA COUNTY BOARD OF COUNTY COMMISSIONERS

CLAIMS FUND/ LIBRARY

P.O. BOX 1529

LAKE CITY, FL 32056-1529

TOTAL ITEMS

1

\$

2554.00

PLEASE RE-ENTER TOTAL HERE

TOTAL 2554.00

CHECKS AND OTHER ITEMS ARE RECEIVED FOR DEPOSIT SUBJECT TO THE PROVISIONS OF THE UNIFORM COMMERCIAL CODE AND ANY APPLICABLE COLLECTION AGREEMENT.

Prepared By A. WOODY
Please Print

Verified By _____

⑈0000004⑈ ⑆5240⑈ ⑆0201⑆ 428252670⑈

Columbia County Public Library

11:21AM 03/05/19 *5701 COMMER DEP \$2,554.00 440

11:21AM 03/05/19 *5701 COMMER DEP \$2,554.00 440

LIBRARY DEPOSIT RECONCILIATION

DATE: 03/05/2019

By: A. Woody

	CASH/CHECK	CREDIT CARD (PAYGOV)	CASH REFUNDS	TOTAL
104-0000.366.2000 Children's Summer Reading Program	DONATION \$ 2,554.00			\$ 2,554.00
				\$ -
				\$ -
				\$ -
				\$ -
				\$ -
				\$ -
				\$ -
				\$ -
				\$ -
TOTAL BY PAYMENT TYPE	\$ 2,554.00	\$ -	\$ -	\$ 2,554.00



**COLUMBIA COUNTY BOARD OF COUNTY COMMISSIONERS
AGENDA ITEM REQUEST FORM**

The Board of County Commissioners meets the 1st and 3rd Thursday of each month at 5:30 p.m. in the Columbia County School Board Administrative Complex Auditorium, 372 West Duval Street, Lake City, Florida 32055. All agenda items are due in the Board's office one week prior to the meeting date.

Today's Date: 3/14/2019 Meeting Date: 3/21/2019

Name: Kevin Kirby Department: Public Works

Division Manager's Signature: 

1. Nature and purpose of agenda item:

Approve FDOT Lighting Contract for 2019/2020 in the amount of \$131,636.44.

2. Recommended Motion/Action:

Approve

3. Fiscal impact on current budget.

This item is currently budgeted. The account number to be charged is 101-0000-369.20-00

District No. 1 - Ronald Williams
District No. 2 - Rocky Ford
District No. 3 - Bucky Nash
District No. 4 - Toby Witt
District No. 5 - Tim Murphy



BOARD OF COUNTY COMMISSIONERS • COLUMBIA COUNTY

Memo

Date: March 15, 2019
To: Ben Scott, County Manager
From: Kevin Kirby, Assistant County Manager 
RE: 2019/2020 FDOT Lighting Contract

Attached please find the 2019/2020 Lighting Contract from FSOT. The reimbursement amount will be \$131,636.44 for 502 street lights. Please have the Board of County Commissioners approve and execute this contract.

Once I receive the executed contract the outage report will be attached and sent to FDOT.

If you should need to discuss further, please contact me.

BOARD MEETS FIRST AND THIRD THURSDAY AT 5:30 P.M.

P.O. BOX 1529

LAKE CITY, FLORIDA 32056-1529

PHONE (386) 755-4100



Florida Department of Transportation

RON DESANTIS
GOVERNOR

1109 South Marion Avenue
Lake City, Florida 32025-5874

KEVIN J. THIBAUT, P.E.
SECRETARY

March 12, 2019

Columbia County
Ben Scott, County Manager
P.O. Box 1529
Lake City, Florida 32056-1529

Contract: ANJ85
Fin Proj. No.: 41440617801
Description: State Highway Lighting Agreement
Renewal Period: July 1, 2019 thru June 30, 2020

Maintaining Agency:

The Department has reviewed the proposed prorated budget allocation for the upcoming fiscal year for the State Highway Lighting, Maintenance and Compensation program. The Department has determined the amount that you are currently eligible for under this program for the next year.

502 Street Lights x .9 x \$291.36 = \$131,636.44

The 90% multiplier used in the new formula shown in Exhibit B comes from paragraph 1.b. in your agreement which states that a minimum of 90% of the lights shall be operating and properly functioning.

Please sign and date: Exhibit "A" and return original signature and the Damage and Outage Report to:

**Florida Department of Transportation
District Maintenance Contracts Office – MS 2010
1109 South Marion Avenue
Lake City, Florida 32025-5874**

If the Department does not receive the Exhibit "A" fully executed and the Damage and Outage Report you will not be eligible for reimbursement of your cost for the period from July 1, 2019 to June 30, 2020. Return both documents on or before June 1, 2019.

REMINDER: FISCAL YEAR 2018/19 INVOICE MAY BE SUBMITTED ON OR AFTER MAY 19, 2019.

If you have any questions, please contact Lisa Butler at (386) 961-7382 or lisa.butler@dot.state.fl.us or Sandra Brink at (386) 961-7585 or sandra.brink@dot.state.fl.us.

Sincerely,

Sandra Brink / Lisa Butler
District Maintenance Contract Managers

COLUMBIA COUNTY

EXHIBIT "A"

Contract ANJ85

Maintaining Agency Contact: Ben Scott, County Manager

Contact phone number: 386-758-1005

Current Approved Amount for 2019/2020: \$131,636.44

Maintaining Agency Signature

Date

Typed Official's Name / Title

Jennifer J. Curls, D2 Maintenance Contracts Administrator

Date

William N. Watts, Jr., P.E., Director of Operations

Date

COLUMBIA COUNTY

"EXHIBIT C"

Contract ANJ85 Street Lighting Inventory Report

Maintaining Agency Contact: Ben Scott, County Manager

Contact phone number: 386-758-1005

State Road	From	To	Street Lights
SR 47	Michigan Ave.	CR 242	200
SR 441	SR 441 & Tiger Drive		1
SR 47	Wester Drive & King Road		1
SR 10A	Locjlyn	US 90 E	56
SR 10 (US 90)	West City Limits to Turner Road	End of Curb and Gutter West	28
SR 441	100A	1-10	208
SR 100	SR 100 & Williams Road		1
SR 247	Fire & Rescue	US 90	7
		TOTAL	502

COLUMBIA COUNTY
Damage and Outage Report
Contract ANJ85

Maintaining Agency Contact: Ben Scott, County Manager

Contact phone number: 386-758-1005

State Road	To	From	Date Reported	To Whom



**COLUMBIA COUNTY BOARD OF COUNTY COMMISSIONERS
AGENDA ITEM REQUEST FORM**

The Board of County Commissioners meets the 1st and 3rd Thursday of each month at 5:30 p.m. in the Columbia County School Board Administrative Complex Auditorium, 372 West Duval Street, Lake City, Florida 32055. All agenda items are due in the Board's office one week prior to the meeting date.

Today's Date: 3/7/2019 **Meeting Date:** 3/21/2019

Name: Kevin Kirby **Department:** Public Works

Division Manager's Signature: 

1. Nature and purpose of agenda item:

Utility Permit from FPL for Quinten, Josephine, Audie, Sunnybrook, and Jimmy

2. Recommended Motion/Action:

Approve

3. Fiscal impact on current budget.

This item has no effect on the current budget.

COLUMBIA COUNTY BOARD OF COUNTY COMISSIONERS
UTILITY PERMIT

Date: 3/05/19 Permit No. County Road Section No.

Permittee Florida Power & Light

Address 9001 Ellis Rd., Melbourne, FL 32904 Telephone Number 321 72 4867

Requesting permission from Columbia County, Florida, hereinafter called the County, to contract, operate and maintain Replace 5 existing wood poles with proposed wood

Located Along NW Jimmy Way, Sunnybrook Rd, NE Audie Ter, NW Quinten St, and NW Josephine St

MOT 603 605

FROM: TO:

Submitted for the Utility Owner by: Melissa Slyter-Prmt Admn. Signature Date 3/05/2019

1. Permittee declares that prior to filing this application it has determined the location of all existing utilities, both aerial and underground and the accurate locations are shown on the plans attached hereto and made a part of this application. Proposed work is within corporate limits of Municipality: YES () NO (). If YES: LAKE CITY () FORT WHITE (). A letter of notification was mailed on to the following utility owners

2. The Columbia County Public Works Director shall be notified twenty-four (24) hours prior to starting work and again immediately upon completion of work. The Public Works Director is located at Telephone Number The PERMITTEE's employee responsible for Maintenance of Traffic is Telephone Number (This name may be provided at the time of the 24 hour notice to starting work.)

3. This PERMITTEE shall commence actual construction in good faith within days after issuance of permit, and shall be completed within 180 days after permitted work has begun. If the beginning date is more than 60 days from date of permit approval, then PERMITTEE must review the permit with the Columbia County Public Works Director to make sure no changes have occurred in the transportation facility that would affect the permitted construction.

4. The construction and maintenance of such utility shall not interfere with the property and rights of a prior PERMITTEE.

5. It is expressly stipulated that this permit is a license for permissive use only and that the placing of utilities upon public property pursuant to this permit shall not operate to create or vest any property right in said holder.

6. Pursuant to Section 337-403(1), Florida Statutes, whenever necessary for the construction, repair, improvement, maintenance, safe and efficient operation, alteration or relocation of all, or any portion of said transportation facility as determined by the Columbia County Public Works Director and/or County Engineer, any or all utilities and appurtenances authorized hereunder, shall be immediately removed from said transportation facility or reset or

relocated thereon as required by the Columbia County Public Works Director and/or County Engineer and at the expense of the PERMITTEE.

7. In case of non-compliance with the County's requirements in effect as of the approval date of this permit, this permit void and the facility will have to be brought into compliance or removed from the right of way at no cost to the County.

8. It is understood and agreed that the rights and privileges herein set out are granted only to the extent of the County's right, title and interest in the land to be entered upon and used by the PERMITTEE, and the PERMITTEE will, at all times, and to the extent permitted by law, assume all risk of and indemnify, defend, and save harmless Columbia County, Florida from any and all loss, damage, cost or expense arising in any manner on account of the exercise or attempted exercise by said PERMITTEE of the aforesaid right and privileges.

9. During construction, all safety regulations of the County shall be observed and the PERMITTEE must take measures, including pacing and the display of safety devices that may be necessary in order to safely conduct the public through the project area in accordance with the Federal Manual on Uniform Traffic Control Devices, as amended for highways.

10. Should the PERMITTEE be desirous of keeping its utilities in place and out of service, the PERMITTEE, by execution of this permit acknowledges its present and continuing ownership of its utilities located between _____ and _____ within the County's right of way as set forth above. PERMITTEE, as its sole expense, shall promptly remove said out of service utilities whenever Columbia County Public Works Director and/or County Engineer determines said removal is in the public interest.

11. Special instructions: Minimum cover of thirty inches (30") will be required at all locations. Columbia County will not be financially responsible for any damage to facilities with less than thirty inches (30") cover. Cables shall not be located within driveway ditches.

12. Additional Stipulations: _____

It is understood and agreed that commencement by the PERMITTEE is acknowledgment and acceptance of the binding nature of these specialist instructions.

Submitted By: Melissa Slyter
Permittee

Place Corporate Seal

Melissa Slyter
Signature and Title Permit Admin.

Attested _____

Utilities Permit
Page three
Revised: 8/17/00

Recommended for Approval:

Signature: _____ 

Title: **Assistant County Manager**

Date: **3-7-19**

Approval by Board of County Commissioners, Columbia County, Florida:

YES () NO ()

Date Approved: _____

Chairman's Signature: _____

INAC ESSLBLE 3 kV FUTURE 23 kV 23 kV SALT SPRAY

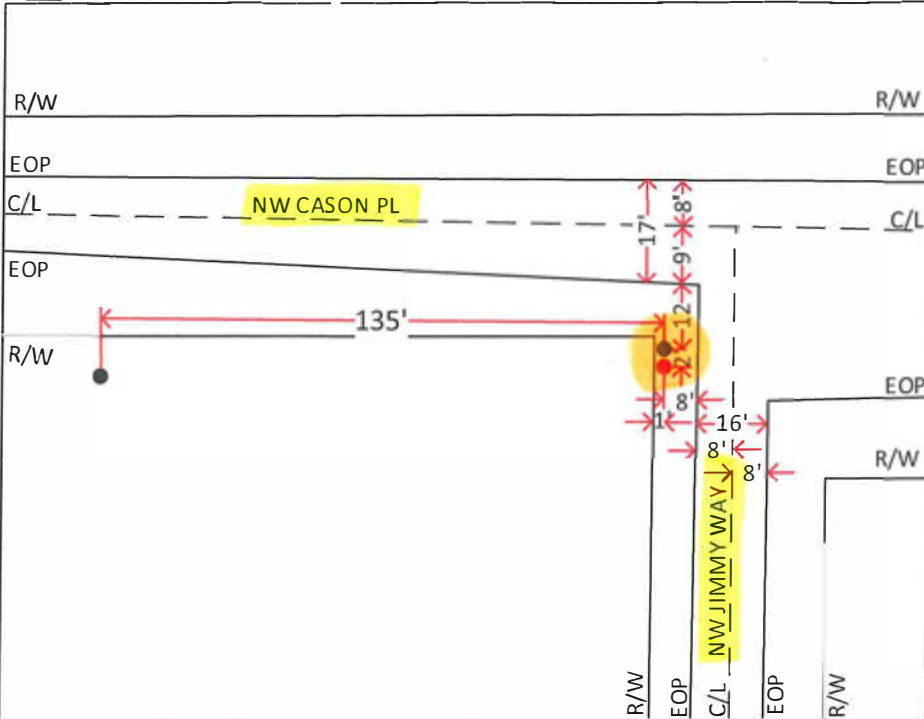

**CALL SUNSHINE #811
48 HOURS BEFORE YOU DIG
LOCATE MARKINGS COLOR CODE**

 ELECTRIC	 WATER
 GAS-OIL-STEAM	 SEWER
 TEMP. SURVEY MARKINGS	 CABLE TV
 PROPOSED EXCAVATION	

LOCATION 1 OF 5
 FPLID: 381159559
 FEEDER: GUMSWAMP 09462
 ADDRESS: 236 NW JIMMY WAY, LAKE CITY, FL
 LAT/LONG: 30.23222 684, -82.63968 646
MOT: 605

CONSTRUCTION NOTES:
 - PROPOSED REMOVE WOOD POLE SIZE 40'3
 - PROPOSED WOOD POLE SIZE 40'2
 - VIEW LOOKING SW FROM NW CASON PL
 - ALL MEASUREMENTS FROM MIDPOINT OF POLES

FPL Construction Symbols

- PROPOSED WOOD POLE
- EXISTING WOOD POLE
- PROPOSED CONCRETE POLE
- EXISTING CONCRETE POLE
- PROPOSED ANCHOR
- EXISTING ANCHOR

American Disabilities Act
 If pole placement location does not meet the minimum single point distance of 32" from edge of curb or back of sidewalk, contact your Production Lead, for further instructions.

Replace existing wood with proposed wood



AS-BUILT CREW PRINT		ALL REQUIRED GRAV AND RDS HAVE BEEN DRAWN & VERIFIED TO BE WITHIN FPL STANDARDS, VALUES ARE SHOWN AT ALL LOCATIONS.				JOB CERTIFIED COMPLETED AS SHOWN ON THIS AS-BUILT PRINT. MATERIAL CHANGES SHOWN ON RGS				AS-BUILT COPY					
FORBMAN'S SIGNATURE _____		DATE _____		FORBMAN'S SIGNATURE _____		DATE _____		SUPERVISOR'S SIGNATURE _____		DATE _____		INITIALS _____		CERT. DATE _____	
Easement? Yes <input type="checkbox"/> No <input checked="" type="checkbox"/>		Survey/Stake? Yes <input type="checkbox"/> No <input checked="" type="checkbox"/>		Work with SMO? Yes <input type="checkbox"/> No <input checked="" type="checkbox"/>		FPL		COLUMBIA COUNTY POLE REPLACEMENT 236 NW JIMMY WAY, LAKE CITY, FL				Job Owner: JANET GARCIA		Phone: (305) 863-4949	
Tree Work? Yes <input type="checkbox"/> No <input checked="" type="checkbox"/>		Designer/Stake? Yes <input type="checkbox"/> No <input checked="" type="checkbox"/>		CT/Special Mtr? Yes <input type="checkbox"/> No <input checked="" type="checkbox"/>											
Trees Access? Yes <input type="checkbox"/> No <input checked="" type="checkbox"/>		Tree Staking Req? Yes <input type="checkbox"/> No <input checked="" type="checkbox"/>		Telephone Co. Job No. _____		Drawn by: TXK		Check by: DCP		Dwg No. 1 OF 5		Rural Location Sec. 17 TWP. 03 S.R. 17 E.		SCALE: N.T.S	
Requested Tel. Co. Set Poles? YES <input type="checkbox"/> NO <input checked="" type="checkbox"/>		Requested Tel. Co. Transfer? YES <input type="checkbox"/> NO <input checked="" type="checkbox"/>		Request CATV Transfer? YES <input type="checkbox"/> NO <input checked="" type="checkbox"/>		POLE LINE FEET 0'		DUCT BANK FT. 0'		TRENCH FT. 0'		St. Lt MAP No. _____		Pri Map No. KW1150	
TLM/LDS MODEL No. _____		Map Posting? YES <input type="checkbox"/> NO <input checked="" type="checkbox"/>		Posted by: _____		WR 8605498		M/A		NF					

INACCESSIBLE 13 kV FUTURE 23 kV 23 kV SALT SPRAY

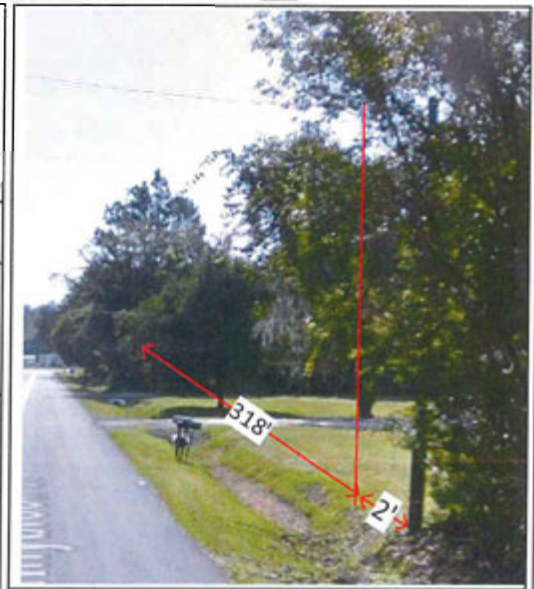
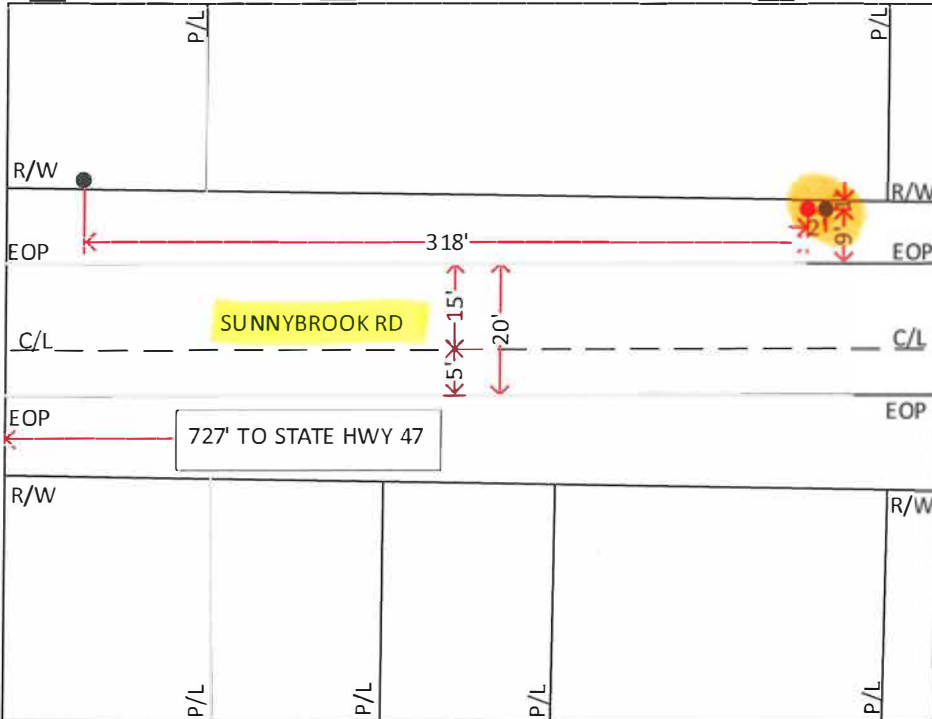

**CALL SUNSHINE #811
48 HOURS BEFORE YOU DIG
LOCATE MARKINGS COLOR CODE**

 ELECTRIC	 WATER
 GAS-OIL-STEAM	 SEWER
 TEMP. SURVEY MARKINGS	 CABLE TV
 PROPOSED EXCAVATION	

LOCATION 2 OF 5
 FPLID: 381195482
 FEEDER: GUMSWAMP(09462)
 ADDRESS: 223 NE SUNNYBROOK ST, LAKE CITY, FL
 LAT/LONG: 30.21910877, -82.63589013

MOT: 603

CONSTRUCTION NOTES:
 - PROPOSED REMOVE WOOD POLE SIZE 30' 5
 - PROPOSED INSTALL WOOD POLE SIZE 35' 4
 - VIEW LOOKING EAST FROM NE SUNNYBROOK ST
 - ALL MEASUREMENTS FROM MIDPOINT OF POLES

FPL Construction Symbols

- PROPOSED WOOD POLE
- EXISTING WOOD POLE
- PROPOSED CONCRETE POLE
- EXISTING CONCRETE POLE
- PROPOSED ANCHOR
- EXISTING ANCHOR

American Disabilities Act
 If pole placement location does not meet the minimum single point distance of 32" from edge of curb or back of sidewalk, contact your Production Lead, for further instructions.

Replace existing wood with proposed wood



AS-BUILT CREW PRINT		<small>ALL REQUIRED GROUND RODS HAVE BEEN DRIVEN & VERIFIED TO BE WITHIN FPL STANDARDS, VALUES ARE SHOWN AT ALL LOCATIONS</small>		<small>FOR CEREAL COMPLIANCE WITH SECTION 1034.5-BUILD PRINT, MATERIAL CHANGES SHOWN ON JOB</small>		AS-BUILT COPY	
FOR MANAGER SIGNATURE _____		DATE _____		FOR MANAGER SIGNATURE _____		DATE _____	
Easement? Yes <input type="checkbox"/>	Survey/Stake? Yes <input checked="" type="checkbox"/>	Work with SMO? Yes <input type="checkbox"/>	FPL		COLUMBIA COUNTY POLE REPLACEMENT 223 NE SUNNYBROOK ST, LAKE CITY, FL		
Tree Work? Yes <input type="checkbox"/>	Designer/Stake? Yes <input checked="" type="checkbox"/>	CT/Special Mtr? Yes <input type="checkbox"/>					
Trees Access? Yes <input type="checkbox"/>	Tree Staking Req? Yes <input checked="" type="checkbox"/>		P/BMIT: City _____ County Rd. _____ County Air _____ State Road _____ FAA _____ REL'D: WMD _____ RR Xing _____ DR. Dist. _____ Transm. _____		Job Owner: JANET GARCIA Phone: (305) 863-4949 Designed by: AKRITALSOHAL Date: 22-FEB-2019 Drawn by: TXK Check by: DCP Dwg No. 2 OF 5		
Requested Tel. Co. Set Poles? YES <input type="checkbox"/> NO <input checked="" type="checkbox"/>	Tele. Attachment Per _____		Rural Location Sec. 20 TWP. 03 S.R. 17 E.		SCALE: N.T.S St. Lt MAP No. _____ Pri Map No. KW1147		
Requested Tel. Co. Transfer? YES <input type="checkbox"/> NO <input checked="" type="checkbox"/>	Telephone Co. Job No. _____		POLE LINE FEET 0'		DUCT BANK FT. 0'		
Request CATV Transfer? YES <input type="checkbox"/> NO <input checked="" type="checkbox"/>	POLE LINE FT. ON TRANSM. POLES 0'		TRENCH FT. 0'		WR 8605498 M/A NF		
TLM/LDS MODEL No. _____	Map Posting? YES <input type="checkbox"/> NO <input checked="" type="checkbox"/> Posted by: _____						

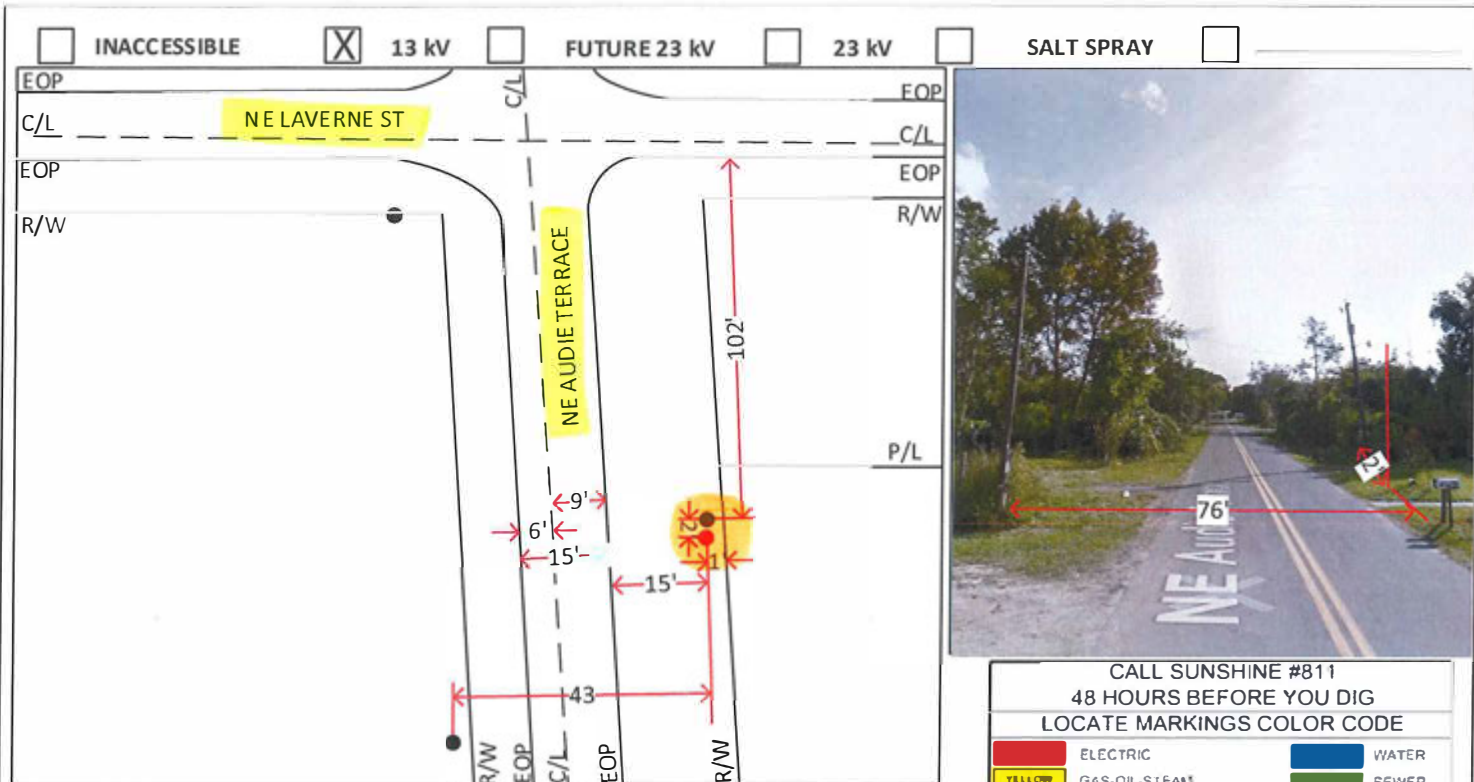

LOCATION 3 OF 5
 FPLID: 381195503
 FEEDER: GUMSWAMP(09462)
 ADDRESS: 217 NE AUDIE TERRACE, LAKE CITY, FL
 LAT/LONG: 30.21603909, -82.63449693
 MOT: 605

CONSTRUCTION NOTES:
 - PROPOSED REMOVE WOOD POLE SIZE 30'/6
 - PROPOSED WOOD POLE SIZE 35'4
 - VIEW LOOKING SOUTH FROM NE AUDIE TERRACE
 - ALL MEASUREMENTS FROM MIDPOINT OF POLES

- FPL Construction Symbols**
- PROPOSED WOOD POLE
 - EXISTING WOOD POLE
 - PROPOSED CONCRETE POLE
 - EXISTING CONCRETE POLE
 - PROPOSED ANCHOR
 - EXISTING ANCHOR

CALL SUNSHINE #811
 48 HOURS BEFORE YOU DIG
 LOCATE MARKINGS COLOR CODE

■ ELECTRIC	■ WATER
■ GAS-OIL-STEAM	■ SEWER
■ TEMP. SURVEY MARKINGS	■ CABLE TV
■ PROPOSED EXCAVATION	

American Disabilities Act
 If pole placement location does not meet the minimum single point distance of 32" from edge of curb or back of sidewalk, contact your Production Lead, for further instructions.

Replace existing wood with proposed wood



AS-BUILT CREW PRINT		ALL REQUIRED GROUND RODS HAVE BEEN DRIVEN & VERIFIED TO BE WITHIN FPL STANDARDS, VA LINES ARE SHOWN AT ALL LOCATIONS.		JOB CERTIFIED COMPLETED AS SHOWN ON THIS AS-BUILT PRINT. MATERIAL CHANGES SHOWN ON ROS.		AS-BUILT COPY	
FORMAN SIGNATURE _____ DATE _____		FORMAN SIGNATURE _____ DATE _____		SUPERVISOR SIGNATURE _____ DATE _____		INITIALS _____ CERT. DATE _____	
Easement? Yes <input type="checkbox"/> No <input checked="" type="checkbox"/>	Survey/Stake? Yes <input checked="" type="checkbox"/> No <input type="checkbox"/>	Work with SMO? Yes <input type="checkbox"/> No <input checked="" type="checkbox"/>	FPL				
Tree Work? Yes <input type="checkbox"/> No <input checked="" type="checkbox"/>	Designer/Stake? Yes <input checked="" type="checkbox"/> No <input type="checkbox"/>	CT/Special Mtr? Yes <input type="checkbox"/> No <input checked="" type="checkbox"/>					
Trees Access? Yes <input type="checkbox"/> No <input checked="" type="checkbox"/>	Tree Staking Req'd? Yes <input type="checkbox"/> No <input checked="" type="checkbox"/>		COLUMBIA COUNTY POLE REPLACEMENT 217 NE AUDIE TERRACE, LAKE CITY, FL				
City	County Rd.	County Air	State Road	FAA	Job Owner:	JANET GARCIA	Phone: (305) 863-4949
WMD	RR Xing	DR. Dist.	Transm.		Designed by:	AKRITALSOHAL	Date: 20-FEB-2019
Requested Tel. Co. Set Poles? YES <input type="checkbox"/> NO <input checked="" type="checkbox"/>	Requested Tel. Co. Transfer? YES <input type="checkbox"/> NO <input checked="" type="checkbox"/>	Request CAIV Transfer? YES <input type="checkbox"/> NO <input checked="" type="checkbox"/>	Tele. Attachment Per _____ Telephone Co. Job No. _____		Drawn by:	TXK	Check by: DCP
POLE LINE FEET	0'	DUCT BANK FT.	0'	Rural Location Sec.	20	TWP.	03
POLE LINE FT. ON TRANSM. POLES	0'	TRENCH FT.	0'	SCALE:	N.T.S	St. Lt MAP No.	Pri Map No. KW1147
TLM/LDS MODEL No.	-	Map Post	YES <input type="checkbox"/> NO <input checked="" type="checkbox"/>	Posted by:	WR	8605498	M/A? NF

INACCESSIBLE 13 kV FUTURE 23 kV 23 kV SALT SPRAY

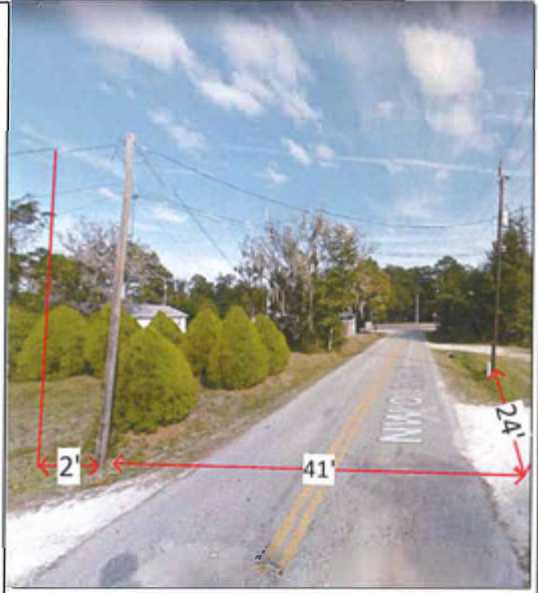
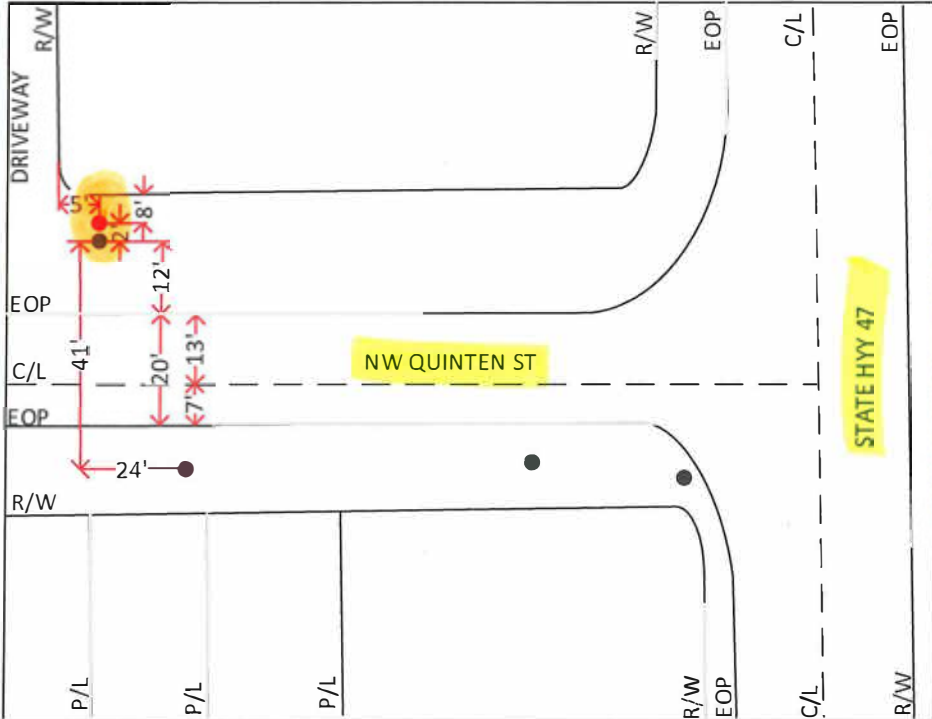

CALL SUNSHINE #811
48 HOURS BEFORE YOU DIG
LOCATE MARKINGS COLOR CODE

	ELECTRIC		WATER
	GAS-OIL-STEAM		SEWER
	TEMP SURVEY MARKINGS		CABLE TV
	PROPOSED EXCAVATION		

LOCATION 4 OF 5
FPLID: 381195482
FEEDER: GUMSWAMP(09462)
ADDRESS: 151 NW QUINTEN ST, LAKE CITY, FL
LAT/LONG: 30.21850899, -82.63894289
MOT: 605

FPL Construction Symbols

- PROPOSED WOOD POLE
- EXISTING WOOD POLE
- PROPOSED CONCRETE POLE
- EXISTING CONCRETE POLE
- PROPOSED ANCHOR
- EXISTING ANCHOR

American Disabilities Act
If pole placement location does not meet the minimum single point distance of 32" from edge of curb or back of sidewalk, contact your Production Lead, for further instructions.

CONSTRUCTION NOTES:
- PROPOSED REMOVE WOOD POLE SIZE 30' 4
- PROPOSED WOOD POLE SIZE 35' 4
- VIEW LOOKING WEST FROM NW QUINTEN ST
- ALL MEASUREMENTS FROM MIDPOINT OF POLES

Replace existing wood with proposed wood



AS-BUILT CREW PRINT		ALL REQUIRED GROUNDWORKS HAVE BEEN DRIVEN & VERIFIED TO BE WITHIN FPL STANDARDS, VALUES ARE SHOWN AT ALL LOCATIONS.		JOB CERTIFIED TO MEET TEXAS SHOWDOWN THIS AS-BUILT PRINT. MATERIAL CHANGES SHOWN ON ROS		AS-BUILT COPY	
FOREMAN'S SIGNATURE _____ DATE _____		FOREMAN'S SIGNATURE _____ DATE _____		SUPERVISOR'S SIGNATURE _____ DATE _____		INITIALS _____ CERT. DATE _____	
Easement? Yes <input type="checkbox"/>	Survey/Stake? Yes <input checked="" type="checkbox"/>	Work with SMO? Yes <input type="checkbox"/>	<input checked="" type="checkbox"/>	FPL			
Tree Work? Yes <input type="checkbox"/>	Designer/Stake? Yes <input checked="" type="checkbox"/>	CT/Special Mtr? Yes <input type="checkbox"/>	<input checked="" type="checkbox"/>				
Trees Access? Yes <input type="checkbox"/>	Tree Staking Req? Yes <input type="checkbox"/>			COLUMBIA COUNTY POLE REPLACEMENT 151 NW QUINTEN ST, LAKE CITY, FL			
PBRM# City	County Rd.	County Air	State Road	FAA	Job Owner:	JANET GARCIA	Phone: (305) 863-4949
RR# WMD	RR Xing	DR. Dist.	Transm.		Designed by:	AKRITALSOHAL	Date: 19/10/2018
Requested Tel. Co. Set Poles? YES <input type="checkbox"/> NO <input checked="" type="checkbox"/>	Tele. Attachment Per	Requested Tel. Co. Transfer? YES <input type="checkbox"/> NO <input checked="" type="checkbox"/>	Telephone Co. Job No.	Drawn by:	TXK	Check by:	DCP
Request CATV Transfer? YES <input type="checkbox"/> NO <input checked="" type="checkbox"/>				Dwg No.	4 OF 5		
POLE LINE FEET 0'	DUCT BANK FT. 0'	Rural Location Sec.	19 TWP. 03	S.R.	17 E.		
POLE LINE FT. ON TRANSM. POLES 0'	TRENCH FT. 0'	SCALE:	N.T.S	St. Lt MAP No.	Pri Map No. KW1147		
TLM/LDS MODEL No. -	Map Posting? YES <input type="checkbox"/> NO <input checked="" type="checkbox"/>	Posted by:	WR 8605498	M/A	NF		

ACCESSIBLE 13 kV FUTURE 23 kV 23 kV SALT SPRAY

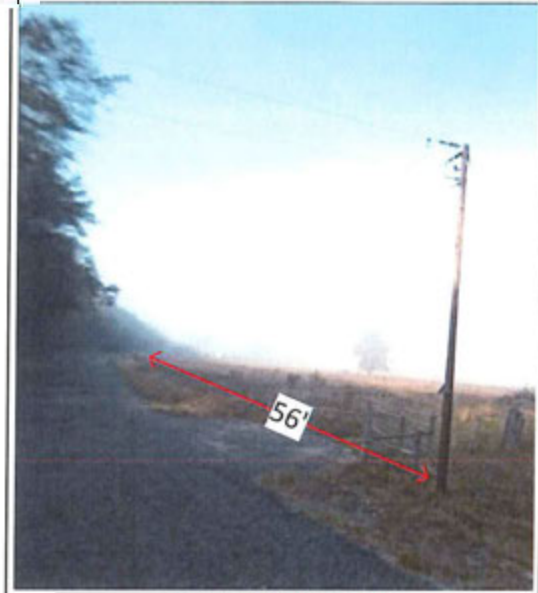
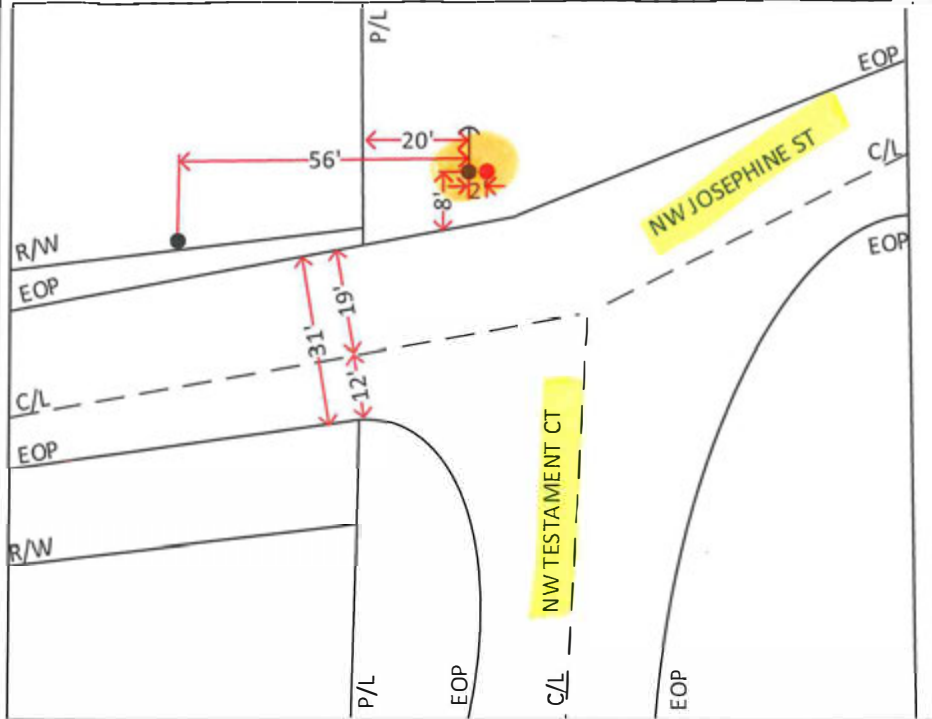

**CALL SUNSHINE #811
48 HOURS BEFORE YOU DIG
LOCATE MARKINGS COLOR CODE**

	ELECTRIC		WATER
	GAS-OIL-STEAM		SEWER
	TEMP. SURVEY MARKINGS		CABLE TV
	PROPOSED EXCAVATION		

LOCATION 5 OF 5
 FPLID: 381195511
 FEEDER: GUMSWAMP(09462)
 ADDRESS: N/O NW JOSEPHINE ST & NW TESTAMENT CT, LAKE CITY, FL
 LAT/LONG: 30.26945046, -82.64332427
 MOT: 605

FPL Construction Symbols

- PROPOSED WOOD POLE
- EXISTING WOOD POLE
- PROPOSED CONCRETE POLE
- EXISTING CONCRETE POLE
- PROPOSED ANCHOR
- EXISTING ANCHOR

American Disabilities Act

If pole placement location does not meet the minimum single point distance of 32" from edge of curb or back of sidewalk, contact your Production Lead, for further instructions.

CONSTRUCTION NOTES:

- PROPOSED REMOVE WOOD POLE SIZE 35'/5
- PROPOSED WOOD POLE SIZE 40'/2
- VIEW LOOKING WEST FROM NW JOSEPHINE ST
- ALL MEASUREMENTS FROM MIDPOINT OF POLES



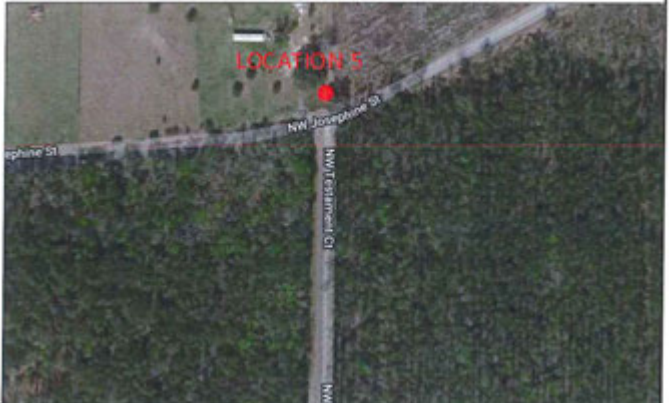

Replace existing wood with proposed wood

Location stamps



AS-BUILT CREW PRINT		ALL REQUIRED GROUND RODS HAVE BEEN DRIVEN & VERIFIED TO BE WITHIN FPL STANDARDS, VA LINES ARE SHOWN AT ALL LOCATIONS.		JOB CERTIFIED COMPLETED AS SHOWN ON THIS AS-BUILT PRINT. MATERIAL CHANGES SHOWN ON ROS		AS-BUILT COPY	
FORWARDER'S SIGNATURE		DATE		FORWARDER'S SIGNATURE		DATE	
FORWARDER'S SIGNATURE		DATE		SUPERVISOR'S SIGNATURE		DATE	
INITIALS		CERT. DATE		INITIALS		CERT. DATE	
Easement? Yes <input type="checkbox"/>		Survey/Stake? Yes <input checked="" type="checkbox"/>		Work with SMO? Yes <input type="checkbox"/>		FPL	
Tree Work? Yes <input type="checkbox"/>		Designer/Stake? Yes <input checked="" type="checkbox"/>		CT/Special Mtr? Yes <input type="checkbox"/>		COLUMBIA COUNTY	
Trees Access? Yes <input type="checkbox"/>		Tree Staking Req'd? Yes <input type="checkbox"/>				POLE REPLACEMENT	
City		County Rd.		County Air		State Road	
WMD		RR Xing		DR. Dist.		Transm.	
Requested Tel. Co. Set Poles? YES <input type="checkbox"/> NO <input checked="" type="checkbox"/>		Requested Tel. Co. Transfer? YES <input type="checkbox"/> NO <input checked="" type="checkbox"/>		Request CATV Transfer? YES <input type="checkbox"/> NO <input checked="" type="checkbox"/>		Job Owner: JANET GARCIA	
POLE LINE FEET 0'		DUCT BANK FT. 0'		Rural Location Sec. 19 TWP. 03 S,R. 17 E.		Phone: (305) 863-4949	
POLE LINE FT. ON TRANSM. POLES 0'		TRENCH FT. 0'		SCALE: N.T.S		St. Lt MAP No.	
TLM/LDS MODEL No.		Map Posting? YES <input type="checkbox"/> NO <input checked="" type="checkbox"/>		Posted by: WR 8605498		Dwg No. 5 OF 5	
						Date: 22-FEB-2019	
						Designed by: AKRITALSOHAL	
						Drawn by: TXK Check by: DCP	
						Pri Map No. KW1147	
						M/A NF	

SYMBOLS:

-  Work Area
-  Channelizing Device (See Index 102-600)
-  Work Zone Sign
-  Flagger
-  Lane Identification + Direction of Traffic

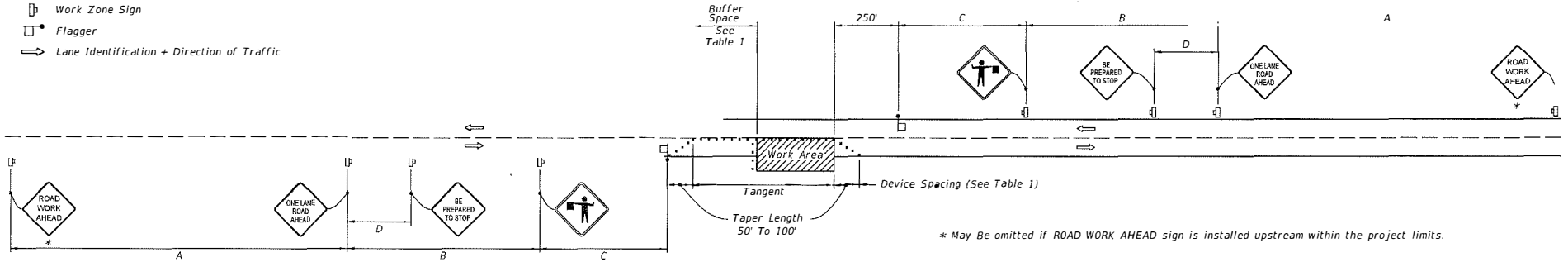

WITHOUT TEMPORARY RAISED RUMBLE STRIPS

GENERAL NOTES:

1. Special Conditions may be required in accordance with these notes and the following sheets:
 - A. Railroad Crossings:
 - a. If an active railroad crossing is located closer to the Work Area than the queue length plus 300 feet, extend the Buffer Space as shown on Sheet 3.
 - b. If the queuing of vehicles across an active railroad crossing cannot be avoided, provide a uniformed traffic control officer or flagger at the highway-rail grade crossing to prevent vehicles from stopping within the highway-rail grade crossing, even if automatic train warning devices are in place.
 - B. If the Work Area encroaches on the Centerline, use the Layout for Temporary Lane Shift to Shoulder on Sheet 3 only if the Existing Paved Shoulder width is sufficient to provide for an 11' Lane between the Work Area and the Edge of Existing Paved Shoulder. Reduce the posted speed when appropriate.
2. Temporary Raised Rumble Strips:
 - A. Use when both of the following conditions are met concurrently:
 - a. Existing Posted Speed is 55 mph or greater;
 - b. Work duration is greater than 60 minutes.
 - B. Use a consistent Strip color throughout the work zone.
 - C. Place each Rumble Strip Set transversely across the lane at locations shown.
 - D. Use Option 1 or Option 2 as shown on Sheet 2. Use only one option throughout work zone.
3. Additional one-way control may be provided by the following means:
 - A. Flag-carrying vehicle;
 - B. Official vehicle;
 - C. Pilot vehicles;
 - D. Traffic signals.

When flaggers are the sole means of one-way control, the flaggers must be in sight of each other or in direct communication at all times.
4. When a side road intersects the highway within the TTC zone, place additional TTC devices in accordance with other applicable TCZ Indexes.
5. The two channelizing devices directly in front of the work area may be omitted provided vehicles in the work area have high-intensity rotating, flashing, oscillating, or strobe lights operating.
6. When Buffer Space cannot be attained due to geometric constraints, use the greatest attainable length, not less than 200 ft, for posted speeds greater than 25 mph.
7. ROAD WORK AHEAD and the BE PREPARED TO STOP signs may be omitted if all of the following conditions are met:
 - A. Work operations are 60 minutes or less.
 - B. Speed limit is 45 mph or less.
 - C. There are no sight obstructions to vehicles approaching the work area for a distance equal to the Buffer Space shown in Table 1.
 - D. Vehicles in the work area have high-intensity, rotating, flashing, oscillating, or strobe lights operating.
 - E. Volume and complexity of the roadway has been considered.
 - F. If a railroad crossing is present, vehicles will not queue across rail tracks.
 - G. AFADs are not in use.
8. See Index 102-600 for general TCZ requirements and additional information.
9. Automated Flagger Assistance Devices (AFADs) may be used in accordance with Specifications Section 102, 990 and the APL vendor drawings.

**TABLE 1
DEVICE SPACING**

Posted Speed	Maximum Spacing of Cones or Tubular Markers		Maximum Spacing of Type I or Type II Barricades/Panels/Drums		Distance Between Signs				Buffer Space
					A	B	C	D	
	On a Taper	On a Tangent	On a Taper	On a Tangent					
25	20'	50'	20'	50'	200'	200'	200'	100'	155'
30	20'	50'	20'	50'	200'	200'	200'	100'	200'
35	20'	50'	20'	50'	200'	200'	200'	100'	250'
40	20'	50'	20'	50'	200'	200'	200'	100'	305'
45	20'	50'	20'	50'	350'	350'	350'	175'	360'
50	20'	50'	20'	100'	500'	500'	500'	250'	425'
55	20'	50'	20'	100'	2640'	1500'	1000'	500'	495'
60	20'	50'	20'	100'	2640'	1500'	1000'	500'	570'
65	20'	50'	20'	100'	2640'	1500'	1000'	500'	645'
70	20'	50'	20'	100'	2640'	1500'	1000'	500'	730'

CONDITIONS

WHERE ANY VEHICLE, EQUIPMENT, WORKERS OR THEIR ACTIVITIES ENCROACH THE AREA BETWEEN THE CENTERLINE AND A LINE 2' OUTSIDE THE EDGE OF TRAVEL WAY.

8/18/2018 10:24:22 AM

LAST REVISION 11/01/17

DESCRIPTION:







FY 2019-20
STANDARD PLANS

TWO-LANE, TWO-WAY,
WORK WITHIN THE TRAVEL WAY

INDEX SHEET
102-603 1 of 3

SYMBOLS:

-  Work Area
-  Channelizing Device (See Index 102-600)
-  Work Zone Sign
-  Flagger
-  Lane Identification + Direction of Traffic

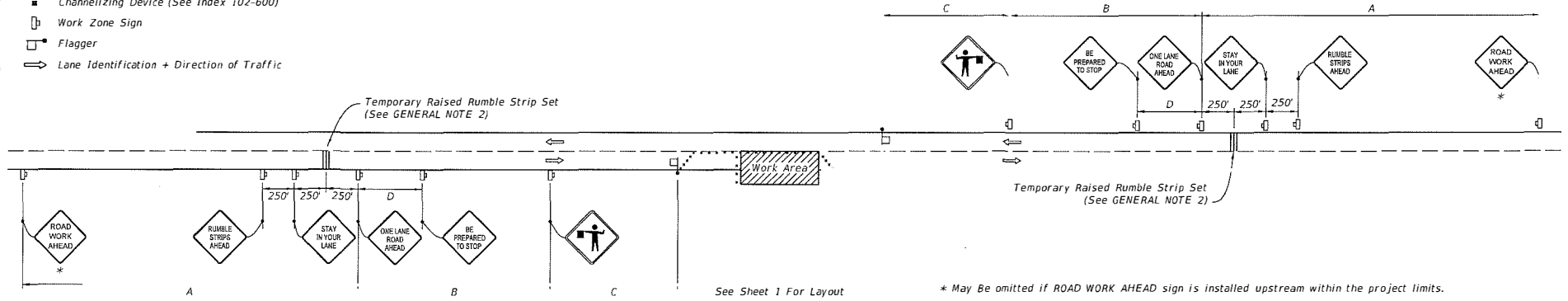

WITH TEMPORARY RAISED RUMBLE STRIPS
(When Required See GENERAL NOTE 2)

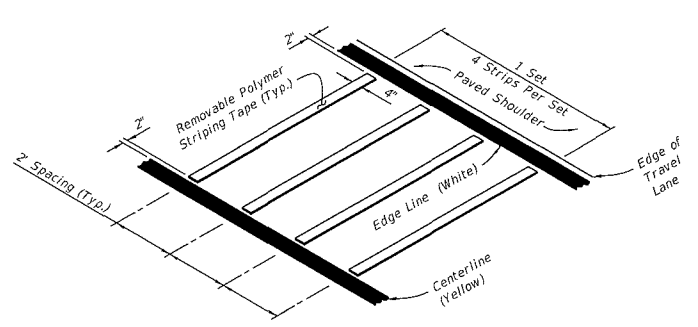

REMOVABLE POLYMER STRIPING TAPE

RUMBLE STRIP SET
OPTION - 1

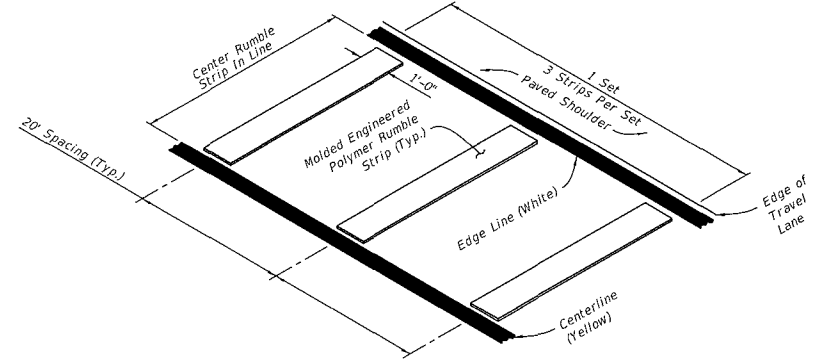

MOLDED ENGINEERED POLYMER SET

RUMBLE STRIP SET
OPTION - 2

TEMPORARY RAISED RUMBLE STRIPS

**TWO-LANE, TWO-WAY,
WORK WITHIN THE TRAVEL WAY**

INDEX	SHEET
102-603	2 of 3

10/24/22 MH

LAST REVISION	DESCRIPTION:
11/01/17	

FY 2019-20
STANDARD PLANS

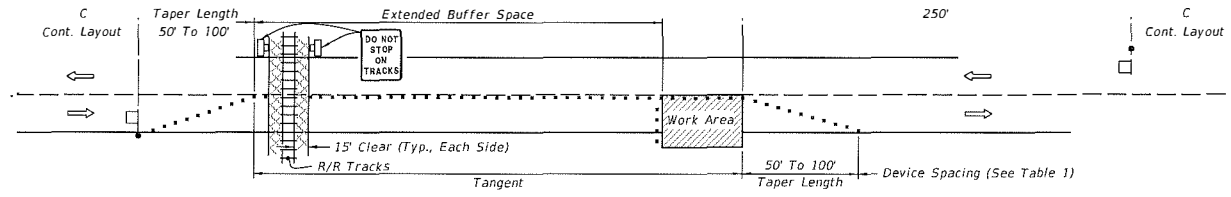

TEMPORARY RAILROAD CROSSING BUFFER SPACE EXTENSION

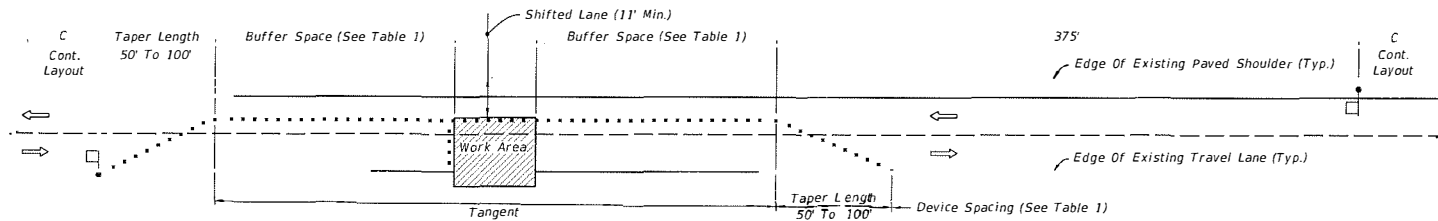

TEMPORARY LANE SHIFT TO SHOULDER WHEN WORK AREA ENCROACHES ON THE CENTERLINE

SPECIAL CONDITIONS

Cross Reference:
1. See General Note 1, Sheet 1 for more information.

9/18/2018 10:24:32 AM

LAST REVISION	DESCRIPTION:
11/01/17	

 FY 2019-20
 STANDARD PLANS

TWO-LANE, TWO-WAY,
 WORK WITHIN THE TRAVEL WAY

SPECIAL CONDITIONS

INDEX	SHEET
102-603	3 of 3

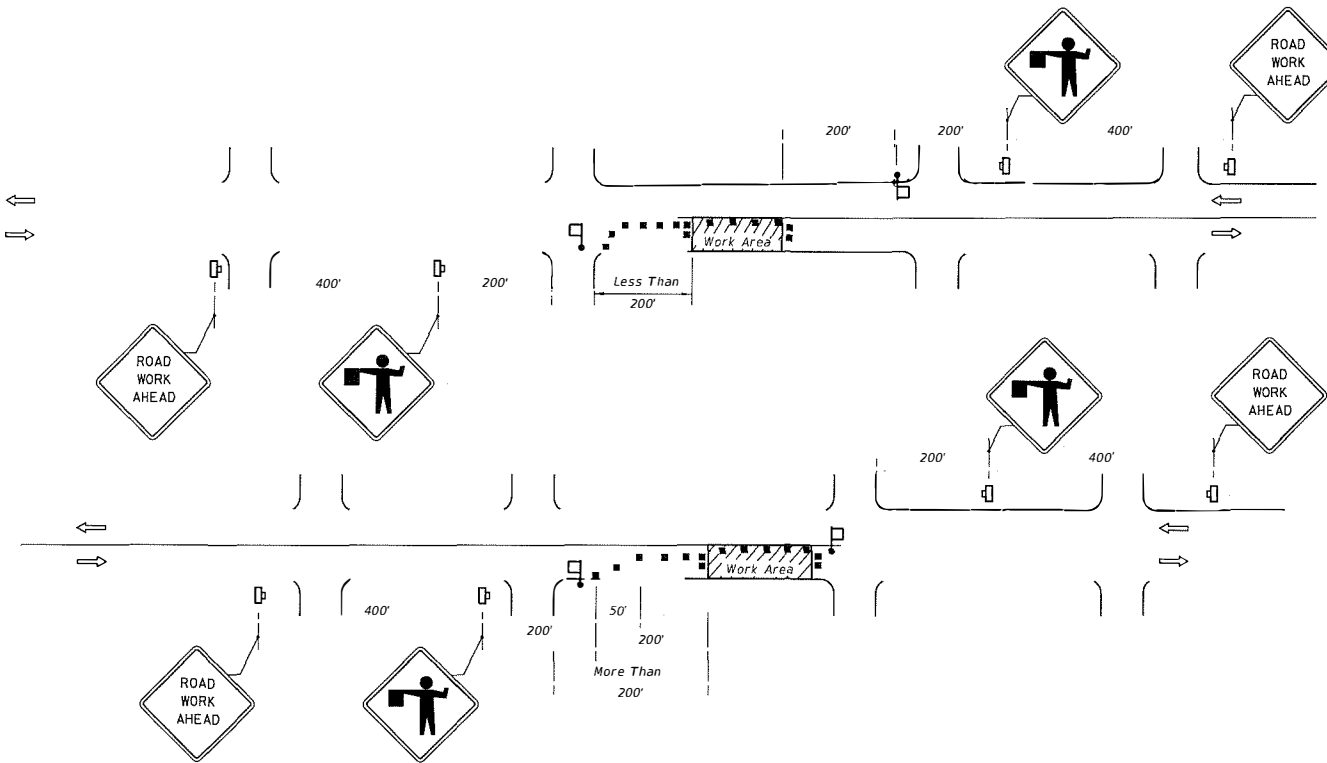

CONDITIONS

WHERE ANY VEHICLE, EQUIPMENT, WORKERS OR THEIR ACTIVITIES ENCRANCH ON THE PAVEMENT REQUIRING THE CLOSURE OF ONE TRAFFIC LANE, FOR WORK AREAS LESS THAN 200' DOWNSTREAM FROM AN INTERSECTION FOR A PERIOD OF MORE THAN 60 MINUTES.

CONDITIONS

WHERE ANY VEHICLE, EQUIPMENT, WORKERS OR THEIR ACTIVITIES ENCRANCH ON THE PAVEMENT REQUIRING THE CLOSURE OF ONE TRAFFIC LANE, FOR WORK AREAS 200' OR MORE DOWNSTREAM FROM AN INTERSECTION FOR A PERIOD OF MORE THAN 60 MINUTES.

DURATION NOTES

1. ROAD WORK AHEAD sign may be omitted if all of the following conditions are met:
 - a. Work operations are 60 minutes or less.
 - b. Speed is 45 mph or less.
 - c. No sight obstructions to vehicles approaching the work area for a distance of 600 feet.
 - d. Vehicles in the work area have high-intensity, rotating, flashing, oscillating, or strobe lights operating.
 - e. Volume and complexity of the roadway has been considered.

GENERAL NOTES

1. Work operations shall be confined to one travel lane, leaving the opposing travel lane open to traffic.
2. When vehicles in a parking zone block the line of sight to TCZ signs or when TCZ signs encroach on a normal pedestrian walkway, the signs shall be post mounted and located in accordance with Index 700-101.
3. If work area is confined to an outside auxiliary lane, the work area shall be barricaded and the FLAGGER signs replaced by ROAD WORK AHEAD signs. Flaggers are not required.
4. Flaggers shall be in sight of each other or in direct communication at all times.
5. The FLAGGER legend sign may be substituted for the symbol sign.
6. The maximum spacing between devices shall be no greater than 25'.
7. For general TCZ requirements and additional information, refer to Index 102-600.
8. The two channelizing devices directly in front and directly at the end of the work area may be omitted provided vehicles in the work area have high-intensity rotating, flashing, oscillating, or strobe lights operating.
9. Use Temporary Raised Rumble Strips in accordance with Index 102-603. Placement of Rumble Strips and additional signs should begin at FLAGGER sign location.

SYMBOLS

- Work Area
- Channelizing Device (See Index 102-600)
- Work Zone Sign
- Flagger
- Lane Identification + Direction of Traffic

10/25/17 201

LAST REVISION 11/01/17 DESCRIPTION:

FOOT FY 2019-20 STANDARD PLANS

TWO-LANE, TWO-WAY, WORK NEAR INTERSECTION

INDEX 102-605 SHEET 1 of 1



**COLUMBIA COUNTY BOARD OF COUNTY COMMISSIONERS
AGENDA ITEM REQUEST FORM**

The Board of County Commissioners meets the 1st and 3rd Thursday of each month at 5:30 p.m. in the Columbia County School Board Administrative Complex Auditorium, 372 West Duval Street, Lake City, Florida 32055. All agenda items are due in the Board's office one week prior to the meeting date.

Today's Date: 3/7/2019 Meeting Date: 3/21/2019

Name: Kevin Kirby Department: Public Works

Division Manager's Signature: 

1. Nature and purpose of agenda item:

Utility Permit from Comcast for Yates Loop

2. Recommended Motion/Action:

Approve

3. Fiscal impact on current budget.

This item has no effect on the current budget.

**COLUMBIA COUNTY BOARD OF COUNTY COMISSIONERS
UTILITY PERMIT**

Date: 1-29-19 Permit No. _____ County Road NW YATES LOOP Section No. _____

Permittee COMCAST (CATHERINE HODGES)

Address 7666 BLANDING BLVD, JAX, FL 32244 Telephone Number 904-777-9052 EXT 280

Requesting permission from Columbia County, Florida, hereinafter called the County, to contract, operate and maintain COMCAST PROPOSES TO PLACE 62FT OF OH CABLE ACROSS NW YATES LOOP

FROM: NW CHICKSAW GLEN TO: NW YATES LOOP

Submitted for the Utility Owner by: _____
Typed Name & Title Signature Date

1. Permittee declares that prior to filing this application it has determined the location of all existing utilities, both aerial and underground and the accurate locations are shown on the plans attached hereto and made a part of this application. Proposed work is within corporate limits of Municipality: YES () NO (). If YES: LAKE CITY () FORT WHITE (). A letter of notification was mailed on _____ to the following utility owners _____

2. The Columbia County Public Works Director shall be notified twenty-four (24) hours prior to starting work and again immediately upon completion of work. The Public Works Director is _____, located at _____ Telephone Number _____. The PERMITTEE's employee responsible for Maintenance of Traffic is _____ Telephone Number _____ (This name may be provided at the time of the 24 hour notice to starting work.)

3. This PERMITTEE shall commence actual construction in good faith within _____ days after issuance of permit, and shall be completed within _____ days after permitted work has begun. If the beginning date is more than 60 days from date of permit approval, then PERMITTEE must review the permit with the Columbia County Public Works Director to make sure no changes have occurred in the transportation facility that would affect the permitted construction.

4. The construction and maintenance of such utility shall not interfere with the property and rights of a prior PERMITTEE.

5. It is expressly stipulated that this permit is a license for permissive use only and that the placing of utilities upon public property pursuant to this permit shall not operate to create or vest any property right in said holder.

6. Pursuant to Section 337-403(1), Florida Statutes, whenever necessary for the construction, repair, improvement, maintenance, safe and efficient operation, alteration or relocation of all, or any portion of said transportation facility as determined by the Columbia County Public Works Director and/or County Engineer, any or all utilities and appurtenances authorized hereunder, shall be immediately removed from said transportation facility or reset or

relocated thereon as required by the Columbia County Public Works Director and/or County Engineer and at the expense of the PERMITTEE.

7. In case of non-compliance with the County's requirements in effect as of the approval date of this permit, this permit void and the facility will have to be brought into compliance or removed from the right of way at no cost to the County.

8. It is understood and agreed that the rights and privileges herein set out are granted only to the extent of the County's right, title and interest in the land to be entered upon and used by the PERMITTEE, and the PERMITTEE will, at all times, and to the extent permitted by law, assume all risk of and indemnify, defend, and save harmless Columbia County, Florida from any and all loss, damage, cost or expense arising in any manner on account of the exercise or attempted exercise by said PERMITTEE of the aforesaid right and privileges.

9. During construction, all safety regulations of the County shall be observed and the PERMITTEE must take measures, including pacing and the display of safety devices that may be necessary in order to safely conduct the public through the project area in accordance with the Federal Manual on Uniform Traffic Control Devices, as amended for highways.

10. Should the PERMITTEE be desirous of keeping its utilities in place and out of service, the PERMITTEE, by execution of this permit acknowledges its present and continuing ownership of its utilities located between _____ and _____ within the County's right of way as set forth above. PERMITTEE, as its sole expense, shall promptly remove said out of service utilities whenever Columbia County Public Works Director and/or County Engineer determines said removal is in the public interest.

11. Special instructions: Minimum cover of thirty inches (30") will be required at all locations. Columbia County will not be financially responsible for any damage to facilities with less than thirty inches (30") cover. Cables shall not be located within driveway ditches.

12. Additional Stipulations: _____

It is understood and agreed that commencement by the PERMITTEE is acknowledgment and acceptance of the binding nature of these specialist instructions.

Submitted By: CATHERINE HODGES _____
Permittee

Place Corporate Seal



Signature and Title PROJECT COORDINATOR

Attested

Utilities Permit
Page three
Revised: 8/17/00

Recommended for Approval:

Signature: _____ 

Title: _____ **Assistant County Manager** _____

Date: _____ **3-7-19** _____

Approval by Board of County Commissioners, Columbia County, Florida:

YES () NO ()

Date Approved: _____

Chairman's Signature: _____

429 NW YATES LOOP
 COUNTY PERMIT
 COVER

BINDING SPACE



SITE MAP
 SCALE: NONE

MOT NOTES

TRAFFIC CONTROL SHALL COMPLY WITH FEDERAL MANUAL ON UNIFORM TRAFFIC CONTROL DEVICES (MUTCD) AND F.D.O.T. DESIGN STANDARD #NO. 600.



COLUMBIA COUNTY, FL
 RIGHT-OF-WAY PERMIT

SUBJECT:
 PROPOSED AERIAL CATV
 FACILITIES ON NW YATES
 LOOP

CIFA:
 N/A

PROJECT TOTALS

PROP. BURIED CATV:	0'
PROP. OH CATV:	62'
TOTAL PROP. CATV:	62' (0.03MI.)

429 NW YATES LOOP
 COUNTY: COLUMBIA
 STATE: FLORIDA
 SHEET NO.: 1 OF 4
 DATE: 01/25/2019
 MAP: N/A
 DRAFTED BY: K. SANTANA

429 NW YATES LOOP COUNTY PERMIT NOTES & TYPICALS

BINDING SPACE

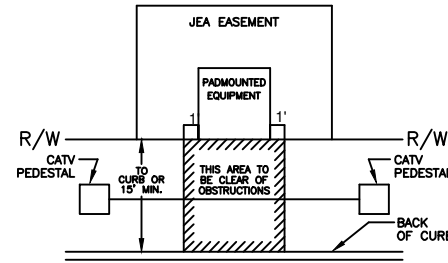

NOTE:
PLACE PEDESTALS TO THE LEFT OR RIGHT SIDE OF JEA TRANSFORMER LOCATIONS.

TYPICAL JEA EASEMENT
N.T.S.

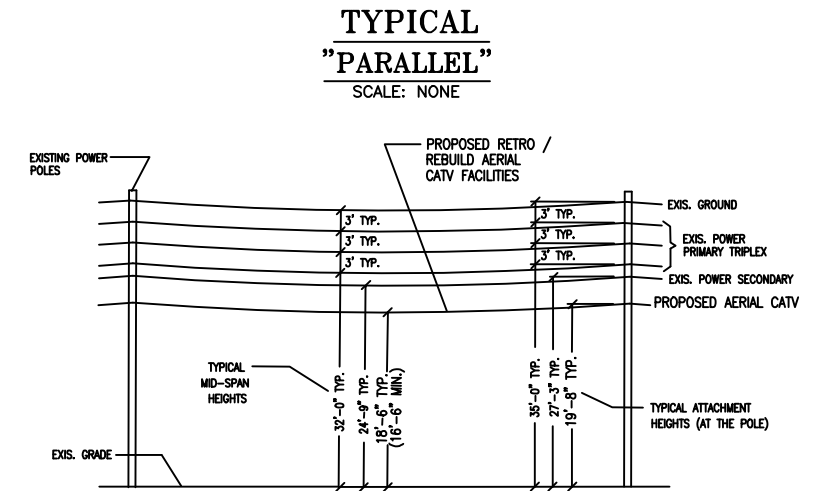

TYPICAL "PARALLEL"
SCALE: NONE

ALL UTILITIES LOCATED BY VISUAL INSPECTION, TO VERIFIED BY LOCATES.

EOT REPRESENTS EDGE OF TRAVEL NOT TRUE EDGE OF PAVEMENT.

E/P REPRESENTS THE TRUE EDGE OF PAVEMENT.

EOD REPRESENTS THE EDGE OF DIRT.

HAND DIG TRENCHES 36" DEEP ACROSS DIRT ROAD.

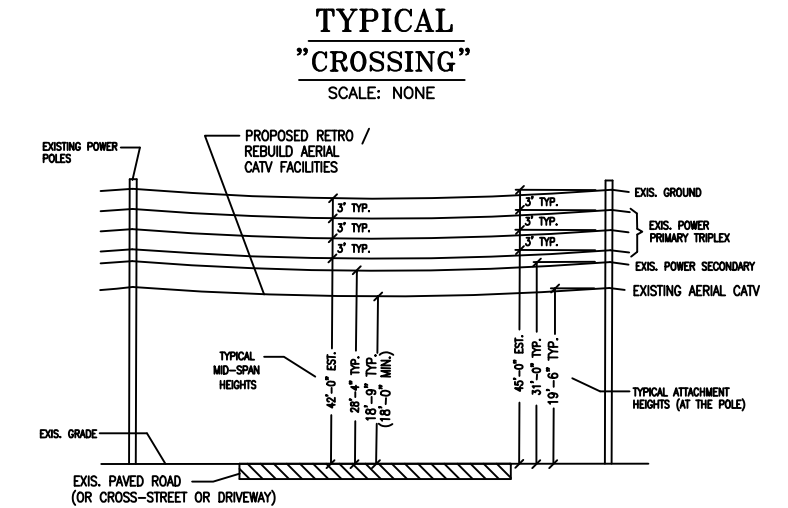

TYPICAL "CROSSING"
SCALE: NONE

COLUMBIA COUNTY AERIAL NOTES

ALL PROPOSED CONSTRUCTION WILL BE PER COLUMBIA COUNTY SPECIFICATIONS AS WELL AS ALL NESC SAFETY CODES.

ALL PROPOSED CATV WILL BE WITHIN THE COLUMBIA COUNTY RIGHT-OF-WAY.

ALL PROPOSED CATV WILL BE .700" OR .840" DIAMETER, INSULATED COAXIAL CABLE OR 1.0" DIAMETER, INSULATED FIBER OPTIC CABLE, AND WILL BE LASHED TO .250" STEEL STRAND CABLE USING .125" STD. GALV. LASHING WIRE.

ALL PROPOSED AERIAL CATV CROSSINGS (BOTH ROADWAYS AND DRIVEWAYS) WILL HAVE MINIMUM MID-SPAN HEIGHT OF 18'-0".

ALL OTHER PROPOSED AERIAL CATV WILL HAVE MINIMUM MID-SPAN HEIGHT OF 16'-6" AS PER NESC SPECIFICATIONS.

NOTIFICATIONS TO ALL UTILITIES INVOLVED WILL BE MADE PRIOR TO CONSTRUCTION.

LEGEND			
✕	POWER POLE	—	BORE
⊗	POWER TRANSFORMER POLE	—	SWALE/DITCH
⊗	JOINT USE TRANSFORMER POLE	—	GUARD RAIL
○	PHONE POLE	—	FENCE LINE
●	CATV POLE	—	PROPOSED OVERHEAD CATV
⊙	STEEL POLE	—	PROPOSED BURIED CATV
⊙	CONCRETE POLE	—	EXISTING OVERHEAD CATV
⊗	JOINT USE POLE	—	EXISTING BURIED CATV
Ⓡ	RISER	—	OVERHEAD ELECTRIC
Ⓡ	ANCHOR	—	BURIED ELECTRIC
	OVERHEAD GUY	—	GAS
∇	CATV FIBER VAULT	—	OVERHEAD TELEPHONE
⊞	TRAFFIC SIGNAL VAULT	—	BURIED TELEPHONE
⊞	TRAFFIC SIGNAL POLE	—	SANITARY SEWER
⊞	TRAFFIC SIGNAL BOX	—	STORM SEWER
⊙	CROSS SECTION REFERENCE	—	WATER
???	AERIAL FOOTAGE	—	CENTERLINE
???	U/G FOOTAGE	—	EDGE OF PAVEMENT
/	REFERENCE POINT	—	BACK OF CURB
▨	STORM DRAIN	—	RIGHT OF WAY

USE CASE 1 M.O.T.

429 NW YATES LOOP
 COUNTY PERMIT
 M.O.T. CASE #601

BINDING SPACE

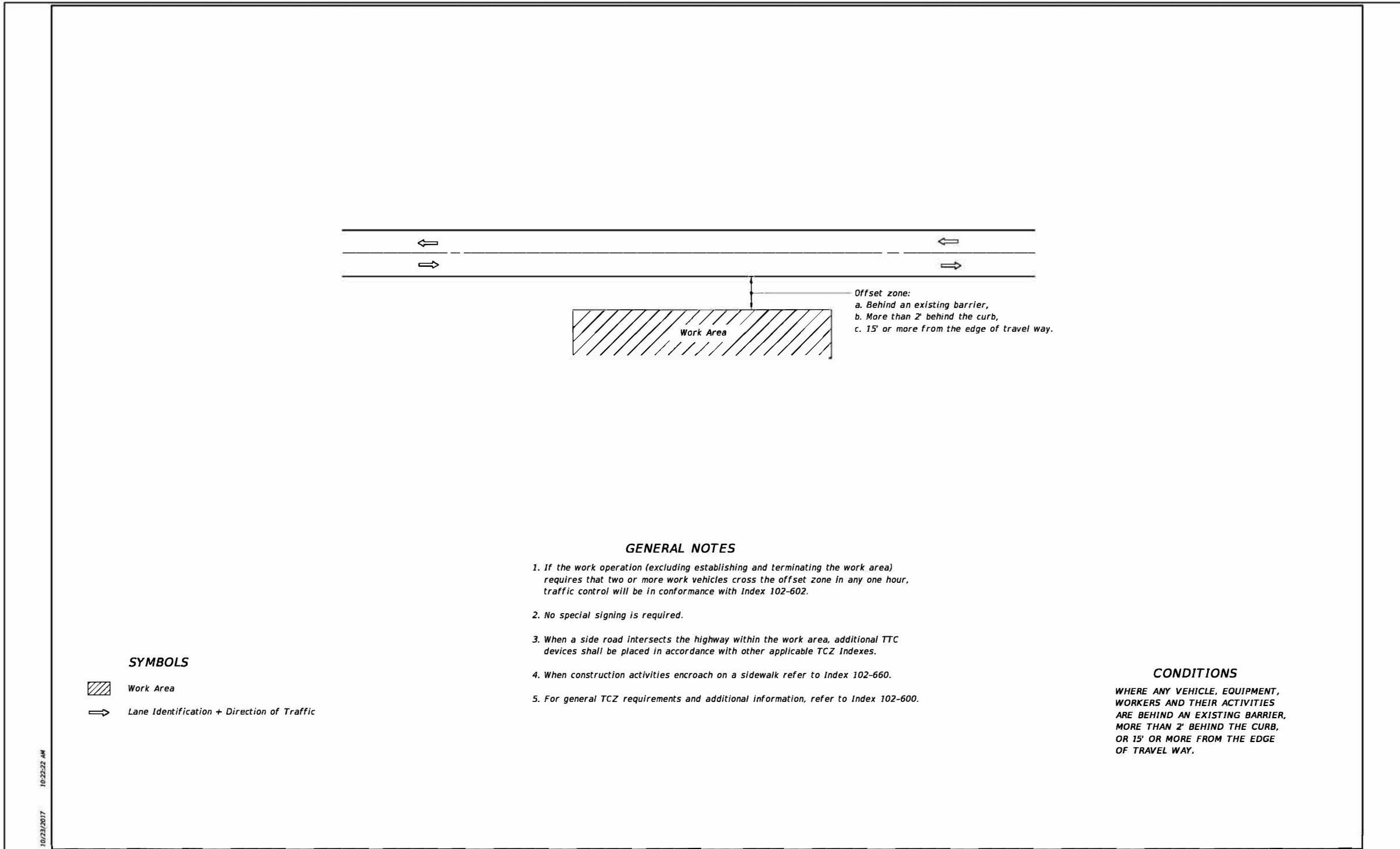

GENERAL NOTES

1. If the work operation (excluding establishing and terminating the work area) requires that two or more work vehicles cross the offset zone in any one hour, traffic control will be in conformance with Index 102-602.
2. No special signing is required.
3. When a side road intersects the highway within the work area, additional TTC devices shall be placed in accordance with other applicable TCZ Indexes.
4. When construction activities encroach on a sidewalk refer to Index 102-660.
5. For general TCZ requirements and additional information, refer to Index 102-600.

SYMBOLS

- Work Area
- Lane Identification + Direction of Traffic

CONDITIONS

WHERE ANY VEHICLE, EQUIPMENT, WORKERS AND THEIR ACTIVITIES ARE BEHIND AN EXISTING BARRIER, MORE THAN 2' BEHIND THE CURB, OR 15' OR MORE FROM THE EDGE OF TRAVEL WAY.

10/23/2017 10:22:52 AM

LAST REVISION 11/01/17	DESCRIPTION:	FY 2018-19 STANDARD PLANS	TWO-LANE, TWO-WAY, WORK OUTSIDE SHOULDER	INDEX 102-601	SHEET 1 of 1
---------------------------	--------------	-------------------------------------	---	------------------	-----------------

429 NW YATES LOOP



**COLUMBIA COUNTY, FL
 RIGHT-OF-WAY PERMIT**

SUBJECT: PROPOSED AERIAL CATV FACILITIES ON NW YATES LOOP	COUNTY:	COLUMBIA
	STATE:	FLORIDA
CIFA: N/A	SHEET NO.:	3 OF 4
	DATE:	01/25/2019
	MAP:	N/A
		DRAFTED BY: K. SANTANA

**4 . NW YATES LOOP
COUNTY PERMIT
PLAN VIEW**

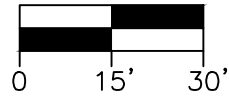

BINDING SPACE

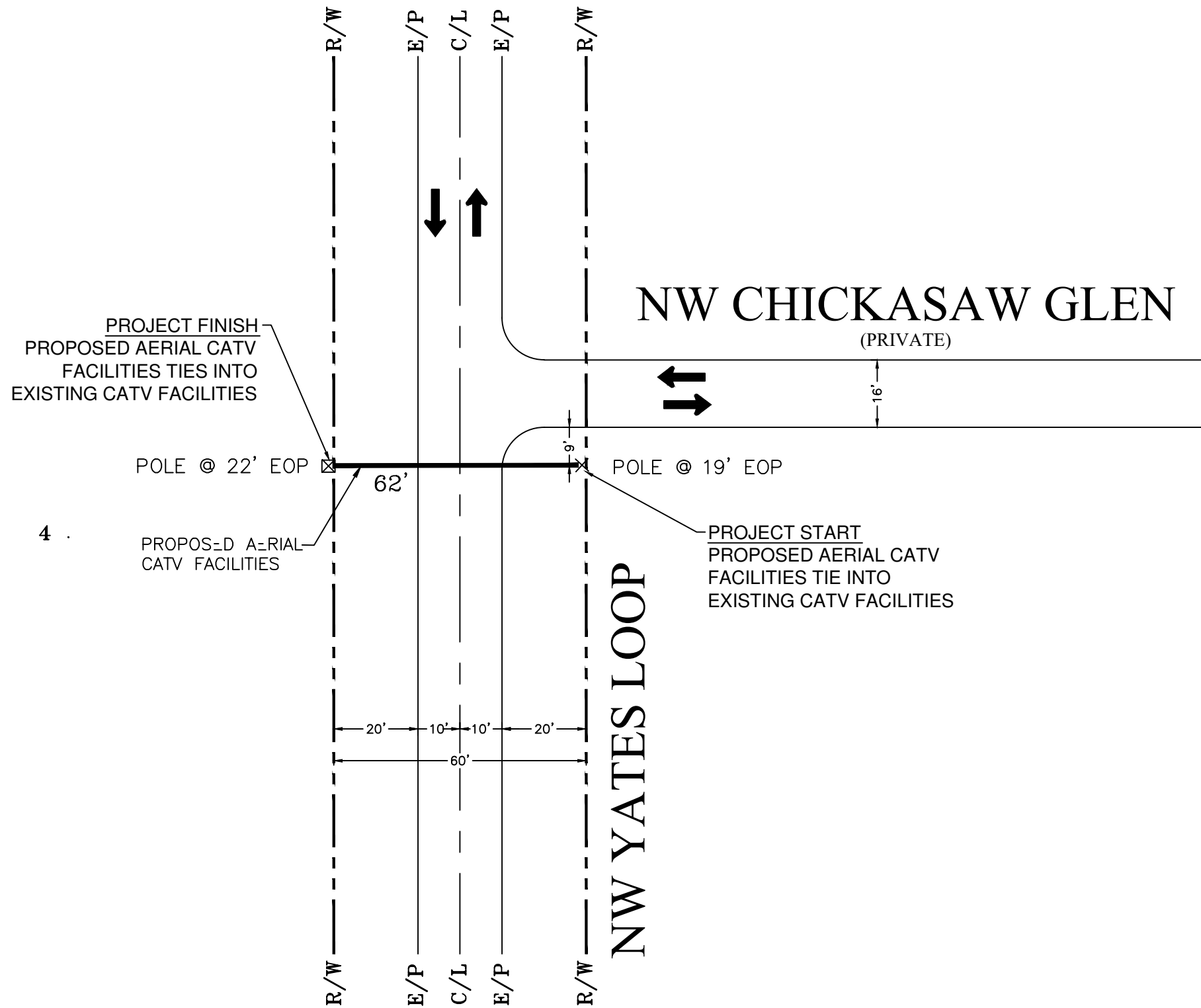

**COLUMBIA COUNTY, FL
RIGHT-OF-WAY PERMIT**

SUBJECT: 429 NW YATES LOOP		COUNTY.	IA
PROPOSED RIGHTS OF WAY	- TV - T-S	TATE.	- \IDA
LOOP		HEET NO .	4 0-
		DATE	/25/2019
CL -:		MAP.	N/A
N/-		DRAFTED BY.	K. SANTANA



**COLUMBIA COUNTY BOARD OF COUNTY COMMISSIONERS
AGENDA ITEM REQUEST FORM**

The Board of County Commissioners meets the 1st and 3rd Thursday of each month at 5:30 p.m. in the Columbia County School Board Administrative Complex Auditorium, 372 West Duval Street, Lake City, Florida 32055. All agenda items are due in the Board's office one week prior to the meeting date.

Today's Date: 3/7/2019 Meeting Date: 3/21/2019

Name: Kevin Kirby Department: Public Works

Division Manager's Signature: 

1. Nature and purpose of agenda item:

Utility Permit from Windstream for Stephen Foster

2. Recommended Motion/Action:

Approve

3. Fiscal impact on current budget.

This item has no effect on the current budget.

**COLUMBIA COUNTY BOARD OF COUNTY COMMISSIONERS
UTILITY PERMIT**

(●SP-12490 / WHSP 704792066)

Date: 2/27/2019 Permit No. _____ County Road Stephen of _____ Section No. _____

Permittee Windsream Florida, LLC
ATTN: PERMITS

Address: 4001 N. Rodney Parham Rd, B3E3 Little Rock, AR 72212 Telephone Number 501-748-8641

Requesting permission from Columbia County, Florida, hereinafter called the County, to contract, operate and maintain _____ Windsream is proposing to place approx 3,500 feet of buried 48 fiber along the right of way of NW Stephen Foster Dr beginning at NW White Spring Ave and ending at Suwannee Valley Resort in our White Springs exchange. This cable will be placed at least 36 inches deep. See location map and drawing attached.

FROM: NW White Springs Ave TO: NW Plantation Rd

Submitted for the Utility Owner by: Deanna L. Phillips - Coordinator Deanna L. Phillips 2/27/19
Typed Name & Title Signature Date

1. Permittee declares that prior to filing this application it has determined the location of all existing utilities, both aerial and underground and the accurate locations are show on the plans attached hereto and made a part of this application. Proposed work is within corporate limits of Municipality: YES () NO (X). IF YES: LAKE CITY () FORT WHITE (). A letter of notification was mailed on _____ to the following utility owners Suwannee Valley Electric

2. The Columbia County Public Works Director shall be notified twenty-four (24) hours prior to starting work and again immediately upon completion of work. The Public Works Director is Kevin Kirby located at Lake City Telephone Number 386-752-5955. The PERMITTEE's employee responsible for Maintenance of Traffic is TRAWICK CONSTRUCTION Telephone Number 866-958-7420 (This name may be provided at the time of the 24 hour notice to starting work.)

3. This PERMITTEE shall commence actual construction in good faith within 60 days after issuance of permit, and shall be completed within 30 days after permitted work has begun. If the beginning date is more than 60 days from date of permit approval, then PERMITTEE must review the permit with the Columbia County Public Works Director to make sure no changes have occurred in the transportation facility that would affect the permitted construction.

4. The construction and maintenance of such utility shall not interfere with the property and rights of a prior PERMITTEE.

5. It is expressly stipulated that this permit is a license for permissive use only and that the placing of utilities upon public property pursuant to this permit shall not operate to create or vest property right in said holder.

6. Pursuant to Section 337.403(1), Florida Statutes, whenever necessary for the construction, repair, improvement, maintenance, safe and efficient operation, alteration or relocation of all, or any portion of said transportation facility

as determined by the Columbia County Public Works Director and/or County Engineer, any or all utilities and appurtenances authorized hereunder, shall be immediately removed from said transportation facility or reset or relocated thereon as required by the Columbia County Public Works Director and/or County Engineer and at the expense of the PERMITTEE.

7. In case of non-compliance with the County's requirements in effect as of the approval date of the permit, this permit is void and the facility will have to be brought into compliance or removed from the right of way at no cost to the County.

8. It is understood and agreed that the rights and privileges herein set out are granted only to the extent of the County's right, title and interest in the land to be entered upon and used by the PERMITTEE, and the PERMITTEE will, at all times, and to the extent permitted by law, assume all risk of and indemnify, defend, and save harmless Columbia County, Florida from any and all loss, damage, cost or expense arising in any manner on account of the exercise or attempted exercise by said PERMITTEE of the aforesaid right and privileges.

9. During construction, all safety regulations of the County shall be observed and the PERMITTEE must take measures, including placing and the display of safety devices that may be necessary in order to safely conduct the public through the project area in accordance with the Federal Manual on Uniform Traffic Control Devices, as amended for highways.

10. Should the PERMITTEE be desirous of keeping its utilities in place and out of service, the PERMITTEE, by execution of this permit acknowledges its present and continuing ownership of its utilities located between _____ and _____ within the County's right of way as set forth above. PERMITTEE, at its sole expense, shall promptly remove said out of service utilities whenever Columbia County Public Works Director and/or County Engineer determines said removal is in the public interest.

11. Special instructions: Minimum cover of thirty inches (30") will be required at all locations. Columbia County will not be financially responsible for any damage to facilities with less than thirty inch (30") cover. Cables shall not be located within driveway ditches.

12. Additional Stipulations: _____

It is understood and agreed that commencement by the PERMITTEE is acknowledgment and acceptance of the binding nature of these special instructions.

Submitted By: Windstream Florida, LLC
Permittee

Deanna R. Phillips / Coordinator
Signature and Title

Place Corporate Seal

Attested Krus May



Utilities Permit
Page Three
Revised: 6/22/01

Recommended for Approval:

Signature:  _____

Title : _____ Assistant County Manager

Date : _____ 3-7-19

Approval by Board of County Commissioners, Columbia County Florida

YES () NO ()

Date Approved: _____

Chairman's Signature: _____



SEE SHEET 2

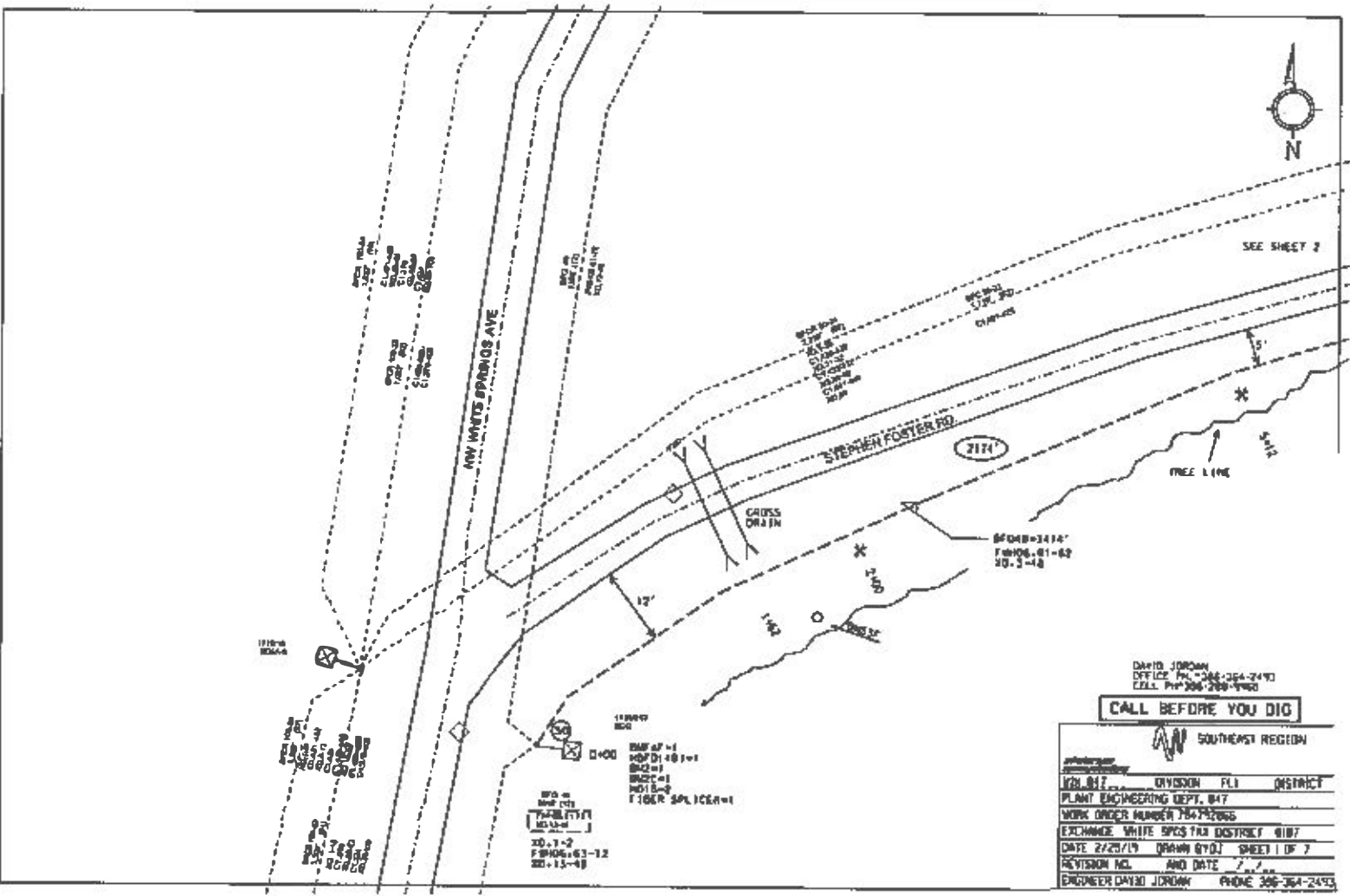

DAVID JORDAN
OFFICE PH. 306-364-2493
CELL PH. 306-208-4960

CALL BEFORE YOU DIG

 SOUTHEAST REGION

JOB NO.	015000	FL1	DISTRICT
PLANT ENGINEERING DEPT.	847		
WORK ORDER NUMBER	75472066		
EXCHANGE WHITE SPOTS FOR DISTRICT	0107		
DATE	2/20/19	DRAWN BY	DJ
REVISION NO.	AND DATE	7, 7	
ENGINEER	DAVID JORDAN	PHONE	306-364-2493



SEE SHEET 1

SEE SHEET 5

WATER POINT



8708-23
118' 00"
C1 0974.00

8708 10 24
L 207' 00"
C1 118' 00"
C1 0974.00
C1 0974.00
W 207' 00"
C1 0974.00
20 00'

STEPHEN FOSTER RD

31+0

8708-3414'
F 1006.51-42
L D. 3-48

TREE LINE

3'

8708-3414'

13+22

DAVID JORDAN
OFFICE PH. 386-364-3440
CELL. PH. 386-288-3925

CALL BEFORE YOU DIG

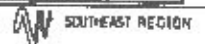

WIN 847	DIVISION FL1	DISTRICT
PLANT ENGINEERING DEPT. 847		
WORK ORDER NUMBER 78472866		
EXCHANGE WHITE SPGSTAR DISTRICT 8187		
DATE 2/25/19 DRAWN BY DJ SHEET 2 OF 7		
REVISION NO. AND DATE		
ENGINEER DAVID JORDAN		PHONE 386-364-2440

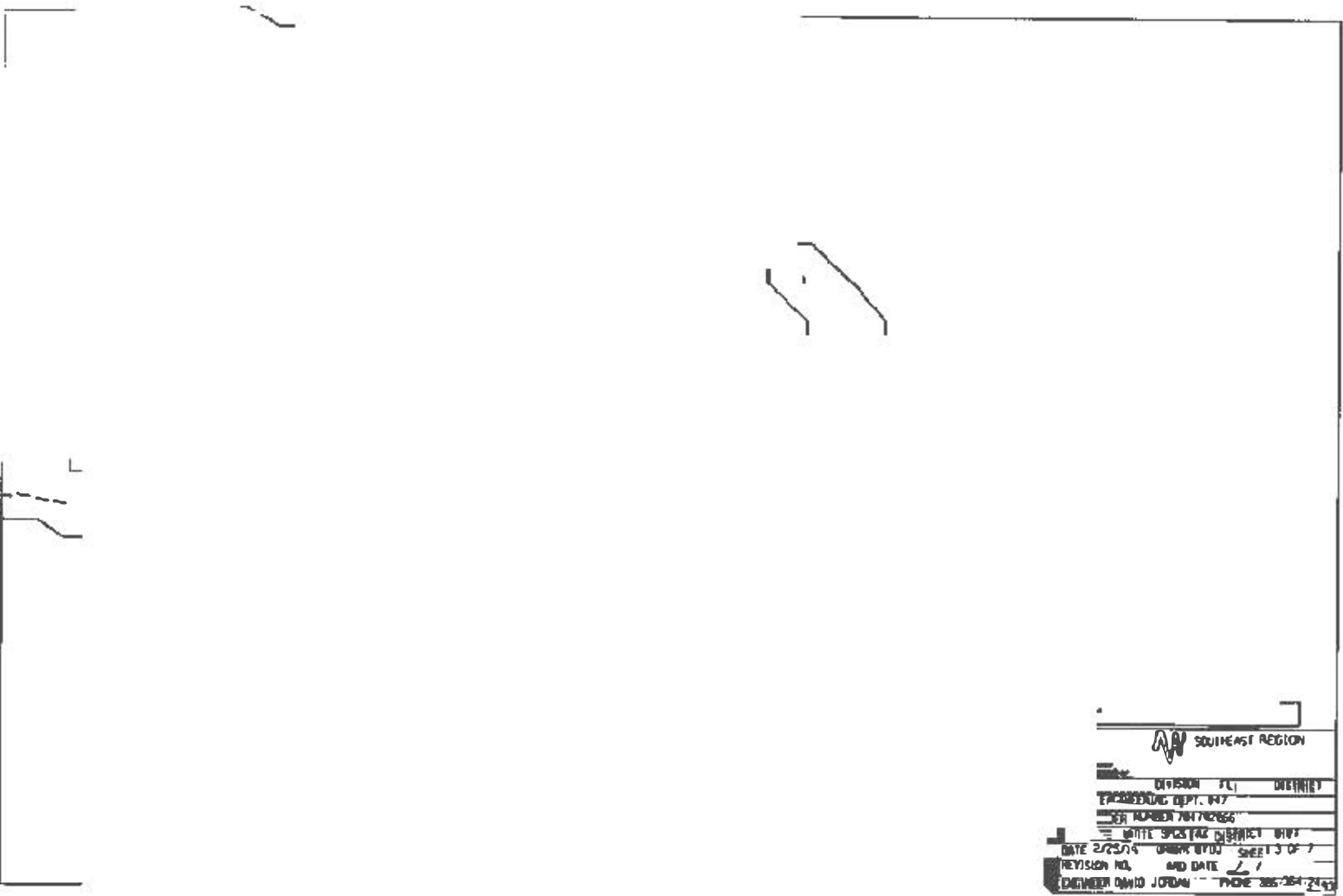

 SOUTHEAST REGION	
DIVISION (FL)	DISTRICT
ENGINEERING DEPT. 147	
JOB NUMBER 70472666	
WHITE SPACES DISTRICT 0101	
DATE 2/25/14	SHEET 3 OF 7
REVISION NO.	AND DATE
ENGINEER DAVID JORDAN	PHONE 385-354-2143

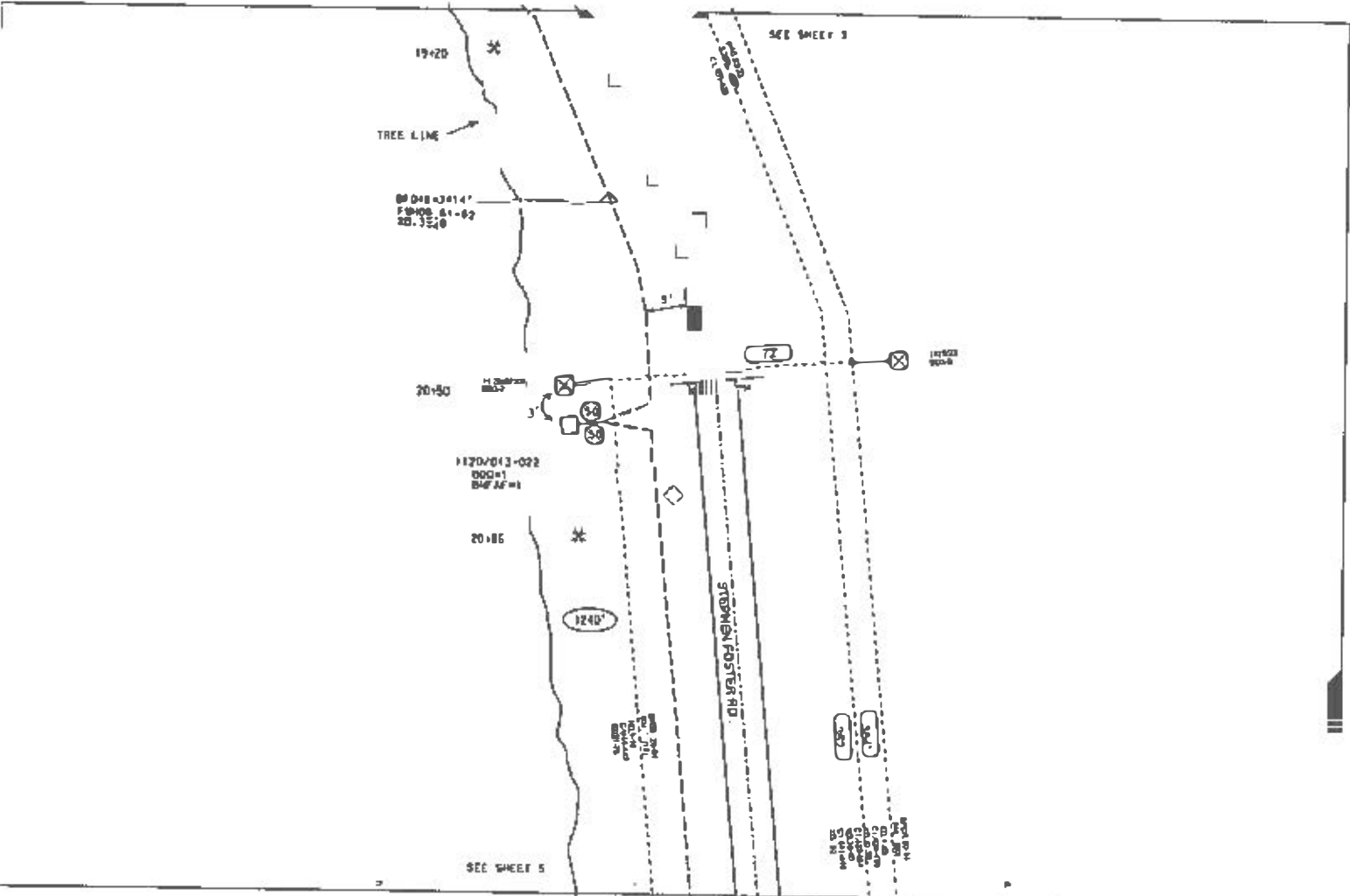

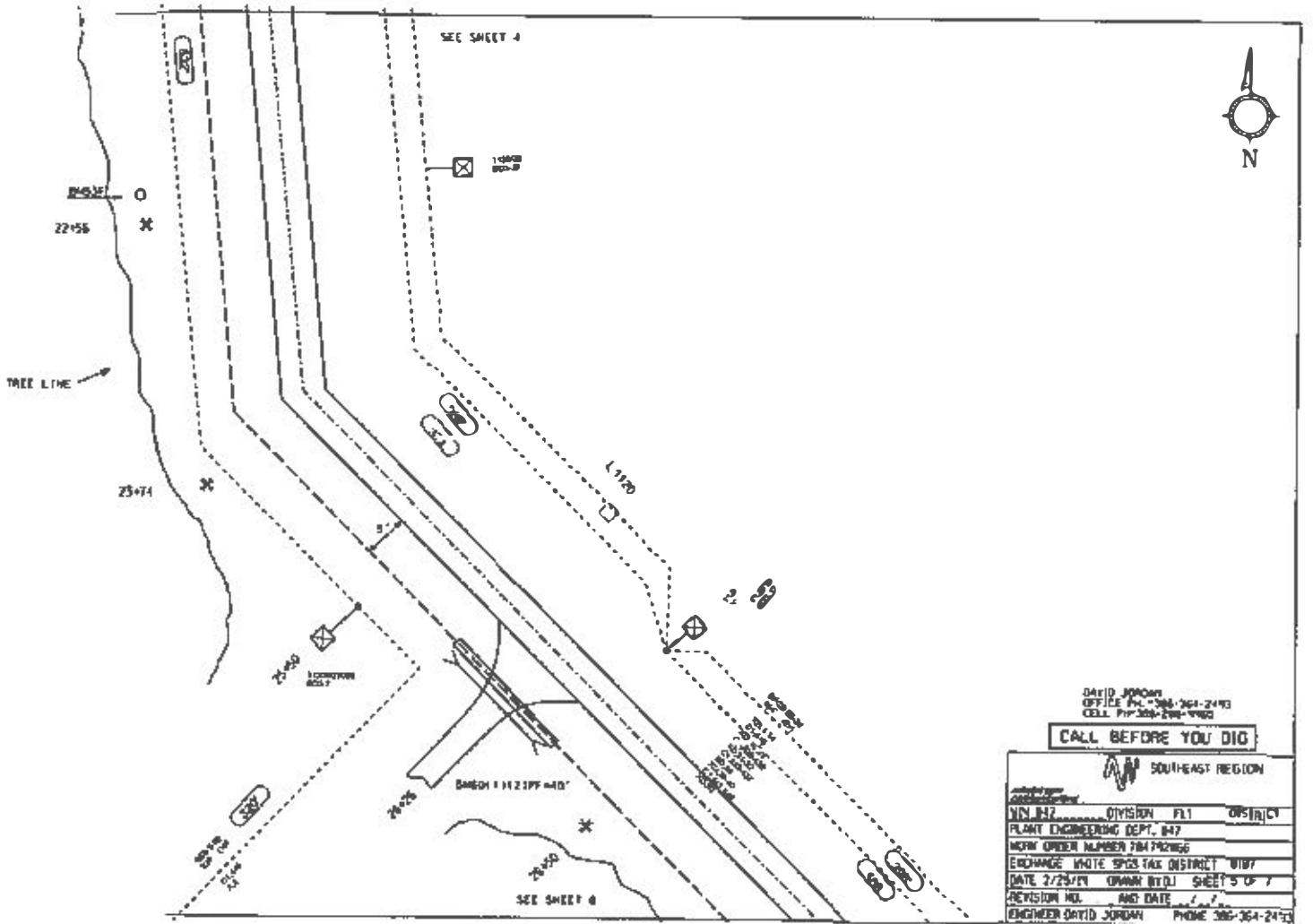

DAVID JORDAN
 OFFICE PH. 364-264-2493
 CELL PH. 364-298-9980
CALL BEFORE YOU DIG
 SOUTHEAST REGION
 PROJECT NO. 0000000000
 DIVISION F11 OSTRICH
 PLANT ENGINEERING DEPT. 047
 WORK ORDER NUMBER 704 192066
 EXCHANGE WHOLE SPDS TAX DISTRICT 0107
 DATE 2/25/11 DRAWN BY DJL SHEET 5 OF 7
 REVISION NO. AND DATE
 ENGINEER DAVID JORDAN PHONE 364-264-2493

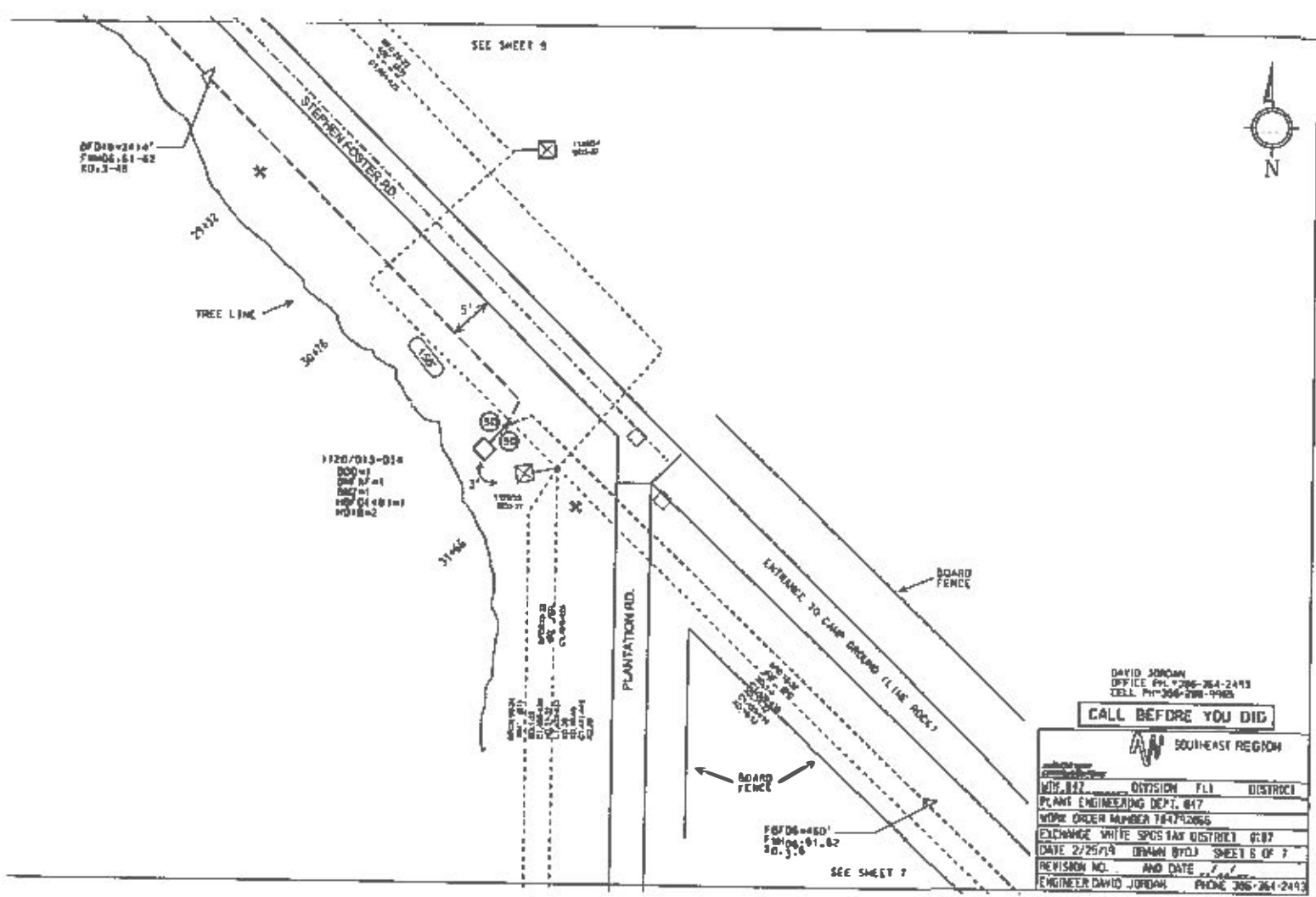

DAVID JORDAN
 OFFICE PH: 306-264-2493
 CELL: PH: 306-298-9985

CALL BEFORE YOU DIG



SEVENTH DISTRICT		
WITH #42	DIVISION FL3	DISTRICT
PLANT ENGINEERING DEPT. 847		
WORK ORDER NUMBER 784742866		
EXCHANGE WHITE SPOTS TAX DISTRICT 0187		
DATE 2/25/19 DRAWN BY(D) SHEET 8 OF 7		
REVISION NO.	AND DATE	
ENGINEER DAVID JORDAN PHONE 306-264-2493		



BEE SHEET B

BOARD FENCE

FWD61=50'
FW106.61-62
SD.3-6

GATE

FWD61=100'
FW106.61-62
RD.3-6

POLE
STRONG
W/ 25
2500

CONDUIT PROVIDED BY CUSTOMER

ELL= STOP LOG
LAT 30.318036
LON -82.750189
11207093-040
GMSF=1
DPT=1
HQ106



SUWANNEE VALLEY RESORT
CONTACT MATT HUBERT
(540) 219-2122
(813) 300-4088

786 N. STEPHEN FOSTER DR
WHITE SPRINGS, FL 32096

CKT# IP/L2XX/1064779/WINS
FW106.61-62

PLANTATION RD.

100

150

1.1' diameter
into 2"

DIVISION	FLC	DISTRICT					
ENG DEPT, 847							
WORK ORDER NUMBER 714752166							
WHITE SPRINGS DISTRICT 017							
DATE	2/25/19	DRAWN BY	SDJ	SHEET	7	OF	7
REVISION	ALL	AND	DATE	/	/		
ENGINEER	(DATE)	JORDAN	PHONE	306-351-2143			

WHSP 704792066



**WORK LOCATION ALONG
NW STEPHEN FOSTER DR
BETWEEN NW WHITE
SPRINGS AVE & NW
PLANTATION RD.**

 **Suwannee Valley Resort**



**COLUMBIA COUNTY BOARD OF COUNTY COMMISSIONERS
AGENDA ITEM REQUEST FORM**

The Board of County Commissioners meets the 1st and 3rd Thursday of each month at 5:30 p.m. in the Columbia County School Board Administrative Complex Auditorium, 372 West Duval Street, Lake City, Florida 32055. All agenda items are due in the Board's office one week prior to the meeting date.

Today's Date: 3/13/2019 Meeting Date: 3/21/2019

Name: Ray Hill Department: Purchasing

Division Manager's Signature: *Ben Scott*

1. Nature and purpose of agenda item:

Approve Disposal of Various County Assets

2. Recommended Motion/Action:

Approve Disposal

3. Fiscal impact on current budget.

This item has no effect on the current budget.

District No. 1 - Ronald Williams
District No. 2 - Rocky Ford
District No. 3 - Bucky Nash
District No. 4 - Toby Witt
District No. 5 - Tim Murphy



BOARD OF COUNTY COMMISSIONERS • COLUMBIA COUNTY

MEMORANDUM

TO: Board of Commissioners
FR: Ray Hill, Purchasing Director *C Ray Hill*
DATE: March 13, 2019
RE: Asset Disposal

Please review and approve disposal of the attached list of assets from various County Departments.

BOARD MEETS FIRST AND THIRD THURSDAY AT 5:30 P.M.

P.O. BOX 1529

LAKE CITY, FLORIDA 32056-1529

PHONE (386) 755-4100

Disposal Requests

Date: 3/21/2019

911

Asset Tag	Description	Serial	Date Aquired	Disposal Method	Cost
00013782	COMPUTER	J7LHNL1	3/29/2010	JUNK	\$1,039.00
<i>Notes: Surplus junk</i>					
00013882	ALARM PANEL	PCSA	8/23/2010	JUNK	\$2,300.00
<i>Notes: No longer in use junk</i>					
00013883	ALARM PANEL	PCSB	8/23/2010	JUNK	\$2,300.00
<i>Notes: No longer in use junk</i>					
00013884	MODEM	60236012490917	8/23/2010	JUNK	\$722.00
<i>Notes: No longer in use junk</i>					
00013885	MODEM	602630508490928	8/23/2010	JUNK	\$722.00
<i>Notes: No longer in use junk</i>					
00013886	FIREWALL	SWEK25755PKZHJ99	8/23/2010	JUNK	\$2,659.00
<i>Notes: No longer in use outdated junk</i>					
00013887	FIREWALL	SW9U2FQ8SW7PX585	8/23/2010	JUNK	\$2,659.00
<i>Notes: No longer in use outdated junk</i>					
00013888	KVM SWITCH	973908923883	8/23/2010	JUNK	\$508.00
<i>Notes: No longer in use outdated junk</i>					
00013889	KVM SWITCH	973908923943	8/23/2010	JUNK	\$508.00
<i>Notes: No longer in use outdated junk</i>					
00013929	COMPUTER	2AU0230V24	9/8/2010	JUNK	\$1,807.00
<i>Notes: No longer in use outdated computer junk</i>					
00013943	COMPUTER	2UAO230V1S	8/23/2010	JUNK	\$1,807.00
<i>Notes: Not used surplus outdated computer</i>					
00013944	COMPUTER	2UAO230V22	8/23/2010	JUNK	\$1,807.00
<i>Notes: Outdated computer junk</i>					
00013945	COMPUTER	2UAO230V1P	8/23/2010	JUNK	\$1,807.00
<i>Notes: Outdated computer junk</i>					
00013939	COMPUTER	MX20220085	8/23/2010	SALE	\$2,014.00

Notes:

00013349	DELL PE R510 SERVER	HTTX5L1	11/9/2009	SALE	\$3,462.00
----------	---------------------	---------	-----------	------	------------

Notes: Old server being replaced has internal issues

911

Total: \$26,121.00

BCC

Asset Tag	Description	Serial	Date Aquired	Disposal Method	Cost
00013064	CISCO SWITCH 1ST FLOOR TELCO ROOM	FOC11O8253D	4/20/2007	SALE	\$629.00

Notes:

00013102	COMPUTER - JARED FINANCE	69WVYC1	5/21/2007	SALE	\$881.00
----------	--------------------------	---------	-----------	------	----------

Notes:

00013037	COMPUTER TODDS	7V8PYC1	5/17/2007	SALE	\$2,049.00
----------	----------------	---------	-----------	------	------------

Notes:

00013708	COMPUTER SERVER TODD	5GSCNK1	7/31/2009	SALE	\$5,235.00
----------	----------------------	---------	-----------	------	------------

Notes:

00013736	PRINTER FINANCE	15455DN1793LWK6	11/11/2009	SALE	\$1,232.00
----------	-----------------	-----------------	------------	------	------------

Notes:

00013328	SCANNER	Q3071000076	3/28/2008	SALE	\$6,735.00
----------	---------	-------------	-----------	------	------------

Notes:

00013734	SERVER	D2VT5L1	10/23/2009	SALE	\$3,296.00
----------	--------	---------	------------	------	------------

Notes: server room rack

00012937	COMPUTER TODD	VEAG390020	11/7/2006	SALE	\$4,844.00
----------	---------------	------------	-----------	------	------------

Notes: server room spare

00014008	WEB FILTER	BARTF284180	8/2/2011	SALE	\$4,467.00
----------	------------	-------------	----------	------	------------

Notes: server room spare

00012434	COMPUTER LAP TOP TODDS	27426049417	1/6/2005	SALE	\$2,073.00
----------	------------------------	-------------	----------	------	------------

Notes: server room spare

00013720	COMPUTER SERVER	9VQM6K1	5/28/2009	SALE	\$5,291.00
----------	-----------------	---------	-----------	------	------------

Notes: server room spare

00013815	SERVER	9MOSSM1	6/3/2010	SALE	\$3,939.00
----------	--------	---------	----------	------	------------

Notes: server room spare

00014535	EQUAL LOGIC	83NDBZ1	11/26/2013	SALE	\$23,136.75
----------	-------------	---------	------------	------	-------------

Notes: server room spare

00013419	COMPUTER POWEREDGE	SBDKCG1	5/30/2008	SALE	\$3,265.00
----------	--------------------	---------	-----------	------	------------

Notes: server room spare

00013735	SONICWALL BACKUP BCC SERVER ROOM	00NC52E6766	11/11/2009	SALE	\$6,814.23
----------	-------------------------------------	-------------	------------	------	------------

Notes: server room spare

00013973	BELKIN KM SWITCH	SJS1020290500	10/5/2010	SALE	\$1,606.00
----------	------------------	---------------	-----------	------	------------

Notes: server room spare

BCC	Total: \$75,492.98
------------	---------------------------

BUILDING & ZONING

Asset Tag	Description	Serial	Date Aquired	Disposal Method	Cost
00013123	PRINTER SCANNER	DK716D301B	7/9/2007	SALE	\$17,804.00

Notes: REPLACED WITH A NEW MODEL

BUILDING & ZONING	Total: \$17,804.00
------------------------------	---------------------------

CCPHU HEALTH DEPT

Asset Tag	Description	Serial	Date Aquired	Disposal Method	Cost
00012160	PRINTER ROOM 135	5JPGGR08240	1/1/2000	JUNK	\$657.00

Notes: Does not work

00012669	PRINTER ROOM #136	CNDX05090	10/11/2005	JUNK	\$835.00
----------	-------------------	-----------	------------	------	----------

Notes: does not work

00011597	LASER JET PRINTER EH	USBGG10460	5/1/2001	JUNK	\$717.00
----------	----------------------	------------	----------	------	----------

Notes: does not work

00010782	LASER JET PRINTER EH - BEN	USGZ109074	4/1/2000	JUNK	\$558.00
----------	----------------------------	------------	----------	------	----------

Notes: does not work

00013260	COMPUTER - ROOM 144 (SPARE)	87GSGF1	1/1/2010	JUNK	\$1,395.00
----------	--------------------------------	---------	----------	------	------------

Notes: no longer in service

00014418	SERVER (IT)	9NQXHX1	7/15/2013	JUNK	\$6,662.00
----------	-------------	---------	-----------	------	------------

Notes: does not work

00012274	COMPUTER SERVER E.H. B-15	CD9B141	1/20/2004	JUNK	\$4,922.00
----------	---------------------------	---------	-----------	------	------------

Notes: no longer in service

00013186	COMPUTER - R TAYLOR	CTHRHD1	8/27/2007	JUNK	\$1,107.00
----------	---------------------	---------	-----------	------	------------

Notes: no longer in service

00013989	COMPUTER DENTAL	1NWOFN1	6/10/2010	JUNK	\$785.00
----------	-----------------	---------	-----------	------	----------

Notes: no longer in service

00013994	COMPUTER - CLINIC (ROOM 135)	5NW0FN1	6/10/2010	JUNK	\$785.00
----------	------------------------------	---------	-----------	------	----------

Notes: no longer in service

00013909	LAPTOP COMPUTER (IT)	8MBHYXTQWC	6/10/2010	JUNK	\$1,028.00
----------	----------------------	------------	-----------	------	------------

Notes: no longer in service

00013138	COMPUTER LAPTOP IT #144	CXY2XD1	10/19/2007	JUNK	\$1,408.00
----------	-------------------------	---------	------------	------	------------

Notes: no longer in service

CCPHU HEALTH DEPT Total: \$20,859.00

CLERK OF CIRCUIT COURT

Asset Tag	Description	Serial	Date Aquired	Disposal Method	Cost
00013287	READER SCANNER	33010705	4/2/2013	JUNK	\$3,421.00

Notes:

CLERK OF CIRCUIT COURT Total: \$3,421.00

GRADED ROADS

Asset Tag	Description	Serial	Date Aquired	Disposal Method	Cost
00014922	2016 DODGE RAM 1500 TRUCK, WHITE	3C6JR6AG8GG315666	7/5/2016	LOSS	\$19,487.00

Notes: Totaled in a wreck

00014244	GRADER #12	M9C00323	5/6/2013	SALE	\$199,061.00
----------	------------	----------	----------	------	--------------

Notes: TRADED IN

00014245	GRADER #58	M9C00316	5/6/2013	SALE	\$199,061.00
----------	------------	----------	----------	------	--------------

Notes: TRADED

00014246	GRADER #13	M9C00285	5/6/2013	SALE	\$199,061.00
----------	------------	----------	----------	------	--------------

Notes: TRADED

GRADED ROADS Total: \$616,670.00

LANDFILL

Asset Tag	Description	Serial	Date Aquired	Disposal Method	Cost
00011190	KNUCKLE BOOM TRK #441	2FZAAMBV51AJ04493	2/1/2001	SALE	\$76,681.00

Notes: 17 years old / 126,661 miles Has been replaced 9/28/2018

00008658	12 HP AIR COMPRESSOR SERV TRK #442	100693L939392	11/1/1993	SALE	\$1,440.00
----------	------------------------------------	---------------	-----------	------	------------

Notes: 25 years old, Has been replaced 9/11/2018

00007344 6 INCH PUMP TRK ASSEMBLY 961973 6/1/1991 SALE \$15,535.00
#423

Notes: 27 years old / Has been replaced 1/9/2018

LANDFILL Total: \$93,656.00

MAINTENANCE

Asset Tag	Description	Serial	Date Aquired	Disposal Method	Cost
00012185	ICE MACHINE MASON CITY	L212135662	3/1/2000	JUNK	\$2,029.00

Notes: ice machine no longer repairable, have replaced allready

00014130 ICE MACHINE - MAINT. 12061280010635 10/12/2012 JUNK \$1,469.00
WATERTOWN

Notes: ice machine no longer repairable

00010336 TRUCK PICKUP 1/2 TON #203 1GCEC14V4XZ199116 6/1/1999 DONATION \$15,832.00

Notes: this item being donated to the Lake City Animal Shelter

MAINTENANCE Total: \$19,330.00

MOSQUITO CONTROL

Asset Tag	Description	Serial	Date Aquired	Disposal Method	Cost
00010939	2000 GMC MOSQUITO PU TRUCK #417	1GTCS14W1Y890643	2/1/2000	SALE	\$11,639.00

Notes: 18 years old/ 113,122 miles Transmission problems

MOSQUITO CONTROL Total: \$11,639.00

PROPERTY APPRAISER

Asset Tag	Description	Serial	Date Aquired	Disposal Method	Cost
00010993	DIGITAL CAMERA - JERRY	UNK	8/1/2000	JUNK	\$623.00

Notes: very old digital camera

00009960 LATERAL FILE CABINET MAP ROOM UNK 9/1/1997 JUNK \$750.00

Notes:

00011843 5 DRAWER FILE UNIT - WANDA 4998SIK 10/1/2001 JUNK \$833.00

Notes:

00013565 SAFECO FLAT FILE MAP ROOM 9/28/2007 JUNK \$791.00

Notes:

00013742 WORKSTATION JUDY 6/15/2009 JUNK \$769.00

Notes:

Notes:

PROPERTY APPRAISER Total: \$4,760.00

REPAIR SHOP

Asset Tag	Description	Serial	Date Aquired	Disposal Method	Cost
00011879	PICKUP TRUCK 2002 HOYLES	1GCEK14V42Z218517	12/1/2001	SALE	\$17,865.00

Notes: SOLD LONG AGO

REPAIR SHOP Total: \$17,865.00

RICHARDSON COMM. CENTER

Asset Tag	Description	Serial	Date Aquired	Disposal Method	Cost
00013623	CISCO NETWORK SWITCH	SFOC1305YOA6	2/13/2009	JUNK	\$897.00

Notes: power fault

RICHARDSON COMM. CENTER Total: \$897.00

ROAD DEPT. ADMIN.

Asset Tag	Description	Serial	Date Aquired	Disposal Method	Cost
00013844	COMPUTER ARTS	GFM2LM1	6/28/2010	SALE	\$588.00

Notes: out of date

00014085	DISTANT MEASURING INSTRUMENT	ML1206023	7/16/2012	JUNK	\$535.00
----------	------------------------------	-----------	-----------	------	----------

Notes: BROKEN

00014295	MEASURING DEVICE KEN SWEET	NL1305010	5/17/2013	JUNK	\$535.00
----------	----------------------------	-----------	-----------	------	----------

Notes: BROKEN

00013351	RADIO TRANSCEIVER OFFICE	90300095	3/24/2008	JUNK	\$1,243.00
----------	--------------------------	----------	-----------	------	------------

Notes: OUTDATED

00013353	RADIO TRANSCEIVER OFFICE	90300092	3/24/2008	JUNK	\$1,243.00
----------	--------------------------	----------	-----------	------	------------

Notes: OUTDATED

00013975	TRANSMITTER & RECEIVER	8291644	10/20/2010	JUNK	\$3,203.00
----------	------------------------	---------	------------	------	------------

Notes: OUTDATED

ROAD DEPT. ADMIN. Total: \$7,347.00

SECONDARY MAINTENANCE

Asset Tag	Description	Serial	Date Aquired	Disposal Method	Cost
00013343	MOBILE RADIO ON DT034	224123	3/4/2008	JUNK	\$750.00

Notes: OUTDATED

00013345 MOBILE RADIO ON DT032 223149 3/4/2008 JUNK \$750.00

Notes: OUTDATED

SECONDARY MAINTENANCE Total: \$1,500.00

SIGN SHOP

Asset Tag	Description	Serial	Date Aquired	Disposal Method	Cost
00014319	DISTANCE MEASURING DEVICE	ML1307014	7/26/2013	JUNK	\$535.00

Notes:

00014017 DISTANCE MEASURING MACHINE ML1206014 7/11/2012 JUNK \$535.00

Notes:

00013558 TRUCK SIGN SHOP#106 1FTRF14W19KA73244 11/4/2008 DONATION \$15,477.00

Notes: Donate to Lake City Animal Shelter.

00013559 TRUCK SIGN SHOP #105 1FTRF14W39KA73245 11/4/2008 LOSS \$15,477.00

Notes: Totaled by insurance company due to wreck. Settlement is \$4,939.00

SIGN SHOP Total: \$32,024.00

TOURIST DEVELOPMENT

Asset Tag	Description	Serial	Date Aquired	Disposal Method	Cost
00014994	MICROSOFT SURFACE BOOK (LAPTOP)	001011462557	11/14/2016	LOSS	\$1,804.05

Notes: This laptop was stolen from the Columbia County Tourist Development Council's Executive Director. She reported the theft on 5-31-18 and LCPD wrote up a report on it with the case#LCPD18OFF014396.

TOURIST DEVELOPMENT Total: \$1,804.05

TREE TRIMMING CREW

Asset Tag	Description	Serial	Date Aquired	Disposal Method	Cost
00013356	CHAIN SAW	20072500120	3/13/2008	LOSS	\$719.00

Notes: STOLEN

00013355 RADIO TRANSCEIVER #133 90300096 3/24/2008 JUNK \$1,243.00

Notes:

TREE TRIMMING CREW Total: \$1,962.00

UTILITIES - SEWER

Asset Tag	Description	Serial	Date Aquired	Disposal Method	Cost
00013354	RADIO TRANSCEIVER #61	9300099	3/24/2008	JUNK	\$1,243.00

Notes:

00014360 GENERATOR UTILITES - WATER PWS0263927
PLANT

9/11/2013 LOSS \$699.00

Notes: *stolen*

UTILITIES - SEWER Total: \$1,942.00

WEST BRANCH LIBRARY

Asset Tag	Description	Serial	Date Aquired	Disposal Method	Cost
00013874	DESKTOP COMPUTER	7OFSKN1	9/24/2010	SALE	\$800.00

Notes:

WEST BRANCH LIBRARY Total: \$800.00

Report Totals: \$955,894.03



**COLUMBIA COUNTY BOARD OF COUNTY COMMISSIONERS
AGENDA ITEM REQUEST FORM**

The Board of County Commissioners meets the 1st and 3rd Thursday of each month at 5:30 p.m. in the Columbia County School Board Administrative Complex Auditorium, 372 West Duval Street, Lake City, Florida 32055. All agenda items are due in the Board's office one week prior to the meeting date.

Today's Date: 3/11/2019 Meeting Date: 3/21/2019

Name: Alden Rosner Department: Tourist Development

Division Manager's Signature: *Ben Scott*

1. Nature and purpose of agenda item:

Advertising agreement with Sports Events Magazine - \$4,996.25

2. Recommended Motion/Action:

Approve

3. Fiscal impact on current budget.

This item is currently budgeted. The account number to be charged is 107-5290-552.30-48



971 West Duval Street, Suite 145
Post Office Box 1847
Lake City, Florida 32056-1847
(386) 758-1312
www.SpringsRUs.com

Memorandum

DATE: 3/11/2019
TO: David Kraus, Assistant County Manager
FROM: Alden Rosner, Sports Marketing Director 
RE: Advertising Expenditure Approval—\$4,996.25

The Tourist Development Department is seeking approval to enter into a sports marketing and advertising agreement with *Sports Events Magazine* in the amount of \$4,996.25. The agreement includes the following:

- Full page ad and full page advertorial (two-page spread) in May edition of Sports Events Magazine
- E-Newsletter sponsor for June
- Banner ad for July e-newsletter
- Half page ad in August edition
- E-newsletter highlight and sponsored content for September e-newsletter

Sports Events Magazine is a publication targeting sports events planners, tournament directors, national governing bodies, sports organizations, and more. The magazine has a print circulation of greater than 18,000 plus more than 6,000 e-newsletter recipients.



Insertion Order

Insertion Order Number: 2795

Customer I.D. 71370

Date: 3/8/2019

Advertiser:
 Columbia County Tourist Development Council
 P. O. Box 1847
 Lake City, FL
 (386) 719-1453
 www.springsrus.com

Ad Traffic & Materials:
 Stephanie Eckman
 Traffic Coordinator
 (251) 968-2203
 seckman@coveypubs.com

Accounting Contact:
 Mandi Morrison
 Finance Manager
 (251) 968-5304
 mmorrison@coveypubs.com

Sales Rep Contact:
 Kelsey Carpenter
 Sales Manager
 251-968-5300
 koconnor@coveypubs.com

Platform	Issue	Year	Feature	Ad Unit	Ad Material Deadline	Rate Card	Amount
SportsEvents Magazine	May	2019	Small Markets- BIG on Sports	Full Page Ad + Full Page Advertorial	4/12/2019	3,220.00	\$2,737.00
SportsEvents Magazine	Aug	2019	Annual Natural Venues Guide	1/2 Page	7/8/2019	2,205.00	\$1,874.25
Print/Event Total							\$4,611.25

Product	Month	Year	Ad Unit	Rate Card	Discount Details	Amount
SportsEvents E-Newsletter	Jun	2019	E-Newsletter Sponsor	662.00	Special Discount: 277.00	\$385.00
SportsEvents E-Newsletter	Jul	2019	Middle Banner Ad	712.00	Added Value: 712.00	\$0.00
SportsEvents E-Newsletter	Sep	2019	Sponsored Content	721.00	Added Value: 721.00	\$0.00
Digital Total						\$385.00

Total:	\$4,996.25
---------------	------------

Print Ad Requirements:

- Ads must be submitted to the exact size specifications based on the purchase unless arranged otherwise.
- High-resolution (300 dpi) JPEG or PDF files are accepted. Fonts and high-resolution images must be embedded in the PDF file
- For bleed ads, place text at least 1/2 inch inside the trim area.
- Please do not use color bars and/or crop marks.
- We cannot accept ads in Microsoft Word, Pagemaker, Publisher or other file formats no specified above.
- All costs incurred for re-sizing, editing or changing text or images will be billed back to the client.
- Any ads designed in house cannot be used outside of Covey Communications Corp.

Digital Ad Requirements:

- Ads must be submitted to the exact size specifications based on the purchase unless arranged otherwise.
- Any ads designed in house cannot be used outside of Covey Communications Corp.
- All costs incurred for re-sizing, editing or changing text or images will be billed back to the client.

Terms of Contract:

- Materials dates subject to change
- Publisher reserves the right to cancel this contract for any reason at any time without penalty.
- A 10% cancellation fee will apply to all print and digital advertising orders canceled more than (10) working days prior to the materials deadline. After that time, a cancellation fee of 30% of the total due will apply.
- A 50% space reservation fee will apply to all digital advertising orders that we do not receive materials in by the requested materials date.
- A 10% cancellation fee will apply to event sponsorships and registrations canceled more than (60) days prior to event date. After that time, a cancellation fee of 30% of the total due will apply.
- Client agrees to pay the amount due no later than 30 days from the date of invoice unless otherwise specified and approved by the publisher.

Authorization

I hereby affirm that I am authorized to contract for this purchase on behalf of the above-named company. I acknowledge this contract is subject to all terms and conditions of the publisher's current rate card which is hereby incorporated by reference herein. Payment terms: 30 days from the date of invoice unless otherwise specified and approved by the publisher.

Authorized Signature: _____ Date: _____

Sales Rep.: Kelsey Carpenter Date: 3/8/2019

Please sign and email to koconnor@coveypubs.com or fax to 251-968-5315

201

Sports Tourism Marketing Proposal

Target Audience: Sports Events Planners, Tournament Directors, National Governing Bodies, Sports Organizations & More



PRINT • DIGITAL • SOCIAL • EMAIL • FACE-TO-FACE

PREPARED FOR





SPORTS TOURISM MARKETING PACKAGE #1

	Material Deadline	Rate Card	Packaged Rate (net)
MAY: Full Page Ad + BONUS Full Page Advertorial = 2 Page Spread			
<ul style="list-style-type: none"> • Small Markets – BIG on Sports • Issue Sponsor Listing includes website and phone number • Hyperlinked Ad in the digital edition for a full year 	4/12/19	\$7,100	\$2,737
JUNE: E-Newsletter Sponsor			
<ul style="list-style-type: none"> • Hyperlinked Logo to your website of choice • Located within the <i>SportsEvents</i> monthly E-Newsletter 	5/22/19	\$662	\$385
JULY: E-Newsletter Middle Banner Ad			
<ul style="list-style-type: none"> • 728 x 90 Banner ad • Hyperlinked to your website of choice 	6/14/19	\$712	<i>Added Value</i>
AUGUST: Half Page Ad			
<ul style="list-style-type: none"> • Annual Guide to Natural Venues & Destinations • Listing within Natural Venues Guide • Issue Sponsor Listing includes website and phone number • Hyperlinked Ad in the digital edition for a full year 	7/08/19	\$2,395	\$1,874.25
SEPTEMBER: E-Newsletter Sponsored Content			
<ul style="list-style-type: none"> • Highlight Columbia County by sharing headline news or article links with the rest of the industry • Includes 30 words and hyperlink to your website of choice 	8/21/19	\$721	<i>Added Value</i>
BONUS DISTRIBUTION			
<ul style="list-style-type: none"> • Bonus Distribution of issues at S.P.O.R.T.S. Conference, NASC Symposium and other industry trade show 		\$1,000	<i>Added Value</i>
OTHER ADDED VALUE:			
<ul style="list-style-type: none"> • 24/7 Access to Online Bid Sheet, Tools, Directories, Digital Magazine and More • Preferred editorial coverage by editors throughout the year • BPA Audited Circulation Statement (Request a copy anytime) • Free Ad Design Consultation From the <i>SportsEvents</i> Design Team 		\$1,000 total	<i>Added Value</i>
		TOTAL VALUE	YOUR TOTAL
		\$13,590	\$4,996.25 net



SPORTS TOURISM MARKETING PACKAGE #2

	Material Deadline	Rate Card	Packaged Rate (net)
MAY: Half Page Ad + BONUS Half Page Advertorial = Full Page <ul style="list-style-type: none"> • Small Markets – BIG on Sports • Issue Sponsor Listing includes website and phone number • Hyperlinked Ad in the digital edition for a full year 	4/12/19	\$3,550	\$1,810.50
MAY: Leaderboard Banner Ad <ul style="list-style-type: none"> • 728 x 90 pixels Banner ad located on <i>SportsEvents</i> Homepage for full month • Hyperlinked to your website of choice 	4/19/19	\$949	Added Value
JUNE: Half Page Ad <ul style="list-style-type: none"> • Top Multi-Use Sports Complexes • Issue Sponsor Listing includes website and phone number • Hyperlinked Ad in the digital edition for a full year 	5/10/19	\$2,395	\$1,810.50
JULY: E-Newsletter E-Vertorial <ul style="list-style-type: none"> • Blend into the <i>SportsEvents</i> Newsletter by providing an announcement or piece of news related to Columbia County • Includes a high-res logo, facility, event image, or headshot • 50 words of copy + Contact Info 	6/14/19	\$875	Added Value
AUGUST: Half Page Ad <ul style="list-style-type: none"> • Annual Guide to Natural Venues & Destinations • Listing within Natural Venues Guide • Issue Sponsor Listing includes website and phone number • Hyperlinked Ad in the digital edition for a full year 	7/08/19	\$2,395	\$1,810.50
SEPTEMBER: E-Newsletter Sponsored Content <ul style="list-style-type: none"> • Highlight Columbia County by sharing headline news or article links with the rest of the industry • Includes 30 words and hyperlink to your website of choice 	8/21/19	\$721	Added Value
BONUS DISTRIBUTION			
<ul style="list-style-type: none"> • Bonus Distribution of issues at S.P.O.R.T.S. Conference, NASC Symposium and other industry trade show 		\$1,000	Added Value
OTHER ADDED VALUE:			
<ul style="list-style-type: none"> • 24/7 Access to Online Bid Sheet, Tools, Directories, Digital Magazine and More • Preferred editorial coverage by editors throughout the year • BPA Audited Circulation Statement (Request a copy anytime) • Free Ad Design Consultation From the <i>SportsEvents</i> Design Team 		\$1,000 total	Added Value
		TOTAL VALUE	YOUR TOTAL
		\$12,885	\$5,431.50 net

AUDIENCE PROFILE

SportsEvents is a B2B/Consumer brand intended for individuals with broad-based interests in Sporting Event industries. ***SportsEvents* media outlets are developed for sports event planners, national governing bodies (NGBs), rights holders and event owners.** *SportsEvents* targets youth and amateur sports events planners who travel market-to-market with their events. *SportsEvents* recipients book sites for over 41,000 annual events.

The brand content and editorial scope of the publication includes news and industry comment, in-depth articles, industry round-up and special features. The content of every issue is also available to subscribers globally via the online digital version.

CIRCULATION

- ✓ **18,000+** Total Print Circulation
- ✓ **6,000+** E-Newsletter Recipients
- ✓ **2,700+** Social Media Followers
- ✓ **250+** S.P.O.R.T.S. Conference Attendees

CIRUCLATION VERIFICATION



SportsEvents Magazine is the industries **only** publication that offers any form of third-party circulation verification.

BPA Worldwide provides an independent, third-party audit of audience claims for *SportsEvents* Magazine.



Geographical Breakout of Qualified Circulation

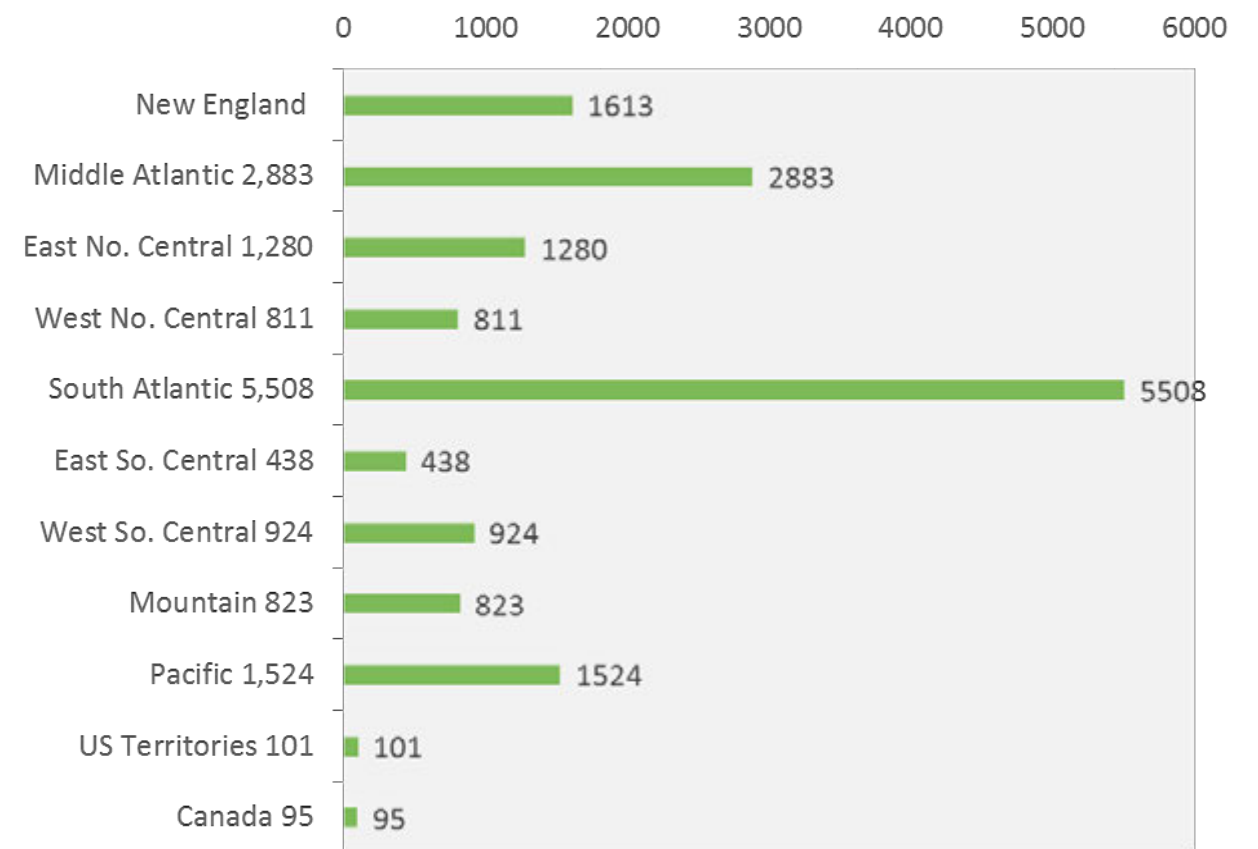

SUBSCRIBER PROFILE

FIELDS & RECIPIENTS SERVED

- Sports governing bodies (local, national, regional directors)
- Sports organizations/associations
- Sports Events Planners
- League Managers and Directors
- Executives at Sports Complexes
- Sanctioning organizations
- Sports events sponsors
- Sports commissions
- Destination marketing organizations
- Sports marketing firms
- Universities, Colleges and Junior colleges
- Professional teams
- Alumni associations
- Sports events promoters

95% of
Subscribers
are Sports
Events
Planners

SportsEvents Magazine

- 18,000+ Circulation
- 12 Issues Per Year
- 3 Annual Guides

www.SportsEventsMagazine.com

- 13,000 Annual Unique Visitors

SportsEvents Play•by•Play E-Newsletter

- 6,000 Monthly Newsletter Subscribers

Social Media

- Facebook Followers: 2,600+
- Twitter Followers: 2,000+
- LinkedIn Followers: 200+

S.P.O.R.T.S. – The Relationship Conference

- 250+ Attendees
- 1:3 Ratio (Planners to Suppliers)

SUBSCRIBER TRENDS

9 out of **10**
Sports Move
Market to
Market

Subscribers of
SportsEvents
on average
contract sites
1-2 years in
advance

Sports Events
Industry Total
Economic Impact
\$10.546
Billion

Average
Economic
Impact of
\$238,058
per event

ABOUT *SportsEvents*

SportsEvents Media Group can provide you with an integrated marketing strategy that blends all aspects of marketing communication such as advertising, sales promotion, public relations, direct marketing, face-to-face, and social media, through our multi-media channels. Each marketing package is carefully crafted for your specific needs to ensure that you achieve outstanding results with your campaign.

PRINT

- ✓ Interesting and Relevant Content for Sports Events Planners
- ✓ 18,000+ Recipients
- ✓ Industry's Only Monthly Magazine
- ✓ BPA® Audited Circulation
- ✓ Easy Access Digital E-Pub with Free Download
- ✓ Convenient Issue Sponsor Guide in Each Edition
- ✓ Bonus Distribution of Magazines at Industry Conferences
- ✓ 95% Advertiser Retention Rate

DIGITAL

- ✓ Trackable Web Ads
- ✓ Customized E-Blasts
- ✓ Destination Spotlights
- ✓ Monthly E-Newsletters to 6,000+
- ✓ Tech Tools & Online How-to Articles
- ✓ Fascinating Blog Posts
- ✓ Searchable Fields and Facilities Directories
- ✓ Up to Date Bid Sheets for the Latest Events

S.P.O.R.T.S. – THE RELATIONSHIP CONFERENCE

- ✓ Unique Reverse Trade Show Focused on Building Relationships
- ✓ Over 250 Sports Industry Experts Attend Each Year
- ✓ Over 1,200 Appointments are Made Each Year
- ✓ 60-75 Planners
- ✓ Low 1:3 (Planner to Supplier Ratio)
- ✓ 15 Minute Pre-Qualified Appointments



THANK YOU COLUMBIA COUNTY!

Our objective is to grow our partnership with Columbia County. Our job is to make sure you are connecting with sports events planners throughout the year using every available platform *SportsEvents* has to offer. Our editorial team will work hard to find unique and interesting story angles to include the area in print and online features whenever there is relevant content or comments to share. We will “post” on Facebook and “tweet” on Twitter any updates that are shared with us. We want to help build their sports brand, generate real leads, and grow tourism in Columbia County.

Thank you for the opportunity to present this to you!

Kelsey Carpenter



Covey Communications Corp.
SportsEvents Media Group
S.P.O.R.T.S. The Relationship Conference
2001 West First Street
Gulf Shores, AL 36542
www.sportseventsmagazine.com
www.therelationshipconference.com

SPORTSEVENTS CONTACTS:

Shellie Kichler | Director of Sales | (251) 968-5329 | skichler@coveypubs.com
Kelsey Carpenter | Sales Manager | (251) 968- 5330 | kcarpenter@coveypubs.com
Talty O'Connor | Owner and Publisher | toconnor@coveypubs.com
Sherri Middleton | Managing Editor | smiddleton@coveypubs.com
Carrie O'Connor | S.P.O.R.T.S. Conference Manager | (251) 968-0482 | coconnor@coveypubs.com
Amy Peebles | Marketing Coordinator | (251) 968-7023 | apeebles@coveypubs.com
Stephanie Eckman | Traffic Coordinator | (251) 968-2203 | seckman@coveypubs.com
Mandi Morrison | Finance Manager | (251) 968-5304 | mmorrison@coveypubs.com

No attempt has been made to rank the information contained in this report in order of importance, since BPA Worldwide believes this is a judgment which must be made by the user of the report.

Covey Communication Corp.
P.O. Box 2267
Gulf Shores, AL 36547
Tel. No.: (251) 968-5300
Fax No.: (251) 968-2033
www.sportseventsmagazine.com
toconnor@coveypubs.com

SPORTSEVENTS is a B2B/Consumer brand intended for individuals with broad-based interests in Sporting Event industries. The brand content and editorial scope of the publication includes news and industry comment, in-depth articles, industry round-up and special features. The content of every issue is also available to subscribers globally via the online digital version.

FIELD SERVED

SPORTSEVENTS serves sports events promoters, sports governing bodies (local, national, regional directors), sanctioning organizations, sports organizations/associations, sports events sponsors, sports commissions, sports marketing firms, universities, colleges, junior colleges, professional teams, alumni associations, destination marketing organizations, media, travel agencies, and others allied to the field.

DEFINITION OF RECIPIENT QUALIFICATION

Qualified recipients include sports event planners, league managers and directors, executives at sports complexes and other titled and non-titled personnel in the country's sports events industry.

CHANNELS

**SPORTSEVENTS
MAGAZINE**



5 issues in the period
16,910 average circulation

EXECUTIVE SUMMARY

Below are the average contacts per occurrence, including frequency per period reported

	Non-Paid	Paid	Average
SPORTSEVENTS MAGAZINE (5 issues in the period)	16,910	-	16,910

AVERAGE NON-QUALIFIED CIRCULATION

Non-Qualified Not Included Elsewhere	Copies
Other Paid Circulation	-
Advertiser and Agency	35
Allocated for Trade Shows and Conventions	260
All Other	401
TOTAL	696

1. AVERAGE QUALIFIED CIRCULATION BREAKOUT FOR PERIOD

Qualified Circulation	Total Qualified		Qualified Non-Paid		Qualified Paid	
	Copies	Percent	Copies	Percent	Copies	Percent
Individual	16,910	100.0	16,910	-	-	-
Sponsored Individually Addressed	-	-	-	-	-	-
Membership Benefit	-	-	-	-	-	-
Multi-Copy Same Addressee	-	-	-	-	-	-
Single Copy Sales	-	-	-	-	-	-
TOTAL QUALIFIED CIRCULATION	16,910	100.0	16,910	100.0	-	-

2. QUALIFIED CIRCULATION BY ISSUES FOR PERIOD

2018 Issue	Total Qualified
January	16,007
February	16,268
March/April	16,277
*May	18,000
June	18,000

***See Additional Data**

3a. BUSINESS/OCCUPATION BREAKOUT OF QUALIFIED CIRCULATION FOR ISSUE OF MAY 2018
 This issue is 8.2% or 1,362 copies above the average of the other 4 issues reported in Paragraph 2.

Business and Industry	Total Qualified	Percent of Total
Sports Event Promoters, Sports Governing Bodies (local, national, regional directors), Sanctioning Organizations, Sports Organizations/Associations, Sports Event Sponsors, Sports Commissions, Sports Marketing Firms, Universities, Colleges, Junior Colleges, Professional Teams, Alumni Associations, Destination Marketing Organizations, Media, and Travel Agencies	10,645	59.1
Others allied to the field	7,355	40.9
TOTAL QUALIFIED CIRCULATION	18,000	100.0
PERCENT	100.0	

Qualified recipients include sports event planners, league managers and directors, executives at sports complexes and other titled and non-titled personnel in the country's sports events industry.

3b. QUALIFICATION SOURCE BREAKOUT OF QUALIFIED CIRCULATION FOR ISSUE OF MAY 2018

Qualification Source	Qualified Within			Total Qualified	Percent
	1 Year	2 Years	3 Years		
I. Direct Request:	197	280	113	590	3.3
II. Request from recipient's company:	-	-	-	-	-
III. Membership Benefit:	-	-	-	-	-
IV. Communication from recipient or recipient's company (other than request):	-	-	-	-	-
V. TOTAL - Sources other than above (listed alphabetically):	14,645	2,765	-	17,410	96.7
*Association rosters and directories	3,508	1,445	-	4,953	27.5
Business directories	-	-	-	-	-
Manufacturer's, distributor's, and wholesaler's lists	-	-	-	-	-
*Other sources	11,137	1,320	-	12,457	69.2
VI. Single Copy Sales:	-	-	-	-	-
TOTAL QUALIFIED CIRCULATION	14,842	3,045	113	18,000	100.0
PERCENT	82.5	16.9	0.6	100.0	

***See Additional Data**

AVERAGE ANNUAL AUDITED QUALIFIED CIRCULATION AND CURRENT UNAUDITED CIRCULATION STATEMENTS

6-Month Period Ended:	Audited Data		Audited Data		Circulation Claim	
	July – December 2015	January – June 2016	July – December 2016	January – June 2017	July – December 2017*	January – June 2018*
Total Audit Average Qualified:	16,639	16,443	16,304	16,051	16,001	16,910
Qualified Non-Paid:	16,639	16,443	16,304	16,051	16,001	16,910
Qualified Paid:	-	-	-	-	-	-
Post Expire Copies included in Total Qualified Circulation:	**NC	**NC	**NC	**NC	**NC	**NC
Average Annual Order Price:	**NC	**NC	**NC	**NC	**NC	**NC

*NOTE: July 2017 – June 2018 data is unaudited. With each successive period, new data will be added until six 6-month periods are displayed.

**NC = None Claimed.

GEOGRAPHICAL BREAKOUT OF QUALIFIED CIRCULATION FOR ISSUE OF MAY 2018

State	Total Qualified	Percent	State	Total Qualified	Percent
Maine	72		Kentucky	220	
New Hampshire	92		Tennessee	333	
Vermont	34		Alabama	236	
Massachusetts	438		Mississippi	70	
Rhode Island	67		EAST SO. CENTRAL	859	4.8
Connecticut	274		Arkansas	105	
NEW ENGLAND	977	5.4	Louisiana	210	
New York	987		Oklahoma	160	
New Jersey	434		Texas	1,015	
Pennsylvania	573		WEST SO. CENTRAL	1,490	8.3
MIDDLE ATLANTIC	1,994	11.1	Montana	107	
Ohio	590		Idaho	111	
Indiana	404		Wyoming	48	
Illinois	846		Colorado	558	
Michigan	529		New Mexico	90	
Wisconsin	294		Arizona	356	
EAST NO. CENTRAL	2,663	14.8	Utah	215	
Minnesota	362		Nevada	159	
Iowa	224		MOUNTAIN	1,644	9.1
Missouri	344		Alaska	76	
North Dakota	64		Washington	723	
South Dakota	70		Oregon	309	
Nebraska	131		California	2,358	
Kansas	170		Hawaii	125	
WEST NO. CENTRAL	1,365	7.6	PACIFIC	3,591	20.0
Delaware	58		UNITED STATES	17,955	99.8
Maryland	374		U.S. Territories	7	
Washington, DC	56		Canada	37	
Virginia	481		Mexico	-	
West Virginia	51		Other International	-	
North Carolina	469		APO/FPO	1	
South Carolina	216				
Georgia	496				
Florida	1,171				
SOUTH ATLANTIC	3,372	18.7			
			TOTAL QUALIFIED CIRCULATION	18,000	100.0

GEOGRAPHICAL BREAKOUT OF QUALIFIED CIRCULATION

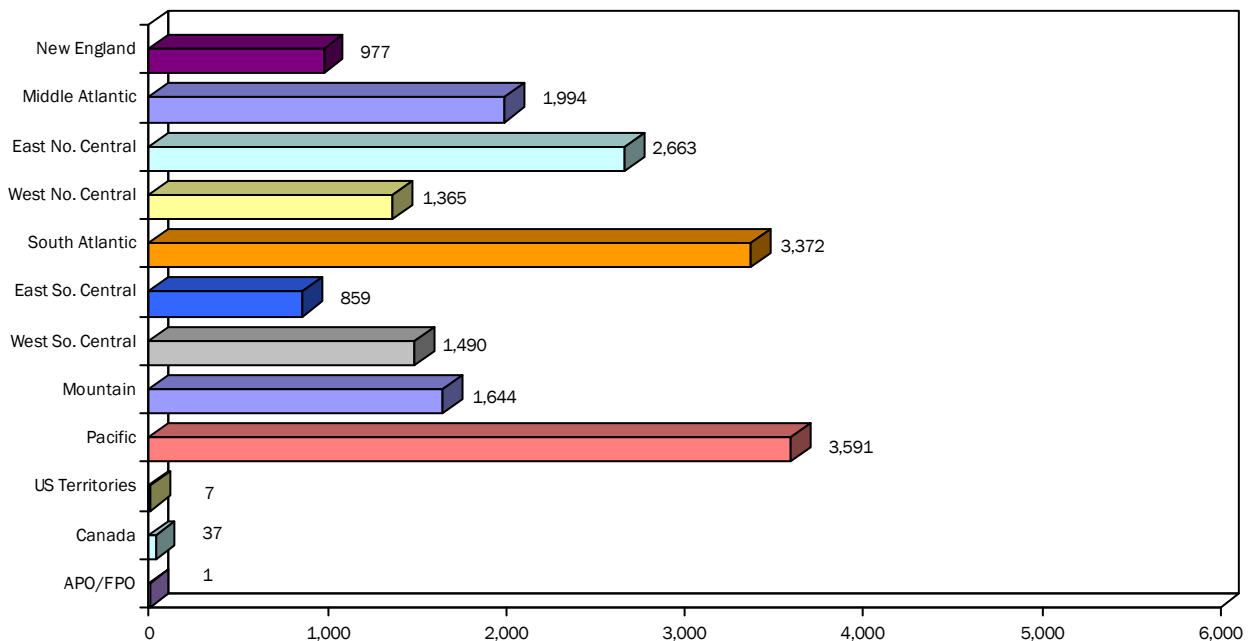

ADDITIONAL DATA

PARAGRAPH 2- LATE MAILING OF ISSUES:

18,282 copies or 100% of the total copies distributed for the May 2018 issue were mailed on June 5, 2018.

PARAGRAPH 3b:

Association rosters and directories include 2 sources of circulation for a quantity of 1,445 copies or 8.0%, to 3,508 or 19.5% including Amateur Athletic Union 2016 and 2017 NASC Members List.

Other sources include 3 sources of circulation for quantities of 579 copies or 3.2% to 11,135 copies or 61.8%, including InfoUSA.

PUBLISHER'S AFFIDAVIT

We hereby make oath and say that all data set forth in this statement are true.

Ashley Strickland, Circulation Manager

Ashleigh Osborne, Associate Publisher

(At least one of the above signatures must be that of an officer of the publishing company or its authorized representative.)

IMPORTANT NOTE:

This unaudited brand report has been checked against the previous audit report. It will be included in the annual audit made by BPA Worldwide.

Date signed	August 8, 2018
State	Alabama
County	Baldwin
Received by BPA Worldwide	August 8, 2018
Type	BJ
ID Number	S380B0J8

About BPA Worldwide:

A not-for-profit organization since 1931, BPA Worldwide is governed by a tripartite board comprised of media owners, advertising agencies and advertisers. Headquartered in Shelton, Connecticut, USA, BPA has the largest membership of any media-auditing organization in the world, spanning more than 30 countries. Globally, BPA audits media properties including consumer magazines, newspapers, web sites, events, email newsletters, databases, wireless, social media and other advertiser-supported media—as well as advertiser and agency members. Visit www.bpaww.com for the latest audit reports, membership information and publishing and advertising industry news.