

COLUMBIA COUNTY BOARD OF COUNTY COMMISSIONERS

**POST OFFICE BOX 1529
LAKE CITY, FLORIDA 32056-1529**

CONSENT AGENDA

September 20, 2018

5:30 P.M.

-
- (1) BCC Administration - BA 18-71 - Install Fort White Substation Push Plate Door Opener - \$2,304 (Pg. 1)**
 - (2) BCC Administration - BA 18-73 - CDBG Grant - Plantation Park - Survey Work for CDBG Neighborhood Revitalization Project - \$7,000 (Pg. 3)**
 - (3) BCC Administration - FY 2018-2019 Contract Between Columbia County and Department of Health - \$153,784 (Pg. 5)**
 - (4) BCC Administration - Palms Medical Group - Renewal Contract for Services - \$48,500 (Pg. 25)**
 - (5) BCC Administration - Release of Lien - Suwannee River Economic Council (S.H.I.P.) - Barbara B. Hatcher - \$12,000 (Pg. 29)**
 - (6) BCC Administration - Minutes - Board of County Commissioners - Regular Meeting - September 6, 2018 (Pg. 32)**
 - (7) BCC Administration - Summers Elementary - Evacuation Site (Pg. 43)**
 - (8) Clerk to Board Finance - Payment of Bills and Vouchers - \$1,796,031 (Pg. 45)**
 - (9) Economic Development - Resolution No. 2018-42 - Amend and Restate Resolution No. 2018R-28 (Pg. 49)**
 - (10) Library - Annual Food for Fines Library Project - November 13-19, 2018 (Pg. 53)**
 - (11) Library - Closing for Veterans Day, November 11, 2018 in Addition to November 12, 2018 (Pg. 55)**
 - (12) Library - LSTA Innovation Grant Application - \$3,882 (Pg. 57)**
 - (13) Landscape and Parks - BA 18-70 - Contribution from Lake City Columbia County Youth Baseball Association - \$4,000 (Pg. 67)**

- (14) Public Works - Entering Private Property - 8355 South US Highway 441 - Arky Rogers, Property Owner - Dangerous Tree Removal on County Right-of-Way (Pg. 68)**
- (15) Public Works - Utility Permit - AT&T - NW Guerdon Street (Pg. 72)**
- (16) Public Works - Utility Permit - City of Lake City - NE Bascom Norris Drive (Pg. 79)**
- (17) Public Works - Utility Permit - Clay Electric - Herlong Road (Pg. 84)**
- (18) Public Works - Utility Permit - Comcast - SW Woodgate Terrace (Pg. 91)**
- (19) Public Works - Utility Permit - Florida Power & Light - SW Hartridge Drive (Pg. 104)**
- (20) Recreation - BA 18-72 - Network Switch Replacement - \$3,300 (Pg. 113)**
- (21) Solid Waste - FDACS/Columbia County - FY 2018-2019 Mosquito Control Contract - \$33,403 (Pg. 115)**



COLUMBIA COUNTY BOARD OF COUNTY COMMISSIONERS AGENDA ITEM REQUEST FORM

The Board of County Commissioners meets the 1st and 3rd Thursday of each month at 5:30 p.m. in the Columbia County School Board Administrative Complex Auditorium, 372 West Duval Street, Lake City, Florida 32055. All agenda items are due in the Board's office one week prior to the meeting date.

Today's Date: September 13, 2018 Meeting Date: September 20, 2018

Name: Ben Scott Department: BCC Administration

Division Manager's Signature: *Ben Scott*

1. Nature and purpose of agenda item:

BA 18-71--Install Fort White Substation Push Plate Door Opener - \$2,304

Attach any correspondence information, documents and forms for action i.e., contract agreements, quotes, memorandums, etc.

2. Fiscal impact on current budget.

Is this a budgeted item? N/A
 Yes Account No. _____
 No Please list the proposed budget amendment to fund this request

Budget Amendment Number: BA 18-71 Fund: 001-GENERAL FUND

FROM:	TO:	AMOUNT:
001-8400-584.90-99 RESERVES / CONTINGENCY/RESERVE	001-1000-511.30-49 OPERATING EXPENDITURES / OTHER CHARGES	\$2,304.00

For Use of County Manager Only:

Consent Item Discussion Item



J Newton Enterprises, Inc.
 755 S. Little John Avenue
 Inverness, FL 34450
 Ph: (877) 317-5854 Fax: (352) 726-6124
 Prepared by: Ben Gardner (904) 738-1576
 Email: ben@jnewtonenterprises.com

Quote

Date	Quote #
8/30/2018	65002

Customer
2160 NE Washington Street Lake City FL 32056

Contact	Phone
Tom Wilcutts	(386) 867-0954
Email	
twilcutts@columbiacountyfla.com	

Project
Ft White Tax Collector / Sherrifs Sub-Station

Location
NW 1st Ave FT White FL

Description

To provide and install material listed below, we are pleased to propose the following price:

TO INCLUDE:

- 1 39" RHR Bronze Horton 7100
- 1 Push Plate Package 900mhz

WARRANTY: One year on materials

Price includes travel, labor, materials, and shipping

25% Deposit due upon ordering, balance due upon completion of job

Exclusions: Painting, patching, plastering, flooring conditions, permitting & permitting fees, engineered drawings, after-hours labor, existing doors, frames & hardware, 110 volt service, low voltage wiring, fire alarm and wiring, card readers, and any and all work not specifically mentioned in this proposal

Please allow approximately four to five weeks after receipt of signed quote, PO, or contract for work to begin.

Please sign and email back to ben@jnewtonenterprises.com

NOTE: If job is paid by credit card, 3% will be added to the quoted price

NOTE: Any special endorsements and/or insurance requirements that are needed above and beyond what J Newton Enterprises, Inc. currently has in place are not covered in the quote price. Cost for additional insurance premiums that are needed will be the sole responsibility of the customer and will be added to the below price.

J Newton Enterprises is a State Certified Minority Woman-Owned Business.
This estimate is subject to review or void if not accepted within 30 days.

Total	\$ 2,304.00
--------------	--------------------

Accepted By: _____

Signature: _____



COLUMBIA COUNTY BOARD OF COUNTY COMMISSIONERS
AGENDA ITEM REQUEST FORM

The Board of County Commissioners meets the 1st and 3rd Thursday of each month at 5:30 p.m. in the Columbia County School Board Administrative Complex Auditorium, 372 West Duval Street, Lake City, Florida 32055. All agenda items are due in the Board's office one week prior to the meeting date.

Today's Date: September 13, 2018 Meeting Date: September 20, 2018

Name: David Kraus Department: CDBG Grant - Plantation Park

Division Manager's Signature: [Handwritten Signature]

1. Nature and purpose of agenda item:

To Request Approval of Budget Amendment to move \$7,000 into the CDBG Plantation Park Project for survey work.

Attach any correspondence information, documents and forms for action i.e., contract agreements, quotes, memorandums, etc.

2. Fiscal impact on current budget.

Is this a budgeted item? [] N/A [] Yes Account No. [X] No Please list the proposed budget amendment to fund this request

Budget Amendment Number: BA 18-73 Fund: 405-UTILITIES FUND

Table with 3 columns: FROM, TO, AMOUNT. Rows include budget codes and descriptions like OPERATING EXPENDITURES / TRAINING, INTERFUND TRANSFERS OUT / TO ROAD IMPROVEMENT FUND, etc.

For Use of County Manager Only:

[X] Consent Item [] Discussion Item



BOARD OF COUNTY COMMISSIONERS • COLUMBIA COUNTY

MEMORANDUM

DATE: September 12, 2018

TO: Columbia County Board of County Commissioners

FR: David Kraus, Assistant County Manager

A handwritten signature in blue ink, appearing to read "DK", is placed to the right of the "FR:" line.

RE: CDBG Plantation Park – Budget Amendment

The Department of Economic Opportunity recently approved the environmental review for the CDBG Neighborhood Revitalization project known as Plantation Park. As part of the project, the County is providing engineering services as part of the \$50,000 leverage match to the \$750,000 CDBG grant.

Now that the environmental review is accepted and DEO has released the funds for the project to proceed, we can complete the final design and proceed with the RFP process. A survey of the project is necessary for the final design and bid specs. DEO has determined that the survey cost should be part of the \$50,000 match and not charged to the grant. Because we anticipated using in-kind engineering as the match, no funds for the match were appropriated in the grant account. Staff has prepared a Budget Amendment for \$7,000 to place funds in the grant accounts for the cost of the survey.

We are requesting the Columbia County Board of County Commissioner approve a Budget Amendment transferring \$7,000 into project G322 – CDBG Plantation Park as matching funds (\$3,500 in CDBG Utilities and \$3,500 in CDBG Roads).



COLUMBIA COUNTY BOARD OF COUNTY COMMISSIONERS AGENDA ITEM REQUEST FORM

The Board of County Commissioners meets the 1st and 3rd Thursday of each month at 5:30 p.m. in the Columbia County School Board Administrative Complex Auditorium, 372 West Duval Street, Lake City, Florida 32055. All agenda items are due in the Board's office one week prior to the meeting date.

Today's Date: September 6, 2018 Meeting Date: September 20, 2018

Name: Penny Stanley Department: BCC Administration

Division Manager's Signature: *Ben Scott*

1. Nature and purpose of agenda item:

2018-2019 Contract Between Columbia County and Department of Health

Attach any correspondence information, documents and forms for action i.e., contract agreements, quotes, memorandums, etc.

2. Fiscal impact on current budget.

Is this a budgeted item? N/A
 Yes Account No. _____
 No Please list the proposed budget amendment to fund this request

Budget Amendment Number: _____ Fund: _____

FROM: _____ TO: _____ AMOUNT: _____

For Use of County Manager Only:

Consent Item Discussion Item

**CONTRACT BETWEEN
COLUMBIA COUNTY BOARD OF COUNTY COMMISSIONERS
AND
STATE OF FLORIDA DEPARTMENT OF HEALTH
FOR OPERATION OF THE
COLUMBIA COUNTY HEALTH DEPARTMENT
CONTRACT YEAR 2018-2019**

This contract is made and entered into between the State of Florida, Department of Health ("State") and the Columbia County Board of County Commissioners ("County"), through their undersigned authorities, effective October 1, 2018.

RECITALS

A. Pursuant to Chapter 154, Florida Statutes, the intent of the legislature is to "promote, protect, maintain, and improve the health and safety of all citizens and visitors of this state through a system of coordinated county health department services."

B. County Health Departments were created throughout Florida to satisfy this legislative intent through "promotion of the public's health, the control and eradication of preventable diseases, and the provision of primary health care for special populations."

C. Columbia County Health Department ("CHD") is one of the created County Health Departments.

D. It is necessary for the parties hereto to enter into this contract in order to ensure coordination between the State and the County in the operation of the CHD.

NOW THEREFORE, in consideration of the mutual promises set forth herein, the sufficiency of which are hereby acknowledged, the parties hereto agree as follows:

1. RECITALS. The parties mutually agree that the foregoing recitals are true and correct and incorporated herein by reference.

2. TERM. The parties mutually agree that this contract shall be effective from October 1, 2018, through September 30, 2019, or until a written contract replacing this contract is entered into between the parties, whichever is later, unless this contract is otherwise terminated pursuant to the termination provisions set forth in paragraph 8. below.

3. SERVICES MAINTAINED BY THE CHD. The parties mutually agree that the CHD shall provide those services as set forth on Part III of Attachment II hereof, in order to maintain the following three levels of service pursuant to section 154.01(2), Florida Statutes, as defined below:

a. "Environmental health services" are those services which are organized and operated to protect the health of the general public by monitoring and regulating activities in the environment which may contribute to the occurrence or transmission of disease.

Environmental health services shall be supported by available federal, state and local funds and shall include those services mandated on a state or federal level. Examples of environmental health services include, but are not limited to, food hygiene, safe drinking water supply, sewage and solid waste disposal, swimming pools, group care facilities, migrant labor camps, toxic material control, radiological health, and occupational health.

b. "Communicable disease control services" are those services which protect the health of the general public through the detection, control, and eradication of diseases which are transmitted primarily by human beings. Communicable disease services shall be supported by available federal, state, and local funds and shall include those services mandated on a state or federal level. Such services include, but are not limited to, epidemiology, sexually transmissible disease detection and control, HIV/AIDS, immunization, tuberculosis control and maintenance of vital statistics.

c. "Primary care services" are acute care and preventive services that are made available to well and sick persons who are unable to obtain such services due to lack of income or other barriers beyond their control. These services are provided to benefit individuals, improve the collective health of the public, and prevent and control the spread of disease. Primary health care services are provided at home, in group settings, or in clinics. These services shall be supported by available federal, state, and local funds and shall include services mandated on a state or federal level. Examples of primary health care services include, but are not limited to: first contact acute care services; chronic disease detection and treatment; maternal and child health services; family planning; nutrition; school health; supplemental food assistance for women, infants, and children; home health; and dental services.

4. FUNDING. The parties further agree that funding for the CHD will be handled as follows:

a. The funding to be provided by the parties and any other sources is set forth in Part II of Attachment II hereof. This funding will be used as shown in Part I of Attachment II.

i. The State's appropriated responsibility (*direct contribution excluding any state fees, Medicaid contributions or any other funds not listed on the Schedule C*) as provided in Attachment II, Part II is an amount not to exceed \$ 1,195,775 _____ (*State General Revenue, State Funds, Other State Funds and Federal Funds listed on the Schedule C*). The State's obligation to pay under this contract is contingent upon an annual appropriation by the Legislature.

ii. The County's appropriated responsibility (*direct contribution excluding any fees, other cash or local contributions*) as provided in Attachment II, Part II is an amount not to exceed \$ 153,784 _____ (*amount listed under the "Board of County Commissioners Annual Appropriations section of the revenue attachment*).

b. Overall expenditures will not exceed available funding or budget authority, whichever is less, (either current year or from surplus trust funds) in any service category. Unless requested otherwise, any surplus at the end of the term of this contract in the County Health

Department Trust Fund that is attributed to the CHD shall be carried forward to the next contract period.

c. Either party may establish service fees as allowed by law to fund activities of the CHD. Where applicable, such fees shall be automatically adjusted to at least the Medicaid fee schedule.

d. Either party may increase or decrease funding of this contract during the term hereof by notifying the other party in writing of the amount and purpose for the change in funding. If the State initiates the increase/decrease, the CHD will revise the Attachment II and send a copy of the revised pages to the County and the Department of Health, Office of Budget and Revenue Management. If the County initiates the increase/decrease, the County shall notify the CHD. The CHD will then revise the Attachment II and send a copy of the revised pages to the Department of Health, Office of Budget and Revenue Management.

e. The name and address of the official payee to whom payments shall be made is:

County Health Department Trust Fund
Columbia County
217 NE Franklin Street
Lake City, FL 32055

5. CHD DIRECTOR/ADMINISTRATOR. Both parties agree the director/administrator of the CHD shall be a State employee or under contract with the State and will be under the day-to-day direction of the Deputy Secretary for County Health Systems. The director/administrator shall be selected by the State with the concurrence of the County. The director/administrator of the CHD shall ensure that non-categorical sources of funding are used to fulfill public health priorities in the community and the Long Range Program Plan.

6. ADMINISTRATIVE POLICIES AND PROCEDURES. The parties hereto agree that the following standards should apply in the operation of the CHD:

a. The CHD and its personnel shall follow all State policies and procedures, except to the extent permitted for the use of County purchasing procedures as set forth in subparagraph b., below. All CHD employees shall be State or State-contract personnel subject to State personnel rules and procedures. Employees will report time in the Health Management System compatible format by program component as specified by the State.

b. The CHD shall comply with all applicable provisions of federal and state laws and regulations relating to its operation with the exception that the use of County purchasing procedures shall be allowed when it will result in a better price or service and no statewide Department of Health purchasing contract has been implemented for those goods or services. In such cases, the CHD director/administrator must sign a justification therefore, and all County purchasing procedures must be followed in their entirety, and such compliance shall be documented. Such justification and compliance documentation shall be maintained by the CHD in accordance with the terms of this contract. State procedures must be followed for all leases on facilities not enumerated in Attachment IV.

c. The CHD shall maintain books, records and documents in accordance with the Generally Accepted Accounting Principles (GAAP), as promulgated by the Governmental Accounting Standards Board (GASB), and the requirements of federal or state law. These records shall be maintained as required by the Department of Health Policies and Procedures for Records Management and shall be open for inspection at any time by the parties and the public, except for those records that are not otherwise subject to disclosure as provided by law which are subject to the confidentiality provisions of paragraphs 6.i. and 6.k., below. Books, records and documents must be adequate to allow the CHD to comply with the following reporting requirements:

- i.* The revenue and expenditure requirements in the Florida Accounting Information Resource (FLAIR) System;
- ii.* The client registration and services reporting requirements of the minimum data set as specified in the most current version of the Client Information System/Health Management Component Pamphlet;
- iii.* Financial procedures specified in the Department of Health's Accounting Procedures Manuals, Accounting memoranda, and Comptroller's memoranda;
- iv.* The CHD is responsible for assuring that all contracts with service providers include provisions that all subcontracted services be reported to the CHD in a manner consistent with the client registration and service reporting requirements of the minimum data set as specified in the Client Information System/Health Management Component Pamphlet.

d. All funds for the CHD shall be deposited in the County Health Department Trust Fund maintained by the state treasurer. These funds shall be accounted for separately from funds deposited for other CHDs and shall be used only for public health purposes in Columbia County.

e. That any surplus/deficit funds, including fees or accrued interest, remaining in the County Health Department Trust Fund account at the end of the contract year shall be credited/debited to the State or County, as appropriate, based on the funds contributed by each and the expenditures incurred by each. Expenditures will be charged to the program accounts by State and County based on the ratio of planned expenditures in this contract and funding from all sources is credited to the program accounts by State and County. The equity share of any surplus/deficit funds accruing to the State and County is determined each month and at contract year-end. Surplus funds may be applied toward the funding requirements of each participating governmental entity in the following year. However, in each such case, all surplus funds, including fees and accrued interest, shall remain in the trust fund until accounted for in a manner which clearly illustrates the amount which has been credited to each participating governmental entity. The planned use of surplus funds shall be reflected in Attachment II, Part I of this contract, with special capital projects explained in Attachment V.

f. There shall be no transfer of funds between the three levels of services without a contract amendment unless the CHD director/administrator determines that an emergency exists wherein a time delay would endanger the public's health and the Deputy Secretary for County Health Systems has approved the transfer. The Deputy Secretary for County Health Systems shall forward written evidence of this approval to the CHD within 30 days after an emergency transfer.

g. The CHD may execute subcontracts for services necessary to enable the CHD to carry out the programs specified in this contract. Any such subcontract shall include all aforementioned audit and record keeping requirements.

h. At the request of either party, an audit may be conducted by an independent CPA on the financial records of the CHD and the results made available to the parties within 180 days after the close of the CHD fiscal year. This audit will follow requirements contained in OMB Circular A-133 and may be in conjunction with audits performed by County government. If audit exceptions are found, then the director/administrator of the CHD will prepare a corrective action plan and a copy of that plan and monthly status reports will be furnished to the contract managers for the parties.

i. The CHD shall not use or disclose any information concerning a recipient of services except as allowed by federal or state law or policy.

j. The CHD shall retain all client records, financial records, supporting documents, statistical records, and any other documents (including electronic storage media) pertinent to this contract for a period of five (5) years after termination of this contract. If an audit has been initiated and audit findings have not been resolved at the end of five (5) years, the records shall be retained until resolution of the audit findings.

k. The CHD shall maintain confidentiality of all data, files, and records that are confidential under the law or are otherwise exempted from disclosure as a public record under Florida law. The CHD shall implement procedures to ensure the protection and confidentiality of all such records and shall comply with sections 384.29, 381.004, 392.65 and 456.057, Florida Statutes, and all other state and federal laws regarding confidentiality. All confidentiality procedures implemented by the CHD shall be consistent with the Department of Health Information Security Policies, Protocols, and Procedures. The CHD shall further adhere to any amendments to the State's security requirements and shall comply with any applicable professional standards of practice with respect to client confidentiality.

l. The CHD shall abide by all State policies and procedures, which by this reference are incorporated herein as standards to be followed by the CHD, except as otherwise permitted for some purchases using County procedures pursuant to paragraph 6.b.

m. The CHD shall establish a system through which applicants for services and current clients may present grievances over denial, modification or termination of services. The CHD will advise applicants of the right to appeal a denial or exclusion from services, of failure to

take account of a client's choice of service, and of his/her right to a fair hearing to the final governing authority of the agency. Specific references to existing laws, rules or program manuals are included in Attachment I of this contract.

n. The CHD shall comply with the provisions contained in the Civil Rights Certificate, hereby incorporated into this contract as Attachment III.

o. The CHD shall submit quarterly reports to the County that shall include at least the following:

- i. The DE385L1 Contract Management Variance Report and the DE580L1 Analysis of Fund Equities Report;
- ii. A written explanation to the County of service variances reflected in the year end DE385L1 report if the variance exceeds or falls below 25 percent of the planned expenditure amount for the contract year. However, if the amount of the service specific variance between actual and planned expenditures does not exceed three percent of the total planned expenditures for the level of service in which the type of service is included, a variance explanation is not required. A copy of the written explanation shall be sent to the Department of Health, Office of Budget and Revenue Management.

p. The dates for the submission of quarterly reports to the County shall be as follows unless the generation and distribution of reports is delayed due to circumstances beyond the CHD's control:

- i. March 1, 2019 for the report period October 1, 2018 through December 31, 2018;
- ii. June 1, 2019 for the report period October 1, 2018 through March 31, 2019;
- iii. September 1, 2019 for the report period October 1, 2018 through June 30, 2019; and
- iv. December 1, 2019 for the report period October 1, 2018 through September 30, 2019.

7. FACILITIES AND EQUIPMENT. The parties mutually agree that:

a. CHD facilities shall be provided as specified in Attachment IV to this contract and the County shall own the facilities used by the CHD unless otherwise provided in Attachment IV.

b. The County shall ensure adequate fire and casualty insurance coverage for County-owned CHD offices and buildings and for all furnishings and equipment in CHD offices through either a self-insurance program or insurance purchased by the County.

c. All vehicles will be transferred to the ownership of the County and registered as County vehicles. The County shall ensure insurance coverage for these vehicles is available through either a self-insurance program or insurance purchased by the County. All vehicles will be used solely for CHD operations. Vehicles purchased through the County Health Department Trust Fund shall be sold at fair market value when they are no longer needed by the CHD and the proceeds returned to the County Health Department Trust Fund.

8. TERMINATION.

a. Termination at Will. This contract may be terminated by either party without cause upon no less than one-hundred eighty (180) calendar days notice in writing to the other party unless a lesser time is mutually agreed upon in writing by both parties. Said notice shall be delivered by certified mail, return receipt requested, or in person to the other party's contract manager with proof of delivery.

b. Termination Because of Lack of Funds. In the event funds to finance this contract become unavailable, either party may terminate this contract upon no less than twenty-four (24) hours notice. Said notice shall be delivered by certified mail, return receipt requested, or in person to the other party's contract manager with proof of delivery.

c. Termination for Breach. This contract may be terminated by one party, upon no less than thirty (30) days notice, because of the other party's failure to perform an obligation hereunder. Said notice shall be delivered by certified mail, return receipt requested, or in person to the other party's contract manager with proof of delivery. Waiver of breach of any provisions of this contract shall not be deemed to be a waiver of any other breach and shall not be construed to be a modification of the terms of this contract.

9. MISCELLANEOUS. The parties further agree:

a. Availability of Funds. If this contract, any renewal hereof, or any term, performance or payment hereunder, extends beyond the fiscal year beginning July 1, 2019, it is agreed that the performance and payment under this contract are contingent upon an annual appropriation by the Legislature, in accordance with section 287.0582, Florida Statutes.

b. Contract Managers. The name and address of the contract managers for the parties under this contract are as follows:

For the State:

Thomas P. Moffses, Jr
Name
Administrator
Title
217 NE Franklin Street

Lake City, FL 32055
Address

For the County:

Ben Scott
Name
County Manager
Title
PO Box 1529

Lake City, FL 32056-1529
Address

386-758-1037
Telephone

386-758-1005
Telephone

If different contract managers are designated after execution of this contract, the name, address and telephone number of the new representative shall be furnished in writing to the other parties and attached to originals of this contract.

c. Captions. The captions and headings contained in this contract are for the convenience of the parties only and do not in any way modify, amplify, or give additional notice of the provisions hereof.

In WITNESS THEREOF, the parties hereto have caused this eight-page contract, with its attachments as referenced, including Attachment I (two pages), Attachment II (six pages), Attachment III (one page), Attachment IV (one page), and Attachment V (one page), to be executed by their undersigned officials as duly authorized effective the 1st day of October, 2018.

**BOARD OF COUNTY COMMISSIONERS
FOR COLUMBIA COUNTY**

**STATE OF FLORIDA
DEPARTMENT OF HEALTH**

SIGNED BY: _____

NAME: Timothy Murphy

TITLE: Chairman

DATE: _____

SIGNED BY: _____

NAME: Celeste Philip, MD, MPH

TITLE: Surgeon General and Secretary

DATE: _____

ATTESTED TO:

SIGNED BY: _____

NAME: Ben Scott

TITLE: County Manager

DATE: _____

SIGNED BY: 

NAME: Thomas P. Moffses, Jr.

TITLE: CHD Administrator

DATE: 9/4/18

ATTACHMENT I
COLUMBIA COUNTY HEALTH DEPARTMENT
PROGRAM SPECIFIC REPORTING REQUIREMENTS AND PROGRAMS REQUIRING
COMPLIANCE WITH THE PROVISIONS OF SPECIFIC MANUALS

Some health services must comply with specific program and reporting requirements in addition to the Personal Health Coding Pamphlet (DHP 50-20), Environmental Health Coding Pamphlet (DHP 50-21) and FLAIR requirements because of federal or state law, regulation or rule. If a county health department is funded to provide one of these services, it must comply with the special reporting requirements for that service. The services and the reporting requirements are listed below:

<u>Service</u>	<u>Requirement</u>
1. Sexually Transmitted Disease Program	Requirements as specified in F.A.C. 64D-3, F.S. 381 and F.S. 384.
2. Dental Health	Periodic financial and programmatic reports as specified by the program office.
3. Special Supplemental Nutrition Program for Women, Infants and Children (including the WIC Breastfeeding Peer Counseling Program)	Service documentation and monthly financial reports as specified in DHM 150-24* and all federal, state and county requirements detailed in program manuals and published procedures.
4. Healthy Start/ Improved Pregnancy Outcome	Requirements as specified in the 2007 Healthy Start Standards and Guidelines and as specified by the Healthy Start Coalitions in contract with each county health department.
5. Family Planning	Requirements as specified in Public Law 91-572, 42 U.S.C. 300, et seq., 42 CFR part 59, subpart A, 45 CFR parts 74 & 92, 2 CFR 215 (OMB Circular A-110) OMB Circular A-102, F.S. 381.0051, F.A.C. 64F-7, F.A.C. 64F-16, and F.A.C. 64F-19. Requirements and Guidance as specified in the Program Requirements for Title X Funded Family Planning Projects (Title X Requirements)(2014) and the Providing Quality Family Planning Services (QFP): Recommendations of CDC and the U.S. Office of Population Affairs published on the Office of Population Affairs website. Programmatic annual reports as specified by the program office as specified in the annual programmatic Scope of Work for Family Planning and Maternal Child Health Services, including the Family Planning Annual Report (FPAR), and other minimum guidelines as specified by the Policy Web Technical Assistance Guidelines.
6. Immunization	Periodic reports as specified by the department pertaining to immunization levels in kindergarten and/or seventh grade pursuant to instructions contained in the Immunization Guidelines-Florida Schools, Childcare Facilities and Family Daycare Homes (DH Form 150-615) and Rule 64D-3.046, F.A.C. In addition, periodic reports as specified by the department pertaining to the surveillance/investigation of reportable vaccine-preventable diseases, adverse events, vaccine accountability, and assessment of immunization

ATTACHMENT I (Continued)

- levels as documented in Florida SHOTS and supported by CHD Guidebook policies and technical assistance guidance.
7. Environmental Health
Requirements as specified in Environmental Health Programs Manual 150-4* and DHP 50-21*
 8. HIV/AIDS Program
Requirements as specified in F.S. 384.25 and F.A.C. 64D-3.030 and 64D-3.031. Case reporting should be on Adult HIV/AIDS Confidential Case Report CDC Form DH2139 and Pediatric HIV/AIDS Confidential Case Report CDC Form DH2140.

Requirements as specified in F.A.C. 64D-2 and 64D-3, F.S. 381 and F.S. 384. Socio-demographic and risk data on persons tested for HIV in CHD clinics should be reported on Lab Request DH Form 1628 in accordance with the Forms Instruction Guide. Requirements for the HIV/AIDS Patient Care programs are found in the Patient Care Contract Administrative Guidelines.
 9. School Health Services
Requirements as specified in the Florida School Health Administrative Guidelines (May 2012). Requirements as specified in F.S. 381.0056, F.S. 381.0057, F.S. 402.3026 and F.A.C. 64F-6.
 10. Tuberculosis
Tuberculosis Program Requirements as specified in F.A.C. 64D-3 and F.S. 392.
 11. General Communicable Disease Control
Carry out surveillance for reportable communicable and other acute diseases, detect outbreaks, respond to individual cases of reportable diseases, investigate outbreaks, and carry out communication and quality assurance functions, as specified in F.A.C. 64D-3, F.S. 381, F.S. 384 and the CHD Epidemiology Guide to Surveillance and Investigations.
 12. Refugee Health Program
Programmatic and financial requirements as specified by the program office.

*or the subsequent replacement if adopted during the contract period.

ATTACHMENT II
COLUMBIA COUNTY HEALTH DEPARTMENT
PART I. PLANNED USE OF COUNTY HEALTH DEPARTMENT TRUST FUND BALANCES

	Estimated State Share of CHD Trust Fund Balance	Estimated County Share of CHD Trust Fund Balance	Total
1. CHD Trust Fund Ending Balance 09/30/18	122717	216054	338771
2. Drawdown for Contract Year October 1, 2018 to September 30, 2019	-122717	-37752	-160469
3. Special Capital Project use for Contract Year October 1, 2018 to September 30, 2019	0	0	0
4. Balance Reserved for Contingency Fund October 1, 2018 to September 30, 2019	0	178302	178302

Special Capital Projects are new construction or renovation projects and new furniture or equipment associated with these projects, and mobile health vans.

ATTACHMENT II

COLUMBIA COUNTY HEALTH DEPARTMENT

Part II, Sources of Contributions to County Health Department

October 1, 2018 to September 30, 2019

	State CHD Trust Fund (cash)	County CHD Trust Fund	Total CHD Trust Fund (cash)	Other Contribution	Total
1. GENERAL REVENUE - STATE					
015040 AIDS PREVENTION & SURVEILLANCE - GENERAL REVENUE	36,053	0	36,053	0	36,053
015040 CHD - TB COMMUNITY PROGRAM	12,121	0	12,121	0	12,121
015040 DENTAL SPECIAL INITIATIVE PROJECTS	5,977	0	5,977	0	5,977
015040 FAMILY PLANNING GENERAL REVENUE	23,758	0	23,758	0	23,758
015040 FLORIDA SPRINGS AND AQUIFER PROTECTION ACT	72,939	0	72,939	0	72,939
015040 PRIMARY CARE PROGRAM	118,600	0	118,600	0	118,600
015040 SCHOOL HEALTH SERVICES - GENERAL REVENUE	98,711	0	98,711	0	98,711
015050 CHD GENERAL REVENUE NON-CATEGORICAL	502,877	0	502,877	0	502,877
GENERAL REVENUE TOTAL	871,036	0	871,036	0	871,036
2. NON GENERAL REVENUE - STATE					
015010 CESSATION TREATMENT AND COUNSELING	23,536	0	23,536	0	23,536
NON GENERAL REVENUE TOTAL	23,536	0	23,536	0	23,536
3. FEDERAL FUNDS - STATE					
007000 COMPREHENSIVE COMMUNITY CARDIO - PHBG	38,389	0	38,389	0	38,389
007000 CMS-MCH PURCHASED CLIENT SERVICES	21,833	0	21,833	0	21,833
007000 DIABETES PREVENTION PUBLIC HEALTH FUNDING	2,527	0	2,527	0	2,527
007000 FAMILY PLANNING TITLE X - GRANT	44,212	0	44,212	0	44,212
007000 HEART DISEASE PREVENTION PUBLIC HEALTH FUNDING	434	0	434	0	434
007000 HPP MEDICAL LOGISTICS (MED MATERIAL MGMT & DIST)	105	0	105	0	105
007000 IMMUNIZATION ACTION PLAN	9,290	0	9,290	0	9,290
007000 MCH SPECIAL PROJCT DENTAL	13,147	0	13,147	0	13,147
007000 MCH SPECIAL PROJECTS DENTAL	2,842	0	2,842	0	2,842
007000 BASE COMMUNITY PREPAREDNESS CAPABILITY	163,784	0	163,784	0	163,784
015075 INSPECTIONS OF SUMMER FEEDING PROGRAM - DOE	4,211	0	4,211	0	4,211
015075 SUPPLEMENTAL SCHOOL HEALTH	18,123	0	18,123	0	18,123
015075 REFUGEE HEALTH SCREENING REIMBURSEMENT ADMIN	120	0	120	0	120
015075 REFUGEE HEALTH SCREENING REIMBURSEMENT SERVICES	1,000	0	1,000	0	1,000
018005 AIDS DRUG ASSISTANCE PROGRAM ADMIN HQ	12,246	0	12,246	0	12,246
FEDERAL FUNDS TOTAL	332,263	0	332,263	0	332,263
4. FEES ASSESSED BY STATE OR FEDERAL RULES - STATE					
001020 CHD STATEWIDE ENVIRONMENTAL FEES	53,450	0	53,450	0	53,450
001092 CHD STATEWIDE ENVIRONMENTAL FEES	178,069	0	178,069	0	178,069
001206 ON SITE SEWAGE DISPOSAL PERMIT FEES	19,215	0	19,215	0	19,215
001206 SANITATION CERTIFICATES (FOOD INSPECTION)	2,293	0	2,293	0	2,293
001206 SEPTIC TANK RESEARCH SURCHARGE	2,244	0	2,244	0	2,244
001206 SEPTIC TANK VARIANCE FEES 50%	355	0	355	0	355
001206 PUBLIC SWIMMING POOL PERMIT FEES-10% HQ TRANSFER	263	0	263	0	263
001206 DRINKING WATER PROGRAM OPERATIONS	1,662	0	1,662	0	1,662
001206 TANNING FACILITIES	197	0	197	0	197
001206 ONSITE SEWAGE TRAINING CENTER	2,125	0	2,125	0	2,125

ATTACHMENT II

COLUMBIA COUNTY HEALTH DEPARTMENT

Part II, Sources of Contributions to County Health Department

October 1, 2018 to September 30, 2019

	State CHD Trust Fund (cash)	County CHD Trust Fund	Total CHD Trust Fund (cash)	Other Contribution	Total
001206 MOBILE HOME & RV PARK FEES	1,541	0	1,541	0	1,541
FEES ASSESSED BY STATE OR FEDERAL RULES TOTAL	261,414	0	261,414	0	261,414
5. OTHER CASH CONTRIBUTIONS - STATE:					
	0	0	0	0	0
090001 DRAW DOWN FROM PUBLIC HEALTH UNIT	122,717	0	122,717	0	122,717
OTHER CASH CONTRIBUTION TOTAL	122,717	0	122,717	0	122,717
6. MEDICAID - STATE/COUNTY:					
001057 CHD CLINIC FEES	0	29,640	29,640	0	29,640
001147 CHD CLINIC FEES	0	5,880	5,880	0	5,880
001148 CHD CLINIC FEES	0	316,173	316,173	0	316,173
001148 GENERAL CLINIC RABIES SERVICES & DRUG PURCHASES	0	1,000	1,000	0	1,000
MEDICAID TOTAL	0	352,693	352,693	0	352,693
7. ALLOCABLE REVENUE - STATE:					
001004 CHD STATEWIDE ENVIRONMENTAL FEES	5	0	5	0	5
001004 VITAL STATISTICS CERTIFIED RECORDS	13	0	13	0	13
031005 GENERAL CLINIC RABIES SERVICES & DRUG PURCHASES	5,250	0	5,250	0	5,250
038000 CHD STATEWIDE ENVIRONMENTAL FEES	20	0	20	0	20
ALLOCABLE REVENUE TOTAL	5,288	0	5,288	0	5,288
8. OTHER STATE CONTRIBUTIONS NOT IN CHD TRUST FUND - STATE					
ADAP	0	0	0	102,816	102,816
PHARMACY DRUG PROGRAM	0	0	0	8,394	8,394
WIC PROGRAM	0	0	0	1,615,764	1,615,764
BUREAU OF PUBLIC HEALTH LABORATORIES	0	0	0	8,417	8,417
IMMUNIZATIONS	0	0	0	46,366	46,366
OTHER STATE CONTRIBUTIONS TOTAL	0	0	0	1,781,757	1,781,757
9. DIRECT LOCAL CONTRIBUTIONS - BCC/TAX DISTRICT					
008005 CHD LOCAL REVENUE & EXPENDITURES	0	153,784	153,784	0	153,784
DIRECT COUNTY CONTRIBUTIONS TOTAL	0	153,784	153,784	0	153,784
10. FEES AUTHORIZED BY COUNTY ORDINANCE OR RESOLUTION - COUNTY					
001077 CHD CLINIC FEES	0	13,077	13,077	0	13,077
001094 CHD LOCAL ENVIRONMENTAL FEES	0	74,765	74,765	0	74,765
001110 VITAL STATISTICS CERTIFIED RECORDS	0	85,000	85,000	0	85,000
FEES AUTHORIZED BY COUNTY TOTAL	0	172,842	172,842	0	172,842
11. OTHER CASH AND LOCAL CONTRIBUTIONS - COUNTY					
001029 CHD CLINIC FEES	0	10,390	10,390	0	10,390
001029 GENERAL CLINIC RABIES SERVICES & DRUG PURCHASES	0	1,000	1,000	0	1,000
001090 CHD CLINIC FEES	0	10,060	10,060	0	10,060
005000 CHD LOCAL REVENUE & EXPENDITURES	0	1,650	1,650	0	1,650

ATTACHMENT II

COLUMBIA COUNTY HEALTH DEPARTMENT

Part II, Sources of Contributions to County Health Department

October 1, 2018 to September 30, 2019

	State CHD Trust Fund (cash)	County CHD Trust Fund	Total CHD Trust Fund (cash)	Other Contribution	Total
011000 RYAN WHITE CONTRACTED GRANT PROGRAM	0	42,700	42,700	0	42,700
011001 CHD HEALTHY START COALITION CONTRACT	0	339,969	339,969	0	339,969
090002 DRAW DOWN FROM PUBLIC HEALTH UNIT	0	37,752	37,752	0	37,752
OTHER CASH AND LOCAL CONTRIBUTIONS TOTAL	0	443,521	443,521	0	443,521
12. ALLOCABLE REVENUE - COUNTY					
001004 CHD STATEWIDE ENVIRONMENTAL FEES	0	5	5	0	5
001004 VITAL STATISTICS CERTIFIED RECORDS	0	13	13	0	13
031005 GENERAL CLINIC RABIES SERVICES & DRUG PURCHASES	0	5,250	5,250	0	5,250
038000 CHD STATEWIDE ENVIRONMENTAL FEES	0	20	20	0	20
COUNTY ALLOCABLE REVENUE TOTAL	0	5,288	5,288	0	5,288
13. BUILDINGS - COUNTY					
ANNUAL RENTAL EQUIVALENT VALUE	0	0	0	164,700	164,700
OTHER (Specify)	0	0	0	0	0
UTILITIES	0	0	0	7,200	7,200
BUILDING MAINTENANCE	0	0	0	6,000	6,000
GROUNDS MAINTENANCE	0	0	0	0	0
INSURANCE	0	0	0	3,000	3,000
OTHER (Specify)	0	0	0	0	0
OTHER (Specify)	0	0	0	0	0
BUILDINGS TOTAL	0	0	0	180,900	180,900
14. OTHER COUNTY CONTRIBUTIONS NOT IN CHD TRUST FUND - COUNTY					
EQUIPMENT / VEHICLE PURCHASES	0	0	0	0	0
VEHICLE INSURANCE	0	0	0	3,000	3,000
VEHICLE MAINTENANCE	0	0	0	0	0
OTHER COUNTY CONTRIBUTION (SPECIFY)	0	0	0	0	0
OTHER COUNTY CONTRIBUTION (SPECIFY)	0	0	0	0	0
OTHER COUNTY CONTRIBUTIONS TOTAL	0	0	0	3,000	3,000
GRAND TOTAL CHD PROGRAM	1,616,254	1,128,128	2,744,382	1,965,657	4,710,039

ATTACHMENT II

COLUMBIA COUNTY HEALTH DEPARTMENT

Part III, Planned Staffing, Clients, Services and Expenditures By Program Service Area Within Each Level of Service

October 1, 2018 to September 30, 2019

	FTE's (0.00)	Clients Units	Services/ Visits	Quarterly Expenditure Plan				State	County	Grand Total
				1st	2nd (Whole dollars only)	3rd	4th			
A. COMMUNICABLE DISEASE CONTROL:										
IMMUNIZATION (101)	0.92	625	712	19,682	22,957	19,682	22,957	51,177	34,101	85,278
SEXUALLY TRANS. DIS. (102)	1.72	753	1,218	31,592	36,848	31,592	36,848	102,136	34,744	136,880
HIV/AIDS PREVENTION (03A1)	0.76	0	35	16,451	19,189	16,451	19,189	59,903	11,377	71,280
HIV/AIDS SURVEILLANCE (03A2)	0.00	0	0	0	0	0	0	0	0	0
HIV/AIDS PATIENT CARE (03A3)	1.23	161	362	21,523	25,104	21,523	25,105	11,227	82,028	93,255
ADAP (03A4)	0.32	7	9	4,739	5,527	4,739	5,527	15,752	4,780	20,532
TUBERCULOSIS (104)	0.37	404	813	6,326	7,378	6,326	7,378	19,737	7,671	27,408
COMM. DIS. SURV. (106)	0.09	0	7	2,142	2,498	2,142	2,497	9,279	0	9,279
HEPATITIS (109)	0.00	0	0	0	0	0	0	0	0	0
PREPAREDNESS AND RESPONSE (116)	1.15	0	4	40,177	46,861	40,177	46,861	174,076	0	174,076
REFUGEE HEALTH (118)	0.03	0	0	474	552	474	552	1,626	426	2,052
VITAL RECORDS (180)	1.93	5,167	12,185	22,645	26,413	22,645	26,414	3,308	94,809	98,117
COMMUNICABLE DISEASE SUBTOTAL	8.52	7,117	15,345	165,751	193,327	165,751	193,328	448,221	269,936	718,157
B. PRIMARY CARE:										
CHRONIC DISEASE PREVENTION PRO (210)	0.88	208	108	18,193	21,220	18,193	21,221	78,827	0	78,827
WIC (21W1)	0.00	0	0	0	0	0	0	0	0	0
TOBACCO USE INTERVENTION (212)	0.00	0	0	0	0	0	0	0	0	0
WIC BREASTFEEDING PEER COUNSELING (21W2)	0.00	0	0	0	0	0	0	0	0	0
FAMILY PLANNING (223)	2.73	753	1,355	49,355	57,567	49,355	57,566	126,729	87,114	213,843
IMPROVED PREGNANCY OUTCOME (225)	0.00	0	0	16	19	16	19	49	21	70
HEALTHY START PRENATAL (227)	3.70	649	2,987	67,089	78,251	67,089	78,252	0	290,681	290,681
COMPREHENSIVE CHILD HEALTH (229)	0.01	2	2	435	507	435	507	1,095	789	1,884
HEALTHY START CHILD (231)	1.58	223	992	22,616	26,379	22,616	26,380	0	97,991	97,991
SCHOOL HEALTH (234)	0.03	0	108,976	27,253	31,787	27,253	31,787	118,080	0	118,080
COMPREHENSIVE ADULT HEALTH (237)	2.18	554	910	48,440	56,499	48,440	56,500	156,215	53,664	209,879
COMMUNITY HEALTH DEVELOPMENT (238)	0.26	0	19	4,385	5,114	4,385	5,114	18,998	0	18,998
DENTAL HEALTH (240)	4.67	1,203	1,411	91,336	106,532	91,336	106,531	123,495	272,240	395,735
PRIMARY CARE SUBTOTAL	16.04	3,592	116,760	329,118	383,875	329,118	383,877	623,488	802,500	1,425,988
C. ENVIRONMENTAL HEALTH:										
Water and Onsite Sewage Programs										
COSTAL BEACH MONITORING (347)	0.00	0	0	0	0	0	0	0	0	0
LIMITED USE PUBLIC WATER SYSTEMS (357)	1.14	146	2,212	24,882	29,021	24,882	29,021	90,586	17,220	107,806
PUBLIC WATER SYSTEM (358)	0.17	2	2,515	2,520	2,939	2,520	2,938	0	10,917	10,917
PRIVATE WATER SYSTEM (359)	1.01	3	997	16,366	19,089	16,366	19,090	56,461	14,450	70,911
ONSITE SEWAGE TREATMENT & DISPOSAL (361)	4.02	994	2,458	66,034	77,021	66,034	77,021	273,605	12,505	286,110
Group Total	6.34	1,145	8,182	109,802	128,070	109,802	128,070	420,652	55,092	475,744
Facility Programs										
TATTOO FACILITY SERVICES (344)	0.00	0	0	0	0	0	0	0	0	0

ATTACHMENT II

COLUMBIA COUNTY HEALTH DEPARTMENT

Part III, Planned Staffing, Clients, Services and Expenditures By Program Service Area Within Each Level of Service
October 1, 2018 to September 30, 2019

	FTE's (0.00)	Clients Units	Services/ Visits	Quarterly Expenditure Plan				State	County	Grand Total
				1st	2nd (Whole dollars only)	3rd	4th			
FOOD HYGIENE (348)	0.27	69	220	4,766	5,560	4,766	5,560	20,652	0	20,652
BODY PIERCING FACILITIES SERVICES (349)	0.00	0	0	0	0	0	0	0	0	0
GROUP CARE FACILITY (351)	0.05	31	44	792	924	792	924	2,832	600	3,432
MIGRANT LABOR CAMP (352)	0.07	11	11	1,005	1,172	1,005	1,173	4,355	0	4,355
HOUSING & PUB. BLDG. (353)	0.00	0	0	0	0	0	0	0	0	0
MOBILE HOME AND PARK (354)	0.42	317	424	5,758	6,717	5,758	6,717	24,950	0	24,950
POOLS/BATHING PLACES (360)	0.18	42	138	2,771	3,231	2,771	3,231	12,004	0	12,004
BIOMEDICAL WASTE SERVICES (364)	0.00	0	0	0	0	0	0	0	0	0
TANNING FACILITY SERVICES (369)	0.02	10	12	345	403	345	403	1,496	0	1,496
Group Total	1.01	480	849	15,437	18,007	15,437	18,008	66,289	600	66,889
Groundwater Contamination										
STORAGE TANK COMPLIANCE SERVICES (355)	0.00	0	0	0	0	0	0	0	0	0
SUPER ACT SERVICES (356)	0.00	0	0	0	0	0	0	0	0	0
Group Total	0.00	0	0	0	0	0	0	0	0	0
Community Hygiene										
COMMUNITY ENVIR. HEALTH (345)	0.00	0	0	0	0	0	0	0	0	0
INJURY PREVENTION (346)	0.00	0	0	0	0	0	0	0	0	0
LEAD MONITORING SERVICES (350)	0.00	0	0	0	0	0	0	0	0	0
PUBLIC SEWAGE (362)	0.00	0	0	0	0	0	0	0	0	0
SOLID WASTE DISPOSAL SERVICE (363)	0.00	0	0	0	0	0	0	0	0	0
SANITARY NUISANCE (365)	0.08	54	69	1,315	1,534	1,315	1,535	5,699	0	5,699
RABIES SURVEILLANCE (366)	0.26	55	141	4,826	5,628	4,826	5,628	20,908	0	20,908
ARBORVIRUS SURVEIL. (367)	0.00	0	0	0	0	0	0	0	0	0
RODENT/ARTHROPOD CONTROL (368)	0.00	0	0	0	0	0	0	0	0	0
WATER POLLUTION (370)	0.00	0	0	0	0	0	0	0	0	0
INDOOR AIR (371)	0.00	0	0	24	27	24	27	102	0	102
RADIOLOGICAL HEALTH (372)	0.00	0	0	0	0	0	0	0	0	0
TOXIC SUBSTANCES (373)	0.00	0	0	0	0	0	0	0	0	0
Group Total	0.34	109	210	6,165	7,189	6,165	7,190	26,709	0	26,709
ENVIRONMENTAL HEALTH SUBTOTAL	7.69	1,734	9,241	131,404	153,266	131,404	153,268	513,650	55,692	569,342
D. NON-OPERATIONAL COSTS:										
NON-OPERATIONAL COSTS (599)	0.00	0	0	0	0	0	0	0	0	0
ENVIRONMENTAL HEALTH SURCHARGE (399)	0.00	0	0	6,900	8,048	6,900	8,047	29,895	0	29,895
MEDICAID BUYBACK (611)	0.00	0	0	231	269	231	269	1,000	0	1,000
NON-OPERATIONAL COSTS SUBTOTAL	0.00	0	0	7,131	8,317	7,131	8,316	30,895	0	30,895
TOTAL CONTRACT	32.25	12,443	141,346	633,404	738,785	633,404	738,789	1,616,254	1,128,128	2,744,382

ATTACHMENT III
COLUMBIA COUNTY HEALTH DEPARTMENT
CIVIL RIGHTS CERTIFICATE

The applicant provides this assurance in consideration of and for the purpose of obtaining federal grants, loans, contracts (except contracts of insurance or guaranty), property, discounts, or other federal financial assistance to programs or activities receiving or benefiting from federal financial assistance. The provider agrees to complete the Civil Rights Compliance Questionnaire, DH Forms 946 A and B (or the subsequent replacement if adopted during the contract period), if so requested by the department.

The applicant assures that it will comply with:

1. Title VI of the Civil Rights Act of 1964, as amended, 42 U.S.C., 2000 Et seq., which prohibits discrimination on the basis of race, color or national origin in programs and activities receiving or benefiting from federal financial assistance.
2. Section 504 of the Rehabilitation Act of 1973, as amended, 29 U.S.C. 794, which prohibits discrimination on the basis of handicap in programs and activities receiving or benefiting from federal financial assistance.
3. Title IX of the Education Amendments of 1972, as amended, 20 U.S.C. 1681 et seq., which prohibits discrimination on the basis of sex in education programs and activities receiving or benefiting from federal financial assistance.
4. The Age Discrimination Act of 1975, as amended, 42 U.S.C. 6101 et seq., which prohibits discrimination on the basis of age in programs or activities receiving or benefiting from federal financial assistance.
5. The Omnibus Budget Reconciliation Act of 1981, P.L. 97-35, which prohibits discrimination on the basis of sex and religion in programs and activities receiving or benefiting from federal financial assistance.
6. All regulations, guidelines and standards lawfully adopted under the above statutes. The applicant agrees that compliance with this assurance constitutes a condition of continued receipt of or benefit from federal financial assistance, and that it is binding upon the applicant, its successors, transferees, and assignees for the period during which such assistance is provided. The applicant further assures that all contracts, subcontractors, subgrantees or others with whom it arranges to provide services or benefits to participants or employees in connection with any of its programs and activities are not discriminating against those participants or employees in violation of the above statutes, regulations, guidelines, and standards. In the event of failure to comply, the applicant understands that the grantor may, at its discretion, seek a court order requiring compliance with the terms of this assurance or seek other appropriate judicial or administrative relief, to include assistance being terminated and further assistance being denied.

Attachment IV

Fiscal Year - 2018 - 2019

Columbia County Health Department

Facilities Utilized by the County Health Department

Complete Location <small>(Street Address, City, Zip)</small>	Facility Description And Offical Building Name (if applicable) <small>(Admin, Clinic, Envrn Hlth, etc.)</small>	Lease/ Agreement Number	Type of Agreement <small>(Private Lease thru State or County, other - please define)</small>	Complete Legal Name of Owner	SQ Feet	Employee Count <small>(FTE/OPS/ Contract)</small>
217 NE Franklin Street, Lake City, FL 32055	Columbia Main Clinic	012:9002	County Owned	Columbia County	13195	34
535 SW Dortch St., Ft. White, FL 32038	Ft. White Clinic	012:9003	County Leased	Town of Ft. White	1500	3
135 NE Hernando Ave, Lake City, FL 32055	Environmental Health	012:9004	County Owned	Columbia County	1200	5

Facility - a fixed site managed by DOH/CHD personnel for the purpose of providing or supporting public health services. Includes county-owned, state-owned, and leased facilities. Includes DOH/CHD warehouse and administrative sites. Includes facilities managed by DOH/CHD that may be shared with other organizations. Does not include schools, jails or other facilities where DOH/CHD staff are out-posted or sites where services are provided on an episodic basis.

**ATTACHMENT V
COLUMBIA COUNTY HEALTH DEPARTMENT
SPECIAL PROJECTS SAVINGS PLAN**

CASH RESERVED OR ANTICIPATED TO BE RESERVED FOR PROJECTS

<u>CONTRACT YEAR</u>	<u>STATE</u>	<u>COUNTY</u>	<u>TOTAL</u>
2017-2018*	\$ _____ 0	\$ _____ 0	\$ _____ 0
2018-2019**	\$ _____ 0	\$ _____ 0	\$ _____ 0
2019-2020***	\$ _____ 0	\$ _____ 0	\$ _____ 0
2020-2021***	\$ _____ 0	\$ _____ 0	\$ _____ 0
PROJECT TOTAL	\$ _____ 0	\$ _____ 0	\$ _____ 0

SPECIAL PROJECTS CONSTRUCTION/RENOVATION PLAN

PROJECT NUMBER: _____

PROJECT NAME: _____

LOCATION/ADDRESS: _____

PROJECT TYPE:

NEW BUILDING	_____	ROOFING	_____
RENOVATION	_____	PLANNING STUDY	_____
NEW ADDITION	=====	OTHER	_____

SQUARE FOOTAGE: _____ 0

PROJECT SUMMARY: *Describe scope of work in reasonable detail.*

START DATE (Initial expenditure of funds) _____

COMPLETION DATE: _____

DESIGN FEES: \$ _____ 0

CONSTRUCTION COSTS: \$ _____ 0

FURNITURE/EQUIPMENT: \$ _____ 0

TOTAL PROJECT COST: \$ _____ 0

COST PER SQ FOOT: \$ _____ 0

Special Capital Projects are new construction or renovation projects and new furniture or equipment associated with these projects and mobile health vans.

* Cash balance as of 9/30/18
 ** Cash to be transferred to FCO account.
 *** Cash anticipated for future contract years.



COLUMBIA COUNTY BOARD OF COUNTY COMMISSIONERS AGENDA ITEM REQUEST FORM

The Board of County Commissioners meets the 1st and 3rd Thursday of each month at 5:30 p.m. in the Columbia County School Board Administrative Complex Auditorium, 372 West Duval Street, Lake City, Florida 32055. All agenda items are due in the Board's office one week prior to the meeting date.

Today's Date: September 14, 2018 Meeting Date: September 20, 2018

Name: Ben Scott Department: BCC Administration

Division Manager's Signature: *Ben Scott*

1. Nature and purpose of agenda item:

Palms Medical Group - Renewal Contract for Services

Attach any correspondence information, documents and forms for action i.e., contract agreements, quotes, memorandums, etc.

2. Fiscal impact on current budget.

Is this a budgeted item? N/A
 Yes Account No. _____
 No Please list the proposed budget amendment to fund this request

Budget Amendment Number: _____ Fund: _____

FROM: _____ TO: _____ AMOUNT: _____

For Use of County Manager Only:

Consent Item Discussion Item

District No. 1 - Ronald Williams
District No. 2 - Rusty DePratter
District No. 3 - Bucky Nash
District No. 4 - Everett Phillips
District No. 5 - Tim Murphy



BOARD OF COUNTY COMMISSIONERS • COLUMBIA COUNTY

MEMORANDUM

TO: Commissioners

FR: Ben Scott, County Manager *Ben Scott*

DATE: September 12, 2018

SUBJECT: Renew Contract for Services – Palms Medical Group

Please find the attached renewal contract for services by Palms Medical Group for fiscal year 2018-19. The rates have remained the same.

XC: Palms Medical Group

BOARD MEETS FIRST THURSDAY AT 5:30 P.M.
AND THIRD THURSDAY AT 5:30 P.M.

CONTRACT FOR SERVICES

This Contract entered into this 1st day of October 2018 by and between Columbia County, Florida, acting through its Board of County Commissioners, hereinafter called "County" and the Trenton Medical Center, Inc. dba Palms Medical Group hereinafter called "Contractor".

WITNESSETH

That for and in consideration of the sum of FORTY EIGHT THOUSAND FIVE HUNDRED AND NO/100---- \$48,500.00 to be paid by the County to the Contractor in the following manner:

FOUR (4) QUARTERLY INSTALLMENTS OF \$12,125.00

Contractor agrees to furnish the County the following described services from October 1, 2018 to September 30, 2019 in the Columbia County, Florida, which services the County finds will serve a County purpose:

TO PROVIDE HEALTH SERVICES TO THE CITIZENS OF COLUMBIA COUNTY.

Contractor agrees to furnish the county with an annual audit, which meets governmental auditing standards prior to requesting, in writing, first quarterly installments. Contractor also agrees that funding under this contract must be expended in the fiscal year it was allocated or it is forfeited.

The above parties acknowledge Columbia County Board of Commissioners have a general Purchasing policy manual for use by all agencies under their budgetary control. The policy is to award the purchase or contract to the lowest bidder; however, other contributing factors may justify awarding to a higher or more responsible bidder. The bid of a resident of Columbia County Florida may have a 5% preference over the bid submitted by a non-resident of Columbia County, Florida. The Board of County Commissioners reserves the right to award a bid which will be in the best interest of the County.

The parties further acknowledge Columbia County, Florida has no direct or indirect responsibility for management, operation, or other activities or functions of the agency to which Columbia County is contributing funding under the terms of this agreement. As a result thereof, the County shall not be responsible for any acts, omissions, or other actions or failure to act by the agency, which may result in liability to the agency for damages to person or property of a third party. Further, the agency receiving funds under the terms of this agreement hereby agrees to indemnify and hold Columbia County, Florida harmless from any liability for any injury or damage, which may be suffered by either the agency or any third party whether said damage or injury may relate to personal injury, property, or the rights of such third party.

IN WITNESS WHEREOF, the parties hereto have caused these presents to be signed by their duly authorized agents or representatives, the day and year first above mentioned.

**BOARD OF COUNTY COMMISSIONERS
COLUMBIA COUNTY, FLORIDA**

BY: _____

Tim Murphy, Chairman

ATTEST:

BY: _____

P. DeWitt Cason, Clerk of Court

**TRENTON MEDICAL CENTER, INC.
d/b/a PALMS MEDICAL GROUP**

BY: _____

Anita, Riels, CEO



COLUMBIA COUNTY BOARD OF COUNTY COMMISSIONERS AGENDA ITEM REQUEST FORM

The Board of County Commissioners meets the 1st and 3rd Thursday of each month at 5:30 p.m. in the Columbia County School Board Administrative Complex Auditorium, 372 West Duval Street, Lake City, Florida 32055. All agenda items are due in the Board's office one week prior to the meeting date.

Today's Date: September 6, 2018 Meeting Date: September 20, 2018

Name: Penny Stanley Department: BCC Administration

Division Manager's Signature: *Ben Scott*

1. Nature and purpose of agenda item:

BCC Administration - Release of Lien - Suwannee River Economic Council (S.H.I.P.) - Barbara B. Hatcher - \$12,000

Attach any correspondence information, documents and forms for action i.e., contract agreements, quotes, memorandums, etc.

2. Fiscal impact on current budget.

Is this a budgeted item? N/A
 Yes Account No. _____
 No Please list the proposed budget amendment to fund this request

Budget Amendment Number: _____ Fund: _____

FROM: _____ TO: _____ AMOUNT: _____

For Use of County Manager Only:

Consent Item Discussion Item

THIS INSTRUMENT PREPARED BY:

SUBORDINATION AGREEMENT

KNOW ALL MEN BY THESE PRESENTS:

That COLUMBIA COUNTY, FLORIDA a political subdivision existing under the laws of the State of Florida, whose address is c/o Clerk of Circuit Court, Columbia County Courthouse, PO Drawer 1529, Lake City FL 32056, hereinafter referred to as "Mortgagee", in consideration of the covenants and agreements hereinafter set forth, and the further consideration of the making of a loan to **Barbara Blake Hatcher**, whose address is **2480 SW Pinemount Road, Lake City, FL 32024**, hereinafter referred to as "Mortgagor", by **First Guaranty Mortgage Corporation, dba goodmortgage.com, ISAOA ATIMAC/O Rushmore Loan Management Services LLC** whose address is **PO Box 692409, San Antonio, TX 78269**, does hereby agree as follows:

1. Mortgagee subordinates the lien of that certain lien agreement under the State of Florida Housing Initiative Partnership Program given by **Barbara Blake Chapman (now known as Barbara Blake Hatcher)** to Mortgagee dated **May 19, 2017** and recorded in Official Record Book 1337, pages 987-990, public records of Columbia County, Florida, given to secure the sum of **\$12,000.00**, hereinafter referred to as "Mortgagee's Lien" to the lien of that certain mortgage from **Barbara Blake Hatcher, a married woman, herein joined by her spouse, Levi J. Hatcher** to **First Guaranty Mortgage Corporation, dba goodmortgage.com, ISAOA ATIMAC/O Rushmore Loan Management Services LLC**, dated _____, recorded in Official Record Book _____, pages _____, public records of Columbia County, Florida, and given to secure the original principal sum of \$ _____, hereinafter referred to as "**First Guaranty Mortgage Corporation, dba goodmortgage.com, ISAOA ATIMAC/O Rushmore Loan Management Services LLC** Mortgage".
2. In consideration of the subordination, **First Guaranty Mortgage Corporation, dba goodmortgage.com, ISAOA ATIMAC/O Rushmore Loan Management Services LLC** agrees that it shall make no future advances to *Mortgagors* or any successors in interest under **First Guaranty Mortgage Corporation, dba goodmortgage.com, ISAOA ATIMAC/O Rushmore Loan Management Services LLC** so long as the obligation secured by Mortgagee's Lien shall remain outstanding, excepting, however, all necessary costs to protect the security of **First Guaranty Mortgage Corporation, dba goodmortgage.com, ISAOA ATIMAC/O Rushmore Loan Management Services LLC's** Mortgage, including taxes, insurance and similar expenses to preserve and protect **First Guaranty Mortgage Corporation, dba goodmortgage.com, ISAOA ATIMAC/O Rushmore Loan Management Services LLC's** security as well as costs and attorneys' fees that may be incurred in the collection or enforcement of the obligation secured by **First Guaranty Mortgage Corporation, dba goodmortgage.com, ISAOA ATIMAC/O Rushmore Loan Management Services LLC's** Mortgage.
3. **(Insert name of Lending institution)** may, without affecting the priority of **(insert name of Lending institution)'s** Mortgage, one or more times, in its judgment, renew, extend, modify, postpone and/or

refinance the obligation secured by (insert name of Lending institution)'s Mortgage, grant releases and discharges generally and make changes in the terms of (insert name of Lending institution)'s Mortgage without notice to or approval of Mortgagee herein, provided that the total amount secured by First Guaranty Mortgage Corporation, dba goodmortgage.com, ISAOA ATIMAC/O Rushmore Loan Management Services LLC's Mortgage shall not exceed \$103,630.00 in amount with interest thereon, and sums that First Guaranty Mortgage Corporation, dba goodmortgage.com, ISAOA ATIMAC/O Rushmore Loan Management Services LLC may advance to protect the security and enforce payment thereof, as aforesaid.

- 4. Except as herein specifically provided, the term, condition and covenants of the Mortgagee's Lien shall remain unchanged.

IN WITNESS WHEREOF, Columbia County, Florida, a political sub-division existing under the laws of the State of Florida, has caused these presents to be executed this _____ day of _____, 2018.

Signed, Sealed, and Delivered
in the presence of:

COLUMBIA COUNTY, FLORIDA

BY: _____
DeWitt Cason
Clerk of Court, Columbia County FL

STATE OF FLORIDA
COUNTY OF COLUMBIA

The foregoing release and satisfaction of lien agreement under State of Florida Housing Initiatives Partnership Program was acknowledged before me this _____ day of _____, 2018, by DeWitt Cason, Clerk of Court, Columbia County, FL, who is personally known to me.

(NOTARIAL SEAL)

Notary Public

Print or Type name of Notary
My Commission Expires:



COLUMBIA COUNTY BOARD OF COUNTY COMMISSIONERS AGENDA ITEM REQUEST FORM

The Board of County Commissioners meets the 1st and 3rd Thursday of each month at 5:30 p.m. in the Columbia County School Board Administrative Complex Auditorium, 372 West Duval Street, Lake City, Florida 32055. All agenda items are due in the Board's office one week prior to the meeting date.

Today's Date: September 7, 2018 Meeting Date: September 20, 2018

Name: Penny Stanley Department: BCC Administration

Division Manager's Signature: 

1. Nature and purpose of agenda item:

BCC Administration - Minutes - Board of County Commissioners - Regular Meeting - September 6, 2018

Attach any correspondence information, documents and forms for action i.e., contract agreements, quotes, memorandums, etc.

2. Fiscal impact on current budget.

Is this a budgeted item? N/A
 Yes Account No. _____
 No Please list the proposed budget amendment to fund this request

Budget Amendment Number: _____ Fund: _____

FROM: _____ TO: _____ AMOUNT: _____

For Use of County Manager Only:

Consent Item Discussion Item

Columbia County
Board of County Commissioners

Minutes of
September 6, 2018

The Columbia County Board of County Commissioners met in a regular meeting at the auditorium of the School Board Administrative Complex at 5:30 p.m. The meeting opened with prayer and the Pledge of Allegiance to the Flag of the United States of America.

Commissioners in Attendance: Chairman Timothy Murphy, Rusty DePratter, Bucky Nash, Everett Phillips and Ronald Williams.

Others in Attendance: County Manager Ben Scott ("CM")
Assistant County Manager David Kraus ("ACM")
Assistant County Manager Kevin Kirby ("ACM")
County Attorney Joel Foreman
BOCC Finance Director Danielle Beard
Deputy Clerk Katrina Vercher

Agenda Additions/Deletions

Additions:

- Mosquito Control Budget
- Handicap door at Fort White Sub Station

Deletions:

None

MOTION by Commissioner Nash to approve the agenda with additions.
SECOND by Commissioner Williams. The motion carried unanimously.

Ministerial Matters

Proclamation No. 2018P-6

Commissioner Murphy read the Proclamation recognizing the Impact Baseball Team for their hard work, dedication, sportsmanship and teamwork.

MOTION by Commissioner DePratter to approve Proclamation 2018P-6.
SECOND by Commissioner Phillips. The motion carried unanimously.

Century Ambulance 2017 Emergency Medical Services Report

Steven Stith, Regional Director for Century Ambulance, presented the Board with the 2017 Columbia County EMS Report.

Public Hearings

Country Lakes in Woodborough, Phase 5

SD 0181 – A request for approval of a minor subdivision plat for tax parcel 02267-135.

The public hearing opened and closed without comment.

MOTION by Commissioner Nash to approve SD 0181. SECOND by Commissioner Williams. The motion carried unanimously.

Community Development Block Grant (“CDBG”)

ACM Kraus would like to apply for the CDBG grant to help fund the expansion of the wastewater treatment plant in Ellisville. The plant is operating at around 75% capacity and additional growth in the area will require an expansion to the plant. This is the first of two required public hearings. Staff would like to receive comment on the needs of that community.

Discussion ensued.

Ordinance No. 2018-15 – Aloe Court and Merrimack Place

An ordinance amending the County Code of Ordinances to add Aloe Court and Merrimack Place to the list of County roads which allow the operation of golf carts.

The public hearing opened and closed without comment.

MOTION by Commissioner Nash to adopt Ordinance No. 2018-15. SECOND by Commissioner DePratter. The motion carried unanimously.

Ordinance No. 2018-16 – Court Costs

An ordinance amending chapter 38, article II, division 7 of the county code of ordinances to conform the count’s code with state law.

The public hearing opened and closed without comment.

MOTION by Commissioner Williams to adopt Ordinance No. 2018-16. SECOND by Commissioner Phillips. The motion carried unanimously.

Final Rate Hearings:

Resolution No. 2018R – 32 – Fire Protection Services Assessment

A Resolution reimposing Fire Protection Assessments against assessable property within the Columbia County Municipal Services Benefit Unit for the Fiscal Year beginning October 1, 2018.

The public hearing opened and closed without comment.

MOTION by Commissioner Nash to adopt Resolution No. 2018R-32. SECOND by Commissioner Phillips. The motion carried 4 to 1 with Commissioner Williams voting in opposition.

Resolution No. 2018R – 33 – Solid Waste Service Assessment

A Resolution reimposing Solid Waste Assessments against assessable property within the Columbia County Municipal Services Benefit Unit for the Fiscal Year beginning October 1, 2018. There are no rate changes.

The public hearing opened and closed without comment.

MOTION by Commissioner Williams to adopt Resolution No. 2018R-33. SECOND by Commissioner DePratter. The motion carried unanimously.

Resolution No. 2018R – 34 – Emerald Lakes Street Lighting Services Assessment

A Resolution reimposing Emerald Lakes Street Lighting Services Assessments against assessable property, pursuant to the Uniform Assessment Collection Act, for the Fiscal Year beginning October 1, 2018. There are no rate changes.

The public hearing opened and closed without comment.

MOTION by Commissioner Nash to adopt Resolution No. 2018R-34. SECOND by Commissioner Phillips. The motion carried unanimously.

Resolution No. 2018R – 35 – Spring Hollow Street Lighting Services Assessment

A Resolution reimposing Spring Hollow Street Lighting Services Assessments against assessable property within the Columbia County Municipal Services Benefit Unit for the Fiscal Year beginning October 1, 2018. There are no rate changes.

The public hearing opened and closed without comment.

MOTION by Commissioner Williams to adopt Resolution No. 2018R-35. SECOND by Commissioner Phillips. The motion carried unanimously.

Resolution No. 2018R – 36 – Carolyn Heights Street Lighting Services Assessment

A Resolution imposing Carolyn Heights Street Lighting Services Assessments against assessable property within the Columbia County Municipal Services Benefit Unit for the Fiscal Year beginning October 1, 2018. This is a new assessment.

The public hearing opened and closed without comment.

MOTION by Commissioner Williams to adopt Resolution No. 2018R-36 with a notation that staff is going to reimburse those residents from last year where we did not have the full lighting service in place and they still paid that assessment. It will be prorated out from the time it went online and those customers paid their money back. SECOND by Commissioner Phillips.

Discussion ensued.

The Chairman called for the vote. The motion carried unanimously.

Resolution No. 2018R – 37 – Pine Ridge Court Road Improvement Project

A Resolution reimposing Pine Ridge Court Maintenance Services and Road Improvement Project Assessments against assessable property, pursuant to the Uniform Assessment Collection Act, for the Fiscal Year beginning October 1, 2017.

The public hearing opened and closed without comment.

MOTION by Commissioner DePratter to adopt Resolution No. 2018R-37. SECOND by Commissioner Williams. The motion carried unanimously.

Resolution No. 2018R – 38 – Rolling Oaks Paving Project

A Resolution reimposing Rolling Oaks Paving Project Assessments against assessable property, within the Columbia County Municipal Services Benefit Unit for the Fiscal Year beginning October 1, 2018.

The public hearing opened and closed without comment.

MOTION by Commissioner Nash to adopt Resolution No. 2018R-38. SECOND by Commissioner Phillips. The motion carried unanimously.

First Budget Hearing:

CM Scott briefly explained the County's budget process.

Millage Rate for Fiscal Year 2018-2019

CM Scott presented a budget comparison for the 2018-2019 Fiscal Year, using two different millage rates; 8.8700 and 8.0150.

Discussion ensued.

The public hearing opened.

The following citizens offered comment or asked questions:

Louis Munoz	Bonnie Foster	Bruce Borders
Sherry Justin	Barbara Lemley	Merrilee Malwitz-Jipson
James Parnell	Stewart Lilker	

The public hearing closed.

Discussion ensued.

MOTION by Commissioner DePratter to adopt and set tentative millage rate of 8.0150 mills for the 2018-2019 Fiscal Year. SECOND by Commissioner Williams.

AMENDED MOTION by Commissioner DePratter to adopt and set tentative millage rate of 8.0150 mills for the 2018-2019 Fiscal Year which is 3.4% higher than the rolled back rate of 7.7511. AMENDED SECOND by Commissioner Williams. The motion carried unanimously.

General Fund Budget for Fiscal Year 2018-2019

CM Scott listed the offices and departments that are funded from the General Fund and announced that the total proposed budget for the 2018-2019 Fiscal Year is \$39,884,181.

The public hearing opened.

The following citizens offered comment or asked questions:

Crista Pribble	Louis Munoz	Stewart Lilker
----------------	-------------	----------------

The public hearing closed.

MOTION by Commissioner DePratter to adopt a tentative general fund budget, appropriations and reserves budget at \$39,884,181. SECOND by Commissioner Williams. The motion carried unanimously.

Funds not Levying Ad-Valorem Budgets for Fiscal Year 2018-2019

CM Scott listed the funds that do not levy Ad-Valorem taxes.
The public hearing opened.

The following citizens offered comment or asked questions:
Stewart Lilker

The public hearing closed.

MOTION by Commissioner DePratter to adopt tentative budgets, appropriations and reserves budget for the following funds:

Transportation Trust	\$ 12,616,935
Municipal Services Fund	15,039,142
Sheriff	19,231,267
Court Services	979,350
Landfill Enterprise	9,525,839
Library Enhancement	2,299,630
Special Law Enforcement	21,300
Tourist Development Tax-Operating	4,293,750
Local Housing Assistance	370,000
Economic Development	1,280,425
Utilities	391,310
CDBG	750,000
Paving Assessment	192,340
Road Improvement	13,233,263
Capital Projects	10,560,000
Jail Construction	11,435,000
Road Improvement Debt Service	782,750
Jail Debt Service	977,450

SECOND by Commissioner Williams. The motion carried unanimously.

Final Budget Hearing Notice

The Final Budget Hearing for the Fiscal Year 2018-2019 Budget will be held on September 20, 2018 at the regular scheduled meeting.

Consent Agenda:

MOTION by Commissioner Williams to approve the consent agenda. SECOND by Commissioner Phillips. The motion carried unanimously.

- (1) BCC Administration - BA 18-65 - Transfer Reserves from Sheriff's Special Revenue Fund for Mandated School Resource Officer Deputy Program - \$225,000

- (2) BCC Administration - BA 18-66 - Clerk's Record Storage \$20,000
- (3) BCC Administration - Fort White High School - Fireworks Display - November 1, 2018
- (4) BCC Administration - Pinemount Elementary School - Westside Community Center as Evacuation Site
- (5) BCC Administration - University of Florida - Notice of the Preliminary Estimate of the Permanent Population
- (6) BCC Administration - Minutes - Board of County Commissioners - Regular Meeting - August 16, 2018
- (7) BCC Administration - Minutes - Board of County Commissioners - Special Meeting - August 23, 2018
- (8) BCC Administration - North Central Florida Regional Planning Council - FY 2019 Agreement - Local Government Comprehensive Planning Services - \$35,000
- (9) BCC Administration - North Central Florida Regional Planning Council - FY 2019 - Agreement - Annual Monitoring of Hazardous Waste Generators - \$9,731
- (10) Building And Zoning - Special Family Lot Permit (SFLP 18-30) Joseph Harris, Grandson - Earnest Brown, Property Owner - 1135 SW Scrubtown Road
- (11) Clerk to Board Finance - Payment of Bills and Vouchers - \$1,220,677
- (12) Information Technology - Comcast Contract - Fire Station 51 - 36 months at \$125 per month
- (13) Library - Certification of Credentials - Single Library Administrative Head
- (14) Library - Annual Plan of Service - Fiscal Year 2018 – 2019
- (15) Public Works - Utility Permit - AT&T - Suwannee Valley Road
- (16) Public Works - Utility Permit - Comcast - SW Paloma Court
- (17) Public Works - Utility Permit - Comcast - Gull Drive
- (18) Public Works - Utility Permit - Comcast - Bascom Norris Drive
- (19) Public Works - Enter Private Property - 1475 Sebastian Circle - John Robertson, Property Owner - Driveway Repair

- (20) Public Works - Cardboard Recycling Bin - Columbia County Fair Grounds - \$1,441
- (21) Solid Waste - BA 18-67 - Mosquito Control Budget Amendment

MOTION by Commissioner Williams to adopt the consent agenda.
SECOND by Commissioner Phillips. The motion carried unanimously.

Discussion and Action Items:

Fiscal Year 2018-2019 Mosquito Control Budget

Mosquito Control is requesting approval of the 2018-2019 budget. They must have an approved budget to the Florida Department of Agriculture and Consumer Services by September 15, 2018.

MOTION by Commissioner Williams to approve the Mosquito Control budget .
SECOND by Commissioner DePratter. The motion carried unanimously.

BA 18-64 Sports Feasibility Study Contract

A flat field feasibility study was recommended in the strategic plan. The project was put out to bid and the Sports Marketing Director, Alden Rosner, is requesting approval of the contract with Sports Facility Advisory in the amount of \$42,850 and a budget amendment to move the money from reserves to Sports Marketing/Professional Services to pay the contract.

Discussion ensued.

MOTION by Commissioner Williams to approve BA 18-64 in the amount of \$42,850. SECOND by Commissioner Nash.

Discussion ensued.

The Chairman called for the vote. The motion carried unanimously.

BOCC/CCSO Interlocal Agreement

This Board (“BOCC”) and the Columbia County Sheriff’s Office (“CCSO”) have been attempting to reach an Interlocal Agreement for the continued operation of the Combined Communications Center. Sheriff Hunter requested the help of the County Attorney. Because it is a negotiation between the Board and the Sheriff, it would be a conflict of interest for Mr. Foreman without the Board and the Sheriff execute a joint waiver of conflict and allow Mr. Foreman to mediate.

Discussion ensued.

Citizens Stewart Lilker and Louis Munoz offered comment.

MOTION by Commissioner Nash to have Mr. Foreman mediate. SECOND by Commissioner Williams.

Discussion ensued.

Sheriff Hunter addressed the Board.

The Chairman called for the vote. The motion carried unanimously.

Realignment of Union Park Road

Staff received a request from Citizen Thomas Demas that a portion of Union Park Road be abandoned and realigned. Mr. Demas has been in contact with the other property owners that would be affected and he is willing to pay the construction costs associated with the road realignment. Board gave staff direction for Mr. Demas to pay all costs associated with road realignment and future road closure.

Discussion ensued.

Storm Debris Policy

The purpose of this policy is to provide the citizens and taxpayers of Columbia County with an equal opportunity of access to County services, and to avoid duplicative and often costly return trips to retrieve storm debris deposited into the right-of-way.

Discussion ensued.

MOTION by Commissioner Nash to adopt the organic storm debris policy. SECOND by Commissioner DePratter.

Discussion ensued.

Mr. Foreman was directed to prepare an ordinance outlining the penalties for violation of this policy to bring back to this Board for approval.

The Chairman called for the vote. The motion carried unanimously.

Handicap Door at Fort White Sub Station

Commissioner DePratter received a letter from Ronnie Brannon, Columbia County Tax Collector, concerning the lack of an automatic door for the handicap at the Fort White Sub-Station.

Discussion ensued.

MOTION by Commissioner DePratter to install the automatic door. SECOND by Commissioner Williams. The motion carried unanimously.

Open Public Comments and/or Questions:

Members of the public addressed the Board with their comments and/or questions regarding the following items:

- Barbara Lemley concerning recycling.
- Merrilee Malwitz-Jipson concerning flooding at Buzzards Roost.
- Stewart Lilker concerning flooding.

Staff Comments:

County Attorney Foreman addressed the memo he drafted concerning motions as laid out in the Board policy.

Commissioner Comments:

Commissioner Phillips congratulated Commissioners Elect Toby Witt and Rocky Ford.

Commissioner Murphy spoke about the Infrastructure Tax. He also addressed the monies that were approved for an engineering office. Staff was directed to research the purchase of a modular to fill that need and prepare an RFP for Board approval.

Adjournment

There being no further business, the meeting adjourned at 8:45 p.m.

ATTEST:

Timothy Murphy, Chairman
Board of County Commissioners

P. DeWitt Cason
Clerk of Circuit Court



COLUMBIA COUNTY BOARD OF COUNTY COMMISSIONERS
AGENDA ITEM REQUEST FORM

The Board of County Commissioners meets the 1st and 3rd Thursday of each month at 5:30 p.m. in the Columbia County School Board Administrative Complex Auditorium, 372 West Duval Street, Lake City, Florida 32055. All agenda items are due in the Board's office one week prior to the meeting date.

Today's Date: September 5, 2018 Meeting Date: September 20, 2018

Name: Jan Smithey Department: BCC Administration

Division Manager's Signature: Ben Scott

1. Nature and purpose of agenda item:

Summers Elementary - Evacuation Site

Attach any correspondence information, documents and forms for action i.e., contract agreements, quotes, memorandums, etc.

2. Fiscal impact on current budget.

Is this a budgeted item? [X] N/A [] Yes Account No. [] No Please list the proposed budget amendment to fund this request

Budget Amendment Number: Fund:

FROM: TO: AMOUNT:

For Use of County Manager Only:

[X] Consent Item [] Discussion Item



**Columbia County Schools
Summers Elementary**

1388 SW McFarlane Avenue
Lake City, Florida 32025-6599
(386) 755-8250
FAX 386-758-4916

SUPERINTENDENT
ALEX L. CARSWELL, JR

ASSISTANT SUPERINTENDENTS
CHERIE HILL
TODD WIDERGREN

PRINCIPAL
JENNIFER SAUCER

ASSISTANT PRINCIPAL
BRANDI KEEN

September 5, 2018

To Whom It May Concern,

I am in the process of updating our Crisis Response Manual at Summers Elementary. As you know, Southside Sports Complex Coaches' Building has been listed as our secondary off-campus evacuation site. We would love to continue this for the 2018-2019 school year. Please sign and return this letter to show that you are still willing to be an off-campus evacuation site and return to me by September 12, 2018. We appreciate your partnership with our school and look forward to working with you again.

Thanks,

Brandi Keen
Assistant Principal

Southside Sports Complex/Coaching Building can be the secondary off-campus evacuation site for Summers Elementary.

Signature

Date

The Columbia County School District does not discriminate on the basis of race, color, religion, national origin, gender, age disability or marital status in its educational programs, services or activities, or in its hiring or employment practices. The district also provides equal access to its facilities to the Boy Scouts and other patriotic youth groups, as required by the Boy Scouts of America Equal Access Act. Questions, complaints, or requests for additional information regarding discrimination or harassment may be sent to: Cherie Hill Columbia County School District Equity Officer (386) 755-8015.



COLUMBIA COUNTY BOARD OF COUNTY COMMISSIONERS AGENDA ITEM REQUEST FORM

The Board of County Commissioners meets the 1st and 3rd Thursday of each month at 5:30 p.m. in the Columbia County School Board Administrative Complex Auditorium, 372 West Duval Street, Lake City, Florida 32055. All agenda items are due in the Board's office one week prior to the meeting date.

Today's Date: September 7, 2018 Meeting Date: September 20, 2018

Name: Danielle Beard Department: Clerk to Board Finance

Division Manager's Signature: 

1. Nature and purpose of agenda item:

This item requests Board approval for the payment of bills and vouchers in the amount of \$1,796,031.12 submitted September 5, 2018. All funds authorized for the issuance of these checks have been budgeted. The Clerk to Board office reviews bills and vouchers submitted for approval. If for any reason, any of these bills are not recommended for approval, the Clerk to Board office will notify the Board. Copies of invoices and supporting documentation are maintained in the Clerk to Board office for review.

Attach any correspondence information, documents and forms for action i.e., contract agreements, quotes, memorandums, etc.

2. Fiscal impact on current budget.

Is this a budgeted item? N/A
 Yes Account No. various
 No Please list the proposed budget amendment to fund this request

Budget Amendment Number: _____ Fund: _____

FROM: _____ TO: _____ AMOUNT: _____

For Use of County Manager Only:

Consent Item Discussion Item

CHECK NUMBER	VENDOR NUMBER	SEQ#	VENDOR NAME	CHECK DATE	CHECK AMOUNT	DISCOUNTS/RETAINAGE TAKEN
25850	2013	00	A T & T	09/05/2018	771.59	.00
25851	5231	00	ALDEN ROSNER	09/05/2018	121.00	.00
25852	101	00	ALLEN, NORTON & BLUE, P.A.	09/05/2018	125.46	.00
25853	8287	00	AMERICAN VAN	09/05/2018	2,174.25	.00
25854	111	00	ANDERSON COLUMBIA CO., INC.	09/05/2018	3,765.52	.00
25855	3553	00	ASHTIN COMMUNICATIONS	09/05/2018	440.00	.00
25856	3172	00	AT & T PRO CLUB	09/05/2018	723.87	.00
25857	3368	00	AT & T	09/05/2018	1,470.26	.00
25858	3637	00	AT & T PRO-CABS/IBS	09/05/2018	1,792.10	.00
25859	8195	00	AT&T	09/05/2018	28.24	.00
25860	251	00	BAKER DISTRIBUTING CO.	09/05/2018	99.90	.00
25861	3089	00	BANK OF AMERICA	09/05/2018	3,521.56	.00
25862	5251	00	BATTERIES PLUS	09/05/2018	226.75	.00
25863	4015	00	BAYWAY SERVICE	09/05/2018	325.00	.00
25864	3643	00	BEARD EQUIPMENT CO. INC.	09/05/2018	4,841.78	.00
25865	4680	00	BLUE SUMMIT WATERS, LLC	09/05/2018	591.45	.00
25866	237	00	BOAF	09/05/2018	255.80	.00
25867	3893	00	BOONE IMPROVEMENTS INC.	09/05/2018	21,912.63	.00
25868	3914	00	BRENT HAYDEN, M.D. P.A.	09/05/2018	270.00	.00
25869	4636	00	C & C DISCOUNT PARTS	09/05/2018	690.00	.00
25870	1796	00	CAROLYN HEIGHTS WATER CO., INC.	09/05/2018	40.19	.00
25871	348	00	CENTRAL STATES ENTERPRISE, INC.	09/05/2018	286.90	.00
25872	2501	00	CINTAS CORPORATION #148	09/05/2018	1,733.39	.00
25873	382	00	CITY ELECTRIC SUPPLY, INC.	09/05/2018	221.95	.00
25874	304	00	CITY OF LAKE CITY - UTILITIES	09/05/2018	3,193.28	.00
25875	308	00	CLAY ELECTRIC COOPERATIVE, INC.	09/05/2018	1,161.49	.00
25876	352	00	CLERK OF COURT COLUMBIA COUNTY	09/05/2018	10.00	.00
25877	321	00	COLUMBIA COUNTY HEALTH DEPT.	09/05/2018	450.00	.00
25878	2039	00	SHERIFF COLUMBIA COUNTY	09/05/2018	1,188,101.00	.00
25879	2822	00	COMCAST	09/05/2018	530.85	.00
25880	353	00	COMCAST BUSINESS	09/05/2018	5,956.90	.00
25881	4830	00	COMCAST CABLE COMMUNICATIONS, INC.	09/05/2018	104.85	.00
25882	3614	00	CO2 DIRECT GAS, INC.	09/05/2018	578.95	.00
25883	361	00	CURRENT PROBLEMS, INC.	09/05/2018	2,500.00	.00
25884	440	00	DELL MARKETING L.P.	09/05/2018	1,656.16	.00
25885	442	00	DEPT. OF MANAGEMENT SERVICES	09/05/2018	6,614.83	.00
25886	977	00	DISH NETWORK, LLC	09/05/2018	180.04	.00
25887	1256	00	DONALD F. LEE & ASSOC, INC.	09/05/2018	27,232.32	.00
25888	615	00	DUKE ENERGY	09/05/2018	26.08	.00
25889	5267	00	ERIC'SONS, INC.	09/05/2018	1,973.77	.00
25890	534	00	EVACHEK'S TREE SERVICE	09/05/2018	986.00	.00
25891	3193	00	FIRE SERVICE TESTING COMPANY	09/05/2018	1,140.00	.00
25892	4250	00	FLAGLER CONSTRUCTION EQUIPMENT LLC	09/05/2018	523.26	.00
25893	642	00	FLORIDA PEST CONTROL	09/05/2018	355.00	.00
25894	613	00	FLORIDA POWER & LIGHT	09/05/2018	645.17	.00
25895	5280	00	FLORIDA 911 COORDINATORS ASSOC. INC	09/05/2018	40.00	.00
25896	4154	00	FORT WHITE TRUE VALUE HARDWARE	09/05/2018	107.55	.00
25897	700	00	G & K NURSERY	09/05/2018	2,054.50	.00
25898	806	00	G.W. HUNTER, INC.	09/05/2018	58,485.72	.00
25899	702	00	GALLS, LLC	09/05/2018	246.66	.00
25900	759	00	GATEWAY-FOREST LAWN FUNERAL HOME, IN	09/05/2018	900.00	.00

CHECK NUMBER	VENDOR NUMBER	SEQ#	VENDOR NAME	CHECK DATE	CHECK AMOUNT	DISCOUNTS/RETAINAGE TAKEN
25901	754	00	GRAHAM & SONS ELECTRICAL, INC.	09/05/2018	375.00	.00
25902	745	00	GREAT AMERICA FINANCIAL SVCS	09/05/2018	218.45	.00
25903	794	00	GREEN'S MARINE & SPORTING GOODS	09/05/2018	1,170.04	.00
25904	4804	00	HAWKINS, INC.	09/05/2018	313.20	.00
25905	810	00	HEARTLAND REHAB. SERV. FLORIDA,LLC	09/05/2018	175.00	.00
25906	5269	00	HIGH PERFORMANCE CYCLES	09/05/2018	1,535.82	.00
25907	818	00	HILL MANUFACTURING CO., INC.	09/05/2018	438.00	.00
25908	896	00	HOBART SERVICE	09/05/2018	52.58	.00
25909	2133	00	HOME DEPOT CREDIT SERVICE/THE	09/05/2018	686.32	.00
25910	3982	00	HOPPING GREEN & SAMS	09/05/2018	3,132.00	.00
25911	952	00	ICS CREMATION AND FUNERAL HOME	09/05/2018	450.00	.00
25912	2607	00	JOHNSON CONTROLS, INC.	09/05/2018	120,000.00	.00
25913	1102	00	KEATON LOCKSMITHS	09/05/2018	825.00	.00
25914	874	00	KENNY MOORE ELECTRIC, LLC	09/05/2018	675.00	.00
25915	1968	00	KIMI ROBERTS	09/05/2018	7.12	.00
25916	4773	00	KNOX COMPANY	09/05/2018	1,634.00	.00
25917	5026	00	LAKE AND WETLAND MAMAGEMENT	09/05/2018	527.00	.00
25918	1212	00	LAKE CITY AUTO PARTS	09/05/2018	518.83	.00
25919	1224	00	LAKE CITY HUMANE SOCIETY, INC.	09/05/2018	27,500.00	.00
25920	1836	00	LC/CC YOUTH BASEBALL	09/05/2018	12,000.00	.00
25921	3020	00	LEVY JONES	09/05/2018	154.91	.00
25922	1262	00	LOWE'S PROX	09/05/2018	877.48	.00
25923	4621	00	MAILFINANCE	09/05/2018	678.00	.00
25924	5213	00	MAIN STREET PRINTING	09/05/2018	30.00	.00
25925	1317	00	HENRY SHEIN, INC./DBA MATRX MEDICAL	09/05/2018	557.58	.00
25926	5209	00	MAULDIN INTERNATIONAL TRUCKS	09/05/2018	696.22	.00
25927	1319	00	MCCRIMON'S OFFICE SUPPLY	09/05/2018	348.05	.00
25928	1351	00	METAL MASTERS OF FLORIDA INC.	09/05/2018	703.75	.00
25929	1346	00	MIKELL'S POWER EQUIPMENT	09/05/2018	11.72	.00
25930	1347	00	MINI-STORAGE/RECORD STORAGE OF	09/05/2018	45.00	.00
25931	1335	00	MOORE BASS CONSULTING	09/05/2018	19,600.00	.00
25932	1333	00	MORRELL'S	09/05/2018	2,496.00	.00
25933	2493	00	NATIONAL ACADEMY OF EMERGENCY	09/05/2018	235.00	.00
25934	4820	00	NATIONAL ASSOCIATION OF SPORTS	09/05/2018	499.00	.00
25935	1401	00	NATURCHEM, INC.	09/05/2018	46,000.00	.00
25936	1434	00	NE-RO TIRE & BRAKE SERVICE	09/05/2018	3,141.03	.00
25937	1429	00	NEXTRAN TRUCK CENTER	09/05/2018	194.94	.00
25938	3435	00	NORTH FLORIDA ECONOMIC	09/05/2018	10,000.00	.00
25939	1439	00	NORTH FLORIDA FENCE	09/05/2018	11,933.00	.00
25940	3663	00	NORTH FLORIDA PROFESSIONAL SERVICES	09/05/2018	17,710.00	.00
25941	1460	00	BLUETARP FINANCIAL	09/05/2018	117.00	.00
25942	1622	00	OFFICE DEPOT	09/05/2018	1,202.97	.00
25943	1707	00	PELONI'S PUMPING	09/05/2018	1,600.00	.00
25944	3257	00	PESTMASTER	09/05/2018	350.00	.00
25945	1041	00	PETE OLIN AUTO PARTS, INC.	09/05/2018	364.52	.00
25946	1193	00	PETTY CASH (JEFF CRAWFORD)	09/05/2018	32.99	.00
25947	4566	00	PETTYS ASPHALT	09/05/2018	2,300.00	.00
25948	2314	00	POWER SECURE SERVICE, INC.	09/05/2018	470.00	.00
25949	4063	00	PREMIER PAPER & JANITORIAL SUPPLIES	09/05/2018	788.13	.00
25950	1793	00	PREMIER WATER & ENERGY TEC.	09/05/2018	598.00	.00
25951	1763	00	PUBLIC DEFENDER	09/05/2018	683.00	.00

CHECK NUMBER	VENDOR NUMBER	SEQ#	VENDOR NAME	CHECK DATE	CHECK AMOUNT	DISCOUNTS/RETAINAGE TAKEN
25952	1175	00	PUBLIC DEFENDER I.T.	09/05/2018	2,010.00	.00
25953	1802	00	QUADMED, INC.	09/05/2018	1,018.90	.00
25954	1812	00	QUALITY EQUIPMENT & PARTS, INC.	09/05/2018	95.00	.00
25955	4555	00	QUEST LINER	09/05/2018	1,115.40	.00
25956	8033	00	RICKEY W .SMITH	09/05/2018	2,800.00	.00
25957	4644	00	RICKY RESCUE TRAINING ACADEMY	09/05/2018	200.00	.00
25958	4199	00	RING INVESTMENTS, LLC	09/05/2018	87,343.20	.00
25959	1907	00	RING POWER CORP.	09/05/2018	2,443.03	.00
25960	1979	00	ROBERT CANCIGLIA	09/05/2018	9.99	.00
25961	2960	00	ROBERT L. BOSTIC	09/05/2018	1,200.00	.00
25962	3068	00	RUES MARKETING	09/05/2018	53.28	.00
25963	4957	00	SANTA FE BABE RUTH SOFTBALL, INC.	09/05/2018	5,000.00	.00
25964	2021	00	SHERWIN-WILLIAMS CO.STORE#2741	09/05/2018	197.51	.00
25965	4857	00	STRICTLY TECHNOLOGY LLC	09/05/2018	6,067.91	.00
25966	4888	00	SUN PROFESSIONAL SUPPLY, LLC	09/05/2018	365.00	.00
25967	2028	00	SUWANNEE VALLEY ELECT. CO.	09/05/2018	3,342.25	.00
25968	2078	00	SWIFT LUBE	09/05/2018	105.17	.00
25969	4150	00	TARGET SPECIALTY PRODUCTS	09/05/2018	29.16	.00
25970	2163	00	TEEKO GRAPHICS	09/05/2018	2,821.10	.00
25971	2147	00	TEN-8 FIRE EQUIPMENT INC.	09/05/2018	7,926.32	.00
25972	2220	00	THE STORE	09/05/2018	204.47	.00
25973	2176	00	THOMAS HARDWARE FARM & LUMBER, INC.	09/05/2018	10.68	.00
25974	2148	00	THOMAS TIRE REPAIR & ROAD SERVICE	09/05/2018	346.15	.00
25975	2109	00	TOWN OF FT. WHITE	09/05/2018	179.13	.00
25976	4180	00	ULINE	09/05/2018	853.58	.00
25977	4909	00	UNITED REFRIGERATION, INC.	09/05/2018	2,080.20	.00
25978	4922	00	UNIVERSAL ENVIRONMENTAL SERVICES	09/05/2018	75.00	.00
25979	4475	00	UNIVERSAL SIGNS & ACCESSORIES	09/05/2018	459.00	.00
25980	3817	00	USABLUEBOOK	09/05/2018	741.65	.00
25981	3050	00	VOICE FOR CHILDREN	09/05/2018	69.24	.00
25982	2462	00	WHITEHEAD HARDWARE COMPANY	09/05/2018	26.99	.00
25983	129	00	WINDSTREAM	09/05/2018	711.92	.00
25984	5190	00	WINSUPPLY	09/05/2018	204.77	.00
25985	2404	00	WSMDD LAND TRUST	09/05/2018	16,524.99	.00
25986	2500	00	XEROX CORP	09/05/2018	564.51	.00
NUMBER OF CHECKS				137	GRAND TOTAL	1,796,031.12



COLUMBIA COUNTY BOARD OF COUNTY COMMISSIONERS
AGENDA ITEM REQUEST FORM

The Board of County Commissioners meets the 1st and 3rd Thursday of each month at 5:30 p.m. in the Columbia County School Board Administrative Complex Auditorium, 372 West Duval Street, Lake City, Florida 32055. All agenda items are due in the Board's office one week prior to the meeting date.

Today's Date: September 13, 2018 Meeting Date: September 20, 2018

Name: Glenn Hunter Department: Economic Development

Division Manager's Signature: [Handwritten Signature]

1. Nature and purpose of agenda item:

Economic Development - To Amend and Restate Resolution approving Project 18-19 as a Qualified Target Industry.

Attach any correspondence information, documents and forms for action i.e., contract agreements, quotes, memorandums, etc.

2. Fiscal impact on current budget.

Is this a budgeted item? [X] N/A [] Yes Account No. [] No Please list the proposed budget amendment to fund this request

Budget Amendment Number: Fund:

FROM: TO: AMOUNT:

For Use of County Manager Only:

[X] Consent Item [] Discussion Item

District No. 1- Ronald Williams
District No. 2- Rusty DePratter
District No. 3- Bucky Nash
District No. 4- Everett Phillips
District No. 5- Tim Murphy

BOARD OF COUNTY COMMISSIONERS

COLUMBIA COUNTY

MEMORANDUM

DATE: September 13, 2018
TO: Ben Scott
FR: Glenn Hunter *GH*
RE: Amended Resolution

I am asking for approval of Resolution Number 2018R-42 which has been amended and restated per the request of DEO. The Resolution originally read "Whereas, Project 18-10 will employ citizens of Columbia County ...". It is being amended to read "Whereas, Project 18-10 will create 35 jobs in Columbia County ..."

GH

BOARD MEETS FIRST THURSDAY AT 5,30P.M
AND THIRD THURSDAY AT 5,30P.M

P.O. BOX 1529

LAKE CITY, FLORIDA 32056-1529

PHONE 386.755.4100

**QUALIFIED TARGET INDUSTRY TAX REFUND IN A RURAL AREA
REQUESTING WAIVER OF LOCAL FINANCIAL SUPPORT**

RESOLUTION NUMBER 2018R-42

A RESOLUTION BY THE GOVERNING BOARD OF COLUMBIA COUNTY, FLORIDA, TO RESTATE AND AMEND PRIOR RESOLUTION NUMBER 2018R-28 RECOMMENDING PROJECT 18-10, BE APPROVED AS A QUALIFIED TARGET INDUSTRY BUSINESS PURSUANT TO S.288.106, FLORIDA STATUTES; AFFIRMING THE SITE OF THIS PROJECT IS WITHIN A DEFINED RURAL AREA; REQUESTING A WAIVER OF LOCAL FINANCIAL SUPPORT; PROVIDING FOR AN EFFECTIVE DATE.

BE IT RESOLVED BY THE GOVERNING BOARD OF COLUMBIA COUNTY, FLORIDA, as follows :

WHEREAS, the business under consideration is a manufacturing business, specifically, **PROJECT 18-10;** and

WHEREAS, PROJECT 18-10 will create 35 jobs in Columbia County and will do business in this County ; and

WHEREAS, PROJECT 18-10 plans to construct and commence its operations through capital improvements; and

WHEREAS PROJECT 18-10 has been identified as a Target Industry Business; and

WHEREAS, PROJECT 18-10 intends to locate its business in Columbia County ; and

WHEREAS, this location within COLUMBIA COUNTY meets the definition of a Rural Community pursuant to s.288 .106(2)(p), Florida Statutes; and

WHEREAS, due to this location **PROJECT 18-10,** as the Applicant, is eligible for the local financial support exemption option of the Qualified Target Industry Tax Refund Program authorized for a Rural Community under s.288 .106(2)(k), Florida Statutes, and desires to exercise that option; and

NOW, THEREFORE, BE IT RESOLVED BY THE GOVERNING BOARD OF COLUMBIA COUNTY, FLORIDA, that the Board hereby recommends **PROJECT 18-10** be approved as a Qualified Target Industry Business pursuant to s.288.106 , Florida Statutes.

BE IT FURTHER RESOLVED, that the Governing Board of COLUMBIA COUNTY has determined the basis of this project's average private sector wage commitment calculation shall be in excess of 100% of the county average annual wage of \$32,974 .

BE IT FURTHER RESOLVED that **COLUMBIA COUNTY, FLORIDA** requests that a waiver of the local financial support be granted as authorized under the Qualified Target Industry Refund Program, pursuant to s.288 .106(2)(k), Florida Statutes.

This resolution shall take effect immediately upon its adoption.

DULY ADOPTED BY THE GOVERNING BOARD OF COLUMBIA COUNTY FLORIDA this _____day of September, 2018.

COLUMBIA COUNTY
BOARD OF COUNTY
COMMISSIONERS COLUMBIA
COUNTY, FLORIDA

Tim Murphy, Chairman

Approved as to form:

Joel F. Foreman, Attorney

ATTEST:

P. DeWitt Cason, Clerk



COLUMBIA COUNTY BOARD OF COUNTY COMMISSIONERS
AGENDA ITEM REQUEST FORM

The Board of County Commissioners meets the 1st and 3rd Thursday of each month at 5:30 p.m. in the Columbia County School Board Administrative Complex Auditorium, 372 West Duval Street, Lake City, Florida 32055. All agenda items are due in the Board's office one week prior to the meeting date.

Today's Date: September 7, 2018 Meeting Date: September 20, 2018

Name: Katrina Evans Department: Library

Division Manager's Signature: [Handwritten Signature]

1. Nature and purpose of agenda item:

Requesting BCC approval to do the Food for Fines library project November 13-19, 2018.

Attach any correspondence information, documents and forms for action i.e., contract agreements, quotes, memorandums, etc.

2. Fiscal impact on current budget.

Is this a budgeted item? [X] N/A [] Yes Account No. [] No Please list the proposed budget amendment to fund this request

Budget Amendment Number: Fund:

FROM: TO: AMOUNT:

For Use of County Manager Only:

[X] Consent Item [] Discussion Item

Columbia County Public Library
308 NW Columbia Avenue
Lake City, FL 32055
386-758-1018 * 386-758-2135 Fax

Katrina P. Evans, Library Director

MEMORANDUM

DATE: September 7, 2018

TO: David Kraus, Assistant County Manager

FR: Katrina Evans, Library Director

RE: Food for Fines Project

Since 2008, the Library has had an annual *Food for Fines* project that has benefitted the Christian Service Center and the Fort White United Methodist Church food pantry during the month of November. For every single, non-expired, non-perishable food item brought into the Library during the week of the project, a library patron had \$1.00 deducted from her/his fines and fees. I am requesting approval to do the *Food for Fines* project again this year from November 13-19, 2018.

Please let me know if you need further explanation or information. Thank you for your consideration.



COLUMBIA COUNTY BOARD OF COUNTY COMMISSIONERS AGENDA ITEM REQUEST FORM

The Board of County Commissioners meets the 1st and 3rd Thursday of each month at 5:30 p.m. in the Columbia County School Board Administrative Complex Auditorium, 372 West Duval Street, Lake City, Florida 32055. All agenda items are due in the Board's office one week prior to the meeting date.

Today's Date: September 7, 2018 Meeting Date: September 20, 2018

Name: Katrina Evans Department: Library

Division Manager's Signature: 

1. Nature and purpose of agenda item:

Requesting BCC approval for the Library to close on Veterans Day, Sunday, November 11, 2018, in addition to the observed County holiday for Veterans Day on Monday, November 12, 2018.

Attach any correspondence information, documents and forms for action i.e., contract agreements, quotes, memorandums, etc.

2. Fiscal impact on current budget.

Is this a budgeted item? N/A
 Yes Account No. _____
 No Please list the proposed budget amendment to fund this request

Budget Amendment Number: _____ Fund: _____

FROM: _____ TO: _____ AMOUNT: _____

For Use of County Manager Only:

Consent Item Discussion Item

Columbia County Public Library
308 NW Columbia Avenue
Lake City, FL 32055
386-758-1018 * 386-758-2135 Fax

Katrina P. Evans, Library Director

MEMORANDUM

DATE: September 4, 2018

TO: David Kraus, Assistant County Manager

FR: Katrina Evans, Library Director

RE: Library Closing for Veterans Day

Because Veterans Day (November 11) falls on a Sunday, the County holiday will be observed on Monday, November 12. However, the Main Library is normally open to the public on Sundays, the day of the actual holiday. I would like to request approval by the Board of County Commissioners for the Library close on Sunday, November 11, 2018, in addition to the observed County holiday on November 12, in observation of Veterans Day. Staff who would normally be scheduled to work on Sunday, November 11 would have the opportunity to work those hours at another time during the week or to use annual leave. I would provide sufficient public notice in advance of the holiday closings. Please let me know if you need any further information from me. Thank you for your consideration.



COLUMBIA COUNTY BOARD OF COUNTY COMMISSIONERS
AGENDA ITEM REQUEST FORM

The Board of County Commissioners meets the 1st and 3rd Thursday of each month at 5:30 p.m. in the Columbia County School Board Administrative Complex Auditorium, 372 West Duval Street, Lake City, Florida 32055. All agenda items are due in the Board's office one week prior to the meeting date.

Today's Date: September 7, 2018 Meeting Date: September 20, 2018

Name: Katrina Evans Department: Library

Division Manager's Signature: [Handwritten Signature]

1. Nature and purpose of agenda item:

Requesting BCC approval of LSTA Innovation Grant application, due October 4, 2018

Attach any correspondence information, documents and forms for action i.e., contract agreements, quotes, memorandums, etc.

2. Fiscal impact on current budget.

Is this a budgeted item? [X] N/A [] Yes Account No. [] No Please list the proposed budget amendment to fund this request

Budget Amendment Number: Fund:

FROM: TO: AMOUNT:

For Use of County Manager Only:

[X] Consent Item [] Discussion Item

Columbia County Public Library
308 NW Columbia Avenue
Lake City, FL 32055
386-758-1018 * 386-758-2135 Fax

Katrina P. Evans, Library Director

MEMORANDUM

DATE: September 7, 2018

TO: David Kraus, Assistant County Manager

FR: Katrina Evans, Library Director

RE: LSTA Innovation Grant Application

The attached document serves as an application for grant funds of \$3882.08 from Florida's Division of Library and Information Services through the LSTA Innovation Grant program. The Division is currently accepting requests from Florida libraries for grants of up to \$4,000 for the purchase of "tangible items that will support innovation." If funded, this grant would allow the library to purchase sewing machines and supplies so that the Library can offer free sewing classes, taught by knowledgeable library staff, to the public. Grant funds would also be used to update and expand the Library's existing collection of books and other materials on the topic of sewing. All requests must be received by October 4, 2018, in order to be considered. If you have any questions, please let me know. Thank you.

Supporting Public Library Innovation Grant Application
Deadline: October 4, 2018 at 6:00 p.m. Eastern

- ❖ Library Name Columbia County Public Library
- ❖ Library Address 308 NW Columbia Ave Lake City, FL 32055
- ❖ Library Director Name Katrina P. Evans
- ❖ Project Manager Name Zulima Martinez and Mary Williams

❖ Need

Describe the item(s) the library will purchase.

12 portable sewing machines and carrying cases

Sewing supplies and notions (scissors, thread, needles, pins, bobbins, seam rippers, iron and ironing board, pinking shears, tape measures, pin cushions, fabric, etc.)

Storage containers for sewing supplies and notions

Updated library materials on sewing for the library's circulating collections

❖ Intent

How will the item(s) be used to support innovation in the library?

The sewing machines and other supplies will be used to provide free basic sewing and quilting classes for the public. Classes will be taught primarily by a member of the library staff who is a talented seamstress. Those attending the sewing and quilting programs will have the opportunity to learn new skills that can save them time and money and to develop new interests and hobbies that can enrich their lives. Class attendees will be able to use their newly acquired skills in ways that are only limited by their imaginations.

In addition to sewing classes, in each of our three Library locations, at least one sewing machine will also be available for in-library use by the public who will be able to schedule time to use it to make simple clothing repairs or work on an independent sewing project. Many people have sewing skills but lack the financial resources and/or the space needed to own their own sewing machine. This grant would enable the Library to provide that resource for members of our community.

❖ Location

Where will the item(s) be used?

The public sewing and quilting classes are planned to take place primarily at the West Branch of the Columbia County Public Library. Because the sewing machines are easily portable, they can also be used to offer classes at the Main Library and the Fort White Branch as well, or even at an outreach location. There will also be at least one sewing machine at each of the three library locations to be used by patrons in the library for independent sewing projects.

❖ Budget – maximum request is \$4,000 per library system.

What will the item(s) cost?

\$1672.20: 12 sewing machines (Singer 4423 Heavy Duty Sewing Machine or similar model) @ \$139.35 each
\$359.88: 12 carrying cases (Singer Universal Fit Sewing Machine Carrying Case, Model 621.01 or similar) @ \$29.99 each
\$750.00: Sewing supplies and notions (scissors, thread, needles, pins, bobbins, seam rippers, iron and ironing board, pinking shears, tape measures, pin cushions, fabric, etc.)
\$100.00: Storage containers for sewing supplies and notions
\$1000.00: Updated library materials on sewing for the library's circulating collections
Total budget: \$3882.08

❖ The following Certifications have been signed and submitted with the application:

Yes



Debarment Form

All applicants must complete this form to certify that they will not do business with someone who has been barred from doing business with the federal government.

Yes



Federal Funding Accountability and Transparency Act (FFATA)

All applicants must complete this form to provide information that may be reported to the federal transparency reporting site.

Yes



Internet Safety Certification Form.

All applicants must complete this form.

If your project is purchasing anything that will, or can, access the Internet, your organization must filter all computers, including staff computers, in accordance with 20 U.S. Code § 9134(f).

Yes



N/A



Lobbying Activities Form

Complete this form if your organization lobbies Congress for the passage of any federal act or law, or if your organization pays for a person to lobby Congress.



I hereby certify that I am authorized to submit this application on behalf of (enter full name of library)

Columbia County Public Library

and that all information indicated is true and accurate. I acknowledge that my electronic signature below shall have the same legal effect as my written signature. I am aware that making a false statement or representation to the Department of State constitutes a third degree felony as provided for in s. 817.155, F.S., punishable as provided for by ss. 775.082, 775.083, and 775.084.

Signature (Enter first and last name) Katrina P. Evans

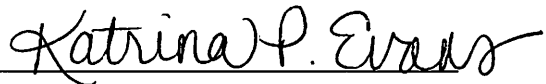

Applications will be accepted via email at david.beach@dos.myflorida.com or via fax at 850.245.6643.

INSTRUCTIONS FOR CERTIFICATION

1. By signing and submitting this proposal, the prospective lower tier participant is providing the certification set out below.
2. The certification in this clause is a material representation of fact upon which reliance was placed when this transaction was entered into. If it is later determined that the prospective lower tier participant knowingly rendered an erroneous certification, in addition to other remedies available to the federal government, the department or agency with which this transaction originated may pursue available remedies, including suspension and/or debarment.
3. The prospective lower tier participant shall provide immediate written notice to the person to which this proposal is submitted if at any time the prospective lower tier participant learns that its certification was erroneous when submitted or has become erroneous by reason of changed circumstances.
4. The terms “covered transaction,” “debarred,” “suspended,” “ineligible,” “lower tier covered transaction,” “participant,” “person,” “primary covered transaction,” “principal,” “proposal,” and “voluntarily excluded,” as used in this clause, have the meanings set out in the Definitions and Coverage sections of rules implementing Executive Order 12549. You may contact the person to which this proposal is submitted for assistance in obtaining a copy of those regulations.
5. The prospective lower tier participant agrees by submitting this proposal that, should the proposed covered transaction be entered into, it shall not knowingly enter into any lower tier covered transaction with a person who is debarred, suspended, declared ineligible, or voluntarily excluded from participation in this covered transaction, unless authorized by the department or agency with which this transaction originated.
6. The prospective lower tier participant further agrees by submitting this proposal that it will include the clause titled “Certification Regarding Debarment, Suspension, Ineligibility, and Voluntary Exclusion-Lower Tier Covered Transactions,” without modification, in all lower tier covered transactions and in all solicitations for lower tier covered transactions.
7. A participant in a covered transaction may rely upon a certification of a prospective participant in a lower tier covered transaction that it is not debarred, suspended, ineligible, or voluntarily excluded from the covered transaction, unless it knows that the certification is erroneous. A participant may decide the method and frequency by which it determines the eligibility of its principals. Each participant may, but is not required to, check the Nonprocurement List (Telephone Number).
8. Nothing contained in the foregoing shall be construed to require establishment of a system of records in order to render in good faith the certification required by this clause. The knowledge and information of a participant is not required to exceed that which is normally possessed by a prudent person in the ordinary course of business dealings.
9. Except for transactions authorized under paragraph 5 of these instructions, if a participant in a covered transaction knowingly enters into a lower tier covered transaction with a person who is suspended, debarred, ineligible, or voluntarily excluded from participation in this transaction, in addition to other remedies available to the federal government, the department or agency with which this transaction originated may pursue available remedies, including suspension and/or debarment.

**CERTIFICATION REGARDING
DEBARMENT, SUSPENSION, INELIGIBILITY AND VOLUNTARY EXCLUSION
LOWER TIER COVERED TRANSACTIONS**

This certification is required by the regulations implementing Executive Order 12549, Debarment and Suspension, 45 CFR 1183.35, Participants' responsibilities. The regulations were published as Part VII of the May 26, 1988 Federal Register (pages 19160-19211). Copies of the regulations may be obtained by contacting the person to which this proposal is submitted.

(BEFORE COMPLETING CERTIFICATION, READ INSTRUCTIONS ON REVERSE)

(1) The prospective lower tier participant certifies, by submission of this proposal, that neither it nor its principals are presently debarred, suspended, proposed for debarment, declared ineligible, or voluntarily excluded from participation in this transaction by any federal department or agency.

(2) Where the prospective lower tier participant is unable to certify to any of the statements in this certification, such prospective participant shall attach an explanation to this proposal.

Danielle Beard, Finance Director
Name and Title of Authorized Representative

Danielle Beard
Signature

9-7-18
Date

Federal Funding Accountability and Transparency Act (FFATA) Reporting

Subgrantees must complete the Federal Funding Accountability and Transparency Act Reporting form. The FFATA Act requires that information on federal awards and executive compensation be made available to the public through a single searchable website, www.USASpending.gov.

Applicability and What to Report

- A. If, in the previous fiscal year, the subgrantee's gross income from all sources was under \$300,000, it is exempt from the requirements to report:
1. Subawards, and
 2. The total compensation of the five most highly compensated executives of the subgrantee.
- B. If the subgrantee is not exempt as provided in paragraph A., the subgrantee shall report the names and total compensation of each of its five most highly compensated executives, **if** -
1. In the subgrantee's preceding fiscal year, the subgrantee received:
 - a) 80 percent or more of its annual gross revenues from Federal procurement contracts (and subcontracts) and Federal financial assistance subject to the Transparency Act, as defined at 2 CFR 170.320 (and subawards); **and**
 - b) \$25,000,000 or more in annual gross revenues from Federal procurement contracts (and subcontracts), and Federal financial assistance subject to the Transparency Act (and subgrantees); and
 2. The public does not have access to information about the compensation of the executives through periodic reports filed under section 13(a) or 15(d) of the Securities Exchange Act of 1934 (15 U.S.C. 78m(a), 78o(d)) or section 6104 of the Internal Revenue Code of 1986. (To determine if the public has access to the compensation information, see the U.S. Security and Exchange Commission total compensation filings at www.sec.gov/answers/execomp.htm.)

Definitions

Total compensation means the cash and noncash dollar value earned by the executive during the subgrantee's preceding fiscal year and includes the following (for more information see 17 CFR 229.402(c)(2)):

- i. Salary and bonus.
- ii. Awards of stock, stock options, and stock appreciation rights. Use the dollar amount recognized for financial statement reporting purposes with respect to the fiscal year in accordance with the Statement of Financial Accounting Standards No. 123 (Revised 2004) (FAS 123R), Shared Based Payments.
- iii. Earnings for services under non-equity incentive plans. This does not include group life, health, hospitalization or medical reimbursement plans that do not discriminate in favor of executives, and are available generally to all salaried employees.
- iv. Change in pension value. This is the change in present value of defined benefit and actuarial pension plans.
- v. Above-market earnings on deferred compensation which is not tax-qualified.
- vi. Other compensation, if the aggregate value of all such other compensation (e.g., severance, termination payments, value of life insurance paid on behalf of the employee, perquisites or property) for the executive exceeds \$10,000.

Executive means officers, managing partners, or any other employees in management positions.

Data Universal Numbering System (DUNS) number means the nine-digit number established and assigned by Dun and Bradstreet, Inc. (D&B) to uniquely identify business entities. A DUNS number may be obtained from D&B by telephone (866.705.5711) or the Internet (<http://fedgov.dnb.com/webform>).

Federal Funding Accountability and Transparency Act (FFATA) Reporting

Name of Organization: Columbia County Public Library

DUNS Number: 119723273

Check one of the following:

The organization does not meet the applicability requirements to report the total compensation of the top five subgrantee executives and will not report total compensation for the preceding completed fiscal year.

The organization meets the applicability requirements to report the total compensation of top five subgrantee executives for the preceding completed fiscal year.

	Name	Total Compensation
1.	_____	_____
2.	_____	_____
3.	_____	_____
4.	_____	_____
5.	_____	_____

Danielle Beard

Signature (Official who can verify status of information provided)

Danielle Beard, Finance Director

Print Name and Title

9-7-18

Date

**INTERNET SAFETY CERTIFICATION FOR APPLICANT
PUBLIC LIBRARIES
PUBLIC ELEMENTARY AND SECONDARY SCHOOL LIBRARIES, and
CONSORTIA WITH PUBLIC AND/OR PUBLIC SCHOOL LIBRARIES**

As the duly authorized representative of the applicant library, I hereby certify that the library is (*check only one of the following boxes*)

A. CIPA Compliant
*(The applicant library has complied with the requirements of
Section 9134(f)(1) of the Library Services and Technology Act.)*

OR

B. The CIPA requirements do not apply because no funds made available under the LSTA program are being used to purchase computers to access the Internet, or to pay for direct costs associated with accessing the Internet.

Katrina P. Evans
Signature of Authorized Representative

Katrina P. Evans
Printed Name of Authorized Representative

Library Director
Title of Authorized Representative

9/7/2018
Date

Columbia County Public Library
Name of Applicant Library/Program



COLUMBIA COUNTY BOARD OF COUNTY COMMISSIONERS
AGENDA ITEM REQUEST FORM

The Board of County Commissioners meets the 1st and 3rd Thursday of each month at 5:30 p.m. in the Columbia County School Board Administrative Complex Auditorium, 372 West Duval Street, Lake City, Florida 32055. All agenda items are due in the Board's office one week prior to the meeting date.

Today's Date: September 11, 2018 Meeting Date: September 20, 2018

Name: Clint Pittman Department: Parks And Landscaping

Division Manager's Signature: [Handwritten Signature]

1. Nature and purpose of agenda item:

BA 18-70--Funds contributed to purchase additional ball field clay to recondition the infields. \$4,000.

Attach any correspondence information, documents and forms for action i.e., contract agreements, quotes, memorandums, etc.

2. Fiscal impact on current budget.

Is this a budgeted item? [] N/A [] Yes Account No. [X] No Please list the proposed budget amendment to fund this request

Budget Amendment Number: BA 18-70 Fund: 302-GENERAL CAPITAL PROJECTS

Table with 3 columns: FROM, TO, AMOUNT. FROM: 302-0000-366.20-00 CONTRIBUTIONS & DONATIONS / CONTRIBUTIONS TO: 302-5711-575.30-46 OPERATING EXPENDITURES / REPAIRS & MAINTENANCE AMOUNT: \$4,000.00

For Use of County Manager Only:

[X] Consent Item [] Discussion Item



**COLUMBIA COUNTY BOARD OF COUNTY COMMISSIONERS
AGENDA ITEM REQUEST FORM**

The Board of County Commissioners meets the 1st and 3rd Thursday of each month at 5:30 p.m. in the Columbia County School Board Administrative Complex Auditorium, 372 West Duval Street, Lake City, Florida 32055. All agenda items are due in the Board's office one week prior to the meeting date.

Today's Date: September 12, 2018 Meeting Date: September 20, 2018

Name: Kevin Kirby Department: Public Works

Division Manager's Signature: 

1. Nature and purpose of agenda item:

Permission to enter private property

Attach any correspondence information, documents and forms for action i.e., contract agreements, quotes, memorandums, etc.

2. Fiscal impact on current budget.

Is this a budgeted item? N/A
 Yes Account No. _____
 No Please list the proposed budget amendment to fund this request

Budget Amendment Number: _____ Fund: _____

FROM: _____ TO: _____ AMOUNT: _____

For Use of County Manager Only:

Consent Item Discussion Item



BOARD OF COUNTY COMMISSIONERS • COLUMBIA COUNTY

Memo

Date: September 12, 2018
To: Ben Scott, County Manager
From: Kevin Kirby, Assistant County Manager 
RE: Entering Private Property

I am requesting permission to enter private property after the fact known as parcel #09068-000.

A tree in the county right-of-way was in jeopardy of falling and damaging the property owner's fence.

The attached Hold Harmless Agreement was obtained.

Thank you.



PHOTO: JIMMY PEA

PHOTO: JIMMY PEA
PHOTO: JIMMY PEA
PHOTO: JIMMY PEA

GENERAL RELEASE AND HOLD HARMLESS AGREEMENT

The undersigned private property owner, Everette "Arky" Rogers, and COLUMBIA COUNTY, FLORIDA, by and through its representative Rick Coulombe, "County", hereby agree as follows:

WHEREAS, Owner agrees for County to enter upon Owner's property identified as parcel #09068-000 for the purpose of tree removal.

WHERE, Owner authorizes County to enter upon Owner's private property and release County from liability as a result thereof, and

WHEREAS, County agrees to hold Owner harmless from liability as a result of County's actions upon Owner's property.

NOW THEREFORE, in consideration of the mutual covenants set forth herein the parties agree as follows:

1. Owner hereby authorizes County and its representatives to enter upon Owner's property for the purpose of tree removal.
2. Owner hereby releases County together with its agents, representatives and employees from any and all actions cause of actions or liability, including for trespass damages or other claims or demands whatsoever, in law or in equity as a result of County's actions upon Owner's property, so long as the same is not done in any grossly negligent manner.
3. County hereby agrees to hold Owner harmless from any liability as a result of County's actions upon Owner's property or the actions of any third parties, which may enter on Owner's property upon County's direction or authorization.

Dated this 6TH day of SEPTEMBER, 2018.

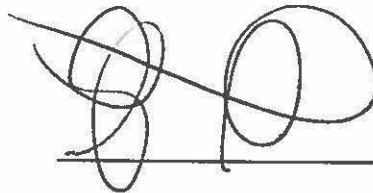

PROPERTY OWNER SIGNATURE

COLUMBIA COUNTY REPRESENTATIVE
Rick Coulombe, Tree Crew Foreman



COLUMBIA COUNTY BOARD OF COUNTY COMMISSIONERS AGENDA ITEM REQUEST FORM

The Board of County Commissioners meets the 1st and 3rd Thursday of each month at 5:30 p.m. in the Columbia County School Board Administrative Complex Auditorium, 372 West Duval Street, Lake City, Florida 32055. All agenda items are due in the Board's office one week prior to the meeting date.

Today's Date: September 6, 2018 Meeting Date: September 20, 2018

Name: Kevin Kirby Department: Public Works

Division Manager's Signature: 

1. Nature and purpose of agenda item:

Approve utility permit for Guerdon St.

Attach any correspondence information, documents and forms for action i.e., contract agreements, quotes, memorandums, etc.

2. Fiscal impact on current budget.

Is this a budgeted item? N/A
 Yes Account No. _____
 No Please list the proposed budget amendment to fund this request

Budget Amendment Number: _____ Fund: _____

FROM: _____ TO: _____ AMOUNT: _____

For Use of County Manager Only:

Consent Item Discussion Item

AT&T JOB #:83E61216N

**COLUMBIA COUNTY BOARD OF COUNTY COMMISSIONERS
UTILITY PERMIT**

Date: 9-5-18 Permit No. _____ County Road 528 NW GUERDON ST Section No. _____

Permittee At&t Authorized Agent Rebecka Bonts Email: RBonts@truenetcommunications.com
Address 7666 Blanding Blvd. Jacksonville, Fl. 32244 Telephone Number 904-777-9052 ext.258

Requesting permission from the Columbia County Board of County Commissioners, hereinafter called the County, to contract, operate and maintain: **Propose placing 543' of aerial cable lashed to existing 10M strand and 80' of Buried fiber cable trenched @ 30" min depth and pulled thru proposed 2" conduit bored @ 48" min depth.**

Submitted for the Utility Owner by: Rebecka Bonts AT&T Authorized Agent
Typed Name & Title Signature Date

1. Permittee declares that prior to filing this application it has determined the location of all existing utilities, both aerial and underground and the accurate locations are shown on the plans attached hereto and made a part of this application. Proposed work is within the corporate limits of Municipality: YES () NO (x). If YES: LAKECITY () FORT WHITE (). A letter of notification was mailed on 9-6-18 to the following utility owners: FP&L

2. The Columbia County Public Works Director shall be notified twenty-four (24) hours prior to starting work and again immediately upon completion of work. The Public Works Director is Kevin Kirby, located at P.O. Box 969, Lake City, FL 32056 Telephone Number (386) 752-5955. The PERMITTEE's employee responsible for Maintenance of Traffic is Mike Brown, Telephone Number (352) 336-5508 (This name may be provided at the time of the 24 hour notice to starting work).

3. This PERMITTEE shall commence actual construction in good faith within _____ days after issuance of permit, and shall be completed within _____ days after permitted work has begun. If the beginning date is more than 60 days from date of permit approval, then PERMITTEE must review the permit with the Columbia County Public Works Director to make sure no changes have occurred in the transportation facility that would affect the permitted construction.

4. The construction and maintenance of such utility shall not interfere with the property and rights of a prior PERMITTEE.

5. It is expressly stipulated that this permit is a license for permissive use only and that the placing of utilities upon public property pursuant to this permit shall not operate to create or vest any property right in said holder.

6. Pursuant to Section 337.403(1), Florida Statutes, whenever necessary for the construction, repair, improvement, maintenance, safe and efficient operation, alteration or relocation of all, or any portion of said transportation facility as determined by the Columbia County Public Works Director and/or County Engineer, any or all utilities and appurtenances authorized hereunder, shall be immediately removed from said transportation facility or reset or relocated thereon as required by the Columbia County Public Works Director and/or County Engineer and at the expense of the PERMITTEE.

Utilities Permit

Revised: 08-28-00

7. In case of non-compliance with the County's requirements in effect as of the approval date of this permit, this permit is void and the facility will have to be brought into compliance or removed from the right of way at no cost to the County.

8. It is understood and agreed that the rights and privileged herein set out are granted only to the extent of the County's right, title and interest in the land to be entered upon and used by the PERMITTEE, and the PERMITTEE will, at all times, and to the extent permitted by law, assume all risk of and indemnify, defend, and save harmless the Columbia County Board of County Commissioners from any and all loss, damage, cost or expense arising in any manner on account of the exercise or attempted exercise by said PERMITTEE of the aforesaid right and privileges.

9. During construction, all safety regulations of the County shall be observed and the PERMITTEE must take measures, including placing and the display of safety devices that may be necessary in order to safely conduct the public through the project area in accordance with the Federal Manual on the Uniform Traffic Control Devices, as amended for highways.

10. Should the PERMITTEE be desirous of keeping its utilities in place and out of service, the PERMITTEE, by execution of this permit acknowledges its present and continuing ownership of its utilities located between _____ and _____ within the County's right of way as set forth above. PERMITTEE, at its sole expense, shall promptly remove said out of service utilities whenever Columbia County Public Works Director and/or County Engineer determines said removal is in the public interest.

11. Special instruction: Minimum cover of thirty inches (30") will be required at all locations. Columbia County will not be financially responsible for any damage to facilities with less than thirty inch (30") cover. Cables shall not be located within driveway ditches.

12. Additional Stipulations: _____

It is understood and agreed that commencement by the PERMITTEE is acknowledgment and acceptance of the binding nature of these special instructions.

Submitted By: Rebecka Bonts

Signature

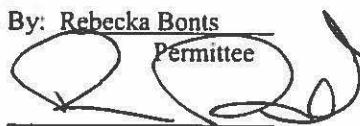
Permittee

Place Corporate Seal

Attest

Title: AT&T Authorized Agent

Utilities Permit
Revised: 5/4/99

Recommended for Approval:

Signature: _____

Title : _____

Date : _____

Approved by Columbia County Board of County Commissioners:

YES () NO ()

Date Approved: _____

Chairman's Signature: _____



PERMIT TO PLACE FIBER-OPTIC CABLE IN THE RIGHT OF WAY OF
COLUMBIA COUNTY
 ALONG NW GUERDON ST

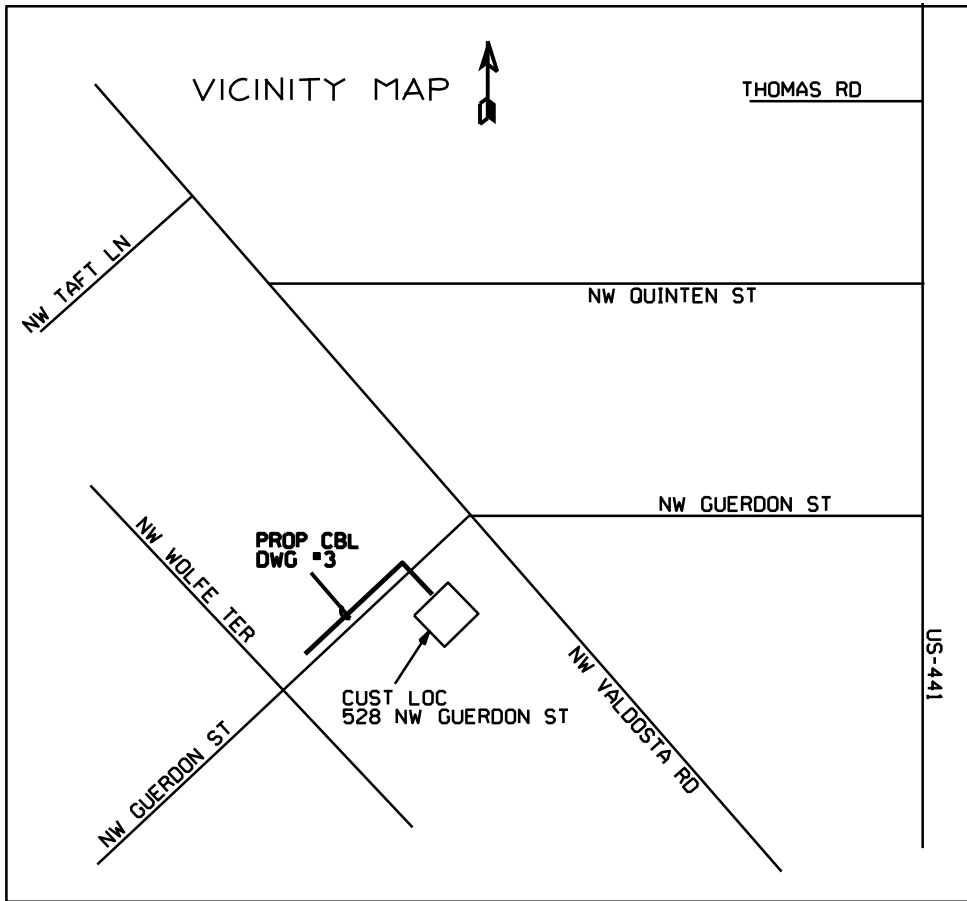

CAUTION
 Volts to Ground
14.4 KV
 JOINT USE POWER COMPANY
 FPL ELECT AERIAL
 MAINTAIN PROPER POWER CLEARANCE

CALL BEFORE YOU DIG

DIAL 811
 TWO FULL BUS. DAYS BEFORE YOU DIG
IT IS THE CONTRACTOR'S RESPONSIBILITY TO CONTACT UTILITY COMPANIES PRIOR TO ANY CONSTRUCTION AS THE LOCATION OF UTILITIES SHOWN ON THIS PLAN ARE APPROXIMATE AND POSSIBLY INCOMPLETE. THEREFORE CERTIFICATION TO THE LOCATION OF ALL UNDERGROUND UTILITIES IS WITHHELD.

MAINTENANCE OF TRAFFIC PLANS INCLUDED WITH DRAWING CONSTRUCTION NOTES:

- 1) SIDEWALK TO BE REMOVED AND REPLACED AS NEEDED FOR BORE AND CORE.
- 2) RESTORATION PER COUNTY STANDARDS
- 3) UTILITY LOCATIONS (TELEPHONE AND NON-TELEPHONE) ARE TO BEST INFORMATION AND APPROXIMATE ONLY. SEE OWNERS & CONTRACTORS FOR VERIFICATION OF EXACT LOCATION PRIOR TO WORK OPERATIONS.
- 4) NOTIFY COUNTY INSPECTOR 2 FULL BUSINESS DAYS BEFORE BEGINNING WORK
- 5) RESTORE ALL EXCAVATIONS TO ORIGINAL OR BETTER.
- 6) ALL TRENCHES WILL BE OPENED AND MAINTAINED FOLLOWING CURRENT AUM AND COUNTY STANDARD PLANS.

IT IS RECOMMENDED THAT AND DIGGING, SOFT, SOFT DIGGING, VACUUM EXCAVATION ETC. BE USED IN THE 24" TOLERANCE ZONE TO EXPOSE UNDERGROUND FACILITIES.
- 7) CALL SUNSHINE STATE ONE CALL FLORIDA, INC AT 811 TO REQUEST A LOCATE OF ANY UNDERGROUND FACILITIES AT YOUR EXCAVATION SITE.
- 8) CONTRACTOR TO PROVIDE A NOTICE OF COMMENCEMENT TO THE PERMIT AGENCY ENGINEERING DEPARTMENT 48 HOURS PRIOR TO BEGINNING CONSTRUCTION.
- 9) MAINTAIN 18" VERTICAL CLEARANCE, 6' HORIZONTAL CLEARANCE BETWEEN EXISTING UTILITIES AND 36" COVER.

SYMBOL LEGEND		
Proposed	Existing	Description
		AERIAL CABLE
		BURIED CABLE
		BUR JOINT-TRENCH
		BST POLE
		POWER POLE
		ANCHOR & GUY
		PUSH BRACE
		ENCLOSURE
		MANHOLE
		PIPE/CONDUIT
		CABLE MARKER
		AERIAL SVC WIRE
		BURIED SVC WIRE
		JOINT-TRENCH SVC
	N/A	BORE
	N/A	CUT PAVEMENT
	N/A	SPLICING PIT
	N/A	TRENCH LENGTH/DEPTH

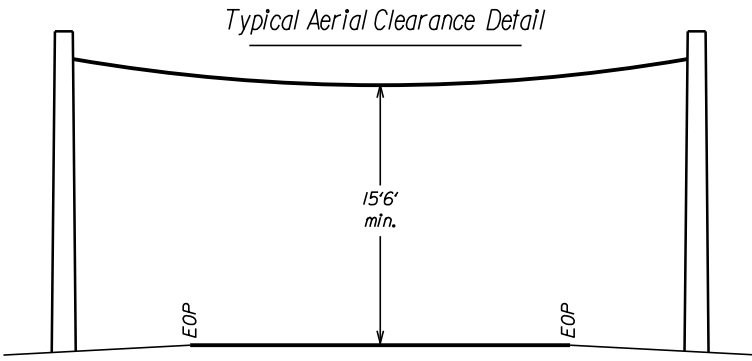
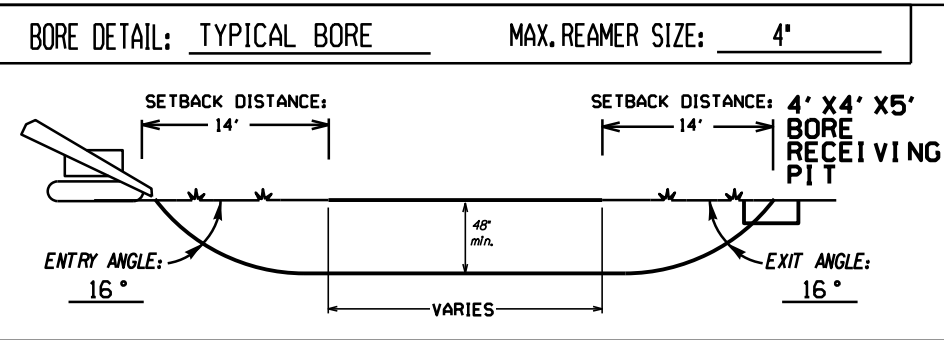

SCOPE OF WORK:
 PLACE NEW FIBER-OPTIC CABLE IN COUNTY RIGHT OF WAY REFER TO WORKPRINTS FOR ADDITIONAL DETAILS

MAINTENANCE OF TRAFFIC
 WORKERS WILL UTILIZE COUNTY M.O.T. 602

- 10) ALL WORK PERFORMED WITHIN THE COUNTY RIGHT-OF-WAY SHALL BE IN ACCORDANCE WITH THE LATEST EDITIONS OF THE COUNTY DESIGN STANDARDS, THE LATEST EDITION OF THE SPECIFICATIONS FOR ROAD AND BRIDGE CONSTRUCTION AND THE CURRENT UTILITY ACCOMMODATION MANUAL. PERMITEE SHALL NOT BEGIN A DIRECTIONAL BORE ACROSS A COUNTY ROAD UNTIL A COUNTY INSPECTOR IS PRESENT AT THE JOB SITE AND AGREES THAT PROPER PREPARATIONS HAVE BEEN MADE.
- 11) 24" MINIMUM SEPERATION FROM EXISTING STORM DRAINS. CURRENT JAM MINIMUM DEPTH REQUIREMENTS SHALL STILL BE ENFORCED.
- 12) REPLACE SIDEWALK JOINT TO JOINT PER CURRENT DESIGN STANDARD INDEX NO. 310.

NOTE TO PERMITTING AGENCY:
 THE BELOW INFORMATION IS THE ORIGINAL DRAFT PERSON WHO HAS DETAILED FIELD KNOWLEDGE OF THE PROPOSED WORK TO BE PERFORMED ON THIS PERMIT REQUEST, AND SHOULD BE THE FIRST POINT OF CONTACT WITH QUESTIONS REGARDING THESE FIELD CONDITIONS AND/OR CORRECTIONS TO THIS PERMIT REQUEST.

RYAN STANLEY
 904-806-8104

ATTSE	
PROPOSED TELEPHONE FACILITIES ON RIGHT OF WAY OF COLUMBIA COUNTY	
NW GUERDON ST	
Exchange:	386752
Designer:	Fernandez,Chris
Phone:	904-727-1554
Authorization:	83E6I2I6N
Dwg. <u> 1 </u> of <u> 3 </u>	

NOTE: OTHER CABLES OMITTED FOR CLARITY

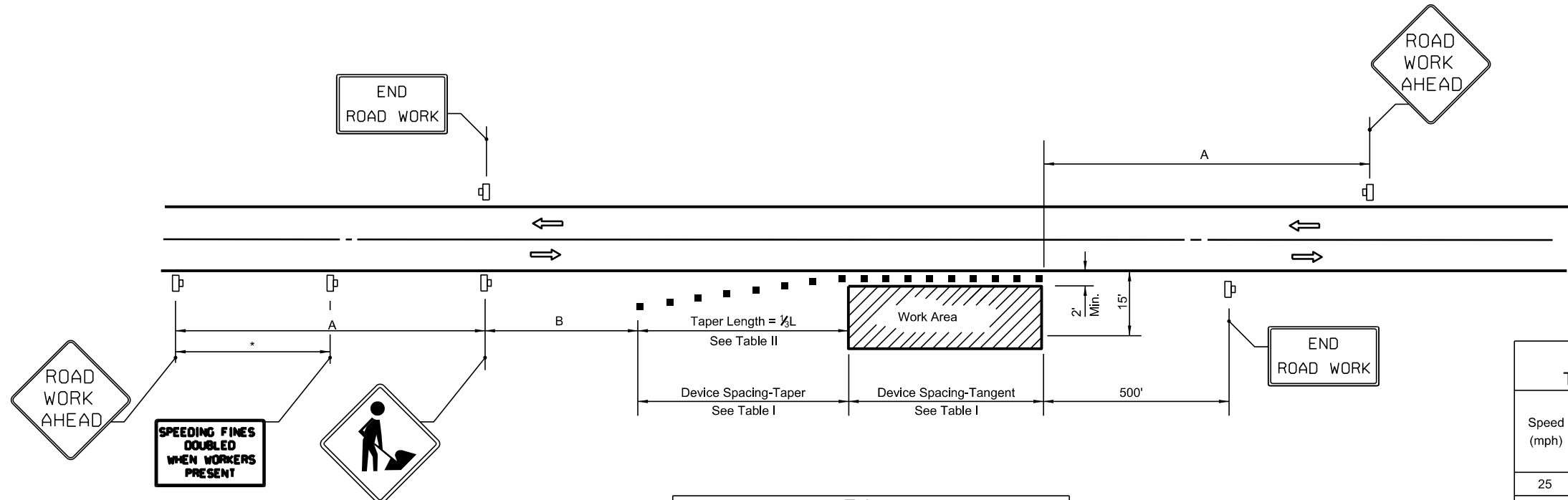

DISTANCE BETWEEN SIGNS		
Speed	Spacing (ft.)	
	A	B
40 mph or less	200	200
45 mph	350	350
50 mph or greater	500	500

*Midway between signs.

Table I Device Spacing				
Speed (mph)	Max. Distance Between Devices (ft.)			
	Cones or Tubular Markers		Type I or Type II Barricades or Vertical Panels or Drums	
	Taper	Tangent	Taper	Tangent
25	25	50	25	50
30 to 45	25	50	30	50
50 to 70	25	50	50	100

Table II Taper Length - Shoulder				
Speed (mph)	1/2 L (ft)			Notes
	8' Shldr.	10' Shldr.	12' Shldr.	
25	28	35	42	L = $\frac{WS^2}{60}$
30	40	50	60	
35	55	68	82	
40	72	90	107	L=WS
45	120	150	180	
50	133	167	200	
55	147	183	220	
60	160	200	240	
65	173	217	260	
70	187	233	280	

8' minimum shoulder width

1/2 L = Length of shoulder taper in feet

W = Width of total shoulder in feet (combined paved and unpaved width)

S = Posted speed limit (mph)

- SYMBOLS**
- Work Area
 - Channelizing Device (See Index 102-600)
 - Work Zone Sign
 - Lane Identification + Direction of Traffic

- GENERAL NOTES**
- When four or more work vehicles enter the through traffic lanes in a one hour period or less (excluding establishing and terminating the work area), the advanced FLAGGER sign shall be substituted for the WORKERS sign. For location of flaggers and FLAGGER signs, see Index 102-603.
 - SHOULDER WORK sign may be used as an alternate to the WORKER symbol sign only on the side where the shoulder work is being performed.
 - When a side road intersects the highway within the TTC zone, additional TTC devices shall be placed in accordance with other applicable TCZ Indexes.
 - For general TCZ requirements and additional information, refer to Index 102-600.

- DURATION NOTES**
- Signs and channelizing devices may be omitted if all of the following conditions are met:
 - Work operations are 60 minutes or less.
 - Vehicles in the work area have high-intensity, rotating, flashing, oscillating, or strobe lights operating.

CONDITIONS
 WHERE ANY VEHICLE, EQUIPMENT, WORKERS OR THEIR ACTIVITIES ENCROACH THE AREA CLOSER THAN 15' BUT NOT CLOSER THAN 2' TO THE EDGE OF TRAVEL WAY.

ATTSE

PROPOSED TELEPHONE FACILITIES ON RIGHT OF WAY OF COLUMBIA COUNTY

NW GUERDON ST

Exchange: 386752

Designer: Fernandez,Chris

Phone: 904-727-1554

Authorization: 83E61216N

Dwg. 2 of 3.77

10/23/2017 10:22:23 AM

LAST REVISION 11/01/17	DESCRIPTION:		FY 2018-19 STANDARD PLANS	TWO-LANE, TWO-WAY, WORK ON SHOULDER	INDEX 102-602	SHEET 1 of 1
---------------------------	--------------	--	------------------------------	-------------------------------------	------------------	-----------------



- 24 EXISTING AT&T BURIED CABLES
- 26 EXISTING AT&T AERIAL CABLES

- 543' PROPOSED AT&T AERIAL 24-FIBER OPTIC CABLE TO BE LASHED TO EXISTING 10M STRAND AND FIBER CABLE
- 75' PROPOSED BORE W/ 2" HDPE CONDUIT



Proposed	Symbol	Description
—	—	Electric
●	○	Buried
*	*	Power Pole
Y	Y	Hand & Ground
—	—	Public

Proposed	Symbol	Description
—	—	Buried Electric
—	—	Buried J-T-Enhance
▲	▲	Enclosure
□	□	Enclosure
□	□	Hand
—	—	Electric/Conduit
—	—	Electric - Ker
—	—	Buried Electric
—	—	J-T-Enhance
—	N/A	Bore
▨	N/A	Concrete
—	N/A	Spit
200'	N/A	Temporary

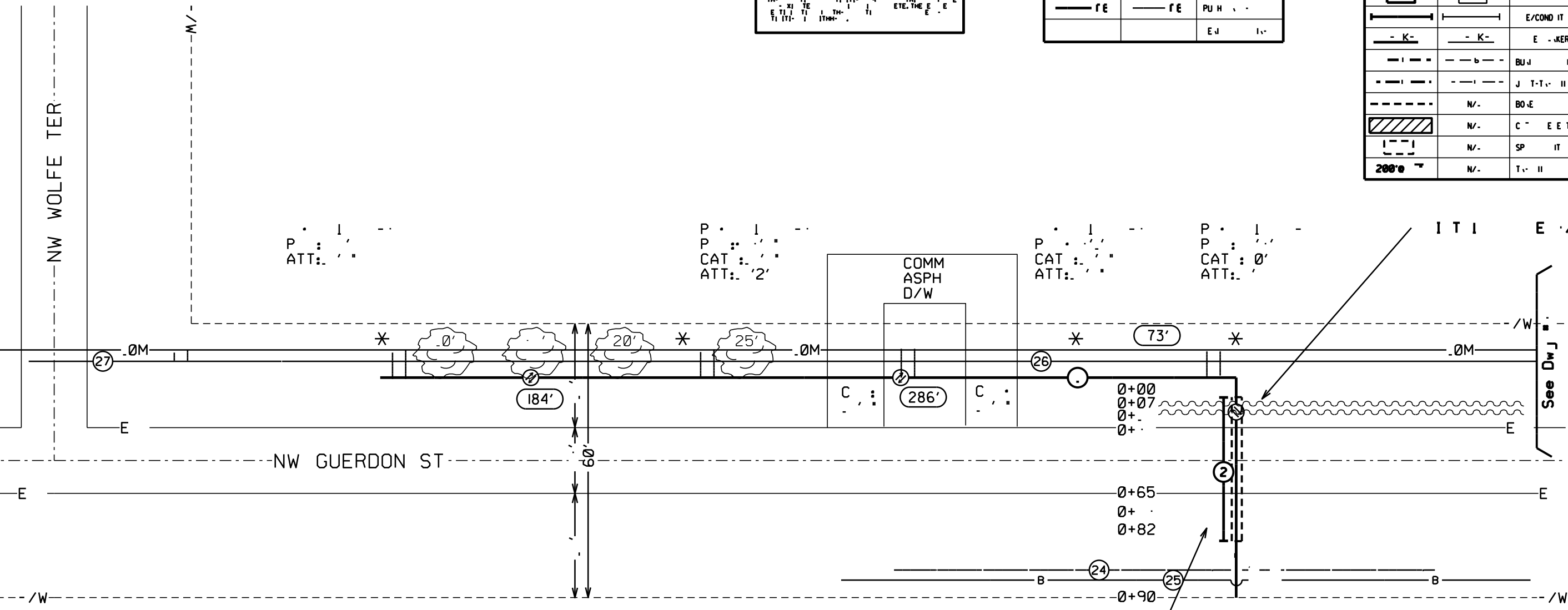

See Dwg 528

COMM ASPH D/W

528

ATTSE	
PROPOSED UTILIZATION ON RIGHT COLUMBIAN TOWNSHIP NW GUERDON ST	
Exchange :	386752
Designer :	- rnanchez,Chris
Phone :	90 -1554
Authorization :	8 - 1216N
Dwg. :	3 of 3



**COLUMBIA COUNTY BOARD OF COUNTY COMMISSIONERS
AGENDA ITEM REQUEST FORM**

The Board of County Commissioners meets the 1st and 3rd Thursday of each month at 5:30 p.m. in the Columbia County School Board Administrative Complex Auditorium, 372 West Duval Street, Lake City, Florida 32055. All agenda items are due in the Board's office one week prior to the meeting date.

Today's Date: September 13, 2018 Meeting Date: September 20, 2018

Name: Kevin Kirby Department: Public Works

Division Manager's Signature: 

1. Nature and purpose of agenda item:

Utility permit from City of Lake City for Goodvine and Bascom Norris.

Attach any correspondence information, documents and forms for action i.e., contract agreements, quotes, memorandums, etc.

2. Fiscal impact on current budget.

Is this a budgeted item? N/A
 Yes Account No. _____
 No Please list the proposed budget amendment to fund this request

Budget Amendment Number: _____ Fund: _____

FROM: _____ TO: _____ AMOUNT: _____

For Use of County Manager Only:

Consent Item Discussion Item

**COLUMBIA COUNTY BOARD OF COUNTY COMMISSIONERS
UTILITY PERMIT**

Date: 9/12/2018 Permit No. _____ County Road NE Bascom Norris Section No. _____

Permittee City of Lake City Utilities (Natural Gas) Department

Address 590 SW Arlington Blvd Lake City, Florida 32025 Telephone Number 386-758-5405

Requesting permission from Columbia County, Florida, hereinafter called the County, to contract, operate and maintain a proposed directional drill for a 2" medium density poly gas main at a depth of 4 feet under

the East side of NE Goodvine Way to 183 NE Bascom Norris Drive.

FROM: 1055 NE Goodvine Way TO: 183 NE Bascom Norris Drive

Submitted for the Utility Owner by: Steve Brown, Natural Gas Director

Typed Name & Title	Signature	Date
--------------------	-----------	------

1. Permittee declares that prior to filing this application it has determined the location of all existing utilities, both aerial and underground and the accurate locations are shown on the plans attached hereto and made a part of this application. Proposed work is within corporate limits of Municipality: YES NO . If YES: LAKE CITY FORT WHITE . A letter of notification was mailed on _____ to the following utility owners all City of Lake City Utilities will be notified by inter-department memo, and all others

by Sunshine State One Call of Florida.

2. The Columbia County Public Works Director shall be notified twenty-four (24) hours prior to starting work and again immediately upon completion of work. The Public Works Director is Kevin Kirby, located at 533 NW Quinten Street, Lake City, Florida Telephone Number (386) 719-1019. The PERMITTEE's employee responsible for Maintenance of Traffic is Mike DeLoach Telephone Number (386) 623-3027 (This name may be provided at the time of the 24 hour notice to starting work.)

3. This PERMITTEE shall commence actual construction in good faith within 90 days after issuance of permit, and shall be completed within 180 days after permitted work has begun. If the beginning date is more than 60 days from date of permit approval, then PERMITTEE must review the permit with the Columbia County Public Works Director to make sure no changes have occurred in the transportation facility that would affect the permitted construction.

4. The construction and maintenance of such utility shall not interfere with the property and rights of a prior PERMITTEE.

5. It is expressly stipulated that this permit is a license for permissive use only and that the placing of utilities upon public property pursuant to this permit shall not operate to create or vest any property right in said holder.

6. Pursuant to Section 337-403(1), Florida Statutes, whenever necessary for the construction, repair, improvement, maintenance, safe and efficient operation, alteration or relocation of all, or any portion of said transportation facility as determined by the Columbia County Public Works Director and/or County Engineer, any or all utilities and appurtenances authorized hereunder, shall be immediately removed from said transportation facility or reset or

relocated thereon as required by the Columbia County Public Works Director and/or County Engineer and at the expense of the PERMITTEE.

7. In case of non-compliance with the County's requirements in effect as of the approval date of this permit, this permit void and the facility will have to be brought into compliance or removed from the right of way at no cost to the County.

8. It is understood and agreed that the rights and privileges herein set out are granted only to the extent of the County's right, title and interest in the land to be entered upon and used by the PERMITTEE, and the PERMITTEE will, at all times, and to the extent permitted by law, assume all risk of and indemnify, defend, and save harmless Columbia County, Florida from any and all loss, damage, cost or expense arising in any manner on account of the exercise or attempted exercise by said PERMITTEE of the aforesaid right and privileges.

9. During construction, all safety regulations of the County shall be observed and the PERMITTEE must take measures, including pacing and the display of safety devices that may be necessary in order to safely conduct the public through the project area in accordance with the Federal Manual on Uniform Traffic Control Devices, as amended for highways.

10. Should the PERMITTEE be desirous of keeping its utilities in place and out of service, the PERMITTEE, by execution of this permit acknowledges its present and continuing ownership of its utilities located between 1055 NE Goodvine Way and 183 NE Basom Norris Drive within the County's right of way as set forth above. PERMITTEE, as its sole expense, shall promptly remove said out of service utilities whenever Columbia County Public Works Director and/or County Engineer determines said removal is in the public interest.

11. Special instructions: Minimum cover of thirty inches (30") will be required at all locations. Columbia County will not be financially responsible for any damage to facilities with less than thirty inches (30") cover. Cables shall not be located within driveway ditches.

12. Additional Stipulations: _____

It is understood and agreed that commencement by the PERMITTEE is acknowledgment and acceptance of the binding nature of these specialist instructions.

Submitted By: Steve Brown
Permittee

Place Corporate Seal

Signature and Title

Attested

Utilities Permit
Page three
Revised: 8/17/00

Recommended for Approval:

Signature: 

Title: Assistant County Manager

Date: 9-13-18

Approval by Board of County Commissioners, Columbia County, Florida:

YES () NO ()







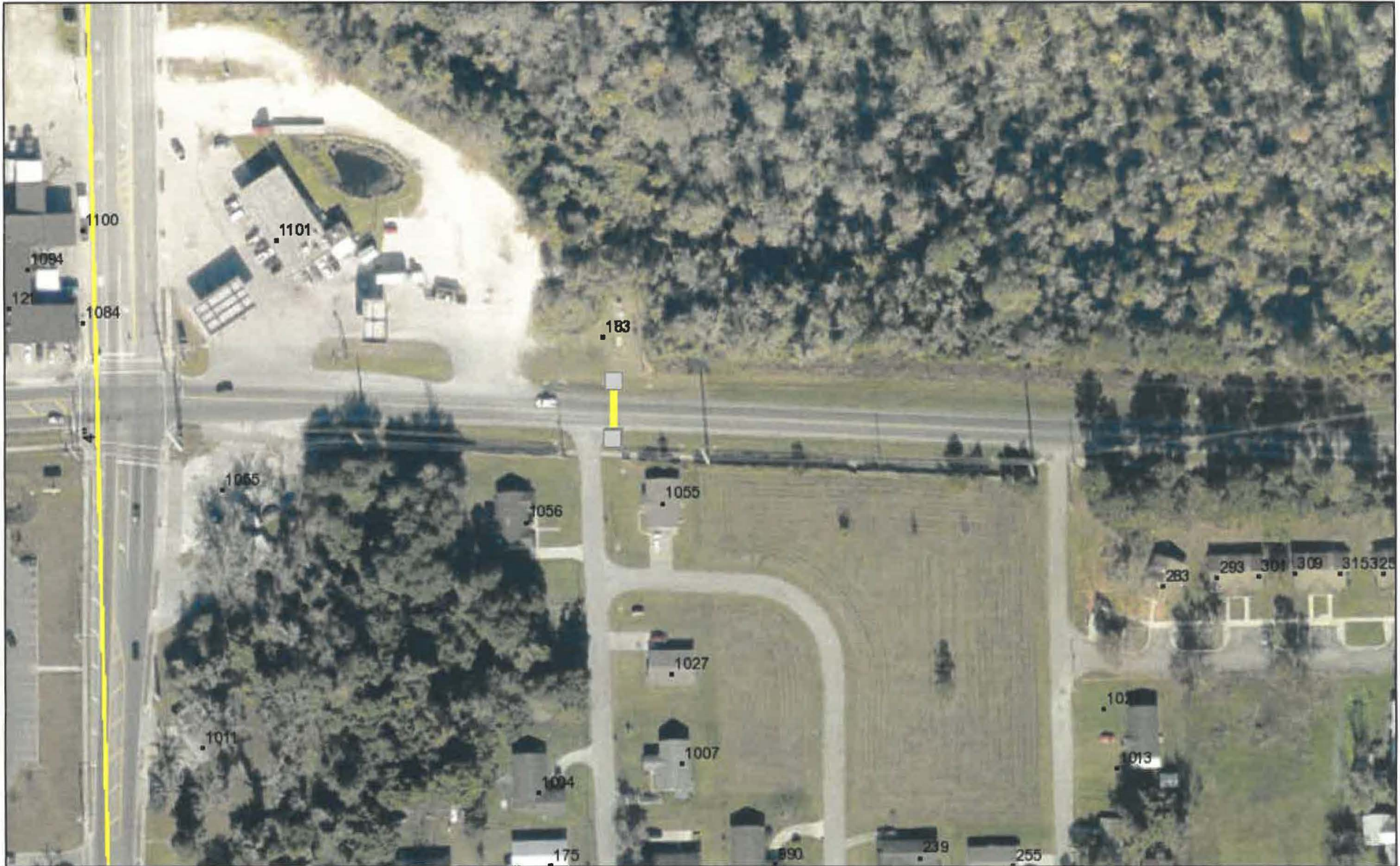

Date Approved: _____

Chairman's Signature: _____

Proposed 2" gas main



September 12, 2018

- | | | | | | | |
|--|------|---|----|---|-----------|--|
|  | 1" |  | 3" |  | 8" | |
|  | 1.5" |  | 4" |  | Addresses | |
|  | 2" |  | 6" | | | |

1:1,806

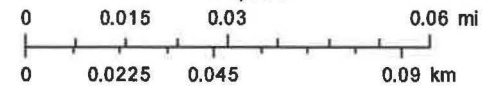

Source: Esri, DigitalGlobe, GeoEye, Earthstar Geographics, CNES/Airbus DS, USDA, USGS, AeroGRID, IGN, and the GIS User Community



COLUMBIA COUNTY BOARD OF COUNTY COMMISSIONERS
AGENDA ITEM REQUEST FORM

The Board of County Commissioners meets the 1st and 3rd Thursday of each month at 5:30 p.m. in the Columbia County School Board Administrative Complex Auditorium, 372 West Duval Street, Lake City, Florida 32055. All agenda items are due in the Board's office one week prior to the meeting date.

Today's Date: September 14, 2018 Meeting Date: September 20, 2018

Name: Kevin Kirby Department: Public Works

Division Manager's Signature: [Handwritten Signature]

1. Nature and purpose of agenda item:
Utility permit from Clay Electric for Herlong Rd.

Attach any correspondence information, documents and forms for action i.e., contract agreements, quotes, memorandums, etc.

2. Fiscal impact on current budget.

Is this a budgeted item? [X] N/A
[] Yes Account No.
[] No Please list the proposed budget amendment to fund this request

Budget Amendment Number: Fund:

FROM: TO: AMOUNT:

For Use of County Manager Only:

[X] Consent Item [] Discussion Item

**COLUMBIA COUNTY BOARD OF COUNTY COMISSIONERS
UTILITY PERMIT**

Date: 09/07/2018 Permit No. _____ County Road SW Howell Rd Section No. _____

Permittee Clay Electric Cooperative, Inc

Address PO Box 308, Keystone Heights, FL 32656 Telephone Number (352)473-8000

Requesting permission from Columbia County, Florida, hereinafter called the County, to contract, operate and maintain down guys and anchors for 25kV overhead electrical distribution line relocated as part of SW Herlong St, County Project ID 2018-02, FPID 430969-2.

FROM: STA. 401+50 (29.993263°, -82.626368°) TO: STA. 329+48 (29.995932°, -82.611650°)

Submitted for the Utility Owner by: Evan Stanley, Associate Engineer Evan Stanley 09/11/2018
Typed Name & Title Signature Date

1. Permittee declares that prior to filing this application it has determined the location of all existing utilities, both aerial and underground and the accurate locations are shown on the plans attached hereto and made a part of this application. Proposed work is within corporate limits of Municipality: YES () NO (X). If YES: LAKE CITY () FORT WHITE (). A letter of notification was mailed on _____ to the following utility owners

2. The Columbia County Public Works Director shall be notified twenty-four (24) hours prior to starting work and again immediately upon completion of work. The Public Works Director is Kevin Kirby, located at 607 NW Quinten St., Lake City, FL 32055 Telephone Number (386)719-7565. The PERMITTEE's employee responsible for Maintenance of Traffic is Jimmy Wilson Telephone Number (352)473-8000 ext. 8340 (This name may be provided at the time of the 24 hour notice to starting work.)
3. This PERMITTEE shall commence actual construction in good faith within 30 days after issuance of permit, and shall be completed within 90 days after permitted work has begun. If the beginning date is more than 60 days from date of permit approval, then PERMITTEE must review the permit with the Columbia County Public Works Director to make sure no changes have occurred in the transportation facility that would affect the permitted construction.
4. The construction and maintenance of such utility shall not interfere with the property and rights of a prior PERMITTEE.
5. It is expressly stipulated that this permit is a license for permissive use only and that the placing of utilities upon public property pursuant to this permit shall not operate to create or vest any property right in said holder.
6. Pursuant to Section 337-403(1), Florida Statutes, whenever necessary for the construction, repair, improvement, maintenance, safe and efficient operation, alteration or relocation of all, or any portion of said transportation facility as determined by the Columbia County Public Works Director and/or County Engineer, any or all utilities and appurtenances authorized hereunder, shall be immediately removed from said transportation facility or reset or Utilities Permit

relocated thereon as required by the Columbia County Public Works Director and/or County Engineer and at the expense of the PERMITTEE.

- 7. In case of non-compliance with the County's requirements in effect as of the approval date of this permit, this permit void and the facility will have to be brought into compliance or removed from the right of way at no cost to the County.
- 8. It is understood and agreed that the rights and privileges herein set out are granted only to the extent of the County's right, title and interest in the land to be entered upon and used by the PERMITTEE, and the PERMITTEE will, at all times, and to the extent permitted by law, assume all risk of and indemnify, defend, and save harmless Columbia County, Florida from any and all loss, damage, cost or expense arising in any manner on account of the exercise or attempted exercise by said PERMITTEE of the aforesaid right and privileges.
- 9. During construction, all safety regulations of the County shall be observed and the PERMITTEE must take measures, including pacing and the display of safety devices that may be necessary in order to safely conduct the public through the project area in accordance with the Federal Manual on Uniform Traffic Control Devices, as amended for highways.
- 10. Should the PERMITTEE be desirous of keeping its utilities in place and out of service, the PERMITTEE, by execution of this permit acknowledges its present and continuing ownership of its utilities located between _____ and _____ within the County's right of way as set forth above. PERMITTEE, as its sole expense, shall promptly remove said out of service utilities whenever Columbia County Public Works Director and/or County Engineer determines said removal is in the public interest.
- 11. Special instructions: Minimum cover of thirty inches (30") will be required at all locations. Columbia County will not be financially responsible for any damage to facilities with less than thirty inches (30") cover. Cables shall not be located within driveway ditches.

12. Additional Stipulations: _____

It is understood and agreed that commencement by the PERMITTEE is acknowledgment and acceptance of the binding nature of these specialist instructions.

Submitted By: Evan Stanley
Permittee

Evan Stanley Associate Engineer
Signature and Title



Tyler Taylor
Attested

Utilities Permit
Page three
Revised: 8/17/00

Recommended for Approval:

Signature: 
Title: Assistant County Manager
Date: 9-14-18

Approval by Board of County Commissioners, Columbia County, Florida:

YES () NO ()

Date Approved: _____

Chairman's Signature: _____

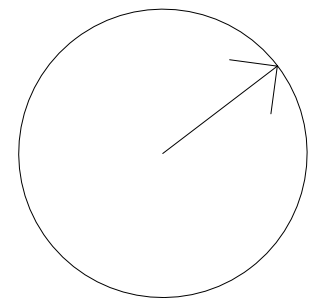
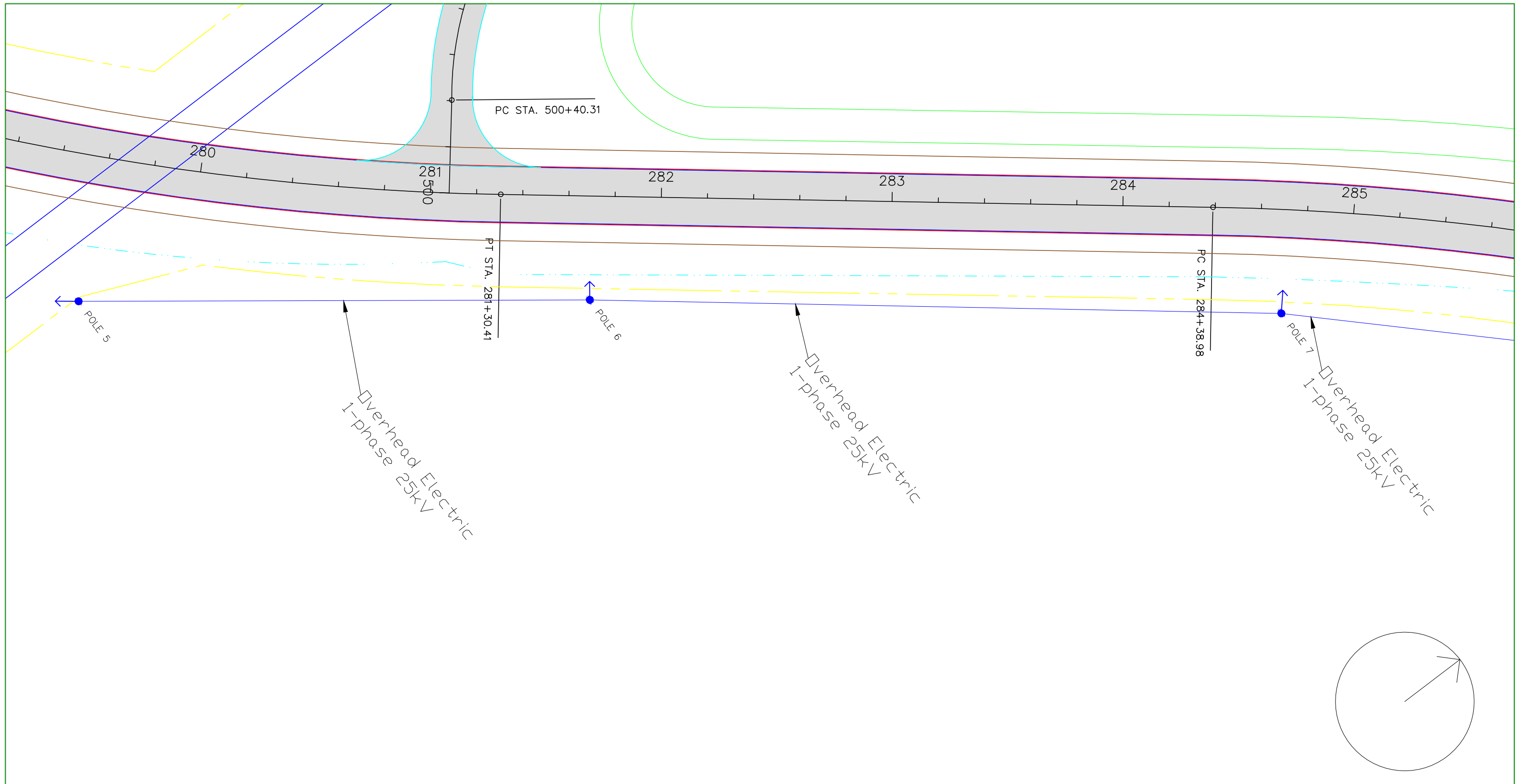

CLAY =L=CTRI □ =RATI = T □ IOX 308 K=YST = H=I HTS,	=N I =R' =VAN STANL=Y AS I-T= =N I =R, T&D PH =: -8000 =XT	□ II- □ TY PR =CT 20. -2 H=R □ TR=-T, PHAS= II =R IT APP I -TID	-LE: " = 40'	SH=T □.
				-

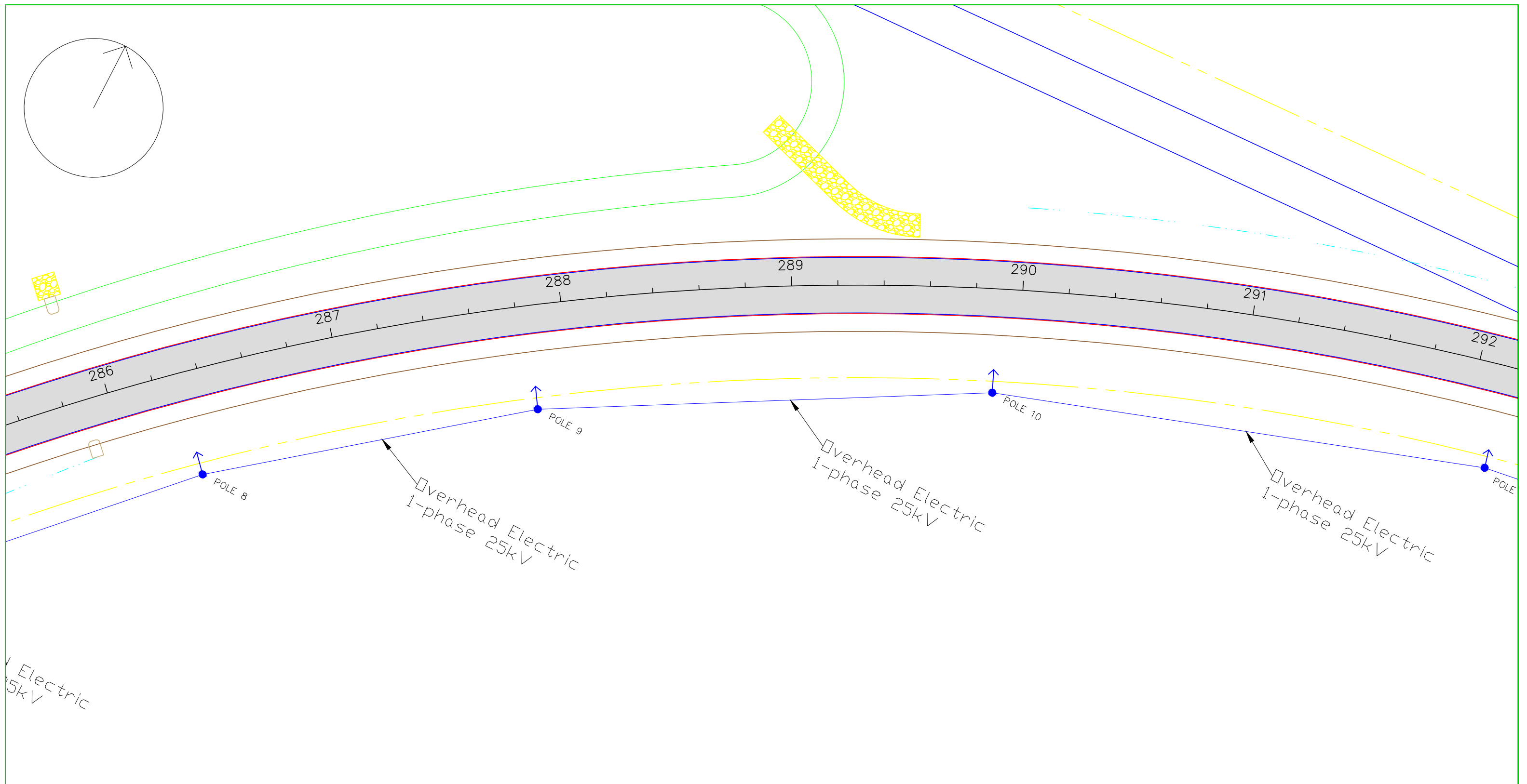
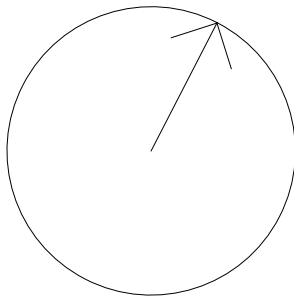

Electric
25kV

-Y =L=CTRI □ =RATI = I □ I □ X 308 K=YST = H=I HTS,	=N I =-R' =VAN STANL=Y AS I-T= =N I =-R, T&D PH =: -8000 =XT	□ II- □ TY PR =CT 20. -2 H=R □ TR=-T, PHAS= II =R IT APP I -TID	-LE: " = 40' 	SH=-T □.
---	--	---	----------------------	----------

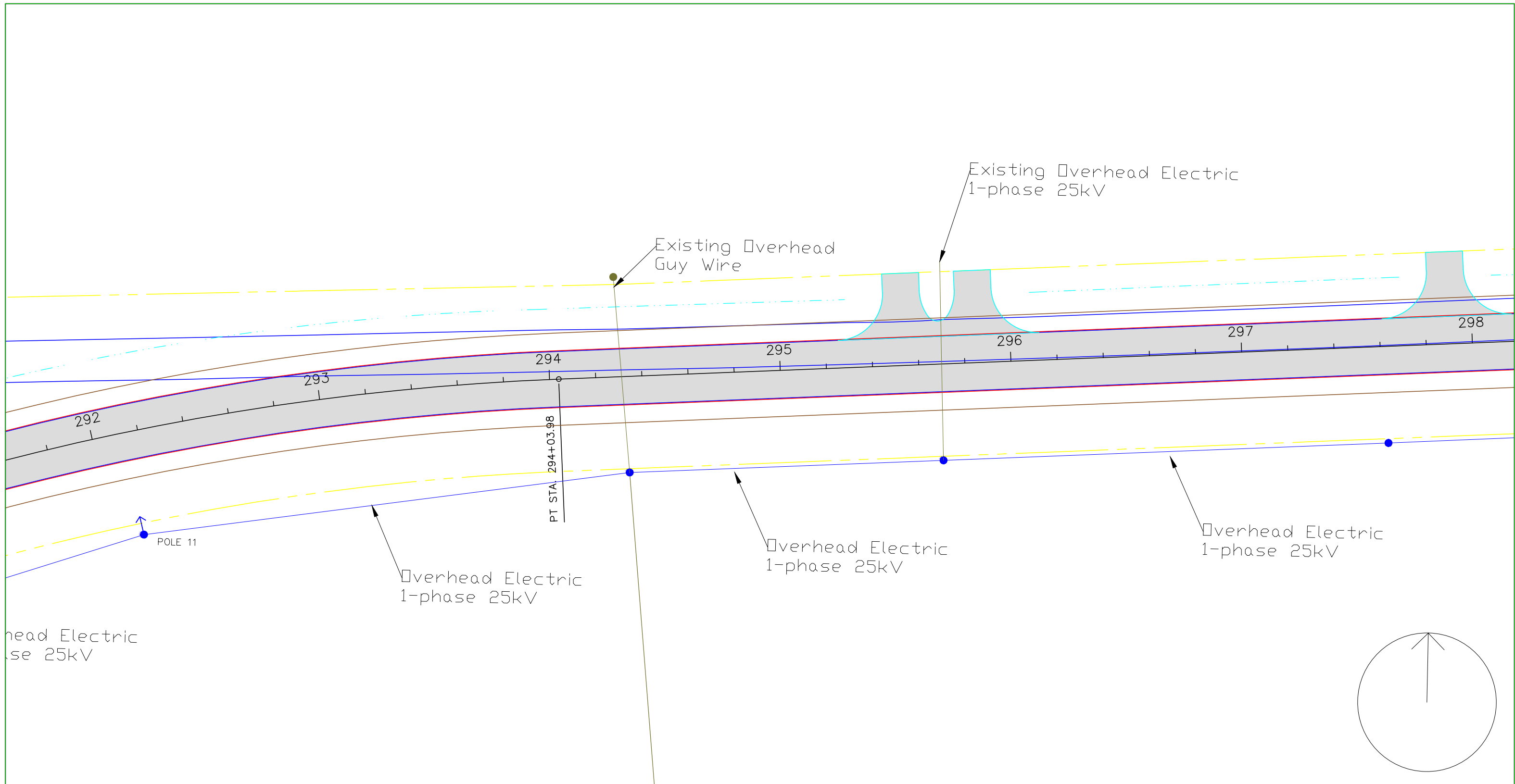

-Y = L = CTRI □ = RATT = T □ IOX 308 K = YST = H = I HTS,	= N I = = R = VAN STANL = Y AS I - T = = N I = = R, T & D PH = : -8000 = XT	□ II - □ TY PR = CT 20. -2 H = R □ TR = = T, PHAS = II = R IT APP I - TIO	-LE: " = 40' SH = = T □.
---	---	---	-----------------------------



**COLUMBIA COUNTY BOARD OF COUNTY COMMISSIONERS
AGENDA ITEM REQUEST FORM**

The Board of County Commissioners meets the 1st and 3rd Thursday of each month at 5:30 p.m. in the Columbia County School Board Administrative Complex Auditorium, 372 West Duval Street, Lake City, Florida 32055. All agenda items are due in the Board's office one week prior to the meeting date.

Today's Date: September 12, 2018 Meeting Date: September 20, 2018

Name: Kevin Kirby Department: Public Works

Division Manager's Signature: 

1. Nature and purpose of agenda item:

Utility permit from Comcast for 391 SW Woodgate Terrace

Attach any correspondence information, documents and forms for action i.e., contract agreements, quotes, memorandums, etc.

2. Fiscal impact on current budget.

Is this a budgeted item? N/A
 Yes Account No. _____
 No Please list the proposed budget amendment to fund this request

Budget Amendment Number: _____ Fund: _____

FROM: _____ TO: _____ AMOUNT: _____

For Use of County Manager Only:

Consent Item Discussion Item



9/11/2018

Columbia County Public Works Department
Attn: Connie Brecheen
607 NW Quinten St
Lake City, FL 32055

Comcast is submitting this permit request for 391 SW WOODGATE TERRACE, LAKE CITY.

If you have any questions or concerns about our drawing please feel free to contact me at the number and/or email below.

Thank you,

Jennifer Sanders
Authorized Comcast Agent
405-314-9079
sanders@fibercoregroup.com

**COLUMBIA COUNTY BOARD OF COUNTY COMISSIONERS
UTILITY PERMIT**

Date: 06/20/2018 Permit No. _____ County Road 391 SW WOODGATE TERRACE Section No. _____

Permittee FCG/Comcast

Address 13453 N. Main St. Suite 206, Jacksonville FL 32218 Telephone Number (904) 551-7859

Requesting permission from Columbia County, Florida, hereinafter called the County, to contract, operate and maintain PROPOSED UG CATV FACILITIES AT THIS LOCATION. PROJECT STARTS AT POLE 1,

RISER DOWN 25', TRENCH SW 24', TRENCH SE 144' TO POLE 2, RISER UP 25' TO END PROJECT.

FROM: 30.161329-82.932904 TO: 30.160981-82.732797

Submitted for the Utility Owner by: Jennifer Sanders - Authorized Comcast Agent *Jennifer Sanders* 9/11/2018
Typed Name & Title Signature Date

1. Permittee declares that prior to filing this application it has determined the location of all existing utilities, both aerial and underground and the accurate locations are shown on the plans attached hereto and made a part of this application. Proposed work is within corporate limits of Municipality: YES () NO (). If YES: LAKE CITY (FORT WHITE (). A letter of notification was mailed on 9/11/2018 to the following utility owners AT&T

2. The Columbia County Public Works Director shall be notified twenty-four (24) hours prior to starting work and again immediately upon completion of work. The Public Works Director is _____, located at _____ Telephone Number _____. The PERMITTEE's employee responsible for Maintenance of Traffic is _____ Telephone Number _____ (This name may be provided at the time of the 24 hour notice to starting work.)

3. This PERMITTEE shall commence actual construction in good faith within ___ days after issuance of permit, and shall be completed within ___ days after permitted work has begun. If the beginning date is more than 60 days from date of permit approval, then PERMITTEE must review the permit with the Columbia County Public Works Director to make sure no changes have occurred in the transportation facility that would affect the permitted construction.

4. The construction and maintenance of such utility shall not interfere with the property and rights of a prior PERMITTEE.

5. It is expressly stipulated that this permit is a license for permissive use only and that the placing of utilities upon public property pursuant to this permit shall not operate to create or vest any property right in said holder.

6. Pursuant to Section 337-403(1), Florida Statutes, whenever necessary for the construction, repair, improvement, maintenance, safe and efficient operation, alteration or relocation of all, or any portion of said transportation facility as determined by the Columbia County Public Works Director and/or County Engineer, any or all utilities and appurtenances authorized hereunder, shall be immediately removed from said transportation facility or reset or

relocated thereon as required by the Columbia County Public Works Director and/or County Engineer and at the expense of the PERMITTEE.

7. In case of non-compliance with the County's requirements in effect as of the approval date of this permit, this permit void and the facility will have to be brought into compliance or removed from the right of way at no cost to the County.

8. It is understood and agreed that the rights and privileges herein set out are granted only to the extent of the County's right, title and interest in the land to be entered upon and used by the PERMITTEE, and the PERMITTEE will, at all times, and to the extent permitted by law, assume all risk of and indemnify, defend, and save harmless Columbia County, Florida from any and all loss, damage, cost or expense arising in any manner on account of the exercise or attempted exercise by said PERMITTEE of the aforesaid right and privileges.

9. During construction, all safety regulations of the County shall be observed and the PERMITTEE must take measures, including pacing and the display of safety devices that may be necessary in order to safely conduct the public through the project area in accordance with the Federal Manual on Uniform Traffic Control Devices, as amended for highways.

10. Should the PERMITTEE be desirous of keeping its utilities in place and out of service, the PERMITTEE, by execution of this permit acknowledges its present and continuing ownership of its utilities located between _____ and _____ within the County's right of way as set forth above. PERMITTEE, as its sole expense, shall promptly remove said out of service utilities whenever Columbia County Public Works Director and/or County Engineer determines said removal is in the public interest.

11. Special instructions: Minimum cover of thirty inches (30") will be required at all locations. Columbia County will not be financially responsible for any damage to facilities with less than thirty inches (30") cover. Cables shall not be located within driveway ditches.

12. Additional Stipulations: _____

It is understand and agreed that commencement by the PERMITTEE is acknowledgment and acceptance of the binding nature of these specialist instructions.

Submitted By: Jennifer Sanders
Permittee

Place Corporate Seal

Jennifer Sanders Authorized Comcast Agent
Signature and Title

Attested

Utilities Permit
Page three
Revised: 8/17/00

Recommended for Approval:

Signature: _____

Title: _____

Date: _____

Approval by Board of County Commissioners, Columbia County, Florida:

YES () NO ()

Date Approved: _____

Chairman's Signature: _____

**COMCAST PERMIT REQUEST FOR
391 SW WOODGATE TER
LAKE CITY, FL**

THESE PLANS WERE PREPARED UNDER THE RESPONSIBLE CHARGE OF COMCAST FULL TIME EMPLOYEE MR. LARRY PAYNE AND ARE EXEMPT FROM THE SIGNING AND SEALING REQUIREMENTS PRESCRIBED IN SECTION 471 OF THE FLORIDA STATUTES

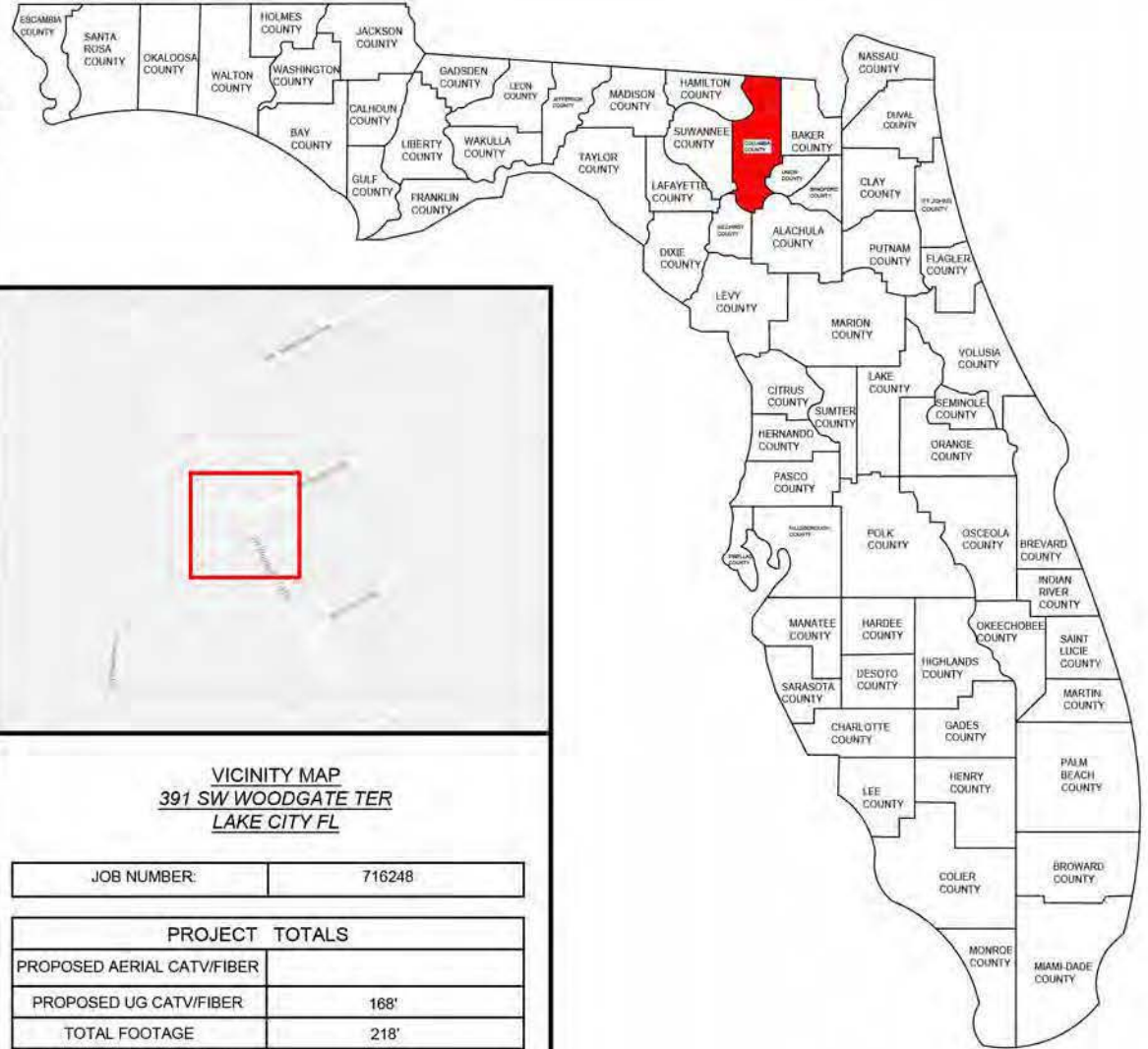

**JOB SITE:
391 SW WOODGATE TER
LAKE CITY FL**



CITY OF LAKE CITY
RIGHT-OF-WAY
PERMIT

<p> BURIED POWER — RP — BP — OP — STREET LIGHT — SL — SL — SL — WATER — WATER — SEWER — SEWER — </p>	<p> UTILITY — PROPOSED AERIAL — PROPOSED BURIED — RIGHT OF WAY — </p>	<p> CONCRETE POLE — JOINT USAGE POLE — WOOD POLE — TRANSFORMER POLE — RISER POLE — </p>	<p> Vault — ANCHOR — PEDESTAL — </p>
---	--	--	---

PROPOSED AERIAL & UG CATV / FIBER FACILITIES IN COLUMBIA COUNTY, FLORIDA

VICINITY VIEW	CITY: LAKE CITY
SHEET NO: 1 of 8	COUNTY: COLUMBIA
SCALE: NOT TO SCALE	STATE: FLORIDA
DATE: 04-09-2018	DRAWN: FIBER CORE GROUP

NOTES

ALL PROPOSED CONSTRUCTION WILL BE PER THE COLUMBIA COUNTY SPECIFICATIONS AS WELL AS ALL NECESSARY SAFETY CODES.

ALL PROPOSED CATV WILL BE WITHIN THE COLUMBIA COUNTY RIGHT-OF-WAY.

ALL PROPOSED UNDERGROUND CATV WILL BE BURIED A MINIMUM OF 36" DEEP EXCEPT ROAD BORES 48" DEEP AND DRIVEWAY BORES AT 36" DEEP.

ALL PROPOSED UNDERGROUND CATV ROAD BORES WILL USE CITY APPROVED DIRECTIONAL BORE MACHINE, AS WELL AS CITY APPROVED CONDUIT.

ALL PROPOSED CATV ROAD BORES WILL EXTEND A MINIMUM OF 8' BEYOND THE EDGE OF PAVEMENT.

ALL PROPOSED CATV DRIVEWAY BORES WILL EXTEND A MINIMUM OF 6' BEYOND THE EDGE OF PAVEMENT.

ALL PROPOSED BORES WILL BE IN A (4' X 4' X 4') PIT AND WILL USE (2) 2" HDPE CONDUIT AT 48" DEPTH USING A 5 1/4" DRILL HEAD.

ALL PROPOSED AERIAL WILL BE .700" DIAMETER AND WILL BE LASHED TO .250" STEEL STRAND CABLE USING .125" STANDARD GALVANIZED LASHING WIRE.

ALL PROPOSED AERIAL CATV CROSSING ROADWAYS WILL HAVE MINIMUM MID-SPAN HEIGHT OF 18'-0"

ALL PROPOSED AERIAL CATV CROSSING DRIVEWAYS WILL HAVE MINIMUM MID-SPAN HEIGHT OF 16'-0"

LOCATES WILL BE REQUIRED IN ALL PROPOSED UNDERGROUND AREAS AT LEAST 48 HRS PRIOR TO CONSTRUCTION.

NOTIFICATIONS TO ALL UTILITIES INVOLVED WILL BE MADE PRIOR TO CONSTRUCTION.

ALL DISTURBED AREA WITHIN THE RIGHT OF WAY WILL BE RESTORED TO ORIGINAL OR BETTER CONDITION BY GRADING AND RE-SODDING. SOD ALL AREAS DISTURBED BY CONSTRUCTION WITH BERMUDA SOD." "ALL CRACKED SIDEWALK IS TO BE REPLACED FROM JOINT TO JOINT WITHIN 7 DAYS OF WORK COMPLETION."

WORK OPERATIONS ARE TO BE MINDFUL NOT TO DAMAGE THE PAVER SIDEWALK WHEN POSITIONING EQUIPMENT. ANY DAMAGE INCLUDING TRACK MARKS WILL BE REPAIRED OR REPLACED BY THE CONTRACTOR.

CONSTRUCTION NOTES

IN ORDER TO REDUCE THE DISRUPTION AND COST OF UTILITY DAMAGES OCCURRING IN THE RIGHT-OF-WAY AND EASEMENTS, THE PERMITTEE SHALL PREVENT DAMAGES TO EXISTING UTILITIES CAUSED BY THE WORK THROUGH FIELD VERIFICATION OF THE LOCATION OF THE EXISTING UTILITIES IN CASE OF OPEN EXCAVATION. VERIFICATION MAY BE PERFORMED DURING THE PERMITTEES WORK. IN THE CASE OF DIRECTIONAL DRILLING, VERIFICATION SHALL TAKE PLACE PRIOR TO MOBILIZATION OF THE DRILLING EQUIPMENT.

THE PERMITTEE SHALL VERIFY THE LOCATION OF THE EXISTING UTILITIES AS NEEDED TO AVOID CONTACT WITH DETECTION EQUIPMENT OR OTHER ACCEPTABLE MEANS, SUCH METHODS MAY INCLUDE BUT SHALL NOT BE LIMITED TO -"SOFT DIG"- EQUIPMENT AND GROUND PENETRATING RADAR (GPR). THE EXCAVATOR SHALL BE HELD LIABLE FOR DAMAGES CAUSED TO CITY'S / COUNTIES / STATE INFRASTRUCTURE AND THE EXISTING FACILITIES OF THE OTHER UTILITY COMPANIES

ALL UTILITIES LOCATED BY VISUAL INSPECTION, TO BE VERIFIED BY LOCATES
EOT REPRESENTS EDGE OF TRAVEL NOT TRUE EDGE OF PAVEMENT
E/P REPRESENTS THE TRUE EDGE OF PAVEMENT
EOD REPRESENTS THE EDGE OF DIRT
HAND DIG TRENCHES 36" DEEP ACROSS DIRT ROAD

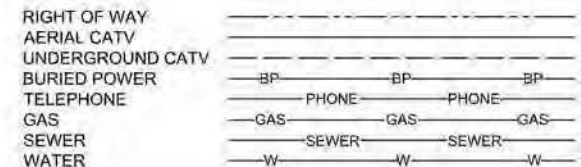

**COLUMBIA COUNTY
RIGHT-OF-WAY
PERMIT**

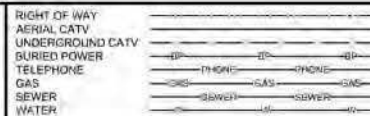

- (C) CONCRETE POLE
- (X) WOOD POLE
- (R) RISER POLE
- (□) PEDESTAL
- (V) VAULT
- (Y) ANCHOR

PROPOSED AERIAL CATV / FIBER FACILITIES IN COLUMBIA COUNTY, FLORIDA			
CONSTRUCTION NOTES		CITY:	LAKE CITY
SHEET NO: 2 OF 6		COUNTY:	COLUMBIA
SCALE: TO SCALE		STATE:	FLORIDA
DATE: 01/28/2017		DRAWN BY:	M-E-C



PROPOSED AERIAL & UG CATV / FIBER FACILITIES IN COLUMBIA COUNTY, FLORIDA			
OVERALL VIEW	CITY:	LAKE CITY	
SHEET NO: 1 of 8	COUNTY:	COLUMBIA	
SCALE: NOT TO SCALE	STATE:	FLORIDA	
DATE: 04-02-2015	DRAWN:	FIBER CORE GROUP	

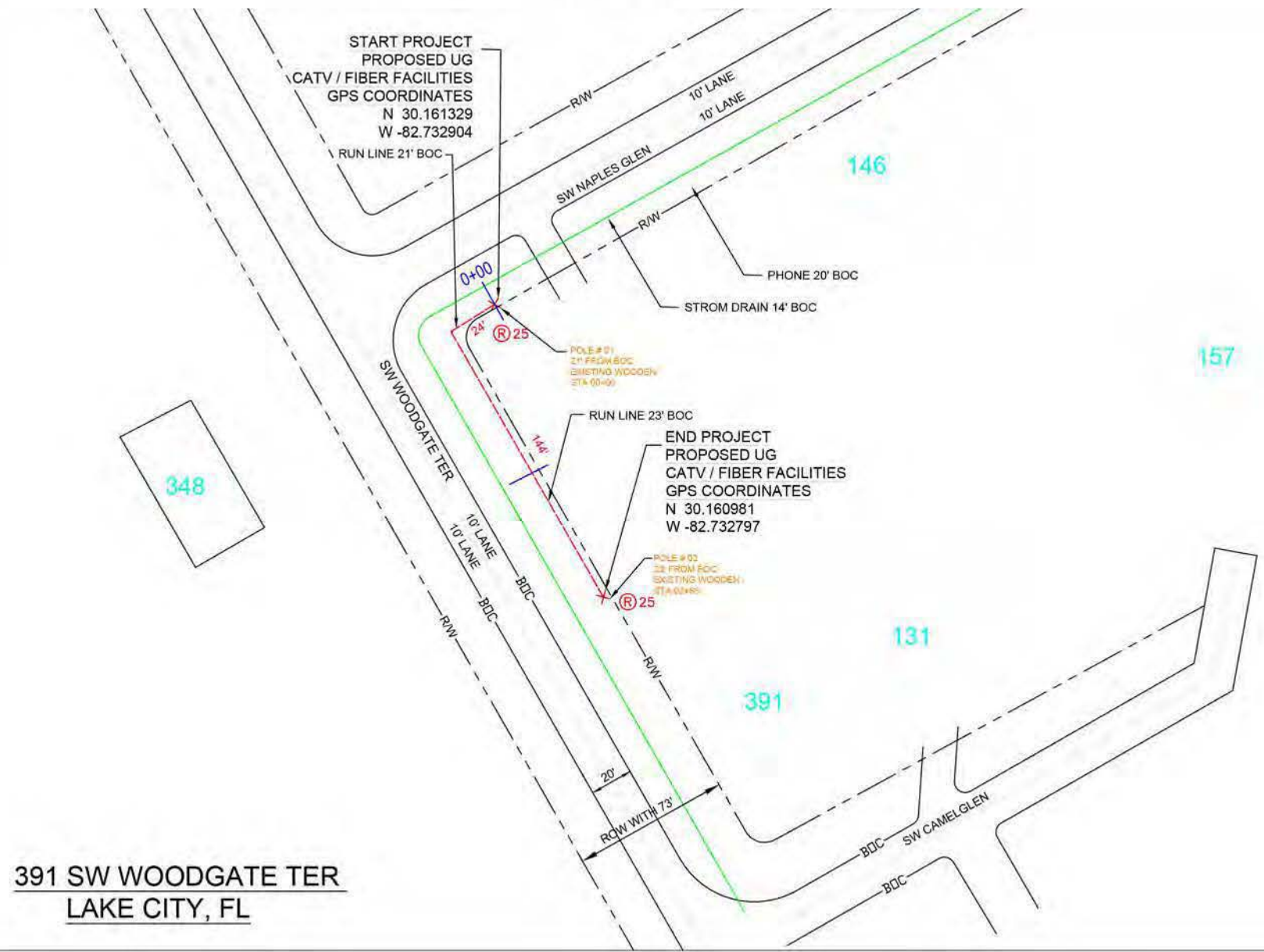

**391 SW WOODGATE TER
LAKE CITY, FL**

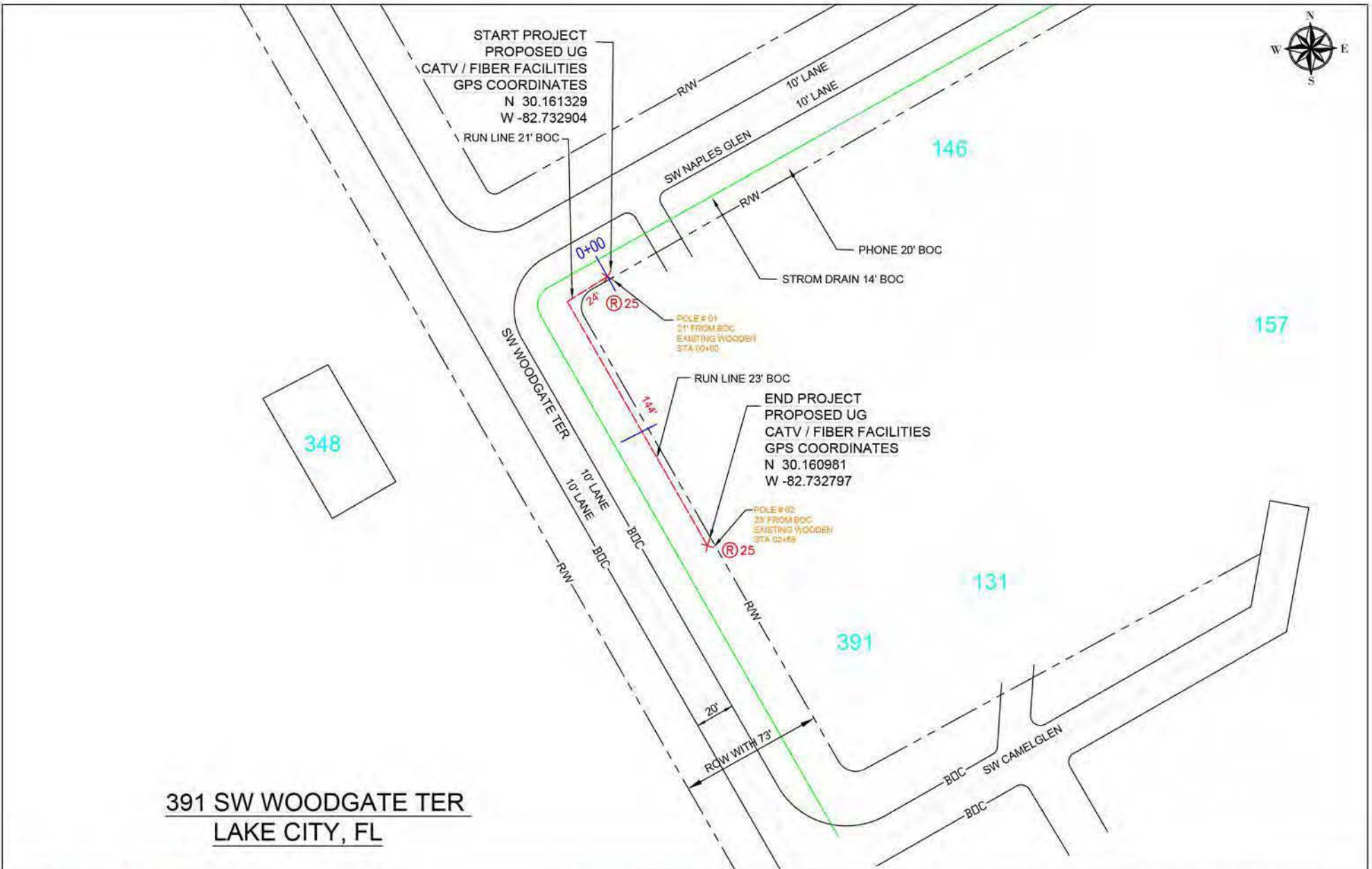

Comcast
5934 RICHARD ST
JACKSONVILLE, FLORIDA 32216

CITY OF LAKE CITY
RIGHT-OF-WAY
PERMIT

BURIED POWER	BP — BP — BP	CATV	— (P) — (P)	CONCRETE POLE	⊙	VAULT	⊞
STREET LIGHT	SL — SL — SL	PROPOSED AERIAL	— (A) — (A)	JOINT USAGE POLE	⊗	ANCHOR	⊞
TRANSFORMER	TR — TR — TR	PROPOSED BURIED	— (B) — (B)	WOOD POLE	⊗	PEDESTAL	⊞
WATER	— (W) — (W)	RIGHT OF WAY	— (R) — (R)	TRANSFORMER POLE	⊗		
SEWER	— (S) — (S)			RISER POLE	R		

PROPOSED AERIAL & UG CATV / FIBER FACILITIES IN COLUMBIA COUNTY, FLORIDA

PLAN VIEW - 01	CITY	LAKE CITY
SHEET NO. 4 of 8	COUNTY	COLUMBIA
SCALE: NOT TO SCALE	STATE	FLORIDA
DATE: 04-09-2018	DRAWN	FIBER CORE GROUP

SW WOODGATE TER, LAKE CITY, FL
CROSS SECTION

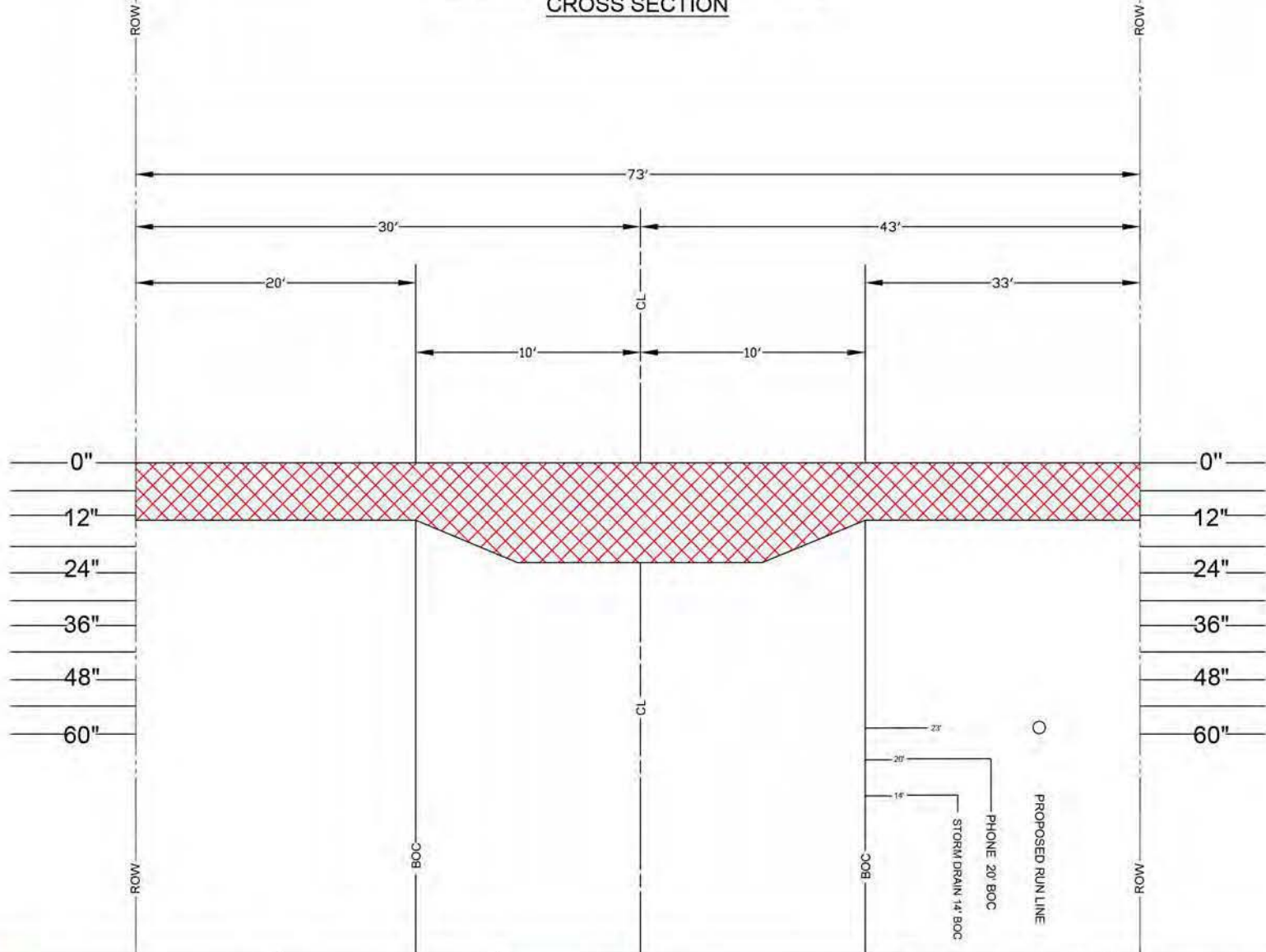

Comcast
5934 RICHARD ST
JACKSONVILLE, FLORIDA 32216

CITY OF LAKE CITY
RIGHT-OF-WAY
PERMIT

BURIED POWER — BP — BP — BP —	CAT —	CONCRETE POLE	VAULT
STREET LIGHT — SL — SL — SL —	PROPOSED AERIAL	JOINT USAGE POLE	ANCHOR
STORM DRAIN — SD — SD —	PROPOSED BURIED	WOOD POLE	PEDESTAL
WATER — W — W — W —	RIGHT OF WAY	TRANSFORMER POLE	
		R RISER POLE	

PROPOSED AERIAL & UG CATV / FIBER FACILITIES IN COLUMBIA COUNTY, FLORIDA			
CROSSSECTION	CITY	LAKE CITY	
SHEET NO. 5 of 8	COUNTY	COLUMBIA	
SCALE NOT TO SCALE	STATE	FLORIDA	
DATE: 04.09.2018	DRAWN:	FIBER CORE GROUP	

SW WOODGATE TER, LAKE CITY, FL
CITY PERMIT
602 MOT CASE

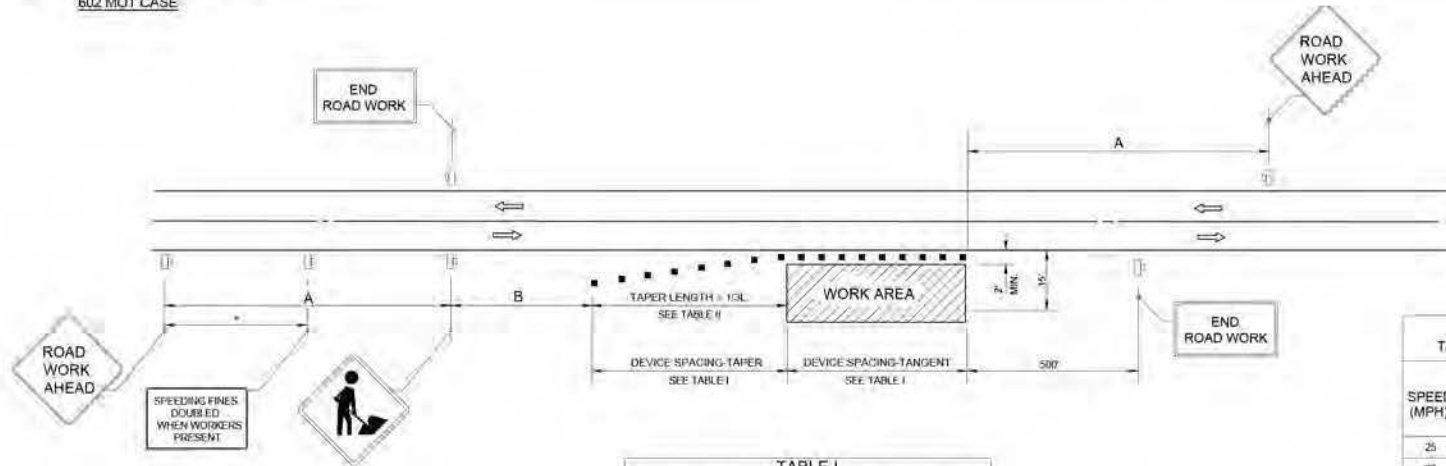

SPEED	SPACING (FT.)	
	A	B
40 MPH OR LESS	200	200
45 MPH	350	350
50 MPH OR GREATER	500	500

*MIDWAY BETWEEN SIGNS.

SPEED (MPH)	MINIMUM DISTANCE BETWEEN DEVICES (FT.)			
	CONES OR TUBULAR MARKERS		TYPE I OR TYPE II BARRICADES OR VERTICAL PANELS OR DRUMS	
	TAPER	TANGENT	TAPER	TANGENT
25	25	50	25	50
30 TO 45	25	30	30	50
50 TO 70	25	50	50	100

SPEED (MPH)	1/3L (FT)			NOTES
	8' SHLDR.	10' SHLDR.	12' SHLDR.	
25	25	35	72	L=WS 60
30	40	50	60	
35	55	38	82	
40	72	90	107	
45	120	150	180	L=WS
50	133	167	200	
55	147	183	220	
60	160	200	240	
65	173	217	260	
70	187	233	280	

8' MINIMUM SHOULDER WIDTH

1/3L = LENGTH OF SHOULDER TAPER IN FEET

W = WIDTH OF TOTAL SHOULDER IN FEET (COMBINED PAVED AND UNPAVED WIDTH)

S = POSTED SPEED LIMIT (MPH)

CONDITIONS
WHERE ANY VEHICLE, EQUIPMENT, WORKERS OR THEIR ACTIVITIES ENCRUCH THE AREA CLOSER THAN 15' BUT NOT CLOSER THAN 2' TO THE EDGE OF TRAVEL WAY

- SYMBOLS**
- WORK AREA
 - CHANNELIZING DEVICE (SEE INDEX NO. 600)
 - WORK ZONE SIGN
 - LANE IDENTIFICATION + DIRECTION OF TRAFFIC

- GENERAL NOTES**
- WHEN FOUR OR MORE WORK VEHICLES ENTER THE THROUGH TRAFFIC LANES IN A ONE HOUR PERIOD OR LESS (EXCLUDING ESTABLISHING AND TERMINATING THE WORK AREA), THE ADVANCED FLAGGER SIGN SHALL BE SUBSTITUTED FOR THE WORKERS SIGN. FOR LOCATION OF FLAGGERS AND FLAGGER SIGNS, SEE INDEX NO. 102-902.
 - SHOULDER WORK SIGN MAY BE USED AS AN ALTERNATE TO THE WORKER SYMBOL SIGN ONLY ON THE SIDE WHERE THE SHOULDER WORK IS BEING PERFORMED.
 - WHEN A SIDE ROAD INTERSECTS THE HIGHWAY WITHIN THE TTC ZONE, ADDITIONAL TTC DEVICES SHALL BE PLACED IN ACCORDANCE WITH OTHER APPLICATION TC2 INDEXES.
 - FOR GENERAL TC2 REQUIREMENTS AND ADDITIONAL INFORMATION, REFER TO INDEX NO. 102-500.

- DURATION NOTES**
- SIGNS AND CHANNELIZING DEVICES MAY BE OMITTED IF ALL OF THE FOLLOWING CONDITIONS ARE MET:
A. WORK OPERATIONS ARE 60 MINUTES OR LESS.
B. VEHICLES IN THE WORK AREA HAVE HIGH INTENSITY, ROTATING, FLASHING, OSCILLATING, OR STROBE LIGHTS OPERATING.

LAST REVISION
11/01/17

DESCRIPTION:



FY 2018-19
DESIGN STANDARDS

TWO-LANE, TWO-WAY, WORK ON SHOULDER

INDEX NO.
602

SHEET NO.
6 of 8

SW WOODGATE TER, LAKE CITY, FL
CITY PERMIT
625 MOT CASE

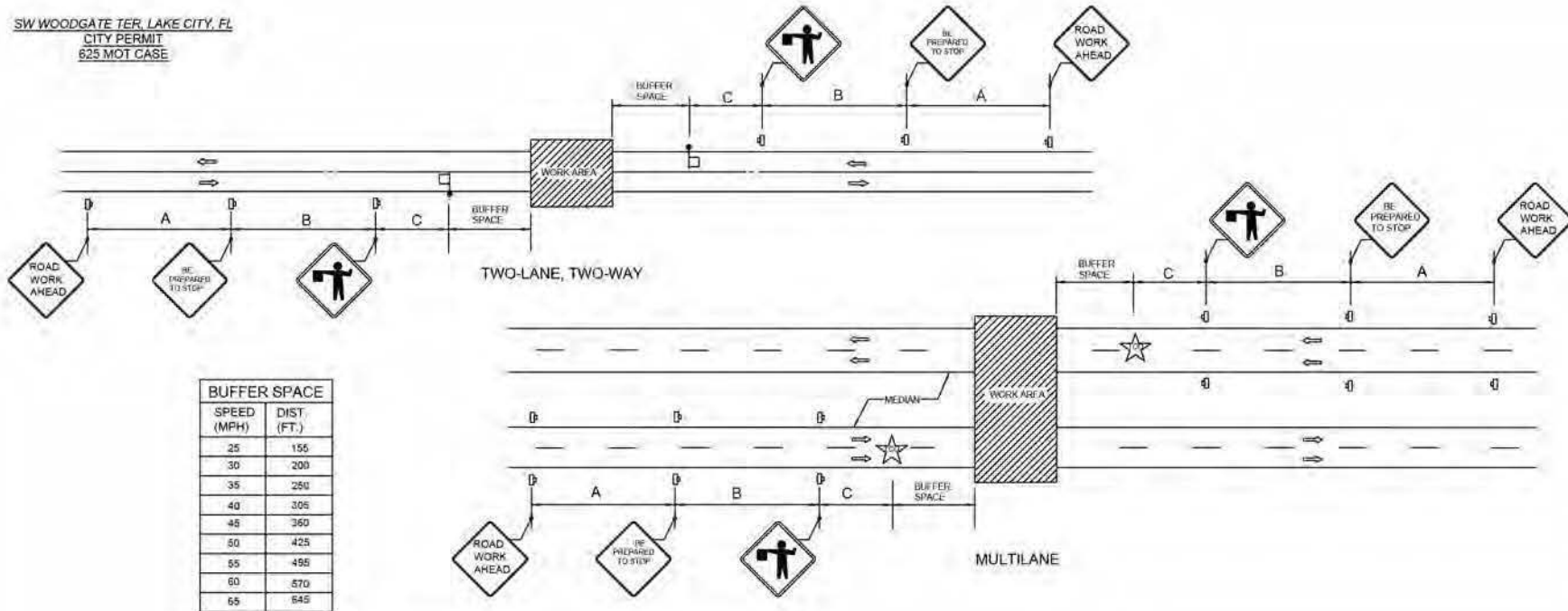

BUFFER SPACE	
SPEED (MPH)	DIST. (FT.)
25	155
30	200
35	250
40	305
45	360
50	425
55	495
60	570
65	645

SPEED (MPH)	DISTANCE BETWEEN SIGNS (FT.)		
	A	B	C
40 OR LESS	200	200	200
45	350	350	350
50 OR GREATER	500	500	500

SYMBOLS

- WORK AREA
- WORK ZONE SIGN
- FLAGGER
- TRAFFIC CONTROL OFFICER
- LANE IDENTIFICATION + DIRECTION OF TRAFFIC

GENERAL NOTES

1. THIS INDEX DOES NOT APPLY TO LIMITED ACCESS FACILITIES.
2. WHEN A SIDE ROAD INTERSECTS THE HIGHWAY WITHIN THE TTC ZONE, ADDITIONAL TTC DEVICES SHALL BE PLACED IN ACCORDANCE WITH APPLICABLE TCZ INDEXES
3. TRAFFIC VOLUME OR COMPLEXITY OF THE ROADWAY MAY DICTATE ADDITIONAL DEVICES, SIGNS, FLAGMEN AND/OR A TRAFFIC CONTROL OFFICER.
4. THE BUFFER SPACE MAY BE OMITTED IF THERE ARE NO SIGHT OBSTRUCTIONS TO VEHICLES APPROACHING THE FLAGGER/OFFICER FOR A DISTANCE EQUAL TO THE BUFFER SPACE.
5. A FLAGGER MAY BE SUBSTITUTED FOR A TRAFFIC CONTROL OFFICER AND THE BE PREPARED TO STOP SIGN MAY BE OMITTED, WHEN THE FOLLOWING CONDITIONS ARE MET:
 - A. SPEED LIMIT IS 45 MPH OR LESS
 - B. NO SIGHT OBSTRUCTIONS TO VEHICLES APPROACHING THE FLAGGER/OFFICER FOR A DISTANCE EQUAL TO THE BUFFER SPACE.
 - C. VEHICLES IN THE WORK AREA HAVE HIGH-INTENSITY, ROATING, FLASHING, OSCILLATING, OR STROBE LIGHTS OPERATING.
6. ON UNDIVIDED HIGHWAYS THE MEDIAN SIGN AS SHOWN ARE TO BE OMITTED.
7. FOR GENERAL TCZ REQUIREMENTS AND ADDITIONAL INFORMATION REFER TO INDEX NO. 600.

CONDITIONS
PLANNED CLOSURE NOT EXCEEDING 5 MINUTES

LAST REVISION
11/01/17

REVISION
DESCRIPTION



FY 2018-19
STANDARD PLANS

TEMPORARY ROAD CLOSURE 5 MINUTES OR LESS

INDEX NO.
625

SHEET NO.
7 of 8

**THE FOLLOWING DESIGN STANDARDS
ARE IN ACCORDANCE WITH THE
FLORIDA DEPARTMENT OF TRANSPORTATION
2018 600 INDEX AND APPLY TO
391 SW WOODGATE TER, LAKE CITY, FL**

- DESIGN STANDARD INDEX NO 602 (TWO LANE, TWO WAY, WORK ON SHOULDER)
- DESIGN STANDARD INDEX NO 625 (TEMPORARY ROAD CLOSURE 5 MINUTES OR LESS)



CITY OF LAKE CITY
RIGHT-OF-WAY
PERMIT

BURIED POWER — BW — BW — BW —
STREET LIGHT — SL — SL — SL —
WATER — WATER —
CATV —

PROPOSED AERIAL
PROPOSED BURIED
RIGHT OF WAY

CONCRETE POLE
JOINT USAGE POLE
WOOD POLE
TRANSFORMER POLE
RISER POLE
VAULT
ANCHOR
PEDESTAL

PROPOSED AERIAL & UG CATV / FIBER
FACILITIES IN COLUMBIA COUNTY, FLORIDA

TRAFFIC CONTROL RULES-01	CITY: LAKE CITY
SHEET NO: 8 of 8	COUNTY: COLUMBIA
SCALE: NOT TO SCALE	STATE: FLORIDA
DATE: 04-09-2018	DRAWN: FIBER CORE GROUP



COLUMBIA COUNTY BOARD OF COUNTY COMMISSIONERS
AGENDA ITEM REQUEST FORM

The Board of County Commissioners meets the 1st and 3rd Thursday of each month at 5:30 p.m. in the Columbia County School Board Administrative Complex Auditorium, 372 West Duval Street, Lake City, Florida 32055. All agenda items are due in the Board's office one week prior to the meeting date.

Today's Date: September 13, 2018 Meeting Date: September 20, 2018

Name: Kevin Kirby Department: Public Works

Division Manager's Signature: [Handwritten Signature]

1. Nature and purpose of agenda item:

Utility permit for Duckett Ct. and SW Hartridge Dr. from FPL.

Attach any correspondence information, documents and forms for action i.e., contract agreements, quotes, memorandums, etc.

2. Fiscal impact on current budget.

Is this a budgeted item? [X] N/A
[] Yes Account No.
[] No Please list the proposed budget amendment to fund this request

Budget Amendment Number: Fund:

FROM: TO: AMOUNT:

For Use of County Manager Only:

[X] Consent Item [] Discussion Item

9-5-18
COLUMBIA COUNTY BOARD OF COUNTY COMMISSIONERS
UTILITY PERMIT

Date: _____ Permit No. _____ County Road _____ Section No. _____

Permittee Florida Power & Light

Address 9001 Ellis Rd., Melbourne, FL 32904 Telephone Number 321-726-4867

Requesting permission from Columbia County, Florida, hereinafter called the County, to contract, operate and maintain Replace 2 existing wood poles with proposed wood poles

Located Along Duckett Ct and SW Heartridge Dr

MOT 603

FROM: _____ TO: _____

Submitted for the Utility Owner by: Melissa Slyter-Pratt Admn. Melissa Slyter 9/5/2018

Typed Name & Title Signature Date

1. Permittee declares that prior to filing this application it has determined the location of all existing utilities, both aerial and underground and the accurate locations are shown on the plans attached hereto and made a part of this application. Proposed work is within corporate limits of Municipality: YES () NO (). If YES: LAKE CITY () FORT WHITE (). A letter of notification was mailed on _____ to the following utility owners _____

2. The Columbia County Public Works Director shall be notified twenty-four (24) hours prior to starting work and again immediately upon completion of work. The Public Works Director is _____, located at _____ Telephone Number _____. The PERMITTEE's employee responsible for Maintenance of Traffic is _____ Telephone Number _____ (This name may be provided at the time of the 24 hour notice to starting work.)

3. This PERMITTEE shall commence actual construction in good faith within _____ days after issuance of permit, and shall be completed within 180 days after permitted work has begun. If the beginning date is more than 60 days from date of permit approval, then PERMITTEE must review the permit with the Columbia County Public Works Director to make sure no changes have occurred in the transportation facility that would affect the permitted construction.

4. The construction and maintenance of such utility shall not interfere with the property and rights of a prior PERMITTEE.

5. It is expressly stipulated that this permit is a license for permissive use only and that the placing of utilities upon public property pursuant to this permit shall not operate to create or vest any property right in said holder.

6. Pursuant to Section 337-403(1), Florida Statutes, whenever necessary for the construction, repair, improvement, maintenance, safe and efficient operation, alteration or relocation of all, or any portion of said transportation facility as determined by the Columbia County Public Works Director and/or County Engineer, any or all utilities and appurtenances authorized hereunder, shall be immediately removed from said transportation facility or reset or

relocated thereon as required by the Columbia County Public Works Director and/or County Engineer and at the expense of the PERMITTEE.

7. In case of non-compliance with the County's requirements in effect as of the approval date of this permit, this permit void and the facility will have to be brought into compliance or removed from the right of way at no cost to the County.

8. It is understood and agreed that the rights and privileges herein set out are granted only to the extent of the County's right, title and interest in the land to be entered upon and used by the PERMITTEE, and the PERMITTEE will, at all times, and to the extent permitted by law, assume all risk of and indemnify, defend, and save harmless Columbia County, Florida from any and all loss, damage, cost or expense arising in any manner on account of the exercise or attempted exercise by said PERMITTEE of the aforesaid right and privileges.

9. During construction, all safety regulations of the County shall be observed and the PERMITTEE must take measures, including pacing and the display of safety devices that may be necessary in order to safely conduct the public through the project area in accordance with the Federal Manual on Uniform Traffic Control Devices, as amended for highways.

10. Should the PERMITTEE be desirous of keeping its utilities in place and out of service, the PERMITTEE, by execution of this permit acknowledges its present and continuing ownership of its utilities located between _____ and _____ within the County's right of way as set forth above. PERMITTEE, as its sole expense, shall promptly remove said out of service utilities whenever Columbia County Public Works Director and/or County Engineer determines said removal is in the public interest.

11. Special instructions: Minimum cover of thirty inches (30") will be required at all locations. Columbia County will not be financially responsible for any damage to facilities with less than thirty inches (30") cover. Cables shall not be located within driveway ditches.

12. Additional Stipulations: _____

It is understood and agreed that commencement by the PERMITTEE is acknowledgment and acceptance of the binding nature of these specialist instructions.

Submitted By: Melissa Slyter
Permittee

Place Corporate Seal

Melissa Slyter
Signature and Title Permit Admin.

Attested

Utilities Permit
Page three
Revised: 8/17/00

Recommended for Approval:

Signature: 

Title: Assistant County Manager

Date: 9-12-18

Approval by Board of County Commissioners, Columbia County, Florida:

YES () NO ()

Date Approved: _____

Chairman's Signature: _____

Location: A/O 206 SW DUCKETT CT	Substation: NASH	Feeder: 06134
--	------------------	---------------



Inspection Date:
Management Area: NORTH FLORIDA
County: COLUMBIA
Franchise Name: COLUMBIA
BST Wire Center: LC - LAKE CITY
Pole ID: 269301593
Manufacturer: SWP
Existing Pole Height: 30
Existing Pole Class: 6
X: -82.75224100 Y: 30.16648000
Unique ID: 343764498

Remarks: Other Pole Conditions: shell rot no deduction, decayed top. Owner: fpl distribution. Accessibility: accessible by line truck. Previous Cycle Info: full excavate-external treatment. Year Last Treated: 2008. Last Treated By: osmose. Other Pole Types: service pole. Note: vines present, not cut. IWR Number: 7697035. WR Number: d00007697035. Length/Class: actual.

REPLACE POLE(S) AND TRANSFER ALL FPL FACILITIES AS REQUIRED. CUT PROP REM POLE JUST ABOVE J.U.

PREP POLE(S) FOR PULLING ONCE ALL WORK IS COMPLETE. CUT POLE(S) TO JOINT USE LEVEL ONCE ALL WORK IS COMPLETE.

REPLACE EXISTING WOOD WITH PROPOSED WOOD

RELOCATE EXISTING B-25 KVA TO NEW POLE FRAME PER DCS I-41.0.0. TX CURRENT LOAD= 64%

PRE-ARRANGED OUTAGE NOTIFICATION REQUIRED @ TLN 2-5075-4740-0-9 1 HR DURATION

MOT 603

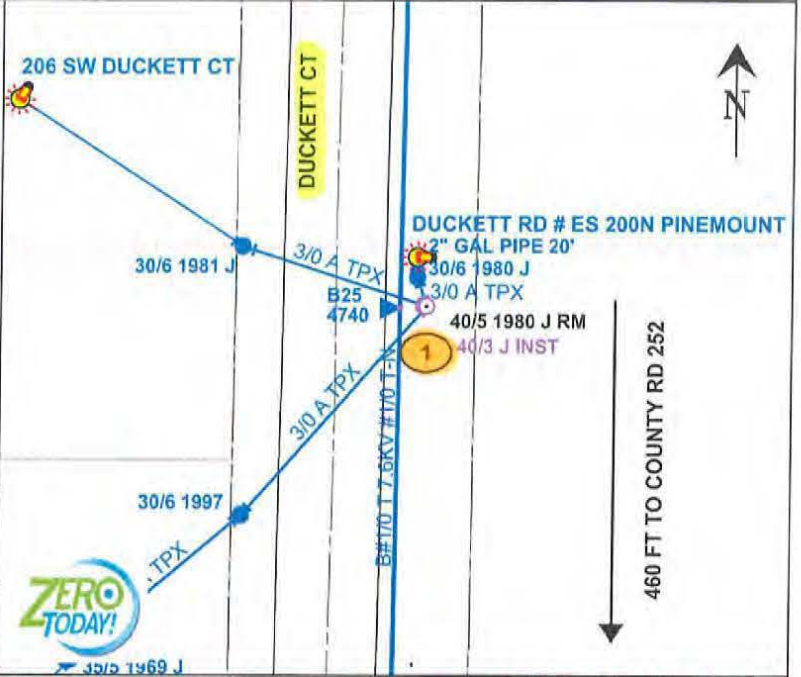

Feet of ground rod installed _____
 Ground Resistance (Ohms) _____

American Disabilities Act
 If pole placement location does not meet the minimum single point distance of 32" from edge of curb or back of sidewalk, contact your Production Lead, for further instructions.



PLEASE BE ADVISED THAT RECEIPT OF THIS DRAWING AND/OR SURVEY, WHICH IS AN APPROXIMATION, DOES NOT RELIEVE YOU OF ANY STATUTORY OBLIGATIONS, INCLUDING THE PROVISIONS CONTAINED IN SECTION 556, FLORIDA STATUTES. CALL 811 (Sunshine811) PRIOR TO ANY EXCAVATION ACTIVITIES

Replace existing wood with proposed wood

AS-BUILT CREW PRINT	ALL REQUIRED GROUND RODS HAVE BEEN DRIVEN & VERIFIED TO BE WITHIN FPL STANDARDS. VALUES ARE SHOWN AT ALL LOCATIONS.	JOB CERTIFIED COMPLETED AS SHOWN ON THIS AS-BUILT PRINT. MATERIAL CHANGES SHOWN ON ROS.	AS-BUILT COPY
Foreman's Signature _____ Date _____	Foreman's Signature _____ Date _____	Supervisor's Signature _____ Date _____	Initials _____ Cert. Date _____

Easement? []	Tree Work? []	Tree Access? []	Tree Staking Req'd? []	FPL	M/A: NF	Township: 04 Range: 16 Section 06
Designer/Stake? []	CT/Special Mtr? []	Work with SMO? []	Survey/Stake? []	306131 - 2017 PI - Pole Replacement Program		
PERMIT REQ'D	CITY []	COUNTY RD [X]	COUNTY AIR []	STATE RD []	FAA []	306131 4 NASH SUB., LAKE CITY, 32024
Requested Tel. Co. Set Poles? []	Requested Tel. Co. Transfer? [X]	Request CATV Transfer? [X]	Tele. Attachment Per _____	Job Owner: Jeffrey Corder	Date: 08/28/2018	
POLE LINE FT:	DUCT BANK FT:	Map No. LL1135	Scale: 1" = 60'	0' 60' 120'		
POLE LINE FT, ON TRANSM. POLES:	TRENCH FT:	WR: 8379922		Page 1 of 4		

PRINTED BY: vmp021r PLOT DATE/TIME: 08/28/2018 14:48:49 Size: 8 x 11

Location: SW Heathridge Dr, 3 poles S/O Hwy 90. Substation: NASH Feeder: 06134



Inspection Date: 11/01/2017 11:42:00
 Management Area: NORTH FLORIDA
 County: COLUMBIA
 Franchise Name: COLUMBIA
 BST Wire Center: LC - LAKE CITY
 Pole ID: 186015633
 Manufacturer: LAN
 Existing Pole Height: 45
 Existing Pole Class: 3
 X: -82.72551400 Y: 30.19064100
 Unique ID: 343763850

Remarks: Inspection Comments: Icoth. Owner: fpl distribution. Accessibility: accessible by line truck. Previous Cycle Info: full excavate-external treatment. Year Last Treated: 2008. Last Treated By: osmose. Other Pole Types: feeder. IWR Number: 7697035. WR Number: d00007697035. Length/Class: actual.

REPLACE POLE(S) AND TRANSFER ALL FPL FACILITIES AS REQUIRED. CUT PROP REM POLE JUST ABOVE J.U.

PREP POLE(S) FOR PULLING ONCE ALL WORK IS COMPLETE. CUT POLE(S) TO JOINT USE LEVEL ONCE ALL WORK IS COMPLETE.

REPLACE EXISTING WOOD WITH PROPOSED WOOD

MOT 603

RELOCATE EXISTING C-50 KVA TO NEW POLE FRAME PER DCS I-41.0.1. FIG 2 TX LOAD CURRENT= 2%

PRE-ARRANGED OUTAGE NOTIFICATION REQUIRED @ TLN 2-5277-1237-0-6 1 HR DURATION

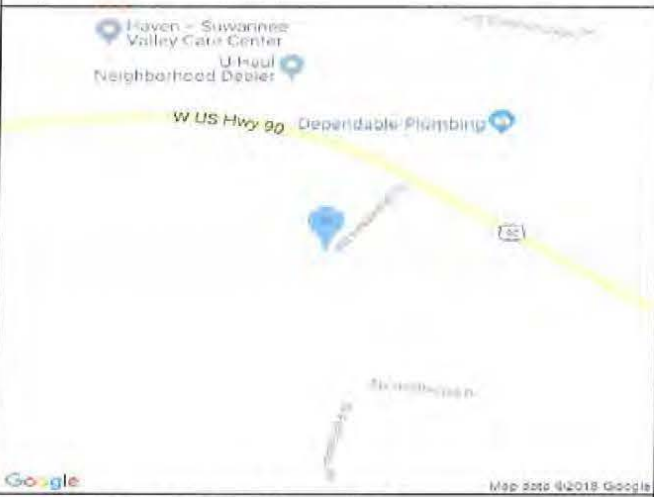

Feet of ground rod installed _____
 Ground Resistance (Ohms) _____

American Disabilities Act
 If pole placement location does not meet the minimum single point distance of 32" from edge of curb or back of sidewalk, contact your Production Lead, for further instructions.



PLEASE BE ADVISED THAT RECEIPT OF THIS DRAWING AND/OR SURVEY, WHICH IS AN APPROXIMATION, DOES NOT RELIEVE YOU OF ANY STATUTORY OBLIGATIONS, INCLUDING THE PROVISIONS CONTAINED IN SECTION 556, FLORIDA STATUTES. CALL 811 (Sunshine811) PRIOR TO ANY EXCAVATION ACTIVITIES

Replace existing wood with proposed wood

AS-BUILT CREW PRINT Foreman's Signature Date Foreman's Signature Date Supervisor's Signature Date Initials Cert. Date AS-BUILT COPY

Easement? []	Tree Work? []	Tree Access? []	Tree Staking Req'd? []	FPL	M/A: NF	Township: 03 Range: 16 Section 33
Designer/Stake? []	CT/Special Mtr? []	Work with SMO? []	Survey/Stake? []	306131 - 2017 PI - Pole Replacement Program		
PERMIT REQ'D	CITY []	COUNTY RD [X]	COUNTY AIR []	STATE RD []	FAA []	306131 4 NASH SUB., LAKE CITY, 32024
Requested Tel. Co. Set Poles? []	Requested Tel. Co. Transfer? [X]	Request CATV Transfer? [X]	Tels. Attachment Per	Job Owner: Jeffrey Corder	Date: 08/28/2018	Designer: Victor Polanco
POLE LINE FT:	DUCT BANK FT:	Map No. LF1144	Scale: 1" = 60'	0' 60' 120'		
POLE LINE FT. ON TRANS. POLES:	TRENCH FT:	WR: 8379922		Page 4 of 4		

PRINTED BY: vmp02r Size: 8 x 11 PLOT DATE/TIME: 08/28/2018 14:48:57

SYMBOLS:

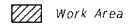
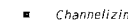
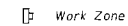
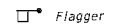
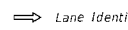
-  Work Area
-  Channelizing Device (See Index 102-600)
-  Work Zone Sign
-  Flagger
-  Lane Identification + Direction of Traffic

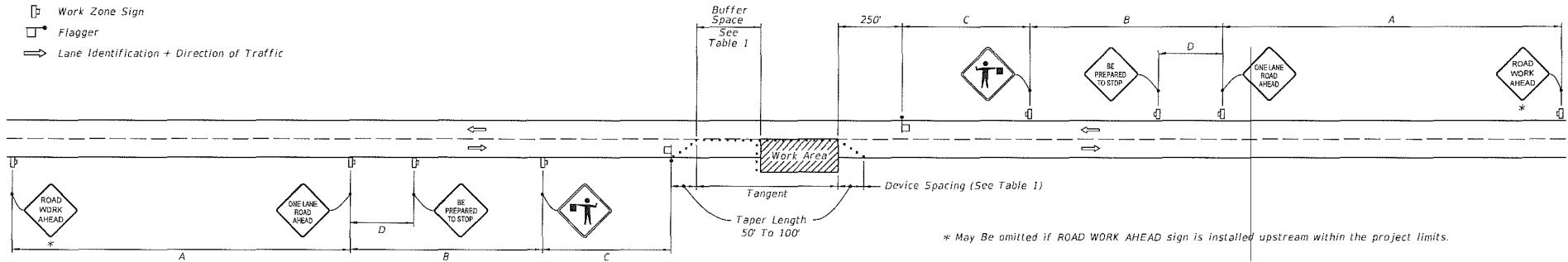

WITHOUT TEMPORARY RAISED RUMBLE STRIPS

GENERAL NOTES:

1. Special Conditions may be required in accordance with these notes and the following sheets:
 - A. Railroad Crossings:
 - a. If an active railroad crossing is located closer to the Work Area than the queue length plus 300 feet, extend the Buffer Space as shown on Sheet 3.
 - b. If the queuing of vehicles across an active railroad crossing cannot be avoided, provide a uniformed traffic control officer or flagger at the highway-rail grade crossing to prevent vehicles from stopping within the highway-rail grade crossing, even if automatic train warning devices are in place.
 - B. If the Work Area encroaches on the Centerline, use the Layout for Temporary Lane Shift to Shoulder on Sheet 3 only if the Existing Paved Shoulder width is sufficient to provide for an 11' lane between the Work Area and the Edge of Existing Paved Shoulder. Reduce the posted speed when appropriate.
2. Temporary Raised Rumble Strips:
 - A. Use when both of the following conditions are met concurrently:
 - a. Existing Posted Speed is 55 mph or greater;
 - b. Work duration is greater than 60 minutes.
 - B. Use a consistent Strip color throughout the work zone.
 - C. Place each Rumble Strip Set transversely across the lane at locations shown.
 - D. Use Option 1 or Option 2 as shown on Sheet 2. Use only one option throughout work zone.
3. Additional one-way control may be provided by the following means:
 - A. Flag-carrying vehicle;
 - B. Official vehicle;
 - C. Pilot vehicles;
 - D. Traffic signals.

When flaggers are the sole means of one-way control, the flaggers must be in sight of each other or in direct communication at all times.
4. When a side road intersects the highway within the TTC zone, place additional TTC devices in accordance with other applicable TCZ Indexes.
5. The two channelizing devices directly in front of the work area may be omitted provided vehicles in the work area have high-intensity rotating, flashing, oscillating, or strobe lights operating.
6. When Buffer Space cannot be attained due to geometric constraints, use the greatest attainable length, not less than 200 ft, for posted speeds greater than 25 mph.
7. ROAD WORK AHEAD and the BE PREPARED TO STOP signs may be omitted if all of the following conditions are met:
 - A. Work operations are 60 minutes or less.
 - B. Speed limit is 45 mph or less.
 - C. There are no sight obstructions to vehicles approaching the work area for a distance equal to the Buffer Space shown in Table 1.
 - D. Vehicles in the work area have high-intensity, rotating, flashing, oscillating, or strobe lights operating.
 - E. Volume and complexity of the roadway has been considered.
 - F. If a railroad crossing is present, vehicles will not queue across rail tracks.
 - G. AFADS are not in use.
8. See Index 102-600 for general TCZ requirements and additional information.
9. Automated Flagger Assistance Devices (AFADS) may be used in accordance with Specifications Section 102, 990 and the APL vendor drawings.





Posted Speed	DEVICE SPACING				Distance Between Signs				Buffer Space
	Maximum Spacing of Cones or Tubular Markers		Maximum Spacing of Type I or Type II Barricades/Panels/Drums		A	B	C	D	
	On a Taper	On a Tangent	On a Taper	On a Tangent					
25	20'	50'	20'	50'	200'	200'	200'	100'	155'
30	20'	50'	20'	50'	200'	200'	200'	100'	200'
35	20'	50'	20'	50'	200'	200'	200'	100'	250'
40	20'	50'	20'	50'	200'	200'	200'	100'	305'
45	20'	50'	20'	50'	350'	350'	350'	175'	360'
50	20'	50'	20'	100'	500'	500'	500'	250'	425'
55	20'	50'	20'	100'	2640'	1500'	1000'	500'	495'
60	20'	50'	20'	100'	2640'	1500'	1000'	500'	570'
65	20'	50'	20'	100'	2640'	1500'	1000'	500'	645'
70	20'	50'	20'	100'	2640'	1500'	1000'	500'	730'

CONDITIONS
 WHERE ANY VEHICLE, EQUIPMENT, WORKERS OR THEIR ACTIVITIES ENCROACH THE AREA BETWEEN THE CENTERLINE AND A LINE 2' OUTSIDE THE EDGE OF TRAVEL WAY.

10/16/2017 8:04:19 AM

LAST REVISION 11/01/17	DESCRIPTION:	FDOT	FY 2018-19 STANDARD PLANS	TWO-LANE, TWO-WAY, WORK WITHIN THE TRAVEL WAY	INDEX 102-603	SHEET 1 of 3
---------------------------	--------------	------	------------------------------	--	------------------	-----------------

SYMBOLS:

-  Work Area
-  Channelizing Device (See Index 102-600)
-  Work Zone Sign
-  Flagger
-  Lane Identification + Direction of Traffic

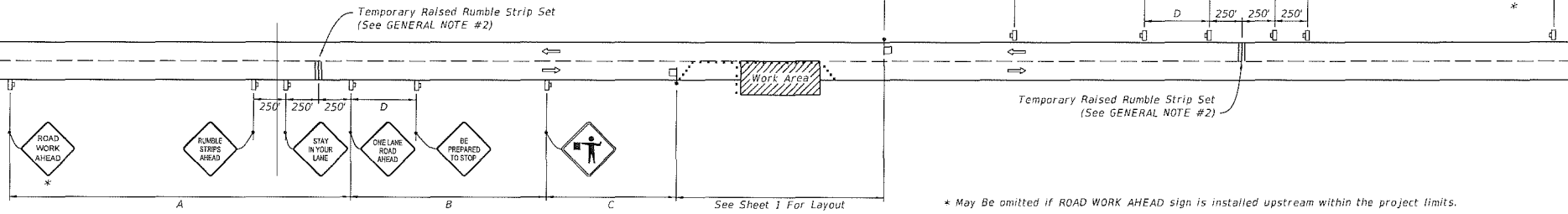

WITH TEMPORARY RAISED RUMBLE STRIPS
(When Required See GENERAL NOTE #2)

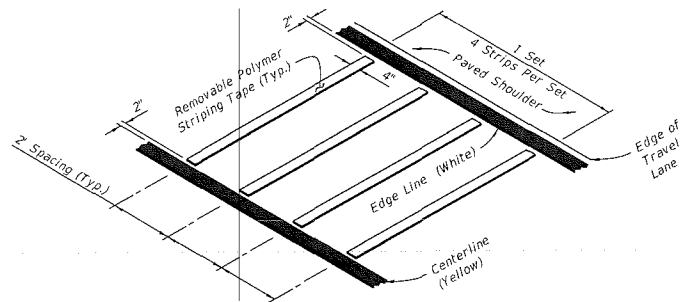

REMOVABLE POLYMER STRIPING TAPE

RUMBLE STRIP SET
OPTION - 1

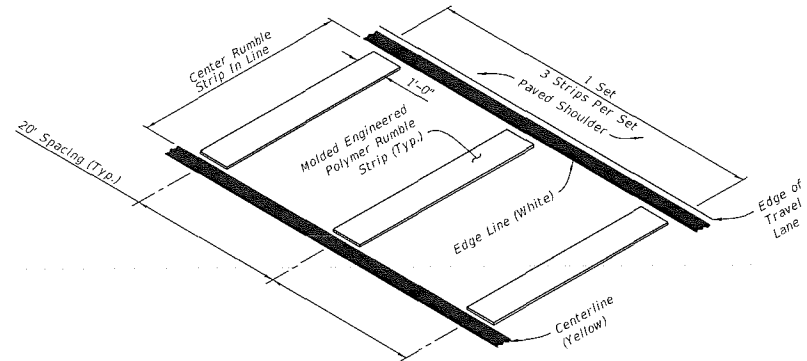

MOLDED ENGINEERED POLYMER SET





RUMBLE STRIP SET
OPTION - 2

TEMPORARY RAISED RUMBLE STRIPS

LAST REVISION 11/01/17	REVISION	DESCRIPTION:	 FY 2018-19 STANDARD PLANS	TWO-LANE, TWO-WAY, WORK WITHIN THE TRAVEL WAY	INDEX 102-603	SHEET 2 of 3
---------------------------	----------	--------------	--	--	------------------	-----------------

10/16/2017 8:04:20 AM

SYMBOLS:

-  Work Area
-  Channelizing Device (See Index 102-600)
-  Work Zone Sign
-  Flagger
-  Lane Identification + Direction of Traffic

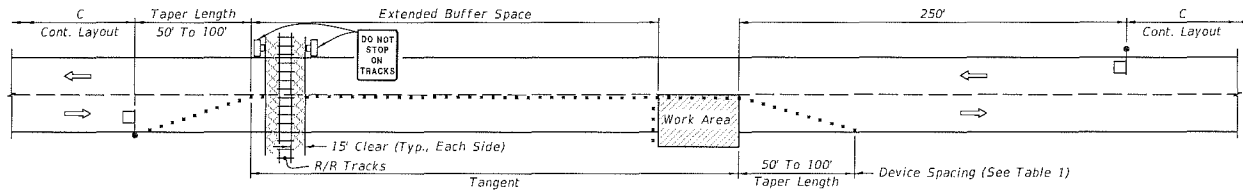

TEMPORARY RAILROAD CROSSING BUFFER SPACE EXTENSION

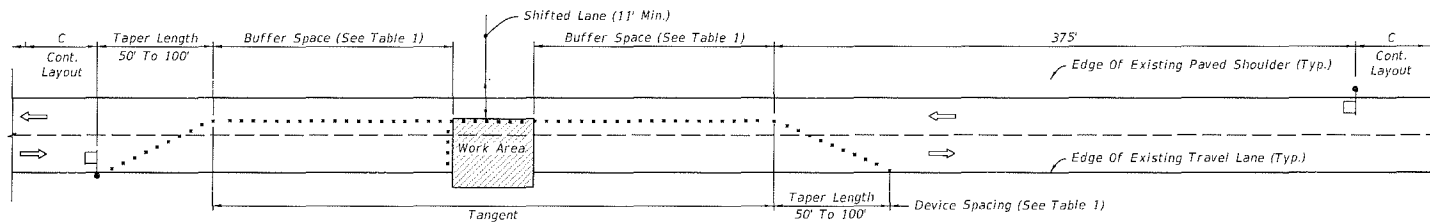

TEMPORARY LANE SHIFT TO SHOULDER WHEN WORK AREA ENCROACHES ON THE CENTERLINE

SPECIAL CONDITIONS

Cross Reference:
1. See General Note #1, Sheet 1 for more information.

10/16/2017 8:51:30 AM

LAST REVISION 11/01/17	REVISION	DESCRIPTION:	 FY 2018-19 STANDARD PLANS	TWO-LANE, TWO-WAY, WORK WITHIN THE TRAVEL WAY	INDEX 102-603	SHEET 3 of 3
---------------------------	----------	--------------	--	--	------------------	-----------------

SPECIAL CONDITIONS



**COLUMBIA COUNTY BOARD OF COUNTY COMMISSIONERS
AGENDA ITEM REQUEST FORM**

The Board of County Commissioners meets the 1st and 3rd Thursday of each month at 5:30 p.m. in the Columbia County School Board Administrative Complex Auditorium, 372 West Duval Street, Lake City, Florida 32055. All agenda items are due in the Board's office one week prior to the meeting date.

Today's Date: September 13, 2018 Meeting Date: September 20, 2018

Name: Mario Coppock Department: Recreation

Division Manager's Signature: 

1. Nature and purpose of agenda item:

BA 18-72--Request for funds to cover purchases from FY-18, due to the need for network switch replacement.

Attach any correspondence information, documents and forms for action i.e., contract agreements, quotes, memorandums, etc.

2. Fiscal impact on current budget.

Is this a budgeted item? N/A
 Yes Account No. _____
 No Please list the proposed budget amendment to fund this request

Budget Amendment Number: BA 18-72 Fund: 001-GENERAL FUND

FROM:	TO:	AMOUNT:
001-8400-584.90-99	001-7200-572.30-46	
<i>RESERVES / CONTINGENCY/RESERVE</i>	<i>OPERATING EXPENDITURES / REPAIRS & MAINTENANCE</i>	\$3,300.00

For Use of County Manager Only:

Consent Item Discussion Item



Columbia County Recreation Department

Post Office Box 1529 • 255 NE Coach Anders Lane

Lake City, FL 32056

Telephone: 386-754-7095 • Fax 386-754-7097 • Email: mario_coppock@columbiacountyfla.com

Mario A. Coppock, CPRP, CPM

Director

MEMORANDUM

DATE: September 13, 2018

TO: David Kraus, Assistant County Manager
Ben Scott, County Manager

FR: Mario Coppock, Recreation Director

A handwritten signature in blue ink that reads "M.A.C." with a stylized flourish at the end.

CC: Nicole Callum, Office Manager

RE: External Budget Amendment

I am requesting an external budget amendment in the amount of \$3,300.00 to cover expenses for the remainder of FY 17-18 for the Recreation Department. The overage in our budget is partly due to a network switch that was damaged during a storm last month and needed to be replaced in order to restore network accessibility. The cost of the switch totaled \$5,878.92 and was an unexpected expense.

The requested funds will cover the outstanding bills for the department including p-card purchases, uniform contract, fuel charges etc.

The Mission of the Columbia County Recreation Department is to meet the community's need for diverse, affordable, professionally managed recreation programs for children and adults, while maintaining a clean and safe environment.



**COLUMBIA COUNTY BOARD OF COUNTY COMMISSIONERS
AGENDA ITEM REQUEST FORM**

The Board of County Commissioners meets the 1st and 3rd Thursday of each month at 5:30 p.m. in the Columbia County School Board Administrative Complex Auditorium, 372 West Duval Street, Lake City, Florida 32055. All agenda items are due in the Board's office one week prior to the meeting date.

Today's Date: September 7, 2018 Meeting Date: September 20, 2018

Name: Kevin Kirby Department: Public Works

Division Manager's Signature: 

1. Nature and purpose of agenda item:

Approve FDACS Contract for FY 18/19

Attach any correspondence information, documents and forms for action i.e., contract agreements, quotes, memorandums, etc.

2. Fiscal impact on current budget.

Is this a budgeted item? N/A
 Yes Account No. _____
 No Please list the proposed budget amendment to fund this request

Budget Amendment Number: _____ Fund: _____

FROM: _____ TO: _____ AMOUNT: _____

For Use of County Manager Only:

Consent Item Discussion Item



BOARD OF COUNTY COMMISSIONERS • COLUMBIA COUNTY

Memo

Date: September 7, 2018
To: Kevin Kirby, Assistant County Manager
From: Ed Lontz, Solid Waste Director *EL*
RE: FY18/19 Mosquito Control Contract #025508 between
FDACS and Columbia County

Please find attached (2) two original copies of the Mosquito Control Contractual Agreement between the Department of Agriculture and Consumer Services and Columbia County for FY 18/19. The FDACS approved funding for Columbia County is not to exceed \$33,403.

The Contracts upon approval by the Board require the chair to sign on Page 13. Please return one original agreement to our office for further processing with FDACS and the BOCC may retain the other for their files.

If you have any questions regarding this information, please let me know.



Florida Department of Agriculture and Consumer Services
Division of Administration

STATE FINANCIAL ASSISTANCE RECIPIENT AGREEMENT

ADAM H. PUTNAM
COMMISSIONER

This AGREEMENT, made and entered into this ___ day of _____, by and between the FLORIDA DEPARTMENT OF AGRICULTURE AND CONSUMER SERVICES, the DEPARTMENT, and Columbia Mosquito Control, the RECIPIENT.

CONTRACT PERIOD: October 1, 2018 - September 30, 2019

SCOPE OF WORK: The RECIPIENT agrees to provide the following services:

Comply with the requirements of Chapter 388, Florida Statutes, Section 215.97, Florida Statutes, and Chapter 5E-13, Florida Administrative Code to conduct arthropod/mosquito control.

DELIVERABLES: The RECIPIENT must provide the following quantifiable, measureable and verifiable units of deliverables which must be received and accepted in writing by the contract manager before payment. These deliverables are directly related to the Scope of Work specifying minimum levels of service to be performed and criteria for evaluating the successful completion of each deliverable.

The RECIPIENT agrees to provide mosquito management/control services as specified in the above scope of work. The RECIPIENT must meet the below minimum levels of services:

- A. Submit two copies of the RECIPIENT'S operational work plan on form "Operational Work Plan for Mosquito Control" (FDACS-13666, Rev. 07/13) and detailed work plan on form "Detailed Work Plan Budget - Arthropod Control" (FDACS-13623, Rev. 07/13) shall be submitted to the DEPARTMENT no later than **July 15, 2019** as part of the application/re-application process for state aid for fiscal year 2018-2019. Any state or local funds budgeted for the control of mosquitoes in a previous fiscal year shall be estimated and re-budgeted for such control measures the following fiscal year on the RECIPIENT'S detailed work plan budget.
- B. Submit two copies of the RECIPIENT'S certified budget on the form "Annual Certified Budget for Arthropod Control" (FDACS-13617, Rev. 07/13) shall be submitted to the DEPARTMENT no later than **September 30, 2019**. If any changes are made to the Annual Certified Budget for Arthropod Control, a budget amendment on the form "Arthropod Control Budget Amendment"

- (FDACS-13613, Rev. 07/13) must be submitted to the DEPARTMENT prior to over-expending funds in any account or expending funds in non-budgeted accounts.
- C. Submit a monthly financial report to the DEPARTMENT on the form "Mosquito Control Monthly Report - State Funds" for State funds (FDACS-13650, Rev. 07/13) no later than thirty days after the end of each month for October through August reports and no later than sixty days after the close of each fiscal year for September reports.
 - D. Submit supporting documentation (i.e. receipts, travel vouchers, meeting agendas, invoices, etc.) to the DEPARTMENT with date specified for all state funds that are expended and reported on the form "Mosquito Control Monthly Report - State Funds" for State Funds (FDACS-13650, Rev. 07/13).
 - E. Submit a monthly financial report to the DEPARTMENT on the form "Mosquito Control Monthly Report - Local Funds" for Local Funds (FDACS-13663, Rev. 07/13) no later than thirty days after the end of each month for October through August reports and no later than sixty days after the close of each fiscal year for September reports.
 - F. Submit supporting documentation (i.e. receipts, travel vouchers, meeting agendas, invoices, etc.) to the DEPARTMENT with date specified for required 25% matching local funds as detailed in Rule Chapter 5E-13.030, Florida Administrative Code that are expended and reported on the form "Mosquito Control Monthly Report - Local Funds" for Local funds (FDACS-13663, Rev. 07/13).
 - G. Submit a monthly pesticide activity report to the DEPARTMENT on the form "Mosquito Control Monthly Activity Report" (FDACS-13652, Rev. 07/13) no later than thirty days after the end of each month.
 - H. Submit a copy to the DEPARTMENT of each financial reporting package containing Non-state entities' financial statements, Schedule of State Financial Assistance, auditor's reports, management letter, auditee's written responses or corrective action plan, correspondence on follow-up of prior years' corrective actions taken, and such other information determined by the Auditor General of the State of Florida to be necessary.
 - I. Execution of this contract shall serve as RECIPIENT'S acknowledgment that it is subject to Section 215.97, Florida Statutes.
 - J. This Agreement shall be executed and returned to the DEPARTMENT no later than October 1, 2018.

Intellectual property is subject to the following provisions:

- A. Anything by whatsoever designation it may be known, that is produced by, or developed in connection with this contract shall become the exclusive property of the DEPARTMENT and may be copyrighted, patented or otherwise restricted as provided by Florida or federal law. Neither the RECIPIENT nor any individual employed under this contract shall have any proprietary interest in the product.
- B. With respect to each deliverable that constitutes a work of authorship within the subject matter and scope of U.S. Copyright Law, 17 U.S.C. Sections 102-105, such work shall be a "work for hire" as defined in 17 U.S.C. Section 101 and all copyrights subsisting in such work for hire shall be owned exclusively by the DEPARTMENT.
- C. In the event it is determined as a matter of law that any such work is not a "work for hire," RECIPIENT shall immediately assign to the DEPARTMENT all copyrights subsisting therein for the consideration set forth in the contract and with no additional compensation.
- D. The foregoing shall not apply to any preexisting software, or other work of authorship used by RECIPIENT to create a deliverable but which exists as work independent of the deliverable, unless the preexisting software or work was developed by RECIPIENT pursuant to a previous contract with the DEPARTMENT or a purchase by the DEPARTMENT under a State Term Contract.

The DEPARTMENT agrees to provide the following services: N/A

The Department of Management Services' designated United Nations Standard Products and Services Code (UNSPSC) is: 85111704

The DEPARTMENT will pay the RECIPIENT as follows:

An amount not to exceed \$33,403.00 payable in equal quarterly installments upon receipt of required reports submitted to the DEPARTMENT within statutory deadlines.

Failure to meet the minimum level of services of this agreement will result in a financial consequence. The CONTRACTOR shall perform all tasks within the time frame established in this agreement.

Failure to provide the following reports by the statutory deadlines as defined in the section titled DELIVERABLES of this contract will result in a 5% reduction of that quarters invoice.

- Mosquito Control Monthly Activity Report (FDACS-13652, Rev. 07/13)
- Mosquito Control Monthly Report - Local Funds (FDACS-13663, Rev. 07/13)
- Mosquito Control Monthly Report - State Funds (FDACS-13650, Rev. 07/13)

Bills for any authorized travel expenses shall be submitted and paid in accordance with the rates specified in section 112.061, Florida Statutes, governing payments by the state for travel expenses. Authorization for travel expenses must be specified in the paragraph for payments directly above.

Bills for services shall be submitted to the DEPARTMENT in detail sufficient for a proper pre-audit and post-audit thereof.

Section 215.422, Florida Statutes, provides that agencies have five (5) working days to inspect and approve goods and services, unless bid specifications or the purchase order specifies otherwise. With the exception of payments to health care providers for hospital, medical or other health care services, if payment is not available within 40 days, measured from the latter of the date the invoice is received or the goods or services are received, inspected and approved, a separate interest penalty set by the Chief Financial Officer pursuant to Section 55.03, Florida Statutes, will be due and payable in addition to the invoice amount. To obtain the applicable interest rate, please contact the Agency's Fiscal Section at (850) 617-7200 or Purchasing Office at (850) 617-7181.

Transaction Fee: RECIPIENT shall be pre-qualified as meeting mandatory requirements and qualifications and shall remit fees pursuant to section 287.057(22), F.S., and any rules implementing section 287.057, F.S.

Invoices returned to a RECIPIENT due to preparation errors will result in a payment delay. Invoice payment requirements do not start until a properly completed invoice is provided to the DEPARTMENT.

A Vendor Ombudsman has been established within the Department of Financial Services. The duties of this individual include acting as an advocate for vendors who may be experiencing problems in obtaining timely payment(s) from a state agency. The vendor

Ombudsman may be contacted at (850) 413-5516 or by calling the Department of Financial Services' Hotline, 1-877-693-5236.

The DEPARTMENT may make partial payments to the RECIPIENT upon partial delivery of services when a request for such partial payment is made by the RECIPIENT and approved by the DEPARTMENT.

This contract may be cancelled by either party giving 30 days written notice.

The DEPARTMENT may terminate this contract at any time in the event of the default or failure of the RECIPIENT to fulfill any of its obligations hereunder. Prior to the exercise of any remedy provided for herein, the DEPARTMENT shall provide thirty (30) calendar days written notice of default and shall provide the RECIPIENT the opportunity to cure such failure or default within said thirty (30) day period. Upon the failure or inability to cure, the DEPARTMENT shall have all rights and remedies provided at law or in equity, including without limitation the following:

- A. Temporarily withhold cash payments pending correction of the deficiency by the RECIPIENT.
- B. Disallow all or part of the cost of the services not in compliance.
- C. Wholly or partly suspend or terminate this contract.

The DEPARTMENT shall have the right of unilateral cancellation for refusal by the RECIPIENT to allow public access to all documents, papers, letters or other material made or received by the RECIPIENT in conjunction with the contract, unless the records are exempt from s. 24(a) of Article I of the State Constitution and s. 119.07(1), Florida Statutes.

IF THE RECIPIENT HAS QUESTIONS REGARDING THE APPLICATION OF CHAPTER 119, FLORIDA STATUTES, TO THE RECIPIENT'S DUTY TO PROVIDE PUBLIC RECORDS RELATING TO THIS CONTRACT, CONTACT THE CUSTODIAN OF PUBLIC RECORDS:

**OFFICE OF GENERAL COUNSEL
407 SOUTH CALHOUN STREET, SUITE 520
TALLAHASSEE, FL 32399
PHONE: (850) 245-1000
EMAIL: PRCUSTODIAN@FRESHFROMFLORIDA.COM**

The RECIPIENT must:

- A. Keep and maintain public records required by the public agency to perform the service.
- B. Upon request from the public agency's custodian of public records, provide the public agency with a copy of the requested records or allow the records to be inspected or copied within a reasonable time at a cost that does not exceed the cost provided in Chapter 119, Florida Statutes or as otherwise provided by law.
- C. Ensure that public records that are exempt or confidential and exempt from public records disclosure requirements are not disclosed except as authorized by law for the duration of the contract terms and following completion of the contract if the contractor does not transfer the records to the public agency.
- D. Upon completion of the contract, transfer, at no cost, to the public agency all public records in possession of the contractor or keep and maintain public records required by the public agency to perform the service. If the contractor transfers all public records to the public agency upon completion of the contract, the contractor shall destroy any duplicate public records that are exempt or confidential and exempt from public records disclosure requirements. If the contractor keeps and maintains public records upon completion of the contract, the contractor shall meet all applicable requirements for retaining public records. All records stored electronically must be provided to the public agency, upon request from the public agency's custodian of public records, in a format that is compatible with the information technology systems of the public agency.

Extension of a contract for contractual services shall be in writing for a single period only not to exceed six (6) months and shall be subject to the same terms and conditions set forth in the initial contract. There shall be only one extension of a contract unless the failure to meet the criteria set forth in the contract for completion of the contract is due to events beyond the control of the RECIPIENT. Contracts for contractual services may be renewed on a yearly basis for no more than three (3) years, or for a period no longer than the term of the original contract, whichever period is longer. Renewal of a contract for contractual

services shall be in writing and shall be subject to the same terms and conditions set forth in the initial contract. Renewals shall be contingent upon satisfactory performance evaluations by the DEPARTMENT and subject to the availability of funds. Renewal costs may not be charged by the RECIPIENT. Exceptional purchase contracts (single source and emergency contracts) pursuant to Section 287.057(3) (a) and (c), Florida Statutes, may not be renewed.

It is mutually understood and agreed:

- A. The state of Florida's performance and obligation to pay under this contract is contingent upon an annual appropriation by the Legislature as provided in section 287.0582, Florida Statutes.
- B. Payments made under this contract are subject to the approval of the State Chief Financial Officer (Department of Financial Services).

Subject to the requirements of section 216.347, Florida Statutes, a state agency, a water management district or the judicial branch may not authorize or make any disbursement of grants and aids appropriations pursuant to a contract or grant to any person or organization unless the terms of the grant or contract prohibit the expenditure of funds for the purpose of lobbying the Legislature, the judicial branch or a state agency.

There are uniform state audit requirements for state financial assistance provided by state agencies to nonstate entities to carry out state projects in accordance with and subject to requirements of section 215.97, Florida Statutes, which may be applicable to and binding upon RECIPIENT. Nonstate entity means a local governmental entity, nonprofit organization, or for-profit organization that receives state resources. Recipient means a Nonstate entity that receives state financial assistance directly from a state awarding agency.

- A. In the event that the RECIPIENT expends a total amount of state financial assistance equal to or in excess of \$750,000 in any fiscal year of such RECIPIENT, the RECIPIENT must have a state single or project-specific audit for such fiscal year in accordance with section 215.97, Florida Statutes; applicable rules of the Department of Financial Services; and Chapters 10.550 (local governmental entities) or 10.650 (nonprofit and for-profit organizations), Rules of the Auditor General. In determining the state financial assistance expended in its fiscal year, the RECIPIENT

shall consider all sources of state financial assistance, including state financial assistance received from this department resource, other state agencies, and other nonstate entities. State financial assistance does not include federal direct or pass-through awards and resources received by a nonstate entity for federal program matching requirements.

- B. Audits conducted pursuant to section 215.97, Florida Statutes, shall be: (1) performed annually, and conducted by independent auditors in accordance with auditing standards as stated in Chapters 10.550 (local governmental entities) or 10.650 (nonprofit and for-profit organizations), Rules of the Auditor General.
- C. Regardless of the amount of the state financial assistance, the provisions of section 215.97, Florida Statutes, do not exempt a nonstate entity from compliance with provisions of law relating to maintaining records concerning state financial assistance to such nonstate entity or allowing access and examination of those records by the state awarding agency, the Chief Financial Officer, or the Auditor General.
- D. If the RECIPIENT expends less than \$750,000 in state financial assistance in its fiscal year, an audit conducted in accordance with the provisions of section 215.97, Florida Statutes, is not required. If the nonstate entity does not meet the threshold requiring the state single audit, such nonstate entity must meet terms and conditions specified in this written agreement with the state awarding agency. In the event that the RECIPIENT expends less than \$750,000 in state financial assistance in its fiscal year and elects to have an audit conducted in accordance with the provision of section 215.97, Florida Statutes, the cost of the audit must be paid from the nonstate entity's resources (i.e., the cost of such an audit must be paid from the RECIPIENT's resources obtained from other than state entities).
- E. Each state awarding agency shall:
 - (1) Provide to the RECIPIENT, information needed by the RECIPIENT to comply with the requirements of section 215.97, Florida Statutes.

- (2) Require the RECIPIENT, as a condition of receiving state financial assistance, to allow the state awarding agency, the Chief Financial Officer, and the Auditor General access to the RECIPIENT's records and the RECIPIENT's independent auditor's working papers as necessary for complying with the requirements of section 215.97, Florida Statutes. The RECIPIENT is required to maintain sufficient records demonstrating its compliance with the terms of this agreement for a period of five years from the date the audit report is issued, and shall allow the DEPARTMENT or its designee, access to such records upon request.
- (3) Notify the RECIPIENT that section 215.97, Florida Statutes, does not limit the authority of the state awarding agency to conduct or arrange for the conduct of additional audits or evaluations of state financial assistance or limit the authority of any state agency Inspector General, the Auditor General, or any other state official.
- (4) Be provided by RECIPIENT one copy of each financial reporting package prepared in accordance with the requirements of section 215.97, Florida Statutes. The financial reporting package means the nonstate entities' financial statements, Schedule of State Financial Assistance, auditor's reports, management letter, auditee's written responses or corrective action plan, correspondence on follow-up of prior years' corrective actions taken, and such other information determined by the Auditor General to be necessary and consistent with the purposes of section 215.97, Florida Statutes. Copies of the financial reporting package required by this agreement shall be submitted by or on behalf of the RECIPIENT directly to each of the following:
 - (a) The Florida Department of Agriculture and Consumer Services
Division of Administration
509 Mayo Building
407 South Calhoun Street
Tallahassee, Florida 32399-0800
 - (b) The Auditor General's Office at the following address:

State of Florida Auditor General
Room 401, Claude Pepper Building
111 West Madison Street
Tallahassee, Florida 32399-1450

- F. Any reports, management letters, or other information required to be submitted to the DEPARTMENT pursuant to this agreement shall be submitted timely in accordance with Florida Statutes, and Chapters 10.550 (local governmental entities) or 10.650 (nonprofit and for-profit organizations), Rules of the Auditor General, as applicable.
- G. The RECIPIENT shall maintain sufficient records demonstrating its compliance with the terms of this agreement for a period of five (5) years from the date the audit report is issued, and shall allow the DEPARTMENT, or its designee, Chief Financial Officer, or Auditor General access to such records upon request. The RECIPIENT shall ensure that audit working papers are made available to the DEPARTMENT, or its designee, Chief Financial Officer, or Auditor General upon request for a period of five (5) years from the date the audit report is issued, unless extended in writing by the DEPARTMENT.
- H. The RECIPIENT shall be required to ensure expenditures of state financial assistance be in compliance with laws, rules, and regulations applicable to expenditures of state funds, including, but not limited to, the Reference Guide for State Expenditures.
- I. The RECIPIENT agrees that this agreement may be charged only with allowable costs resulting from obligations incurred during the term of this agreement.
- J. The RECIPIENT agrees that any balances of unobligated cash that have been advanced or paid that are not authorized to be retained for direct program costs in a subsequent period must be refunded to the DEPARTMENT.
- K. Any funds paid in excess of the amount to which the RECIPIENT is entitled under this Agreement must be refunded to the DEPARTMENT.

It is expressly understood and agreed that any articles that are the subject of, or required to carry out, in accordance with section 287.042, Florida Statutes, this contract shall be purchased from a nonprofit agency for the blind or for the

severely handicapped that is qualified pursuant to Chapter 413, Florida Statutes, in the same manner and under the same procedures set forth in section 413.036(1) and (2), Florida Statutes; and for purposes of this contract the person, firm or other business entity carrying out the provisions of this contract shall be deemed to be substituted for the state agency insofar as dealings with such qualified nonprofit agency are concerned. Available products, pricing and delivery information may be obtained by contacting: RESPECT of Florida, 2475 Apalachee Parkway, Suite 205, Tallahassee, Florida 32301-4946, telephone number (850) 877-4816 and fax number (850) 942-7832.

It is expressly understood and agreed that any articles which are the subject of, or required to carry out, in accordance with section 287.095(3), Florida Statutes, this contract shall be purchased from the corporation identified under Chapter 946, Florida Statutes, in the same manner and under the same procedures set forth in section 946.515(2) and (4), Florida Statutes; and for the purposes of this contract the person, firm or other business entity carrying out the provisions of this contract shall be deemed to be substituted for the DEPARTMENT insofar as dealings with such corporation are concerned. The "corporation identified" is Prison Rehabilitative Industries and Diversified Enterprises, Incorporated. Available products, pricing and delivery schedules may be obtained by contacting: PRIDE of Florida, 223 Morrison Road, Brandon, Florida 33511-4835, telephone number (813) 324-8700.

The RECIPIENT is informed that a person or affiliate who has been placed on the convicted vendor list following a conviction for a public entity crime may not submit a bid on a contract to provide any goods or services to a public entity, may not submit a bid on a contract with a public entity for the construction or repair of a public building or public work, may not submit bids on leases of real property to a public entity, may not be awarded or perform work as a CONTRACTOR, supplier, subcontractor or consultant under a contract with any public entity, and may not transact business with any public entity in excess of the threshold amount provided in section 287.017, Florida Statutes, for CATEGORY TWO for a period of 36 months from the date of being placed on the convicted vendor list.

The RECIPIENT shall not discriminate on the basis of race, sex, religion, color, national origin age or disability and shall comply with all applicable state and federal laws and regulations related thereto, including without limitation, the Americans with Disabilities Act (42 USC 12101 et. Seq.); Section 504 of the Rehabilitation Act of 1973 (29 USC 795); and the Age Discrimination Act of 1975 (42 USC 6101-6107).

The RECIPIENT is informed that the employment of unauthorized aliens by any contractor is considered a violation of Section

274A(e) of the Immigration and Nationality Act. If the RECIPIENT knowingly employs unauthorized aliens, such violation shall be cause for unilateral cancellation of the contract.

The RECIPIENT is informed that an entity or affiliate who has been placed on the discriminatory vendor list may not submit a bid on a contract to provide goods or services to a public entity, may not submit a bid on a contract with a public entity for the construction or repair of a public building or public work, may not submit bids on leases of real property to a public entity, may not award or perform work as a contractor, supplier, subcontractor, or consultant under contract with any public entity, and may not transact business with any public entity.

The RECIPIENT will comply with section 20.055, Florida Statutes.

Any changes to the AGREEMENT require the written approval of each party's authorized official.

In the event that two or more documents combine to form this agreement between the parties, including future amendments and addenda, and in the event that there are contradictory or conflicting clauses or requirements in these documents, the provisions of the document(s) prepared by the DEPARTMENT shall be controlling.

All contracts entered into by the DEPARTMENT or any division or bureau thereof, are and shall be controlled by Florida law, contrary provisions notwithstanding.

In the event that any clause or requirement of this agreement is contradictory to, or conflicts with the requirements of Florida law, including, but not limited to requirements regarding contracts with Florida's governmental agencies, the offending clause or requirement shall be without force and effect and the requirements of the Florida Statutes and rules promulgated thereunder on the same subject shall substitute for that clause or requirement and be binding on all parties to this contract.

Special Conditions: N/A

The Contract Manager for the DEPARTMENT is Misty White, Agriculture Environmental Services, 3125 Conner Boulevard, Suite E, Tallahassee, Florida 32399-1650, office number (850) 617-7911, email address Misty.White@FreshFromFlorida.com.

The Contract Manager for the RECIPIENT is Ed Lontz, Director, Columbia County Mosquito Control, 1347 Northwest Oosterhoudt Lane, Lake City, Florida 32055.

State resources awarded to the RECIPIENT pursuant to this agreement and are from Florida Department of Agriculture and Consumer Services, catalog of State Financial Assistance, Mosquito Control Research, 42.003, \$33,403.00.

If state resources awarded to the RECIPIENT are to be used as matching resources for federal programs, identify the name of federal agency and catalog of Federal Domestic Assistance (title and number).

Signed by parties to this agreement:

FLORIDA DEPARTMENT OF AGRICULTURE RECIPIENT
AND CONSUMER SERVICES

<u>J.B.H.</u> Signature	_____ Signature
<u>Director of Administration</u> Title	_____ Title
<u>8-27-18</u> Date	_____ Date