

COLUMBIA COUNTY BOARD OF COUNTY COMMISSIONERS

**POST OFFICE BOX 1529
LAKE CITY, FLORIDA 32056-1529**

CONSENT AGENDA

August 3, 2017

5:30 P.M.

-
- (1) 911 Communications - Requesting Approval to Utilize E-911 Board Special Disbursement and Enter into Contract with Equature/DSS Corp. - Replace 911 Logging Recorder - BA 17-62 - \$50,000 (Pg. 1)**
 - (2) BCC Administration - Requesting Approval of Minutes - Board of County Commissioners - Regular Meeting - July 20, 2017 (Pg. 32)**
 - (3) BCC Administration - Requesting Approval for Resolution 2017R-30 - Texting While Driving Ban (Pg. 44)**
 - (4) BCC Administration - Requesting Approval of a Use of Space Agreement with the American Red Cross (Pg. 49)**
 - (5) Building and Zoning - Special Family Lot Permit (SFLP 17-40) - Beverly Stone, Mother of Courtney Bedenbaugh - Kaleb and Courtney Bedenbaugh, Property Owner - 4078 SE Country Club Road (Pg. 56)**
 - (6) Fire Rescue Department - Requesting Approval To Authorize the Application - FY 2017-2018 Florida Firefighter Assistance Grant - Purchase Personal Protective Equipment for Reservists - \$45,000 (Pg. 71)**
 - (7) Human Resource - Department of the Navy - National Naval Aviation Museum Aircraft Loan Agreement Amendment (Pg. 73)**
 - (8) Operations - Utility Permit - AT&T Florida - County Road 245 (Pg. 77)**
 - (9) Operations - Utility Permit - Florida Power and & Light Company - County Road 252 (Pg. 85)**
 - (10) Operations - Requesting Approval for a Right-of-Way Easement - Clay Electric Coop. - Ellisville Fire Station (Pg. 103)**
 - (11) Purchasing - Requesting Approval - Award Bid No. 2017-Q to Low Bidder Sun Professional Supply - \$46,980 (Pg. 107)**
 - (12) Recreation - Requesting Approval of Amendment for a New Network Switch and Surveillance Camera - BA 17-63 - \$2,620 (Pg. 111)**



1

COLUMBIA COUNTY BOARD OF COUNTY COMMISSIONERS AGENDA ITEM REQUEST FORM

The Board of County Commissioners meets the 1st and 3rd Thursday of each month at 5:30 p.m. in the Columbia County School Board Administrative Complex Auditorium, 372 West Duval Street, Lake City, Florida 32055. All agenda items are due in the Board's office one week prior to the meeting date.

Today's Date: July 25, 2017 Meeting Date: August 3, 2017

Name: Tom Brazil Department: 9-1-1 Communications Center

Division Manager's Signature: Ben Scott

1. Nature and purpose of agenda item:

Request to utilize E-911 Board Special Disbursement and enter into contract with Equature / DSS Corp to replace 911 logging recorder at 911 Communications Center. BA 17-62; total amendment \$50,000.

Attach any correspondence information, documents and forms for action i.e., contract agreements, quotes, memorandums, etc.

2. Fiscal impact on current budget.

- Is this a budgeted item?
- N/A
 - Yes Account No. _____
 - No Please list the proposed budget amendment to fund this request

Budget Amendment Number: BA 17-62 Fund: 001-GENERAL FUND

FROM:	TO:	AMOUNT:
001-0000-342.40-12 TELE ASSMNT NON-WIRELESS / SPECIAL DISBURSEMENTS	001-2510-525.30-46 OPERATING EXPENDITURES / REPAIRS & MAINTENANCE	\$25,000.00
001-0000-342.40-12 TELE ASSMNT NON-WIRELESS / SPECIAL DISBURSEMENTS	001-2510-525.30-64 OPERATING EXPENDITURES / NON-CAPITAL EQUIPMENT	\$25,000.00

For Use of County Manger Only:

Consent Item Discussion Item



COLUMBIA COUNTY, FLORIDA
9-1-1 COMMUNICATIONS CENTER
263 NW LAKE CITY AVE.
LAKE CITY, FL 32055
(386) 758-1125
FAX (386) 758-1386

MEMORANDUM

DATE: July 25, 2017

TO: Ben Scott County Manager

FR: Thomas W. Brazil
Manager / 911 Coordinator
911 Communications Center

RE: Request for Agenda Item to Approve Contract with Equature / DSS Corp for replacement of the logging recorder at the 911 Communications Center

As you are aware, Columbia County received a \$50,000.00 Special Disbursement from the State E-911 Board in March 2017 (see attached). These funds are restricted for 911 equipment that will aid in transitioning toward Text to 911 or NG911 services. Being we already have Text to 911 capabilities and are moving toward NG911 I would like to utilize these funds to replace our logging recorder. Our current analog Exacom logging recorder is five (5) years old, which qualifies for replacement under E-911 Board guidelines as well as our critical infrastructure equipment replacement / refresh cycle of five (5) years. I have worked with vendors and obtained quotes from three vendors that supply 911 logging recorders, Replay Systems, Word Systems Inc. NICE and Equature (DSS Corp). The replacement recorder suitable for our needs must be NG911 capable, compatible with our pending P25 digital radio system and upgradable in the future. Of the three quotes obtained, Equature (DSS Corp.) was the least expensive as well as providing the recorder at GSA Contract pricing under GSA Contract #GS-35F-079DA. I am seeking Board approval utilize the State Special Disbursement in the amount of \$50,000.00 combined with existing budgeted funds to enter into a contract with Equature / DSS Corp. for replacement of our logging recorder with the specifications outlined in the attached quote in the amount of \$54,521.00. In addition, AK Associates our current 911-equipment maintenance vendor is also a partner with Equature / DSS Corp. and will maintain our new system.

Replay quote = \$57,645.00 Nice quote= \$65,146.00 Equature / DSS Corp quote = \$54,521.00



Florida E911 Board
 4030 E. Colonial Way
 Tallahassee, FL 32309-0950
 TEL: (904) 227-7491
 FAX: (850) 488-9837
 URL: <http://Florida911.org/myflorida.org>

March 24, 2017

Florida E911 County Coordinators

At the March 15, 2017 E911 Board meeting, the Board approved the 911 Coordinator Meeting and Training Disbursement. The E911 Board was pleased to approve financial support for counties to send their county 911 coordinator to the 2017 Florida APCO/NENA Conference that will held May 21-24, 2017, in Daytona Beach Florida.

This disbursement will be sent to each county that sends their 911 County Coordinator or designee to attend the training conference. As in the past, each county will be reimbursed \$1200.00 to help offset the cost of their representative attending the conference. The funds are for travel, lodging and per diem expense related to attending the conference.

The Florida E-911 Board has specifically requested that each county representative sign the attendance sheet that will be provided at the coordinator meeting. This sign-in sheet will determine the counties that receive the reimbursement.

Please take advantage of this valuable training that the E911 Board is supporting. The opportunity to collaborate with fellow 911 coordinators, discuss issues, and share solutions will enhance the 911 service in the state of Florida.

Please contact me at (850) 921-0041 or at Leon.Simmonds@dms.myflorida.com if you have any questions concerning this disbursement.

Leon Simmonds
 Statewide E911 Coordinator

Board Members: Laurene J. Anderson - HAMIL BEACH - Carolyn Dittmuller - Chesley Dillon - Benjamin S. Guthrie
 David E. Kinch - Dale W. Mitchell - Tomer Madler - Christie A. Potts - Ira J. Pyles

We serve those who serve Florida.



Strategic Partners



Police · Fire · EMT · Military · Security

July 17, 2017

Tom Brazil
Columbia County Combined Emergency Communications Center
263 NW Lake City Avenue
Lake City, FL 32055



RE: Strategic Long-Term Partnership with the Columbia County Combined Emergency Communications Center Team

Thank you for investing your valuable time with Equature. We appreciate the opportunity to partner with the Columbia County Combined Emergency Communications Center Team. Our vision is to help others help themselves. Dispatch centers are under tremendous stress 24x7x365 and it is our job as your strategic partner to help improve dispatch operations. We do this by focusing our resources on NG9-1-1 Recording and Dispatch Improvement because like you, we understand that **SECONDS SAVE LIVES®**.

To be your strategic long term partner, we must provide a robust NG9-1-1 recording platform that is based on **Simplicity.Reliability. Speed®**. Your team's time is valuable and Equature® is designed as a mission critical tool to save your team time. Dispatch Improvement tools are required today so your team can perform and improve every day. We understand the frustration with slashed training budgets, dispatch turnover, head count reduction and often no standardized training guidelines. Improving dispatch operations requires state of the art tools. Basically, your team is required to do more with less and as your partner it is our job to deliver them.

We understand that we have to earn your TRUST in order to establish a long term partnership. Here are the guidelines for a great partnership:

1. **They must be mutually beneficial:** We have to deliver state of the art solutions based on **Simplicity.Reliability. Speed** so your team can perform their jobs better because **Seconds.Save.Lives®!** Your agency has to provide feedback and suggestions to help make Equature better.
2. **Must be easy to work together and be open to learn from each other:** We have 20+ year relationships with our clients today and the key to that success is simplicity in working together. We all understand the problems with overseas support, foreign call centers and red tape. Equature is a U.S. based company and we manufacture, sell, support, train and implement your solution A to Z. We work hard to make sure we are easy to work with. This is why we give our CEO's cell phone number out to guarantee your satisfaction (248-752-7301).
3. **Partnerships must provide high value to both parties:** Our Equature® NG9-1-1 Recording and Dispatch Improvement platform is neither the least or the most expensive on the market. One thing we do guarantee is that you will get three times the value on your investment. This is why we offer a 100% Money Back Guarantee.

Here are some key highlights about us:



1. EQUATURE is a member of the INC 500/5000 list of fastest growing companies in America four years running.
2. EQUATURE sponsors and chairs several NENA and APCO NG9-1-1 standard's committees. We wrote the logging service requirements for NENA which are a core component of NG9-1-1 Recording. We participate in all NENA ICE (Industry Collaboration Events) and have been a NENA NG partner since 2008.
3. EQUATURE focuses on a direct marketing model. We manufacture, sell, support, service and train all right here in the United States. We provide 24x7x365 Proactive Onsite Support anywhere in the U.S. within 4 hours. Our EQUATURE Direct Advantage model allows us to build functionality faster based on our PSAP client's needs.

Some key highlights of the Equature® NG9-1-1 Performance platform:

1. **100% Content Search-** The Equature NG9-1-1 Performance Suite allows you to search for calls from any device like your MDT, Android tablet, iPhone, iPad and MAC based on words or phrases spoken during the call. For quality assurance, you can even search for calls based on certain words or phrases that were not spoken. This allows 100% of the content of the calls to be searched now!
2. **Dispatch Improvement Cycle –** The Equature NG9-1-1 Performance Suite provides a full auditable dispatch improvement platform for assessing dispatcher's response by call type, reporting/analytics and learning on demand training content. *Example: John does a good job of handling calls but scores low on telephone skills. With EQ you simple deliver the 8-hour Customer Service course and re-evaluate future calls and track John's improvement.* This is unique in the industry.
3. **CAD Capture –** Our seamless CAD Capture Module allows the user to automatically create scenarios based on call types from CAD (EIDD) and automatically populates data from CAD into Equature for advanced searching and reporting. This saves hours and hours every week for your team.
4. **One Integrated Platform –** The Equature NG9-1-1 Performance Suite is one integrated platform to capture all NG9-1-1 content (VoIP, RoIP, SMS/MMS, Video, Mobile, Telematics, Police InCar/BWC Video, logging service, EIDD). You have access to search, report, share, and assess all in one system. No other company provides this which means you are protecting your investment for the future. All of the software is written by us and NOT taped together from several companies.



5. **Next Generation 911 Capture** – This means you do NOT have to buy a new system when your center has to accept other types of emergency communications like (text messaging (SMS & MMS), picture and video attachments, live streaming video, telematics, and additional NG9-1-1 communications).
6. **Motorola P25 Astro / ISSI RoIP** – The Equature NG9-1-1 Platform is a leader for Motorola Validated radio recording. We have very unique features that allow us to share talk groups amount different agencies to save significant investment dollars. We saved one client \$1 Million dollars with this feature. *See solution brief for details.*
7. **Visual Mapping Standard** – In English this means you can map your 911 calls and see exactly where they came from and you can do this from any search over any time period. This helps for proactive patrolling.
8. **Redaction, Cropping, and Notes Package** – Redaction is a new technology that allows the administrator of the system the ability to redact or “beep tone” out any personal or privileged information when creating a copy of a recording. Cropping is the ability to identify a meaningful segment of the call. Notes are the ability to place a note or tag for a call. This visual reminder is a way to easily go to the exact spot of the call at a later date.
9. **Dashboard view** allows you to customize and view which information is most important to you and have that delivered to a single screen. This could be reports, mapping of calls, live monitor, multiple channel replay, etc. and anything else that you would like to see. This can be configured by user.
10. **Screen Recording** allows for the Dispatch computer screen(s) to be recorded and played back with the audio, (like a movie). You can not only hear what was said but see what they did as it happened during the incident.
11. **Quality Assessment Grading** allows for the scoring of dispatch calls helping to identify training opportunities and validating previous training sessions. Demonstrates the agency is being proactive in addressing deficiencies in dispatcher performance. Research shows that regular review of dispatchers’ performance has a highly positive effect on their overall performance.
12. **Elite Performance Training** is a state of the art online learning platform designed to provide Public Safety telecommunicators world class course training. Courses are broken into 20-45-minute video slices with summaries, documents and quizzes. Research shows that retention is



improved by 70% when content is delivered in bite sized chunks. Equature is very operationally focused and knows training is critical to the success of any dispatch center because seconds save lives.

13. **Future Proof** – The Equature NG9-1-1 Performance Suite is built on interoperable and non-proprietary data. This means that the latest software release is compliant with all data from day one. This means we can make sure our system can run for 30 years in your center and always be new. We are a software company and we would simply update to new hardware.

Why partner with Equature?

1. Next Generation 9-1-1 and EIDD Technology leader and NENA/APCO Partner since 2008
2. APCO/NENA PSAP Working Group – Co-Leader, Michael Smith, EQUATURE Chief Technologist
3. Patent pending Mobile Capture and Automated Scenario Reconstruction
4. Participant & committee member in all NENA Industry Collaboration Events (ICE)
5. ICE Steering Committee – Michael Smith – Vendor Representative
6. ICE 8: Interoperability with Recording & Logging Components – Michael Smith – Planning Committee Chairman
7. NG9-1-1 Standard for the Logging Service – Technical work completed by Michael Smith
8. Deal directly with a US Based manufacturer – not U.S. Regional Sales Office & Overseas manufacturer and a reseller that changes brands or worse handles multiple lines. Impossible to properly stock parts and be an expert on every system.
9. Large enough to provide the BEST system and the BEST support, Small enough to care.
10. Open, standards based architecture, non-proprietary as required in the i3 published standards
11. Record all NG9-1-1 communication (Audio, Video, Chat, Image, Telematics, VoIP) and P25 rad
12. 40+ year old stable company (past 30+ years providing Communication Recording Systems & support)



We would love to partner with your team but in the event, you decide not to partner with us, please make sure you do three things.

1. Get a letter from the recording *manufacturer*, not a reseller guaranteeing your system is NG9-1-1 ready, and will not require a fork lift upgrade. The last thing you want to do is buy twice! Typically, 911 boards, County Commissioners, and City Councilmen frown on that behavior
2. Get a letter from the manufacturer, again not a reseller, guaranteeing that the product you are buying will not be **SUNSET** (obsoleted) within the next 10 years.
3. Make sure you receive a written 100% money back guarantee!

We want you to be successful even if you decide not to partner with us.

Sincerely yours,

Mike Bragg
NG 9-1-1 Public Safety Specialist
Equature

Prepared by: Mike Bragg

Prepared for: Columbia County Combined Emergency Communications Center
Equature Public Safety Specialist
NG 9-1-1 Division Equature.com



Implementation Schedule: (Estimated Business Days)

<u>Milestone</u>	<u>Responsibility</u>
Day 1 - Purchase order received by EQUATURE.	Columbia County
Day 2 - Pre-installation checklist created	EQUATURE
Day 6 - Kickoff Meeting and acceptance of pre-installation responsibilities	EQUATURE/ Columbia
Day 7 - Sample Data Streams, interpretations and documentation are provided	Columbia County
Day 8 - All user and station data delivered to EQUATURE.	Columbia County
Day 8 - Data entry completed	EQUATURE
Day 10 - System burn-in and testing completed	EQUATURE
Day 10 - System assembly completed - unit shipped	EQUATURE
Day 12 - System delivered to Columbia County	EQUATURE/Columbia
Day 15 - Confirm Installation Date and Site Readiness	EQUATURE/ Columbia
Day 30 - Installation and testing begins	EQUATURE
Day 31-32 - On-site training begins	EQUATURE

Equature is committed to providing value to our Public Safety customers. Our goal is to establish a long-term, Win/Win partnership with the Columbia County Combined Emergency Communications Center. Our mission in providing this value, requires us to hire and retain top professionals. We have been fulfilling this mission for over 40 years.

SPECIAL PRICE QUOTATION

Columbia County Combined Emergency Communications Center

<u>QTY</u>	<u>DESCRIPTION</u>	<u>PRICE</u>
1	EQUATURE NG9-1-1 Communication Recording System	



40 Channels Voice and Data Platform (Analog and VoIP) GSA Pricing \$41,991.00

One Year Warranty, 24x7x365 (Hardware, Software, Parts, Labor & Travel)
Includes Shipping (GSA Contract # GS-35F-079DA)
Full Unlimited Site License:

Instant Recall, Multi-channel Scenario Reconstruction Playback, Live Monitor, Dashboard,
Visual Mapping of calls, Reporting, Redaction, Cropping, and Notes Package

Professional Services:

Installation, set-up and configuration	\$3,500.00	
Comprehensive Training - End User, Administrator and Technical	\$1,500.00	Included*
Total	\$45,491.00	

5 Yrs. Support (Warranty + 4 yrs.) Paid in Advance \$6,298.65 X 4yrs.) ~~-\$22,675.00~~ (savings of \$2,519.60)

	<u>Price</u>	<u>Partner</u>	<u>Annual Support</u>
Options: 100% Content Search – Spoken Word/Phrase Search	\$7,875.00	\$5,880.00	\$ 882.00/yr.
CAD Capture – Auto Populating CAD Fields	\$3,937.50	\$3,150.00	\$ 472.50/yr
Quality Assessment Grading	\$4,410.00	Included*	\$ N/C
Screen Recording for Answering Positions	\$1,890.00	Included*	\$ N/C
ANI/ALI	\$3,937.50	Included*	\$ N/C
Elite Performance Training – \$400 per dispatcher	\$11,200.00	Included*	\$ N/C
Pro QA Integration	\$3,150.00	Included*	\$ N/C

*Secure \$31,695.07 in value incentives, if decision to partner with us by July 31, 2017 (subject to board approval).

Terms:

One Hundred (100%) percent with receipt of equipment.

Customer Acceptance: _____ Date: _____

Print Name: _____ Title: _____
Email to Mike Bragg: mbragg@equature.com

100% Money Back Satisfaction Guarantee Pricing good until August 17, 2017

100% EQUATURE Money Back Satisfaction Guarantee

Equature is pleased to offer this Money Back Satisfaction Guarantee. As a manufacturer and developer of Next Generation 9-1-1 Communication Capture Solutions, we are in direct contact



with our customers and do not have to rely on the Reseller model of moving requests and concerns up the chain of command. You have a direct line to the top. We have over 20 years of experience in servicing the Public Safety community and understand the needs and challenges you face each day. We have a long track record of success which allows us to offer the following guarantee. In the event the EQUATURE® Recording system does not perform during the acceptance period to standard 911 recording features and functions then Columbia County Combined Emergency Communications Center can terminate the agreement with 90 days' notice to correct the issues and receive a full refund.

We look forward to creating a long-term Business Partnership!

Columbia County Combined Emergency Communications Center agrees to do business with Equature.

Agreed: _____

Printed Name: _____

Signature: _____

Date: _____

Equature: Mike Bragg – Industry Specialist

Date: _____

Equature Elite Performance Suite

World Class Continuous Training

Elite Continuous Training is a training platform designed to provide you with world class continuous training with compounding content each year. This is extremely beneficial as you will be able to provide



your Telecommunicators with a growing content core along with a continuous training methodology. Retail Price per dispatcher is \$500 per 16 hour course increment.

Elite Performance Year 1: (16 Hours)

1. Elite Core – 4-hour training includes:

Communication in the Dispatch Center
 Dispatcher Improvement – Fight, Flight, Freeze, Metabolic Syndrome, Mind Set
 Liability for the Communication Center
 Critical Incidents

2. Customer Service 8-hour course

Customer service skills for dispatchers is a critical class for all dispatchers and 9-1-1 personnel. Topics include: annoying and difficult callers, words to use for extraordinary customer service, how to defuse anger and officer/ dispatcher relations.

3. Becoming More Than Just a Dispatcher 1 –hour course

4. 911 Challenges 1-hour course

5. Dispatching Skills 1-hour course

6. First Responder Safety - 1-hour course

Elite Performance Year 2: (28 Hours)

1. Everything from year 1 (16 Hours)

2. How to Save a Life – Yours! 8-hour course

In this day and age heart disease, stroke and diabetes are not discriminatory however those that do not take care of themselves can find themselves in the front of the pack when it comes to SCA or CVA. Dispatchers for the most part live very unhealthy lives; we add unnecessary stress on ourselves and create our own negative environments. We eat unhealthy foods, drink unhealthy drinks, sit too long and put ourselves at risk for metabolic syndrome. The communications center is a breeding ground for many personality types and low morale. This class will share some life/health changing education and techniques to assist in the reduction of unnecessary medical issues, improve working relationship and improve morale.

3. Minimum of 4 additional Hours of updated content (4 webinars) = Minimum of 8 hours of total additional content

Elite Performance Year 3: (40 Hours)



1. **Everything from years 1 and 2 (28 hours)**
2. **Breeding Success 8-hour course**
This course is designed to assist in making the training program effective to produce a fully trained dispatcher. Topics include: How to breed failure, how to breed success, training on a budget, the learning process, roles of the trainer, reinforcement training, and much more.
3. **Minimum of 4 additional Hours of updated content (4 webinars) = Minimum of 12 hours of total additional content**

Elite Performance Year 4: (52 Hours)

1. **Everything from years 1, 2, 3 (40 hours)**
2. **Active Shooter 8-hour course**
An interactive class focusing on skills supervisors need. Topics covered include federal laws, supervisor skill and styles, problem solving, counseling and liability.
3. **Minimum of 4 additional Hours of updated content (4 webinars) = Minimum of 16 hours of total additional content**

Elite Performance Year 5: (64 Hours)

1. **Everything from years 1, 2, 3, 4 (52 hours)**
2. **Suicide Intervention 8-hour course**
This course educates public safety call takers in suicide crisis intervention. Topics include: suicide attitudes and facts, risk assessment of caller, risk assessment of responder, call taker interaction, and suicide call case studies review.
3. **Minimum of 4 additional Hours of updated content (4 webinars) = Minimum of 20 hours of total additional content**



11211 W. Tulsa Main Road, Bartlesville, OK
74603-1800 / 405-336-7471 / 800-441-5656

Customer Acceptance: _____ Date: _____

Print Name: _____ Title: _____

Please fax to Michael Bragg at (248) 569-5567

100% Money Back Satisfaction Guarantee

Pricing good until March 31, 2017

100% DSS Money Back Satisfaction Guarantee

DSS Corporation is pleased to offer this Money Back Satisfaction Guarantee. As a manufacturer and developer of Next Generation 9-1-1 Communication Capture Solutions, we are in direct contact with our customers and do not have to rely on the Reseller model of moving requests and concerns up the chain of command. You have a direct line to the top. We have over 20 years experience in servicing the Public Safety community and understand the needs and challenges you face each day. We have a long track record of success which allows us to offer the following guarantee. In the event the DSS Equature® Recording system does not perform during the acceptance period to standard 911 recording features and functions then Columbia County Sheriff's Office can terminate the agreement with 90 days' notice to correct the issues and receive a full refund.

We look forward to creating a long-term Business Partnership!

Columbia County Sheriff's Office agrees to do business with DSS Corporation.

Agreed: _____

Printed Name: _____

Signature: _____

Date: _____

DSS Corporation: Michael Bragg – Industry Specialist

Robert Hines – Director of Sales

Date: _____

DSS Corporation

Expect Excellence

Contract Number: **GS-35F-079DA**

DICTATION SALES & SERVICE CORPORATION **DSS CORPORATION**

18311 W. TEN MILE ROAD

SOUTHFIELD, MI 48075

www.dispatchimprovement.com

FAX: 248-569-6567

Office: 248-569-6440

AUTHORIZED
INFORMATION TECHNOLOGY SCHEDULE PRICELIST
GENERAL PURPOSE COMMERCIAL INFORMATION TECHNOLOGY
EQUIPMENT, SOFTWARE AND SERVICES

DSS Corporation designs and manufactures communication logging systems for Public Safety, First Responders and Contact Centers. DSS provides Next Generation 911 (NG9-1-1) Event Logging and Media Capture in addition to speech analytics, screen capture and Learning on Demand Dispatch Improvement courses.

DSS provides the following SIN items:

- Special Item No. 132-8 Purchase of New Equipment
- Special Item No. 132-12 Equipment Maintenance
- Special Item No. 132-33 Perpetual Software Licenses
- Special Item No. 132-50 Training Courses

DSS Corporation – 18311 W. 10 Mile Rd., Southfield, MI 48075



Description	Qty	GSA Retail	GSA
Voice Licenses	41	\$297.91	\$12,214.31
VoIP Licenses	9	\$466.38	\$4,197.42
24 Port analog card	2	\$4,247.05	\$8,494.10
4U Server	1	\$5,311.03	\$5,311.03
ANI/ALI	1	\$2,792.95	\$2,792.95
Screens	4	\$223.44	\$893.76
QA	28	\$111.72	\$3,128.16
Aqua / ProQA license per client install	1	\$4,734.27	\$4,734.27
Shipping	1	\$225.00	\$225.00
Installation*	2	\$1,750.00	\$3,500.00
			\$45,491.00



WORD SYSTEMS, INC.

LEADER IN VOICE AND DATA RECORDING SOLUTIONS



Digital Voice Logging System

Prepared For: Columbia County 911
 Prepared By: Joe Pelman 800-425-7637 x1127

Date: 3/31/2017

50 Channel NRR with Inform Professional Software, Evaluation Module and AQUA Integration

QTY	DESCRIPTION	PART #	UNIT PRICE	EXTENDED
1	Nice Recording Express Standard Features include: Enhanced Security Features E-mail/SNMP based Alarms Custom Database Fields-CORE API Drivers NTP Support 256-Bit Encryption-Advanced Storage Compression	NIL IAD6 Fingerprinting Rules-based Archiving & Backup Network Based Archiving Support Personalized Views & Statistical Reporting Package		
Nice Inform Professional				
1	Inform Professional Software Package including one NICE Recording Core Server, MySQL license and NICE Inform Lite Server license	RA-PS-INFRM-PROF-CL	\$1,000.00	\$1,000.00
50	One (1) Audio Recording license, including Inform Professional application support, CDR integration and ANIVALL	RA-PS-INFRM-PROF-1CH	\$550.00	\$27,500.00
4	NICE Inform Professional Reconstruction concurrent user license. Includes Redaction	RA-PS-INFRM-PROF-RCOIN-1CC	\$1,750.00	\$7,000.00
1	NICE Inform Professional Organizer one concurrent user license	RA-PS-INFRM-PROF-ORG-1CC	\$3,500.00	\$3,500.00
2	NICE Inform Professional Monitor and Record Call Replay module concurrent user	RA-PS-INFRM-PROF-MONRCR-1CC	\$1,200.00	\$2,400.00
9	NICE Inform Professional Verify concurrent user license	RA-PS-INFRM-PROF-VER-1CC	\$300.00	\$2,700.00
3	NICE Inform Evaluator application one concurrent user license	RA-PS-INFRM-PROF-EVAL-1CC	\$1,000.00	\$3,000.00
26	NICE Inform Evaluator named evaluator/Public Safety Operator	RA-PS-INFRM-PROF-PS-OPERATOR	\$100.00	\$2,800.00
3	NICE Inform Reporter one concurrent license	RA-PS-INFRM-PROF-REP-1CC	\$500.00	\$1,500.00
9	NICE Inform Professional User Registration Application concurrent user license	RA-PS-INFRM-PROF-URA-1CC	\$25.00	\$225.00
9	1 Workstation Concurrent Software Screen Recording license, including Inform Professional application support	RA-PS-INFRM-PROF-SWSCREEN-1CH	\$500.00	\$4,500.00
1	NICE Inform API for integration with AQUA - per single concurrent user connection	RA-PS-INFRM-PROF-AQUA-API	\$1,000.00	\$1,000.00
Capture Boards				
2	Analog board package for up to 24 channels (full length PCIe slot required)	RA-PS-4NR-ANALOGBT-FULL	\$2,000.00	\$4,000.00
1	Contact Closure Board for up to 96CH, 24 Terminals	RA-PS-4NR-CTC	\$1,075.00	\$1,075.00
Total quantity of each three items must equal total of 1CH Audio Recording license quantities ordered				
41	Configuration of 1 NICE Recording audio channel to Analog +	RA-PRM-PS-INFRM-ANALOGBT-CONFIG1C	\$0.00	\$0.00
9	Configuration of 1 NICE Recording audio channel to VoIP	RA-PRM-PS-INFRM-VOIP-CONFIG-1CH	\$0.00	\$0.00
1	Configuration - MySQL License Delivery (Qty 1 Required each logger)	RA-PRM-PS-INFRM-MYSQL	\$0.00	\$0.00
Nice Software Assurance				
1	Nice Software Assurance First Year (Required)	RA-PS-MAIN-NICE-IND-STD		\$4,354.00
ADDITIONAL HARDWARE / SOFTWARE				
1	HP Tower/LL Server (2x500GB RAID1, Redundant PS, MS SVR STD 2012 R2) (Up to 56 channels of TDM or 100 VoIP channels w/ Essential logger OR may be used as Inform Pro server only)	HP-ML30G9	\$4,695.00	\$4,695.00
1	External USB Systems Image Drive (Include one with each server)	WSK-SYSIMAGE	\$0.00	\$0.00
1	Keyboard, 19" Flat Screen Monitor, Keyboard and Mouse	NKM19LCD	\$425.00	\$425.00
1	Computer Speakers	COMPSPKRS	\$20.00	\$20.00
ACCESSORIES / SUPPLIES				
1	HP Tower to Rack Convi Tray Universal Kit (for HP ML110, HP ML310 G9, HP ML30 G9)	HP-417705B21	\$425.00	\$425.00
			Sub-Total	\$72,419.00
PROFESSIONAL SERVICES				
1	Installation and training	INVT		\$5,340.00
1	Remote installation/configuration of AQUA integration to NICE Inform API per single concurrent user connection (PS-INFRM-PROF-AQUA-API)	RA-PS-IN-ASC40-PS	\$1,000.00	\$1,000.00
1	Promotional Discount		\$13,513.00	(\$13,513.00)
			Order Total	\$68,146.00
TERMS AND CONDITIONS				
A	Please see Exhibit A for sample Statement of Work - To be reviewed at Pre-Installation meeting.			
B	Please see Exhibit B for Technical Services Agreement.			
C	Optional Customer Provided Capture PC/Server Minimum specs on Exhibit C .			
D	DELIVERY: Please allow estimated 30-60 days from date of written purchase order (or date of first payment when applicable) for delivery.			
E	Warranty on the equipment will start after installation is complete, or 90 days after acknowledgment from customer to order equipment and/or license via 50% deposit or special request, whichever is earliest.			
F	Custom equipment orders may not be returned. Stock merchandise and accessories may be returned if in the original packaging provided a restocking fee of not less than twenty-five percent (25%) or such greater restocking fee as determined by WSI's supplier is paid by customer.			
G	This quote does not include State and Local taxes. Customer to provide tax exempt certificate or taxes will be added to the invoice.			
H	Payment terms: 50% with order, 50% upon system installation.			
I	This price list together with all of its Exhibit and license terms and conditions from the software manufacturer, which are hereby incorporated by reference, constitutes the entire agreement with respect to its subject matter. No inconsistent or additional terms submitted by Customer in any purchase order or similar document will be binding on WSI.			
J	Please mail purchase orders to Word Systems, 9225 Harrison Park Court Indianapolis, IN 46216 or FAX-317-544-2132			
K	QUOTATION IS VALID FOR 90 DAYS			
Approved By		POS		
Title		Date		



WORD SYSTEMS, INC.

LEADERS IN VOICE AND DATA RECORDING SOLUTIONS



Digital Voice Logging System

Date: 3/31/2017

Prepared For: Columbia County 911 (Back Up Site)

Prepared By: Joe Palmer 800-425-7837

38 Channel NRX Solution with Inform Essential Software

QTY	DESCRIPTION	PART #	UNIT PRICE	EXTENDED
1	Nice Recording eXpress Standard Features Include: Enhanced Security Features E-mail/SNMP based Alarms Custom Database Fields-CORE API Drivers NTP Support 256-Bit Encryption-Advanced Storage Compression	NIL MD5 Fingerprinting Rules-based Archiving & Backup Network Based Archiving Support Personalized Views & Statistical Reporting Package		
Nice Inform Essential				
1	Inform Essential Software Package Inc. 1 NICE Recording Core Server, MySQL lic and NICE Inform Lite Server license	RA-PS-INFRM-ESNT-CL	\$500.00	\$500.00
36	One (1) Audio Recording license, including Inform Essential application support	RA-PS-INFRM-ESNT-1CH	\$425.00	\$15,300.00
1	NICE Inform Essential Reconstruction concurrent user license	RA-PS-INFRM-ESNT-RCON-1CC	\$1,000.00	\$1,000.00
1	Audio Redaction capability within NICE Inform Essential/Lite Reconstruction application, per concurrent user license	RA-PS-INFRM-ESNT-RCON-REDACT-1CC	\$500.00	\$500.00
4	NICE Inform Essential Verify concurrent user license	RA-PS-INFRM-ESNT-VER-1CC	\$300.00	\$1,200.00
4	ANI-AJI Annotator license for 1 channel for Essentials, Per recorded Call Taker position	RA-PS-INFRM-ESNT-ANALI-1CH	\$25.00	\$100.00
Capture Boards				
1	Analog board package for up to 8 channels (short length PCIe slot required)	RA-PS-NR-ANALOGBT-SHORT	\$1,250.00	\$1,250.00
1	Analog board package for up to 24 channels (full length PCIe slot required)	RA-PS-NR-ANALOGBT-FULL	\$2,000.00	\$2,000.00
1	Contact Closure Board for Up to 86CH, 24 Terminals	RA-PS-NR-CTC	\$1,075.00	\$1,075.00
Total quantity of next three items must equal total of 1CH Audio Recording license quantities ordered				
32	Configuration of 1 NICE Recording audio channel to Analog +	RA-PRM-PS-INFRM-ANALOGBT-CONFIG1C	\$0.00	\$0.00
4	Configuration of 1 NICE Recording audio channel to VoIP	RA-PRM-PS-INFRM-VOIP-CONFIG-1CH	\$0.00	\$0.00
1	Configuration - MySQL License Delivery (Qty = Required each logger)	RA-PRM-PS-INFRM-MYSQL	\$0.00	\$0.00
Nice Software Assurance				
1	Nice Software Assurance First Year (Required)	RA-PS-MAIN-NICE-IND-STD		\$1,805.00
ADDITIONAL HARDWARE / SOFTWARE				
1	HP Tower4U Server (2x500GB RAID1, Redundant PS, MS SVR STD 2012 R2) (Up to 56 channels of TDM or 100 VoIP channels as Essential logger OR may be used as Inform Pro server only)	HP-ML30G9	\$4,895.00	\$4,895.00
1	External USB Systems Image Drive (Include one with each server)	WSI-SYSIMAGE	\$0.00	\$0.00
1	Keyboard, 18" Flat Screen Monitor, Keyboard and Mouse	MKM19LCD	\$425.00	\$425.00
1	Computer Speakers	COMPSPKRS	\$20.00	\$20.00
ACCESSORIES / SUPPLIES				
1	HP Tower to Rack Conv Tray Universal Kit (for HP ML110, HP ML310 G9, HP ML30 G9)	HP-417705821	\$425.00	\$425.00
			Sub-Total	\$30,395.00
PROFESSIONAL SERVICES				
Installation and training			INST	\$3,620.00
1	Discount		-\$5,758.00	(\$5,758.00)
			Order Total	\$28,257.00

TERMS AND CONDITIONS

- A Please see Exhibit A for sample Statement of Work -To be reviewed at Pre-Installation meeting.
- B Please see Exhibit B for Technical Services Agreement.
- C Optional Customer Provided Capture PC/Server Minimum specs on Exhibit C.
- D DELIVERY: Please allow estimated 30-60 days from date of written purchase order (or date of first payment when applicable) for delivery.
- E Warranty on the equipment will start after installation is complete, or 90 days after acknowledgement from customer to order equipment and/or licenses via 50% deposit or special request, whichever is earliest.
- F Custom equipment orders may not be returned. Stock merchandise and accessories may be returned if in the original packaging provided a restocking fee of not less than twenty-five percent (25%) or such greater restocking fee as determined by WSI's supplier is paid by customer.
- G This quote does not include State and Local taxes. Customer to provide tax exempt certificate or taxes will be added to the invoice.
- H Payment terms; 50% with order, 50% upon system installation.
- I This price list together with all of its Exhibit and license terms and conditions from the software manufacturer, which are hereby incorporated by reference, constitutes the entire agreement with respect to its subject matter. No inconsistent or additional terms submitted by Customer in any purchase order or similar document will be binding on WSI.
- J Please mail purchase orders to Word Systems, 2925 Harrison Park Court Indianapolis, IN 46216 or FAX-317-644-2192
- K QUOTATION IS VALID FOR 90 DAYS

Approved By

PO#

Title

Date



VPI Empower 911



Presentation Date: 03/28/2017
Valid Until Date: 06/26/2017

Quote #: 001614
Rev: 03/28/2017 01:09 PM

Prepared For:

Company: Columbia County Combined Communications
Contact: Thomas Brazil
Install Address: 263 NW Lake City Ave
Lake City, FL 32055
Phone: (386) 758-1388
Email: tbrazil@columbiacountyfla.com

Prepared By:

Company: Replay Systems
Contact: Ryan Hurley
Address: 6555 NW 9th Ave, Ste 105
Fort Lauderdale, FL 33309
Toll-Free: (800) 722-3472
Phone: (954) 821-6870
Email: ryan.hurley@replaysystems.com

OF CHANNELS: 50

OF POSITIONS:

NOTES: 50 Channel VPI Voice Recording System for Columbia County Primary PSAP. 9 Cisco IP, 8 analog trunks, 13 analog admin, 11 analog radio, 9 '911' positions. VPI's QA/Coaching/Screen Capture Bundle for the 9 Positions. CAD & Priority Dispatch Integration. DELL Recording Server. On-site install and training.

Software				
Quantity	Part Number	Description	List Price	Total Price
1	VP5-VP-100-S	V-Portal Suite system license. Sized to support systems up to 100 seats or recording channels.	\$2,150.00	\$2,150.00
50	VP5-CVRE	VPI CAPTURE ESSENTIAL: Voice Recording License. Per Activated Channel. Up to 100 channels	\$360.00	\$18,000.00
9	VP5-Q-PSAP	VPI QUALITY PRO PSAP bundle. Per Dispatch / Call taker position. Includes screen recording, smart evaluation form and coaching. (Requires Item VP5-PSAP)	\$788.00	\$7,092.00
1	VP5-PSAP-2-100	PSAP enhanced bundle: Instant Recall, Live Monitor, Caller ID (if available), Incident Creation & Redaction Tool. Includes I ANI / ALL data collector. Sized for up to 100 call takers.	\$1,875.00	\$1,875.00
1	VP5-PD	VPI's Priority Dispatch AQUA Integration. Requires AQUA 6.x or higher	\$4,200.00	\$4,200.00
1	VP5-CAD-DC-100	CAD data collector for capturing events or meta data for up to 100 channel recording system. Leverages VPI's API, URL Monitoring or database connectors	\$2,678.00	\$2,678.00
			Subtotal:	\$35,995.00

Hardware				
Quantity	Part Number	Description	List Price	Total Price
1	RPL-SVR-4URM001-10-AIO	4U Rack Mount - All in One: Intel Xeon Quad Core 2.5Ghz CPU, 16GB Ram DDR3-12800, Hot swap 500GB 7200 RPM RAID 1 x 2. 3 PCI-E Slots. Windows Server 2012 STND R2 64 Bit, Redundant 920w hot swap power, 1 DVD/RAM multi-drive. 3 PCI Synway, 2 PCI AudioCodes.	\$6,000.00	\$6,000.00
2	RPL-Analog-24	24 Port Analog Interface Card	\$5,052.00	\$10,104.00
2	RPL-Cable15	15FT 25-Pair Cable (NON-DISCOUNTABLE)	\$73.00	\$146.00
			Subtotal:	\$16,250.00

Services				
Quantity	Part Number	Description	List Price	Total Price
3	RPL-INSTALL-ONSITE/REMOTE	Replay Systems onsite/remote installation services per day plus travel expenses, if applicable (1 Day Only)	\$1,800.00	\$5,400.00
			Subtotal:	\$5,400.00



VPI Empower 911



Presentation Date: 03/28/2017
Valid Until Date: 06/26/2017

Quote #: 001614
Rev: 03/28/2017 01:09 PM

Subtotal (including additional services):	\$57,645.00
Installation Fee:	\$0.00
Tradein:	\$7,500.00
Grand Total:	\$50,145.00

Replay's Prepaid Performance Plans: Please check the plan you would like to purchase (optional).

- \$20,378 Prepaid Year 2-3 Assured Performance Plan (Includes warranty plus 2 years of maintenance)
- \$30,567 Prepaid Year 2-4 Assured Performance Plan (includes warranty plus 3 years of maintenance)
- \$40,756 Prepaid Year 2-5 Assured Performance Plan (includes warranty plus 4 years of maintenance)

GOLD SERVICE LEVEL: 24/7 phone support, parts, onsite M-F 8am-5pm service. Amount quoted for budgetary purposes. May be added to total at customer's discretion.

I would not like to purchase an extended maintenance plan.

Payment Terms: Net 30 upon delivery

Customer Signature: _____

Print Name: _____ Title _____

Date: _____

PO Number: _____

Unless otherwise agreed, Payment Terms are NET 30 upon delivery.

Please read the attached "Installation Assumptions". These conditions apply to any purchase.
Prepaid Performance Plans include one year of warranty plus two, three, or four additional years of prepaid support respectively.



Presentation Date: 03/28/2017
Valid Until Date: 06/26/2017

Quote #: 001614
Rev: 03/28/2017 01:09 PM

Replay Systems

The following assumptions were made in generating your installation & configuration pricing:

1. Customer is responsible for all data network infrastructure not purchased from Replay including switches, hubs, bridges, routers, external caching devices and cabling.
2. Customer is to provide prior to installation:
 - a. An accurate and complete document containing channel and/or position mappings for channel name, extension number, agent login, channel type (phone or radio), workstation IP address, computer name, and operating system. For VOIP systems: Complete list of all IP addresses and MAC addresses of all devices to be recorded. Setup of the SPAN port and any configuration to VoIP call manager is also responsibility of the customer.
 - b. LAN/WAN that supports TCP/IP protocol with static IP addresses for each recording appliance and server.
 - c. Sufficient space for the units and/or cabinets as well as sufficient entryway clearance for all system components. Temperatures are not to exceed 75 degrees in equipment room.
 - d. Sufficient power to the purchased recording system (including cabling and outlets) and UPS unless ordered with the system. Systems with two power supplies should be on two separate circuits.
 - e. A demarcation point, to include all required PBX, Radio and Network signals and associated hardware, to an easily accessible point within 15 feet of system. The Customer will clearly identify all cables with information indicating signal source and/or network connection and confirm they are fully operational.
 - f. A person to act as Project Manager to assist with the implementation and acceptance of the system above. Also must have administrator login credentials to load applications on desktops and to add recorder to domain, if required.
 - g. Customer agrees to allow remote system access via customer provided VPN, or our remote access software application for remote system diagnostics.
 - h. Any and all servers and workstations required but not ordered above.
 - i. Sufficient facilities to conduct all required training.
3. Replay is NOT responsible for any aspect of Union or other labor negotiations, procurement, contracting, use or payment.
4. Hours for implementation (and training) will be 8:00AM - 5:00PM Local Time Monday through Friday, excluding Replay and Customer holidays.
5. Unless otherwise noted above, standard installation covers the loading of workstation software on up to 4 customer supplied PCs. Additional PC installs will be completed under Time and Materials charges, minimum \$150 per PC, unless agreed upon prior to installation.
6. Additional system's components if required, such as Beep tone generators, D to A converters, etc. will be invoiced separately.
7. With regard to Digital phone systems, it is assumed that all phones are two wire unless otherwise specified. Four wire phones will require double channel count for recording and purchase of additional hardware and licenses.
8. Caller ID is only captured if available from the customer's phone system, as connected.
9. Replay resolves to work toward giving your Equipment availability approaching 100%. To do this, Replay will require remote access to the recorder, but always with prior knowledge, approval, and cooperation of Purchaser. If remote access is not permitted additional charges for warranty service will apply.
10. Unless otherwise agreed between both parties, warranty begins upon determination that all system channels are successfully recording and can be accessed through the recorder server or a network-connected workstation.
11. The system warranty will begin 10 days after delivery, unless otherwise agreed to by both parties.
12. Should installation be delayed more than 30 days at the customer's request, customer agrees to pay Replay the full amount of the invoice net 10 days after delivery.
13. Replay Systems sign off sheet reflects physical installation, network connectivity and recording of channels. Any additional configuration changes or additions outside the original SOW should not delay installation, acceptance.



VPI Empower 911



Presentation Date: 03/24/2017
Valid Until Date: 06/22/2017

Quote #: 001615
Rev: 03/28/2017 01:18 PM

Prepared For:

Company: Columbia County Combined Communications
Contact: Thomas Brazil
Install Address: 263 NW Lake City Ave
Lake City, FL 32055
Phone: (386) 758-1388
Email: tbrazil@columbiacountyfla.com

Prepared By:

Company: Replay Systems
Contact: Ryan Hurley
Address: 6555 NW 9th Ave, Ste 105
Fort Lauderdale, FL 33309
Toll-Free: (800) 722-3472
Phone: (954) 821-6870
Email: ryan.hurley@replaysystems.com

OF CHANNELS: 46

OF POSITIONS:

NOTES: Columbia County Backup PSAP. VPI Voice Recording System- 46 channels.

Software				
Quantity	Part Number	Description	List Price	Total Price
1	VPS-VP-100-S	V-Portal Suite system license. Sized to support systems up to 100 seats or recording channels.	\$2,150.00	\$2,150.00
46	VPS-CVR-Redundant	VPI CAPTURE REDUNDANT: Voice Recording License for redundant capture purposes only, per applicable terms. Per activated channel.	\$171.00	\$7,695.00
			Subtotal:	\$9,845.00

Hardware				
Quantity	Part Number	Description	List Price	Total Price
1	RPL-SVR-MIDTWR005-AIO	Mid Tower/500W 80Plus High Efficiency Power Supply All in One: Intel i3 3.4 GHz, 8 GB RAM, 500 GB Raid 1 x 2, 5 PCIe Slots, Windows Server 2012 STND R2 64 Bit, 1 DVD/Ram multi-drive, (Note: Hot swap power and Hot swap drives not available on this model)	\$4,750.00	\$4,750.00
2	RPL-Analog-24	24 Port Analog Interface Card	\$5,052.00	\$10,104.00
2	RPL-Cable15	15FT 25-Pair Cable (NON-DISCOUNTABLE)	\$73.00	\$146.00
			Subtotal:	\$15,000.00

Services				
Quantity	Part Number	Description	List Price	Total Price
1	RPL-INSTALL-ONSITE/REMOTE	Replay Systems onsite/remote installation services per day plus travel expenses, if applicable (1 Day Only)	\$1,800.00	\$1,800.00
			Subtotal:	\$1,800.00

Subtotal (including additional services):	\$26,645.00
Installation Fee:	\$0.00
Tradein:	\$1,750.00
Grand Total:	\$24,895.00



VPI Empower 911



Presentation Date: 03/24/2017
Valid Until Date: 06/22/2017

Quote #: 001615
Rev: 03/28/2017 01:18 PM

Replay's Prepaid Performance Plans: Please check the plan you would like to purchase (optional).

- \$5,723 Prepaid Year 2-3 Assured Performance Plan (includes warranty plus 2 years of maintenance)
- \$8,584 Prepaid Year 2-4 Assured Performance Plan (includes warranty plus 3 years of maintenance)
- \$11,446 Prepaid Year 2-5 Assured Performance Plan (includes warranty plus 4 years of maintenance)

BRONZE SERVICE LEVEL: 24/7 phone support & fixes and enhancements within version. Amount quoted for budgetary purposes. May be added to total at customer's discretion.

- I would not like to purchase an extended maintenance plan.

Payment Terms: Net 30 upon delivery

Customer Signature: _____
Print Name: _____ Title: _____
Date: _____
PO Number: _____

Unless otherwise agreed, Payment Terms are NET 30 upon delivery.

Please read the attached "Installation Assumptions". These conditions apply to any purchase.

Prepaid Performance Plans include one year of warranty plus two, three, or four additional years of prepaid support respectively.



VPI Empower 911



Presentation Date: 03/24/2017

Valid Until Date: 06/22/2017

Quote #: 001615

Rev: 03/28/2017 01:18 PM

Replay Systems

The following assumptions were made in generating your installation & configuration pricing:

1. Customer is responsible for all data network infrastructure not purchased from Replay including switches, hubs, bridges, routers, external caching devices and cabling.
2. Customer is to provide prior to installation:
 - a. An accurate and complete document containing channel and/or position mappings for channel name, extension number, agent login, channel type (phone or radio), workstation IP address, computer name, and operating system. For VOIP systems: Complete list of all IP addresses and MAC addresses of all devices to be recorded. Setup of the SPAN port and any configuration to VoIP call manager is also responsibility of the customer.
 - b. LAN/WAN that supports TCP/IP protocol with static IP addresses for each recording appliance and server.
 - c. Sufficient space for the units and/or cabinets as well as sufficient entryway clearance for all system components. Temperatures are not to exceed 75 degrees in equipment room.
 - d. Sufficient power to the purchased recording system (including cabling and outlets) and UPS unless ordered with the system. Systems with two power supplies should be on two separate circuits.
 - e. A demarcation point, to include all required PBX, Radio and Network signals and associated hardware, to an easily accessible point within 15 feet of system. The Customer will clearly identify all cables with information indicating signal source and/or network connection and confirm they are fully operational.
 - f. A person to act as Project Manager to assist with the implementation and acceptance of the system above. Also must have administrator login credentials to load applications on desktops and to add recorder to domain, if required.
 - g. Customer agrees to allow remote system access via customer provided VPN, or our remote access software application for remote system diagnostics.
 - h. Any and all servers and workstations required but not ordered above.
 - i. Sufficient facilities to conduct all required training.
3. Replay is NOT responsible for any aspect of Union or other labor negotiations, procurement, contracting, use or payment.
4. Hours for implementation (and training) will be 8:00AM - 5:00PM Local Time Monday through Friday, excluding Replay and Customer holidays.
5. Unless otherwise noted above, standard installation covers the loading of workstation software on up to 4 customer supplied PCs. Additional PC installs will be completed under Time and Materials charges, minimum \$150 per PC, unless agreed upon prior to installation.
6. Additional system's components if required, such as Beep tone generators, D to A converters, etc. will be invoiced separately.
7. With regard to Digital phone systems, it is assumed that all phones are two wire unless otherwise specified. Four wire phones will require double channel count for recording and purchase of additional hardware and licenses.
8. Caller ID is only captured if available from the customer's phone system, as connected.
9. Replay resolves to work toward giving your Equipment availability approaching 100%. To do this, Replay will require remote access to the recorder, but always with prior knowledge, approval, and cooperation of Purchaser. If remote access is not permitted additional charges for warranty service will apply.
10. Unless otherwise agreed between both parties, warranty begins upon determination that all system channels are successfully recording and can be accessed through the recorder server or a network-connected workstation.
11. The system warranty will begin 10 days after delivery, unless otherwise agreed to by both parties.
12. Should installation be delayed more than 30 days at the customer's request, customer agrees to pay Replay the full amount of the invoice net 10 days after delivery.
13. Replay Systems sign off sheet reflects physical installation, network connectivity and recording of channels. Any additional configuration changes or additions outside the original SOW should not delay installation, acceptance.



VPI Empower 911



Presentation Date: 03/28/2017

Valid Until Date: 06/26/2017

Quote #: 001614

Rev: 03/28/2017 01:09 PM

Prepared For:

Company: Columbia County Combined Communications
Contact: Thomas Brazil
Install Address: 263 NW Lake City Ave
Lake City, FL 32055
Phone: (386) 758-1388
Email: tbrazil@columbiacountyfla.com

Prepared By:

Company: Replay Systems
Contact: Ryan Hurley
Address: 6555 NW 9th Ave, Ste 105
Fort Lauderdale, FL 33309
Toll-Free: (800) 722-3472
Phone: (954) 821-6870
Email: ryan.hurley@replaysystems.com

OF CHANNELS: 50

OF POSITIONS:

NOTES: 50 Channel VPI Voice Recording System for Columbia County Primary PSAP. 9 Cisco IP, 8 analog trunks, 13 analog admin, 11 analog radio, 9 '911' positions. VPI's QA/Coaching/Screen Capture Bundle for the 9 Positions. CAD & Priority Dispatch Integration. DELL Recording Server. On-site install and training.

Software				
Quantity	Part Number	Description	List Price	Total Price
1	VP5-VP-100-S	V-Portal Suite system license. Sized to support systems up to 100 seats or recording channels.	\$2,150.00	\$2,150.00
50	VP5-CVRE	VPI CAPTURE ESSENTIAL: Voice Recording License. Per Activated Channel. Up to 100 channels	\$360.00	\$18,000.00
9	VP5-Q-PSAP	VPI QUALITY PRO PSAP bundle. Per Dispatch / Call taker position. Includes screen recording, smart evaluation form and coaching. (Requires Item VP5-PSAP)	\$788.00	\$7,092.00
1	VP5-PSAP-2-100	PSAP enhanced bundle: Instant Recall, Live Monitor, Caller ID (if available), Incident Creation & Redaction Tool. Includes 1 ANI / ALL data collector. Sized for up to 100 call takers.	\$1,875.00	\$1,875.00
1	VP5-PD	VPI's Priority Dispatch AQUA integration. Requires AQUA 6.x or higher	\$4,200.00	\$4,200.00
1	VP5-CAD-DC-100	CAD data collector for capturing events or meta data for up to 100 channel recording system. Leverages VPI's API, URL Monitoring or database connectors	\$2,678.00	\$2,678.00
			Subtotal:	\$35,995.00

Hardware				
Quantity	Part Number	Description	List Price	Total Price
1	RPL-SVR-4URM001-10-AIO	4U Rack Mount - All in One: Intel Xeon Quad Core 2.5Ghz CPU, 16GB Ram DDR3-12800, Hot swap 500GB 7200 RPM RAID 1 x 2. 3 PCI-E Slots. Windows Server 2012 STND R2 64 Bit, Redundant 920w hot swap power, 1 DVD/RAM multi-drive, 3 PCI Synway, 2 PCI AudioCodes.	\$6,000.00	\$6,000.00
2	RPL-Analog-24	24 Port Analog Interface Card	\$5,052.00	\$10,104.00
2	RPL-Cable15	15FT 25-Pair Cable (NON-DISCOUNTABLE)	\$73.00	\$146.00
			Subtotal:	\$16,250.00

Services				
Quantity	Part Number	Description	List Price	Total Price
3	RPL-INSTALL-ONSITE/REMOTE	Replay Systems onsite/remote installation services per day plus travel expenses, if applicable (1 Day Only)	\$1,800.00	\$5,400.00
			Subtotal:	\$5,400.00



VPI Empower 911



Presentation Date: 03/28/2017
Valid Until Date: 06/26/2017

Quote #: 001614
Rev: 03/28/2017 01:09 PM

Subtotal (including additional services):	\$57,645.00
Installation Fee:	\$0.00
TradeIn:	\$7,500.00
Grand Total:	\$50,145.00

Replay's Prepaid Performance Plans: Please check the plan you would like to purchase (optional).

- \$20,378 Prepaid Year 2-3 Assured Performance Plan (includes warranty plus 2 years of maintenance)
- \$30,567 Prepaid Year 2-4 Assured Performance Plan (includes warranty plus 3 years of maintenance)
- \$40,756 Prepaid Year 2-5 Assured Performance Plan (includes warranty plus 4 years of maintenance)

GOLD SERVICE LEVEL: 24/7 phone support, parts, onsite M-F 8am-5pm service. Amount quoted for budgetary purposes. May be added to total at customer's discretion.

I would not like to purchase an extended maintenance plan.

Payment Terms: Net 30 upon delivery

Customer Signature: _____

Print Name: _____ Title _____

Date: _____

PO Number: _____

Unless otherwise agreed, Payment Terms are NET 30 upon delivery.

Please read the attached "Installation Assumptions". These conditions apply to any purchase.
Prepaid Performance Plans include one year of warranty plus two, three, or four additional years of prepaid support respectively.



Presentation Date: 03/28/2017

Valid Until Date: 06/26/2017

Quote #: 001614

Rev: 03/28/2017 01:09 PM

Installation & Configuration Replay Systems

The following assumptions were made in generating your installation & configuration pricing:

1. Customer is responsible for all data network infrastructure not purchased from Replay including switches, hubs, bridges, routers, external caching devices and cabling.
2. Customer is to provide prior to installation:
 - a. An accurate and complete document containing channel and/or position mappings for channel name, extension number, agent login, channel type (phone or radio), workstation IP address, computer name, and operating system. For VOIP systems: Complete list of all IP addresses and MAC addresses of all devices to be recorded. Setup of the SPAN port and any configuration to VoIP call manager is also responsibility of the customer.
 - b. LAN/WAN that supports TCP/IP protocol with static IP addresses for each recording appliance and server.
 - c. Sufficient space for the units and/or cabinets as well as sufficient entryway clearance for all system components. Temperatures are not to exceed 75 degrees in equipment room.
 - d. Sufficient power to the purchased recording system (including cabling and outlets) and UPS unless ordered with the system. Systems with two power supplies should be on two separate circuits.
 - e. A demarcation point, to include all required PBX, Radio and Network signals and associated hardware, to an easily accessible point within 15 feet of system. The Customer will clearly identify all cables with information indicating signal source and/or network connection and confirm they are fully operational.
 - f. A person to act as Project Manager to assist with the implementation and acceptance of the system above. Also must have administrator login credentials to load applications on desktops and to add recorder to domain, if required.
 - g. Customer agrees to allow remote system access via customer provided VPN, or our remote access software application for remote system diagnostics.
 - h. Any and all servers and workstations required but not ordered above.
 - i. Sufficient facilities to conduct all required training.
3. Replay is NOT responsible for any aspect of Union or other labor negotiations, procurement, contracting, use or payment.
4. Hours for implementation (and training) will be 8:00AM - 5:00PM Local Time Monday through Friday, excluding Replay and Customer holidays.
5. Unless otherwise noted above, standard installation covers the loading of workstation software on up to 4 customer supplied PCs. Additional PC installs will be completed under Time and Materials charges, minimum \$150 per PC, unless agreed upon prior to installation.
6. Additional system's components if required, such as Beep tone generators, D to A converters, etc. will be invoiced separately.
7. With regard to Digital phone systems, it is assumed that all phones are two wire unless otherwise specified. Four wire phones will require double channel count for recording and purchase of additional hardware and licenses.
8. Caller ID is only captured if available from the customer's phone system, as connected.
9. Replay resolves to work toward giving your Equipment availability approaching 100%. To do this, Replay will require remote access to the recorder, but always with prior knowledge, approval, and cooperation of Purchaser. If remote access is not permitted additional charges for warranty service will apply.
10. Unless otherwise agreed between both parties, warranty begins upon determination that all system channels are successfully recording and can be accessed through the recorder server or a network-connected workstation.
11. The system warranty will begin 10 days after delivery, unless otherwise agreed to by both parties.
12. Should installation be delayed more than 30 days at the customer's request, customer agrees to pay Replay the full amount of the Invoice net 10 days after delivery.
13. Replay Systems sign off sheet reflects physical installation, network connectivity and recording of channels. Any additional configuration changes or additions outside the original SOW should not delay installation, acceptance.



VPI Empower 911



Presentation Date: 03/24/2017

Valid Until Date: 06/22/2017

Quote #: 001615

Rev: 03/28/2017 01:18 PM

Prepared For:

Company: Columbia County Combined Communications
Contact: Thomas Brazil
Install Address: 263 NW Lake City Ave
Lake City, FL 32055
Phone: (386) 758-1388
Email: tbrazil@columbiacountyfla.com

Prepared By:

Company: Replay Systems
Contact: Ryan Hurley
Address: 6555 NW 9th Ave, Ste 105
Fort Lauderdale, FL 33309
Toll-Free: (800) 722-3472
Phone: (954) 821-6870
Email: ryan.hurley@replaysystems.com

OF CHANNELS: 46

OF POSITIONS:

NOTES: Columbia County Backup PSAP. VPI Voice Recording System- 46 channels.

Software

Quantity	Part Number	Description	List Price	Total Price
1	VP5-VP-100-S	V-Portal Suite system license. Sized to support systems up to 100 seats or recording channels.	\$2,150.00	\$2,150.00
45	VP5-CVR-Redundant	VPI CAPTURE REDUNDANT: Voice Recording License for redundant capture purposes only, per applicable terms. Per activated channel.	\$171.00	\$7,695.00
Subtotal:				\$9,845.00

Hardware

Quantity	Part Number	Description	List Price	Total Price
1	RPL-SVR-MIDTWR005-AIO	Mid Tower/500W 80Plus High Efficiency Power Supply All in One; Intel i3 3.4 GHz, 8 GB RAM, 500 GB Raid 1 x 2, 5 PCIe Slots, Windows Server 2012 STND R2 64 Bit, 1 DVD/Ram multi-drive, (Note: Hot swap power and Hot swap drives not available on this model)	\$4,750.00	\$4,750.00
2	RPL-Analog-24	24 Port Analog Interface Card	\$5,052.00	\$10,104.00
2	RPL-Cable15	15FT 25-Pair Cable (NON-DISCOUNTABLE)	\$73.00	\$146.00
Subtotal:				\$15,000.00

Services

Quantity	Part Number	Description	List Price	Total Price
1	RPL-INSTALL-ONSITE/REMOTE	Replay Systems onsite/remote installation services per day plus travel expenses, if applicable (1 Day Only)	\$1,800.00	\$1,800.00
Subtotal:				\$1,800.00

Subtotal (including additional services):	\$26,645.00
Installation Fee:	\$0.00
Tradein:	\$1,750.00
Grand Total:	\$24,895.00



VPI Empower 911



Presentation Date: 03/24/2017

Valid Until Date: 06/22/2017

Quote #: 001615

Rev: 03/28/2017 01:18 PM

Replay's Prepaid Performance Plans: Please check the plan you would like to purchase (optional).

- \$5,723 Prepaid Year 2-3 Assured Performance Plan (includes warranty plus 2 years of maintenance)
- \$8,584 Prepaid Year 2-4 Assured Performance Plan (includes warranty plus 3 years of maintenance)
- \$11,446 Prepaid Year 2-5 Assured Performance Plan (includes warranty plus 4 years of maintenance)

BRONZE SERVICE LEVEL: 24/7 phone support & fixes and enhancements within version. Amount quoted for budgetary purposes. May be added to total at customer's discretion.

I would not like to purchase an extended maintenance plan.

Payment Terms: Net 30 upon delivery

Customer Signature: _____
Print Name: _____ Title _____
Date: _____
PO Number: _____

Unless otherwise agreed, Payment Terms are NET 30 upon delivery.

Please read the attached "Installation Assumptions". These conditions apply to any purchase.

Prepaid Performance Plans include one year of warranty plus two, three, or four additional years of prepaid support respectively.



VPI Empower 911



Presentation Date: 03/24/2017
Valid Until Date: 06/22/2017

Quote #: 001615
Rev: 03/28/2017 01:18 PM

Replay Systems

The following assumptions were made in generating your installation & configuration pricing:

1. Customer is responsible for all data network infrastructure not purchased from Replay including switches, hubs, bridges, routers, external caching devices and cabling.
2. Customer is to provide prior to installation:
 - a. An accurate and complete document containing channel and/or position mappings for channel name, extension number, agent login, channel type (phone or radio), workstation IP address, computer name, and operating system. For VoIP systems: Complete list of all IP addresses and MAC addresses of all devices to be recorded. Setup of the SPAN port and any configuration to VoIP call manager is also responsibility of the customer.
 - b. LAN/WAN that supports TCP/IP protocol with static IP addresses for each recording appliance and server.
 - c. Sufficient space for the units and/or cabinets as well as sufficient entryway clearance for all system components. Temperatures are not to exceed 75 degrees in equipment room.
 - d. Sufficient power to the purchased recording system (including cabling and outlets) and UPS unless ordered with the system. Systems with two power supplies should be on two separate circuits.
 - e. A demarcation point, to include all required PBX, Radio and Network signals and associated hardware, to an easily accessible point within 15 feet of system. The Customer will clearly identify all cables with information indicating signal source and/or network connection and confirm they are fully operational.
 - f. A person to act as Project Manager to assist with the implementation and acceptance of the system above. Also must have administrator login credentials to load applications on desktops and to add recorder to domain, if required.
 - g. Customer agrees to allow remote system access via customer provided VPN, or our remote access software application for remote system diagnostics.
 - h. Any and all servers and workstations required but not ordered above.
 - i. Sufficient facilities to conduct all required training.
3. Replay is NOT responsible for any aspect of Union or other labor negotiations, procurement, contracting, use or payment.
4. Hours for implementation (and training) will be 8:00AM - 5:00PM Local Time Monday through Friday, excluding Replay and Customer holidays.
5. Unless otherwise noted above, standard installation covers the loading of workstation software on up to 4 customer supplied PCs. Additional PC installs will be completed under Time and Materials charges, minimum \$150 per PC, unless agreed upon prior to installation.
6. Additional system's components if required, such as Beep tone generators, D to A converters, etc. will be invoiced separately.
7. With regard to Digital phone systems, it is assumed that all phones are two wire unless otherwise specified. Four wire phones will require double channel count for recording and purchase of additional hardware and licenses.
8. Caller ID is only captured if available from the customer's phone system, as connected.
9. Replay resolves to work toward giving your Equipment availability approaching 100%. To do this, Replay will require remote access to the recorder, but always with prior knowledge, approval, and cooperation of Purchaser. If remote access is not permitted additional charges for warranty service will apply.
10. Unless otherwise agreed between both parties, warranty begins upon determination that all system channels are successfully recording and can be accessed through the recorder server or a network-connected workstation.
11. The system warranty will begin 10 days after delivery, unless otherwise agreed to by both parties.
12. Should installation be delayed more than 30 days at the customer's request, customer agrees to pay Replay the full amount of the invoice net 10 days after delivery.
13. Replay Systems sign off sheet reflects physical installation, network connectivity and recording of channels. Any additional configuration changes or additions outside the original SOW should not delay installation, acceptance.



2

COLUMBIA COUNTY BOARD OF COUNTY COMMISSIONERS
AGENDA ITEM REQUEST FORM

The Board of County Commissioners meets the 1st and 3rd Thursday of each month at 5:30 p.m. in the Columbia County School Board Administrative Complex Auditorium, 372 West Duval Street, Lake City, Florida 32055. All agenda items are due in the Board's office one week prior to the meeting date.

Today's Date: July 28, 2017 Meeting Date: August 3, 2017

Name: Penny Stanley Department: BCC Administration

Division Manager's Signature: Ben Scott

1. Nature and purpose of agenda item:

BCC Administration - Requesting Approval of Minutes - Board of County Commissioners - Regular Meeting - July 20, 2017

Attach any correspondence information, documents and forms for action i.e., contract agreements, quotes, memorandums, etc.

2. Fiscal impact on current budget.

Is this a budgeted item? [X] N/A [] Yes Account No. [] No Please list the proposed budget amendment to fund this request

Budget Amendment Number: Fund:

FROM: TO: AMOUNT:

For Use of County Manger Only:

[X] Consent Item [] Discussion Item

Columbia County
Board of County Commissioners

Minutes of
July 20, 2017

The Columbia County Board of County Commissioners met in a regular meeting at the auditorium of the School Board Administrative Complex at 5:30 p.m. The meeting opened with prayer and the Pledge of Allegiance to the Flag of the United States of America.

Commissioners in Attendance: Chairman Ronald Williams, Rusty DePratter, Tim Murphy, Bucky Nash and Everett Phillips.

Others in Attendance: County Manager Ben Scott ("CM")
Assistant County Manager Scott Ward ("ACM")
Assistant County Manager Kevin Kirby ("ACM")
County Attorney Joel Foreman
Deputy Clerk Katrina Vercher

Agenda Additions/Deletions

Additions:
None

Deletions:
Resolution No. 2017R-23

MOTION by Commissioner Phillips to approve the agenda as amended.
SECOND by Commissioner Nash. The motion carried unanimously.

Ministerial Matters

Fire Assessment Study

The County retained Tindale Oliver to prepare a study supporting an update of the County's fire protection special assessment rate schedule.

Using the attached PowerPoint presentation, Steve Tindale of Tindale Oliver, presented the results of the study.

Discussion ensued.

County Extension Office Highlights

Carree Musgrove, County UF/IFAS Extension Director, presented a video introducing County Extension faculty and staff. The video had highlights of the Extension Office's impact in the Community.

Proclamation No. 2017P-8

Commissioner Murphy read Proclamation No. 2017P-8 designating the week of July 16-22, 2017 Pretrial, Probation and Parole Supervision Week in Columbia County.

MOTION by Commissioner Murphy to approve Proclamation 2017P-8. SECOND by Commissioner Phillips. The motion carried unanimously.

Public Hearings:

Cypress Lake Business Park, Unit 1

SD 0176 – A request for a subdivision for portion of tax parcel 02433-001.

The public hearing opened and closed without comment.

MOTION by Commissioner Nash to approve SD 0176, Cypress Lake Business Park, Unit 1. SECOND by Commissioner DePratter. The motion carried unanimously.

Land Development Regulations ("LDR") Amendment

CPA 0225 -To amend Ordinance No.91-6 relating to an amendment to the future land use plan map of the Comprehensive Plan, from residential, very low density to residential, low density for parcel 025973-000. [Ordinance No. 2017-13]

The public hearing opened and closed without comment.

MOTION by Commissioner Nash to approve CPA 0225, Ordinance No. 2017-13. SECOND by Commissioner Phillips. The motion carried unanimously.

Florida-Friendly use of Fertilizer/Ordinance 2017-09 (adoption hearing)

An ordinance regulating the proper use of fertilizers, requiring proper training and establishing training and licensing requirements. It also establishes application rates and methods, fertilizer free zones; low maintenance zones and provides for exemptions and enforcement.

The public hearing opened.

Merrilee Malwitz-Jipson with the Sierra Club offered comment.

The public hearing closed.

Commissioner Murphy requested that a committee be formed of himself, the County Extension Office and perhaps Ms. Malwitz-Jipson to look into amending the ordinance.

MOTION by Commissioner Murphy to approve Ordinance No. 2017-09.
SECOND by Commissioner Phillips. The motion carried unanimously.

Public Comment on Discussion and Action Items:

Citizen Barbara Lemley offered comment on consent item #52 and the fire rate increase.

Citizen Jeffery Hill offered comment on case no. 17-132 CA.

MOTION by Commissioner Nash to approve the consent agenda. SECOND by Commissioner Phillips. The motion carried unanimously.

Consent Agenda:

- (1) BCC Administration - Appointment of Commissioner Bucky Nash to the Suwanee River Economic Council, Inc. Board of Directors
- (2) BCC Administration - Budget Amendment Request for Insurance Proceeds Estimate for Damaged HVAC Unit - Less Deductible - Unit was Damaged in Lightning Storm on April 3, 2017 - BA 17-61 - \$76,880
- (3) BCC Administration - Requesting Approval of Surplus Real Property
- (4) BCC Administration - Requesting Approval of the Recapitulation of Errors and Insolvencies for the 2016 Tax Roll - (\$2,207,830)
- (5) BCC Administration - Requesting Approval of Minutes - Board of County Commissioners - Special Meeting - May 18, 2017
- (6) BCC Administration - Requesting Approval of Minutes - Board of County Commissioners - Regular Meeting - May 18, 2017
- (7) BCC Administration - Requesting Approval of Minutes - Board of County Commissioners - Regular Meeting - May 25, 2017
- (8) BCC Administration - Requesting Approval of Minutes - Board of County Commissioners - Regular Meeting - June 1, 2017
- (9) BCC Administration - Requesting Approval of Minutes - Board of County Commissioners - Regular Meeting - June 15, 2017

- (10) Building and Zoning - Special Family Lot Permit - Oman Eugene Barber, Stepson – Patricia Ann Ward Barber, Property Owner
- (11) County Attorney - Requesting Approval of Interlocal Agreement for Mutual Assistance (Mutual Aid) - Columbia County and Suwannee County Fire-Rescue
- (12) County Attorney - Resolution 2017R-18 - Issue Certificate of Public Convenience and Necessity to the Columbia County Fire Rescue Department for ALS Services
- (13) County Attorney - Resolution 2017R-19 - Issue Certificate of Public Convenience and Necessity to Century Ambulance Service, Inc. to Provide EMS, Ambulance, and Transportation Services within the County
- (14) County Attorney - Resolution 2017R-20 - Issue Certificate of Public Convenience and Necessity to Century Ambulance Service, Inc., d/b/a Century EMS-Columbia County for EMS Ambulance and Transportation Services within the County
- (15) County Attorney - Resolution 2017R-22 - Authorizing County Manger to Enter Construction and Maintenance Agreement with the Florida Department of Transportation
- (16) Emergency Management - Requesting Approval of Emergency Management Preparedness and Assistance Grant (EMPA) - BA 17-59 - \$105,806
- (17) Emergency Management - Requesting Approval of the Emergency Management Performance Grant (EMPG) Contracts - BA 17-60 - \$52,150
- (18) Operations - Requesting Permission to Enter Private Property - James Hollnagel - Repair Water Runoff and Eroding Driveway - 309 SW Dairy Street
- (19) Operations - Requesting Permission to Enter Private Property - Don David Weiffenbach - Repair Washout - 362 Story Street after the fact
- (20) Operations - Requesting Permission to Enter Private Property - Arky Rogers - Dead Tree Removal and Fence Repair - Gabe Road and US 441 after the fact
- (21) Operations - Approval of FDOT Traffic Signal Maintenance Agreement #ARV18 - \$82,447
- (22) Operations - Utility Permit - City of Lake City - SW Michigan Street
- (23) Operations - Utility Permit - City of Lake City - SW Ring Court
- (24) Operations - Utility Permit - Comcast Cable - S Avalon Avenue and 138 SE Beech Street
- (25) Operations - Utility Permit - Comcast Cable - SE Academic Avenue
- (26) Operations - Utility Permit - Comcast Cable - SW Kessler Glen
- (27) Operations - Utility Permit - Comcast Cable - SW Fieldstone Court
- (28) Operations - Utility Permit - Comcast Cable - SE Rosewood Circle

- (29) Operations - Utility Permit - Comcast Cable - SW Silver Palm Drive
- (30) Operations - Utility Permit - Comcast Cable - SE Elm Loop and Rosewood Circle
- (31) Operations - Utility Permit - Florida Power and Light Company - NW Lake Jeffery Road
- (32) Operations - Utility Permit - Florida Power and Light Company - NW Brown Road
- (33) Operations - Utility Permit - Florida Power and Light Company - SW Koonville Road and Pinemount Road
- (34) Operations - Utility Permit - Florida Power and Light Company - NW Outlaw Glen and Nye Hunter Drive
- (35) Operations - Utility Permit - Florida Power and Light Company - Tomerline Lane, Pounds Hammock Road, County Road 363, Tyre Road, SE County Line Road, 12023 Road, Jefferson Road
- (36) Operations - Utility Permit - Florida Power and Light Company - NW Brown Road and Crossing Court
- (37) Operations - Utility Permit - Florida Power and Light Company - NW Brown Road and NW Celtic Court
- (38) Operations - Utility Permit - Florida Power and Light Company - NW Nash Road
- (39) Operations - Utility Permit - Florida Power and Light Company - NW Lake Jeffery Road, Scenic Lake Drive, and NW Bascom Norris Drive
- (40) Operations - Utility Permit - Florida Power and Light Company - NW Nash Road, NW Ranch Court, and NW Bert Avenue
- (41) Operations - Utility Permit - Florida Power and Light Company - NW Moore Road and NW Lake Jeffery Road
- (42) Operations - Utility Permit - Florida Power and Light Company - SW Birley Ave and SW Paces Glen
- (43) Operations - Utility Permit - Florida Power and Light Company - NW Moore Road
- (44) Operations - Utility Permit - Florida Power and Light Company - NW Noegel Road
- (45) Operations - Utility Permit - Florida Power and Light Company - NW Noegel Road
- (46) Operations - Utility Permit - Matilitie, LLC - County Road 252 and Highlands Avenue
- (47) Operations - Utility Permit - Windstream Florida - NW Newark Drive and SW Kentucky Street
- (48) Purchasing - Requesting Approval of Bid Award - Bid No. 2017-N - Low Bidder ADAPCO - \$14.38 per gallon

- (49) Public Library - Distribute Donated Funds to Appropriate Lines - BA 17-56 - \$832
- (50) Risk Management - Requesting Approval of Satisfaction of Mortgage - Betty Murphy – 134 NW Hensley Glen
- (51) Risk Management - Requesting Approval of Satisfaction of CDBG Housing Rehabilitation Grant Mortgage - Evon White - 534 SW Country Club Road
- (52) Risk Management - Adopt Resolution 2017R-17 - Establishing 2017 Price Index for Investor Owned Utilities
- (53) Risk Management - Requesting Amendment to Equipment Lease Agreement with Columbia County School District
- (54) Risk Management - Authorize Application for First Responders Comprehensive Addiction and Recovery Act Cooperative Agreement Grant with Substance Abuse and Mental Health Services Administration (SAMHSA) Providing Narcan to All First Responders
- (55) Solid Waste - Additional Funding from DOH (PO#AF97B) to Purchase Chemicals to Spray for Zika Virus - \$5,000 and from SRWMD to Spray Ichetucknee Springshed WQIP Project - \$1,396 - BA 17-58 - \$6,396
- (56) Tourist Development Council - Requesting Board Approval of the Updated Job Description - Sports Marketing Director

MOTION by Commissioner Nash to adopt the consent agenda.
 SECOND by Commissioner Phillips. The motion carried unanimously.

Discussion and Action Items:

Barwick Subdivision/Road Paving

Three bids were received on Bid No. 2017-4, C.A. Boone was the low bidder at \$293,760. Staff recommends approval.

MOTION by Commissioner Depratter to take staff recommendation. SECOND by Commissioner Phillips. The motion carried 4 to 1 with Commissioner Murphy voting in opposition.

Herlong Phase II Road Project

Staff was asked to give the Board an update on the progress of the project since the update on April 22, 2017. The status is unchanged. There are still five parcels that remain in negotiation. Staff is requesting a decision on the alignment of this phase. There are two opinions:

1. The current alignment

- A. Contains two 90 degree turns with stops
- B. Width from CR 131 to first stop to be 24'
- C. After second stop to SE 41 width can be increased from 18' to 22'
- D. Requires acquisition of seven parcels, three of which we have.
- E. Speed limit would have to be decreased

2. Proposed Alignment

- A. Eliminates two 90 degree turns
- B. Requires additional right-of-way
- C. Entire road would be widened to 24'
- D. Phase II would match Phase I

Discussion ensued.

Eminent Domain Resolution/Resolution No. 2017R-15

County Attorney Foreman requested that the Board approve Resolution 2017R-15 giving him the authority to begin eminent domain proceedings for the remaining parcels needed for the project or that they reject the resolution and leave the road alignment as is.

Discussion ensued.

MOTION by Commissioner Phillips to put the two (2) ninety's in the road and not try to acquire additional property. SECOND by Commissioner DePratter. The motion carried 3 to 2 with Commissioners Williams and Murphy voting in opposition.

Medical Marijuana Dispensaries

Staff is requesting direction from the Board regarding the regulation of medical marijuana dispensaries due to the passage of Senate Bill 8-A which provides the Board with the option to ban all such dispensaries within its jurisdiction as opposed to regulating their location.

Discussion ensued.

The following citizens spoke in favor of allowing the dispensaries:

- | | |
|-----------------|------------------|
| Voncile Creamer | Steve Andrews |
| Ryan Drew | Tracy Briggs |
| Delbert Mullins | Karen Mullins |
| Kyle Green | Sandra Buck-Camp |

Jimmy Johnson with Weed for Warriors spoke in favor.

Four representatives of Save Our Children spoke in opposition to dispensaries in Columbia County.

MOTION by Commissioner Murphy directing the County Attorney to prepare amendments to the Land Development Regulations to treat medical marijuana dispensaries as pharmacies as provided under the statute. SECOND by Commissioner Phillips. The motion carried unanimously.

Brown v. Columbia County

Trial counsel in this case has requested a meeting with the Board in a shade meeting to discuss litigation and settlement strategies. Attorney Foreman is requesting approval to set the meeting for August 3, 2017 at 2:00 p.m.

Discussion ensued.

MOTION by Commissioner DePratter to approve setting the shade meeting. SECOND by Commissioner Phillips. The motion carried unanimously.

Resolution No. 2017R-21/County Manager's Authority

Section 3.3(6) of the County Charter provides that the County Manager shall supervise the care and custody of all county property. This resolution is to make clear that the Board understands the scope of the County Manager's authority pursuant to the County Charter.

MOTION by Commissioner DePratter to approve Resolution No. 2017R-21. SECOND by Commissioner Phillips. The motion carried unanimously.

Board Rules and Policies

The County Attorney requested that the resolution to adopt new rules and policies governing the orderly and efficient operation of the Board be tabled until the next meeting.

Discussion ensued.

County Manager's Recommendations (PowerPoint attached):

BA 17-57 – Community Development Block Grant ("CDBG")

The County has been awarded a \$750,000 CDBG Subgrant Agreement with the Florida Department of Economic Opportunity for the Neighborhood Revitalization Project at Plantation Park. It requires an in-kind match of \$50,000 for engineering and labor. Staff recommends approval of the grant agreement.

Discussion ensued.

MOTION by Commissioner Murphy to approve the CDBG sub grant agreement and BA 17-57. SECOND by Commissioner Phillips. The motion carried unanimously.

Preliminary Rate Millage Rate

CM Scott requested permission to set two Public Hearings as required, to set the millage rate. CM Scott would like to schedule the first hearing on September 7, 2017 and the final hearing to adopt the budget at the September 21, 2017 regular scheduled meeting. He also asked that the Board set the preliminary mileage rate.

Discussion ensued.

MOTION by Commissioner Nash to set preliminary millage rate. Set millage and budget public hearing dates. SECOND by Commissioner Murphy.

Amended Motion by Commissioner Nash to set the preliminary millage rate at 8.87. Second by Commissioner Murphy.

The Chairman called for a vote. The motion carried 3 to 2 with Commissioners DePratter and Phillips voting in opposition.

Resolution No. 2017R-24 – Fire Protection Services

This is the preliminary rate resolution for an annual Fire Protection Assessment program in Columbia County for the fiscal year beginning October 1, 2017 and which initiates the annual process for updating the Assessment Roll.

Discussion ensued.

MOTION by Commissioner Nash to approve Preliminary Rate Resolution No. 2017R-24 for Fire Protection Services. SECOND by Commissioner Murphy. The motion carried 4 to 1 with Commissioner Williams voting in opposition.

Resolution No. 2017R-25 – Solid Waste Collection

This is the preliminary rate resolution for the collection and disposal of solid waste in Columbia County for the fiscal year beginning October 1, 2017 and authorizes the reimposition of annual Service Assessments for Solid Waste Collection and Disposal Services.

MOTION by Commissioner Murphy to approve Preliminary Rate Resolution No. 2017R-25 for Solid Waste and Disposal Services. SECOND by Commissioner Phillips. The motion carried unanimously.

Resolution No. 2017R-26 – Emerald Lake Street Lighting

This resolution is relating to the provision of street lighting services, facilities and programs for Emerald Lakes Street Lighting Municipal Service Benefit Unit and to estimate the cost of street lighting services to be accessed for the fiscal year beginning October 1, 2017.

MOTION by Commissioner Nash to approve Preliminary Rate Resolution No. 2017R-26 for Emerald Lake Street Lighting. SECOND by Commissioner Phillips. The motion carried unanimously.

Resolution No. 2017R-27 – Spring Hollow Street Lighting

This resolution is relating to the provision of street lighting services, facilities and programs for Spring Hollow Street Lighting Municipal Service Benefit Unit and to estimate the cost of street lighting services to be accessed for the fiscal year beginning October 1, 2017.

MOTION by Commissioner Nash to approve Preliminary Rate Resolution No. 2017R-27 for Spring Hollow Lighting. SECOND by Commissioner Phillips. The motion carried unanimously.

Resolution No. 2017R-28 – Carolyn Heights Street Lighting

This resolution is relating to the provision of street lighting services, facilities and programs for Carolyn Heights Street Lighting Municipal Service Benefit Unit (“MSBU”) and to estimate the cost of street lighting services to be accessed for the fiscal year beginning October 1, 2017.

MOTION by Commissioner DePratter to approve Preliminary Rate Resolution No. 2017R-28 for Carolyn Heights Street Lighting MSBU Initial Assessment. SECOND by Commissioner Murphy. The motion carried unanimously.

Resolution No. 2017R-29 – Pine Ridge Court

This resolution is to establish the estimated assessed cost for the properties that benefit from the Pine Ridge Road Improvement Project thereby directing the preparation of the updated assessment rolls to collect this cost for the fiscal year beginning October 1, 2017.

MOTION by Commissioner DePratter to approve Preliminary Rate Resolution No. 2017R-29 for Pine Ridge Court MSBU Local Improvement and Maintenance Assessment. SECOND by Commissioner Phillips. The motion carried unanimously.

Open Public Comments:

Citizen Barbara Lemley offered comment on the Lake Shore Hospital Authority. Commissioner Williams responded.

Citizen Merrilee Malwitz-Jipson requested public restrooms at all public access facilities.

Commissioner Comments:

Commissioner Murphy offered comment on the millage rate.

Commissioner DePratter asked that the cost to place porta potties at the Highway 27 Bridge and Hollingsworth Bluff be explored.

Adjournment

There being no further business, the meeting adjourned at 8:00 p.m.

ATTEST:

Ronald Williams, Chairman
Board of County Commissioners

P. DeWitt Cason
Clerk of Circuit Court



3

COLUMBIA COUNTY BOARD OF COUNTY COMMISSIONERS AGENDA ITEM REQUEST FORM

The Board of County Commissioners meets the 1st and 3rd Thursday of each month at 5:30 p.m. in the Columbia County School Board Administrative Complex Auditorium, 372 West Duval Street, Lake City, Florida 32055. All agenda items are due in the Board's office one week prior to the meeting date.

Today's Date: July 28, 2017 Meeting Date: August 3, 2017

Name: Scott Ward Department: BCC Administration

Division Manager's Signature: *Ben Scott*

1. Nature and purpose of agenda item:
Resolution 2017R-30 - Texting While Driving Ban

Attach any correspondence information, documents and forms for action i.e., contract agreements, quotes, memorandums, etc.

2. Fiscal impact on current budget.

Is this a budgeted item? N/A
 Yes Account No. _____
 No Please list the proposed budget amendment to fund this request

Budget Amendment Number: _____ Fund: _____

FROM: _____ TO: _____ AMOUNT: _____

For Use of County Manger Only:

Consent Item Discussion Item

District No. 1 - Ronald Williams
District No. 2 - Rusty DePratter
District No. 3 - Bucky Nash
District No. 4 - Everett Phillips
District No. 5 - Tim Murphy



BOARD OF COUNTY COMMISSIONERS • COLUMBIA COUNTY

MEMORANDUM

DATE: July 27, 2017

TO: Ben Scott, County Manager

FR: Scott Ward, Assistant County Manager - Administration

A handwritten signature in blue ink, appearing to read "Scott Ward".

RE: Resolution 2017R-30 Texting While Driving Ban

Florida Representative Emily Slosberg, District 91, reached out to the Board requesting the passage of a resolution supporting legislation that would make the ban on texting while driving a primary offense. Attached is the letter from Representative Slosberg and proposed resolution.

BOARD MEETS FIRST THURSDAY AT 5:30 P.M.
AND THIRD THURSDAY AT 5:30 P.M.

**COLUMBIA COUNTY, FLORIDA
RESOLUTION NO. 2017R-30**

**A RESOLUTION OF THE BOARD OF COUNTY COMMISSIONERS OF
COLUMBIA COUNTY, FLORIDA, URGING THE FLORIDA
LEGISLATURE TO ENACT LEGISLATION THAT WOULD MAKE
TEXTING WHILE DRIVING A PRIMARY OFFENSE**

WHEREAS, texting while driving makes the likelihood of a crash twenty-three times greater than driving while not distracted, according to the Virginia Tech Transportation Institute; and

WHEREAS, distracted driving is driving while performing another activity that shifts the driver's attention away from driving; and

WHEREAS, texting while driving is a form of distracted driving; and

WHEREAS, the National Highway Traffic Safety Administration (NHTSA) reported an estimated total of 967,000 crashes in the United States involving distracted drivers in 2014; and

WHEREAS, in 2014, approximately 431,000 people were injured in crashes in the United States involving distracted drivers, according to the NHTSA; and

WHEREAS, in 2014, 3,179 people were killed in crashes in the United States involving distracted drivers, according to the NHTSA; and

WHEREAS, the concern of the American public over distracted driving has grown exponentially, resulting in the first-ever national distracted driving enforcement and advertising campaign in April 2014 by the United States Department of Transportation; and

WHEREAS, in April 2015, the United States Transportation Secretary continued the national campaign by announcing the "U Drive. U Text. U Pay." Campaign for Distracted Driving Awareness month; and

WHEREAS, the degree of cognitive distraction associated with mobile phone use is so high that drivers using mobile phones exhibit greater impairment than legally intoxicated drivers, according to a University of Utah study; and

WHEREAS, a number of local jurisdictions have made it illegal to use hand-held cellular devices while driving; and

WHEREAS, on September 30, 2009, President Barack Obama issued an executive order prohibiting federal employees from texting while driving owned, leased, or rented government vehicles or driving and texting with government-supplied equipment; and

WHEREAS, on October 27, 2010, the Federal Motor Carrier Safety Administration enacted a ban prohibiting commercial vehicle drivers from texting while driving; and

WHEREAS, on December 13, 2011, the National Transportation Safety Board urged all states to prohibit the use of cellular telephones and text messaging while behind the wheel of a motor vehicle; and

WHEREAS, during the 2013 regular session, the Florida Legislature passed the Florida Ban on Texting While Driving Law, which made texting while driving a noncriminal traffic infraction; and

WHEREAS, as of March 2016, 46 states, the District of Columbia, Puerto Rico, Guam and the U.S. Virgin Islands have banned texting while driving for all drivers; and

WHEREAS, of the 46 states that have banned texting while driving, all but five have made texting while driving a primary offense; and

WHEREAS, Florida is among the five states that do not enforce texting while driving as a primary offense, but instead as a secondary offense; and

WHEREAS, a secondary offense is an offense for which a law enforcement officer can issue a ticket only if a driver has been pulled over for committing another traffic violation; and

WHEREAS, the Florida Legislature has considered bills that would make texting while driving a primary offense, however, to date, such bills have not been passed, allowing texting while driving to remain a secondary offense in Florida; and

WHEREAS, this Board urges the Florida Legislature to enact legislation that would make texting while driving a primary offense,

NOW, THEREFORE, BE IT RESOLVED by the Board of County Commissioners of Columbia County, Florida, that this Board:

SECTION 1. Urges the Florida Legislature to enact legislation that would make texting while driving a primary offense.

SECTION 2. Directs the Clerk of the Board to transmit a certified copy of this resolution to the Governor, Senate President, House Speaker, and the Chair and Members of the Columbia County State Legislative Delegation.

SECTION 3. Directs the County's state lobbyists to advocate for the passage of the legislation set forth in Section 2 above, and authorizes and directs the Office of Intergovernmental Affairs to include this item in the 2018 Legislative Package when it is presented to the Board.

PASSED AND DULY ADOPTED by the Board of County Commissioners of Columbia County, Florida, this day ____ of _____, 2017.

BOARD OF COUNTY COMMISSIONERS
COLUMBIA COUNTY, FLORIDA

By:

Ronald Williams, Chairman

(SEAL)

ATTEST:

Approval as to form and correctness:

P. DeWitt Cason, Clerk of Courts

Joel F. Foreman, County Attorney



4

COLUMBIA COUNTY BOARD OF COUNTY COMMISSIONERS AGENDA ITEM REQUEST FORM

The Board of County Commissioners meets the 1st and 3rd Thursday of each month at 5:30 p.m. in the Columbia County School Board Administrative Complex Auditorium, 372 West Duval Street, Lake City, Florida 32055. All agenda items are due in the Board's office one week prior to the meeting date.

Today's Date: July 28, 2017 Meeting Date: August 3, 2017

Name: Scott Wrd Department: BCC Administration

Division Manager's Signature: 

1. Nature and purpose of agenda item:

BCC Administration - Requesting the Approval of a Use of Space Agreement with the American Red Cross

Attach any correspondence information, documents and forms for action i.e., contract agreements, quotes, memorandums, etc.

2. Fiscal impact on current budget.

Is this a budgeted item? N/A
 Yes Account No. _____
 No Please list the proposed budget amendment to fund this request

Budget Amendment Number: _____ Fund: _____

FROM: _____ TO: _____ AMOUNT: _____

For Use of County Manger Only:

Consent Item Discussion Item

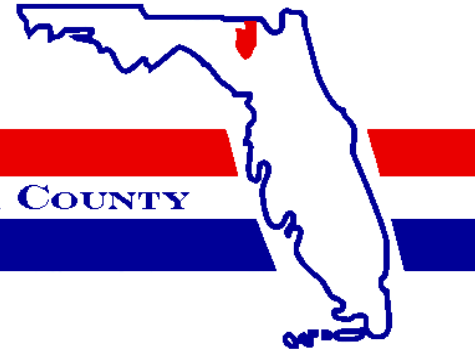

BOARD OF COUNTY COMMISSIONERS • COLUMBIA COUNTY

Memo

Date: April 20, 2017
To: Ben Scott, County Manager
From: Scott Ward, Assistant County Manager 
RE: License Agreement with American Red Cross

Our current License Agreement with American Red Cross for use of space within the Duval Place Building expires on 10/31/2017. They have requested that we extend the License Agreement for an additional two (2) years through 10/31/2019 by signing a new agreement that is the same as the current agreement with the exception of the dates and an Early Termination Clause granting either party may terminate the agreement for any reason upon sixty (60) days prior notice to the other party. We recommend the Board approve the license agreement as presented.

**STANDARD FORM OF SPACE LICENSE AGREEMENT
FOR THE TEMPORARY USE OF
FACILITIES**

(CUBICLE OR ROOM)

TERMS AND CONDITIONS

Effective Date: The date upon which this Agreement is effective, which will be the later of the dates of the signatures of Licensor and Licensee on this Form.

Leaser of the Facility (the "Licensor"):

Columbia County Board of Commissioners

Legal Name of the User of the Room (the "Licensee"):

The American National Red Cross, a nonprofit corporation, a Federally chartered instrumentality of the United States, and a body corporate and politic under the laws of the United States (36 U.S.C. §§ 300101-300111 (1998)).

Date Upon which the Licensee May Begin to Use the Room (the "Start Date"):

November 1, 2017

Date Upon Which the Licensee Must Vacate the Room (the "Expiration Date"):

October 31, 2019

Building Leaser and Licensor's Business Address:

P.O. Box 1529, Lake City, FL 32056

Room User and Licensee's Business Address:

9450 SW Gemini Dr., #75048, Beaverton, OR 97008-7105

Street Address of the Building Where the Room is Located:

971 West Duval Street, Suite 140, Lake City, FL 32055

Permitted Use(s) of Licensed Room (check those applicable):

- General Office
- Training and/or Testing
- Storage

Description of Licensed Room:

2 offices, 2 classrooms, and a portion of the warehouse – 3,029 sq. ft total

This Temporary Space License Agreement (the “Agreement”) is dated and intended to be effective as of the Effective Date set forth above, and made by and between the Licensor and the Licensee named above. Under the Agreement, the Licensee is permitted to use and occupy, on a temporary basis, the space described above (the “Room”) in the Building at the Location set forth above (the “Building”).



1. Grant of License. Licensor grants Licensee the right to use the Room for the Permitted Use(s) described above. This license includes reasonable ingress and egress to and from the Room through the Building’s common areas. Licensee shall not have the right to use any other space in the Building (such as library, conference rooms, break room, coffee room) or any equipment belonging to Licensor unless the Licensor gives written permission to do so. This Agreement is not a lease and Licensee is granted no leasehold interest in the Room.
2. Term. Licensee’s right to use the Premises shall begin on the Start Date and shall end on the Expiration Date. On or before the Expiration Date, Licensee shall vacate the Room. Licensee shall repair all damage caused by Licensee’s occupancy, at Licensee’s sole cost and expense.
3. Early Termination. Either party may terminate this agreement for any reason upon sixty (60) days prior notice to the other party.
4. License Fee. Licensee shall pay, as a license fee, the amount of \$ 0.00.

5. Licensee's Conduct. Licensee agrees to keep the Room in good condition and promptly repair all damage to the Premises or the Building caused by Licensee negligence, and not to disrupt, adversely affect or interfere with other occupants of the Building.
6. Condition of Premises and Building. Licensor makes no warranty or representation about the Room or the Building. Licensee accepts the same "AS IS." Licensor is under no obligation to prepare or repair the Room or the Building for Licensee.
7. Indemnification. Licensee shall defend, hold harmless, and indemnify Licensor against any legal liability, including reasonable attorney fees, in respect to bodily injury, death, and property damage arising from the negligence of the said Licensee during its use of the Room.
8. Insurance. Licensee shall carry the following insurance coverage:
 - A. Commercial General Liability with an occurrence limit of at least one-million dollars (\$1,000,000) and an aggregate limit of at least two-million dollars (\$2,000,000);
 - B. Commercial Automobile Liability with a combined single limit of at least one-million dollars (\$1,000,000);
 - C. Workers Compensation coverage with statutory limits for the jurisdiction in which the premises are located and Employers' Liability with limits of at least one million dollars (\$1,000,000.00) per accident, one million dollars (\$1,000,000.00) disease – each employee and one million dollars (\$1,000,000.00) disease – policy limit.
8. Licensor's Right to Revoke License. Upon reasonable prior written notice to Licensee, Licensor may revoke the license represented by this Agreement if Licensee (a) fails to pay any fee or payment required hereunder or (b) breaches any other obligation hereunder and such breach continues after written notice from Licensor describing same. If this license is so revoked, Licensee shall forthwith vacate the Room in a neat and orderly manner. Licensor shall have all rights and remedies available to it under applicable law.
9. No Assignment. Licensee shall not, and shall not have any right to, assign or transfer, or sublicense this Agreement. Licensor shall have no obligation to consider or approve any such transfer, regardless of the circumstances.

10. Casualty or Condemnation Affecting Premises. Notwithstanding anything in this Agreement to the contrary, in the event that damage or casualty to all or a part of the Room, this License shall terminate and Licensee shall have no right to restoration of the Room or to receive any compensation whatsoever.
11. Notice. Notice shall be deemed to have been duly given three (3) business days after having been mailed by certified or registered mail, return receipt requested, to the party's address set forth at the beginning of the Agreement, or upon receipt if delivered by hand or recognized overnight delivery service. Either party may change its address for the purpose of notice hereunder by providing the other party with notice of the new address.
12. Governing Law and Binding Effect. This Agreement shall be governed by and construed under the laws of the state in which the Building is located. This Agreement shall be binding on the parties and their respective, successors, transferees and assigns.
13. Brokers/Consultants. Licensor and Licensee each represent to the other that there is no broker in this transaction. Each party shall indemnify the other against the claims of any broker.
14. Authority. Each party represents and warrants that it has the full power and authority to execute, deliver and perform under this Agreement.

Signatures are on the next page.

AMERICAN NATIONAL RED CROSS
AND "LICENSEE:"

B_ 
M R p E Q
D 
L

BUILDING OWNER AND
"LICENSOR:"

By: _____
(Signature)

Name:

Title:

Date:



5

COLUMBIA COUNTY BOARD OF COUNTY COMMISSIONERS
AGENDA ITEM REQUEST FORM

The Board of County Commissioners meets the 1st and 3rd Thursday of each month at 5:30 p.m. in the Columbia County School Board Administrative Complex Auditorium, 372 West Duval Street, Lake City, Florida 32055. All agenda items are due in the Board's office one week prior to the meeting date.

Today's Date: July 19, 2017 Meeting Date: August 3, 2017

Name: Brandon M. Stubbs Department: Building And Zoning

Division Manager's Signature: [Handwritten Signature]

1. Nature and purpose of agenda item:

Special Family Lot Permit (SFLP 17 04) - A request by Kaleb and Courtney Bedenbaugh to create a Special Family Lot for Beverly Stone - Mother of Courtney Bedenbaugh.

Attach any correspondence information, documents and forms for action i.e., contract agreements, quotes, memorandums, etc.

2. Fiscal impact on current budget.

Is this a budgeted item? [X] N/A [] Yes Account No. [] No Please list the proposed budget amendment to fund this request

Budget Amendment Number: Fund:

FROM: TO: AMOUNT:

For Use of County Manger Only:

[X] Consent Item [] Discussion Item



Columbia County Gateway to Florida

FOR PLANNING USE ONLY

Application # SFLP 17-40
 Application Fee \$50.00
 Receipt No. 4771
 Filing Date 7-14-17
 Completeness Date 7-19-17

Special Family Lot Permit Application

A. PROJECT INFORMATION

- Title Holder's Name: Kaleb Bedenbaugh & Courtney Bedenbaugh
- Address of Subject Property: 4078 SE Country Club Rd. Lake City, 32025
- Parcel ID Number(s): 869400
- Future Land Use Map Designation: _____
- Zoning Designation: _____
- Acreage of Parent Parcel: 6
- Acreage of Property to be Deeded to Immediate Family Member: 2
- Existing Use of Property: Single Family Residence
- Proposed use of Property: Residence
- Name of Immediate Family Member for which Special Family Lot is to be Granted: Beverly Stone

PLEASE NOTE: Immediate family member must be a parent, grandparent, adopted parent, stepparent, sibling, child, adopted child, stepchild, or grandchild of the person who is conveying the parcel to said individual.

B. APPLICANT INFORMATION

- Applicant Status: Owner (title holder) Agent
- Name of Applicant(s): Kaleb Bedenbaugh & Courtney Bedenbaugh Title: _____
 Company name (if applicable): _____
 Mailing Address: 4078 SE Country Club Rd.
 City: Lake City State: Florida Zip: 32025
 Telephone: (386) 292-2494 Fax: () Email: BBmotorsports39@gmail.com

PLEASE NOTE: Florida has a very broad public records law. Most written communications to or from government officials regarding government business is subject to public records requests. Your e-mail address and communications may be subject to public disclosure.

- If the applicant is agent for the property owner*.
 Property Owner Name (title holder): _____
 Mailing Address: _____
 City: _____ State: _____ Zip: _____
 Telephone: () _____ Fax: () _____ Email: _____

PLEASE NOTE: Florida has a very broad public records law. Most written communications to or from government officials regarding government business is subject to public records requests. Your e-mail address and communications may be subject to public disclosure.

***Must provide an executed Property Owner Affidavit Form authorizing the agent to act on behalf of the property owner.**

C. ATTACHMENT/SUBMITTAL REQUIREMENTS

1. Map, Drawing, or Sketch of Parent Parcel Showing the Location of the Proposed Lot being Deeded to Immediate Family Member with Appropriate Dimensions (Must be a Minimum of One Acre).
2. Personal Identification and Proof of Relationship, to Establish the Required Immediate Family Member Status, of both the Parent Parcel Owner and the Immediate Family Member. The Personal Identification Shall Consist of Original Documents or Notarized Copies from Public Records. Such Documents may include Birth Certificates, Adoption Records, Marriage Certificates, and/or Other Public Records.
3. Family Relationship Residence Agreement Affidavit is Required Stating that the Special Family Lot is being Created as a Homestead by the Immediate Family Member, that the Immediate Family Member shall obtain Homestead Exemption on the Lot. This Affidavit shall be Recorded in the Clerk of Courts Office.
4. Legal Description of Parent Parcel with Acreage (In Microsoft Word Format).
5. Legal Description of Property to be Deeded to Immediate Family Member with Acreage (In Microsoft Word Format).
6. Legal Description of Parent Parcel with Immediate Family Member Lot Removed with Acreage (In Microsoft Word Format).
7. Proof of Ownership (i.e. deed).
8. Agent Authorization Form, if applicable (signed and notarized).
9. Proof of Payment of Taxes (can be obtained online via the Columbia County Tax Collector's Office).
10. Fee. \$50.00 - No application shall be accepted or processed until the required application fee has been paid.

NOTICE TO APPLICANT

A special family lot permit may be issued by the Board of County Commissioners on land zoned Agricultural or Environmentally Sensitive Area within these Land Development Regulations, for the purpose of conveying a lot or parcel to an immediate family member who is the parent, grandparent, adopted parent, stepparent, sibling, child, or adopted child, stepchild or grandchild of the person who conveyed the parcel to said individual, **not to exceed one (1) dwelling unit per one (1) acre** and the lot complies with all other conditions from permitting development as set forth in these Land Development Regulations. This provision is intended to promote the perpetuation of the family homestead in rural areas by making it possible for immediate family members to reside on lots as their primary residence which exceed maximum density for such areas, provided that the lot complies with the conditions for permitting established in Section 14.9 of the Land Development Regulations.

If approved by the Board of County Commissioner, the division of lots shall be recorded by separate deed, comply with all other applicable regulations of the Land Development Regulations, and comply with all other conditions for permitting and development as set forth in the Land Development Regulations. A completed building permit application shall be submitted within one (1) year of receiving approval by the Board of County Commissioners. One (1) extension can be requested in writing and approved by the Land Development Regulations Administrator not to exceed nine (9) months. If a special family lot permit expires, it shall have to go through the process again for approval as required by this section. A building permit for a special family lot shall be issued only to the immediate family member or their authorized representative (i.e. licensed building contractor or mobile home installer) after a recorded copy of the family relationship residence agreement affidavit and deed to the special family lot has been submitted to the Land Development Regulation Administrator as part of the building permit application process.

Special family lots which have not met the requirements for homestead exemption shall not be transferable except, as follows:

1. The deeding of the parcel back to the original owner of the parent tract as indicated in Section 14.9 of the Land Development Regulations;
2. To another individual meeting the definition of immediate family member;
3. To an individual not meeting the definition of immediate family member due to circumstances beyond the reasonable control of the family member to whom the original special family lot permit was granted such as divorce, death or job change resulting in unreasonable commuting distances, the immediate family member is no longer able to retain ownership of the special family lot, subject to approval by the original reviewing body that approved the special family lot permit; and
4. Upon approval of the transfer of the special family lot, the County will issue a Certificate of Transfer and the owner shall record the certificate in the Public Records in the Clerk of the Courts Office. This process shall apply retroactively to special family lots previously created under the Land Development Regulations.

Any decision made by the Board of County Commissioners is subject to a 30 day appeal period as outlined in Article 12 of the Land Development Regulations. Any action taken by the applicant within the 30 day appeal period is at the applicant's risk. No Certificate of Occupancy shall be issued until the 30 day appeal period is over or until any appeal has been settled.

Upon the applicant obtaining a Certificate of Occupancy, the applicant must file for Homestead Exemption. Homestead Exemptions can be filed each year with the Columbia County Property Appraiser's Office from January 1 to March 31.

Once an application is submitted and paid for, a completeness review will be done to ensure all the requirements for a complete application have been met. If there are any deficiencies, the applicant will be notified in writing. If an application is deemed to be incomplete, it may cause a delay in the scheduling of the application before the Planning & Zoning Board.

THE APPLICANT ACKNOWLEDGES THAT THE APPLICANT OR AGENT MUST BE PRESENT AT THE PUBLIC HEARING BEFORE THE PLANNING AND ZONING BOARD, AS ADOPTED IN THE BOARD RULES AND PROCEDURES, OTHERWISE THE REQUEST MAY BE CONTINUED TO A FUTURE HEARING DATE.

I hereby certify that all of the above statements and statements contained in any documents or plans submitted herewith are true and accurate to the best of my knowledge and belief.

Kaleb Bedenbaugh Courtney Bedenbaugh

Applicant/Agent Name (Type or Print)

Kaleb Bedenbaugh Courtney Bedenbaugh 6/12/2017

Applicant/Agent Signature

Date

FAMILY RELATIONSHIP AFFIDAVIT

STATE OF FLORIDA
COUNTY OF COLUMBIA

BEFORE ME the undersigned Notary Public personally appeared, Courtney
Bedenbaugh the Owner of the parent parcel which has been subdivided for and
Beverly Stone, the Immediate Family Member of the Owner, which is
intended for the Immediate Family Members primary residence use. The Immediate Family
Member is related to the Owner as Grandmother. Both individuals being
first duly sworn according to law, depose and say:

1. Affiant acknowledges Immediate Family Member is defined as parent, grandparent, step-parent, adopted parent, sibling, child, step-child, adopted child or grandchild.
2. Both the Owner and the Immediate Family Member have personal knowledge of all matters set forth in this Affidavit.
3. The Owner holds fee simple title to certain real property situated in Columbia County, and more particularly described by reference with the Columbia County Property Appraiser Parent Tract Tax Parcel No. 22-45-17-08694-000
4. The Immediate Family Member holds fee simple title to certain real property divided from the Owners' parent parcel situated in Columbia County and more particularly described by reference to the Columbia County Property Appraiser Tax Parcel No. 22-45-17-08694-
5. No person or entity other than the Owner and Immediate Family Member to whom permit is being issued, including persons residing with the family member claims or is presently entitled to the right of possession or is in possession of the property, and there are no tenancies, leases or other occupancies that affect the property.
6. This Affidavit is made for the specific purpose of inducing Columbia County to recognize a family division for an Immediate Family Member being in compliance with the density requirements of the Columbia County's Comprehensive Plan and Land Development Regulations (LDR's).
7. This Affidavit and Agreement is made and given by Affiants with full knowledge that the facts contained herein are accurate and complete, and with full knowledge that the penalties under Florida law for perjury include conviction of a felony of the third degree.

We Hereby Certify that the facts represented by us in this Affidavit are true and correct and we accept the terms of the Agreement and agree to comply with it.

Courtney Bedenbaugh
Owner

Beverly Stone
Immediate Family Member

Courtney Bedenbaugh
Typed or Printed Name

Beverly Stone
Typed or Printed Name

State of Florida
County of Columbia

Subscribed and sworn to (or affirmed) before me this 14th day of July, 2017,
by Courtney Bedenbaugh (Owner) who is personally known to me or has produced
FL Driver License as identification.

Angela Cox
Notary Public Angela Cox

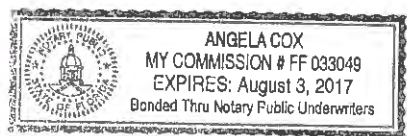

Subscribed and sworn to (or affirmed) before me this 14th day of July, 2017,
by Beverly Stone (Family Member) who is personally known to me or has
produced Utah Driver License as identification.

Angela Cox
Notary Public Angela Cox



APPROVED:
COLUMBIA COUNTY, FLORIDA

By: _____

Name: _____

Title: _____

Rec. 18.⁵⁰
Doc. Lett. ⁰⁰ } 634.⁵⁰

Return To/Prepared By:
North Central Title, Inc.
7404 State Road 21
Keystone Heights, FL 32656
File No. 2017-998

Instr: 20171289/447 Date: 04/24/2017 Time: 10:58AM
Page 1 of 2 H: 1335 F: 944, P.DeWitt Cannon, Clerk of Court
Columbia, County, By: BD
Deputy ClerkDoc Stamp-Deed: 616.00

WARRANTY DEED

THIS DEED made on this 12th day of April, 2017, by and **Louise Tardif a/k/a Louise M. Tardif, an unmarried widow**, whose address is 2266 SE County Road 252, Lake City, FL 32025, as Grantors, and **Kaleb Bedenbaugh**, whose mailing address is 5928 SW CR 751, Jasper, FL 32052, as Grantee

Grantor, for and in consideration of the sum of Ten and 00/100 Dollars (10.00), receipt whereof is hereby acknowledged, hereby grants, bargains, conveys and sells to Grantee, the real property located in the County of **Columbia**, State of Florida, to-wit:

As described on Exhibit "A" attached hereto.

TOGETHER with all the tenements, hereditaments and appurtenances thereto belonging or in anywise appertaining.

TO HAVE AND HOLD, the same in fee simple forever.

AND the grantor hereby covenants with said grantee that the grantor is lawfully seized of said land in fee simple; that the grantor has good right and lawful authority to sell and convey said land; that the grantor hereby fully warrants the title to said land and will defend the same against the lawful claims of all persons whomsoever; and that said land is free of all encumbrances except Easements and Restrictions of Record and Taxes accruing subsequent to December 31, 2016.

IN WITNESS WHEREOF, the Grantor has hereunto signed and sealed these presents the day and year first above written.

Signed, sealed and delivered
in the presence of:

Leslie C. Snyder
Signature of 1st Witness

Louise M. Tardif
Louise Tardif a/k/a Louise M. Tardif

Leslie C. Snyder
Printed Name of 1st Witness

Ch. DuHany
Signature of 2nd Witness

Ebony Green Harvey
Printed Name of 2nd Witness

**STATE OF FLORIDA
COUNTY OF UNION**

I **HEREBY CERTIFY** that on this day, before me, an officer duly qualified to take acknowledgments, personally appeared, **Louise Tardif a/k/a Louise M. Tardif** who produced a Florida Driver's License as identification and who executed the foregoing instrument and acknowledged before me the execution of same.

WITNESS my hand and official seal in the County and State last aforesaid this 12th day of April, 2017.



Leslie C. Snyder
Notary Public

EXHIBIT "A"

SECTION 22, TOWNSHIP 4 SOUTH, RANGE 17 EAST:

A PART OF THE SW 1/4 OF THE NW 1/4 OF SECTION 22, TOWNSHIP 4 SOUTH, RANGE 17 EAST, COLUMBIA COUNTY, FLORIDA, MORE PARTICULARLY DESCRIBED AS FOLLOWS:

COMMENCE AT THE SOUTHWEST CORNER OF THE NW 1/4 OF SAID SECTION 22, AND RUN N 01 DEGREES 30 MINUTES 08 SECONDS W, ALONG THE WEST LINE OF SAID SECTION 22, A DISTANCE OF 39.97 FEET TO THE NORTH RIGHT-OF-WAY OF COUNTY ROAD #133B (S.E. RACE TRACK ROAD LANE) FOR A POINT OF BEGINNING, THENCE CONTINUE N 01 DEGREES 30 MINUTES 08 SECONDS W, ALONG SAID WEST LINE A DISTANCE OF 1276.94 FEET TO THE NORTHWEST CORNER OF THE SAID SW 1/4 OF NW 1/4, THENCE N 88 DEGREES 57 MINUTES 23 SECONDS E, ALONG THE NORTH LINE, OF SAID SW 1/4 OF NW 1/4 A DISTANCE OF 38.21 FEET TO AN IRON ROD AND CAP IN AN OLD FENCE LINE, THENCE S 00 DEGREES 59 MINUTES 29 SECONDS E, ALONG THE MEANDER OF SAID OLD FENCE LINE A DISTANCE OF 1276.94 FEET TO A CONCRETE MONUMENT ON THE NORTH LINE OF THE SAID COUNTY ROAD #133B, THENCE S 89 DEGREES 16 MINUTES 50 SECONDS W, ALONG SAID RIGHT-OF-WAY A DISTANCE OF 27.85 FEET TO THE POINT OF BEGINNING.

AND

SECTIONS 21 & 22, TOWNSHIP 4 SOUTH, RANGE 17 EAST:

A PART OF THE NORTHWEST 1/4 OF SECTION 22 AND PART OF THE NORTHEAST 1/4 OF SECTION 21, ALL IN TOWNSHIP 4 SOUTH, RANGE 17 EAST, COLUMBIA COUNTY, FLORIDA, MORE PARTICULARLY DESCRIBED AS FOLLOWS:

BEGIN AT THE NORTHWEST CORNER OF SAID SECTION 22 AND RUN N 88 DEGREES 39 MINUTES 02 SECONDS E, ALONG THE NORTH LINE THEREOF, 1075.97 FEET; THENCE S 01 DEGREES 24 MINUTES 05 SECONDS EAST, 104.98 FEET; THENCE N 88 DEGREES 35 MINUTES 10 SECONDS E, 209.93 FEET TO THE WEST RIGHT-OF-WAY LINE OF COUNTY ROAD NO. 133; THENCE S 01 DEGREES 26 MINUTES 48 SECONDS E, ALONG SAID RIGHT-OF-WAY LINE, 1220.19 FEET; THENCE S 88 DEGREES 57 MINUTES 28 SECONDS W, 1662.85 FEET; THENCE N 02 DEGREES 02 MINUTES 58 SECONDS W, 1064.16 FEET; THENCE N 88 DEGREES 51 MINUTES 11 SECONDS E, 21.53 FEET; THENCE N 02 DEGREES 02 MINUTES 58 SECONDS W, 252.00 FEET TO THE NORTH LINE OF AFOREMENTIONED SECTION 21; THENCE N 88 DEGREES 37 MINUTES 39 SECONDS E, ALONG SAID NORTH LINE OF SECTION 21, 369.30 FEET TO THE POINT OF BEGINNING.

QUITCLAIM DEED

Inst: 201712013137 Date: 07/13/2017 Time: 4:41PM
Page 1 of 1 B: 13-40 P: 1622 P.DeWitt Cason, Clerk of Court
Columbia County, By: BD
Deputy Clerk Doc Stamp-Deed: 0.70

KNOW ALL MEN BY THESE PRESENTS:

That I (we) Kaleb Bedenbaugh, the undersigned, for the consideration of Ten Dollars (\$10.00), and other valuable considerations, do hereby release, remise, and forever quitclaim unto Kaleb Bedenbaugh and Courtney Bedenbaugh, husband and wife, all right, title and interest in that certain property situated in Columbia County, State of Florida, and described as follows:

A PART OF THE NW 1/4 OF SECTION 22, TOWNSHIP 4 SOUTH, RANGE 17 EAST, COLUMBIA COUNTY, FLORIDA, MORE PARTICULARLY DESCRIBED AS FOLLOWS: COMMENCE AT THE NW CORNER OF SAID SECTION 22 AND RUN N.88°39'02"E., ALONG THE NORTH LINE THEREOF, 1075.97 FEET; THENCE S.01°24'05"E., 104.98 FEET; THENCE N.88°35'10"E., 209.93 FEET TO THE WEST RIGHT-OF-WAY LINE OF COUNTY ROAD NO. 133; THENCE S.01°26'48"E., ALONG SAID RIGHT-OF-WAY LINE, 957.91 FEET TO THE POINT OF BEGINNING; THENCE CONTINUE S.01°26'48"E., 262.28 FEET; THENCE S.88°57'28"W., 996.52 FEET; THENCE N.01°26'48"W., 262.28 FEET; THENCE N.88°57'28"E., 996.52 FEET TO THE POINT OF BEGINNING. CONTAINING 6.00 ACRES, MORE OR LESS.

IN WITNESS WHEREOF, I (we) have hereunto set my (our) hand(s) and seal this 13th day of July, 2017.

Kaleb Bedenbaugh
Printed Name of Releasor
Jennifer Bonfiglio
Printed Name of Witness
Angela Cox
Printed Name of Witness

Kaleb Bedenbaugh
Signature of Releasor
Jennifer Bonfiglio
Signature of Witness
Angela Cox
Signature of Witness

State of Florida
County of Columbia

On this 13th day of July, 2017, before me, the undersigned Notary Public, personally appeared Kaleb Bedenbaugh, known to me to be the individual who executed the foregoing instrument and acknowledged the same to be his free act and deed.



Angela Cox
Notary Public
My Commission expires: 08-03-2017

Personally Known
Produced Identification
Type of Identification FL Driver License Exp. 10-21-2019

Columbia County Property Appraiser

updated: 6/6/2017

2016 Tax Year

Tax Collector Tax Estimator Property Card

Parcel List Generator

Parcel: 22-4S-17-08694-000

<< Next Lower Parcel Next Higher Parcel >>

2016 TRIM (pdf)

Interactive GIS Map

Print

Owner & Property Info

Search Result: 1 of 1

Owner's Name	BEDENBAUGH KALEB		
Mailing Address	5928 SW CR 751 JASPER, FL 32052		
Site Address	4078 SE COUNTRY CLUB RD		
Use Desc. (code)	IMPROVED A (005000)		
Tax District	3 (County)	Neighborhood	22417
Land Area	38.470 ACRES	Market Area	02
Description	NOTE: This description is not to be used as the Legal Description for this parcel in any legal transaction. BEG NW COR, RUN E 1075.97 FT, S 104.98 FT, E 209.93 FT TO W R/W CR-133, S ALONG R/W 1220.19 FT, W TO W SEC LINE, N TO POB. (AKA NW1/4 OF NW1/4, EX 105 FT N & S BY 210 FT E & W IN NE COR) ALSO COMM SW COR OF NW1/4 RUN N 39.97 FT TO THE N R/W LINE CO RD 133-B FOR POB CONT N 1276.94 FT TO NW COR OF SW1/4 OF NW1/4 RUN E 38.21 FT, S 1276.94 FT TO N RW LINE OF CO RD 133-B, THENCE W 27.85 FT TO POB. 816- ...more>>>		



Property & Assessment Values

2016 Certified Values		
Mkt Land Value	cnt: (1)	\$3,653.00
Ag Land Value	cnt: (2)	\$8,618.00
Building Value	cnt: (1)	\$10,984.00
XFOB Value	cnt: (2)	\$31,728.00
Total Appraised Value		\$54,983.00
Just Value		\$146,436.00
Class Value		\$54,983.00
Assessed Value		\$54,712.00
Exempt Value	(code: HX H3)	\$24,712.00
Total Taxable Value	Cnty: \$30,000 Other: \$30,000 Schl: \$30,000	

2017 Working Values (...Hide Values)		
Mkt Land Value	cnt: (1)	\$3,653.00
Ag Land Value	cnt: (2)	\$8,805.00
Building Value	cnt: (1)	\$11,203.00
XFOB Value	cnt: (2)	\$31,728.00
Total Appraised Value		\$55,389.00
Just Value		\$146,655.00
Class Value		\$55,389.00
Assessed Value		\$55,237.00
Exempt Value	(code: HX H3)	\$25,000.00
Total Taxable Value	Cnty: \$30,237 Other: \$30,237 Schl: \$30,237	

NOTE: 2017 Working Values are NOT certified values and therefore are subject to change before being finalized for ad valorem assessment purposes.

Sales History

Show Similar Sales w ithin 1/2 mile

Sale Date	OR Book/Page	OR Code	Vacant / Improved	Qualified Sale	Sale RCode	Sale Price
4/12/2017	1335/944	WD	I	U	37	\$88,000.00
1/26/2017	1329/2595	PB	I	U	18	\$0.00
4/21/2011	1213/1318	WD	V	U	11	\$100.00
1/30/2002	945/1804	WD	V	U	08	\$87,500.00

Building Characteristics

Bldg Item	Bldg Desc	Year BIt	Ext. Walls	Heated S.F.	Actual S.F.	Bldg Value
1	MOBILE HME (000800)	1986	AL SIDING (26)	1404	1404	\$11,203.00

Note: All S.F. calculations are based on exterior building dimensions.

Extra Features & Out Buildings

Code	Desc	Year Blt	Value	Units	Dims	Condition (% Good)
0030	BARN,MT	2004	\$30,000.00	0003000.000	50 x 60 x 0	(000.00)
0070	CARPORT UF	2005	\$1,728.00	0000576.000	24 x 24 x 0	(000.00)

Land Breakdown

Lnd Code	Desc	Units	Adjustments	Eff Rate	Lnd Value
000200	MBL HM (MKT)	1 AC	1.00/1.00/1.00/1.00	\$2,403.63	\$2,403.00
006200	PASTURE 3 (AG)	37.47 AC	1.00/1.00/1.00/1.00	\$235.00	\$8,805.00
009910	MKT.VAL.AG (MKT)	37.47 AC	1.00/1.00/1.00/1.00	\$0.00	\$100,071.00
009946	WELL (MKT)	1 UT - (0000000.000AC)	1.00/1.00/1.00/1.00	\$1,250.00	\$1,250.00

Columbia County Property Appraiser

updated: 6/6/2017

DISCLAIMER

This information was derived from data which was compiled by the Columbia County Property Appraiser Office solely for the governmental purpose of property assessment. This information should not be relied upon by anyone as a determination of the ownership of property or market value. No warranties, expressed or implied, are provided for the accuracy of the data herein, it's use, or it's interpretation. Although it is periodically updated, this information may not reflect the data currently on file in the Property Appraiser's office. The assessed values are NOT certified values and therefore are subject to change before being finalized for ad valorem assessment purposes.

Columbia County Tax Collector

generated on 7/14/2017 2:56:57 PM EDT

Tax Record

Last Update: 7/14/2017 2:56:57 PM EDT

Register for eBill

Ad Valorem Taxes and Non-Ad Valorem Assessments

The information contained herein does not constitute a title search and should not be relied on as such.

Account Number

R08694-000

Tax Type

REAL ESTATE

Tax Year

2016

Mailing Address

TARDIF ROLAND L (ESTATE)
LOUISE TARDIF AS PER REP
4078 SE COUNTRY CLUB ROAD
LAKE CITY FL 32025

Property Address

4078 COUNTRY CLUB SE LAKE CITY

GEO Number

224S17-08694-000

Exempt Amount

See Below

Taxable Value

See Below

Exemption Detail

HX 24712

Millage Code

003

Escrow Code

Legal Description (click for full description)

22-4S-17 5000/5000 38.47 Acres BEG NW COR, RUN E 1075.97 FT, S 104.98 FT, E 209.93 FT TO W R/W CR-133, S ALONG R/W 1220.19 FT, W TO W SEC LINE, N TO POB. (AKA NW1/4 OF NW1/4, EX 105 FT N & S BY 210 FT E & W IN NE COR) ALSO COMM SW COR OF NW1/4 RUN N 39.97 FT TO THE See Tax Roll For Extra Legal

Ad Valorem Taxes

Taxing Authority	Rate	Assessed Value	Exemption Amount	Taxable Value	Taxes Levied
BOARD OF COUNTY COMMISSIONERS	8.0150	54,712	24,712	\$30,000	\$240.45
COLUMBIA COUNTY SCHOOL BOARD DISCRETIONARY	0.7490	54,712	24,712	\$30,000	\$22.44
LOCAL	4.5040	54,712	24,712	\$30,000	\$135.12
CAPITAL OUTLAY	1.5000	54,712	24,712	\$30,000	\$45.00
SUWANNEE RIVER WATER MGT DIST	0.4093	54,712	24,712	\$30,000	\$12.28
LAKE SHORE HOSPITAL AUTHORITY	0.9620	54,712	24,712	\$30,000	\$28.86
Total Millage	16.1383		Total Taxes		\$484.15

Non-Ad Valorem Assessments

Code	Levying Authority	Amount
FFIR	FIRE ASSESSMENTS	\$237.06
GGAR	SOLID WASTE - ANNUAL	\$193.00

Total Assessments \$430.06
Taxes & Assessments \$914.21

If Paid By

Amount Due

\$0.00

Date Paid	Transaction	Receipt	Item	Amount Paid
3/20/2017	PAYMENT	1202059.0003	2016	\$914.21

Prior Years Payment History

Prior Year Taxes Due

NO DELINQUENT TAXES

A BOUNDARY SURVEY IN SECTION 22, TOWNSHIP 4 SOUTH,
RANGE 17 EAST, COLUMBIA COUNTY, FLORIDA.

DESCRIPTION:
A PART OF THE NW 1/4 OF SECTION 22, TOWNSHIP 4 SOUTH, RANGE 17 EAST, COLUMBIA COUNTY, FLORIDA, MORE PARTICULARLY DESCRIBED AS FOLLOWS: COMMENCE AT THE NW CORNER OF SAID SECTION 22 AND RUN N.88°39'02"E, ALONG THE NORTH LINE THEREOF, 1075.97 FEET; THENCE S.01°24'05"E, 104.98 FEET; THENCE N.88°35'10"E, 209.93 FEET TO THE WEST RIGHT-OF-WAY LINE OF COUNTY ROAD NO. 133; THENCE S.01°26'48"E, ALONG SAID RIGHT-OF-WAY LINE, 957.91 FEET TO THE POINT OF BEGINNING; THENCE CONTINUE S.01°26'48"E, 262.28 FEET; THENCE S.88°57'28"W, 333.82 FEET; THENCE N.01°26'48"W, 262.28 FEET; THENCE N.88°57'28"E, 333.82 FEET TO THE POINT OF BEGINNING, CONTAINING 2.01 ACRES, MORE OR LESS.

SUBJECT TO AN EASEMENT FOR INGRESS AND EGRESS OVER AND ACROSS THE SOUTH 30.00 FEET THEREOF BEING MORE PARTICULARLY DESCRIBED AS FOLLOWS:

AN EASEMENT FOR INGRESS AND EGRESS AS LIES 30.00 FEET TO THE RIGHT (NORTH) OF THE FOLLOWING DESCRIBED LINE:
COMMENCE AT THE NW CORNER OF SECTION 22, TOWNSHIP 4 SOUTH, RANGE 17 EAST, COLUMBIA COUNTY, FLORIDA, AND RUN N.88°39'02"E, ALONG THE NORTH LINE THEREOF, 1075.97 FEET; THENCE S.01°24'05"E, 104.98 FEET; THENCE N.88°35'10"E, 209.93 FEET TO THE WEST RIGHT-OF-WAY LINE OF COUNTY ROAD NO. 133; THENCE S.01°26'48"E, ALONG SAID RIGHT-OF-WAY LINE, 1220.59 FEET TO THE POINT OF BEGINNING OF SAID LINE; THENCE S.88°57'28"W, 333.82 FEET TO THE POINT OF TERMINATION OF SAID LINE. SAID EASEMENT IS TO EXTEND AND CONTRACT AS NEEDED TO CREATE THE BOUNDARIES THEREOF.

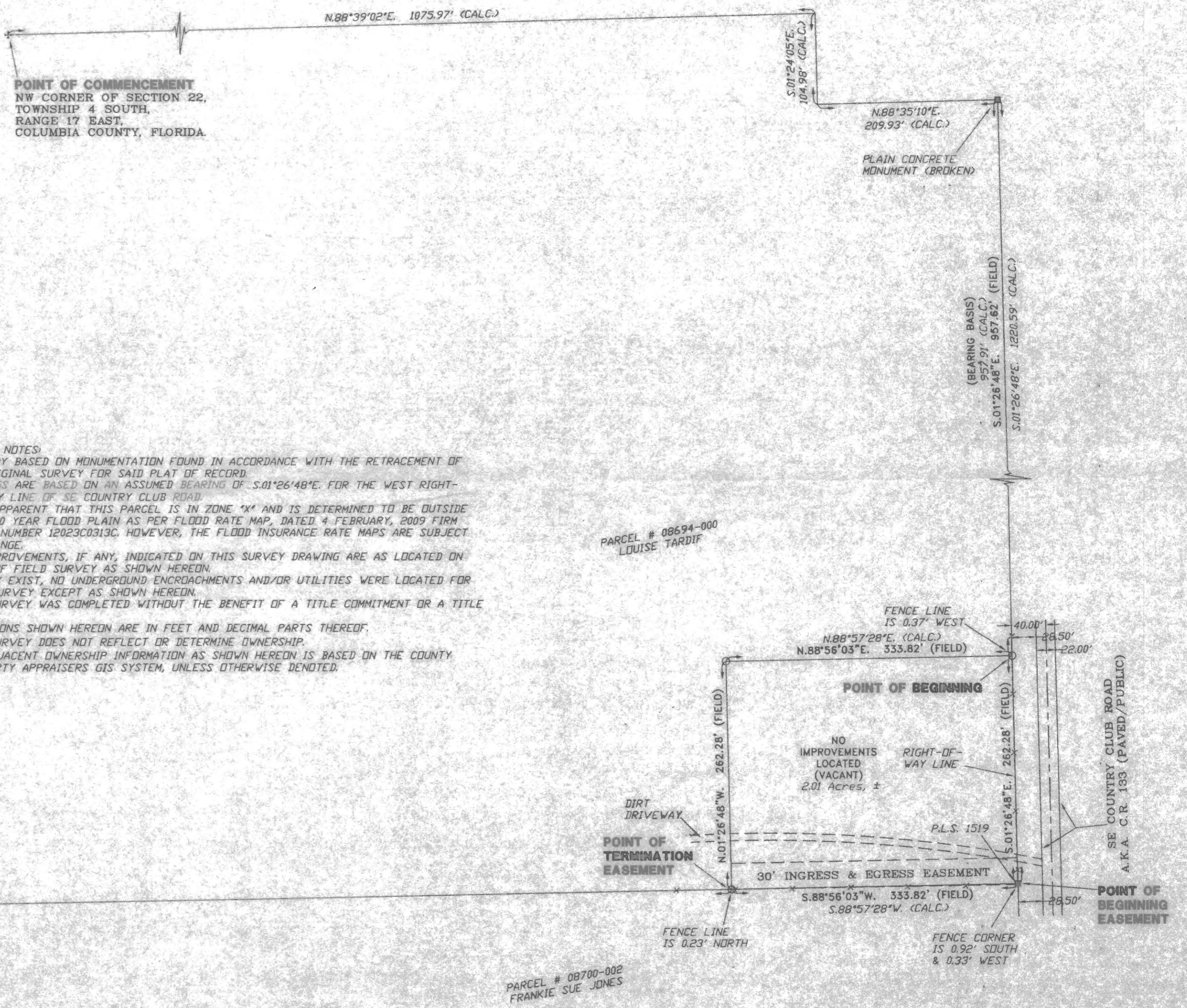

- SURVEYOR'S NOTES:**
- BOUNDARY BASED ON MONUMENTATION FOUND IN ACCORDANCE WITH THE RETRACEMENT OF THE ORIGINAL SURVEY FOR SAID PLAT OF RECORD.
 - BEARINGS ARE BASED ON AN ASSUMED BEARING OF S.01°26'48"E FOR THE WEST RIGHT-OF-WAY LINE OF SE COUNTRY CLUB ROAD.
 - IT IS APPARENT THAT THIS PARCEL IS IN ZONE "X" AND IS DETERMINED TO BE OUTSIDE THE 500 YEAR FLOOD PLAIN AS PER FLOOD RATE MAP, DATED 4 FEBRUARY, 2009 FIRM PANEL NUMBER 12023C0313C, HOWEVER, THE FLOOD INSURANCE RATE MAPS ARE SUBJECT TO CHANGE.
 - THE IMPROVEMENTS, IF ANY, INDICATED ON THIS SURVEY DRAWING ARE AS LOCATED ON DATE OF FIELD SURVEY AS SHOWN HEREIN.
 - IF THEY EXIST, NO UNDERGROUND ENCROACHMENTS AND/OR UTILITIES WERE LOCATED FOR THIS SURVEY EXCEPT AS SHOWN HEREIN.
 - THIS SURVEY WAS COMPLETED WITHOUT THE BENEFIT OF A TITLE COMMITMENT OR A TITLE POLICY.
 - DIMENSIONS SHOWN HEREON ARE IN FEET AND DECIMAL PARTS THEREOF.
 - THIS SURVEY DOES NOT REFLECT OR DETERMINE OWNERSHIP.
 - THE ADJACENT OWNERSHIP INFORMATION AS SHOWN HEREON IS BASED ON THE COUNTY PROPERTY APPRAISERS GIS SYSTEM, UNLESS OTHERWISE DENOTED.

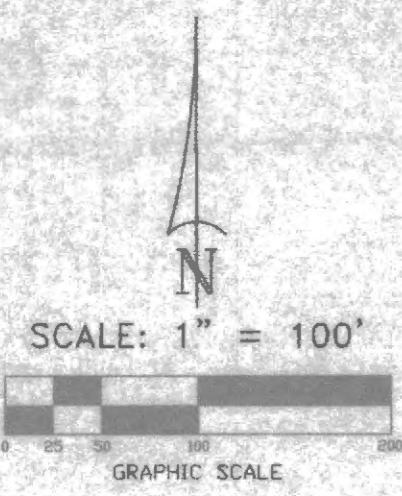

SYMBOL LEGEND:

■	4"x4" CONCRETE MONUMENT FOUND
□	4"x4" CONCRETE MONUMENT SET
○	IRON PIPE FOUND
●	IRON PIN AND CAP SET
x	"X" CUT IN PAVEMENT
+	CALCULATED PROPERTY CORNER
○	NAIL IN DIRT
⊙	POWER POLE
+	SIGN POST
+	WATER METER
⊙	UTILITY BOX
○	WELL
⊙	SANITARY MANHOLE
○	CENTERLINE
---	SECTION LINE
---	ELECTRIC LINES
---	VIRE FENCE
---	CHAIN LINK FENCE
---	WOODEN FENCE
(PLAT)	AS PER A PLAT OF RECORD
(DEED)	AS PER A DEED OF RECORD
(CALC.)	AS PER CALCULATIONS
(FIELD)	AS PER FIELD MEASUREMENTS
P.R.M.	PERMANENT REFERENCE MARKER
P.C.P.	PERMANENT CONTROL POINT

PL.S. 5757
S.88°56'03"W, 1328.62' (FIELD)

CERTIFIED TO:
BEVERLY STONE

SURVEYOR'S CERTIFICATION

I HEREBY CERTIFY THAT THIS SURVEY WAS MADE UNDER MY RESPONSIBLE CHARGE AND MEETS THE MINIMUM TECHNICAL STANDARDS AS SET FORTH BY THE FLORIDA BOARD OF PROFESSIONAL SURVEYORS AND MAPPERS IN CHAPTER 5J-17, FLORIDA ADMINISTRATIVE CODE, PURSUANT TO SECTION 472.02, FLORIDA STATUTES.

02/27/17 FIELD SURVEY DATE
03/18/17 DRAWING DATE

Scott Britt
SCOTT BRITT, P.S.M.
CERTIFICATION # 5757

NOTE: UNLESS IT BEARS THE SIGNATURE AND THE ORIGINAL RAISED SEAL OF A FLORIDA LICENSED SURVEYOR AND MAPPER THIS DRAWING, SKETCH, PLAT OR MAP IS FOR INFORMATIONAL PURPOSES ONLY AND IS NOT VALID.

FIELD BOOK: 354 PAGE(S): 50

PARCEL # 08700-002
FRANKIE SUE JONES

PARCEL # 08694-000
LOUISE TARDIF

BRITT SURVEYING & MAPPING, LLC



LAND SURVEYORS AND MAPPERS, L.B. # 8016
2086 SW MAIN BLVD, SUITE 112
LAKE CITY, FLORIDA 32025

www.brittsurvey.com
TELEPHONE: (386) 752-7163 FAX: (386) 752-5573 WORK ORDER # L-24586

C:\temp\124586.dwg Thu May 11 14:26:44 2017 Britt Surveying and Mapping, LLC (WAB)



6

**COLUMBIA COUNTY BOARD OF COUNTY COMMISSIONERS
AGENDA ITEM REQUEST FORM**

The Board of County Commissioners meets the 1st and 3rd Thursday of each month at 5:30 p.m. in the Columbia County School Board Administrative Complex Auditorium, 372 West Duval Street, Lake City, Florida 32055. All agenda items are due in the Board's office one week prior to the meeting date.

Today's Date: July 26, 2017 Meeting Date: August 3, 2017

Name: David Kraus Department: Fire and Rescue Dept

Division Manager's Signature: 

1. Nature and purpose of agenda item:

To authorize the application for a FY2017-18 Florida Firefighter Assistance Grant for \$45,000 to purchase Personal Protective Equipment for Reservists.

Attach any correspondence information, documents and forms for action i.e., contract agreements, quotes, memorandums, etc.

2. Fiscal impact on current budget.

Is this a budgeted item? N/A
 Yes Account No. _____
 No Please list the proposed budget amendment to fund this request

Budget Amendment Number: _____ Fund: _____

FROM: _____ TO: _____ AMOUNT: _____

For Use of County Manger Only:

Consent Item Discussion Item

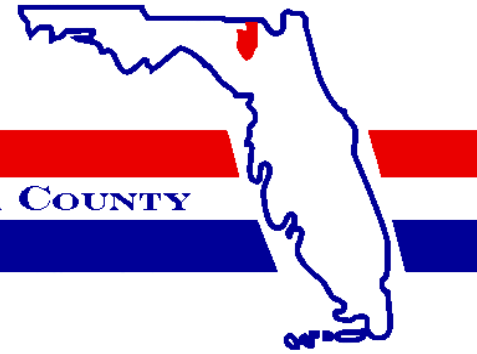

BOARD OF COUNTY COMMISSIONERS • COLUMBIA COUNTY

MEMORANDUM

DATE: July 26, 2017

TO: Columbia County Board of County Commissioners

FR: David Kraus, Risk manager 

RE: Application for Florida Firefighter Assistance Grant

The Florida Department of Financial Services Division of State Fire Marshall has issued a Notice of Funding Opportunity for the FY2017-2018 Florida Firefighter Assistance Grant Program. Applications are due no later than August 11, 2017. This grant requires no matching funds.

The Firefighter Assistance Grant Program was established by Florida Statute 633.135 and F.A.C. 69A-37.502 to improve the emergency response capability of volunteer fire departments and combination fire departments. This program provides financial assistance to improve firefighter safety and enable such fire departments to provide firefighting, emergency medical, and rescue services to their communities. Grant funding is available for training, PPE, SCBA's, and cost share subsidy for AFG apparatus awards. \$1,000,000 is available statewide.

The Columbia County Fire and Rescue Department plans to apply for this grant to address the PPE gear needs of 17 active volunteer/reservist firefighters. The County provides both personal protective equipment (PPE) and for all of the paid firefighters but has not funded this equipment for the reservists. Currently these firefighters are outfitted with used equipment that has been patched and is near or exceeding the manufacturers recommended useful life. A set of turnout gear will cost \$2,400. This grant would provide the funding to acquire the PPE and SCBA for the current 17 volunteers.

The Fire and Rescue Department is requesting the Columbia County Board of County Commissioners authorize an application to the Florida Firefighters Assistance Grant Program for up to \$45,000.



7

COLUMBIA COUNTY BOARD OF COUNTY COMMISSIONERS
AGENDA ITEM REQUEST FORM

The Board of County Commissioners meets the 1st and 3rd Thursday of each month at 5:30 p.m. in the Columbia County School Board Administrative Complex Auditorium, 372 West Duval Street, Lake City, Florida 32055. All agenda items are due in the Board's office one week prior to the meeting date.

Today's Date: July 25, 2017 Meeting Date: August 3, 2017

Name: Lisa Roberts Department: Human Resources

Division Manager's Signature: [Handwritten Signature]

1. Nature and purpose of agenda item:

Department of the Navy - National Naval Aviation Museum Aircraft Loan Agreement Amendment

Attach any correspondence information, documents and forms for action i.e., contract agreements, quotes, memorandums, etc.

2. Fiscal impact on current budget.

Is this a budgeted item? [X] N/A [] Yes Account No. [] No Please list the proposed budget amendment to fund this request

Budget Amendment Number: Fund:

FROM: TO: AMOUNT:

For Use of County Manger Only:

[X] Consent Item [] Discussion Item

District No. 1 - Ronald Williams
District No. 2 - Rusty DePratter
District No. 3 - Bucky Nash
District No. 4 - Everett Phillips
District No. 5 - Tim Murphy



BOARD OF COUNTY COMMISSIONERS • COLUMBIA COUNTY

MEMORANDUM

TO: Board of County Commissioners

FROM: Lisa K.B. Roberts, Human Resources Director *LKR*

DATE: July 25, 2017

SUBJECT: Department of the Navy –
National Naval Aviation Museum Aircraft Loan Agreement Amendment

Attached you will find a letter dated July 11, 2017 from the Department of Navy in which they are notifying Borrowers of National Naval Aviation Museum (NNAM) aircraft of an amendment to the respective Borrowers current loan agreement.

As you are aware, Columbia County entered into a Standard Renewal Loan Agreement on January 4, 2017 for the A-7E Corsair II aircraft, which is loaned to the Columbia County Board of County Commissioners from the National Naval Aviation Museum (NNAM) at Pensacola, Florida.

The attached letter is serving notice of the amendment to the Standard Renewal Loan Agreement which would prohibit the access and entering of aircraft cockpits by the General Public. Walk-ups/ladders to the aircraft cockpits may be allowed in order for the visitor to view the cockpit interior, as long as the cockpit interior is not accessible and that the Borrower has made every attempt to ensure visitor safety.

Additionally, relocation of loaned property for temporary special events (parades, ceremonies, air shows, etc.) is not authorized under any circumstances, without prior expressed written consent of the NNAM. No temporary decorations of any type are authorized to be displayed on any loaned property, for any purpose (special event, seasonal display, ceremonies, etc.).

Only historically based markings, including crew member names, may be used on aircraft and other navy owned equipment and the agreement precludes the use of markings on the equipment for commercial, fundraising, or sponsorship purposes. The Borrower shall obtain expressed written consent from the Lender PRIOR to painting any markings or insignia onto aircraft, especially with respect to names being applied to aircraft. Failure to observe these conditions can result in the immediate repossession of the loaned property by NNAM, at the Borrower's expense.

NNAM is requesting the Board acknowledge the loan agreement revisions as well as abiding by its conditions by signing the letter and returning the acknowledgement to NNAM.

BOARD MEETS FIRST THURSDAY AT 5:30 P.M.
AND THIRD THURSDAY AT 5:30 P.M.

MEMORANDUM
July 25, 2017
Page Two

Therefore, your approval of the loan agreement amendment is requested.
If you have any questions, please feel free to contact me at (386) 758-1006. Thank you for your consideration of the above stated request.

XC: Ben Scott, County Manager
Scott Ward, Assistant County Manager
Vernon Douglas
Standard Renewal Loan Agreement A-7E Corsair II Aircraft File



**DEPARTMENT OF THE NAVY
 NATIONAL NAVAL AVIATION MUSEUM
 1750 RADFORD BLVD
 SUITE C
 PENSACOLA FLORIDA 32508-5402**

5002
 Ser N00: 1 35
 JUL 1 1 2017

To the Borrowers of National Naval Aviation Museum (NNAM) aircraft

For the reasons of aircraft preservation and, most importantly, public safety, NNAM prohibits the access and entering of aircraft cockpits by the General Public. Walk-ups ladders to the aircraft cockpits may be allowed in order for the visitor to view the cockpit interior, as long as the cockpit interior is not accessible and that the Borrower has made every attempt to ensure visitor safety. This proviso does not include cockpit simulator exhibits.

Additionally, relocation of all loaned property for temporary special events (parades, ceremonies, air shows, etc.) is not authorized under any circumstances, without prior expressed written consent of the NNAM. No temporary decorations of any type are authorized to be displayed on any loaned property, for any purpose (special event, seasonal display, ceremonies, etc.).

Only historically based markings, including crewmember names, may be used on aircraft and other navy owned equipment and this agreement precludes the use of markings on this equipment for commercial, fundraising, or sponsorship purposes. The Borrower shall obtain expressed written consent from the Lender PRIOR to painting any markings or insignia onto aircraft, especially with respect to names being applied to aircraft. Failure to observe these conditions can result in the immediate repossession of the loaned property by NNAM, at the Borrower's expense.

This letter shall serve as notice and immediate amendment to all current loan agreements between the Borrower and the NNAM. Please sign below where indicated and return the acknowledgement to NNAM by any of the following methods:

- Fax: 1-850-452-3296
- Email: Lenore.taylor@navy.mil
- USPS: National Naval Aviation Museum
- 1750 Radford Blvd., Suite C
 NAS Pensacola, FL 32508

Thank you and if you have any questions or concerns regarding these loan amendment requirements, please contact my Aircraft Loan Manager, Ms. Lenore Taylor at: email Lenore.taylor@navy.mil or 850-452-3604 ext 3133.

Sincerely,

STERLING G. GILLIAM
 Captain, USN (Ret.)
 Director

I acknowledge the foregoing loan agreement amendment and agree to abide by its conditions:

 PRINTED NAME TITLE ORGANIZATION SIGNATURE DATE



8

COLUMBIA COUNTY BOARD OF COUNTY COMMISSIONERS AGENDA ITEM REQUEST FORM

The Board of County Commissioners meets the 1st and 3rd Thursday of each month at 5:30 p.m. in the Columbia County School Board Administrative Complex Auditorium, 372 West Duval Street, Lake City, Florida 32055. All agenda items are due in the Board's office one week prior to the meeting date.

Today's Date: July 24, 2017 Meeting Date: August 3, 2017

Name: Kevin Kirby Department: Public Works

Division Manager's Signature: 

1. Nature and purpose of agenda item:

Utility permit from AT&T for the purpose of placing 1219' of fiber cable @ 30" min depth and boring under CR 245@ 48" min depth.

Attach any correspondence information, documents and forms for action i.e., contract agreements, quotes, memorandums, etc.

2. Fiscal impact on current budget.

Is this a budgeted item? N/A
 Yes Account No. _____
 No Please list the proposed budget amendment to fund this request

Budget Amendment Number: _____ Fund: _____

FROM: _____ TO: _____ AMOUNT: _____

For Use of County Manger Only:

Consent Item Discussion Item

AT&T JOB #:73E61217N

COLUMBIA COUNTY BOARD OF COUNTY COMMISSIONERS
UTILITY PERMIT

Date: 7-20-17 Permit No. _____ County Road 245 Section No. _____

Permittee At&t Authorized Agent Rebecka Bonts Email: RBonts@truenetcommunications.com
Address 7666 Blanding Blvd. Jacksonville, FL 32244 Telephone Number 904-777-9052 ext.258

Requesting permission from the Columbia County Board of County Commissioners, hereinafter called the County, to contract, operate and maintain: At&t proposes to place 1219' of fiber cable @ 30" min depth and boring under CR 245 @ 48" min depth.

Submitted for the Utility Owner by: Rebecka Bonts AT&T Authorized Agent
Typed Name & Title Signature Date

1. Permittee declares that prior to filing this application it has determined the location of all existing utilities, both aerial and underground and the accurate locations are shown on the plans attached hereto and made a part of this application. Proposed work is within the corporate limits of Municipality: YES () NO (x). If YES: LAKECITY () FORT WHITE (). A letter of notification was mailed on 7-20-17 to the following utility owners: Columbia Co. utilities

2. The Columbia County Public Works Director shall be notified twenty-four (24) hours prior to starting work and again immediately upon completion of work. The Public Works Director is Kevin Kirby, located at P.O. Box 969, Lake City, FL 32056 Telephone Number (386) 752-5955. The PERMITTEE's employee responsible for Maintenance of Traffic is Mike Brown, Telephone Number (352) 336-5508 (This name may be provided at the time of the 24 hour notice to starting work).

3. This PERMITTEE shall commence actual construction in good faith within _____ days after issuance of permit, and shall be completed within _____ days after permitted work has begun. If the beginning date is more than 60 days from date of permit approval, then PERMITTEE must review the permit with the Columbia County Public Works Director to make sure no changes have occurred in the transportation facility that would affect the permitted construction.

4. The construction and maintenance of such utility shall not interfere with the property and rights of a prior PERMITTEE.

5. It is expressly stipulated that this permit is a license for permissive use only and that the placing of utilities upon public property pursuant to this permit shall not operate to create or vest any property right in said holder.

6. Pursuant to Section 337.403(1), Florida Statutes, whenever necessary for the construction, repair, improvement, maintenance, safe and efficient operation, alteration or relocation of all, or any portion of said transportation facility as determined by the Columbia County Public Works Director and/or County Engineer, any or all utilities and appurtenances authorized hereunder, shall be immediately removed from said transportation facility or reset or relocated thereon as required by the Columbia County Public Works Director and/or County Engineer and at the expense of the PERMITTEE.

Utilities Permit
Revised: 08-28-00

7. In case of non-compliance with the County's requirements in effect as of the approval date of this permit, this permit is void and the facility will have to be brought into compliance or removed from the right of way at no cost to the County.

8. It is understood and agreed that the rights and privileged herein set out are granted only to the extent of the County's right, title and interest in the land to be entered upon and used by the PERMITTEE, and the PERMITTEE will, at all times, and to the extent permitted by law, assume all risk of and indemnify, defend, and save harmless the Columbia County Board of County Commissioners from any and all loss, damage, cost or expense arising in any manner on account of the exercise or attempted exercise by said PERMITTEE of the aforesaid right and privileges.

9. During construction, all safety regulations of the County shall be observed and the PERMITTEE must take measures, including placing and the display of safety devices that may be necessary in order to safely conduct the public through the project area in accordance with the Federal Manual on the Uniform Traffic Control Devices, as amended for highways.

10. Should the PERMITTEE be desirous of keeping its utilities in place and out of service, the PERMITTEE, by execution of this permit acknowledges its present and continuing ownership of its utilities located between _____ and _____ within the County's right of way as set forth above. PERMITTEE, at its sole expense, shall promptly remove said out of service utilities whenever Columbia County Public Works Director and/or County Engineer determines said removal is in the public interest.

11. Special instruction: Minimum cover of thirty inches (30") will be required at all locations. Columbia County will not be financially responsible for any damage to facilities with less than thirty inch (30") cover. Cables shall not be located within driveway ditches.

12. Additional Stipulations: _____

It is understood and agreed that commencement by the PERMITTEE is acknowledgment and acceptance of the binding nature of these special instructions.

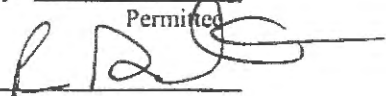
Submitted By: Rebecka Bonts
Permitted
Signature 

Place Corporate Seal
Title: AT&T Authorized Agent

Attest

Recommended for Approval

Signature: [Signature]

Title : ASS County Manager

Date : 07-24-17

Approved by Columbia County Board of County Commissioners:

YES () NO ()

Date Approved: _____

Chairman's Signature: _____

JUL 21 2017
[Signature]

VICINITY SKETCH

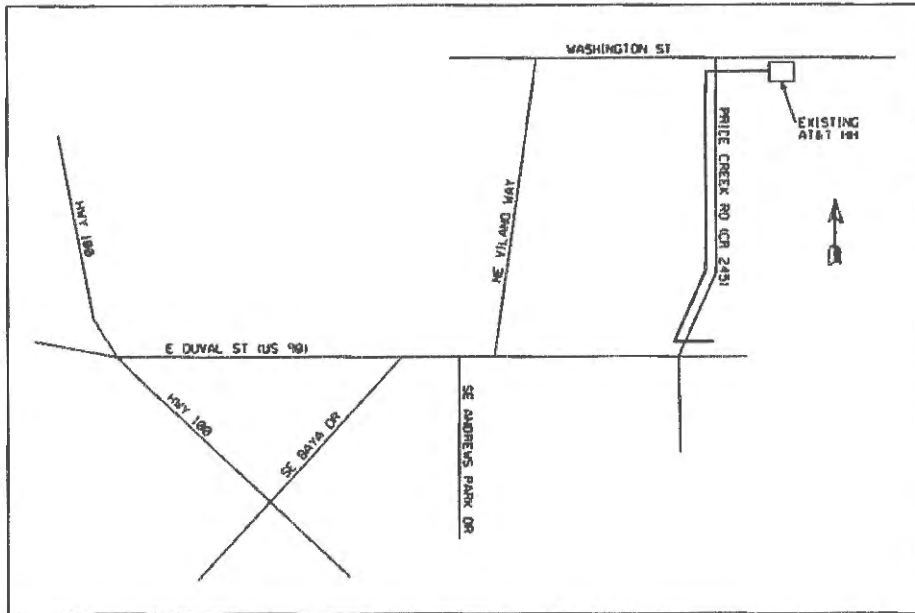

PERMIT NOTES:

AT&T PROPOSES TO PLACE THE FOLLOWING TELEPHONE FACILITIES:

1219 ft OF BURIED FIBER CABLE IN THE WEST RIGHT-OF-WAY OF PRICE CREEK RD (CR 245) AT A DEPTH OF 30".

PLACEMENT WILL REQUIRE TWO ROADWAY BORES.

PRIMARY METHOD OF PLACEMENT WILL BE MECHANICALLY PLACED, UNLESS NOTED OTHERWISE.



CONTACT INFORMATION:

AT&T BUILD SUPERVISOR:
BYRON BARNARD (352) 336-5544 (office)

AT&T FACILITIES INSTALLER (CONTRACTOR):
DANELLA CONSTRUCTION CORP. OF FLORIDA, INC.

SATALIG@DANELLA.COM

NOTE TO PERMITTING AGENCY:

THE BELOW INFORMATION IS THE ORIGINAL DRAFT PERSON WHO HAS DETAILED FIELD KNOWLEDGE OF THE PROPOSED WORK TO BE PERFORMED ON THIS PERMIT REQUEST, AND SHOULD BE THE FIRST POINT OF CONTACT WITH QUESTIONS TO THIS PERMIT REQUEST.

DESIGNER: STEPHEN CLARK (904) 413-1011
PROJECT MGR: MIKE WALTERS (904) 777-9052 x243

MAINTENANCE OF TRAFFIC

WORKERS WILL UTILIZE M.O.T. CASE #602 FOR THE PROPOSED WORK SHOWN THROUGHOUT THESE DRAWINGS.

SYMBOL LEGEND

Proposed	Existing	Description
		AERIAL CABLE
		BURIED CABLE
		BUR JOINT-TRENCH
		BST POLE
		POWER POLE
		ANCHOR & CUY
		PUSH BRACE
		ENCLOSURE
		ENCLOSURE
		MANHOLE
		PIPE/CONDUIT
		CABLE MARKER
		AERIAL SVC WIRE
		BURIED SVC WIRE
		JOINT-TRENCH SVC
	N/A	BORE
	N/A	CUT PAVEMENT
	N/A	SPLICING PIT
	N/A	TRENCH LENGTH

ATTSE

PROPOSED TELEPHONE FACILITIES ON RIGHT OF WAY OF COLUMBIA COUNTY

CR 245

Exchange: 386752

Designer: Fernandez, Chris

Phone: 904-727-1554

Authorization: 73E61217N

Dwg. 1 of 4

- ⑥ EXISTING AT&T BURIED FIBER CABLE
- ⑫ EXISTING AT&T BURIED COPPER CABLE
- ⑬ EXISTING AT&T BURIED COPPER CABLE
- ⑭ PROPOSED AT&T BURIED FIBER CABLE
- ⑮ EXISTING AT&T BURIED COPPER CABLE
- ⑰ EXISTING AT&T BURIED COPPER CABLE
- ⑱ EXISTING AT&T BURIED COPPER CABLE
- ⑲ EXISTING AT&T BURIED COPPER CABLE
- ⑳ EXISTING AT&T BURIED COPPER CABLE
- ㉑ EXISTING AT&T BURIED COPPER CABLE
- ㉒ EXISTING AT&T BURIED COPPER CABLE
- ㉓ EXISTING AT&T BURIED COPPER CABLE
- ㉔ PROPOSED 2" CONDUIT
- ㉕ PROPOSED 2" CONDUIT

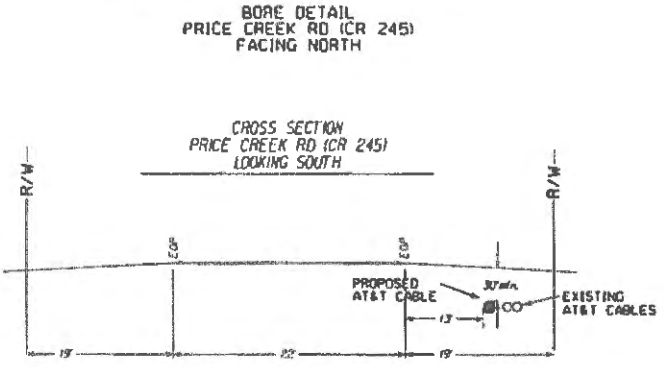
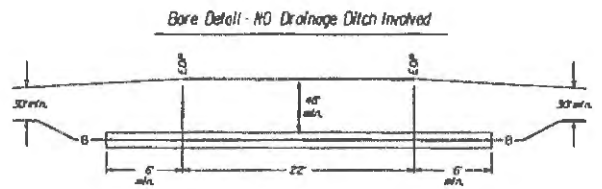
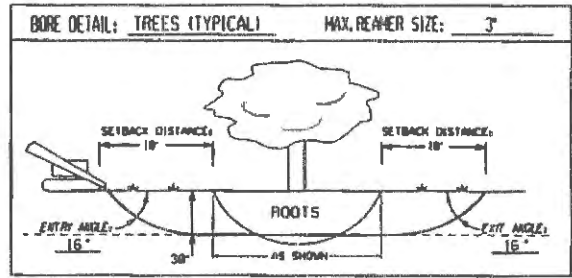
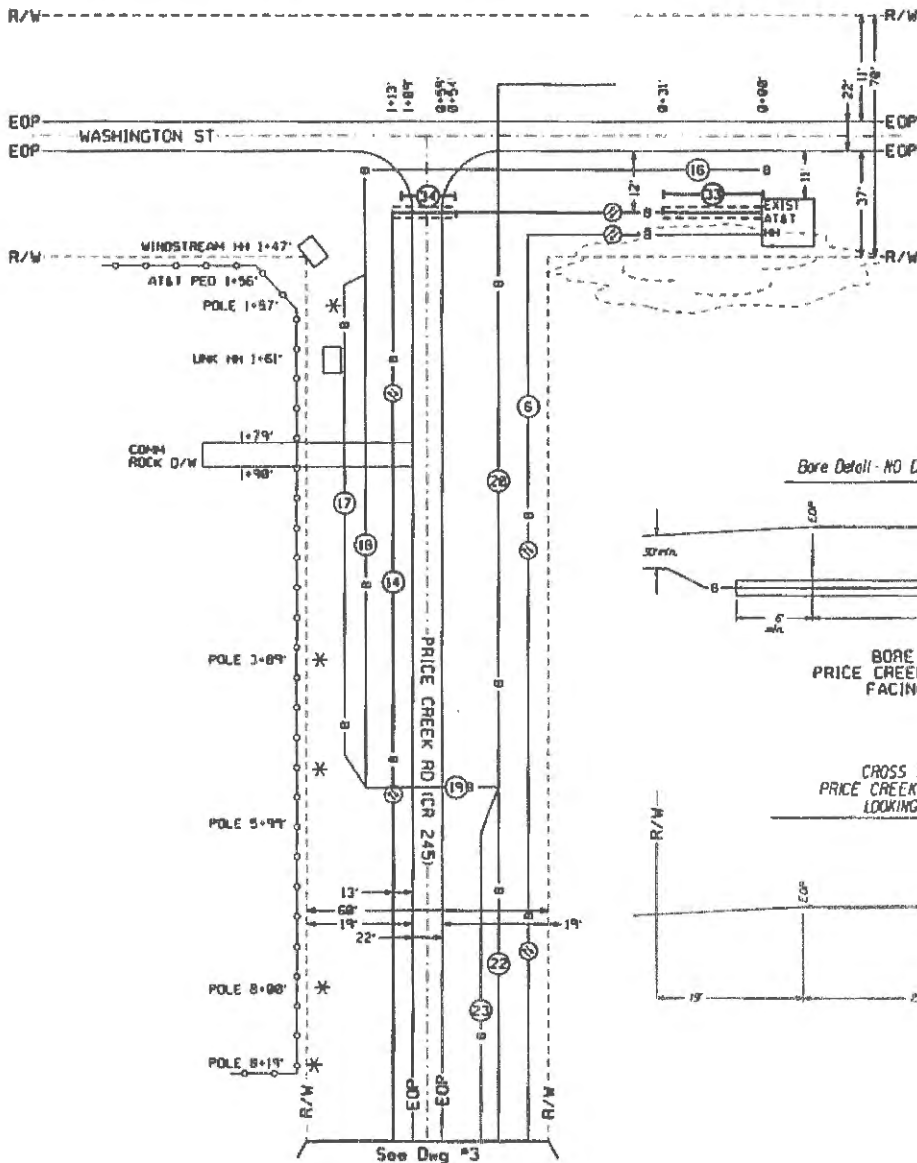

ATTSE	
PROPOSED TELEPHONE FACILITIES ON RIGHT OF WAY OF COLUMBIA COUNTY	
CR 245	
Exchange:	386752
Designer:	Fernandez, Chris
Phone:	904-727-1554
Authorization:	73E6127N
Dwg.:	2 of 4



ATTSE	
PROPOSED TELEPHONE FACILITIES ON RIGHT OF WAY OF COLUMBIA COUNTY	
Exchange:	CR 245
Designer:	386752
	Fernandez, Chris
Phone:	904-727-1554
Author/Date:	73E6217N
Dep. <u> 3 </u> of <u> 4 </u>	

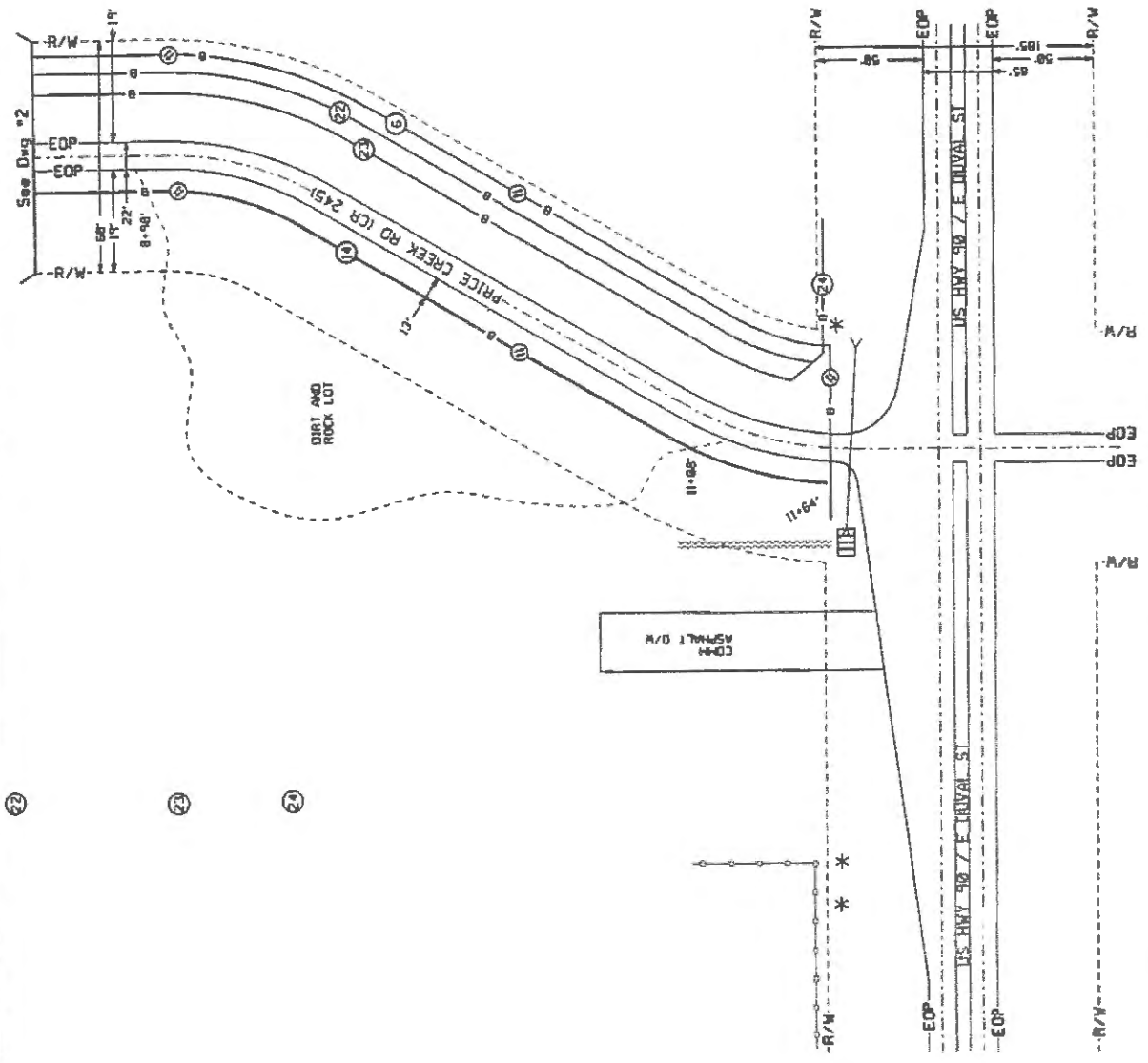

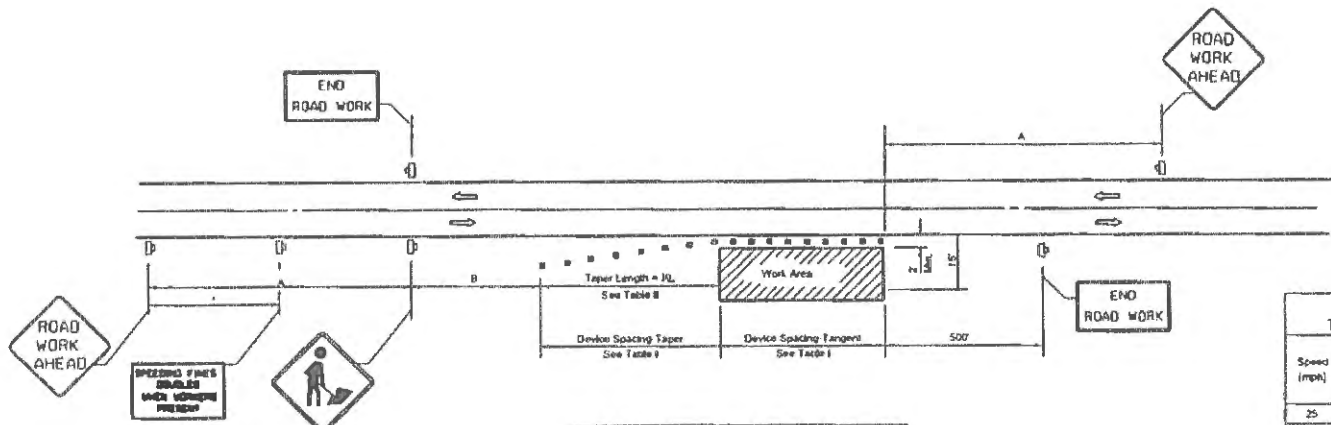

DISTANCE BETWEEN SIGNS

Speed	Spacing (ft.)	
	A	B
40 mph or less	200	200
45 mph	350	350
50 mph or greater	500	500

A=distance between signs

**Table I
Device Spacing**

Speed (mph)	Max. Distance Between Devices (ft.)			
	Cones or Tubular Markers		Type I or Type II Barricades or Vertical Panels or Drums	
	Taper	Tangent	Taper	Tangent
25	25	50	25	50
30 to 45	25	50	30	50
50 to 70	25	50	50	100

**Table II
Taper Length - Shoulder**

Speed (mph)	XL (ft)			Notes
	8' Shld.	10' Shld.	12' Shld.	
25	25	35	42	L = WS' / 60
30	40	50	60	
35	55	68	82	
40	72	90	107	L = WS
45	120	150	180	
50	135	167	200	
55	147	183	220	
60	160	200	240	
65	173	217	260	
70	187	233	280	

8' = minimum shoulder width
 XL = Length of shoulder taper in feet
 W = Width of total shoulder in feet (concrete paved and unpaved width)
 S = Posted speed limit (mph)

- SYMBOLS**
- Work Area
 - Channelizing Device (See Index No. 660)
 - Work Zone sign
 - Lane Identification + Direction of Traffic

- GENERAL NOTES**
- When four or more work vehicles enter the through traffic lanes in a one hour period or less (including establishing and terminating the work area), the advanced FLASHER sign shall be substituted for the WORKERS sign. For location of flaggers and FLAGGER signs, see Index No. 803.
 - SHOULDER WORK sign may be used as an alternate to the WORKER symbol sign only on the side where the shoulder work is being performed.
 - When a side road intersects the highway within the TTC zone, additional TTC devices shall be placed in accordance with other applicable TCZ indexes.
 - For general TCZ requirements and additional information, refer to Index No. 600.

- DURATION NOTES**
- Signs and channelizing devices may be omitted if all of the following conditions are met:
 - Work operations are 60 minutes or less.
 - Vehicles in the work area have high-intensity rotating, flashing, oscillating, or strobe lights operating.

CONDITIONS
 WHERE ANY VEHICLE, EQUIPMENT WORKERS OR THEIR ACTIVITIES ENCRoACH THE AREA CLoSER THAN 15' BUT NOT CLoSER THAN 2' TO THE EDGE OF TRAVEL WAY

ATTSE	
PROPOSED TELEPHONE FACILITIES ON RIGHT OF WAY OF COLUMBIA COUNTY	
CR 245	
Exchange:	386752
Designer:	Fernandez, Chris
Phone:	904-727-1554
Authorizator:	73E6217N
Req.:	4 of 4



9

COLUMBIA COUNTY BOARD OF COUNTY COMMISSIONERS AGENDA ITEM REQUEST FORM

The Board of County Commissioners meets the 1st and 3rd Thursday of each month at 5:30 p.m. in the Columbia County School Board Administrative Complex Auditorium, 372 West Duval Street, Lake City, Florida 32055. All agenda items are due in the Board's office one week prior to the meeting date.

Today's Date: July 28, 2017 Meeting Date: August 3, 2017

Name: Kevin Kirby Department: Public Works

Division Manager's Signature: 

1. Nature and purpose of agenda item:

Utility permit from FP&L on CR 252.

Attach any correspondence information, documents and forms for action i.e., contract agreements, quotes, memorandums, etc.

2. Fiscal impact on current budget.

Is this a budgeted item? N/A
 Yes Account No. _____
 No Please list the proposed budget amendment to fund this request

Budget Amendment Number: _____ Fund: _____

FROM: _____ TO: _____ AMOUNT: _____

For Use of County Manger Only:

Consent Item Discussion Item

COLUMBIA COUNTY BOARD OF COUNTY COMISSIONERS
UTILITY PERMIT

Date: 7/24/17 Permit No. _____ County Road _____ Section No. _____

Permittee Florida Power & Light

Address 9001 Ellis Rd., Melbourne, FL 32904 Telephone Number 321-726-4867

Requesting permission from Columbia County, Florida, hereinafter called the County, to contract, operate and maintain Install 2 proposed Splice boxes

Located Along County Rd 252, Eadesn Rd, Starling St, Pinemount Rd, Marics Rd and Litteray Rd MOT 603 & 605

FROM: _____ TO: _____

Submitted for the Utility Owner by: Melissa Slyter-Prmt Admn. Melissa Slyter 7/24/2017
Typed Name & Title Signature Date

1. Permittee declares that prior to filing this application it has determined the location of all existing utilities, both aerial and underground and the accurate locations are shown on the plans attached hereto and made a part of this application. Proposed work is within corporate limits of Municipality: YES () NO (). If YES: LAKE CITY () FORT WHITE (). A letter of notification was mailed on _____ to the following utility owners _____

2. The Columbia County Public Works Director shall be notified twenty-four (24) hours prior to starting work and again immediately upon completion of work. The Public Works Director is _____, located at _____ Telephone Number _____. The PERMITTEE's employee responsible for Maintenance of Traffic is _____ Telephone Number _____ (This name may be provided at the time of the 24 hour notice to starting work.)

3. This PERMITTEE shall commence actual construction in good faith within ___ days after issuance of permit, and shall be completed within 180 days after permitted work has begun. If the beginning date is more than 60 days from date of permit approval, then PERMITTEE must review the permit with the Columbia County Public Works Director to make sure no changes have occurred in the transportation facility that would affect the permitted construction.

4. The construction and maintenance of such utility shall not interfere with the property and rights of a prior PERMITTEE.

5. It is expressly stipulated that this permit is a license for permissive use only and that the placing of utilities upon public property pursuant to this permit shall not operate to create or vest any property right in said holder.

6. Pursuant to Section 337-403(1), Florida Statutes, whenever necessary for the construction, repair, improvement, maintenance, safe and efficient operation, alteration or relocation of all, or any portion of said transportation facility as determined by the Columbia County Public Works Director and/or County Engineer, any or all utilities and appurtenances authorized hereunder, shall be immediately removed from said transportation facility or reset or

relocated thereon as required by the Columbia County Public Works Director and/or County Engineer and at the expense of the PERMITTEE.

7. In case of non-compliance with the County's requirements in effect as of the approval date of this permit, this permit void and the facility will have to be brought into compliance or removed from the right of way at no cost to the County.

8. It is understood and agreed that the rights and privileges herein set out are granted only to the extent of the County's right, title and interest in the land to be entered upon and used by the PERMITTEE, and the PERMITTEE will, at all times, and to the extent permitted by law, assume all risk of and indemnify, defend, and save harmless Columbia County, Florida from any and all loss, damage, cost or expense arising in any manner on account of the exercise or attempted exercise by said PERMITTEE of the aforesaid right and privileges.

9. During construction, all safety regulations of the County shall be observed and the PERMITTEE must take measures, including pacing and the display of safety devices that may be necessary in order to safely conduct the public through the project area in accordance with the Federal Manual on Uniform Traffic Control Devices, as amended for highways.

10. Should the PERMITTEE be desirous of keeping its utilities in place and out of service, the PERMITTEE, by execution of this permit acknowledges its present and continuing ownership of its utilities located between _____ and _____ within the County's right of way as set forth above. PERMITTEE, as its sole expense, shall promptly remove said out of service utilities whenever Columbia County Public Works Director and/or County Engineer determines said removal is in the public interest.

11. Special instructions: Minimum cover of thirty inches (30") will be required at all locations. Columbia County will not be financially responsible for any damage to facilities with less than thirty inches (30") cover. Cables shall not be located within driveway ditches.

12. Additional Stipulations: _____

It is understood and agreed that commencement by the PERMITTEE is acknowledgment and acceptance of the binding nature of these specialist instructions.

Submitted By: Melissa Slyter
Permittee

Place Corporate Seal

Melissa Slyter
Signature and Title Permit Admin.

Attested

Utilities Permit
Page three
Revised: 8/17/00

Recommended for Approval:

Signature: 
Title: Asst County Manager
Date: 07-27-17

Approval by Board of County Commissioners, Columbia County, Florida:

YES () NO ()

Date Approved: _____

Chairman's Signature: _____

JUL 27 2017
Handwritten initials

COVER PAGE FOR WR#7723700

REPLACE ALL POLES AND
TRANSFER/REPL ALL FPL
FACILITIES AS REQUIRED

[] INACCESSIBLE

[X] 13KV

[] FUTURE 23KV

[] 23KV

[] SALT SPRAY

[] ROCK

Location: 1 POLE W/O S.W. JOYFUL LP ON PINEMOUNT RD.		Substation: NASH	Feeder: 06132
	Inspection Date: 05/03/2016 11:31:00		Remarks: Other Pole Conditions: shell rot no deduction. Owner: fpl distribution. Accessibility: accessible by line truck. Previous Cycle Info: groundline treatment, woodfume. Year Last Treated: 2008. Last Treated By: osmose. Other Pole Types: feeder, IWR Number: 6769334. WR Number: d00006769334. Length/Class: actual.
	Management Area: NORTH FLORIDA		
	County: COLUMBIA		
	Franchise Name: COLUMBIA		
	BST Wire Center: LC - LAKE CITY		
	Pole ID: 1879742		
	Manufacturer: OTH		
	Existing Pole Height: 40		
	Existing Pole Class: 5		
	X: -82.72028200 Y: 30.17087700		
Unique ID: 343271711		FRAME PER DCS E-25.0.0 FIG 1	



MOT 605

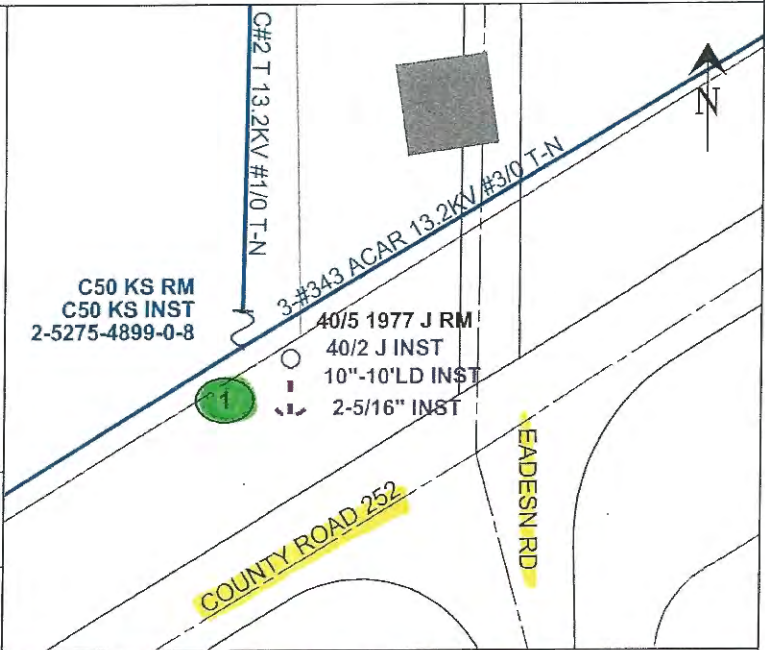
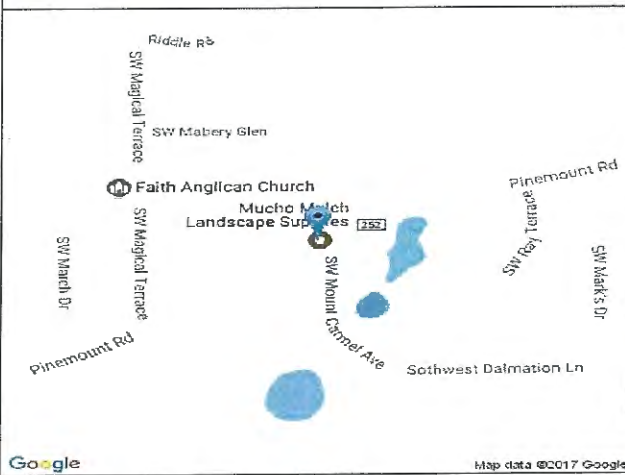

Feet of ground rod installed _____
 Ground Resistance (Ohms) _____

American Disabilities Act
 If pole placement location does not meet the minimum single point distance of 32" from edge of curb or back of sidewalk, contact your Production Lead, for further instructions.

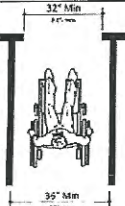

PLEASE BE ADVISED THAT RECEIPT OF THIS DRAWING AND/OR SURVEY, WHICH IS AN APPROXIMATION, DOES NOT RELIEVE YOU OF ANY STATUTORY OBLIGATIONS, INCLUDING THE PROVISIONS CONTAINED IN SECTION 556, FLORIDA STATUTES. CALL 811 (Sunshine811) PRIOR TO ANY EXCAVATION ACTIVITIES

Replace existing wood with proposed wood

AS-BUILT CREW PRINT

ALL REQUIRED GROUND RODS HAVE BEEN DRIVEN & VERIFIED TO BE WITHIN FPL STANDARDS. VALUES ARE SHOWN AT ALL LOCATIONS.

JOB CERTIFIED COMPLETED AS SHOWN ON THIS AS-BUILT PRINT. MATERIAL CHANGES SHOWN ON ROS.

AS-BUILT COPY

Foreman's Signature _____ Date _____

Foreman's Signature _____ Date _____

Supervisor's Signature _____ Date _____

Initials _____ Cert. Date _____

Easement? []	Tree Work? []	Tree Access? []	Tree Staking Req'd? []	FPL	M/A: NF	Township: 04 Range: 16 Section 04
Designer/Stake? []	CT/Special Mtr? []	Work with SMO? []	Survey/Stake? []	2016 PI - Pole Replacement Program		
PERMIT REQ'D	CITY []	COUNTY RD [X]	COUNTY AIR []	STATE RD []	FAA []	F6132 11 NASH SUB., LAKE CITY, 32024
	WMD []	RR XING []	DR. DIST. []	TRANSM. []		Job Owner: Jeffrey Corder Date: 07/24/2017
Requested Tel. Co. Set Poles? []		Tele. Attachment Per _____		Designer: Shaun Herring	Dwg No. 7723700_8x11 PIP2.xml	
Requested Tel. Co. Transfer? []				Scale: 1" = 50'	0' 50' 100'	
Request CATV Transfer? [X]				Map No. LF1138		
POLE LINE FT:		DUCT BANK FT:		WR: 7723700		
POLE LINE FT. ON TRANSM. POLES:		TRENCH FT:			Page 2 of 12	

Size: 8 x 11

PRINTED BY: SXH02LW

PLOT DATE/TIME: 07/24/2017 13:21:40

[] INACCESSIBLE

[X] 13KV

[] FUTURE 23KV

[] 23KV

[] SALT SPRAY

[] ROCK

Location: C/O S.W. PINEMOUNT RD. AND S.W. DEPUTY J DAVIS LN.

Substation: NASH

Feeder: 06132



Inspection Date: 05/02/2016 10:29:00

Management Area: NORTH FLORIDA

County: COLUMBIA

Franchise Name: COLUMBIA

BST Wire Center: LC - LAKE CITY

Pole ID: 1882724

Manufacturer: UNK

Existing Pole Height: 40

Existing Pole Class: 5

X: -82.71091200

Y: 30.17421500

Unique ID: 343271903

Remarks: Owner: fpl distribution. Accessibility: accessible by line truck. Previous Cycle Info: groundline treatment. Year Last Treated: 2008. Last Treated By: osmose. Other Pole Types: feeder. IWR Number: 6769334. WR Number: d00006769334. Length/Class: estimate.

FRAME PER DCS I-42.0.0 FIG 1
REPL C-15 KVA w/ C-25 KVA (TX IS RUSTY)
TX LOAD: 107%



PRE-ARRANGED OUTAGE NOTIFICATION REQUIRED @ TLN 2-5376-0921-0-4 1 HR DURATION

MOT 605

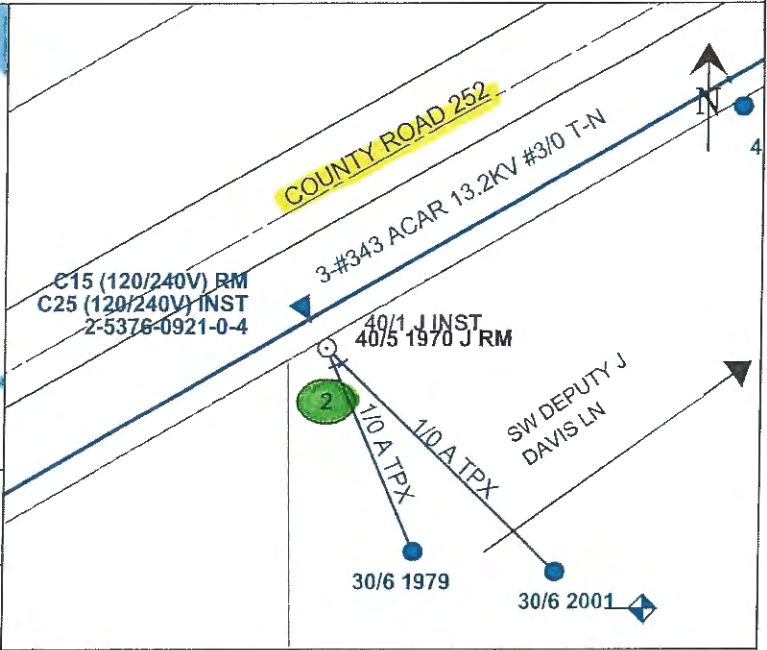
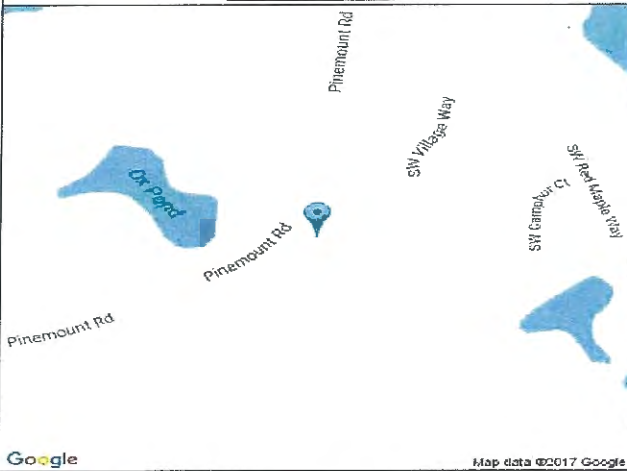

Feet of ground rod installed _____
Ground Resistance (Ohms) _____

American Disabilities Act
If pole placement location does not meet the minimum single point distance of 32" from edge of curb or back of sidewalk, contact your Production Lead, for further instructions.

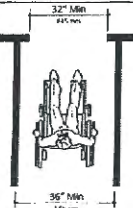

PLEASE BE ADVISED THAT RECEIPT OF THIS DRAWING AND/OR SURVEY, WHICH IS AN APPROXIMATION, DOES NOT RELIEVE YOU OF ANY STATUTORY OBLIGATIONS, INCLUDING THE PROVISIONS CONTAINED IN SECTION 556, FLORIDA STATUTES. CALL 811 (Sunshine811) PRIOR TO ANY EXCAVATION ACTIVITIES

Replace existing wood with proposed wood

AS-BUILT CREW PRINT

ALL REQUIRED GROUND RODS HAVE BEEN DRIVEN & VERIFIED TO BE WITHIN FPL STANDARDS. VALUES ARE SHOWN AT ALL LOCATIONS.

JOB CERTIFIED COMPLETED AS SHOWN ON THIS AS-BUILT PRINT. MATERIAL CHANGES SHOWN ON ROS.

AS-BUILT COPY

Foreman's Signature _____ Date _____

Foreman's Signature _____ Date _____

Supervisor's Signature _____ Date _____

Initials _____ Cert. Date _____

Easement? [] Tree Work? [] Tree Access? [] Tree Staking Req'd? []

FPL M/A: NF Township: 04 Range: 16 Section 04

Designer/Stake? [] CT/Special Mtr? [] Work with SMO? [] Survey/Stake? []

2016 PI - Pole Replacement Program

PERMIT REQ'D CITY [] COUNTY RD [X] COUNTY AIR [] STATE RD [] FAA []
WMD [] RR XING [] DR. DIST. [] TRANSM. []

F6132 11 NASH SUB., LAKE CITY, 32024

Requested Tel. Co. Set Poles? []

Tele. Attachment Per _____

Job Owner: Jeffrey Corder

Date: 07/24/2017

Requested Tel. Co. Transfer? []

Designer: Shaun Herring

Dwg No. 7723700_8x11 PIP2.xml

Request CATV Transfer? [X]

Scale: 1" = 50'

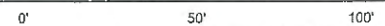

POLE LINE FT: _____

DUCT BANK FT: _____

Map No. LF1141

POLE LINE FT. ON TRANSM. POLES: _____

TRENCH FT: _____

WR: 7723700

Page 3 of 12

PRINTED BY: SXH0ZUW
Size: 8 x 11
PLOT DATE/TIME: 07/24/2017 13:21:46

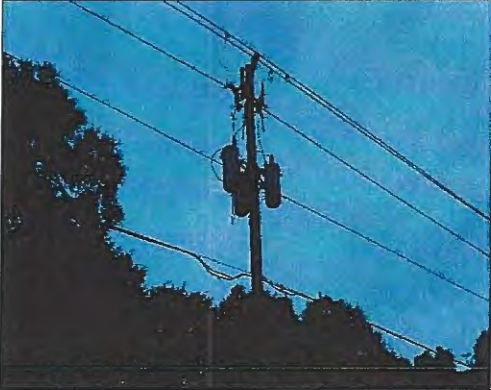
Location: A/F 113 N.W. STARLING TER.		Substation: NASH	Feeder: 06132
	Inspection Date: 04/12/2016 07:02:00	Remarks: Owner: fpl distribution. Accessibility: accessible by line truck. Previous Cycle Info: groundline treatment. Year Last Treated: 2006. Last Treated By: osmose. Other Pole Types: feeder. IWR Number: 6769334. WR Number: d00006769334. Length/Class: actual.	
	Management Area: NORTH FLORIDA		
	County: COLUMBIA		
	Franchise Name: COLUMBIA		
	BST Wire Center: LC - LAKE CITY		
	Pole ID: 1881032	FRAME PER DCS E-21.0.0 FIG 1	
	Manufacturer: KOP	REMOVE OPEN WYE BANK	
	Existing Pole Height: 40		
	Existing Pole Class: 4		
	X: -82.71699700	Y: 30.21000500	
Unique ID: 343271807			



MOT 603

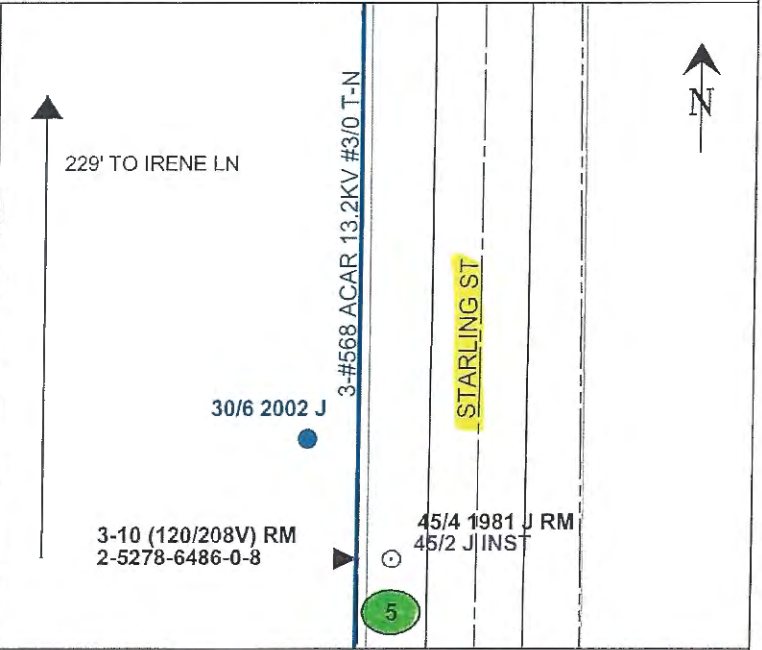
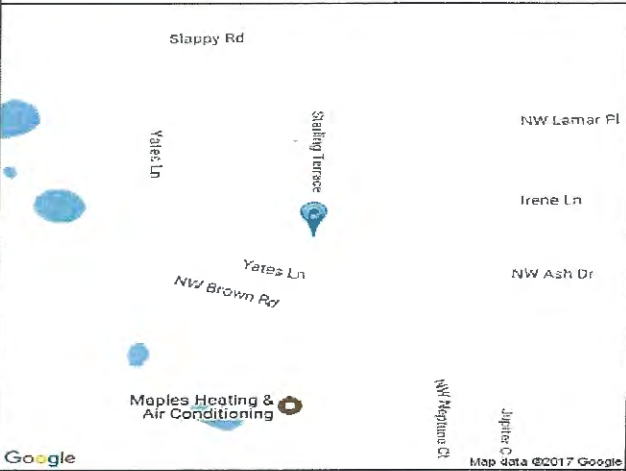

Feet of ground rod installed _____
 Ground Resistance (Ohms) _____

American Disabilities Act
 If pole placement location does not meet the minimum single point distance of 32" from edge of curb or back of sidewalk, contact your Production Lead, for further instructions.

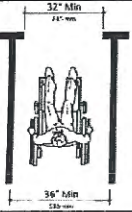

PLEASE BE ADVISED THAT RECEIPT OF THIS DRAWING AND/OR SURVEY, WHICH IS AN APPROXIMATION, DOES NOT RELIEVE YOU OF ANY STATUTORY OBLIGATIONS, INCLUDING THE PROVISIONS CONTAINED IN SECTION 556, FLORIDA STATUTES. CALL 811 (Sunshine811) PRIOR TO ANY EXCAVATION ACTIVITIES

Replace existing wood with proposed wood

AS-BUILT CREW PRINT	ALL REQUIRED GROUND RODS HAVE BEEN DRIVEN & VERIFIED TO BE WITHIN FPL STANDARDS. VALUES ARE SHOWN AT ALL LOCATIONS.	JOB CERTIFIED COMPLETED AS SHOWN ON THIS AS-BUILT PRINT. MATERIAL CHANGES SHOWN ON ROS.	AS-BUILT COPY
Foreman's Signature _____ Date _____	Foreman's Signature _____ Date _____	Supervisor's Signature _____ Date _____	Initials _____ Cert. Date _____

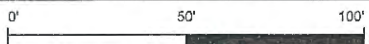
Easement? []	Tree Work? []	Tree Access? []	Tree Staking Req'd? []	FPL	M/A: NF	Township: 03 Range: 16 Section 21
Designer/Stake? []	CT/Special Mtr? []	Work with SMO? []	Survey/Stake? []	2016 PI - Pole Replacement Program		
PERMIT REC'D	CITY []	COUNTY RD [X]	COUNTY AIR []	STATE RD []	FAA []	F6132 11 NASH SUB., LAKE CITY, 32024
Requested Tel. Co. Set Poles? []	Requested Tel. Co. Transfer? []	Request CATV Transfer? [X]	Tele. Attachment Per _____	Job Owner: Jeffrey Corder	Date: 07/24/2017	
POLE LINE FT:	DUCT BANK FT:	Map No. LF1147	Scale: 1" = 50'			
POLE LINE FT. ON TRANSM. POLES:	TRENCH FT:	WR: 7723700				Page 6 of 12

PLOT DATE/TIME: 07/24/2017 13:22:53 PRINTED BY: SXHZUJW Size: 8 x 11

Location: 3RD POLE W. AND A/F 230 S.W. DEPUTY J DAVIS LN.		Substation: NASH	Feeder: 06132
	Inspection Date: 05/02/2016 08:03:00		Remarks: Can Not Treat Reason: underground cable. Owner: fpl distribution. Accessibility: accessible by line truck. Previous Cycle Info: groundline treatment. Year Last Treated: 2008. Last Treated By: osmose. Other Pole Types: feeder. IWR Number: 6769334. WR Number: d00006769334. Length/Class: actual.
	Management Area: NORTH FLORIDA		
	County: COLUMBIA		
	Franchise Name: COLUMBIA		
	BST Wire Center: LC - LAKE CITY		
	Pole ID: 218090708		
	Manufacturer: KOP		
	Existing Pole Height: 40		
	Existing Pole Class: 4		
	X: -82.70067300	Y: 30.17918500	
Unique ID: 343272565			



PRE-ARRANGED OUTAGE NOTIFICATION REQUIRED @ TLN 2-5376-7260-0-6 1 HR DURATION

MOT 605

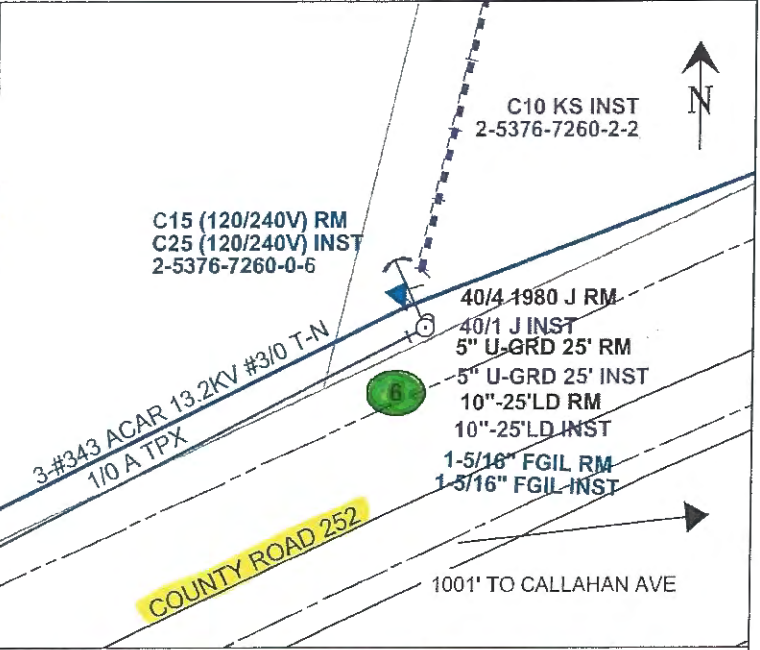

Feet of ground rod installed _____
Ground Resistance (Ohms) _____

American Disabilities Act
If pole placement location does not meet the minimum single point distance of 32" from edge of curb or back of sidewalk, contact your Production Lead, for further instructions.

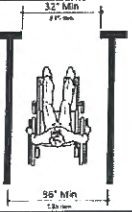

PLEASE BE ADVISED THAT RECEIPT OF THIS DRAWING AND/OR SURVEY, WHICH IS AN APPROXIMATION, DOES NOT RELIEVE YOU OF ANY STATUTORY OBLIGATIONS, INCLUDING THE PROVISIONS CONTAINED IN SECTION 556, FLORIDA STATUTES. CALL 811 (Sunshine811) PRIOR TO ANY EXCAVATION ACTIVITIES

Replace existing wood with proposed wood

AS-BUILT CREW PRINT	ALL REQUIRED GROUND RODS HAVE BEEN DRIVEN & VERIFIED TO BE WITHIN FPL STANDARDS. VALUES ARE SHOWN AT ALL LOCATIONS.	JOB CERTIFIED COMPLETED AS SHOWN ON THIS AS-BUILT PRINT. MATERIAL CHANGES SHOWN ON ROS.	AS-BUILT COPY
Foreman's Signature _____ Date _____	Foreman's Signature _____ Date _____	Supervisor's Signature _____ Date _____	Initials _____ Cert. Date _____

Easement? [] Designer/Stake? [] PERMIT REQ'D CITY [] COUNTY RD [X] COUNTY AIR [] STATE RD [] FAA [] WMD [] RR XING [] DR. DIST. [] TRANSM. []	Tree Work? [] CT/Special Mtr? [] Tree Access? [] Work with SMO? [] Tree Slaking Req'd? [] Survey/Stake? []	FPL M/A: NF Township: 03 Range: 16 Section 34 2016 PI - Pole Replacement Program F6132 11 NASH SUB., LAKE CITY, 32024
Requested Tel. Co. Set Poles? [] Requested Tel. Co. Transfer? [X] Request CATV Transfer? [X]	Tele. Attachment Per _____	Job Owner: Jeffrey Corder Date: 07/24/2017 Designer: Shaun Herring Dwg No. 7723700_8x11 PIP2.xml Scale: 1" = 50' Map No. LC1141 WR: 7723700
POLE LINE FT: _____ POLE LINE FT. ON TRANSM. POLES: _____	DUCT BANK FT: _____ TRENCH FT: _____	Page 7 of 12

Size: 8 x 11
 PRINTED BY: SXH0ZUW
 PLOT DATE/TIME: 07/24/2017 13:23:16

Location: 1 POLE W/O C/O S.W. PINEMOUNT RD. AND S.W. DEPUTY J DAVIS LN.		Substation: NASH	Feeder: 06132
	Inspection Date: 05/02/2016 10:37:00	Remarks: Owner: fpl distribution. Accessibility: accessible by line truck. Previous Cycle Info: groundline treatment. Year Last Treated: 2008. Last Treated By: osmose. Other Pole Types: feeder. IWR Number: 6769334. WR Number: d00006769334. Length/Class: estimate.	
	Management Area: NORTH FLORIDA		
	County: COLUMBIA		
	Franchise Name: COLUMBIA		
	BST Wire Center: LC - LAKE CITY	FRAME PER DCS E-25.0.0 FIG 1	
	Pole ID: 1882586	REL SPAN GUY TO NEW POLE	
	Manufacturer: UNK		
	Existing Pole Height: 40		
	Existing Pole Class: 4		
	X: -82.71135800 Y: 30.17398300		
Unique ID: 343271896			



MOT 603

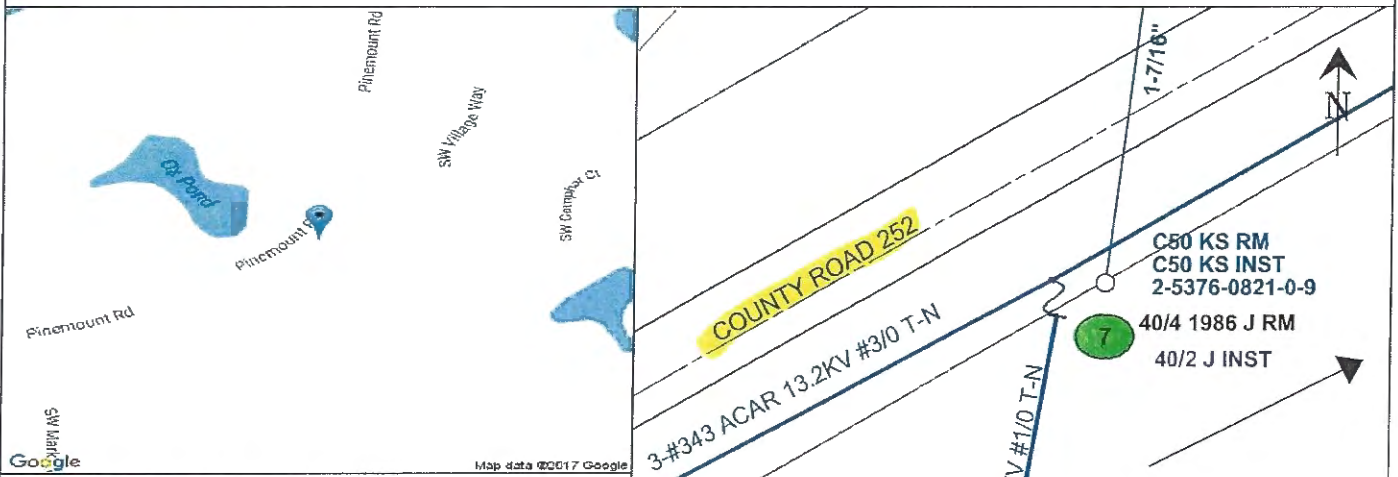

Feet of ground rod installed _____
 Ground Resistance (Ohms) _____

American Disabilities Act
 If pole placement location does not meet the minimum single point distance of 32" from edge of curb or back of sidewalk, contact your Production Lead, for further instructions.



PLEASE BE ADVISED THAT RECEIPT OF THIS DRAWING AND/OR SURVEY, WHICH IS AN APPROXIMATION, DOES NOT RELIEVE YOU OF ANY STATUTORY OBLIGATIONS, INCLUDING THE PROVISIONS CONTAINED IN SECTION 556, FLORIDA STATUTES. CALL 811 (Sunshine811) PRIOR TO ANY EXCAVATION ACTIVITIES

Replace existing wood with proposed wood

AS-BUILT CREW PRINT	ALL REQUIRED GROUND RODS HAVE BEEN DRIVEN & VERIFIED TO BE WITHIN FPL STANDARDS. VALUES ARE SHOWN AT ALL LOCATIONS.	JOB CERTIFIED COMPLETED AS SHOWN ON THIS AS-BUILT PRINT. MATERIAL CHANGES SHOWN ON ROS.	AS-BUILT COPY
Foreman's Signature _____ Date _____	Foreman's Signature _____ Date _____	Supervisor's Signature _____ Date _____	Initials _____ Cert. Date _____

Easement? []	Tree Work? []	Tree Access? []	Tree Staking Req'd? []	FPL	M/A: NF	Township: 04	Range: 16	Section 04
Designer/Stake? []	CT/Special Mtr? []	Work with SMO? []	Survey/Stake? []	2016 PJ - Pole Replacement Program				
PERMIT REQ'D	CITY []	COUNTY RD [X]	COUNTY AIR []	STATE RD []	FAA []	F6132 11 NASH SUB., LAKE CITY, 32024		
Requested Tel. Co. Set Poles? []	Requested Tel. Co. Transfer? []	Request CATV Transfer? [X]	Tele. Attachment Per _____		Job Owner: Jeffrey Corder	Date: 07/24/2017		
POLE LINE FT:	DUCT BANK FT:	TRENCH FT:	Map No. LF1138	Scale: 1" = 50'	Dwg No. 7723700_8x11 PIP2.xml			
POLE LINE FT. ON TRANSM. POLES:			WR: 7723700	0' 50' 100'		Page 8 of 12		

Size: 8 x 11
 PRINTED BY: SXH0ZUW

PLOT DATE/TIME: 07/24/2017 13:23:40

Location: 2ND POLE W/O 881 S.W. PINEMOUNT RD.		Substation: NASH	Feeder: 06132
	Inspection Date: 05/02/2016 11:16:00		Remarks: Owner: fpl distribution. Accessibility: accessible by line truck. Previous Cycle Info: groundline treatment. Year Last Treated: 2008. Last Treated By: osmose. Other Pole Types: feeder. IWR Number: 6769334. WR Number: d00006769334. Length/Class: actual.
	Management Area: NORTH FLORIDA		
	County: COLUMBIA		
	Franchise Name: COLUMBIA		
	BST Wire Center: LC - LAKE CITY		
	Pole ID: 1881974		
	Manufacturer: KOP		
	Existing Pole Height: 40		
	Existing Pole Class: 4		
	X: -82.71354300 Y: 30.17284200		
Unique ID: 343271869		FRAME PER DCS E-21.0.0 FIG 1	



MOT 603

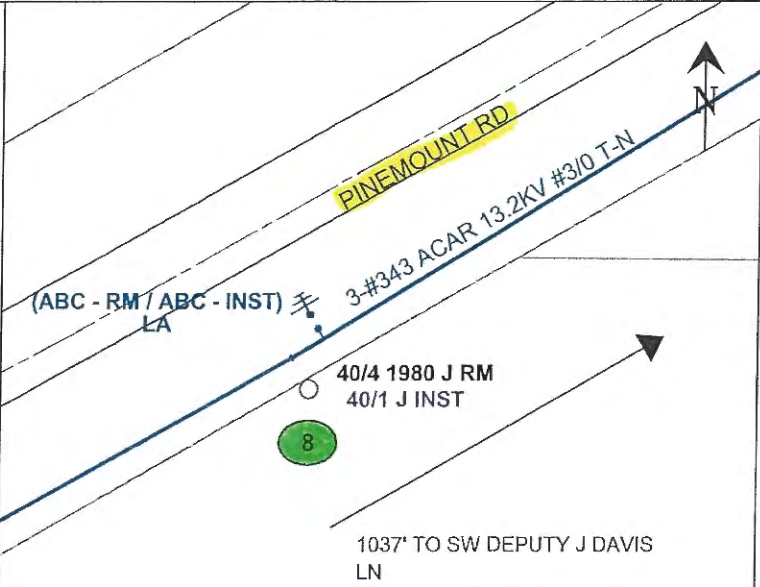

Feet of ground rod installed _____
 Ground Resistance (Ohms) _____

American Disabilities Act
 If pole placement location does not meet the minimum single point distance of 32" from edge of curb or back of sidewalk, contact your Production Lead, for further instructions.



PLEASE BE ADVISED THAT RECEIPT OF THIS DRAWING AND/OR SURVEY, WHICH IS AN APPROXIMATION, DOES NOT RELIEVE YOU OF ANY STATUTORY OBLIGATIONS, INCLUDING THE PROVISIONS CONTAINED IN SECTION 556, FLORIDA STATUTES. CALL 811 (Sunshine811) PRIOR TO ANY EXCAVATION ACTIVITIES

Replace existing wood with proposed wood

AS-BUILT CREW PRINT	ALL REQUIRED GROUND RODS HAVE BEEN DRIVEN & VERIFIED TO BE WITHIN FPL STANDARDS. VALUES ARE SHOWN AT ALL LOCATIONS.	JOB CERTIFIED COMPLETED AS SHOWN ON THIS AS-BUILT PRINT. MATERIAL CHANGES SHOWN ON ROS.	AS-BUILT COPY
Foreman's Signature _____ Date _____	Foreman's Signature _____ Date _____	Supervisor's Signature _____ Date _____	Initials _____ Cert. Date _____

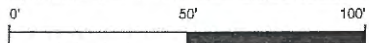
Easement? []	Tree Work? []	Tree Access? []	Tree Staking Req'd? []	FPL	M/A: NF	Township: 04 Range: 16 Section 04
Designer/Stake? []	CT/Special Mtr? []	Work with SMO? []	Survey/Stake? []	2016 PI - Pole Replacement Program		
PERMIT REQ'D	CITY []	COUNTY RD [X]	COUNTY AIR []	STATE RD []	FAA []	F6132 11 NASH SUB., LAKE CITY, 32024
Requested Tel. Co. Set Poles? []	Requested Tel. Co. Transfer? []	Request CATV Transfer? [X]	Tele. Attachment Per _____	Job Owner: Jeffrey Corder	Date: 07/24/2017	
POLE LINE FT:	DUCT BANK FT:	Map No. LF1138	Scale: 1" = 50'			
POLE LINE FT. ON TRANS. POLES:	TRENCH FT:	WR: 7723700		Page 9 of 12		

PLOT DATE/TIME: 07/24/2017 13:24:00 PRINTED BY: SX140ZUW Size: 8 x 11

[] INACCESSIBLE

[X] 13KV

[] FUTURE 23KV

[] 23KV

[] SALT SPRAY

[] ROCK

Location: 1 POLE W/O 881 S.W. PINEMOUNT RD.

Substation: NASH

Feeder: 06132

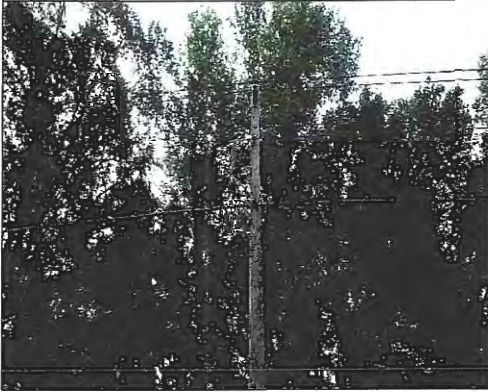

Inspection Date: 05/02/2016 11:12:00
 Management Area: NORTH FLORIDA
 County: COLUMBIA
 Franchise Name: COLUMBIA
 BST Wire Center: LC - LAKE CITY
 Pole ID: 1882172
 Manufacturer: KOP
 Existing Pole Height: 40
 Existing Pole Class: 4
 X: -82.71283800 Y: 30.17322700
 Unique ID: 343271882

Remarks: Owner: fpl distribution. Accessibility: accessible by line truck. Previous Cycle Info: groundline treatment. Year Last Treated: 2008. Last Treated By: osmose. Other Pole Types: feeder. IWR Number: 6769334. WR Number: d00006769334. Length/Class: actual.

FRAME PER DCS E-21.0.0 FIG 1



MOT 603

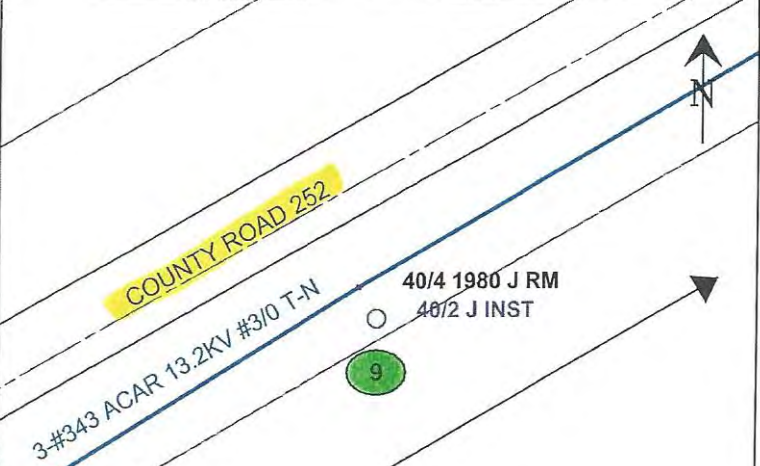

Feet of ground rod installed _____
 Ground Resistance (Ohms) _____

American Disabilities Act
 If pole placement location does not meet the minimum single point distance of 32" from edge of curb or back of sidewalk, contact your Production Lead, for further instructions.

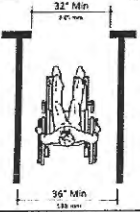

PLEASE BE ADVISED THAT RECEIPT OF THIS DRAWING AND/OR SURVEY, WHICH IS AN APPROXIMATION, DOES NOT RELIEVE YOU OF ANY STATUTORY OBLIGATIONS, INCLUDING THE PROVISIONS CONTAINED IN SECTION 556, FLORIDA STATUTES. CALL 811 (Sunshine811) PRIOR TO ANY EXCAVATION ACTIVITIES

Replace existing wood with proposed wood

797' TO SW DEPUTY J DAVIS LN

AS-BUILT CREW PRINT

ALL REQUIRED GROUND RODS HAVE BEEN DRIVEN & VERIFIED TO BE WITHIN FPL STANDARDS. VALUES ARE SHOWN AT ALL LOCATIONS.

JOB CERTIFIED COMPLETED AS SHOWN ON THIS AS-BUILT PRINT. MATERIAL CHANGES SHOWN ON ROS.

AS-BUILT COPY

Foreman's Signature _____ Date _____

Foreman's Signature _____ Date _____

Supervisor's Signature _____ Date _____

Initials _____ Cert. Date _____

Easement? [] Tree Work? [] Tree Access? [] Tree Staking Req'd? [] FPL M/A: NF Township: 04 Range: 16 Section 04

Designer/Stake? [] CT/Special Mr? [] Work with SMO? [] Survey/Stake? []

2016 PI - Pole Replacement Program

PERMIT REQD CITY [] COUNTY RD [X] COUNTY AIR [] STATE RD [] FAA []
 WMD [] RR XING [] DR. DIST. [] TRANSM. [] F6132 11 NASH SUB., LAKE CITY, 32024

Requested Tel. Co. Set Poles? [] Tele. Attachment Per Job Owner: Jeffrey Corder Date: 07/24/2017

Requested Tel. Co. Transfer? [] Designer: Shaun Herring Dwg No. 7723700_8x11 PIP2.xml

Request CATV Transfer? [X] Scale: 1" = 50' 0' 50' 100'

POLE LINE FT: DUCT BANK FT: Map No. LF1138

POLE LINE FT. ON TRANSM. POLES: TRENCH FT: WR: 7723700 Page 10 of 12

PRINTED BY: SXHOZLUW PLOT DATE/TIME: 07/24/2017 13:24:21

[] INACCESSIBLE

[X] 13KV

[] FUTURE 23KV

[] 23KV

[] SALT SPRAY

[] ROCK

Location: 281 S.W. MARKS DR.

Substation: NASH

Feeder: 06132



Inspection Date: 05/02/2016 13:44:00

Management Area: NORTH FLORIDA

County: COLUMBIA

Franchise Name: COLUMBIA

BST Wire Center: LC - LAKE CITY

Pole ID: 1881254

Manufacturer: UNK

Existing Pole Height: 40

Existing Pole Class: 5

X: -82.71562700

Y: 30.16919000

Unique ID: 343271827

Remarks: Owner: fpl distribution. Accessibility: accessible by line truck. Previous Cycle Info: groundline treatment. Year Last Treated: 2008. Last Treated By: osmose. Other Pole Types: lateral. IWR Number: 6769334. WR Number: d00006769334. Length/Class: estimate.

FRAME PER DCS I-41.0.0 AND E-5.1.0 FIG 4
REPL B-15 KVA w/ B-25 KVA (TX IS RUSTY)
TX LOAD: 120%



MOT 603

PRE-ARRANGED OUTAGE
NOTIFICATION REQUIRED
@ TLN 2-5275-8285-0-8
1 HR DURATION

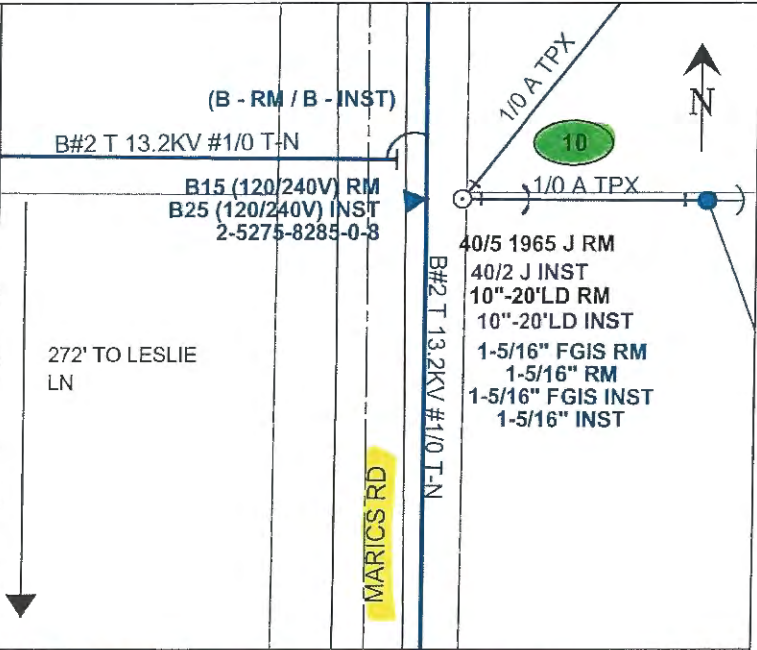

Feet of ground rod installed _____
Ground Resistance (Ohms) _____

American Disabilities Act
If pole placement location does not meet the minimum single point distance of 32" from edge of curb or back of sidewalk, contact your Production Lead, for further instructions.

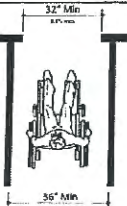

PLEASE BE ADVISED THAT RECEIPT OF THIS DRAWING AND/OR SURVEY, WHICH IS AN APPROXIMATION, DOES NOT RELIEVE YOU OF ANY STATUTORY OBLIGATIONS, INCLUDING THE PROVISIONS CONTAINED IN SECTION 556, FLORIDA STATUTES. CALL 811 (Sunshine811) PRIOR TO ANY EXCAVATION ACTIVITIES

Replace existing wood with proposed wood

AS-BUILT CREW PRINT

ALL REQUIRED GROUND RODS HAVE BEEN DRIVEN & VERIFIED TO BE WITHIN FPL STANDARDS. VALUES ARE SHOWN AT ALL LOCATIONS.

JOB CERTIFIED COMPLETED AS SHOWN ON THIS AS-BUILT PRINT. MATERIAL CHANGES SHOWN ON ROS.

AS-BUILT COPY

Foreman's Signature _____ Date _____

Foreman's Signature _____ Date _____

Supervisor's Signature _____ Date _____

Initials _____ Cert. Date _____

Easement? [] Tree Work? [] Tree Access? [] Tree Staking Req'd? []
Designer/Stake? [] CT/Special Mtr? [] Work with SMO? [] Survey/Stake? []

FPL M/A: NF Township: 04 Range: 16 Section 04
2016 PI - Pole Replacement Program

PERMIT REQ'D CITY [] COUNTY RD [X] COUNTY AIR [] STATE RD [] FAA []
WMD [] RR XING [] DR. DIST. [] TRANSM. []

F6132 11 NASH SUB., LAKE CITY, 32024

Requested Tel. Co. Set Poles? []
Requested Tel. Co. Transfer? [X]
Request CATV Transfer? [X]

Tele. Attachment Per _____
Job Owner: Jeffrey Corder Date: 07/24/2017
Designer: Shaun Herring Dwg No. 7723700_8x11 PIP2.xml

POLE LINE FT: _____ DUCT BANK FT: _____
POLE LINE FT. ON TRANSM. POLES: _____ TRENCH FT: _____

Scale: 1" = 50'
Map No. LF1138
WR: 7723700
Page 11 of 12

Size: 8 x 11
PRINTED BY: SXH0ZUW
PLOT DATE/TIME: 07/24/2017 13:24:42

Location: 2ND POLE W AND A/F 1059 PINEMOUNT RD.		Substation: NASH	Feeder: 06132
	Inspection Date: 05/03/2016 10:37:00	Remarks: Inspection Comments: ccasample. Owner: fpl distribution. Accessibility: accessible by line truck. Previous Cycle Info: groundline treatment. Year Last Treated: 2008. Last Treated By: osmose. Other Pole Types: feeder. IWR Number: 6769334. WR Number: 00006769334. Length/Class: actual.	
	Management Area: NORTH FLORIDA		
	County: COLUMBIA		
	Franchise Name: COLUMBIA		
	BST Wire Center: LC - LAKE CITY	FRAME PER DCS E-21.0.0 FIG 1	
	Pole ID: 1880990		
	Manufacturer: KOP		
	Existing Pole Height: 40		
	Existing Pole Class: 5		
	X: -82.71656700	Y: 30.17215300	
Unique ID: 343271800			



MOT 603

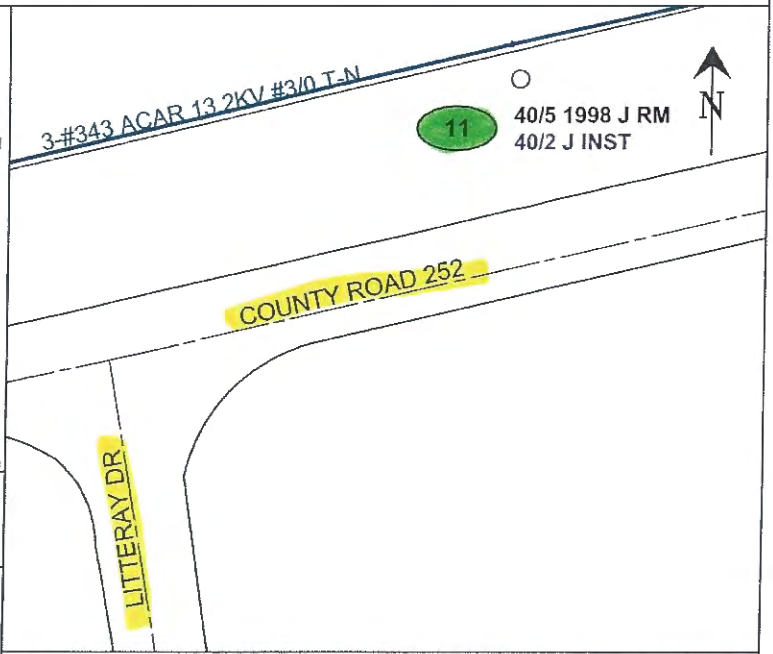

Feet of ground rod installed _____
 Ground Resistance (Ohms) _____

American Disabilities Act
 If pole placement location does not meet the minimum single point distance of 32" from edge of curb or back of sidewalk, contact your Production Lead, for further instructions.

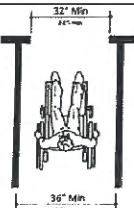

PLEASE BE ADVISED THAT RECEIPT OF THIS DRAWING AND/OR SURVEY, WHICH IS AN APPROXIMATION, DOES NOT RELIEVE YOU OF ANY STATUTORY OBLIGATIONS, INCLUDING THE PROVISIONS CONTAINED IN SECTION 556, FLORIDA STATUTES. CALL 811 (Sunshine811) PRIOR TO ANY EXCAVATION ACTIVITIES

Replace existing wood with proposed wood

AS-BUILT CREW PRINT	ALL REQUIRED GROUND RODS HAVE BEEN DRIVEN & VERIFIED TO BE WITHIN FPL STANDARDS. VALUES ARE SHOWN AT ALL LOCATIONS.	JOB CERTIFIED COMPLETED AS SHOWN ON THIS AS-BUILT PRINT. MATERIAL CHANGES SHOWN ON ROS.	AS-BUILT COPY
Foreman's Signature _____ Date _____	Foreman's Signature _____ Date _____	Supervisor's Signature _____ Date _____	Initials _____ Cert. Date _____

Easement? []	Tree Work? []	Tree Access? []	Tree Staking Req'd? []	FPL	M/A: NF	Township: 04 Range: 16 Section 04
Designer/Stake? []	CT/Special Mtr? []	Work with SMO? []	Survey/Stake? []	2016 PI - Pole Replacement Program		
PERMIT REQ'D	CITY []	COUNTY RD [X]	COUNTY AIR []	STATE RD [X]	FAA []	F6132 11 NASH SUB., LAKE CITY, 32024
Requested Tel. Co. Set Poles? []	Requested Tel. Co. Transfer? []	Request CATV Transfer? [X]	Tele. Attachment Per _____		Job Owner: Jeffrey Corder	Date: 07/24/2017
POLE LINE FT:	DUCT BANK FT:	Map No. LF1138	Scale: 1" = 50'		Dwg No. 7723700_8x11 PIP2.xml	
POLE LINE FT. ON TRANSM. POLES:	TRENCH FT:	WR: 7723700	Page 12 of 12			

Size: 8 x 11
 PRINTED BY: SXH02UW
 PLOT DATE/TIME: 07/24/2017 13:25:00

SYMBOLS:

- Work Area
- Channelizing Device (See Index No 600)
- Work Zone Sign
- Flagger
- Lane Identification + Direction of Traffic

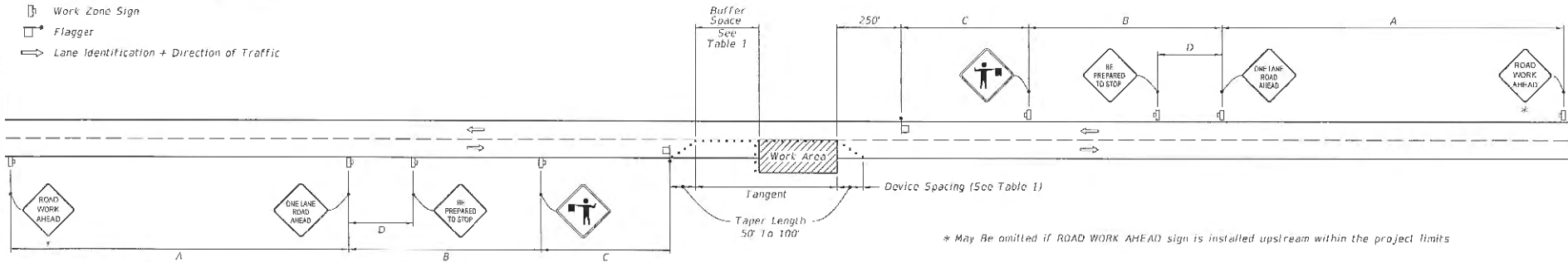

WITHOUT TEMPORARY RAISED RUMBLE STRIPS

GENERAL NOTES:

1. Special Conditions may be required in accordance with these notes and the following sheets:
 - A. Railroad Crossings:
 - a. If an active railroad crossing is located closer to the Work Area than the queue length plus 300 feet, extend the Buffer Space as shown on Sheet 3.
 - b. If the queuing of vehicles across an active railroad crossing cannot be avoided, provide a uniformed traffic control officer or flagger at the highway-rail grade crossing to prevent vehicles from stopping within the highway-rail grade crossing, even if automatic train warning devices are in place.
 - B. If the Work Area encroaches on the Centerline, use the Layout for Temporary Lane Shift to Shoulder on Sheet 3 only if the Existing Paved Shoulder width is sufficient to provide for an 11' lane between the Work Area and the Edge of Existing Paved Shoulder. Reduce the posted speed when appropriate.
2. Temporary Raised Rumble Strips:
 - A. Use when both of the following conditions are met concurrently:
 - a. Existing Posted Speed is 55 mph or greater;
 - b. Work duration is greater than 60 minutes.
 - B. Use a consistent Strip color throughout the work zone.
 - C. Place each Rumble Strip Set transversely across the lane at locations shown.
 - D. Use Option 1 or Option 2 as shown on Sheet 2. Use only one option throughout work zone.
3. Additional one-way control may be provided by the following means:
 - A. Flag-carrying vehicle;
 - B. Official vehicle;
 - C. Pilot vehicles;
 - D. Traffic signals.

When flaggers are the sole means of one-way control, the flaggers must be in sight of each other or in direct communication at all times.
4. When a side road intersects the highway within the TTC zone, place additional TTC devices in accordance with other applicable TCZ Indexes.
5. The two channelizing devices directly in front of the work area may be omitted provided vehicles in the work area have high-intensity rotating, flashing, oscillating, or strobe lights operating.
6. When Buffer Space cannot be attained due to geometric constraints, use the greatest attainable length, not less than 200 ft. for posted speeds greater than 25 mph.
7. ROAD WORK AHEAD and the BE PREPARED TO STOP signs may be omitted if all of the following conditions are met:
 - A. Work operations are 60 minutes or less.
 - B. Speed limit is 45 mph or less.
 - C. There are no sight obstructions to vehicles approaching the work area for a distance equal to the Buffer Space shown in Table 1.
 - D. Vehicles in the work area have high-intensity, rotating, flashing, oscillating, or strobe lights operating.
 - E. Volume and complexity of the roadway has been considered.
 - F. If a railroad crossing is present, vehicles will not queue across rail tracks.
 - G. AFADs are not in use.
8. See Index 600 for general TCZ requirements and additional information.
9. Automated Flagger Assistance Devices (AFADs) may be used in accordance with Specifications Section 102. 990 and the APL vendor drawings.

Posted Speed	DEVICE SPACING				Distance Between Signs				Buffer Space
	Maximum Spacing of Cones or Tubular Markers		Maximum Spacing of Type I or Type II Barricades/Panels/Drums		A	B	C	D	
	On a Taper	On a Tangent	On a Taper	On a Tangent					
25	20'	50'	20'	50'	200'	200'	200'	100'	155'
30	20'	50'	20'	50'	200'	200'	200'	100'	200'
35	20'	50'	20'	50'	200'	200'	200'	100'	250'
40	20'	50'	20'	50'	200'	200'	200'	100'	305'
45	20'	50'	20'	50'	350'	350'	350'	175'	360'
50	20'	50'	20'	100'	500'	500'	500'	250'	425'
55	20'	50'	20'	100'	2640'	1500'	1000'	500'	495'
60	20'	50'	20'	100'	2640'	1500'	1000'	500'	570'
65	20'	50'	20'	100'	2640'	1500'	1000'	500'	645'
70	20'	50'	20'	100'	2640'	1500'	1000'	500'	730'





CONDITIONS

WHERE ANY VEHICLE, EQUIPMENT, WORKERS OR THEIR ACTIVITIES ENCR OACH THE AREA BETWEEN THE CENTERLINE AND A LINE 2' OUTSIDE THE EDGE OF TRAVEL WAY.

12/27/2015 9:02:10 AM

LAST REVISION 01/01/16	DESCRIPTION:		FY 2016-17 DESIGN STANDARDS	TWO-LANE, TWO-WAY, WORK WITHIN THE TRAVEL WAY	INDEX NO. 603	SHEET NO. 1 of 3

SYMBOLS:

-  Work Area
-  Channelizing Device (See Index No. 600)
-  Work Zone Sign
-  Flagger
-  Lane Identification + Direction of Traffic

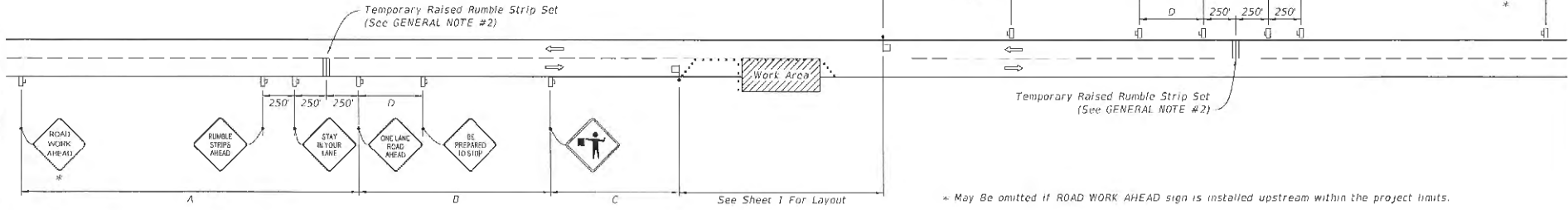

WITH TEMPORARY RAISED RUMBLE STRIPS
(When Required See GENERAL NOTE #2)

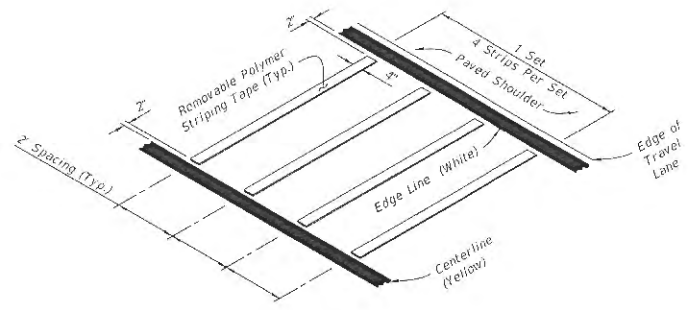

REMOVABLE POLYMER STRIPING TAPE

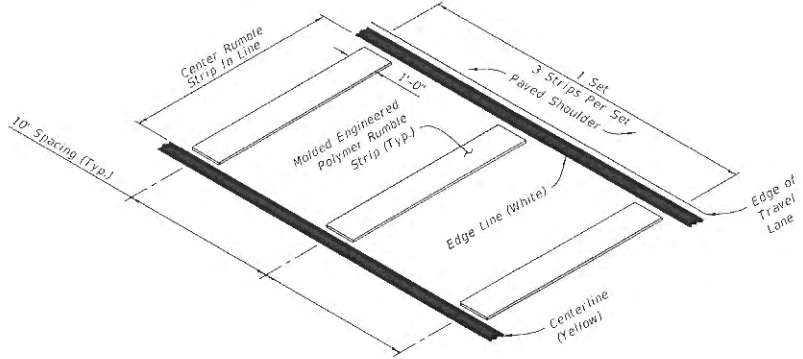

MOLDED ENGINEERED POLYMER SET

RUMBLE STRIP SET
OPTION - 1





RUMBLE STRIP SET
OPTION - 2

TEMPORARY RAISED RUMBLE STRIPS

LAST REVISION 02/04/16	DESCRIPTION:	 FY 2016-17 DESIGN STANDARDS	TWO-LANE, TWO-WAY, WORK WITHIN THE TRAVEL WAY	INDEX NO. 603	SHEET NO. 2 of 3
---------------------------	--------------	--	--	------------------	---------------------

6/6/2016 10:51:27 AM

SYMBOLS:

-  Work Area
-  Channelizing Device (See Index No. 600)
-  Work Zone Sign
-  Flagger
-  Lane Identification + Direction of Traffic

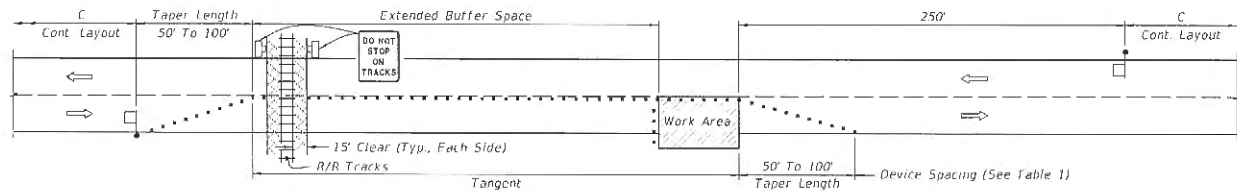

TEMPORARY RAILROAD CROSSING BUFFER SPACE EXTENSION

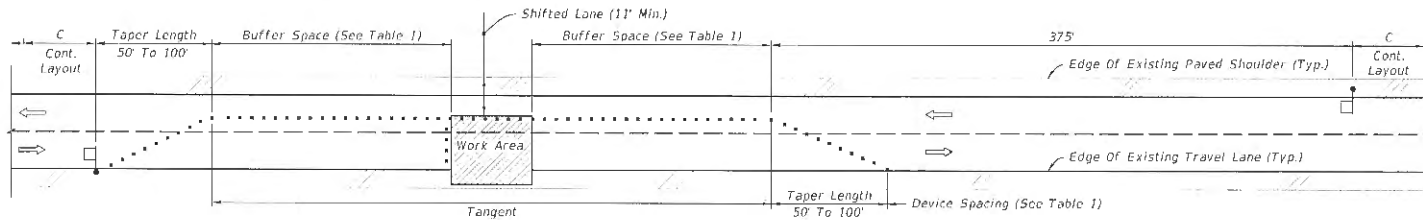

TEMPORARY LANE SHIFT TO SHOULDER WHEN WORK AREA ENCROACHES ON THE CENTERLINE

SPECIAL CONDITIONS

Cross Reference:
1. See General Note #1, Sheet 1 for more information.

SPECIAL CONDITIONS

LAST REVISION 01/01/16	DESCRIPTION:	 FY 2016-17 DESIGN STANDARDS	TWO-LANE, TWO-WAY, WORK WITHIN THE TRAVEL WAY	INDEX NO. 603	SHEET NO. 3 of 3
---------------------------	--------------	--	--	------------------	---------------------

12/31/2015 9:02:12 AM

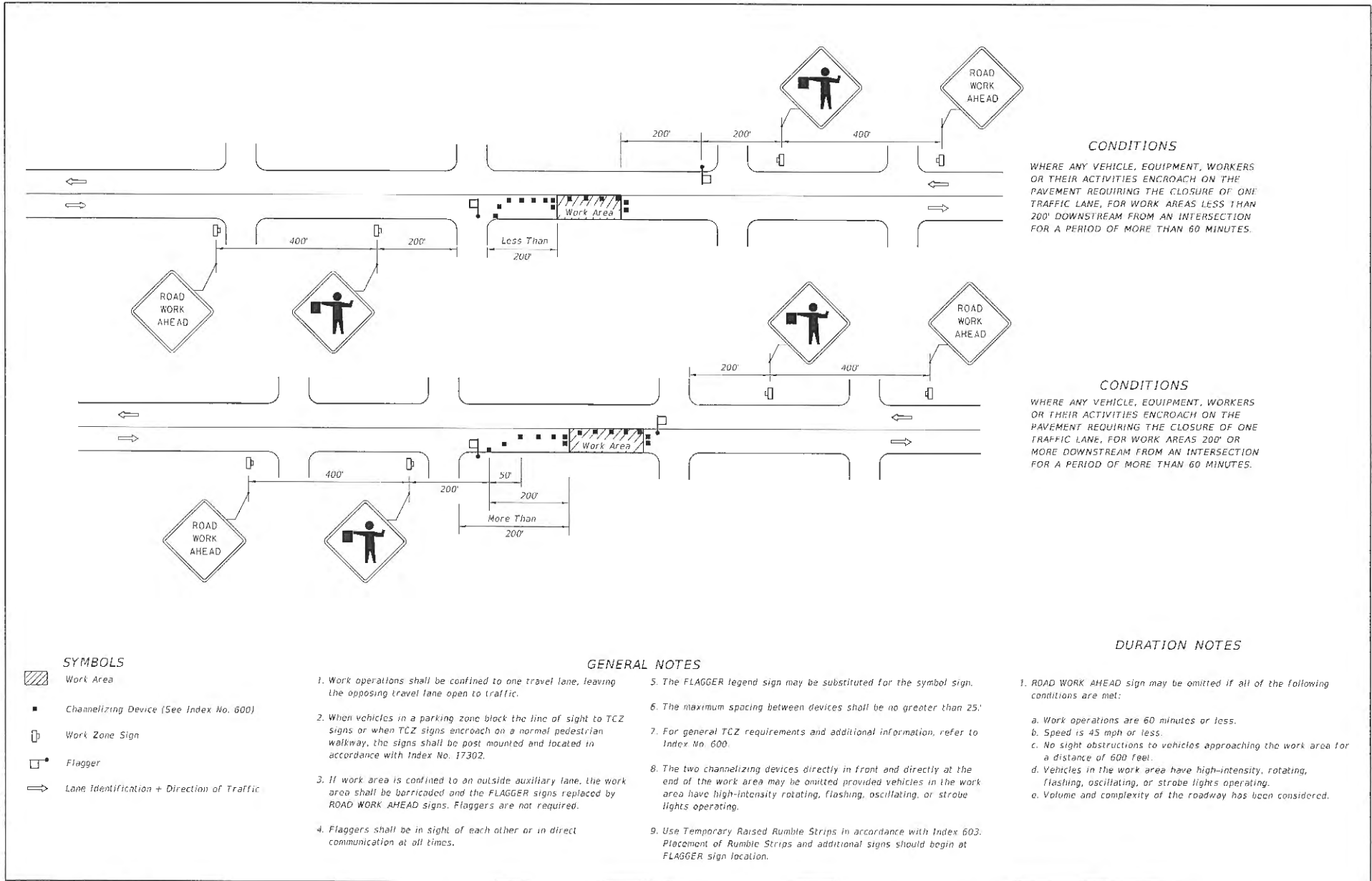

CONDITIONS

WHERE ANY VEHICLE, EQUIPMENT, WORKERS OR THEIR ACTIVITIES ENCROACH ON THE PAVEMENT REQUIRING THE CLOSURE OF ONE TRAFFIC LANE, FOR WORK AREAS LESS THAN 200' DOWNSTREAM FROM AN INTERSECTION FOR A PERIOD OF MORE THAN 60 MINUTES.

CONDITIONS

WHERE ANY VEHICLE, EQUIPMENT, WORKERS OR THEIR ACTIVITIES ENCROACH ON THE PAVEMENT REQUIRING THE CLOSURE OF ONE TRAFFIC LANE, FOR WORK AREAS 200' OR MORE DOWNSTREAM FROM AN INTERSECTION FOR A PERIOD OF MORE THAN 60 MINUTES.

DURATION NOTES

1. ROAD WORK AHEAD sign may be omitted if all of the following conditions are met:
 - a. Work operations are 60 minutes or less.
 - b. Speed is 45 mph or less.
 - c. No sight obstructions to vehicles approaching the work area for a distance of 600 feet.
 - d. Vehicles in the work area have high-intensity, rotating, flashing, oscillating, or strobe lights operating.
 - e. Volume and complexity of the roadway has been considered.

- SYMBOLS**
- Work Area
 - Channelizing Device (See Index No. 600)
 - Work Zone Sign
 - Flagger
 - Lane Identification + Direction of Traffic

GENERAL NOTES

1. Work operations shall be confined to one travel lane, leaving the opposing travel lane open to traffic.
2. When vehicles in a parking zone block the line of sight to TCZ signs or when TCZ signs encroach on a normal pedestrian walkway, the signs shall be post mounted and located in accordance with Index No. 17302.
3. If work area is confined to an outside auxiliary lane, the work area shall be barricaded and the FLAGGER signs replaced by ROAD WORK AHEAD signs. Flaggers are not required.
4. Flaggers shall be in sight of each other or in direct communication at all times.
5. The FLAGGER legend sign may be substituted for the symbol sign.
6. The maximum spacing between devices shall be no greater than 25'.
7. For general TCZ requirements and additional information, refer to Index No. 600.
8. The two channelizing devices directly in front and directly at the end of the work area may be omitted provided vehicles in the work area have high-intensity rotating, flashing, oscillating, or strobe lights operating.
9. Use Temporary Raised Rumble Strips in accordance with Index 603. Placement of Rumble Strips and additional signs should begin at FLAGGER sign location.

LAST REVISION 07/01/15	REVISION	DESCRIPTION:	 FY 2016-17 DESIGN STANDARDS	TWO-LANE, TWO-WAY, WORK NEAR INTERSECTION	INDEX NO. 605	SHEET NO. 1 of 1
---------------------------	----------	--------------	------------------------------------	---	------------------	---------------------

5/16/2015 5:04:27Z
 07 08 2016



COLUMBIA COUNTY BOARD OF COUNTY COMMISSIONERS
AGENDA ITEM REQUEST FORM

The Board of County Commissioners meets the 1st and 3rd Thursday of each month at 5:30 p.m. in the Columbia County School Board Administrative Complex Auditorium, 372 West Duval Street, Lake City, Florida 32055. All agenda items are due in the Board's office one week prior to the meeting date.

Today's Date: July 21, 2017 Meeting Date: August 3, 2017

Name: Kevin Kirby Department: Public Works

Division Manager's Signature: [Handwritten Signature]

1. Nature and purpose of agenda item:

Right-of-Way Easement from Clay Electric at the Ellisville Fire Station

Attach any correspondence information, documents and forms for action i.e., contract agreements, quotes, memorandums, etc.

2. Fiscal impact on current budget.

Is this a budgeted item? [X] N/A [] Yes Account No. [] No Please list the proposed budget amendment to fund this request

Budget Amendment Number: Fund:

FROM: TO: AMOUNT:

For Use of County Manger Only:

[X] Consent Item [] Discussion Item

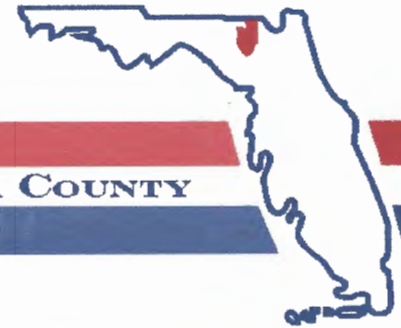

BOARD OF COUNTY COMMISSIONERS • COLUMBIA COUNTY

Memo

Date: July 20, 2017
To: Ben Scott, County Manager
From: Kevin Kirby, Assistant County Manager 
RE: Right-of-Way Easement

Attached you will find a Right-of-Way Easement from Clay Electric along with Exhibit "A" County Parcel No. 275S-17-09416-003 also known as the Ellisville Fire Department.

This easement will provide Clay Electric access to install an overhead electrical line for property located to the east for a new residential home construction project.

I recommend that we approve the easement.

If you should need any additional information, please contact me.

Prepared by: Craig Wacha/Lori Harkey

Return to:
Clay Electric Cooperative, Inc.
Real Estate Division
Post Office Box 308
Keystone Heights, FL 32656

Clay Electric Property No:8777533

Tax Parcel No.:27-5S-17-09416-003

RIGHT-OF-WAY EASEMENT

Clay Electric Cooperative, Inc.

GRANTORS, (whether singular or plural)

COUNTY of COLUMBIA,

A political subdivision of the State of Florida

SPACE ABOVE THIS LINE FOR RECORDING

Whose mailing address is: PO BOX 1529

City LAKE CITY State FLORIDA Zip 32056

In consideration of one dollar and other good and valuable considerations, the receipt of which is hereby acknowledged, do(es) hereby grant, bargain, sell And convey to Clay Electric Cooperative, Inc., a Florida Corporation, of P. O. Box 308, Keystone Heights, Florida, 32656, hereinafter called the "Cooperative", its successors and assigns, a perpetual easement TWENTY (20) feet in width over, under, upon and across the Lands and real property situate, lying and being in the County of COLUMBIA, State of Florida, more particularly described as follows:

A Non-exclusive easement twenty (20) feet in width being ten (10) feet on each side of the centerline of an overhead electrical distribution system and associated facilities over, under, upon and across parcel of land lying in Section 27, Township 5 South, Range 17 East, Columbia County, Florida.

Said parcel being more particularly described in ORB 738 Page 207 of the public records of Columbia County, Florida and on the attached Exhibit "A".

together with a perpetual easement over, under, upon and across all streets, roads, alleys, easements and rights-of-way in any plat or subdivision of which the above described property is a part, to the extent of Grantor's interest therein. The right to construct, rebuild, operate, and maintain electric lines and systems on or under the above described lands; the right to inspect, repair, change, alter, improve, remove, and add to such facilities and systems as the Cooperative deems advisable, including, by way of example, and not by way of limitation, the right to alter, modify, increase or decrease the number and size of conduits, wires, voltage, poles, cables, down guys, transformers, transformer enclosures, regulators, and all necessarily related equipment; the right to cut, trim, remove, and control the growth of trees, shrubberies, and other plants in the easement area by all means available, and not prohibited by law, that may, in the judgement of the Cooperative, interfere with, threaten or endanger the operation and maintenance of the Cooperative's facilities and systems; the right to keep the easement clear of all buildings, structures or other obstructions except citrus trees and low-growing shrubbery that do not otherwise in the judgement of the Cooperative interfere with Cooperative's use of the easement and right-of-way; the right to license, permit, or otherwise agree to the joint use or occupancy of the easement, facilities or system whether over land or under ground by other utilities, persons, associations, or corporations, and the right to enter upon, cross, and use other lands of the Grantors to provide reasonable access to the easement granted herein. Grantor agrees that all equipment, poles, wire, facilities, and other tangible personal property, together with any other improvements to the easement and right-of-way installed by or on behalf of the Cooperative, shall remain the sole and exclusive property of the Cooperative, and shall not be subject to any interest or claim of Grantor. Grantor covenants with Grantee that he is lawfully seized of the land in fee simple, that he has good, right and lawful authority to grant, bargain, sell, and convey the land and the interest herein conveyed. Grantor reserves the right to use the underlying fee for farming, citrus grove, or pasture purposes, provided that such use shall not include the construction, placement or location of any structures in the easement area, nor any use that would, in the judgement of the Cooperative, interfere with the Cooperative's use and enjoyment of the easement. Grantor agrees that this right-of-way easement is perpetual and shall run with the land, and that any abandonment or interruption of the use of the easement and right-of-way shall not terminate or impair the interests hereby conveyed to the Cooperative.

IN WITNESS WHEREOF, the Grantors have hereunto affixed their hands and seals this _____ day of _____, 20 17 .

SIGNED, SEALED AND DELIVERED IN THE PRESENCE OF:

First,
Witness Signature: X

By: X (seal)

Also,
Type/Print Name: _____

Type/Print Name: **RONALD WILLIAMS,
Chairman of the Board of Columbia County Commissioners**

Second,
Witness Signature: X

By: _____ (seal)

Also,
Type/Print Name: _____

Type/Print Name: _____

STATE OF FLORIDA

COUNTY OF COLUMBIA

The foregoing instrument was acknowledged before me this _____ day of _____, 20 17

by RONALD WILLIAMS, personally known to me or who
(Name of grantor whether one or more)

has (have) produced _____ as identification .
(Type of identification)

(Signature: X) _____ Notary Public

Also,
Type/Print Name: _____

Commission Expires: _____ Commission No. _____

(Notary Seal)

EXHIBIT A:

Commence at the point of intersection of the South line of Section 27, Township 5 South, Range 17 East, Columbia County, Florida and the Easterly Right-of-Way line of U.S. Highway No. 441 and run N 01°33'31" W along said Easterly Right-of-Way line 62.23 feet to the POINT OF BEGINNING; thence continue N 01°33'31" W still along said Easterly Right-of-Way line 208.71 feet to its intersection with the centerline of a 100 foot powerline easement; thence N 87°48'04" E along said centerline and its projection thereof 208.71 feet; thence S 01°33'31" E parallel to the Easterly Right-of-Way line of U.S. Highway No. 441 a distance of 208.71 feet; thence S 87°48'04" W 208.71 feet to the POINT OF BEGINNING. Containing 1.00 acres, more or less.



COLUMBIA COUNTY BOARD OF COUNTY COMMISSIONERS
AGENDA ITEM REQUEST FORM

The Board of County Commissioners meets the 1st and 3rd Thursday of each month at 5:30 p.m. in the Columbia County School Board Administrative Complex Auditorium, 372 West Duval Street, Lake City, Florida 32055. All agenda items are due in the Board's office one week prior to the meeting date.

Today's Date: July 18, 2017 Meeting Date: August 3, 2017

Name: Ray Hill Department: Purchasing

Division Manager's Signature: [Handwritten Signature]

1. Nature and purpose of agenda item:

Award Bid No. 2017-Q to Low Bidder Sun Professional Supply in the amount of \$46,980.

Attach any correspondence information, documents and forms for action i.e., contract agreements, quotes, memorandums, etc.

2. Fiscal impact on current budget.

Is this a budgeted item? [] N/A [X] Yes Account No. 10142705416064 [] No Please list the proposed budget amendment to fund this request

Budget Amendment Number: Fund:

FROM: TO: AMOUNT:

For Use of County Manger Only:

[X] Consent Item [] Discussion Item

District No. 1 - Ronald Williams
District No. 2 - Rusty DePratter
District No. 3 - Bucky Nash
District No. 4 - Everett Phillips
District No. 5 - Tim Murphy

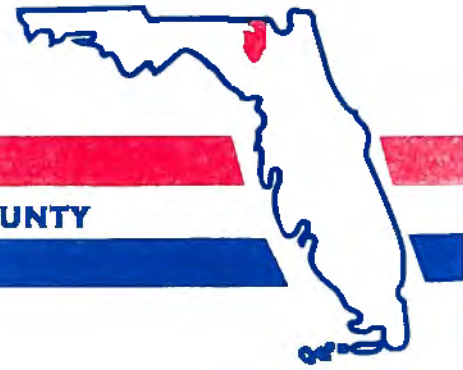

BOARD OF COUNTY COMMISSIONERS • COLUMBIA COUNTY

Memo

Date: July 18, 2017
To: Board of Commissioners
From: Ray Hill, Purchasing Director
RE: Final Ranking Bid No. 2017-Q

I have reviewed the bid response for Bid No. 2017-Q with Kevin Kirby and the public works department. It is our recommendation we accept the bid provided by Sun Professional Supply, LLC. They were the only bidder and there bid was within our estimated cost and met all the specifications of the bid.

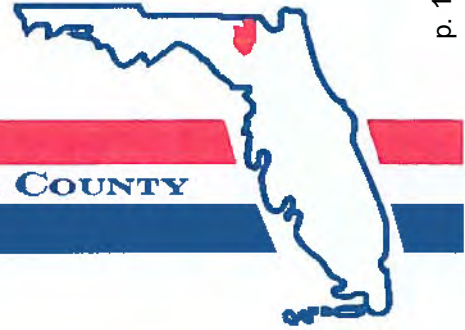

BOARD OF COUNTY COMMISSIONERS • COLUMBIA COUNTY

Memo

Date: July 14, 2017
To: Ray Hill, Purchasing Director
From: Kevin Kirby, Assistant County Manager
RE: Pipe Washer/Motor Grader Purchases

A handwritten signature in blue ink, appearing to be 'K Kirby', is written over the 'From:' line of the memo header.

I am in receipt of a copy of the bids for the above two (2) referenced items.

Pipe Washer low bid was Sun Professional Supply, LLC at \$46,980. Low bidder for the (3) motor graders was Beard Equipment/John Deere at \$317,118.

Please proceed with having the bids approved and executed from the lowest bidder as soon as possible.

Thank you.

**BID FORM
2017-Q
Pipe Washer
COLUMBIA COUNTY BOARD OF COUNTY COMMISSIONERS**

Bids must be received in the Office of the Board of County Commissioners, Columbia County, 135 NE Hernando Avenue, Room 203, Lake City, FL, 32055 no later than 11:00 A.M., on July 11, 2017. Columbia County reserves the right to reject any and/or all bids and to accept the bid in the county's best interest, bid F.O.B., Columbia County, Florida.

Lump Sum \$ 46,980.00

I certify that this bid meets or exceeds the County specifications and that the undersigned bidder declares that I have carefully examined the specifications, term and conditions of this bid and I am thoroughly familiar with its provisions. The undersigned bidder further declares that he/she has not divulged, discussed or compared his bid with any other bidders and has not colluded with any other bidders or parties to a bid whatsoever for any fraudulent purpose.

COMPANY: Sun Professional Supply, LLC DATE: 19 June 17

ADDRESS: 5466 W. Beaver St. Jacksonville, FL 32254

PHONE NO: (904) 693-2155

EMAIL: jseibel@sunprosupply.com

SIGNATURE:  _____

PRINT NAME/TITLE: John Seibel - Managing Partner



COLUMBIA COUNTY BOARD OF COUNTY COMMISSIONERS
AGENDA ITEM REQUEST FORM

The Board of County Commissioners meets the 1st and 3rd Thursday of each month at 5:30 p.m. in the Columbia County School Board Administrative Complex Auditorium, 372 West Duval Street, Lake City, Florida 32055. All agenda items are due in the Board's office one week prior to the meeting date.

Today's Date: July 18, 2017 Meeting Date: August 3, 2017

Name: Mario Coppock Department: Recreation

Division Manager's Signature: Ben Scott

1. Nature and purpose of agenda item:

Budget amendment for a new network switch and surveillance camera. BA 17-63; total amendment \$2,620.

Attach any correspondence information, documents and forms for action i.e., contract agreements, quotes, memorandums, etc.

2. Fiscal impact on current budget.

Is this a budgeted item? [] N/A [] Yes Account No. [X] No Please list the proposed budget amendment to fund this request

Budget Amendment Number: BA 17-63 Fund: 001-GENERAL FUND

Table with 3 columns: FROM, TO, AMOUNT. FROM: 001-8400-584.90-99 RESERVES / CONTINGENCY/RESERVE TO: 001-7200-572.30-64 OPERATING EXPENDITURES / NON-CAPITAL EQUIPMENT AMOUNT: \$2,620.00

For Use of County Manger Only:

[X] Consent Item [] Discussion Item



Columbia County Recreation Department

Post Office Box 1529 • 255 NE Coach Anders Lane

Lake City, FL 32056

Telephone: 386-754-7095 • Fax 386-754-7097 • Email: mario_coppock@columbiacountyfla.com

Mario A. Coppock, CPRP, CPM

Director

MEMORANDUM

DATE: July 18, 2017

TO: Ben Scott, County Manger

FR: Mario Coppock, Recreation Director

RE: Budget Amendment for Surveillance System Repairs

I am requesting a budget amendment to purchase a new network switch to operate the camera surveillance system. During a recent update by the camera system company, the switch began to malfunction and would not provide access from the office computers. After inspection, IT Director Todd Manning suggested replacing the switch to remedy the access issues. An additional camera also needs to be purchased to replace one of the cameras that is no longer functioning properly.

Quotes were provided from the IT department to replace both the switch and the camera. The total request for the budget amendment is \$2,619.95. Quotes are attached.

Mario A. Coppock

The Mission of the Columbia County Recreation Department is to meet the community's need for diverse, affordable, professionally managed recreation programs for children and adults, while maintaining a clean and safe environment.



Strictly Technology
 5381 NW 33rd Avenue
 Suite 101
 Fort Lauderdale, Florida 33309
 United States
 (P) (954) 606-5440
 (F) (954) 606-5441

Quotation (Open)

Date
 Jun 27, 2017 11:14 AM
 EDT

Modified Date
 Jun 27, 2017 11:16 AM
 EDT

Doc #
 28834 - rev 1 of 1

Description
 Cisco Catalyst 2960X-48LPS-L Switch

SalesRep
 McLeod, Ethan
 (P) 9546065440
 (F) 9546065441

Customer Contact
 Todd, Manning
 (P) 386-719-7442
 (F) 386-758-2182
 Todd_manning@columbiacountyfla.com

Customer

Columbia County FL (13-695)
 Todd, Manning
 P.O. Box 1529
 Lake City, FL 32056-1529
 United States
 (P) 386-758-1005
 (F) 386-758-2182

Bill To

Columbia County FL
 Todd , Manning
 P.O. Box 1529
 Lake City, FL 32056-1529
 United States
 (P) 386-758-1005
 (F) 386-758-2182

Ship To

Columbia County Board of
 Commissioners
 Todd , Manning
 135 NE Hernando Ave.
 Suite 203
 Lake City, FL 32055
 United States
 (P) 386-758-1005
 (F) 386-758-2182

Customer PO:

Terms:
 Undefined

Ship Via:
 FedEx Ground

Special Instructions:

Carrier Account #:

#	Image	Description	Part #	Tax	Qty	Unit Price	Total
1		Cisco Catalyst 2960X-48LPS-L Switch - managed - 48 x 10/100/1000 (PoE+) + 4 x Gigabit SFP - desktop, rack-mountable - PoE+ (370 W)	WS-C2960X- 48LPS-L	Yes	1	\$2,499.00	\$2,499.00

Quoted price may reflect manufacture incentives, special discounts, rebates and quantities. Changes to this quote may affect pricing. Contact your sales representative for more information.

Prices exclude applicable taxes, insurance, shipping and special handling charges unless stated. All prices are subject to change without notice. Supply subject to availability.

Subtotal: \$2,499.00
 Tax (0.000%): \$0.00
 Shipping: \$0.00
Total: \$2,499.00



QUOTE CONFIRMATION

DEAR DAVID MOORE,

Thank you for considering CDW•G for your computing needs. The details of your quote are below. [Click here](#) to convert your quote to an order.

QUOTE #	QUOTE DATE	QUOTE REFERENCE	CUSTOMER #	GRAND TOTAL
1BRM73W	7/7/2017	RICHARDSON	5709152	\$120.95

IMPORTANT - PLEASE READ

Special Instructions: Beginning of customer text:
Ferguson building bathrooms
End of customer text.

QUOTE DETAILS

ITEM	QTY	CDW#	UNIT PRICE	EXT. PRICE
TRENDnet TV IP310PI Outdoor 3 MP PoE Day/Night Network Camera - network sur	1	3341287	\$120.95	\$120.95
Mfg. Part#: TV-IP310PI UNSPSC: 46171610 Contract: NJPA 100614#CDW Technology Catalog (100614#CDW)				

PURCHASER BILLING INFO	SUBTOTAL	\$120.95
Billing Address: COLUMBIA COUNTY ACCTS PAYABLE PO BOX 1529 LAKE CITY, FL 32056-1529 Phone: (386) 719-2028 Payment Terms:	SHIPPING	\$0.00
	GRAND TOTAL	\$120.95
DELIVER TO	Please remit payments to:	
Shipping Address: ATTN: TODD MANNING ATTN:DAVID MOORE 135 NE HERNANDO AVE. RM 203 LAKE CITY, FL 32056 Phone: (386) 719-2028 Shipping Method: UPS Ground	CDW Government 75 Remittance Drive Suite 1515 Chicago, IL 60675-1515	

Need Assistance? CDW•G SALES CONTACT INFORMATION



Mike Buckley

(866) 668-9496

mikbuck@cdwg.com

This quote is subject to CDW's Terms and Conditions of Sales and Service Projects at <http://www.cdw.com/content/terms-conditions/product-sales.aspx>
For more information, contact a CDW account manager

© 2017 CDW•G LLC, 200 N. Milwaukee Avenue, Vernon Hills, IL 60061 | 800.808.4239