

**COLUMBIA COUNTY BOARD OF COUNTY COMMISSIONERS**

**POST OFFICE BOX 1529  
LAKE CITY, FLORIDA 32056-1529**

**CONSENT AGENDA**

**March 2, 2017**

**5:30 P.M.**

- 
- (1) BCC Administration - Approval of Friday, December 22, 2017 - Alternate Day to Observed Christmas Eve Holiday (Pg. 1)**
  - (2) Building & Zoning - Special Family Lot Permit (SFLP 17 30) - Gary W. Laxton, Jr. (Pg. 3)**
  - (3) Emergency Communications Center - Request to Apply Spring 2017 E-911 Board Rural Grant - 911 Support & Maintenance - \$67,210 (Pg. 14)**
  - (4) Emergency Management - Approve Lease Agreement - Marcotek - Upgrade Xerox Copy Machine - \$190 Monthly (Pg. 76)**
  - (5) Human Resources - Worxtime Amendment - Service Agreement - Estimated Cost \$1,000 (Pg. 81)**
  - (6) Operations Department - Utility Permit - AT&T - SW Tustenuggee Ave and SW Bedenbaugh Ln - Placement of Buried Fiber Cable (Pg. 84)**
  - (7) Operations Department - Utility Permit - Florida Power and Light - NW Moore Farm Rd - Installing Directional Bore (Pg. 98)**
  - (8) Operations Department - Permission to Enter Private Property - SW Bunn Drive - Tree Removal (Pg. 110)**
  - (9) Operations Department - Permission to Enter Private Property - Parcel #09068-000 - Tree Removal (Pg. 114)**
  - (10) Operations Department - Permission to Enter Private Property - 1152 SW Little Road - Tree Removal (Pg. 119)**





# 1

COLUMBIA COUNTY BOARD OF COUNTY COMMISSIONERS
AGENDA ITEM REQUEST FORM

The Board of County Commissioners meets the 1st and 3rd Thursday of each month at 5:30 p.m. in the Columbia County School Board Administrative Complex Auditorium, 372 West Duval Street, Lake City, Florida 32055. All agenda items are due in the Board's office one week prior to the meeting date.

Today's Date: February 16, 2017 Meeting Date: March 2, 2017

Name: Penny Stanley Department: BCC Administration

Division Manager's Signature: [Handwritten Signature]

1. Nature and purpose of agenda item:

BCC Administration - Requesting Approval of Friday, December 22, 2017 as Alternate Day to Observed Christmas Eve Holiday

Attach any correspondence information, documents and forms for action i.e., contract agreements, quotes, memorandums, etc.

2. Fiscal impact on current budget.

Is this a budgeted item? [X] N/A [ ] Yes Account No. [ ] No Please list the proposed budget amendment to fund this request

Budget Amendment Number: Fund:

FROM: TO: AMOUNT:

For Use of County Manger Only:

[X] Consent Item [ ] Discussion Item

District No. 1 - Ronald Williams  
District No. 2 - Rusty DePratter  
District No. 3 - Bucky Nash  
District No. 4 - Everett Phillips  
District No. 5 - Tim Murphy



**BOARD OF COUNTY COMMISSIONERS • COLUMBIA COUNTY**

**MEMORANDUM**

**TO:** Board of County Commissioners  
**FROM:** Lisa K.B. Roberts  Human Resources Director  
**DATE:** February 16, 2017  
**SUBJECT:** Christmas Holiday Designation

In accordance with Columbia County Board of County Commissioners Personnel Policies and Procedures Manual, Chapter 18-Holidays, Christmas Eve, December 24<sup>th</sup> is observed on the last work day before Christmas (December 25<sup>th</sup>). County policy allows the Board of County Commission to approve an alternate day to observe Christmas Eve, depending on the day Christmas Eve falls.

This year Christmas Day falls on Monday, December 25, 2017 which is a regular Observed Holiday in accordance with County Policy and the County facilities will be closed. Christmas Eve falls on Sunday, December 24, 2017. Since Sunday is not a regular scheduled work day, it is requested the Board approve Friday, December 22, 2017 as the alternate day to observe Christmas Eve. Therefore County offices would be closed for Christmas Holiday observance on the following days:

Friday, December 22, 2017 – Alternate Day to Observed Christmas Eve Holiday  
Monday, December 25, 2017 – County Observed Christmas Holiday

Thank you for your consideration of the above stated request. If you have any questions regarding the same, please contact me at (386) 758-1006.

XC: Ben Scott, County Manager

BOARD MEETS FIRST THURSDAY AT 5:30 P.M.  
AND THIRD THURSDAY AT 5:30 P.M.





# 2

COLUMBIA COUNTY BOARD OF COUNTY COMMISSIONERS
AGENDA ITEM REQUEST FORM

The Board of County Commissioners meets the 1st and 3rd Thursday of each month at 5:30 p.m. in the Columbia County School Board Administrative Complex Auditorium, 372 West Duval Street, Lake City, Florida 32055. All agenda items are due in the Board's office one week prior to the meeting date.

Today's Date: February 13, 2017 Meeting Date: March 2, 2017

Name: Brandon M. Stubbs Department: Building And Zoning

Division Manager's Signature: [Handwritten Signature]

1. Nature and purpose of agenda item:

Special Family Lot Permit (SFLP 17 30) for Gary W. Laxton, Jr. (Son of Gary Laxton).

Attach any correspondence information, documents and forms for action i.e., contract agreements, quotes, memorandums, etc.

2. Fiscal impact on current budget.

Is this a budgeted item? [X] N/A [ ] Yes Account No. [ ] No Please list the proposed budget amendment to fund this request

Budget Amendment Number: Fund:

FROM: TO: AMOUNT:

For Use of County Manger Only:

[X] Consent Item [ ] Discussion Item



## NOTICE TO APPLICANT

A special family lot permit may be issued by the Board of County Commissioners on land zoned Agricultural or Environmentally Sensitive Area within these Land Development Regulations, for the purpose of conveying a lot or parcel to an immediate family member who is the parent, grandparent, adopted parent, stepparent, sibling, child, or adopted child, stepchild or grandchild of the person who conveyed the parcel to said individual, **not to exceed one (1) dwelling unit per one (1) acre** and the lot complies with all other conditions from permitting development as set forth in these Land Development Regulations. This provision is intended to promote the perpetuation of the family homestead in rural areas by making it possible for immediate family members to reside on lots as their primary residence which exceed maximum density for such areas, provided that the lot complies with the conditions for permitting established in Section 14.9 of the Land Development Regulations.

If approved by the Board of County Commissioner, the division of lots shall be recorded by separate deed, comply with all other applicable regulations of the Land Development Regulations, and comply with all other conditions for permitting and development as set forth in the Land Development Regulations. A completed building permit application shall be submitted within one (1) year of receiving approval by the Board of County Commissioners. One (1) extension can be requested in writing and approved by the Land Development Regulations Administrator not to exceed nine (9) months. If a special family lot permit expires, it shall have to go through the process again for approval as required by this section. A building permit for a special family lot shall be issued only to the immediate family member or their authorized representative (i.e. licensed building contractor or mobile home installer) after a recorded copy of the family relationship residence agreement affidavit and deed to the special family lot has been submitted to the Land Development Regulation Administrator as part of the building permit application process.

Special family lots which have not met the requirements for homestead exemption shall not be transferable except, as follows:

1. The deeding of the parcel back to the original owner of the parent tract as indicated in Section 14.9 of the Land Development Regulations;
2. To another individual meeting the definition of immediate family member;
3. To an individual not meeting the definition of immediate family member due to circumstances beyond the reasonable control of the family member to whom the original special family lot permit was granted such as divorce, death or job change resulting in unreasonable commuting distances, the immediate family member is no longer able to retain ownership of the special family lot, subject to approval by the original reviewing body that approved the special family lot permit; and
4. Upon approval of the transfer of the special family lot, the County will issue a Certificate of Transfer and the owner shall record the certificate in the Public Records in the Clerk of the Courts Office. This process shall apply retroactively to special family lots previously created under the Land Development Regulations.

Any decision made by the Board of County Commissioners is subject to a 30 day appeal period as outlined in Article 12 of the Land Development Regulations. Any action taken by the applicant within the 30 day appeal period is at the applicant's risk. No Certificate of Occupancy shall be issued until the 30 day appeal period is over or until any appeal has been settled.

Upon the applicant obtaining a Certificate of Occupancy, the applicant must file for Homestead Exemption. Homestead Exemptions can be filed each year with the Columbia County Property Appraiser's Office from January 1 to March 31.

**Once an application is submitted and paid for, a completeness review will be done to ensure all the requirements for a complete application have been met. If there are any deficiencies, the applicant will be notified in writing. If an application is deemed to be incomplete, it may cause a delay in the scheduling of the application before the Planning & Zoning Board.**

THE APPLICANT ACKNOWLEDGES THAT THE APPLICANT OR AGENT MUST BE PRESENT AT THE PUBLIC HEARING BEFORE THE PLANNING AND ZONING BOARD, AS ADOPTED IN THE BOARD RULES AND PROCEDURES, OTHERWISE THE REQUEST MAY BE CONTINUED TO A FUTURE HEARING DATE.

I hereby certify that all of the above statements and statements contained in any documents or plans submitted herewith are true and accurate to the best of my knowledge and belief.

Delbert Laxton

Elizabeth Laxton

Applicant/Agent Name (Type or Print)

D- Delbert Laxton

E- Elizabeth Laxton

2-10-17

Applicant/Agent Signature

Date

## FAMILY RELATIONSHIP AFFIDAVIT

STATE OF FLORIDA  
COUNTY OF COLUMBIA

BEFORE ME the undersigned Notary Public personally appeared, Delbert & Elizabeth Laxton the Owner of the parent parcel which has been subdivided for and Gary W. Laxton Jr, the Immediate Family Member of the Owner, which is intended for the Immediate Family Members primary residence use. The Immediate Family Member is related to the Owner as Grand Son. Both individuals being first duly sworn according to law, depose and say:

1. Affiant acknowledges Immediate Family Member is defined as parent, grandparent, step-parent, adopted parent, sibling, child, step-child, adopted child or grandchild.
2. Both the Owner and the Immediate Family Member have personal knowledge of all matters set forth in this Affidavit.
3. The Owner holds fee simple title to certain real property situated in Columbia County, and more particularly described by reference with the Columbia County Property Appraiser Parent Tract Tax Parcel No. 21-55-17-09313-000
4. The Immediate Family Member holds fee simple title to certain real property divided from the Owners' parent parcel situated in Columbia County and more particularly described by reference to the Columbia County Property Appraiser Tax Parcel No. 21-55-17-09313-002.
5. No person or entity other than the Owner and Immediate Family Member to whom permit is being issued, including persons residing with the family member claims or is presently entitled to the right of possession or is in possession of the property, and there are no tenancies, leases or other occupancies that affect the property.
6. This Affidavit is made for the specific purpose of inducing Columbia County to recognize a family division for an Immediate Family Member being in compliance with the density requirements of the Columbia County's Comprehensive Plan and Land Development Regulations (LDR's).
7. This Affidavit and Agreement is made and given by Affiants with full knowledge that the facts contained herein are accurate and complete, and with full knowledge that the penalties under Florida law for perjury include conviction of a felony of the third degree.

We Hereby Certify that the facts represented by us in this Affidavit are true and correct and we accept the terms of the Agreement and agree to comply with it.

Elizabeth Laxton  
Elizabeth Laxton  
Owner

Gary W. Laxton Jr  
Immediate Family Member

Delbert Laxton  
Typed or Printed Name  
Elizabeth Laxton

Gary W. Laxton Jr  
Typed or Printed Name

Subscribed and sworn to (or affirmed) before me this 10 day of feb, 2017, by Both Names Above (Owner) who is personally known to me or has produced FL DL / FL DL as identification.

[Signature]  
Notary Public



Subscribed and sworn to (or affirmed) before me this 10 day of feb, 2017, by Gary Laxton Jr (Family Member) who is personally known to me or has produced FL DL as identification.

[Signature]  
Notary Public



APPROVED:  
COLUMBIA COUNTY, FLORIDA



By: [Signature]  
Name: Laurie Hodson  
Title: Office Manager

# Columbia County Property Appraiser

updated: 2/1/2017

## 2016 Tax Year

Tax Collector Tax Estimator Property Card

Parcel List Generator

Parcel: 21-5S-17-09313-000

<< Next Lower Parcel Next Higher Parcel >>

2016 TRIM (pdf)

Interactive GIS Map

Print

Search Result: 1 of 1

<b>Owner's Name</b>	LAXTON DELBERT & ELIZABETH J		
<b>Mailing Address</b>	1973 SW MIXSON RD LAKE CITY, FL 32024		
<b>Site Address</b>	1973 SW MIXSON RD		
<b>Use Desc. (code)</b>	MOBILE HOM (000202)		
<b>Tax District</b>	3 (County)	<b>Neighborhood</b>	21517
<b>Land Area</b>	4.500 ACRES	<b>Market Area</b>	02
<b>Description</b>	NOTE: This description is not to be used as the Legal Description for this parcel in any legal transaction. BEG SW COR OF NW1/4 OF NW1/4, RUN E 462 FT, N 672 FT, W 243 FT, S 250 FT, W 219 FT, S 422 FT TO POB, EX 1.40 AC DESC ORB 892-462. ORB 391-70, 451-414,		

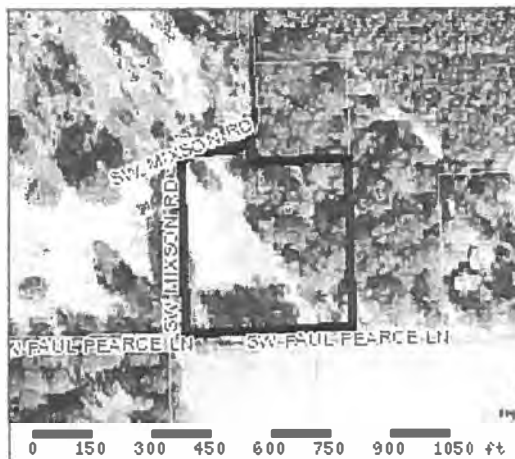

<b>Mkt Land Value</b>	cnt: (0)	\$21,435.00
<b>Ag Land Value</b>	cnt: (2)	\$0.00
<b>Building Value</b>	cnt: (1)	\$5,797.00
<b>XFOB Value</b>	cnt: (2)	\$1,500.00
<b>Total Appraised Value</b>		\$28,732.00
<b>Just Value</b>		\$28,732.00
<b>Class Value</b>		\$0.00
<b>Assessed Value</b>		\$26,682.00
<b>Exempt Value</b>	(code: HX H3)	\$25,000.00
<b>Total Taxable Value</b>		Cnty: \$1,682 Other: \$1,682   Schl: \$1,682

<b>Mkt Land Value</b>	cnt: (0)	\$21,435.00
<b>Ag Land Value</b>	cnt: (2)	\$0.00
<b>Building Value</b>	cnt: (1)	\$5,913.00
<b>XFOB Value</b>	cnt: (2)	\$1,500.00
<b>Total Appraised Value</b>		\$28,848.00
<b>Just Value</b>		\$28,848.00
<b>Class Value</b>		\$0.00
<b>Assessed Value</b>		\$27,242.00
<b>Exempt Value</b>	(code: HX H3)	\$25,000.00
<b>Total Taxable Value</b>		Cnty: \$2,242 Other: \$2,242   Schl: \$2,242

**NOTE: 2017 Working Values are NOT certified values and therefore are subject to change before being finalized for ad valorem assessment purposes.**

Show Similar Sales within 1/2 mile

Sale Date	OR Book/Page	OR Code	Vacant / Improved	Qualified Sale	Sale RCode	Sale Price
NONE						

Bldg Item	Bldg Desc	Year Blt	Ext. Walls	Heated S.F.	Actual S.F.	Bldg Value
2	MOBILE HME (000800)	1974	WD ON PLY (08)	1290	1686	\$5,913.00
<b>Note:</b> All S.F. calculations are based on exterior building dimensions.						

Code	Desc	Year Blt	Value	Units	Dims	Condition (% Good)
0294	SHED WOOD/	2012	\$1,000.00	0000001.000	0 x 0 x 0	(000.00)
0296	SHED METAL	2012	\$500.00	0000001.000	0 x 0 x 0	(000.00)



09313-000

This instrument was prepared by:

Prepared by *[Signature]*  
LAKELAND, FLORIDA 33035

# Warranty Deed

(STATUTORY FORM — SECTION 689.02 F.S.)

This Indenture, Made this 23<sup>rd</sup> day of November 19 77, Between  
ELLIS PEARCE and his wife, LORETTA PEARCE  
of the County of Columbia, State of Florida, grantor, and  
DELBERT LAXTON and his wife, ELIZABETH J. LAXTON  
whose post office address is Rt. 2, Box 43B, Lake City  
of the County of Columbia, State of Florida, grantee,

**Witnesseth**, That said grantor, for and in consideration of the sum of TEN AND NO/100 (10.00)-----  
----- Dollars,  
and other good and valuable considerations to said grantor in hand paid by said grantee, the receipt whereof is hereby  
acknowledged, has granted, bargained and sold to the said grantee, and grantee's heirs and assigns forever, the fol-  
lowing described land, situate, lying and being in Columbia County, Florida, to-wit:

Begin at the SW Corner of the NW 1/4 of NW 1/4 of Section 21,  
Township 5 South, Range 17 East, and run East along the  
South Line of said NW 1/4 of NW 1/4 462 feet, thence run North  
422 feet, thence run West 462 feet, thence run South along  
West Line of said NW 1/4 of NW 1/4, 422 feet to the Point of  
Beginning, containing 4 1/2 acres, more or less.



391 PAGE 70  
OFFICIAL RECORDS

NOV 23 11:14  
391 PAGE 70  
778 646

and said grantor does hereby fully warrant the title to said land, and will defend the same against the lawful claims  
of all persons whomsoever.

\* "Grantor" and "grantee" are used for singular or plural, as context requires.

**In Witness Whereof**, Grantor has hereunto set grantor's hand and seal the day and year first above written.  
Signed, sealed and delivered in our presence:

*[Signature]*  
*[Signature]*

*[Signature]* (Seal)  
ELLIS PEARCE  
*[Signature]* (Seal)  
LORETTA PEARCE

STATE OF FLORIDA  
COUNTY OF COLUMBIA

I HEREBY CERTIFY that on this day before me, an officer duly qualified to take acknowledgments, personally  
appeared ELLIS PEARCE and his wife, LORETTA PEARCE

to me known to be the persons described in and who executed the foregoing instrument and acknowledged before  
me that they executed the same.

WITNESS my hand and official seal in the County and State last aforesaid this 23<sup>rd</sup> day of November  
19 77.

*[Signature]*  
Notary Public

My commission expires:





09313-002

This Instrument Prepared by & return to:  
Name: WAYNE LAXTON  
Address: 163 SE WOODHAVEN STREET  
LAKE CITY, FLORIDA 32025  
Parcel I.D. #: 09313-000

Inst: 201712081543 Date: 01/25/2017 Time: 4:34PM  
Page 1 of 2 B: 1329 P: 2013, P.DeWitt Casson, Clerk of Court  
Columbia, County, By: BD  
Deputy Clerk/Doc Stamp/Deed: 0.70

SPACE ABOVE THIS LINE FOR PROCESSING DATA

SPACE ABOVE THIS LINE FOR RECORDING DATA

**This Quit-Claim Deed** executed this 23<sup>rd</sup> day of **January**, A.D. 2017, by **DELBERT LAXTON and ELIZABETH J. LAXTON, HIS WIFE**, first party, to **WAYNE LAXTON, A MARRIED MAN**, whose post office address is **163 SE WOODHAVEN STREET, LAKE CITY, FL 32025**, second party:

(Wherever used herein, the terms "first party" and "second party" shall include singular and plural heirs, legal representatives, and assigns of individuals, and the successors and assigns of corporations wherever the context so admits or requires.)

**WITNESSETH**, That the said first party, for and in consideration of the sum of \$10.00, in hand paid by the said second party, the receipt whereof is hereby acknowledged, does hereby remise, release, and quit-claim unto the said second party forever, all the right, title, interest, claim and demand which the said first party has in and to the following described lot, piece or parcel of land, situate, lying and being in the **County of Columbia, State of Florida**, to-wit:

**See Attached Exhibit "A"**

**THIS QUIT CLAIM DEED WAS PREPARED WITHOUT THE BENEFIT OF A TITLE SEARCH OR SURVEY AND MAKES NO WARRANTIES AGAINST SAME.**

**To Have and to Hold** the same, together with all and singular the appurtenances thereunto belonging or in anywise appertaining, and all the estate, right, title, interest, lien, equity and claim whatsoever of the said first party, either in law or equity, to the only proper use, benefit and behoof of the said second party forever.

**In Witness Whereof**, the said first party has signed and sealed these presents the day and year first above written.

Signed, sealed and delivered in the presence of:

[Signature]  
Witness Signature

Maeda M. Condon  
Printed Name

[Signature]  
Witness Signature

Tyler Rogers  
Printed Name

[Signature] L.S.  
DELBERT LAXTON

Address:  
1973 SW MIXSON RD, LAKE CITY, FL 32024

[Signature] L.S.  
ELIZABETH J. LAXTON

Address:  
1973 SW MIXSON RD, LAKE CITY, FL 32024

STATE OF FLORIDA  
COUNTY OF COLUMBIA

The foregoing instrument was acknowledged before me this 23<sup>rd</sup> day of **January**, 2017, by **DELBERT LAXTON and ELIZABETH J. LAXTON**, who are known to me or who have produced Driver's License as identification.

[Signature]  
Signature of Notary  
My commission expires \_\_\_\_\_

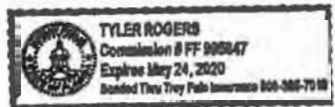

**DESCRIPTION:**

**BEGIN AT THE SW CORNER OF THE NW 1/4 OF THE NW 1/4 AND RUN N.89°58'44"E., ALONG THE SOUTH LINE OF SAID NW 1/4 OF NW 1/4, 462.00 FEET; THENCE N.01°11'20"E, 189.04 FEET; THENCE S.89°58'44"W., 462.04 FEET TO THE WEST LINE OF SAID NW 1/4 OF NW 1/4; THENCE S.01°10'41"W., ALONG SAID WEST LINE, 189.04 FEET TO THE POINT OF BEGINNING. CONTAINING 2.00 ACRES, MORE OR LESS.**









# 3

**COLUMBIA COUNTY BOARD OF COUNTY COMMISSIONERS  
AGENDA ITEM REQUEST FORM**

The Board of County Commissioners meets the 1st and 3rd Thursday of each month at 5:30 p.m. in the Columbia County School Board Administrative Complex Auditorium, 372 West Duval Street, Lake City, Florida 32055. All agenda items are due in the Board's office one week prior to the meeting date.

Today's Date: February 22, 2017

Meeting Date: March 2, 2017

Name: Tom Brazil

Department: Combined Emergency Communications Center

Division Manager's Signature: \_\_\_\_\_

**1. Nature and purpose of agenda item:**

**Request to apply for Spring 2017 E-911 Board Rural Grant for 911 Support & Maintenance in the amount of \$67,210.00**

Attach any correspondence information, documents and forms for action i.e., contract agreements, quotes, memorandums, etc.

**2. Fiscal impact on current budget.**

Is this a budgeted item?

N/A

Yes Account No. 001-2510-525.30-34

No Please list the proposed budget amendment to fund this request

Budget Amendment Number: \_\_\_\_\_

Fund: \_\_\_\_\_

FROM: \_\_\_\_\_

TO: \_\_\_\_\_

AMOUNT: \_\_\_\_\_

**For Use of County Manger Only:**

Consent Item

Discussion Item



*COLUMBIA COUNTY, FLORIDA  
COMBINED COMMUNICATIONS CENTER 9-1-1  
263 NW LAKE CITY AVE.  
LAKE CITY, FL 32055  
(386) 758-1125  
FAX (386) 758-1386*

## **MEMORANDUM**

DATE: February 22, 2017

TO: Ben Scott County Manager via Scott Ward Assistant County Manager

FR: Thomas W. Brazil Combined Communications Center Director / 911 Coordinator

RE: Request to BOCC to apply for E-911 Board Spring 2017 Grant

---

Attached is the application and supporting documents to apply for the 2017 E-911 Board Rural Spring Grant for support & maintenance of the County 911 call taking equipment. The amount of this reimbursement grant is \$67,210.00. Via this memorandum, I am seeking BOCC approval to apply for this grant.

Properly maintaining our 911 equipment provides resiliency, reliability, and survivability of our 911 call taking equipment to serve the citizens of Columbia County.

cc: file

**APPLICATION**

**E911 RURAL COUNTY GRANT  
PROGRAM**

**W Form 1A, incorporated by reference in Rule 60FF1-5.002, Florida  
Administrative Code, Rural County Grants  
E911 Rural County Grant Program Application,  
Revised 02/17/16**

## 1.0 Purpose

The E911 Rural County Grant Program is to assist rural counties with the installation and maintenance of an Enhanced 911 (E911) system and to provide “seamless” E911 throughout the State of Florida.

## 2.0 Eligibility

The Board of County Commissioners in any county in the State of Florida with a population of less than 75,000 as per the most recent published data from the Florida Association of Counties’ directory is eligible to apply for this grant program. Funding priorities are established in Addendum I.

## 3.0 Definitions

- A. Enhanced 911 (E911): As defined by subsection 365.172(3)(h), Florida Statutes, and as referenced in the State E911 Plan under section 365.171, Florida Statutes.
- B. E911 Maintenance: Means the preventative, routine and emergency maintenance required by the State E911 Plan, in order to maintain the E911 System in operable working condition.
- C. E911 System: Means the Public Safety Answering Point equipment, in accordance with the State E911 Plan, including 911 call routing, processing, mapping and call answering communications equipment.
- D. Next Generation 911 (NG-911): Means the designation for an advanced 911 emergency communications system or service that provides a communications service subscriber with 911 service and, in addition, directs 911 emergency requests for assistance to appropriate public safety answering points based on the geographical location from which the request originated, or as otherwise provided in the State E911 Plan under Section 365.171, Florida Statutes, and that provides for automatic number identification and automatic location identification features and emergency data information through managed IP-based networks.
- E. Public Safety Answering Point (PSAP): As defined by paragraph 365.172(3)(y), Florida Statutes, and as referenced in the State E911 Plan under section 365.171, Florida Statutes.

## 4.0 E911 Rural County Grant Program Calendar

	Spring Schedule	Fall Schedule
Counties submit Application	by April 1	by October 1
E911 Board Members evaluate applications	April – May	October – November
E911 Board votes on applications to fund at regularly scheduled meeting	April – June	October – December
E911 Board sends notification of awards approved for funding to the counties.	before June 30	before December 30
Implementation period	One year from the award notification letter date.	One year from the award notification letter date.
Expiration of the right to incur costs, request payment and/or final reimbursement of funding.	Two years from the award notification letter date	Two years from award notification letter date.

## 5.0 General Conditions

- 5.1 Applications must be delivered to the following address:  
State of Florida E911 Board  
ATTN: E911 Board Administrative Staff  
4030 Esplanade Way, Suite 135  
Tallahassee, FL 32399-0950  
Or [E911BoardElectronicGrantReports@dms.myflorida.com](mailto:E911BoardElectronicGrantReports@dms.myflorida.com)
- 5.2 The applicant must provide one original of the pages for Application Form items 1 through 14 the associated quotes, and the E911 Board Form 6A, "County E911 Fiscal Information," included in E911 Board Rule 60FF1-5.006, Florida Administrative Code. The grant application package must be postmarked or delivered on or before April 1 or October 1 of each year, dependent on the spring or fall application period. Failure to provide these documents will result in automatic rejection of the grant application. One scanned copy of the entire submitted package should also be provided on a CD-ROM, to ensure quality of the documents to be reviewed.
- 5.3 The E911 Board will consider remotely provided hosted 911 answering point call-taking equipment and network services directly attributable to establishing and provisioning E911 or NG-911 services. Warranty and maintenance costs shall be calculated to account for only the first year warranty and maintenance costs and shall not include upfront maintenance costs to reduce the yearly service amount.
- 5.4 All grant applications shall be accompanied by at least one complete quote for equipment or services. Grant applications totaling \$35,000.00 or more must be accompanied by at least three written substantiated competitive complete quotes from different vendors. Complete quote submittals shall include a detailed scope of work, all pages included in the vendor proposal, breakdown of all costs including equipment, service tasks and deliverables. The E911 Board will compare the three quotes to any existing state contract in order to determine appropriate funding. Any county that has made a good faith effort to obtain at least three competitive quotes and has not been able to obtain the quotes can request E911 Board review based on substantiated proof of request for quotes or posting of the request with documentation of the limited responses.
- 5.5 If the grant application does not exceed the threshold amount of \$195,000, the county can initiate a request for approval for sole source funding. These will be considered on a case-by-case basis. Justification for sole source funding shall be provided with the application. Sole source will be approved if provided in accordance with Chapter 287, Florida Statutes, or with provision of a letter from the county's purchasing department that the project is a sole source procurement based on the county's purchasing requirements, which shall be provided with this grant application. Include pricing justification in the sole source letter from the county's purchasing department.
- 5.6 Rather than submitting multiple application requests for maintenance, all eligible maintenance requests should be combined into a single application request and include a breakdown of the individual components of the E911 system maintenance costs that are requested for funding assistance in the application. Grant applications for maintenance, where the county obtained a grant or utilized county funds to purchase equipment and obtained three competitive quotes for the first year of maintenance, or met the requirements of General Conditions items 5.4 or 5.5, are not required to provide three written quotes with an application for an additional year of maintenance.



- 5.7 All maintenance requests should include on the vendor's quote for service the beginning and ending term for each maintenance request. Grant awards will be limited to maintenance contracts beginning prior to or within the maintenance cycle of the grant program. Spring cycle maintenance requests should be submitted for maintenance beginning May through October. Fall cycle maintenance requests should be submitted for maintenance beginning November through April. Complete quote shall include a detailed scope of work, all pages included in the vendor proposal, breakdown of all costs including equipment, service tasks and deliverables.
- 5.8 Applicants requesting items from different funding priorities should complete a separate application for each priority. See Addendum I - Funding Priorities for the E911 Rural County Grant Program for a listing of funding priorities. Items from the same funding priorities should be combined in the same application and shall comply with General Condition items 5.4 and 5.5.
- 5.9 Should two or more rural counties jointly apply for a grant, each county will be required to complete and submit a grant application detailing the funds requested and the county responsible for the funds. In addition one combined grant application detailing the entire project and a memorandum of understanding or inter-local agreement of all counties involved shall be submitted. The combined grant application shall comply with General Condition items 5.4 and 5.5.
- 5.10 Procurement shall be based on the county's purchasing requirements and the applicable State purchasing requirements, including Section 112.061, Florida Statutes. All travel and associated per diem costs proposed shall be in compliance with General Conditions item 6.3.5.
- 5.11 Funding application requests must include a scope of work that clearly establishes the tasks to be performed. The applications shall include all tasks that are required for successful completion of the project. The project shall be divided into quantifiable units of deliverables that shall be received and accepted in writing by the county before payment. Each deliverable must be directly related to the scope of work and must specify the required minimum level of service to be performed and the criteria for evaluating the successful completion of each deliverable.
- 5.12 Funding requests must include all necessary costs required for full implementation of the proposed solution including that of any third party. Should the county grant application request or grant award be less than the projected cost of the equipment or service, the county should provide verification of the ability to fund the difference. Pricing submitted cannot be contingent upon "yet to be" determined fees for products and services by the proposer or any other third party required for implementation.
- 5.13 The county shall provide information on the county's preceding year E911 fee revenue amount, the preceding year carry forward funding amount and the total carry forward balance amount in the county E911 fund. The amount of grant funding award, for allowable carry forward expenditures, is limited based on the total amount of carry forward funding in the county E911 fund in excess of an amount calculated based on the allowable 30 percent carry forward amount for a two year basis in accordance with sub-paragraph 365.172(6)(a)3.c., Florida Statutes and E911 Board Rule 60FF1-5.006 Florida Administrative Code. The county shall include the amount of their county carry forward funding being utilized for this grant in the Applied County Carry Forward or other Funding (if applicable) line in the Application Form item #12. Budget/Expenditure Report. This carry forward funding provision does not apply to grant applications for recurring maintenance. Maintenance contract cost is not a capital expenditure and is not an authorized expenditure of carry forward funds after the initial first year project costs included in the original capital equipment replacement or upgrade project.

- 5.14 Detailed information is required for any grant application requesting funding for systems that require immediate system replacement for provisioning of enhanced 911 in the county. Include detailed justification and explanation for any E911 system with an expected remaining life of less than 1 year.
- 5.15 Funding requests contingent upon “beta testing” or for products and services not in general production and installation will not be funded.

**6.0 Limitation on Use of Funds**

- 6.1 Only eligible expenses for E911 service listed in subsection 365.172(10), Florida Statutes, (Appendix I) that are not specifically excluded in this application will be funded.
- 6.2 Specifically excluded E911 expenses:
  - 6.2.1 Salaries and associated expenses for 911 coordinators and call takers or other 911 personnel will not be funded.
  - 6.2.2 Wireline database costs from the local exchange carrier, vehicle expenses, outside plant fiber or copper cabling systems and building entrance build out costs, consoles, workstation furniture and aerial photography expenses will not be funded.
  - 6.2.3 Wireline 911 analog trunks, administrative lines and circuits are not fundable. Recurring network and circuit costs will not be funded after the first year implementation period.
- 6.3 Funding limitations are specified on the following items:
  - 6.3.1 Grant funding shall be limited to eligible equipment maintenance and warranty costs for a primary PSAP and one other PSAP per county; either a primary, a secondary or a backup.
  - 6.3.2 Grant funding shall be limited to eligible mapping maintenance and warranty costs for a primary PSAP and one other PSAP per county; either a primary, a secondary or a backup.
  - 6.3.3 Grant funding for 911 equipment, hardware and software shall be limited (per grant cycle) to eligible expenditures for a primary PSAP only.
  - 6.3.4 Selective router equipment costs are limited to the primary PSAP system and are limited to one per county. For this grant program they are included under the call handling equipment priority.
  - 6.3.4 Training cost funding is limited to new system & equipment training.
  - 6.3.5 The allowable grant funding for travel expenses is limited to the authorized amounts established in Section 112.061, Florida Statutes, and the Department of Financial Services Guidelines for State Expenditures. Allowable costs for daily per diem shall not exceed \$186.00.

**7.0 Approval and Award**

- 7.1 The E911 Board will review each application for compliance with the requirements of terms and conditions.

- 7.2 Grant awards will be withheld for any county that has a grant with a past-due quarterly report or past-due final documentation and closeout of previous rural county grant awards.
- 7.3 Applications will be awarded based upon the priorities set by the E911 Board as listed in Addendum I - Funding Priorities for the E911 Rural County Grant Program.
- 7.4 The E911 Board will adjust the amount awarded to a county based upon the availability of funds, eligibility of requested items, published quotes, increased effectiveness of grant funds, minimum system requirements for performing the needed E911 function as specified in the State E911 Plan, or documented factors provided in the grant application submission.
- 7.5 Any county that requires Board of County Commissioner approval of the grant program funding, prior to commencement of the project, shall notify the E911 Board in Application Form item #10. Grant funds for approved grant applications will be held until the county provides written notification to the E911 Board of the Board of County Commissioners approval of the project prior to the funds being disbursed from the E911 Trust Fund.
- 7.6 Any conditional hold, for documentation submittal referenced in 7.2 and 7.5, is limited to the last regularly scheduled E911 Board meeting application vote established in the grant program calendar.

**8.0 Financial and Administrative Requirements**

- 8.1 Grant funds shall be provided on a cost reimbursement basis. Grant funds shall be deposited in an interest bearing account maintained by the grantee, and each grant shall be tracked using a unique accounting code designator for deposits, disbursements and expenditures assigned by the county. All grant funds in the account maintained by the grantee shall be accounted for separately from all other funds. Any interest generated shall be returned to the E911 Board.
- 8.2 Each grantee may submit reimbursement claims to the E911 Board as needed; however claims are limited to one request per month. Receipt of reimbursement funds from the E911 Board is contingent on the timely and accurate submittal of funding requests. Requests for reimbursement of expenditures must be submitted on the approved Appendix IV Financial Reimbursement of Expenditures Reporting Form. Incomplete claims forms or claims not submitted on the correct form cannot be processed and will be returned for corrections. Submit only for the amounts in each budget categories in which you have incurred expenditures.
- 8.3 Upon written request and accompanying documentation justifying the need, a county may receive a payment of funding with a completed Expenditures Reporting Form, with the vendor invoice, and county certification that the specific grant items including all tasks and deliverables included in the funding request are complete. Within 45 days of transfer of funding or the check date, the grantee shall submit verification of payment to the vendor.
- 8.4 Reimbursement claims shall include only expenditures claimed against the specific grant number awarded and include copies of purchase orders and paid vouchers, invoices, copies of check processing, journal transfers. To assure prompt processing, complete reimbursement claims should be e-mailed to:

[E911Board-ElectronicGrantReports@dms.myflorida.com](mailto:E911Board-ElectronicGrantReports@dms.myflorida.com)

- 8.5 Grant funds, can only be used between the beginning and ending dates of the grant term, unless the E911 Board authorizes an extension. The right to incur costs under this grant expires two years from receipt of award and funds. The grantee may not incur costs and request payment or final reimbursement of funding past the expiration date.
- 8.6 Responsibility for grant funding and any failure to perform the minimum level of service required by the grant application and the application scope of work cannot be transferred under any circumstances from the County. Failure to perform the scope of work or expenditure of funds for other than allowable 911 costs as stated in the grant application shall require the county to return the awarded funds to the E911 Board.
- 8.7 Responsibility for property and equipment obtained under a grant cannot be transferred under any circumstances. If a sale or transfer of such property or equipment occurs within five years after a grant ends, funds must be returned to the E911 Board on a pro rata basis.
- 8.8 The grantee agrees that any improvement, expansion or other effect brought about in whole or part by grant funds will be maintained for a minimum of five years or thereafter until the effective replacement date of the system.
- 8.9 If a grantee materially fails to comply with any term of an award, the Board shall take one or more of the following actions, as appropriate in the circumstances:

Temporarily withhold grant payments pending grantee correction of the deficiency,  
Disapprove all or part of the cost of the activity or action not in compliance,  
Suspend or terminate the current award for the grantee's project,  
Suspend or deny future grant awards.

The Board will provide the grantee an opportunity for a hearing, appeal, or other administrative proceeding to which the grantee is entitled under Florida Statute or regulation applicable to the action involved.

- 8.10 Grant awards may be terminated in whole or in part by the Board, with the consent of the grantee, in which case the two parties shall agree upon the termination conditions, including the effective date and in the case of partial termination, the portion to be terminated. Grant awards may be terminated by the grantee upon written notification to the Board, detailing the reasons for such termination, the effective date, and return of all funding.
- 8.11 Grant funds provided in excess of the amount to which the actual cost incurred to meet the terms and conditions of the grant agreement must be refunded to the E911 Board and sent to the Florida E911 Board's Post Office Box address:  
Florida E911 Board  
PO Box 7117  
Tallahassee, FL 32314  
The refund shall include transmittal information detailing the amount of returned funds that are excess grant funding and/or returned interest and shall include the number of the associated grant.

## **9.0 Grant Reporting Procedures**

- 9.1 Grantees will be required to submit quarterly reports summarizing cumulative expenditures and status of the grant project. Quarterly reports shall include an updated Application Form item #12 Budget/Expenditure Report and a completed Appendix III Quarterly Report Form.
- 9.1.1 Reporting will begin at the conclusion of the first full quarter after the award. The report periods will end on March 31, June 30, September 30, and December 31 of each year. Reports are due within 30 days of the ending report period.
- 9.1.2 Earned interest shall be reported cumulatively and included with each quarterly report.
- 9.1.3 Updated reports and associated information should be e-mailed to [E911Board-ElectronicGrantReports@dms.myflorida.com](mailto:E911Board-ElectronicGrantReports@dms.myflorida.com).
- 9.2 At project completion, a final report shall be submitted based on the same reporting requirements described in grant reporting item 9.1. The county shall determine the final completion date based on the final payment date, or the initiation date of the warranty period. Final documentation including copies of all expenditures and corresponding invoices shall be submitted within 90 days of the final report.
- 9.3 Change requests shall be submitted prior to deviation from any awarded grant applications. No changes or departures from the original request are authorized unless approved in writing by the E911 Board. Such requests shall be submitted using the form attached in Appendix II, Request for Change Form. Any unauthorized change shall require the return of grant funds, plus any interest accrued.
- 9.3.1 Time extension requests will not be granted unless the county has executed a contract for the grant equipment and/or services, or demonstrates good cause for failure to execute a contract within twelve months of award. Good cause documentation shall include a new project timeline schedule.
- 9.3.2 Time extensions shall be limited to a maximum of one additional year when approved by the E911 Board.
- 9.3.3 Request for Change forms and associated information should be e-mailed to [E911Board-ElectronicGrantReports@dms.myflorida.com](mailto:E911Board-ElectronicGrantReports@dms.myflorida.com).
- 9.4 The Appendix III Quarterly Report Form shall inform the E911 Board of significant impacts to grant supported activities. Significant impacts include project status developments affecting time schedules and objectives, anticipated lower costs or producing beneficial results in addition to those originally planned. Additionally, problems, delays, or adverse conditions which will materially impair the ability to meet the timely completion of the award must be reported. The disclosure must include a statement of the action taken, or contemplated, and any assistance needed to resolve the situation.
- 9.5 The county's Board of County Commission chairperson shall be notified when overdue quarterly reports or final reports are not received before the next E911 Board meeting following the month after the end of the quarter in which they are due.
- 9.6 Funding continuance will be based on timely submission of quarterly reports.

- 9.7 Final document submission and close-out of a grant does not affect the E911 Board's right to disallow costs and recover funds on the basis of an audit or financial review. The county shall remain obligated to return any funds expended that do not comply with the terms and conditions of the grant award.

County COLUMBIA

STATE OF FLORIDA E911 BOARD  
**E911 RURAL COUNTY GRANT PROGRAM APPLICATION FORM**

Total Amount Requested: \$67,210.00

Project Title: **MAINTENANCE & SUPPORT**

1. Board of County Commissioners Chair: Ronald Williams

Mailing Address: 135 N.E. Hernando Ave  
Mailing: P.O. Box 1529  
City: Lake City  
State: Florida Zip: 32056 - 1529  
Phone: ( 386 ) 758-1005 Fax (386) 758-2128  
Email Address: Penny\_stanley@columbiacountyfla.com

2. County 911 Coordinator: Thomas W. Brazil

Mailing Address: Columbia County Combined Communications Center 911  
263 N.W. Lake City Av.  
City: Lake City  
State: Florida Zip: 32055 - 1529  
Phone: (386) 758- 1388 Fax: 386 758-1386  
Email Address: tbrazil@columbiacountyfla.com

3. Federal Tax ID Number: 59-6000564

County COLUMBIA

**COUNTY INFORMATION**  
**USE 12 POINT FONT OR LEGIBLE HAND PRINTING**

4. County Fact Information

A. County COLUMBIA

B. Population 67,966

C. Total Number of Incoming Nonwireless Trunks 8

D. Total Number of Incoming Wireless Trunks 8

E. Number of PSAP's 1

F. Number of Call-taking Positions per PSAP Primary 9 Auxiliary (Side B) 4 for total of 13

G. Total Volume of 911 Calls \_\_\_\_\_

H. What equipment is needed to maintain the Enhanced 911 system?

Maintenance & Support

I. What equipment is requested in this grant application?

Maintenance & Support

J. Financial Information:

1.) What are the current annual costs for your E911 system (circuits, customer records hardware and software, etc.) not including maintenance?

\$570,826.75

2.) What are the current annual costs for maintenance of items included in 1.)?

\$67,210.00

3.) Total amount of E911 fee revenue received in the preceding year?

\$249,093.61

4.) Total amount of county carry forward funding retained in the preceding year?

\$0.0

5.) Current total amount of county carry forward funding?

\$0.0

6.) Two year maximum calculated amount for applied carry forward funding

Calculation (current year carry forward \$0.0

funding amount based on General

Condition 5.13 multiplied by two)

7.) Minimum calculated amount for Applied Carry Forward Funding

Calculation (amount in J.5. subtracted by \$0.0

amount in J.6.)

Insert in Item 12. Budget Expenditure Report \_\_\_\_\_



5. Describe your county's existing E911 system. Include specific information on existing system equipment upgrades and when the installation of this equipment was completed.

*Columbia County operates a Type 4 Enhanced 911 System with state of the art geo-diverse, Airbus DS Communications VESTA 911 equipment which was installed May 31, 2015. It includes a nine (9) position primary PSAP center and, as the County Center is the only PSAP in Columbia County, a four (4) position side B Auxiliary PSAP designed and engineered to provide redundancy and minimize the chances of a total 911 system outage. The County also utilizes two (2) Exacom G2 Time Gate logging recorders, installed in July 2012 and 2013 respectively. AT&T provides the 911 circuits, ANI/ALI data, MSAG, and selective routing services.*

6. Describe the scope of work for the proposed project including any goal(s) and objectives. Include the tasks to be performed as part of the project. Provide scope of work in quantifiable units of deliverables that shall be received and accepted. For each deliverable specify the required minimum level of service to be performed and the criteria for evaluating the successful completion of each deliverable.

*Columbia County's E-911 system is maintained under contract with AK Associates and this grant is seeking funds to renew that contract to include:*

*Exacom 911 logging recorder support (7/1/2017 - 6/30/2018) is needed to maintain the 911 logging recorders. Includes comprehensive 24/7 technical maintenance support program including support, patches and upgrades to all software components as well as hardware repairs.*

*Airbus DS Communications VESTA 911 VN server bundle as well as Orion DataSync host support and Orion DataSync client support are needed to maintain & support the VESTA 911 call taking equipment. Airbus VESTA support V-server, VESTA SPT prime, VESTA 911 Modules maintenance & support, VESTA peripherals & gateways maintenance & support. VESTA Analytics maintenance & support, VESTA Locate maintenance & support and Orion DataSync VESTA managed services & support. Fortinet Firewall maintenance, support & updates for the period of 6/1/2017 through 5/31/2018. All are needed to maintain the 911 call taking equipment.*

*The goal of this grant project is to renew and continue the maintenance and support of the above listed Airbus DS Communications products to set to expire May 31, 2017 as well as renew support agreement for Exacom to insure the continued functionality of the E-911 system in Columbia County.*

The scope of work includes Airbus DS Communications VESTA software, managed services, Fortinet firewall support, and help desk support of the 911 CPE as well as (Exacom) software and hardware support for the logging recorders. The goal of this grant project is to renew the maintenance and support agreements to insure the continued functionality of the E911 system in Columbia County. AK Associates provides first tier routine and emergency maintenance for the E911 system and logging recorder.

Should technical support be needed from equipment manufacturer, the AK technician will act as the point of contact and agent for Columbia County.

The project is as follows:

- Software patches, fixes, upgrades and Tier II maintenance support on Airbus equipment.
- Software patches, hardware support, fixes, upgrades and Tier II maintenance support on Exacom equipment.

The maintenance support will be monitored and reviewed monthly with the vendor to assure the level of service is provided and the system is being maintained in operable working conditions.

**Note: for further description see scope of work and contract decryption in attachments from AK Associates**

7. Justification of the need for the proposed project. Provide detailed information on the existing system's condition including a detailed justification for any system with an expected remaining life of less than 1 year.

*Without the Airbus DS Communications and Exacom logging recorder support, Columbia County would not be able to effectively maintain the County's E-911 system.*

8. Describe why your county will not be able to complete this project without this grant funding.

*In section 4.4 of the State E-911 Plan, coordinators are required to develop and maintain plans to limit the impact of system failures and expedite restoration of E-911 services. Our comprehensive equipment maintenance agreement currently in place with AK Associates addresses this requirement. It is our goal to continue to provide reliable, uninterrupted 911 services. The grant funding will provide the equipment maintenance and emergency repair resources necessary to ensure operation of our E-911 system.*

9. Briefly describe how this grant project would be in concurrence with the State E911 Plan.

*Columbia County currently contracts with AK Associates for E-911 system service and maintenance. We need these funds to renew the Airbus DS Communications VESTA equipment & Fortinet Firewall for period of 6/1/2017 through 5/31/2018.*

*In addition we will renew Exacom Recorder Second Tier Support for 7/1/2017 through 06/30/2018.*

*Receipt of these funds will allow continuance of our current maintenance contracts without interruption or lapse in maintenance coverage.*

10. Describe the required steps with an anticipated time schedule with procurement and payment milestones and a total project completion date.

*Columbia County will renew the Airbus DS Communications VESTA equipment for the period of 6/1/2017 through 5/31/2018. In addition we will renew Exacom Recorder Second Tier Support for period 7/1/2017 through 6/30/2018.*

11. Sole source justification (if applicable).

*This will be a sole source procurement in compliance with Columbia County's purchasing policies avoid voiding any existing maintenance and warranty agreements.*

12. Budget/Expenditure Report

Prepare an itemized Grant Budget ("Line Item" breakdown should include separated systems, i.e.; 911 system, logging recorder, centerline mapping, etc. and services items). The completed form shall be used to complete quarterly report requirements, listing expenditures and revisions (if any) in appropriate columns. If there is insufficient space, please include details in an attachment. **Budget costs should match requested vendor quote.**

County:	COLUMBIA	Grant Number:		Report Date:	
---------	----------	---------------	--	--------------	--

For Grant Period Ending:	<input type="checkbox"/> March 31	<input type="checkbox"/> June 30	<input type="checkbox"/> September 30	<input type="checkbox"/> December 31	Year:		FINAL	<input type="checkbox"/>
--------------------------	-----------------------------------	----------------------------------	---------------------------------------	--------------------------------------	-------	--	-------	--------------------------

Proposed Budget				USE FOR QUARTERLY REPORTS	
Line Item	Unit Price (\$)	Quantity	Total Cost (\$)	Revised Budget	Total Cumulative Expenditures (\$)
A. Systems (Hardware, Software, Equipment & Labor)					
Total System Items					
B. Services (Training, Maintenance and Warranty Items)					
Fortinet Firewall Support	\$303.95	1	\$303.95		
Airbus Vista 911 Support Side A 6/1/17-5/31/18	\$24,279.00	1	\$24,279.00		
Airbus Vista 911 Support Side B 6/1/17-5/31/18	\$11,371.00	1	\$11,371.00		
AK Associates Elite Premier Maintenance 6/1/17-5/31/18	\$28,430.00	1	\$28,430.00		
Exacon Second Tier Support 7/1/17-6/30/18	\$2,827.00	1	\$2,827.00		
Total Service Items			\$67,210.00		
Less any Applied County Carry Forward or other Funding (if applicable)			0.0		
Grant Request Total			\$67,210.00		

USE FOR ALL REPORTS	
Total Amount of Grant Awarded	
Total Interest for Grant Period	
Final Completion Date	

\_\_\_\_\_  
Signature, County 911 Coordinator



## Appendix I

### **NO requests for funding will be acknowledged for any items not specified in subsection 365.172 (10), Florida Statutes (shown below).**

#### AUTHORIZED EXPENDITURES OF E911 FEE.—

(a) For purposes of this section, E911 service includes the functions of database management, call taking, location verification, and call transfer. Department of Health certification and recertification and training costs for 911 public safety telecommunications, including dispatching, are functions of 911 services.

(b) All costs directly attributable to the establishment or provision of E911 service and contracting for E911 services are eligible for expenditure of moneys derived from imposition of the fee authorized by subsections (8) and (9). These costs include the acquisition, implementation, and maintenance of Public Safety Answering Point (PSAP) equipment and E911 service features, as defined in the providers' published schedules or the acquisition, installation, and maintenance of other E911 equipment, including circuits; call answering equipment; call transfer equipment; ANI or ALI controllers; ANI or ALI displays; station instruments; E911 telecommunications systems; visual call information and storage devices; recording equipment; telephone devices and other equipment for the hearing impaired used in the E911 system; PSAP backup power systems; consoles; automatic call distributors, and interfaces, including hardware and software, for computer-aided dispatch (CAD) systems; integrated CAD systems for that portion of the systems used for E911 call taking; GIS system and software equipment and information displays; network clocks; salary and associated expenses for E911 call takers for that portion of their time spent taking and transferring E911 calls, salary, and associated expenses for a county to employ a full-time equivalent E911 coordinator position and a full-time equivalent mapping or geographical data position, and technical system maintenance, database, and administration personnel for the portion of their time spent administrating the E911 system; emergency medical, fire, and law enforcement prearrival instruction software; charts and training costs; training costs for PSAP call takers, supervisors, and managers in the proper methods and techniques used in taking and transferring E911 calls, costs to train and educate PSAP employees regarding E911 service or E911 equipment, including fees collected by the Department of Health for the certification and recertification of 911 public safety telecommunicators as required under s. [401.465](#); and expenses required to develop and maintain all information, including ALI and ANI databases and other information source repositories, necessary to properly inform call takers as to location address, type of emergency, and other information directly relevant to the E911 call-taking and transferring function. Moneys derived from the fee may also be used for next-generation E911 network services, next-generation E911 database services, next-generation E911 equipment, and wireless E911 routing systems.

(c) The moneys may not be used to pay for any item not listed in this subsection, including, but not limited to, any capital or operational costs for emergency responses which occur after the call transfer to the responding public safety entity and the costs for constructing, leasing, maintaining, or renovating buildings, except for those building modifications necessary to maintain the security and environmental integrity of the PSAP and E911 equipment rooms.



**Appendix III**

**Quarterly Report**

County: \_\_\_\_\_  
Grant Number: \_\_\_\_\_  
Report Date: \_\_\_\_\_

Project Status Update:

Problems/Delays:

\_\_\_\_\_  
Signature of Authorized Official \_\_\_\_\_  
Date



Appendix IV Financial Reimbursement of Expenditures Reporting Form

Prepare an itemized request for reimbursement expenditures in each budget categories for each deliverable. Attach copies of purchase orders and paid vouchers, invoices, copies of checks, journal transfers, required for expenditure justifications. If there is insufficient space, please include details in an attachment.

County:		Grant Number:		Request Number:		Request Date:	
---------	--	---------------	--	-----------------	--	---------------	--

Budget Categories				Previous Request Amount (\$)	Current Request Amount (\$)
Deliverable Items	Unit Price (\$)	Quantity	Total Amount (\$)		
A. Systems (Hardware, Software, Equipment & Labor)					
B. Services (Training, Maintenance and Warranty Items)					
<b>Grant Request Total</b>					

<b>Request payment of funding (if applicable)</b> <input type="checkbox"/>
Justification of payment funding need:

\_\_\_\_\_  
Signature, County 911 Coordinator

## Addendum I

### Funding Priorities for the E911 Rural County Grant Program

The criteria for determining acceptability for disbursement of funds from the State of Florida E911 Rural County Grant Program will be made on a priority basis. There will be five priorities as identified below:

**PRIORITY 1:** Rural counties with E911 Phase II Primary PSAP systems that require immediate system replacement to maintain enhanced 911 status or when the expected remaining life of the system is less than 1 year.

**PRIORITY 2:** Rural counties with E911 Phase II systems that require maintenance or warranty agreements for maintaining enhanced 911 status. This may include the following, listed in order of funding priority a through c:

- a: E911 System Maintenance (pertaining exclusively to items listed in Priorities 3a-h only)
- b: Hosted E911 System Service for subsequent years, after the first year.
- c: E911 Mapping System Maintenance (pertaining exclusively to items listed in Priority 5a only)

**PRIORITY 3:** Rural counties with E911 Phase II Primary PSAP systems that require new or replacement of critical or necessary hardware or software for maintaining E911 Phase II status. This may include the following, listed in order of funding priority a through h:

- a: Hardware and software for communications or terminal equipment located at a PSAP for 911 call processing, ANI and ALI display and call answering.
- b: Lightning Protection Equipment
- c: Uninterruptible Power Supply Equipment
- d: E911 Voice Recording Equipment
- e: County E911 Standalone ALI Database Equipment
- f: E911 Map Display Equipment
- g: New additional 911 Call Taker Position Equipment
- h: Net clock

**PRIORITY 4:** Rural counties with E911 Phase II Systems requesting consolidation of E911 PSAPs, which decreases the number of Primary or Secondary PSAPs in the county by a minimum of one.

**PRIORITY 5:** Rural counties with E911 Phase II Systems that require mapping services necessary for maintaining E911 Phase II Geographic Information Systems (GIS). This may include the following, listed in order of funding priority a through b:

- a: E911 Mapping System Equipment - E911 map generation hardware and software licensing is limited to components for two stations
- b: GIS Centerline, point generation and map accuracy services

Regional E911 system project requests related to systems, equipment and maintenance will be considered the highest priority within each priority category.

Grants awards will be funded in order of priority assigned. Total funding for any priority may be adjusted based on the remaining funds available, the number of applications and the anticipated requests in the next funding cycle. The acceptability for disbursement of funds from the State of Florida E911 Rural County Grant Program for any E911 expense items not expressly provided for in Priorities above shall be determined at the discretion of the E911 Board pursuant to its authority under sections 365.172 and 365.173, Florida Statutes.

## COUNTY E911 FISCAL INFORMATION

Item No.	E911 Fee Revenues		
1	County	<input type="text" value="Columbia"/>	Fiscal Year
		<input type="text" value="2016"/>	
2	Wireless E911 Fee Revenue	<input type="text" value="\$ 117,472.50"/>	
3	Non-wireless E911 Fee Revenue	<input type="text" value="\$ 81,224.22"/>	(LEC, wireline, & VoIP)
4	Prepaid E911 Fee Revenue	<input type="text" value="\$ 49,196.89"/>	
5	E911 State Grant Revenue	<input type="text" value="\$ -"/>	(Grant required unique accounting code)
6	Rural County Grant Revenue	<input type="text" value="\$ 66,455.11"/>	(Grant required unique accounting code)
7	Emergency Grant Revenue	<input type="text" value="\$ -"/>	(Grant required unique accounting code)
8	Rural County Supplemental Disbursement	<input type="text" value="\$ -"/>	
9	E911 Board Special Disbursement	<input type="text" value="\$ 1,200.00"/>	
10	Total E911 Fee Revenue	<input style="background-color: #92d050;" type="text" value="\$ 247,893.61"/>	Carry Forward Fee Revenue calculation (Item #2 + Item #3 + Item #4)
Item No.	E911 Allowable Expenditures		
11	E911 Fee Revenue and Supplemental and Special Disbursement Expenditures	<input type="text" value="\$ 249,093.61"/>	
12	County Funded E911 Expenditures	<input type="text" value="\$ 320,879.05"/>	
13	Subtotal Expenditures	<input style="background-color: #92d050;" type="text" value="\$ 569,972.66"/>	Calculation (Item #11 + Item #12)
14	E911 State Grant Expenditures	<input type="text" value="\$ -"/>	
15	Rural County Grant Expenditures	<input type="text" value="\$ 66,455.11"/>	
16	Emergency Grant Expenditures	<input type="text" value="\$ -"/>	
17	Subtotal Grant Expenditures	<input style="background-color: #92d050;" type="text" value="\$ 66,455.11"/>	Calculation Item #14 + Item #15 + Item #16
18	Total E911 Expenditures	<input style="background-color: #92d050;" type="text" value="\$ 636,427.77"/>	Calculation Item #13 + Item #17
Item No.	E911 Carry Forward & Excess Cost Recovery Calculation		
19	Allowable County Carry Forward Amount	<input style="background-color: #92d050;" type="text" value="\$ 75,568.08"/>	Maximum allowable calculation (30% of fee revenue Item #10) + (full amount of Item #8 + Item #9 disbursements). Grants are under unique accounting codes and are not included in calculations.
20	Actual County Carry Forward Amount	<input type="text" value="\$ -"/>	<b>Limited by paragraph 365.173(2)(d), Florida Statutes. Assure amount is equal to or less than Item #19</b>
22	Excess Cost Recovery	<input style="background-color: #92d050;" type="text" value="\$ (320,879.05)"/>	Calculation (Item #10 + Item #8 + Item #9 - Item #13 - Item #20) Positive amount equals excess cost recovery amount to be returned to the E911 Board.
Item No.	Contact Information		
24	Name of person preparing response:	<input type="text" value="Danielle Beard"/>	
25	Title/Position of person preparing response:	<input type="text" value="Finance Director for Board of County Commissioners"/>	
26	Telephone number:	<input type="text" value="386-758-1152"/>	
27	E-Mail address of person preparing response:	<input type="text" value="dbeard@columbiacountyfla.com"/>	
28	Date:	<input type="text" value="12/1/2016"/>	
In accordance with paragraph 365.173(2)(d) and 365.172(6)(a)3., Florida Statutes			



Quote Number: AK020617-701

Site (name/#): Columbia County, FL - EOC

Contact: Thomas Brazil

Email: tbrazil@columbiacountyfla.com

Reference:

Date Issued: February 6, 2017

Scope of Work: Exacom Support (07/01/2017 - 06/30/2018)

Qty.	Part No.	Description	Unit Price	U/M	Total
		<b>Exacom Second Tier Support</b>			\$2,827.00
		<ul style="list-style-type: none"> <li>• Comprehensive 24/ 7 technical maintenance support program</li> <li>• Includes support, patches and upgrades to all software components.</li> <li>• Hardware Repairs</li> </ul>			
<p><i>AK Associates provides the first line of 24/7 support to the customer through the established call out procedure. Should technical support be needed from the equipment vendor, the AK technician will act as the point of contact and agent of the customer, and will establish vendor contact and work with the vendor's representative to resolution.</i></p>					
<b>Total</b>					<b>\$2,827.00</b>

Disclaimers: This quote is provided for the contact listed above and is not to be shared or disseminated without written consent by AK Associates. This quote null and voids any previous version. Quote is valid for 120 days.



Quote Number: AK020617-705

Site (name/#): Columbia County, FL Side A (EOC)

Contact: Thomas Brazil

Email: [tbrazil@columbiacountyfla.com](mailto:tbrazil@columbiacountyfla.com)

Reference: AK67340-1

Date Issued: February 2, 2016

Scope of Work: Airbus Support Side A (06/01/2017 - 05/31/2018). Airbus support includes: Comprehensive 24/7 telephone support, Software bug fixes, and Software upgrades.

**VESTA® 9-1-1**

Qty.	Part No.	Description	Unit Price	U/M	Total
1	04000-68005-RNWL	<i>VM Medium Server Bundle</i> V-SVR BASIC RNWL SPT 1YR	\$95.00	EA	\$95.00
<i>VESTA® 9-1-1 Prime Standard Operations</i>					
9	SS-0PR-VSSL-1Y	SPT VPRIME 1YR	\$990.00	EA	\$8,910.00
<i>VESTA® 9-1-1 IRR Module</i>					
9	809800-35110	V911 IRR SW SPT 1YR	\$179.00	EA	\$1,611.00
1	809800-35120	V911 ACT VIEW SW SPT 1YR	\$630.00	EA	\$630.00
2	04000-00186	SW SPT M1000 GATEWAY 1YR	\$300.00	EA	\$600.00
<b>VESTA® 9-1-1 Subtotal</b>					<b>\$11,846.00</b>

**VESTA® Analytics**

Qty.	Part No.	Description	Unit Price	U/M	Total
9	SA-MSG-ALSL-1Y	<i>VESTA® Analytics - Standard Multi Product Purchase</i> SPT V-ANLYT STD 1YR	\$117.00	EA	\$1,053.00
<b>VESTA® Analytics Subtotal</b>					<b>\$1,053.00</b>

**VESTA® Locate**

Qty.	Part No.	Description	Unit Price	U/M	Total
9	809800-11406	<i>VESTA® Locate Mapping Multi Product Purchase</i> V-LOC SPT RNW 1YR	\$630.00	EA	\$5,670.00
<b>VESTA® Locate Subtotal</b>					<b>\$5,670.00</b>

**VESTA® DataSync**

Qty.	Part No.	Description	Unit Price	U/M	Total
1	809800-01369	<i>VESTA® DataSync 4.1 (LAN)</i> ORDS HOST SPT 1YR	\$540.00	EA	\$540.00
9	809800-01364	ORDS CLIENT SPT 1YR	\$27.00	EA	\$243.00
<b>VESTA® DataSync Subtotal</b>					<b>\$783.00</b>

**VESTA® Network Management Center**

Qty.	Part No.	Description	Unit Price	U/M	Total
13	809800-16231	<i>Security Management Solution</i> SEC MGMT 3.1 SVC 1YR	\$379.00	EA	\$4,927.00
<b>VESTA® Network Management Center Subtotal</b>					<b>\$4,927.00</b>

### Quote Summary

PRODUCT	TOTAL
VESTA® 9-1-1	\$11,846.00
VESTA® Analytics	\$1,053.00
VESTA® Locate	\$5,670.00
VESTA® DataSync	\$783.00
VESTA® Network Management Center	\$4,927.00
<b>TOTAL Side A</b>	<b>\$24,279.00</b>

Disclaimers: This quote is provided for the listed contact and is not to be shared or disseminated without written consent by AK Associates. This quote null and voids any previous version. Quote is valid for 120 days.

*AK Associates provides the first line of 24/7 support to the customer through the established call out procedure. Should technical support be needed from the equipment vendor, the AK technician will act as the point of contact and agent of the customer, and will establish vendor contact and work with the vendor's representative to resolution.*



Quote Number: AK020617-705

Site (name/#): Columbia County, FL Side B (BU)

Contact: Thomas Brazil

Email: [tbrazil@columbiacountyfla.com](mailto:tbrazil@columbiacountyfla.com)

Reference: AK67340-2

Date Issued: February 6, 2017

Scope of Work: Airbus Support Side B (06/01/2017 - 05/31/2018). Airbus support includes: Comprehensive 24/7 telephone support, Software bug fixes, and Software upgrades.

**VESTA® 9-1-1**

Qty.	Part No.	Description	Unit Price	U/M	Total
1	04000-68005-RNWL	<i>VM Medium Server Bundle</i> V-SVR BASIC RNWL SPT 1YR	\$95.00	EA	\$95.00
4	SS-0PR-VSSL-1Y	<i>VESTA® 9-1-1 Licenses</i> <i>VESTA® 9-1-1 Prime Standard Operations</i> SPT VPRIME 1YR	\$990.00	EA	\$3,960.00
4	809800-35110	<i>VESTA® 9-1-1 IRR Module</i> V911 IRR SW SPT 1YR	\$179.00	EA	\$716.00
1	809800-35120	<i>VESTA® 9-1-1 Activity View</i> V911 ACT VIEW SW SPT 1YR	\$630.00	EA	\$630.00
2	04000-00186	<i>Peripherals &amp; Gateways</i> SW SPT M1000 GATEWAY 1YR	\$300.00	EA	\$600.00
<b>VESTA® 9-1-1 Subtotal</b>					<b>\$6,001.00</b>

**VESTA® Analytics**

Qty.	Part No.	Description	Unit Price	U/M	Total
4	SA-MSG-ALSL-1Y	<i>VESTA® Analytics - Standard Multi Product Purchase</i> SPT V-ANLYT STD 1YR	\$117.00	EA	\$468.00
<b>VESTA® Analytics Subtotal</b>					<b>\$468.00</b>

**VESTA® Locate**

Qty.	Part No.	Description	Unit Price	U/M	Total
4	809800-11406	<i>VESTA® Locate Mapping Multi Product Purchase</i> V-LOC SPT RNW 1YR	\$630.00	EA	\$2,520.00
<b>VESTA® Locate Subtotal</b>					<b>\$2,520.00</b>

**VESTA® DataSync**

Qty.	Part No.	Description	Unit Price	U/M	Total
4	809800-01364	<i>VESTA® DataSync 4.1 (LAN)</i> ORDS CLIENT SPT 1YR	\$27.00	EA	\$108.00
<b>VESTA® DataSync Subtotal</b>					<b>\$108.00</b>

**VESTA® Network Management Center**

Qty.	Part No.	Description	Unit Price	U/M	Total
6	809800-16231	<i>Security Management Solution</i> SEC MGMT 3.1 SVC 1YR	\$379.00	EA	\$2,274.00
<b>VESTA® Network Management Center Subtotal</b>					<b>\$2,274.00</b>



### Quote Summary

PRODUCT	TOTAL
VESTA® 9-1-1	\$6,001.00
VESTA® Analytics	\$468.00
VESTA® Locate	\$2,520.00
VESTA® DataSync	\$108.00
VESTA® Network Management Center	\$2,274.00
Side B Total	\$11,371.00
Side A Total	\$24,279.00
<b>GRAND TOTAL Side A &amp; B</b>	<b>\$35,650.00</b>

Disclaimers: This quote is provided for the listed contact and is not to be shared or disseminated without written consent by AK Associates. This quote null and voids any previous version. Quote is valid for 120 days.

*AK Associates provides the first line of 24/7 support to the customer through the established call out procedure. Should technical support be needed from the equipment vendor, the AK technician will act as the point of contact and agent of the customer, and will establish vendor contact and work with the vendor's representative to resolution.*



Quote Number: AK020617-706

Site (name/#): Columbia County, FL

Contact: Thomas Brazil

Email: [tbrazil@columbiacountyfla.com](mailto:tbrazil@columbiacountyfla.com)

Reference: 4005023575

Date Issued: February 6, 2017

Scope of Work: Fortinet Firewall Support (06/01/17 - 05/31/18)

	Description	Total
FQ619930-1	<b>Fortinet Firewall Support</b> 24x7 Comprehensive Web Support, OS updates, Advance return and replace for FortiWiFi - 60cm.	<b>\$303.95</b>
<i>AK Associates provides the first line of 24/7 support to the customer through the established call out procedure. Should technical support be needed from the equipment vendor, the AK technician will act as the point of contact and agent of the customer, and will establish vendor contact and work with the vendor's representative to resolution.</i>		
<b>Total</b>		<b>\$303.95</b>

Disclaimers: This quote is provided for the listed contact and is not to be shared or disseminated without written consent by AK Associates. This quote null and voids any previous version. Quote is valid for 120 days.

**APPLICATION**

**E911 RURAL COUNTY GRANT  
PROGRAM**

**W Form 1A, incorporated by reference in Rule 60FF1-5.002, Florida  
Administrative Code, Rural County Grants  
E911 Rural County Grant Program Application,  
Revised 02/17/16**

## 1.0 Purpose

The E911 Rural County Grant Program is to assist rural counties with the installation and maintenance of an Enhanced 911 (E911) system and to provide "seamless" E911 throughout the State of Florida.

## 2.0 Eligibility

The Board of County Commissioners in any county in the State of Florida with a population of less than 75,000 as per the most recent published data from the Florida Association of Counties' directory is eligible to apply for this grant program. Funding priorities are established in Addendum I.

## 3.0 Definitions

- A. Enhanced 911 (E911): As defined by subsection 365.172(3)(h), Florida Statutes, and as referenced in the State E911 Plan under section 365.171, Florida Statutes.
- B. E911 Maintenance: Means the preventative, routine and emergency maintenance required by the State E911 Plan, in order to maintain the E911 System in operable working condition.
- C. E911 System: Means the Public Safety Answering Point equipment, in accordance with the State E911 Plan, including 911 call routing, processing, mapping and call answering communications equipment.
- D. Next Generation 911 (NG-911): Means the designation for an advanced 911 emergency communications system or service that provides a communications service subscriber with 911 service and, in addition, directs 911 emergency requests for assistance to appropriate public safety answering points based on the geographical location from which the request originated, or as otherwise provided in the State E911 Plan under Section 365.171, Florida Statutes, and that provides for automatic number identification and automatic location identification features and emergency data information through managed IP-based networks.
- E. Public Safety Answering Point (PSAP): As defined by paragraph 365.172(3)(y), Florida Statutes, and as referenced in the State E911 Plan under section 365.171, Florida Statutes.

## 4.0 E911 Rural County Grant Program Calendar

	Spring Schedule	Fall Schedule
Counties submit Application	by April 1	by October 1
E911 Board Members evaluate applications	April – May	October – November
E911 Board votes on applications to fund at regularly scheduled meeting	April – June	October – December
E911 Board sends notification of awards approved for funding to the counties.	before June 30	before December 30
Implementation period	One year from the award notification letter date.	One year from the award notification letter date.
Expiration of the right to incur costs, request payment and/or final reimbursement of funding.	Two years from the award notification letter date	Two years from award notification letter date.

## **5.0 General Conditions**

### **5.1 Applications must be delivered to the following address:**

State of Florida E911 Board  
ATTN: E911 Board Administrative Staff  
4030 Esplanade Way, Suite 135  
Tallahassee, FL 32399-0950  
Or [E911BoardElectronicGrantReports@dms.myflorida.com](mailto:E911BoardElectronicGrantReports@dms.myflorida.com)

- 5.2** The applicant must provide one original of the pages for Application Form items 1 through 14 the associated quotes, and the E911 Board Form 6A, "County E911 Fiscal Information," included in E911 Board Rule 60FF1-5.006, Florida Administrative Code. The grant application package must be postmarked or delivered on or before April 1 or October 1 of each year, dependent on the spring or fall application period. Failure to provide these documents will result in automatic rejection of the grant application. One scanned copy of the entire submitted package should also be provided on a CD-ROM, to ensure quality of the documents to be reviewed.
- 5.3** The E911 Board will consider remotely provided hosted 911 answering point call-taking equipment and network services directly attributable to establishing and provisioning E911 or NG-911 services. Warranty and maintenance costs shall be calculated to account for only the first year warranty and maintenance costs and shall not include upfront maintenance costs to reduce the yearly service amount.
- 5.4** All grant applications shall be accompanied by at least one complete quote for equipment or services. Grant applications totaling \$35,000.00 or more must be accompanied by at least three written substantiated competitive complete quotes from different vendors. Complete quote submittals shall include a detailed scope of work, all pages included in the vendor proposal, breakdown of all costs including equipment, service tasks and deliverables. The E911 Board will compare the three quotes to any existing state contract in order to determine appropriate funding. Any county that has made a good faith effort to obtain at least three competitive quotes and has not been able to obtain the quotes can request E911 Board review based on substantiated proof of request for quotes or posting of the request with documentation of the limited responses.
- 5.5** If the grant application does not exceed the threshold amount of \$195,000, the county can initiate a request for approval for sole source funding. These will be considered on a case-by-case basis. Justification for sole source funding shall be provided with the application. Sole source will be approved if provided in accordance with Chapter 287, Florida Statutes, or with provision of a letter from the county's purchasing department that the project is a sole source procurement based on the county's purchasing requirements, which shall be provided with this grant application. Include pricing justification in the sole source letter from the county's purchasing department.
- 5.6** Rather than submitting multiple application requests for maintenance, all eligible maintenance requests should be combined into a single application request and include a breakdown of the individual components of the E911 system maintenance costs that are requested for funding assistance in the application. Grant applications for maintenance, where the county obtained a grant or utilized county funds to purchase equipment and obtained three competitive quotes for the first year of maintenance, or met the requirements of General Conditions items 5.4 or 5.5, are not required to provide three written quotes with an application for an additional year of maintenance.

- 5.7 All maintenance requests should include on the vendor's quote for service the beginning and ending term for each maintenance request. Grant awards will be limited to maintenance contracts beginning prior to or within the maintenance cycle of the grant program. Spring cycle maintenance requests should be submitted for maintenance beginning May through October. Fall cycle maintenance requests should be submitted for maintenance beginning November through April. Complete quote shall include a detailed scope of work, all pages included in the vendor proposal, breakdown of all costs including equipment, service tasks and deliverables.
- 5.8 Applicants requesting items from different funding priorities should complete a separate application for each priority. See Addendum I - Funding Priorities for the E911 Rural County Grant Program for a listing of funding priorities. Items from the same funding priorities should be combined in the same application and shall comply with General Condition items 5.4 and 5.5.
- 5.9 Should two or more rural counties jointly apply for a grant, each county will be required to complete and submit a grant application detailing the funds requested and the county responsible for the funds. In addition one combined grant application detailing the entire project and a memorandum of understanding or inter-local agreement of all counties involved shall be submitted. The combined grant application shall comply with General Condition items 5.4 and 5.5.
- 5.10 Procurement shall be based on the county's purchasing requirements and the applicable State purchasing requirements, including Section 112.061, Florida Statutes. All travel and associated per diem costs proposed shall be in compliance with General Conditions item 6.3.5.
- 5.11 Funding application requests must include a scope of work that clearly establishes the tasks to be performed. The applications shall include all tasks that are required for successful completion of the project. The project shall be divided into quantifiable units of deliverables that shall be received and accepted in writing by the county before payment. Each deliverable must be directly related to the scope of work and must specify the required minimum level of service to be performed and the criteria for evaluating the successful completion of each deliverable.
- 5.12 Funding requests must include all necessary costs required for full implementation of the proposed solution including that of any third party. Should the county grant application request or grant award be less than the projected cost of the equipment or service, the county should provide verification of the ability to fund the difference. Pricing submitted cannot be contingent upon "yet to be" determined fees for products and services by the proposer or any other third party required for implementation.
- 5.13 The county shall provide information on the county's preceding year E911 fee revenue amount, the preceding year carry forward funding amount and the total carry forward balance amount in the county E911 fund. The amount of grant funding award, for allowable carry forward expenditures, is limited based on the total amount of carry forward funding in the county E911 fund in excess of an amount calculated based on the allowable 30 percent carry forward amount for a two year basis in accordance with sub-paragraph 365.172(6)(a)3.c., Florida Statutes and E911 Board Rule 60FF1-5.006 Florida Administrative Code. The county shall include the amount of their county carry forward funding being utilized for this grant in the Applied County Carry Forward or other Funding (if applicable) line in the Application Form item #12. Budget/Expenditure Report. This carry forward funding provision does not apply to grant applications for recurring maintenance. Maintenance contract cost is not a capital expenditure and is not an authorized expenditure of carry forward funds after the initial first year project costs included in the original capital equipment replacement or upgrade project.

5.14 Detailed information is required for any grant application requesting funding for systems that require immediate system replacement for provisioning of enhanced 911 in the county. Include detailed justification and explanation for any E911 system with an expected remaining life of less than 1 year.

5.15 Funding requests contingent upon "beta testing" or for products and services not in general production and installation will not be funded.

## **6.0 Limitation on Use of Funds**

6.1 Only eligible expenses for E911 service listed in subsection 365.172(10), Florida Statutes, (Appendix I) that are not specifically excluded in this application will be funded.

6.2 Specifically excluded E911 expenses:

6.2.1 Salaries and associated expenses for 911 coordinators and call takers or other 911 personnel will not be funded.

6.2.2 Wireline database costs from the local exchange carrier, vehicle expenses, outside plant fiber or copper cabling systems and building entrance build out costs, consoles, workstation furniture and aerial photography expenses will not be funded.

6.2.3 Wireline 911 analog trunks, administrative lines and circuits are not fundable. Recurring network and circuit costs will not be funded after the first year implementation period.

6.3 Funding limitations are specified on the following items:

6.3.1 Grant funding shall be limited to eligible equipment maintenance and warranty costs for a primary PSAP and one other PSAP per county; either a primary, a secondary or a backup.

6.3.2 Grant funding shall be limited to eligible mapping maintenance and warranty costs for a primary PSAP and one other PSAP per county; either a primary, a secondary or a backup.

6.3.3 Grant funding for 911 equipment, hardware and software shall be limited (per grant cycle) to eligible expenditures for a primary PSAP only.

6.3.4 Selective router equipment costs are limited to the primary PSAP system and are limited to one per county. For this grant program they are included under the call handling equipment priority.

6.3.4 Training cost funding is limited to new system & equipment training.

6.3.5 The allowable grant funding for travel expenses is limited to the authorized amounts established in Section 112.061, Florida Statutes, and the Department of Financial Services Guidelines for State Expenditures. Allowable costs for daily per diem shall not exceed \$186.00.

## **7.0 Approval and Award**

7.1 The E911 Board will review each application for compliance with the requirements of terms and conditions.

- 7.2 Grant awards will be withheld for any county that has a grant with a past-due quarterly report or past-due final documentation and closeout of previous rural county grant awards.
- 7.3 Applications will be awarded based upon the priorities set by the E911 Board as listed in Addendum I - Funding Priorities for the E911 Rural County Grant Program.
- 7.4 The E911 Board will adjust the amount awarded to a county based upon the availability of funds, eligibility of requested items, published quotes, increased effectiveness of grant funds, minimum system requirements for performing the needed E911 function as specified in the State E911 Plan, or documented factors provided in the grant application submission.
- 7.5 Any county that requires Board of County Commissioner approval of the grant program funding, prior to commencement of the project, shall notify the E911 Board in Application Form item #10. Grant funds for approved grant applications will be held until the county provides written notification to the E911 Board of the Board of County Commissioners approval of the project prior to the funds being disbursed from the E911 Trust Fund.
- 7.6 Any conditional hold, for documentation submittal referenced in 7.2 and 7.5, is limited to the last regularly scheduled E911 Board meeting application vote established in the grant program calendar.

**8.0 Financial and Administrative Requirements**

- 8.1 Grant funds shall be provided on a cost reimbursement basis. Grant funds shall be deposited in an interest bearing account maintained by the grantee, and each grant shall be tracked using a unique accounting code designator for deposits, disbursements and expenditures assigned by the county. All grant funds in the account maintained by the grantee shall be accounted for separately from all other funds. Any interest generated shall be returned to the E911 Board.
- 8.2 Each grantee may submit reimbursement claims to the E911 Board as needed; however claims are limited to one request per month. Receipt of reimbursement funds from the E911 Board is contingent on the timely and accurate submittal of funding requests. Requests for reimbursement of expenditures must be submitted on the approved Appendix IV Financial Reimbursement of Expenditures Reporting Form. Incomplete claims forms or claims not submitted on the correct form cannot be processed and will be returned for corrections. Submit only for the amounts in each budget categories in which you have incurred expenditures.
- 8.3 Upon written request and accompanying documentation justifying the need, a county may receive a payment of funding with a completed Expenditures Reporting Form, with the vendor invoice, and county certification that the specific grant items including all tasks and deliverables included in the funding request are complete. Within 45 days of transfer of funding or the check date, the grantee shall submit verification of payment to the vendor.
- 8.4 Reimbursement claims shall include only expenditures claimed against the specific grant number awarded and include copies of purchase orders and paid vouchers, invoices, copies of check processing, journal transfers. To assure prompt processing, complete reimbursement claims should be e-mailed to:

[E911Board-ElectronicGrantReports@dms.myflorida.com](mailto:E911Board-ElectronicGrantReports@dms.myflorida.com)



- 8.5 Grant funds, can only be used between the beginning and ending dates of the grant term, unless the E911 Board authorizes an extension. The right to incur costs under this grant expires two years from receipt of award and funds. The grantee may not incur costs and request payment or final reimbursement of funding past the expiration date.
- 8.6 Responsibility for grant funding and any failure to perform the minimum level of service required by the grant application and the application scope of work cannot be transferred under any circumstances from the County. Failure to perform the scope of work or expenditure of funds for other than allowable 911 costs as stated in the grant application shall require the county to return the awarded funds to the E911 Board.
- 8.7 Responsibility for property and equipment obtained under a grant cannot be transferred under any circumstances. If a sale or transfer of such property or equipment occurs within five years after a grant ends, funds must be returned to the E911 Board on a pro rata basis.
- 8.8 The grantee agrees that any improvement, expansion or other effect brought about in whole or part by grant funds will be maintained for a minimum of five years or thereafter until the effective replacement date of the system.
- 8.9 If a grantee materially fails to comply with any term of an award, the Board shall take one or more of the following actions, as appropriate in the circumstances:

- Temporarily withhold grant payments pending grantee correction of the deficiency,
- Disapprove all or part of the cost of the activity or action not in compliance,
- Suspend or terminate the current award for the grantee's project,
- Suspend or deny future grant awards.

The Board will provide the grantee an opportunity for a hearing, appeal, or other administrative proceeding to which the grantee is entitled under Florida Statute or regulation applicable to the action involved.

- 8.10 Grant awards may be terminated in whole or in part by the Board, with the consent of the grantee, in which case the two parties shall agree upon the termination conditions, including the effective date and in the case of partial termination, the portion to be terminated. Grant awards may be terminated by the grantee upon written notification to the Board, detailing the reasons for such termination, the effective date, and return of all funding.
- 8.11 Grant funds provided in excess of the amount to which the actual cost incurred to meet the terms and conditions of the grant agreement must be refunded to the E911 Board and sent to the Florida E911 Board's Post Office Box address:  
 Florida E911 Board  
 PO Box 7117  
 Tallahassee, FL 32314  
 The refund shall include transmittal information detailing the amount of returned funds that are excess grant funding and/or returned interest and shall include the number of the associated grant.

**9.0 Grant Reporting Procedures**

- 9.1 Grantees will be required to submit quarterly reports summarizing cumulative expenditures and status of the grant project. Quarterly reports shall include an updated Application Form item #12 Budget/Expenditure Report and a completed Appendix III Quarterly Report Form.
- 9.1.1 Reporting will begin at the conclusion of the first full quarter after the award. The report periods will end on March 31, June 30, September 30, and December 31 of each year. Reports are due within 30 days of the ending report period.
- 9.1.2 Earned interest shall be reported cumulatively and included with each quarterly report.
- 9.1.3 Updated reports and associated information should be e-mailed to [E911Board-ElectronicGrantReports@dms.myflorida.com](mailto:E911Board-ElectronicGrantReports@dms.myflorida.com).
- 9.2 At project completion, a final report shall be submitted based on the same reporting requirements described in grant reporting item 9.1. The county shall determine the final completion date based on the final payment date, or the initiation date of the warranty period. Final documentation including copies of all expenditures and corresponding invoices shall be submitted within 90 days of the final report.
- 9.3 Change requests shall be submitted prior to deviation from any awarded grant applications. No changes or departures from the original request are authorized unless approved in writing by the E911 Board. Such requests shall be submitted using the form attached in Appendix II, Request for Change Form. Any unauthorized change shall require the return of grant funds, plus any interest accrued.
- 9.3.1 Time extension requests will not be granted unless the county has executed a contract for the grant equipment and/or services, or demonstrates good cause for failure to execute a contract within twelve months of award. Good cause documentation shall include a new project timeline schedule.
- 9.3.2 Time extensions shall be limited to a maximum of one additional year when approved by the E911 Board.
- 9.3.3 Request for Change forms and associated information should be e-mailed to [E911Board-ElectronicGrantReports@dms.myflorida.com](mailto:E911Board-ElectronicGrantReports@dms.myflorida.com).
- 9.4 The Appendix III Quarterly Report Form shall inform the E911 Board of significant impacts to grant supported activities. Significant impacts include project status developments affecting time schedules and objectives, anticipated lower costs or producing beneficial results in addition to those originally planned. Additionally, problems, delays, or adverse conditions which will materially impair the ability to meet the timely completion of the award must be reported. The disclosure must include a statement of the action taken, or contemplated, and any assistance needed to resolve the situation.
- 9.5 The county's Board of County Commission chairperson shall be notified when overdue quarterly reports or final reports are not received before the next E911 Board meeting following the month after the end of the quarter in which they are due.
- 9.6 Funding continuance will be based on timely submission of quarterly reports.

- 9.7 Final document submission and close-out of a grant does not affect the E911 Board's right to disallow costs and recover funds on the basis of an audit or financial review. The county shall remain obligated to return any funds expended that do not comply with the terms and conditions of the grant award.

County COLUMBIA

**STATE OF FLORIDA E911 BOARD  
E911 RURAL COUNTY GRANT PROGRAM APPLICATION FORM**

Total Amount Requested: \$67,210.00

Project Title: MAINTENANCE & SUPPORT

1. Board of County Commissioners Chair: Ronald Williams

Mailing Address: 135 N.E. Hernando Ave  
Mailing: P.O. Box 1529  
City: Lake City  
State: Florida Zip: 32056 - 1529  
Phone: ( 386 ) 758-1005 Fax (386) 758-2128  
Email Address: Penny\_stanley@columbiacountyfla.com

2. County 911 Coordinator: Thomas W. Brazil

Mailing Address: Columbia County Combined Communications Center 911  
263 N.W. Lake City Av.  
City: Lake City  
State: Florida Zip: 32055 - 1529  
Phone: (386) 758- 1388 Fax: 386 758-1386  
Email Address: tbrazil@columbiacountyfla.com

3. Federal Tax ID Number: 59-6000564

County COLUMBIA

**COUNTY INFORMATION**  
**USE 12 POINT FONT OR LEGIBLE HAND PRINTING**

4. County Fact Information

A. County COLUMBIA

B. Population 67,966

C. Total Number of Incoming Nonwireless Trunks 8

D. Total Number of Incoming Wireless Trunks 8

E. Number of PSAP's 1

F. Number of Call-taking Positions per PSAP Primary 9 Auxiliary (Side B) 4 for total of 13

G. Total Volume of 911 Calls \_\_\_\_\_

H. What equipment is needed to maintain the Enhanced 911 system?

Maintenance & Support

I. What equipment is requested in this grant application?

Maintenance & Support

J. Financial Information:

1.) What are the current annual costs for your E911 system (circuits, customer records hardware and software, etc.) not including maintenance?

\$570,826.75

2.) What are the current annual costs for maintenance of items included in 1.)?

\$67,210.00

3.) Total amount of E911 fee revenue received in the preceding year?

\$249,093.61

4.) Total amount of county carry forward funding retained in the preceding year?

\$0.0

5.) Current total amount of county carry forward funding?

\$0.0

6.) Two year maximum calculated amount for applied carry forward funding

Calculation (current year carry forward

\$0.0

funding amount based on General

Condition 5.13 multiplied by two)

7.) Minimum calculated amount for Applied Carry Forward Funding

Calculation (amount in J.5. subtracted by

\$0.0

amount in J.6.)

Insert in Item 12. Budget Expenditure Report \_\_\_\_\_

5. Describe your county's existing E911 system. Include specific information on existing system equipment upgrades and when the installation of this equipment was completed.

*Columbia County operates a Type 4 Enhanced 911 System with state of the art geo-diverse, Airbus DS Communications VESTA 911 equipment which was installed May 31, 2015. It includes a nine (9) position primary PSAP center and, as the County Center is the only PSAP in Columbia County, a four (4) position side B Auxiliary PSAP designed and engineered to provide redundancy and minimize the chances of a total 911 system outage. The County also utilizes two (2) Exacom G2 Time Gate logging recorders, installed in July 2012 and 2013 respectively. AT&T provides the 911 circuits, ANI/ALI data, MSAG, and selective routing services.*

6. Describe the scope of work for the proposed project including any goal(s) and objectives. Include the tasks to be performed as part of the project. Provide scope of work in quantifiable units of deliverables that shall be received and accepted. For each deliverable specify the required minimum level of service to be performed and the criteria for evaluating the successful completion of each deliverable.

*Columbia County's E-911 system is maintained under contract with AK Associates and this grant is seeking funds to renew that contract to include:*

*Exacom 911 logging recorder support (7/1/2017 - 6/30/2018) is needed to maintain the 911 logging recorders. Includes comprehensive 24/7 technical maintenance support program including support, patches and upgrades to all software components as well as hardware repairs.*

*Airbus DS Communications VESTA 911 VN server bundle as well as Orion DataSync host support and Orion DataSync client support are need to maintain & support the VESTA 911 call taking equipment. Airbus VESTA support V-server, VESTA SPT prime, VESTA 911 Modules maintenance & support, VESTA peripherals & gateways maintenance & support. VESTA Analytics maintenance & support, VESTA Locate maintenance & support and Orion DataSync VESTA managed services & support. Fortinet Firewall maintenance, support & updates for the period of 6/1/2017 through 5/31/2018. All are needed to maintain the 911 call taking equipment.*

*The goal of this grant project is to renew and continue the maintenance and support of the above listed Airbus DS Communications products to set to expire May 31, 2017 as well as renew support agreement for Exacom to insure the continued functionality of the E-911 system in Columbia County.*

The scope of work includes Airbus DS Communications VESTA software, managed services, Fortinet firewall support, and help desk support of the 911 CPE as well as (Exacom) software and hardware support for the logging recorders. The goal of this grant project is to renew the maintenance and support agreements to insure the continued functionality of the E911 system in Columbia County. AK Associates provides first tier routine and emergency maintenance for the E911 system and logging recorder.

Should technical support be needed from equipment manufacturer, the AK technician will act as the point of contact and agent for Columbia County.

The project is as follows:

- Software patches, fixes, upgrades and Tier II maintenance support on Airbus equipment.
- Software patches, hardware support, fixes, upgrades and Tier II maintenance support on Exacom equipment.

The maintenance support will be monitored and reviewed monthly with the vendor to assure the level of service is provided and the system is being maintained in operable working conditions.

**Note: for further description see scope of work and contract decryption in attachments from AK Associates**

7. Justification of the need for the proposed project. Provide detailed information on the existing system's condition including a detailed justification for any system with an expected remaining life of less than 1 year.

Without the Airbus DS Communications and Exacom logging recorder support, Columbia County would not be able to effectively maintain the County's E-911 system.

8. Describe why your county will not be able to complete this project without this grant funding.

In section 4.4 of the State E-911 Plan, coordinators are required to develop and maintain plans to limit the impact of system failures and expedite restoration of E-911 services. Our comprehensive equipment maintenance agreement currently in place with AK Associates addresses this requirement. It is our goal to continue to provide reliable, uninterrupted 911 services. The grant funding will provide the equipment maintenance and emergency repair resources necessary to ensure operation of our E-911 system.

9. Briefly describe how this grant project would be in concurrence with the State E911 Plan.

*Columbia County currently contracts with AK Associates for E-911 system service and maintenance. We need these funds to renew the Airbus DS Communications VESTA equipment & Fortinet Firewall for period of 6/1/2017 through 5/31/2018.*

*In addition we will renew Exacom Recorder Second Tier Support for 7/1/2017 through 06/30/2018.*

*Receipt of these funds will allow continuance of our current maintenance contracts without interruption or lapse in maintenance coverage.*

10. Describe the required steps with an anticipated time schedule with procurement and payment milestones and a total project completion date.

*Columbia County will renew the Airbus DS Communications VESTA equipment for the period of 6/1/2017 through 5/31/2018. In addition we will renew Exacom Recorder Second Tier Support for period 7/1/2017 through 6/30/2018.*

11. Sole source justification (if applicable).

*This will be a sole source procurement in compliance with Columbia County's purchasing policies avoid voiding any existing maintenance and warranty agreements.*



12. Budget/Expenditure Report

Prepare an itemized Grant Budget ("Line Item" breakdown should include separated systems, i.e.: 911 system, logging recorder, centerline mapping, etc. and services items). The completed form shall be used to complete quarterly report requirements, listing expenditures and revisions (if any) in appropriate columns. If there is insufficient space, please include details in an attachment. **Budget costs should match requested vendor quote.**

County: COLUMBIA Grant Number: \_\_\_\_\_ Report Date: \_\_\_\_\_

For Grant Period Ending:  March 31  June 30  September 30  December 31 Year: \_\_\_\_\_  FINAL

Proposed Budget	Line Item	Unit Price (\$)	Quantity	Total Cost (\$)	USE FOR QUARTERLY REPORTS	
					Revised Budget	Total Cumulative Expenditures (\$)
A. Systems (Hardware, Software, Equipment & Labor)						
Total System Items						
B. Services (Training, Maintenance and Warranty Items)						
Fortinet Firewall Support		\$303.95	1	\$303.95		
Airbus Vista 911 Support Side A 6/1/17-5/31/18		\$24,279.00	1	\$24,279.00		
Airbus Vista 911 Support Side B 6/1/17-5/31/18		\$11,371.00	1	\$11,371.00		
AK Associates Elite Premier Maintenance 6/1/17-5/31/18		\$28,430.00	1	\$28,430.00		
Exacon Second Tier Support 7/1/17-6/30/18		\$2,827.00	1	\$2,827.00		
Total Service Items				\$67,210.00		
Less any Applied County Carry Forward or other Funding (if applicable)				0.00		
Grant Request Total				\$67,210.00		

USE FOR ALL REPORTS	
Total Amount of Grant Awarded	
Total Interest for Grant Period	
Final Completion Date	



Signature, County 911 Coordinator

County COLUMBIA

13. Assurances

ACCEPTANCE OF TERMS AND CONDITIONS: The grantee accepts all grant terms and conditions. Grantee understands that grants are contingent upon the availability of funds.

DISCLAIMER: The grantee certifies that the facts and information contained in this application and any attached documents are true and correct. A violation of this requirement may result in revocation of the grant and return of all grant funds and interest accrued (if any), pursuant to the E911 Board authority and any other remedy provided by law.

NOTIFICATION OF AWARDS: The grantee understands and accepts that the notice of award will be advertised on the Florida E911 website.

MAINTENANCE OF IMPROVEMENT AND EXPANSION: The grantee agrees that any improvement, expansion or other effect brought about in whole or part by grant funds will be maintained. No substantial changes or departures from the original proposal shall be permitted unless the E911 Board gives prior written authorization. Any unauthorized change will necessitate the return of grant funds, and accrued interest (if any) to the E911 Board.

Failure to utilize grant funds as represented may jeopardize eligibility to be considered for future funding.

14. Authority

I hereby affirm my authority and responsibility for the use of funds requested.

\_\_\_\_\_  
SIGNATURE – CHAIR, BOARD OF COUNTY COMMISSIONERS

\_\_\_\_\_  
DATE

RON WILLIAMS CHAIRMAN  
Printed Name

\_\_\_\_\_  
WITNESS

\_\_\_\_\_  
DATE

## Appendix I

**NO requests for funding will be acknowledged for any items not specified in subsection 365.172 (10), Florida Statutes (shown below).**

### AUTHORIZED EXPENDITURES OF E911 FEE.—

(a) For purposes of this section, E911 service includes the functions of database management, call taking, location verification, and call transfer. Department of Health certification and recertification and training costs for 911 public safety telecommunications, including dispatching, are functions of 911 services.

(b) All costs directly attributable to the establishment or provision of E911 service and contracting for E911 services are eligible for expenditure of moneys derived from imposition of the fee authorized by subsections (8) and (9). These costs include the acquisition, implementation, and maintenance of Public Safety Answering Point (PSAP) equipment and E911 service features, as defined in the providers' published schedules or the acquisition, installation, and maintenance of other E911 equipment, including circuits; call answering equipment; call transfer equipment; ANI or ALI controllers; ANI or ALI displays; station instruments; E911 telecommunications systems; visual call information and storage devices; recording equipment; telephone devices and other equipment for the hearing impaired used in the E911 system; PSAP backup power systems; consoles; automatic call distributors, and interfaces, including hardware and software, for computer-aided dispatch (CAD) systems; integrated CAD systems for that portion of the systems used for E911 call taking; GIS system and software equipment and information displays; network clocks; salary and associated expenses for E911 call takers for that portion of their time spent taking and transferring E911 calls, salary, and associated expenses for a county to employ a full-time equivalent E911 coordinator position and a full-time equivalent mapping or geographical data position, and technical system maintenance, database, and administration personnel for the portion of their time spent administrating the E911 system; emergency medical, fire, and law enforcement prearrival instruction software; charts and training costs; training costs for PSAP call takers, supervisors, and managers in the proper methods and techniques used in taking and transferring E911 calls, costs to train and educate PSAP employees regarding E911 service or E911 equipment, including fees collected by the Department of Health for the certification and recertification of 911 public safety telecommunicators as required under s. 401.465; and expenses required to develop and maintain all information, including ALI and ANI databases and other information source repositories, necessary to properly inform call takers as to location address, type of emergency, and other information directly relevant to the E911 call-taking and transferring function. Moneys derived from the fee may also be used for next-generation E911 network services, next-generation E911 database services, next-generation E911 equipment, and wireless E911 routing systems.

(c) The moneys may not be used to pay for any item not listed in this subsection, including, but not limited to, any capital or operational costs for emergency responses which occur after the call transfer to the responding public safety entity and the costs for constructing, leasing, maintaining, or renovating buildings, except for those building modifications necessary to maintain the security and environmental integrity of the PSAP and E911 equipment rooms.



**Appendix III**

**Quarterly Report**

County: \_\_\_\_\_

Grant Number: \_\_\_\_\_

Report Date: \_\_\_\_\_

**Project Status Update:**

**Problems/Delays:**

\_\_\_\_\_  
Signature of Authorized Official

\_\_\_\_\_  
Date

Appendix IV Financial Reimbursement of Expenditures Reporting Form

Prepare an itemized request for reimbursement expenditures in each budget categories for each deliverable. Attach copies of purchase orders and paid vouchers, invoices, copies of checks, journal transfers, required for expenditure justifications. If there is insufficient space, please include details in an attachment.

County:	Grant Number:	Request Number:	Request Date:
---------	---------------	-----------------	---------------

Budget Categories	Unit Price (\$)	Quantity	Total Amount (\$)	Previous Request Amount (\$)	Current Request Amount (\$)
Deliverable Items  A. Systems (Hardware, Software, Equipment & Labor)					
B. Services (Training, Maintenance and Warranty Items)					
<b>Grant Request Total</b>					

**Request payment of funding (if applicable)**

Justification of payment funding need:

\_\_\_\_\_  
Signature, County 911 Coordinator

## Addendum I

### Funding Priorities for the E911 Rural County Grant Program

The criteria for determining acceptability for disbursement of funds from the State of Florida E911 Rural County Grant Program will be made on a priority basis. There will be five priorities as identified below:

**PRIORITY 1:** Rural counties with E911 Phase II Primary PSAP systems that require immediate system replacement to maintain enhanced 911 status or when the expected remaining life of the system is less than 1 year.

**PRIORITY 2:** Rural counties with E911 Phase II systems that require maintenance or warranty agreements for maintaining enhanced 911 status. This may include the following, listed in order of funding priority a through c:

- a: E911 System Maintenance (pertaining exclusively to items listed in Priorities 3a-h only)
- b: Hosted E911 System Service for subsequent years, after the first year.
- c: E911 Mapping System Maintenance (pertaining exclusively to items listed in Priority 5a only)

**PRIORITY 3:** Rural counties with E911 Phase II Primary PSAP systems that require new or replacement of critical or necessary hardware or software for maintaining E911 Phase II status. This may include the following, listed in order of funding priority a through h:

- a: Hardware and software for communications or terminal equipment located at a PSAP for 911 call processing, ANI and ALI display and call answering.
- b: Lightning Protection Equipment
- c: Uninterruptible Power Supply Equipment
- d: E911 Voice Recording Equipment
- e: County E911 Standalone ALI Database Equipment
- f: E911 Map Display Equipment
- g: New additional 911 Call Taker Position Equipment
- h: Net clock

**PRIORITY 4:** Rural counties with E911 Phase II Systems requesting consolidation of E911 PSAPs, which decreases the number of Primary or Secondary PSAPs in the county by a minimum of one.

**PRIORITY 5:** Rural counties with E911 Phase II Systems that require mapping services necessary for maintaining E911 Phase II Geographic Information Systems (GIS). This may include the following, listed in order of funding priority a through b:

- a: E911 Mapping System Equipment - E911 map generation hardware and software licensing is limited to components for two stations
- b: GIS Centerline, point generation and map accuracy services

Regional E911 system project requests related to systems, equipment and maintenance will be considered the highest priority within each priority category.

Grants awards will be funded in order of priority assigned. Total funding for any priority may be adjusted based on the remaining funds available, the number of applications and the anticipated requests in the next funding cycle. The acceptability for disbursement of funds from the State of Florida E911 Rural County Grant Program for any E911 expense items not expressly provided for in Priorities above shall be determined at the discretion of the E911 Board pursuant to its authority under sections 365.172 and 365.173, Florida Statutes.



## COUNTY E911 FISCAL INFORMATIO

Item No.	E911 Fee Revenues		
1	County	Columbia	Fiscal Year
		2016	
2	Wireless E911 Fee Revenue	\$ 117,472.50	
3	Non-wireless E911 Fee Revenue	\$ 81,224.22	(LEC, wireline, & VoIP)
4	Prepaid E911 Fee Revenue	\$ 49,196.89	
5	E911 State Grant Revenue	\$ -	(Grant required unique accounting code)
6	Rural County Grant Revenue	\$ 66,455.11	(Grant required unique accounting code)
7	Emergency Grant Revenue	\$ -	(Grant required unique accounting code)
8	Rural County Supplemental Disbursement	\$ -	
9	E911 Board Special Disbursement	\$ 1,200.00	
10	Total E911 Fee Revenue	\$ 247,893.61	Carry Forward Fee Revenue calculation (Item #2 + Item #3 + Item #4)
Item No.	E911 Allowable Expenditures		
11	E911 Fee Revenue and Supplemental and Special Disbursement Expenditures	\$ 249,093.61	
12	County Funded E911 Expenditures	\$ 320,879.05	
13	Subtotal Expenditures	\$ 569,972.66	Calculation (Item #11 + Item #12)
14	E911 State Grant Expenditures	\$ -	
15	Rural County Grant Expenditures	\$ 66,455.11	
16	Emergency Grant Expenditures	\$ -	
17	Subtotal Grant Expenditures	\$ 66,455.11	Calculation Item #14 + Item #15 + Item #16
18	Total E911 Expenditures	\$ 636,427.77	Calculation Item #13 + Item #17
Item No.	E911 Carry Forward & Excess Cost Recovery Calculation		
19	Allowable County Carry Forward Amount	\$ 75,568.08	Maximum allowable calculation (30% of fee revenue Item #10) + (full amount of Item #8 + Item #9 disbursements). Grants are under unique accounting codes and are not included in calculations.
20	Actual County Carry Forward Amount	\$ -	Limited by paragraph 365.173(2)(d), Florida Statutes. Assure amount is equal to or less than Item #19
22	Excess Cost Recovery	\$ (320,879.05)	Calculation (Item #10 + Item #8 + Item #9 - Item #13 - Item #20) Positive amount equals excess cost recovery amount to be returned to the E911 Board.
Item No.	Contact Information		
24	Name of person preparing response:	Danielle Beard	
25	Title/Position of person preparing response:	Finance Director for Board of County Commissioners	
26	Telephone number:	386-758-1152	
27	E-Mail address of person preparing response:	dbeard@columbiacountyfla.com	
28	Date:	12/31/2016	
In accordance with paragraph 365.173(2)(d) and 365.172(6)(a)3., Florida Statutes			



Quote Number: AK020617-701

Site (name/#): Columbia County, FL - EOC

Contact: Thomas Brazil

Email: tbrazil@columbiacountyfla.com

Reference:

Date Issued: February 6, 2017

Scope of Work: Exacom Support (07/01/2017 - 06/30/2018)

Qty.	Part No.	Description	Unit Price	U/M	Total
		Exacom Second Tier Support			\$2,827.00
		<ul style="list-style-type: none"> <li>• Comprehensive 24/7 technical maintenance support program</li> <li>• Includes support, patches and upgrades to all software components.</li> <li>• Hardware Repairs</li> </ul>			
<i>AK Associates provides the first line of 24/7 support to the customer through the established call out procedure. Should technical support be needed from the equipment vendor, the AK technician will act as the point of contact and agent of the customer, and will establish vendor contact and work with the vendor's representative to resolution.</i>					
<b>Total</b>					<b>\$2,827.00</b>

Disclaimers: This quote is provided for the contact listed above and is not to be shared or disseminated without written consent by AK Associates. This quote null and voids any previous version. Quote is valid for 120 days.



Quote Number: AK020617-706

Site (name/#): Columbia County, FL

Contact: Thomas Brazil

Email: [tbrazil@columbiacountyfla.com](mailto:tbrazil@columbiacountyfla.com)

Reference: 4005023575

Date Issued: February 6, 2017

Scope of Work: Fortinet Firewall Support (06/01/17 - 05/31/18)

	Description	Total
FQ619930-1	<b>Fortinet Firewall Support</b> 24x7 Comprehensive Web Support, OS updates, Advance return and replace for FortiWiFi - 60cm.	<b>\$303.95</b>
<i>AK Associates provides the first line of 24/7 support to the customer through the established call out procedure. Should technical support be needed from the equipment vendor, the AK technician will act as the point of contact and agent of the customer, and will establish vendor contact and work with the vendor's representative to resolution.</i>		
<b>Total</b>		<b>\$303.95</b>

Disclaimers: This quote is provided for the listed contact and is not to be shared or disseminated without written consent by AK Associates. This quote null and voids any previous version. Quote is valid for 120 days.



Quote Number: AK020617-705

Site (name/#): Columbia County, FL Side A (EOC)

Contact: Thomas Brazil

Email: [tbrazil@columbiacountyfla.com](mailto:tbrazil@columbiacountyfla.com)

Reference: AK67340-1

Date Issued: February 2, 2016

Scope of Work: Airbus Support Side A (06/01/2017 - 05/31/2018). Airbus support includes: Comprehensive 24/7 telephone support, Software bug fixes, and Software upgrades.

**VESTA® 9-1-1**

Qty.	Part No	Description	Unit Price	U/M	Total
1	04000-68005-RNWL	<b>VM Medium Server Bundle</b> V-SVR BASIC RNWL SPT 1YR	\$95.00	EA	\$95.00
<b>VESTA® 9-1-1 Prime Standard Operations</b>					
9	SS-OPR-VSSL-1Y	SPT VPRIME 1YR	\$990.00	EA	\$8,910.00
<b>VESTA® 9-1-1 IRR Module</b>					
9	809800-35110	V911 IRR SW SPT 1YR	\$179.00	EA	\$1,611.00
<b>-----</b>					
1	809800-35120	V911 ACT VIEW SW SPT 1YR	\$630.00	EA	\$630.00
2	04000-00186	SW SPT M1000 GATEWAY 1YR	\$300.00	EA	\$600.00
<b>VESTA® 9-1-1 Subtotal</b>					<b>\$11,846.00</b>

**VESTA® Analytics**

Qty.	Part No	Description	Unit Price	U/M	Total
9	SA-MSG-ALSL-1Y	<b>VESTA® Analytics - Standard Multi Product Purchase</b> SPT V-ANLYT STD 1YR	\$117.00	EA	\$1,053.00
<b>VESTA® Analytics Subtotal</b>					<b>\$1,053.00</b>

**VESTA® Locate**

Qty.	Part No	Description	Unit Price	U/M	Total
9	809800-11406	<b>VESTA® Locate Mapping Multi Product Purchase</b> V-LOC SPT RNW 1YR	\$630.00	EA	\$5,670.00
<b>VESTA® Locate Subtotal</b>					<b>\$5,670.00</b>

**VESTA® DataSync**

Qty.	Part No	Description	Unit Price	U/M	Total
1	809800-01369	<b>VESTA® DataSync 4.1 (LAN)</b> ORDS HOST SPT 1YR	\$540.00	EA	\$540.00
9	809800-01364	ORDS CLIENT SPT 1YR	\$27.00	EA	\$243.00
<b>VESTA® DataSync Subtotal</b>					<b>\$783.00</b>

**VESTA® Network Management Center**

Qty.	Part No	Description	Unit Price	U/M	Total
13	809800-16231	<b>Security Management Solution</b> SEC MGMT 3.1 SVC 1YR	\$379.00	EA	\$4,927.00
<b>VESTA® Network Management Center Subtotal</b>					<b>\$4,927.00</b>

**Quote Summary**

<b>PRODUCT</b>	<b>TOTAL</b>
VESTA® 9-1-1	\$11,846.00
VESTA® Analytics	\$1,053.00
VESTA® Locate	\$5,670.00
VESTA® DataSync	\$783.00
VESTA® Network Management Center	\$4,927.00
<b>TOTAL Side A</b>	<b>\$24,279.00</b>

Disclaimers: This quote is provided for the listed contact and is not to be shared or disseminated without written consent by AK Associates. This quote null and voids any previous version. Quote is valid for 120 days.

*AK Associates provides the first line of 24/7 support to the customer through the established call out procedure. Should technical support be needed from the equipment vendor, the AK technician will act as the point of contact and agent of the customer, and will establish vendor contact and work with the vendor's representative to resolution.*



Quote Number: AK020617-705

Site (name/#): Columbia County, FL Side B (BU)

Contact: Thomas Brazil

Email: [tbrazil@columbiacountyfla.com](mailto:tbrazil@columbiacountyfla.com)

Reference: AK67340-2

Date Issued: February 6, 2017

Scope of Work: Airbus Support Side B (06/01/2017 - 05/31/2018). Airbus support includes: Comprehensive 24/7 telephone support, Software bug fixes, and Software upgrades.

**VESTA® 9-1-1**

Qty.	Part No.	Description	Unit Price	U/M	Total
1	04000-68005-RNWL	<b>VM Medium Server Bundle</b> V-SVR BASIC RNWL SPT 1YR	\$95.00	EA	\$95.00
4	SS-OPR-VSSL-1Y	<b>VESTA® 9-1-1 Licenses</b> <b>VESTA® 9-1-1 Prime Standard Operations</b> SPT VPRIME 1YR	\$990.00	EA	\$3,960.00
4	809800-35110	<b>VESTA® 9-1-1 IRR Module</b> V911 IRR SW SPT 1YR	\$179.00	EA	\$716.00
1	809800-35120	<b>VESTA® 9-1-1 Activity View</b> V911 ACT VIEW SW SPT 1YR	\$630.00	EA	\$630.00
2	04000-00186	<b>Peripherals &amp; Gateways</b> SW SPT M1000 GATEWAY 1YR	\$300.00	EA	\$600.00
<b>VESTA® 9-1-1 Subtotal</b>					<b>\$6,001.00</b>

**VESTA® Analytics**

Qty	Part No	Description	Unit Price	U/M	Total
4	SA-MSG-ALSL-1Y	<b>VESTA® Analytics - Standard Multi Product Purchase</b> SPT V-ANLYT STD 1YR	\$117.00	EA	\$468.00
<b>VESTA® Analytics Subtotal</b>					<b>\$468.00</b>

**VESTA® Locate**

Qty	Part No	Description	Unit Price	U/M	Total
4	809800-11406	<b>VESTA® Locate Mapping Multi Product Purchase</b> V-LOC SPT RNW 1YR	\$630.00	EA	\$2,520.00
<b>VESTA® Locate Subtotal</b>					<b>\$2,520.00</b>

**VESTA® DataSync**

Qty	Part No	Description	Unit Price	U/M	Total
4	809800-01364	<b>VESTA® DataSync 4.1 (LAN)</b> ORDS CLIENT SPT 1YR	\$27.00	EA	\$108.00
<b>VESTA® DataSync Subtotal</b>					<b>\$108.00</b>

**VESTA® Network Management Center**

Qty	Part No	Description	Unit Price	U/M	Total
6	809800-16231	<b>Security Management Solution</b> SEC MGMT 3.1 SVC 1YR	\$379.00	EA	\$2,274.00
<b>VESTA® Network Management Center Subtotal</b>					<b>\$2,274.00</b>



Quote Summary

PRODUCT	TOTAL
VESTA® 9-1-1	\$6,001.00
VESTA® Analytics	\$468.00
VESTA® Locate	\$2,520.00
VESTA® DataSync	\$108.00
VESTA® Network Management Center	\$2,274.00
Side B Total	\$11,371.00
Side A Total	\$24,279.00
<b>GRAND TOTAL Side A &amp; B</b>	<b>\$35,650.00</b>

Disclaimers: This quote is provided for the listed contact and is not to be shared or disseminated without written consent by AK Associates. This quote null and voids any previous version. Quote is valid for 120 days.

*AK Associates provides the first line of 24/7 support to the customer through the established call out procedure. Should technical support be needed from the equipment vendor, the AK technician will act as the point of contact and agent of the customer, and will establish vendor contact and work with the vendor's representative to resolution.*



Quote Number: AK021117-706

Site (name/#): Columbia County, FL

Contact: Thomas Brazil

Email: [tbrazil@columbiacountyfla.com](mailto:tbrazil@columbiacountyfla.com)

Reference:

Date Issued: February 11, 2017

Scope of Work: AK Elite Premier Maintenance(06/01/17 -05/31/18)

Description	Total
<p><b>AK Elite Premier Maintenance</b></p> <p>AK Elite Premier Maintenance• Includes (labor only) maintenance service for 9-1-1 systems. • Response time for minor and major outages is within (2) hours. All other non-critical maintenance issues will have a next business day response. • Remote diagnostics, will be done immediately upon receipt of service problem. • It also provides daily remote diagnostics during normal business days. If corrective action is needed it will be performed remotely or by an on-site visit. • Provides a weekly on-site preventive maintenance program during regular business hours (number of days is depending on selection of options 1 – 5 days). • Engineering- Design of PSAP, Call Routing Database, Direct trunking for VoIP, Landline and Wireless trunking. Design of i3 NENA technology for text messaging. • Project Management / Consulting Services included for all new projects associated with PSAP management, design and implementation. • Technical Support for system implementation for all new technologies including i3 VoIP, CAD integration, text messaging and Mapping API integration. Includes no incurred costs for expansion, move of equipment and upgrades of the existing 9-1-1 system.</p> <p><i>AK Associates provides the first line of 24/7 support to the customer through the established call out procedure. Should technical support be needed from the equipment vendor, the AK technician will act as the point of contact and agent of the customer, and will establish vendor contact and work with the vendor's representative to resolution.</i></p>	<p><b>\$28,430.00</b></p>
<p><b>Total</b></p>	<p><b>\$28,430.00</b></p>

Disclaimers: This quote is provided for the listed contact and is not to be shared or disseminated without written consent by AK Associates. This quote null and voids any previous version. Quote is valid for 120 days.





Quote Number: AK021117-706

Site (name/#): Columbia County, FL

Contact: Thomas Brazil

Email: [tbrazil@columbiacountyfla.com](mailto:tbrazil@columbiacountyfla.com)

Reference:

Date Issued: February 11, 2017

Scope of Work: AK Elite Premier Maintenance(06/01/17 -05/31/18)

Description	Total
<p><b>AK Elite Premier Maintenance</b></p>	<p><b>\$28,430.00</b></p>
<p>AK Elite Premier Maintenance• Includes (labor only) maintenance service for 9-1-1 systems. • Response time for minor and major outages is within (2) hours. All other non-critical maintenance issues will have a next business day response. • Remote diagnostics, will be done immediately upon receipt of service problem. • It also provides daily remote diagnostics during normal business days. If corrective action is needed it will be performed remotely or by an on-site visit. • Provides a weekly on-site preventive maintenance program during regular business hours (number of days is depending on selection of options 1 – 5 days).• Engineering- Design of PSAP, Call Routing Database, Direct trunking for VoIP, Landline and Wireless trunking. Design of i3 NENA technology for text messaging. • Project Management / Consulting Services included for all new projects associated with PSAP management, design and implementation. • Technical Support for system implementation for all new technologies including i3 VoIP, CAD integration, text messaging and Mapping API integration. Includes no incurred costs for expansion, move of equipment and upgrades of the existing 9-1-1 system.</p> <p><i>AK Associates provides the first line of 24/7 support to the customer through the established call out procedure. Should technical support be needed from the equipment vendor, the AK technician will act as the point of contact and agent of the customer, and will establish vendor contact and work with the vendor's representative to resolution.</i></p>	
<p><b>Total</b></p>	<p><b>\$28,430.00</b></p>

Disclaimers: This quote is provided for the listed contact and is not to be shared or disseminated without written consent by AK Associates. This quote null and voids any previous version. Quote is valid for 120 days.



# 4

COLUMBIA COUNTY BOARD OF COUNTY COMMISSIONERS
AGENDA ITEM REQUEST FORM

The Board of County Commissioners meets the 1st and 3rd Thursday of each month at 5:30 p.m. in the Columbia County School Board Administrative Complex Auditorium, 372 West Duval Street, Lake City, Florida 32055. All agenda items are due in the Board's office one week prior to the meeting date.

Today's Date: February 13, 2017 Meeting Date: March 2, 2017

Name: Shayne Morgan Department: Emergency Management/911 (non-emergency)

Division Manager's Signature: Ben Scott

1. Nature and purpose of agenda item:

To approve the lease agreement between Emergency Management and Marcotek for an upgrade in Xerox copy machine used by Emergency Management.

Attach any correspondence information, documents and forms for action i.e., contract agreements, quotes, memorandums, etc.

2. Fiscal impact on current budget.

Is this a budgeted item? [ ] N/A [X] Yes Account No. 001-2112-525-3044 [ ] No Please list the proposed budget amendment to fund this request

Budget Amendment Number: Fund:

FROM: TO: AMOUNT:

For Use of County Manger Only:

[X] Consent Item [ ] Discussion Item



# COLUMBIA COUNTY EMERGENCY MANAGEMENT

P.O. Box 1787, Lake City, FL 32056-1787

Telephone (386) 758-1125 or (386) 758-1126 • Fax (386) 752-9644

EOC Hotline Number (386) 719-7530

www.columbiacountyem.com

## MEMORANDUM

DATE: February 13, 2017

TO: Scott Ward, Assistant County Manager

FR: Shayne Morgan, F.P.E.M., Emergency Management Director

RE: Xerox Lease

A handwritten signature in blue ink, appearing to be "SM", is written over the "FR:" line of the memorandum.

---

Currently Emergency Management leases a copy machine through Marcotek and has for many years. I have attached a lease agreement to upgrade the machine that we currently use in the Emergency Operations Center (EOC) with a newer model machine. The machine I am currently using was one that came out of dispatch when they needed to upgrade a year and a half or so ago.

Emergency Management will actually save a few dollars with this upgrade in the machine. Currently we pay approximately \$223 dollars a month. Depending on the copy amount at a maximum it would save emergency management about \$4 but in low copy months, it could save the department even more than that.

If you have any questions please let me know.

# Lease Agreement



Customer: COLUMBIA, COUNTY OF

BillTo: COLUMBIA COUNTY  
EMERGENCY MANAGEMENT  
PO BOX 1529  
LAKE CITY, FL 32056-1529  
Negotiated Contract : 072537800

Install: COLUMBIA COUNTY  
EMERGENCY MANAGEMENT  
263 NW LAKE CITY AVE  
LAKE CITY, FL 32055-4820

## Solution

Item	Product Description	Agreement Information	Trade Information	Requested Install Date
1. W7855PT (W7855PT TANDEM)	- Ck1.5 - 1 Line Fax - Office Finisher Lx - Customer Ed - Analyst Services	Lease Term: 60 months Purchase Option: \$600.00	- Xerox WC7525P S/N XKK422400 Trade-In as of Payment 21	2/24/2017

## Monthly Pricing

Item	Lease Minimum Payment	Print Charges			Maintenance Plan Features
		Meter	Volume Band	Per Print Rate	
1. W7855PT	\$189.35	1: Black and White Impressions	All Prints	\$0.0115	- Consumable Supplies Included for all prints - Pricing Fixed for Term
		2: Color Impressions	All Prints	\$0.0916	
Total	\$189.35	Minimum Payments (Excluding Applicable Taxes)			

## Authorized Signature

Customer acknowledges receipt of the terms of this agreement which consists of 3 pages including this face page.

Signer: \_\_\_\_\_

Phone: ( )-

Signature: \_\_\_\_\_

Date: \_\_\_\_\_

Thank You for your business!  
This Agreement is proudly presented by Xerox and

**Keith Norris**  
**(386)755-7969**

For information on your Xerox Account, go to  
[www.xerox.com/AccountManagement](http://www.xerox.com/AccountManagement)





### Introductory Pricing

You are receiving special Introductory Pricing. Your Minimum Payment for Products identified in the Pricing Detail table below will be adjusted during the Introductory Pricing period as set forth in the Pricing Detail table, and will be different from the Minimum Payment during the balance of this Agreement. The Pricing Detail table illustrates how the Minimum Payment will be affected during the Introductory Pricing period.

Monthly Minimum Pricing Summary for the item to be installed at this location during the 3 Month Introductory Period				
	Month 1	Month 2	Month 3	Full Amount
Product	\$189.35	\$189.35	\$189.35	\$189.35
<b>Total</b>	<b>\$189.35</b>	<b>\$189.35</b>	<b>\$189.35</b>	<b>\$189.35</b>

#### Introductory Pricing Detail for Each Applicable Item

Item	Contract Months	Product Minimum Payment	Print Charges			Maintenance Plan Features
			Meter	Volume Band	Per Print Rate	
1. W7855PT	1 - 3	\$189.35	1: Black and White Impressions	All Prints	\$0.0022	<ul style="list-style-type: none"> <li>- Full Service Maintenance Included for all prints</li> <li>- Consumable Supplies charge only</li> </ul>
			2: Color Impressions	All Prints	\$0.0510	



**INTRODUCTION:**

**1. NEGOTIATED CONTRACT.** The Products are subject solely to the terms in the Negotiated Contract identified on the face of this Agreement, and, for any option you have selected that is not addressed in the Negotiated Contract, the then-current standard Xerox terms for such option.

**PRICING PLAN/OFFERING SELECTED:**

**2. FIXED PRICING.** If "Pricing Fixed for Term" is identified in Maintenance Plan Features, the maintenance component of the Minimum Payment and Print Charges will not increase during the initial Term of this Agreement.

**GENERAL TERMS & CONDITIONS:**

**3. REMOTE SERVICES.** Certain models of Equipment are supported and serviced using data that is automatically collected by Xerox or transmitted to or from Xerox by the Equipment connected to your network ("Remote Data") via electronic transmission to a secure off-site location ("Remote Data Access"). Remote Data Access also enables Xerox to transmit Releases of Software to you and to remotely diagnose and modify Equipment to repair and correct malfunctions. Examples of Remote Data include

product registration, meter read, supply level, Equipment configuration and settings, software version, and problem/fault code data. Remote Data may be used by Xerox for billing, report generation, supplies replenishment, support services, recommending additional products and services, and product improvement/development purposes. Remote Data will be transmitted to and from you in a secure manner specified by Xerox. Remote Data Access will not allow Xerox to read, view or download the content of any of your documents or other information residing on or passing through the Equipment or your information management systems. You grant the right to Xerox, without charge, to conduct Remote Data Access for the purposes described above. Upon Xerox's request, you will provide contact information for Equipment such as name and address of your contact and IP and physical addresses/locations of Equipment. You will enable Remote Data Access via a method prescribed by Xerox, and you will provide reasonable assistance to allow Xerox to provide Remote Data Access. Unless Xerox deems Equipment incapable of Remote Data Access, you will ensure that Remote Data Access is maintained at all times Maintenance Services are being performed.



# 5

COLUMBIA COUNTY BOARD OF COUNTY COMMISSIONERS
AGENDA ITEM REQUEST FORM

The Board of County Commissioners meets the 1st and 3rd Thursday of each month at 5:30 p.m. in the Columbia County School Board Administrative Complex Auditorium, 372 West Duval Street, Lake City, Florida 32055. All agenda items are due in the Board's office one week prior to the meeting date.

Today's Date: February 22, 2017 Meeting Date: March 2, 2017

Name: Lisa Roberts Department: Human Resources

Division Manager's Signature: [Handwritten Signature]

- 1. Nature and purpose of agenda item:
(1) Worxtime Amendment - Service Agreement

Attach any correspondence information, documents and forms for action i.e., contract agreements, quotes, memorandums, etc.

2. Fiscal impact on current budget.

Is this a budgeted item? [ ] N/A [X] Yes Account No. 001-1000-511.30-34 [ ] No Please list the proposed budget amendment to fund this request

Budget Amendment Number: Fund:

FROM: TO: AMOUNT:

For Use of County Manger Only: [X] Consent Item [ ] Discussion Item



District No. 1 - Ronald Williams  
District No. 2 - Rusty DePratter  
District No. 3 - Bucky Nash  
District No. 4 - Everett Phillips  
District No. 5 - Tim Murphy



**BOARD OF COUNTY COMMISSIONERS • COLUMBIA COUNTY**

**MEMORANDUM**

**TO:** Board of County Commissioners  
**FROM:** Lisa K.B. Roberts, Human Resources Director  
**DATE:** February 22, 2017  
**SUBJECT:** Worxtime Amendment to Service Agreement

Attached you will find an Amendment to Service Agreement between Worxtime, LLC and the Columbia County Board of County Commissioners whereby Worxtime agrees to mail forms 1095-C to all benefit eligible employee for calendar year 2016, subsequent years and renewal years to Columbia County employees that have been offered coverage during the applicable reporting year. The cost of mailing the 1095-C forms will be \$2.50 per mailed 1095-C form. The quantity is to be determined after confirmation of eligible employees.

The above stated service was not inclusive in the original three year Worxtime Service agreement; therefore, annually the County must approve an amendment in order for Worxtime to provide fulfillment of mailing the 1095-C forms.

The 1095-C is a tax form which is required by law (Affordable Care Act) to be distributed to all full-time and full-time equivalent employees, for anyone that enrolled in coverage, regardless of full-time status. The 1095-C includes healthcare coverage information and serves as a way for employees to prove to the IRS that they had healthcare for 2016.

Your consideration of the above stated Amendment is greatly appreciated.

XC: Worxtime Agreement File

BOARD MEETS FIRST THURSDAY AT 5:30 P.M.  
AND THIRD THURSDAY AT 5:30 P.M.



**AMENDMENT TO  
SERVICE AGREEMENT**

THIS AMENDMENT TO THE SERVICE AGREEMENT ("Amendment") is entered into as of \_\_\_\_\_ by and between WORXTIME LLC, a Georgia limited liability company ("Worxtime") and **COLUMBIA COUNTY FLORIDA BOARD OF COUNTY COMMISSIONERS**, specifically defined herein shall have the same meaning as set forth in the Agreement.

WHEREAS, Worxtime and Customer entered into that certain Service Agreement, ("Agreement"), with respect to the Worxtime program and certain services; and

WHEREAS, Worxtime and Customer agree to amend the Agreement as more particularly set forth herein;

NOW THEREFORE, in consideration of the mutual promises and covenants contained herein and in the Agreement, Worxtime and Customer hereby agree as follows:

1. **Mailing of Forms 1095C.** Worxtime agrees to mail 1095C forms to all benefit eligible employees for calendar year 2016, subsequent years and renewal years to Your employees that have been offered coverage during the applicable reporting year. The determination as to which employees are to be mailed 1095C forms and to what address such forms will be mailed shall be based on the data provided by You;
2. Columbia County Florida Board of County Commissioners agrees to pay \$2.50 per mailed 1095C form to Worxtime, LLC for this service;
3. The Quantity is to be determined and will be determined after confirmation of Eligible Employees.
4. Except as expressly amended hereby, all the remaining provisions of the Subscription Agreement shall remain in full force and effect.

The parties hereby agree and consent to the terms and conditions of these Amendments to the stated Subscription Agreement and acknowledge such by executing the Amendments below.

<b>Executed by Customer:</b>	<u>Columbia County Florida Board of County Commissioners</u>	<b>Accepted By:</b>	<u>Worxtime, LLC</u>
<b>Signature:</b>	_____	<b>Signature:</b>	_____
<b>Printed Name:</b>	_____	<b>Printed Name:</b>	<u>Tearle D. Bagwell</u>
<b>Title:</b>	<u>Chairman</u>	<b>Title:</b>	<u>Managing Partner</u>
<b>Date Signed:</b>	_____	<b>Date Signed:</b>	_____
<b>Address:</b>	<u>P.O. Box 1529 Lake City, FL 32056</u>	<b>Address:</b>	<u>360B Quality Circle Suite 220 Huntsville, Alabama 35640</u>



# 6

COLUMBIA COUNTY BOARD OF COUNTY COMMISSIONERS
AGENDA ITEM REQUEST FORM

The Board of County Commissioners meets the 1st and 3rd Thursday of each month at 5:30 p.m. in the Columbia County School Board Administrative Complex Auditorium, 372 West Duval Street, Lake City, Florida 32055. All agenda items are due in the Board's office one week prior to the meeting date.

Today's Date: February 21, 2017 Meeting Date: March 2, 2017

Name: Kevin Kirby Department: Public Works Department

Division Manager's Signature: [Handwritten Signature]

1. Nature and purpose of agenda item:

Utility permit from AT&T for the purpose of the placement of 2196' for 48 buried fiber cable to be trenched and 3727' of 24 buried fiber cable also to be trenched within the right of ways on SW Tustenuggee Ave and SW Bedenbaugh Ln.

Attach any correspondence information, documents and forms for action i.e., contract agreements, quotes, memorandums, etc.

2. Fiscal impact on current budget.

Is this a budgeted item? [X] N/A [ ] Yes Account No. [ ] No Please list the proposed budget amendment to fund this request

Budget Amendment Number: Fund:

FROM: TO: AMOUNT:

For Use of County Manger Only:

[X] Consent Item [ ] Discussion Item

**COLUMBIA COUNTY BOARD OF COUNTY COMISSIONERS  
UTILITY PERMIT**

Date: 02/13/2017 Permit No. \_\_\_\_\_ County Road \_\_\_\_\_ Section No. \_\_\_\_\_

Permittee AT&T Authorized representative - David Stapleton, RTS Associates, LLC

Address 4220 International Pkwy, Suite 400, Atlanta, GA 30354 Telephone Number 770-270-1212 ext 6001

Requesting permission from Columbia County, Florida, hereinafter called the County, to contract, operate and maintain AT&T job # 73E61175N proposes the placement of 2196' for 48 buried fiber cable to be trenched and 3727' of 24 buried fiber cable also to be trenched within the right of ways on SW Tustenuggee Av and SW Bedenbaugh Ln.

FROM: 1841 SW Tustenuggee Av TO: 1550 SW Bedenbaugh Ln

Submitted for the Utility Owner by: David Stapleton(Project Manager) 02/13/2017  
Typed Name & Title Signature Date

1. Permittee declares that prior to filing this application it has determined the location of all existing utilities, both aerial and underground and the accurate locations are shown on the plans attached hereto and made a part of this application. Proposed work is within corporate limits of Municipality: YES ( ) NO (x). If YES: LAKE CITY ( ) FORT WHITE ( ). A letter of notification was mailed on N/A to the following utility owners \_\_\_\_\_

2. The Columbia County Public Works Director shall be notified twenty-four (24) hours prior to starting work and again immediately upon completion of work. The Public Works Director is Kevin Kirby, located at P.O. Box 969, Lake City, FL 32056 Telephone Number (386) 752-5955. The PERMITTEE's employee responsible for Maintenance of Traffic is Randy Vaughn Telephone Number (352) 378-9991 (This name may be provided at the time of the 24 hour notice to starting work.)

3. This PERMITTEE shall commence actual construction in good faith within 30 days after issuance of permit, and shall be completed within 60 days after permitted work has begun. If the beginning date is more than 60 days from date of permit approval, then PERMITTEE must review the permit with the Columbia County Public Works Director to make sure no changes have occurred in the transportation facility that would affect the permitted construction.

4. The construction and maintenance of such utility shall not interfere with the property and rights of a prior PERMITTEE.

5. It is expressly stipulated that this permit is a license for permissive use only and that the placing of utilities upon public property pursuant to this permit shall not operate to create or vest any property right in said holder.

6. Pursuant to Section 337-403(1), Florida Statutes, whenever necessary for the construction, repair, improvement, maintenance, safe and efficient operation, alteration or relocation of all, or any portion of said transportation facility as determined by the Columbia County Public Works Director and/or County Engineer, any or all utilities and appurtenances authorized hereunder, shall be immediately removed from said transportation facility or reset or

relocated thereon as required by the Columbia County Public Works Director and/or County Engineer and at the expense of the PERMITTEE.

7. In case of non-compliance with the County's requirements in effect as of the approval date of this permit, this permit void and the facility will have to be brought into compliance or removed from the right of way at no cost to the County.

8. It is understood and agreed that the rights and privileges herein set out are granted only to the extent of the County's right, title and interest in the land to be entered upon and used by the PERMITTEE, and the PERMITTEE will, at all times, and to the extent permitted by law, assume all risk of and indemnify, defend, and save harmless Columbia County, Florida from any and all loss, damage, cost or expense arising in any manner on account of the exercise or attempted exercise by said PERMITTEE of the aforesaid right and privileges.

9. During construction, all safety regulations of the County shall be observed and the PERMITTEE must take measures, including pacing and the display of safety devices that may be necessary in order to safely conduct the public through the project area in accordance with the Federal Manual on Uniform Traffic Control Devices, as amended for highways.

10. Should the PERMITTEE be desirous of keeping its utilities in place and out of service, the PERMITTEE, by execution of this permit acknowledges its present and continuing ownership of its utilities located between \_\_\_\_\_ N/A \_\_\_\_\_ and \_\_\_\_\_ N/A \_\_\_\_\_ within the County's right of way as set forth above. PERMITTEE, as its sole expense, shall promptly remove said out of service utilities whenever Columbia County Public Works Director and/or County Engineer determines said removal is in the public interest.

11. Special instructions: Minimum cover of thirty inches (30") will be required at all locations. Columbia County will not be financially responsible for any damage to facilities with less than thirty inches (30") cover. Cables shall not be located within driveway ditches.

12. Additional Stipulations: \_\_\_\_\_  
\_\_\_\_\_  
\_\_\_\_\_  
\_\_\_\_\_  
\_\_\_\_\_

It is understood and agreed that commencement by the PERMITTEE is acknowledgment and acceptance of the binding nature of these specialist instructions.

Submitted By: AT&T Authorized representative - David Stapleton - RTS Associates, LLC  
Permittee

Place Corporate Seal

DStapleton (Project Manager)  
Signature and Title

\_\_\_\_\_  
Attested

Utilities Permit  
Page three  
Revised: 8/17/00

Recommended for Approval:

Signature: 

Title: ASS County MANAGER

Date: 02-20-17

Approval by Board of County Commissioners, Columbia County, Florida:

YES ( )      NO ( )

Date Approved: \_\_\_\_\_

Chairman's Signature: \_\_\_\_\_

*Rec'd  
2-17-17*



**CALL BEFORE YOU DIG**  
 FLORIDA STATE  
 OF PUBLIC UTILITIES  
 DIAL  
 811  
 1-800-432-4779



THIS SHALL BE THE RESPONSIBILITY OF THE CONTRACTOR TO CONTACT ALL UTILITIES BEFORE BEGINNING CONSTRUCTION TO VERIFY THE LOCATION OF UTILITIES SHOWN ON THE PLAN AND TO OBTAIN ANY NECESSARY PERMISSIONS, TRANSMISSION CERTIFICATIONS TO THE LOCATION OF ALL UNDERGROUND UTILITIES IS WITHHELD.

**SCOPE OF WORK:**  
 73E61175N WILL BE PLACING CABLE ALONG SW TUSTENUGGEE AV AND SW BEDENBAUGH LN FROM AN EXISTING HANDHOLE NEAR 2066 SW TUSTENUGGEE AV TO 1550 SW BEDENBAUGH LN. THE CABLE WILL BE TRENCHED ALONG THE RIGHT-OF-WAY FOR APPROXIMATELY 5900 FT. THE CABLE WILL THEN TURN AND CROSS UNDER SW BEDENBAUGH LN TO A NEW HANDHOLE AT THE EDGE OF THE RIGHT-OF-WAY. HERE, THE CABLE WILL ENTER CUSTOMER CONDUIT AND EXIT THE COUNTY RIGHT-OF-WAY. DUCT WILL BE PLACED UNDER ALL DRIVEWAY AND ROAD CROSSINGS, BY DIRECTIONAL BORING. THE CABLE WILL BE PULLED THRU THE DUCT AND CONTINUE ALONG THE TRENCH.

VICINITY MAP

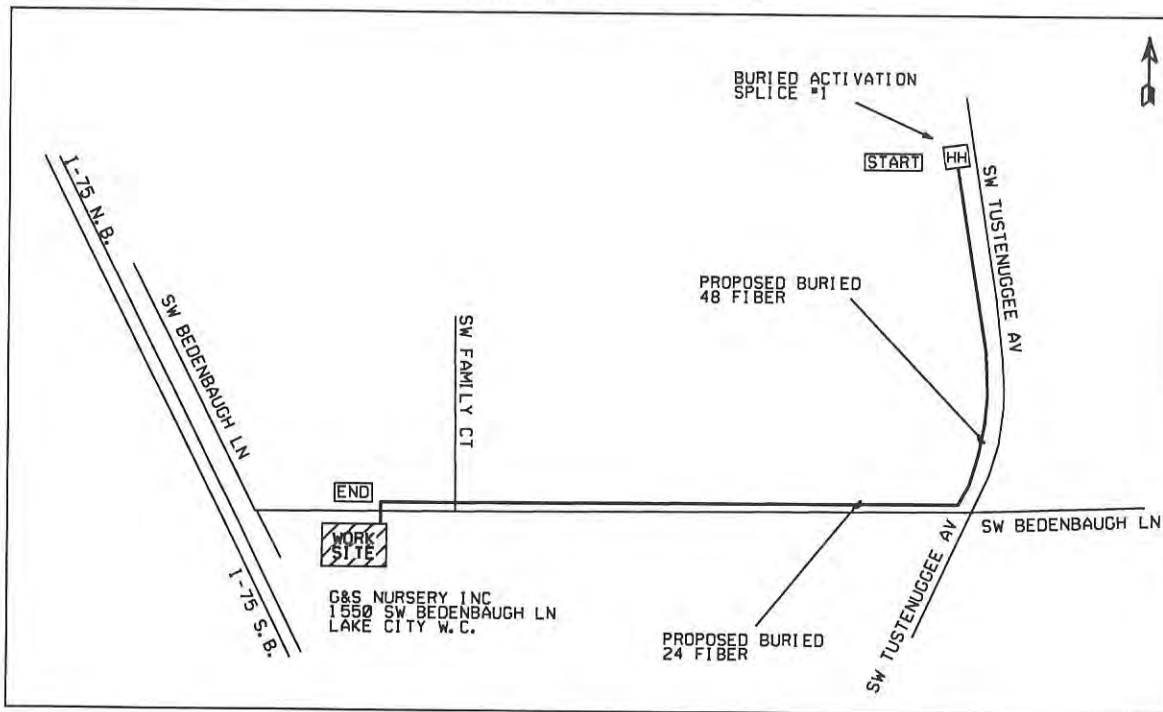

BURIED SYMBOL LEGEND		
Proposed	Existing	Description
— B —	— B —	BURIED CABLE
— BJ —	— BJ —	BUR JOINT-TRENCH
		ENCLOSURE
		MANHOLE
		PIPE/CONDUIT
— CA-MKR —	— CA-MKR —	CABLE MARKER
--- B ---	--- B ---	BURIED SVC WIRE
--- BJ ---	--- BJ ---	JOINT-TRENCH SVC
-----	N/A	BORE
	N/A	CUT PAYEMENT
	N/A	SPLICING PIT
200' @ (24")	N/A	TRENCH LENGTH/DEPTH

ATTSE	
PROPOSED TELEPHONE FACILITIES ON RIGHT OF WAY OF COLUMBIA COUNTY	
SW BEDENBAUGH LN	
Exchanges:	386752
Designers:	Fernandez, Chris
Phone:	904-727-1554
Authorizations:	73E61175N
Dwg.	1 of 5



- ① CABLE
- ② CABLE
- ③ CABLE
- ④ CABLE
- ⑤ CABLE
- ⑥ CABLE
- ⑦ CABLE
- ⑧ CABLE
- ⑨ CABLE
- ⑩ CABLE
- ⑫ HANDHOLE

⑬ PROPOSED BURIED FIBER CABLE  
2196'

TRENCH Ø30"  
MIN DEPTH

**CALL BEFORE YOU DIG**



STATE OF KANSAS  
DIAL 811  
1-800-432-4770

IT IS THE CONTRACTOR'S RESPONSIBILITY TO CONTACT UTILITY COMPANIES PRIOR TO ANY CONSTRUCTION AT THE LOCATION OF UTILITIES SHOWN ON THE PLAN AND APPROXIMATE TO AND ABOVE, THE DEPTH, THROUGH CERTIFICATION TO THE LOCATION OF ALL UNDERGROUND UTILITIES IS WITHHELD.

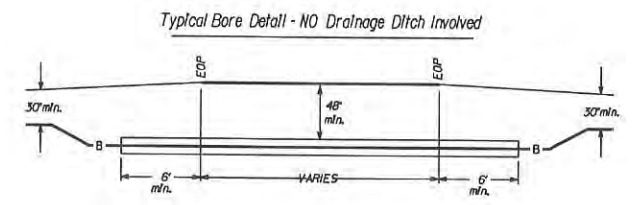
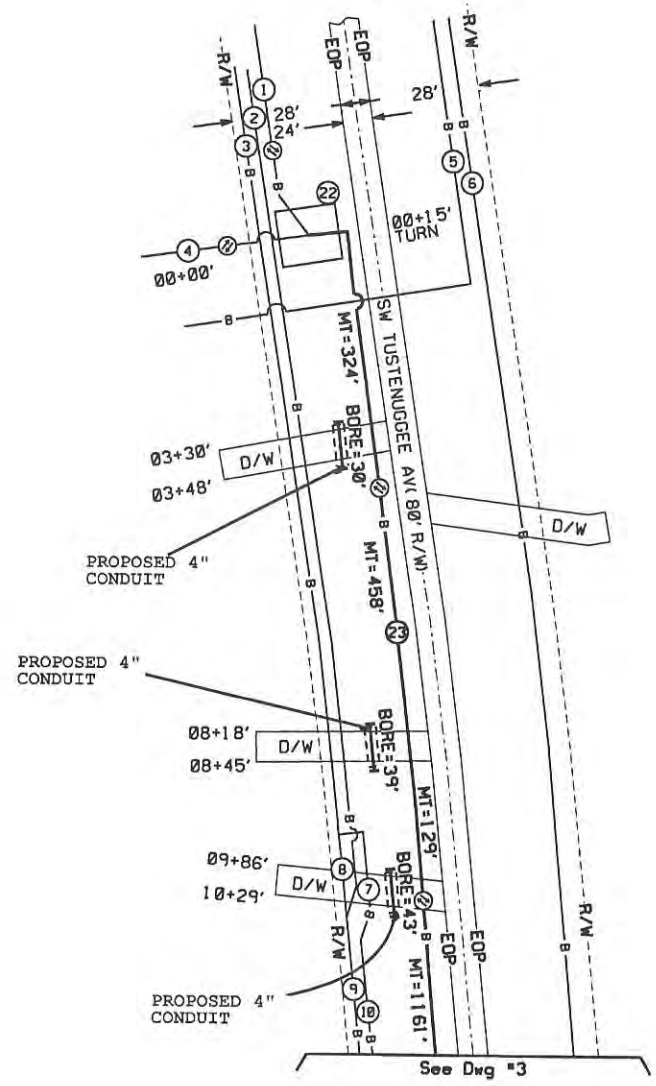
<b>ATTSE</b>	
PROPOSED TELEPHONE FACILITIES ON RIGHT OF WAY OF COLUMBIA COUNTY	
SW BEDENBAUGH LN	
Exchange:	386752
Designer:	Fernandez, Chris
Phone:	904-727-1554
Authorization:	73E61175N
Dwg.	2 of 5

6 CABLE

9 CABLE

10 CABLE

11 CABLE

12 CABLE

13 CABLE

14 CABLE

15 CABLE

23 PROPOSED BURIED FIBER CABLE 2196'

24 PROPOSED BURIED FIBER CABLE 3727'

TRENCH 30" MIN DEPTH

CALL BEFORE YOU DIG



IT IS THE CONTRACTOR'S RESPONSIBILITY TO CONTACT UTILITY COMPANIES PRIOR TO ANY CONSTRUCTION AS THE LOCATION DETAILS SHOWN ON THIS PLAN ARE APPROXIMATE AND POSSIBLY INCOMPLETE. THE OWNER'S RESPONSIBILITY IS TO VERIFY THE LOCATION OF ALL UNDERGROUND UTILITIES IS WITHIN TOLERANCE.

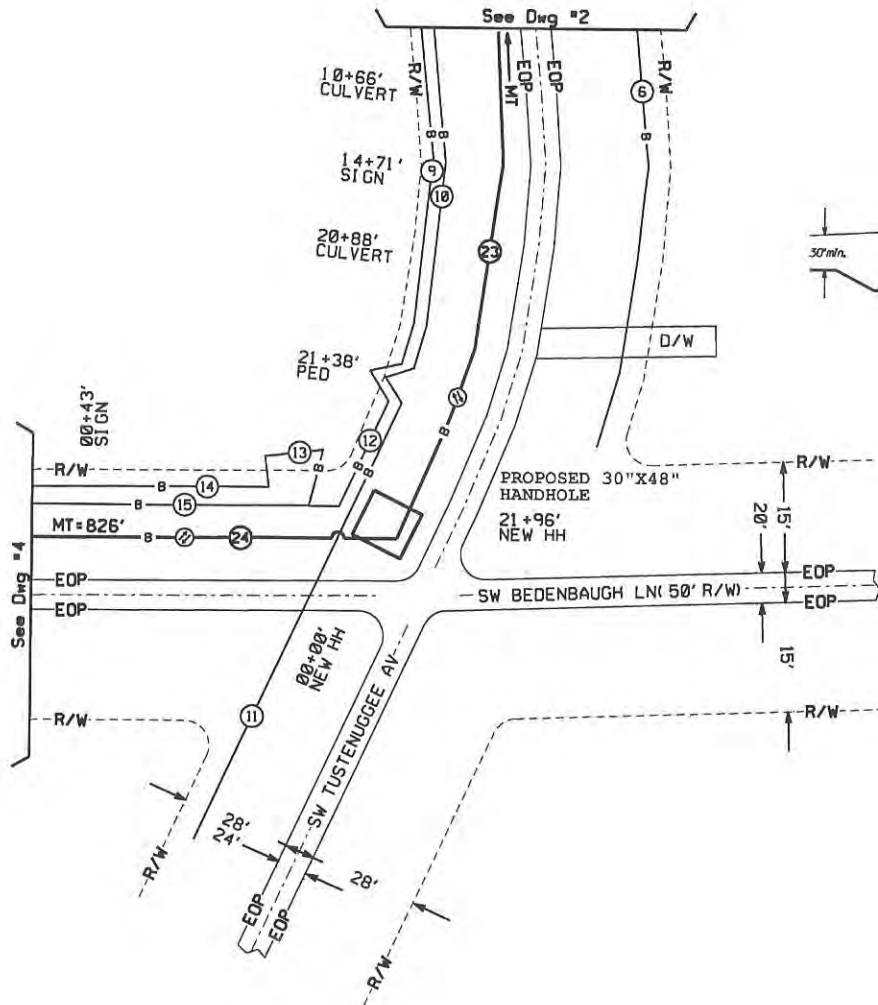

Typical Bore Detail - NO Drainage Ditch Involved

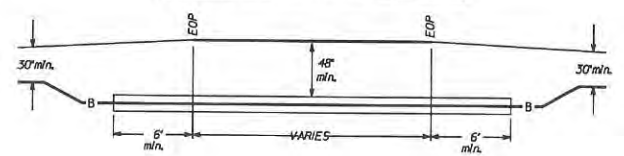

<b>ATTSE</b>	
PROPOSED TELEPHONE FACILITIES ON RIGHT OF WAY OF COLUMBIA COUNTY	
SW BEDENBAUGH LN	
Exchanges:	386752
Designers:	Fernandez, Chris
Phone:	904-727-1554
Authorization:	73E61175N
Dwg.	3 of 5



- 14 CABLE
- 15 CABLE
- 16 CABLE
- 17 CABLE
- 18 CABLE
- 19 CABLE

**CALL BEFORE YOU DIG**

800-432-4770  
 1-800-432-4770

IT IS THE CONTRACTOR'S RESPONSIBILITY TO CONTACT UTILITY COMPANIES PRIOR TO ANY CONSTRUCTION OF THE LOCATION OF UTILITIES NEARBY ON THE PLAT AND APPROXIMATE AND POSITIVE LOCATIONS. THEREFORE VERIFICATION TO THE LOCATION OF ALL UNDERGROUND UTILITIES IS MANDATED.



Typical Bore Detail - NO Drainage Ditch Involved

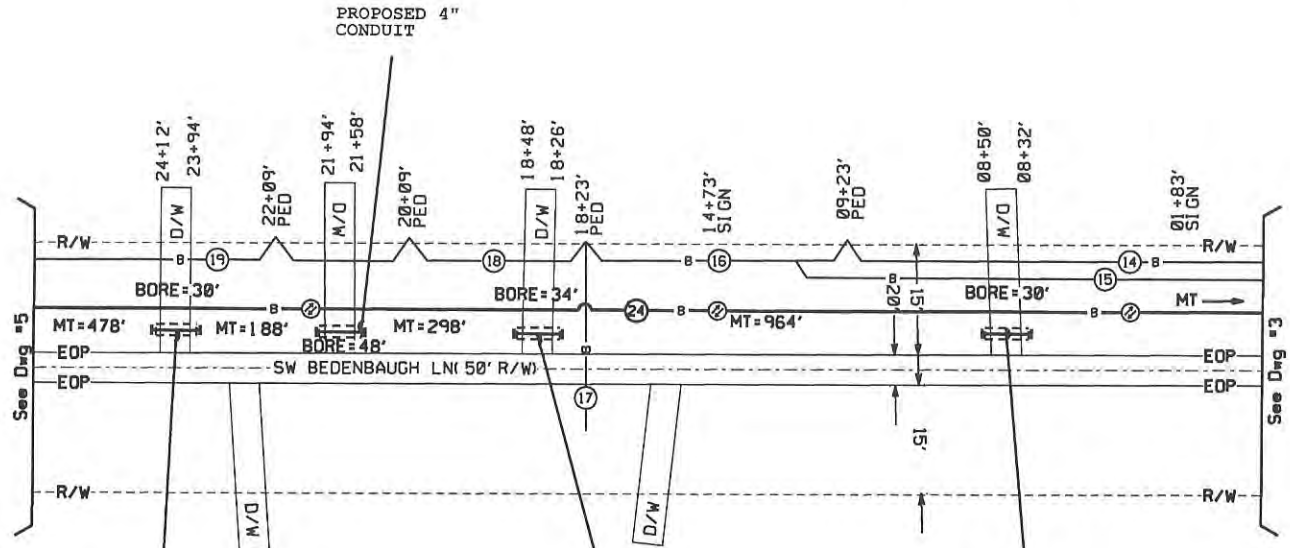
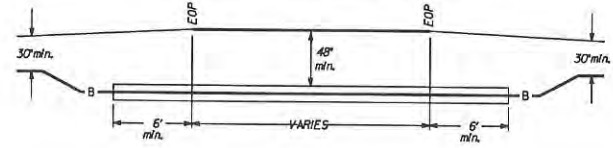

<b>ATTSE</b>	
PROPOSED TELEPHONE FACILITIES ON RIGHT OF WAY OF COLUMBIA COUNTY	
SW BEDENBAUGH LN	
Exchange:	386752
Designer:	Fernandez, Chris
Phone:	904-727-1554
Authorization:	73E61175N
Dwg.	4 of 5

19 CABLE

20 CABLE

21 CABLE

24 PROPOSED BURIED FIBER CABLE  
3727'

TRENCH 30"  
MIN DEPTH

Typical Bore Detail - NO Drainage Ditch Involved

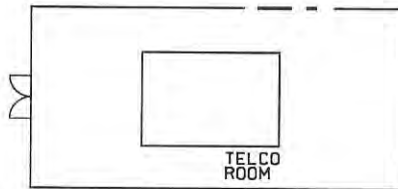
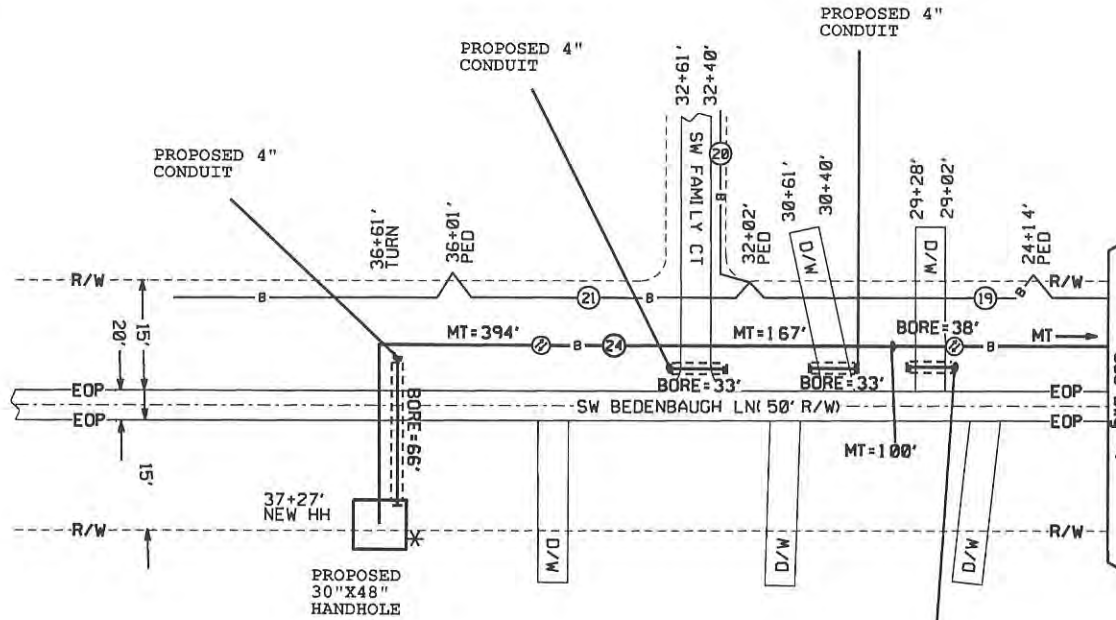
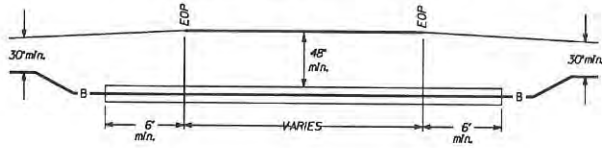

G&S NURSERY INC  
1550 SW BEDENBAUGH LN  
LAKE CITY W.C.

CALL BEFORE YOU DIG



THIS FULL SIZE DATE BEFORE YOU DIG  
IT IS THE CONTRACTOR'S RESPONSIBILITY  
TO CONTACT UTILITY COMPANIES PRIOR  
TO ANY CONSTRUCTION TO DETERMINE THE LOCATION  
OF UTILITIES SHOWN ON THE PLAN. ALL  
OPERATIONS AND WORK SHALL BE COMPLETE.  
THE CONTRACTOR SHALL BE RESPONSIBLE FOR  
THE LOCATION OF ALL UNDERGROUND UTILITIES  
IS WITHHELD.

### ATTSE

PROPOSED TELEPHONE FACILITIES  
ON RIGHT OF WAY OF  
COLUMBIA COUNTY

SW BEDENBAUGH LN

Exchange:	386752
Designer:	Fernandez, Chris
Phone:	904-727-1554
Authorization:	73E61175N
Dwg. 5 of 5	



**CALL BEFORE YOU DIG**  
 FLORIDA STATE  
 OF PUBLIC UTILITIES  
 DIAL  
 811  
 1-800-432-4779  
THIS CALL DOES NOT RELIEVE YOU OF THE RESPONSIBILITY TO CONTACT UTILITY COMPANIES PRIOR TO ANY CONSTRUCTION AND THE LOCATION OF UTILITIES SHOWN ON THE PLAN ARE GENERAL ONLY. POSITIVE IDENTIFICATION OF UTILITIES TO THE LOCATION OF ALL UNDERGROUND UTILITIES IS VITIAL.



**SCOPE OF WORK:**  
 73E61175N WILL BE PLACING CABLE ALONG SW TUSTENUGGEE AV AND SW BEDENBAUGH LN FROM AN EXISTING HANDHOLE NEAR 2066 SW TUSTENUGGEE AV TO 1550 SW BEDENBAUGH LN. THE CABLE WILL BE TRENCHED ALONG THE RIGHT-OF-WAY FOR APPROXIMATELY 5900 FT. THE CABLE WILL THEN TURN AND CROSS UNDER SW BEDENBAUGH LN TO A NEW HANDHOLE AT THE EDGE OF THE RIGHT-OF-WAY. HERE, THE CABLE WILL ENTER CUSTOMER CONDUIT AND EXIT THE COUNTY RIGHT-OF-WAY. DUCT WILL BE PLACED UNDER ALL DRIVEWAY AND ROAD CROSSINGS, BY DIRECTIONAL BORING. THE CABLE WILL BE PULLED THRU THE DUCT AND CONTINUE ALONG THE TRENCH.

VICINITY MAP

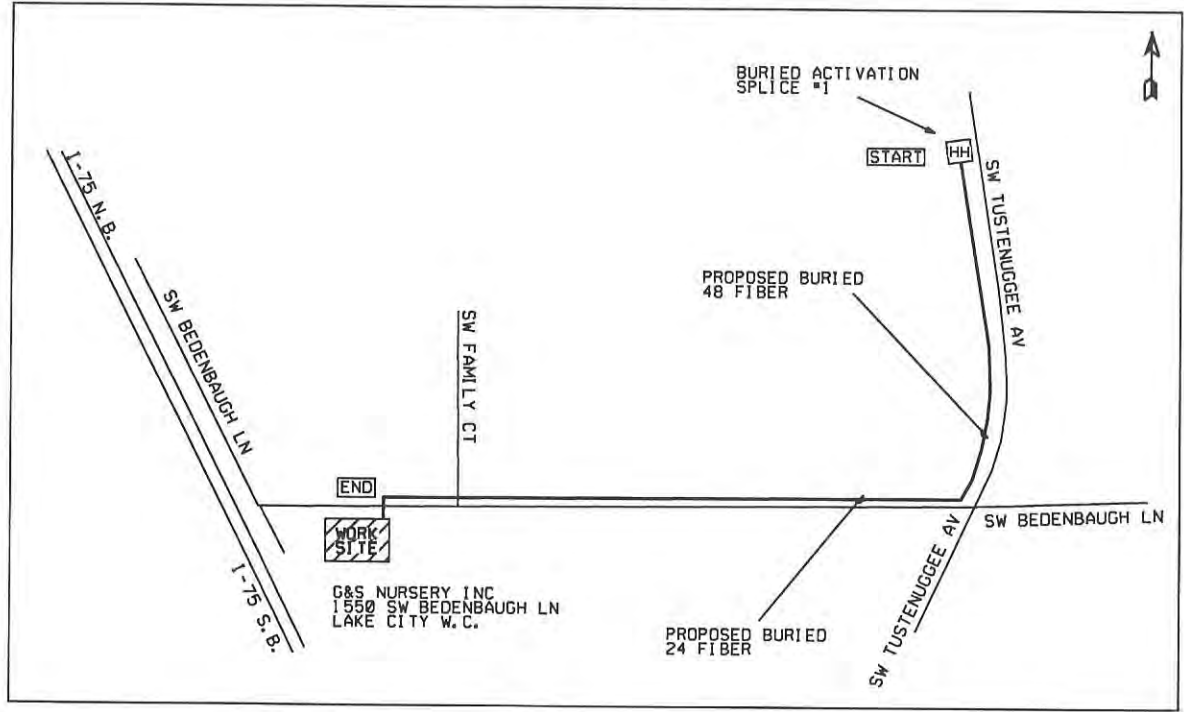

**BURIED SYMBOL LEGEND**

Proposed	Existing	Description
— B —	— B —	BURIED CABLE
— BJ —	— BJ —	BUR JOINT-TRENCH
		ENCLOSURE
		MANHOLE
		PIPE/CONDUIT
— CA-MKR —	— CA-MKR —	CABLE MARKER
--- B ---	--- B ---	BURIED SVC WIRE
--- BJ ---	--- BJ ---	JOINT-TRENCH SVC
-----	N/A	BORE
	N/A	CUT PAVEMENT
	N/A	SPLICING PIT
200' @ (24")	N/A	TRENCH LENGTH

**ATTSE**

PROPOSED TELEPHONE FACILITIES ON RIGHT OF WAY OF COLUMBIA COUNTY

SW BEDENBAUGH LN

Exchange:	386752
Designer:	Fernandez, Chris
Phone:	904-727-1554
Authorizations:	73E61175N
Dwg. 1 of 5	

- ① CABLE
- ② CABLE
- ③ CABLE
- ④ CABLE
- ⑤ CABLE
- ⑥ CABLE
- ⑦ CABLE
- ⑧ CABLE
- ⑨ CABLE
- ⑩ CABLE
- ⑫ HANDHOLE

⑬ PROPOSED BURIED FIBER CABLE  
2196'

TRENCH  $\varnothing 30"$   
MIN DEPTH

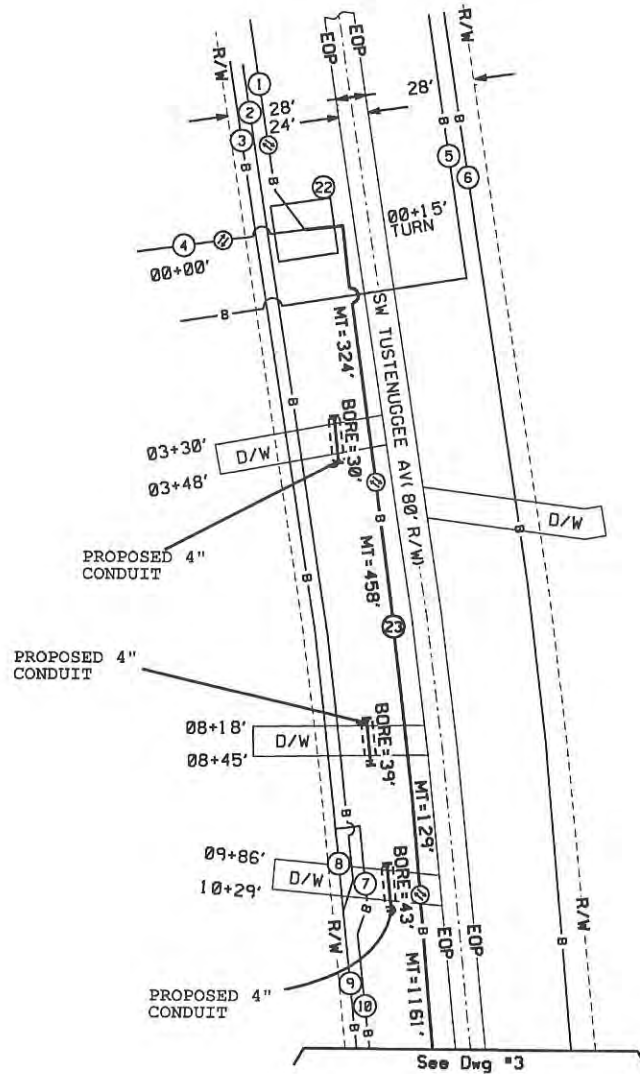

See Dwg #3

CALL BEFORE YOU DIG



IT IS THE CONTRACTOR'S RESPONSIBILITY TO CONTACT UTILITY COMPANIES PRIOR TO ANY CONSTRUCTION AS THE LOCATION OF UTILITIES SHOWN ON THIS PLAN ARE APPROXIMATE AND POSSIBLY INCOMPLETE. THEREFORE, VERIFICATION TO THE LOCATION OF ALL UNDERGROUND UTILITIES IS WITHHELD.

Typical Bore Detail - NO Drainage Ditch Involved

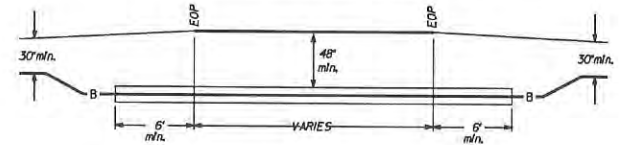

<b>ATTSE</b>	
PROPOSED TELEPHONE FACILITIES ON RIGHT OF WAY OF COLUMBIA COUNTY	
SW BEDENBAUGH LN	
Exchange:	386752
Designer:	Fernandez, Chris
Phone:	904-727-1554
Authorization:	73E61175N
Dwg. <u>  2  </u> of <u>  5  </u>	

- ⑥ CABLE
- ⑨ CABLE
- ⑩ CABLE
- ⑪ CABLE
- ⑫ CABLE
- ⑬ CABLE
- ⑭ CABLE
- ⑮ CABLE
- ⑳ PROPOSED BURIED FIBER CABLE 2196'
- ㉑ PROPOSED BURIED FIBER CABLE 3727'

TRENCH ①30" MIN DEPTH

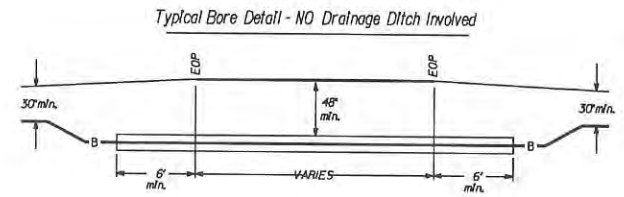
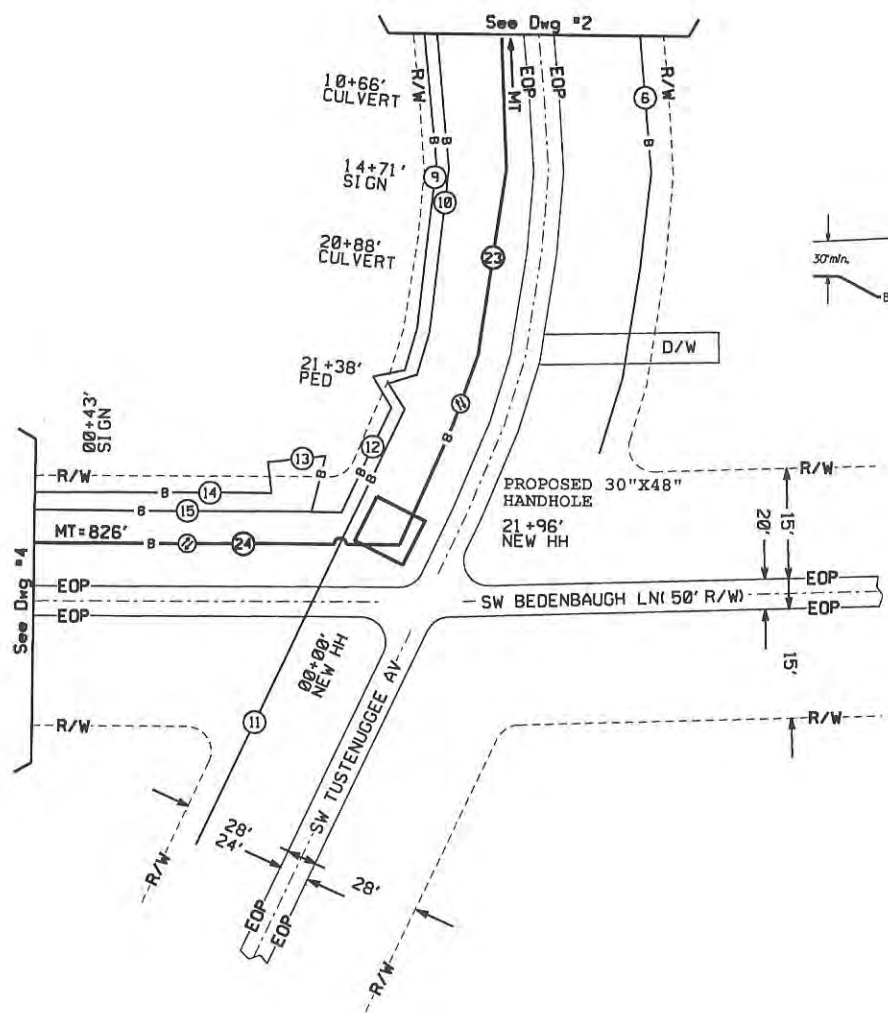

**CALL BEFORE YOU DIG**

DIAL 811  
1-800-432-4770

DO NOT FULLY DIG BEFORE YOU DIG  
IT IS THE CONTRACTOR'S RESPONSIBILITY TO CONTACT UTILITY COMPANIES PRIOR TO ANY CONSTRUCTION AND TO LOCATE UTILITIES AND MARK THEM COMPLETELY. LOCATIONS OF ALL UNDERGROUND UTILITIES IS UNRELIABLE.



<b>ATTSE</b>	
PROPOSED TELEPHONE FACILITIES ON RIGHT OF WAY OF COLUMBIA COUNTY	
SW BEDENBAUGH LN	
Exchange:	386752
Designer:	Fernandez, Chris
Phone:	904-727-1554
Authorization:	73E61175N
Dwg. 3	of 5

14 CABLE

15 CABLE

16 CABLE

17 CABLE

18 CABLE

19 CABLE

24 PROPOSED BURIED FIBER CABLE  
3727'

TRENCH @30"  
MIN DEPTH

CALL BEFORE YOU DIG



IT IS THE CONTRACTOR RESPONSIBILITY TO VERIFY UTILITY CHANGES PRIOR TO ANY CONSTRUCTION AS THE LOCATION OF UTILITIES SHOWN ON THE PLAN ARE APPROXIMATE AND POSSIBLY INCOMPLETE. THEREFORE VERIFICATION TO THE LOCATION OF ALL UNDERGROUND UTILITIES IS WITHHELD.



Typical Bore Detail - NO Drainage Ditch Involved

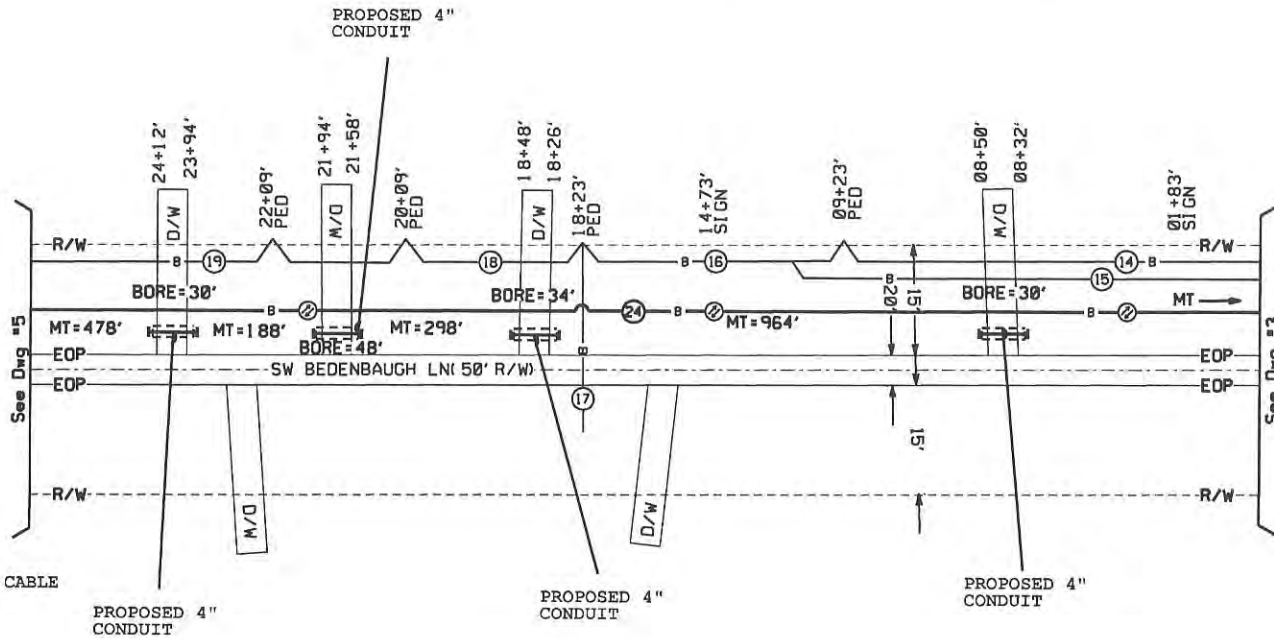
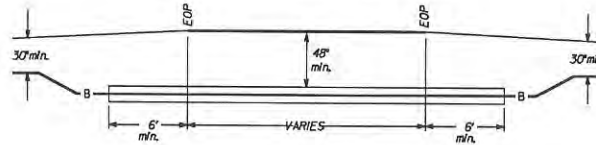

<b>ATTSE</b>	
PROPOSED TELEPHONE FACILITIES ON RIGHT OF WAY OF COLUMBIA COUNTY	
SW BEDENBAUGH LN	
Exchange:	386752
Designer:	Fernandez, Chris
Phone:	904-727-1554
Authorization:	73E61175N
Dwg. 4	of 5

19 CABLE

20 CABLE

21 CABLE

24 PROPOSED BURIED FIBER CABLE  
3727'

TRENCH @30"  
MIN DEPTH

Typical Bore Detail - NO Drainage Ditch Involved

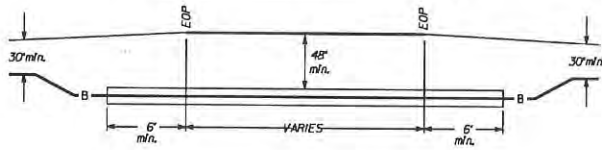

CALL BEFORE YOU DIG

 MISSOURI STATE  
 OF REVENUE  
 DIAL  
 811  
 1-800-432-4778  
 THIS SIGN MUST BE DISPLAYED BY THE CONTRACTOR RESPONSIBLE TO THE CONTRACTOR AT THE LOCATION OF ALL UTILITIES BEFORE ANY EXCAVATION OR DRILLING OPERATIONS ARE INITIATED. THE LOCATION OF ALL UTILITIES SHOULD BE VERIFIED BY THE CONTRACTOR AND SHOULD BE COMPLETELY IDENTIFIED TO THE LOCATION OF ALL UNDERGROUND UTILITIES IS WITHHELD.

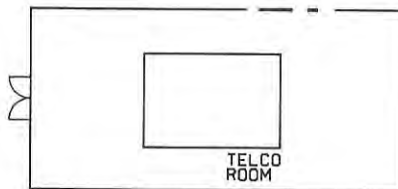
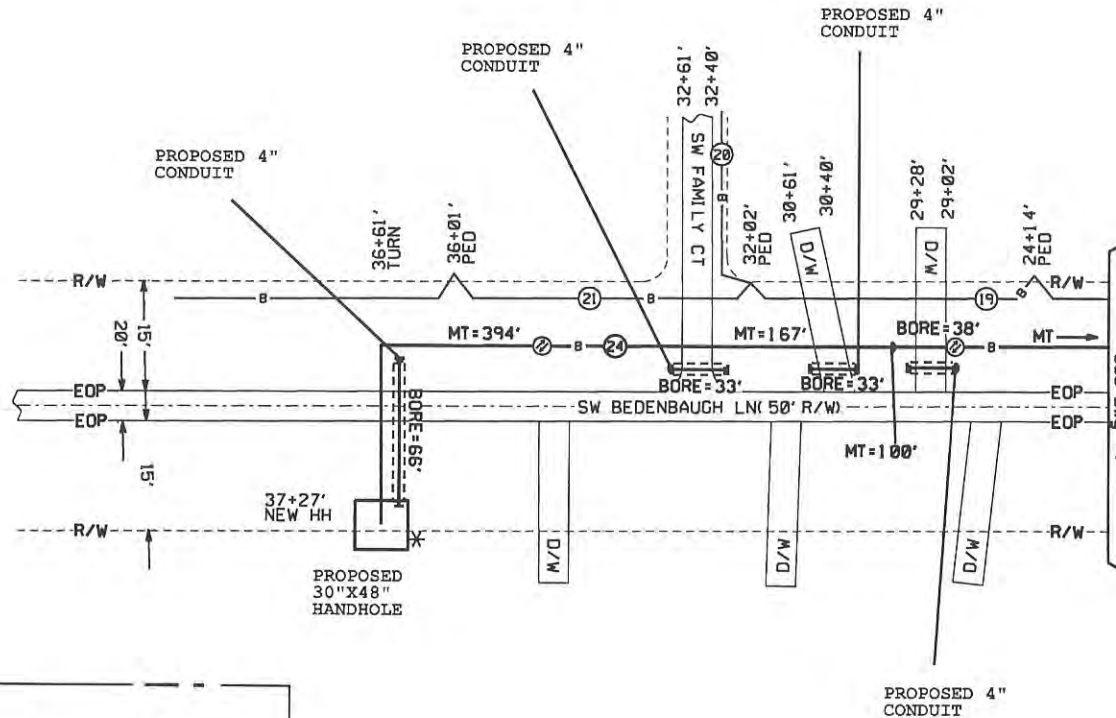

G&S NURSERY INC  
1550 SW BEDENBAUGH LN  
LAKE CITY W. C.

<b>ATTSE</b>	
PROPOSED TELEPHONE FACILITIES ON RIGHT OF WAY OF COLUMBIA COUNTY	
SW BEDENBAUGH LN	
Exchanges:	386752
Designer:	Fernandez, Chris
Phone:	904-727-1554
Authorizations:	73E61175N
Dwg. <u>5</u> of <u>5</u>	





# 7

COLUMBIA COUNTY BOARD OF COUNTY COMMISSIONERS
AGENDA ITEM REQUEST FORM

The Board of County Commissioners meets the 1st and 3rd Thursday of each month at 5:30 p.m. in the Columbia County School Board Administrative Complex Auditorium, 372 West Duval Street, Lake City, Florida 32055. All agenda items are due in the Board's office one week prior to the meeting date.

Today's Date: February 22, 2017 Meeting Date: March 2, 2017

Name: Kevin Kirby Department: Public Works Department

Division Manager's Signature: [Handwritten Signature]

1. Nature and purpose of agenda item:

Utility Permit from Florida Power and Light for the propose of installing proposed directional bore at NW Moore Farm Rd.

Attach any correspondence information, documents and forms for action i.e., contract agreements, quotes, memorandums, etc.

2. Fiscal impact on current budget.

Is this a budgeted item? [X] N/A [ ] Yes Account No. [ ] No Please list the proposed budget amendment to fund this request

Budget Amendment Number: Fund:

FROM: TO: AMOUNT:

For Use of County Manger Only: [X] Consent Item [ ] Discussion Item



**COLUMBIA COUNTY BOARD OF COUNTY COMISSIONERS  
UTILITY PERMIT**

Date: 2/16/17 Permit No. \_\_\_\_\_ County Road \_\_\_\_\_ Section No. \_\_\_\_\_

Permittee Florida Power & Light

Address 9001 Ellis Rd., Melbourne, FL 32904 Telephone Number 321-726-4804

Requesting permission from Columbia County, Florida, hereinafter called the County, to contract, operate and maintain Install proposed directional bore at NW Moores Farm Rd.

FROM: \_\_\_\_\_ TO: \_\_\_\_\_

Submitted for the Utility Owner by: Valerie Slyter-Prmt Admn. Valerie Slyter 2/16/17  
Typed Name & Title Signature Date

1. Permittee declares that prior to filing this application it has determined the location of all existing utilities, both aerial and underground and the accurate locations are shown on the plans attached hereto and made a part of this application. Proposed work is within corporate limits of Municipality: YES ( ) NO ( ). IF YES: LAKE CITY ( ) FORT WHITE ( ). A letter of notification was mailed on \_\_\_\_\_ to the following utility owners \_\_\_\_\_

2. The Columbia County Public Works Director shall be notified twenty-four (24) hours prior to starting work and again immediately upon completion of work. The Public Works Director is \_\_\_\_\_ located at \_\_\_\_\_ Telephone Number \_\_\_\_\_. The PERMITTEE's employee responsible for Maintenance of Traffic is \_\_\_\_\_ Telephone Number \_\_\_\_\_ (This name may be provided at the time of the 24 hour notice to starting work.)

3. This PERMITTEE shall commence actual construction in good faith within \_\_\_ days after issuance of permit, and shall be completed within 180 days after permitted work has begun. If the beginning date is more than 60 days from date of permit approval, then PERMITTEE must review the permit with the Columbia County Public Works Director to make sure no changes have occurred in the transportation facility that would affect the permitted construction.

4. The construction and maintenance of such utility shall not interfere with the property and rights of a prior PERMITTEE.

5. It is expressly stipulated that this permit is a license for permissive use only and that the placing of utilities upon public property pursuant to this permit shall not operate to create or vest any property right in said holder.

6. Pursuant to Section 337-403(1), Florida Statutes, whenever necessary for the construction, repair, improvement, maintenance, safe and efficient operation, alteration or relocation of all, or any portion of said transportation facility as determined by the Columbia County Public Works Director and/or County Engineer, any or all utilities and appurtenances authorized hereunder, shall be immediately removed from said transportation facility or reset or

relocated thereon as required by the Columbia County Public Works Director and/or County Engineer and at the expense of the PERMITTEE.

7. In case of non-compliance with the County's requirements in effect as of the approval date of this permit, this permit void and the facility will have to be brought into compliance or removed from the right of way at no cost to the County.

8. It is understood and agreed that the rights and privileges herein set out are granted only to the extent of the County's right, title and interest in the land to be entered upon and used by the PERMITTEE, and the PERMITTEE will, at all times, and to the extent permitted by law, assume all risk of and indemnify, defend, and save harmless Columbia County, Florida from any and all loss, damage, cost or expense arising in any manner on account of the exercise or attempted exercise by said PERMITTEE of the aforesaid right and privileges.

9. During construction, all safety regulations of the County shall be observed and the PERMITTEE must take measures, including pacing and the display of safety devices that may be necessary in order to safely conduct the public through the project area in accordance with the Federal Manual on Uniform Traffic Control Devices, as amended for highways.

10. Should the PERMITTEE be desirous of keeping its utilities in place and out of service, the PERMITTEE, by execution of this permit acknowledges its present and continuing ownership of its utilities located between \_\_\_\_\_ and \_\_\_\_\_ within the County's right of way as set forth above. PERMITTEE, as its sole expense, shall promptly remove said out of service utilities whenever Columbia County Public Works Director and/or County Engineer determines said removal is in the public interest.

11. Special instructions: Minimum cover of thirty inches (30") will be required at all locations. Columbia County will not be financially responsible for any damage to facilities with less than thirty inches (30") cover. Cables shall not be located within driveway ditches.

12. Additional Stipulations: \_\_\_\_\_  
\_\_\_\_\_  
\_\_\_\_\_  
\_\_\_\_\_  
\_\_\_\_\_

It is understood and agreed that commencement by the PERMITTEE is acknowledgment and acceptance of the binding nature of these specialist instructions.

Submitted By: Valerie Slyter  
Permittee

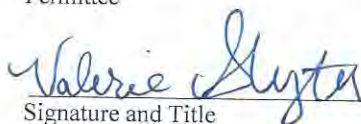
 Permit Admin.  
Signature and Title

Place Corporate Seal

\_\_\_\_\_  
Attested

Utilities Permit  
Page three  
Revised: 8/17/00

Recommended for Approval:

Signature: 

Title: ASS County Manager

Date: 02-22-17

Approval by Board of County Commissioners, Columbia County, Florida:

YES ( )      NO ( )

Date Approved: \_\_\_\_\_

Chairman's Signature: \_\_\_\_\_

*Rec'd  
2-22-17*



PLOT DATE:

DATE-PLOT

PLOT TIME:

TIME-PLOT

CAD NAME:

NAME

DRAWN BY: OCR0M81

CHECKED:

CORRECT:

APP.

COLUMBIA COUNTY

NO.

DATE

REVISION

BY

CH

CORR

APPR

RWO/SIO/ER

- LEGEND**
- PROPOSED CONC POLE --- PROPOSED PIPE
  - EXISTING POLE --- EXISTING PIPE
  - OTHER POLE
  - ⊙ EXISTING CONCRETE TRANSMISSION POLE
- NOTES:**
- PROPOSED M.O.T. INDEX 603
  - ALL CIRCUITS ARE EFFECTIVELY GROUNDED
  - POSTED SPEED LIMIT MPH: 30
  - THIS JOB IS LOCATED WITHIN THE CITY OF LAKE CITY IN COLUMBIA COUNTY, FL

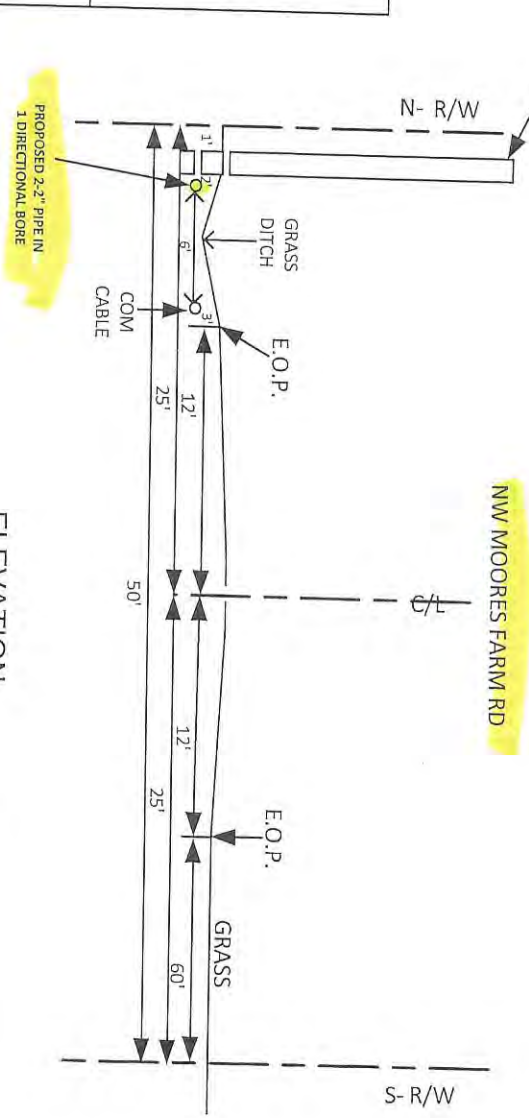

PLAN VIEW  
N.T.S.

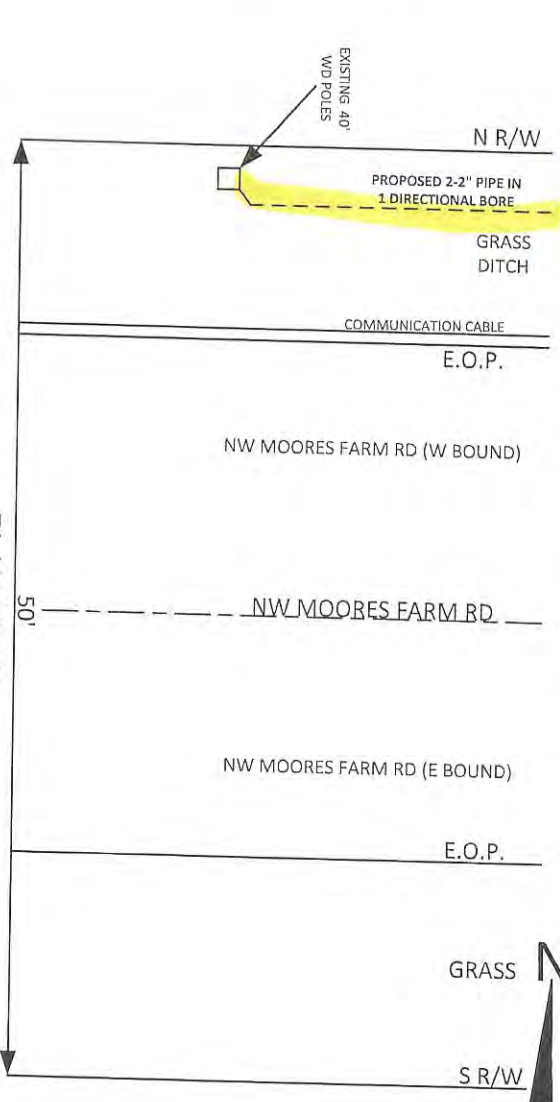

LOCATION SKETCH  
N.T.S.

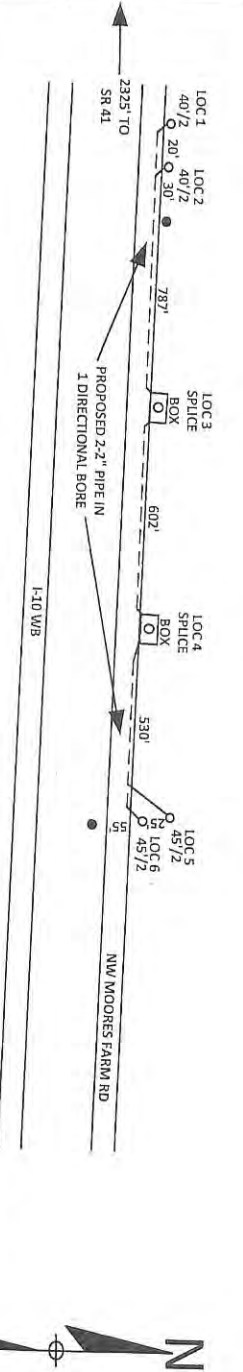

ELEVATION  
LOOKING EAST  
N.T.S.







TWP 3 SEC 12 RNG. 16 QTR

FOREIGN UTILITIES

PROP. 2-2" DIRECTIONAL BORE SR 207  
NW MOORES FARM RD  
LAKE CITY, COLUMBIA COUNTY, FL

STL. SEWER	SAN. SEWER		DATE	2/16/2017
CATV	GAS		JOB NO.	WR #7371386
WATER	SBT		MAP NO.	Z21153
			DWG. NO.	
			REV. NO.	

**SYMBOLS:**

-  Work Area
-  Channelizing Device (See Index No. 600)
-  Work Zone Sign
-  Flagger
-  Automated Flagger Assistance Devices (AFAD), With Gate
-  Lane Identification + Direction of Traffic

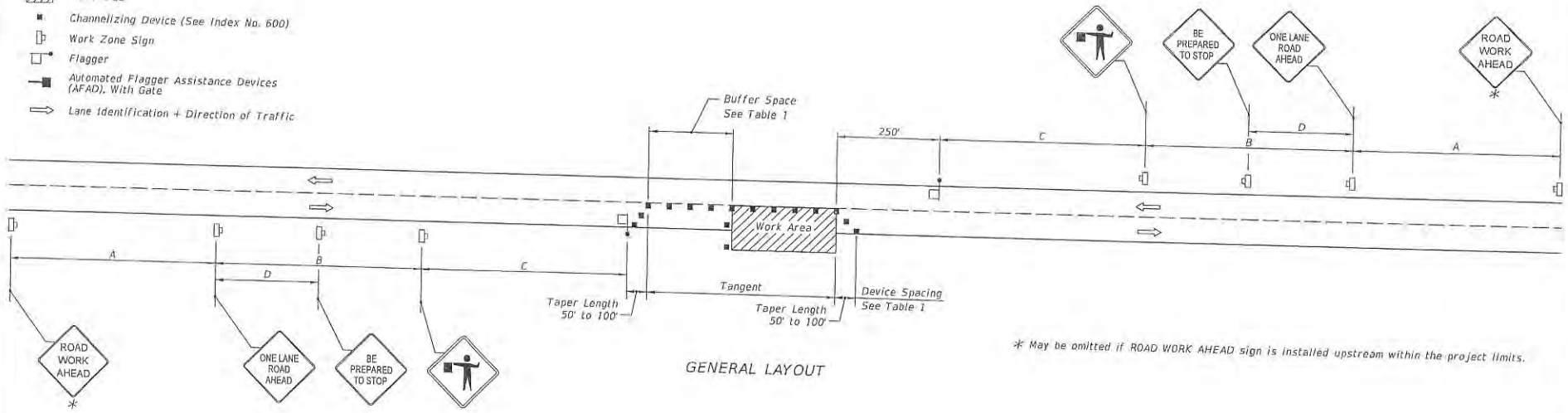

**GENERAL LAYOUT**

\* May be omitted if ROAD WORK AHEAD sign is installed upstream within the project limits.

**GENERAL NOTES:**

1. Special Conditions may be required in accordance with these notes and the following sheets.
2. If the Work Area encroaches on the Centerline, use the Layout for Temporary Lane Shift to Shoulder on Sheet 2 only if the Existing Paved Shoulder width is sufficient to provide for an 11' lane between the Work Area and the Edge of Existing Paved Shoulder. Reduce the posted speed when appropriate.
3. Temporary Raised Rumble Strips:
  - a. Use when both of the following conditions are met concurrently:
    - i. Existing Posted Speed is 50 mph or greater;
    - ii. Work duration is greater than 60 minutes.
  - b. Use a consistent Strip color throughout the work zone.
  - c. Place each Rumble Strip Set transversely across the lane at locations shown.
  - d. Use Option 1 or Option 2 as shown on Sheet 2. Use only one option throughout work zone.
4. Additional one-way control may be provided by the following means:
  - a. Flag-carrying vehicle;
  - b. Official vehicle;
  - c. Pilot vehicles;
  - d. Traffic signals.

When flaggers are the sole means of one-way control, the flaggers must be in sight of each other or in direct communication at all times.
5. When a side road intersects the highway within the TTC zone, place additional TTC devices in accordance with other applicable TCZ Indexes.
6. The two channelizing devices directly in front of the work area may be omitted provided vehicles in the work area have high-intensity rotating, flashing, oscillating, or strobe lights operating.
7. When Buffer Space cannot be attained due to geometric constraints, use the greatest attainable length, not less than 200 ft.
8. Railroad Crossings:
  - a. If an active railroad crossing is located closer to the Work Area than the queue length plus 300 feet, extend the Buffer Space as shown on Sheet 2.
  - b. If the queuing of vehicles across an active railroad crossing cannot be avoided, provide a uniformed traffic control officer or flagger at the highway-rail grade crossing to prevent vehicles from stopping within the highway-rail grade crossing, even if automatic train warning devices are in place.
9. ROAD WORK AHEAD and the BE PREPARED TO STOP signs may be omitted if all of the following conditions are met:
  - a. Work operations are 60 minutes or less.
  - b. Speed limit is 45 mph or less.
  - c. There are no sight obstructions to vehicles approaching the work area for a distance equal to the Buffer Space shown in Table 1.
  - d. Vehicles in the work area have high-intensity, rotating, flashing, oscillating, or strobe lights operating.
  - e. Volume and complexity of the roadway has been considered.
  - f. If a railroad crossing is present, vehicles will not queue across rail tracks.
  - g. AFADs are not in use.
10. See Index 600 for general TCZ requirements and additional information.
11. Automated Flagger Assistance Devices (AFADs) may be used in accordance with the Notes on Sheet 3.

**TABLE 1**

Posted Speed	DEVICE SPACING				Distance Between Signs				Buffer Space
	Maximum Spacing of Cones or Tubular Markers		Maximum Spacing of Barricades/Panels/Drums		A	B	C	D	
	On a Taper	On a Tangent	On a Taper	On a Tangent					
25	20'	50'	20'	50'	200'	200'	200'	100'	155'
30	20'	50'	20'	50'	200'	200'	200'	100'	200'
35	20'	50'	20'	50'	200'	200'	200'	100'	250'
40	20'	50'	20'	50'	200'	200'	200'	100'	305'
45	20'	50'	20'	50'	350'	350'	350'	175'	360'
50	20'	50'	20'	100'	500'	500'	500'	250'	425'
55	20'	50'	20'	100'	2640'	1500'	1000'	500'	495'
60	20'	50'	20'	100'	2640'	1500'	1000'	500'	570'
65	20'	50'	20'	100'	2640'	1500'	1000'	500'	645'
70	20'	50'	20'	100'	2640'	1500'	1000'	500'	730'

**CONDITIONS**

WHERE ANY VEHICLE, EQUIPMENT, WORKERS OR THEIR ACTIVITIES ENCROACH THE AREA BETWEEN THE CENTERLINE AND A LINE 2' OUTSIDE THE EDGE OF TRAVEL WAY.

LAST REVISION 07/01/15	REVISION	DESCRIPTION:	 2016 DESIGN STANDARDS	TWO-LANE, TWO-WAY, WORK WITHIN THE TRAVEL WAY	INDEX NO. 603	SHEET NO. 1 of 3
---------------------------	----------	--------------	---	--	------------------	---------------------

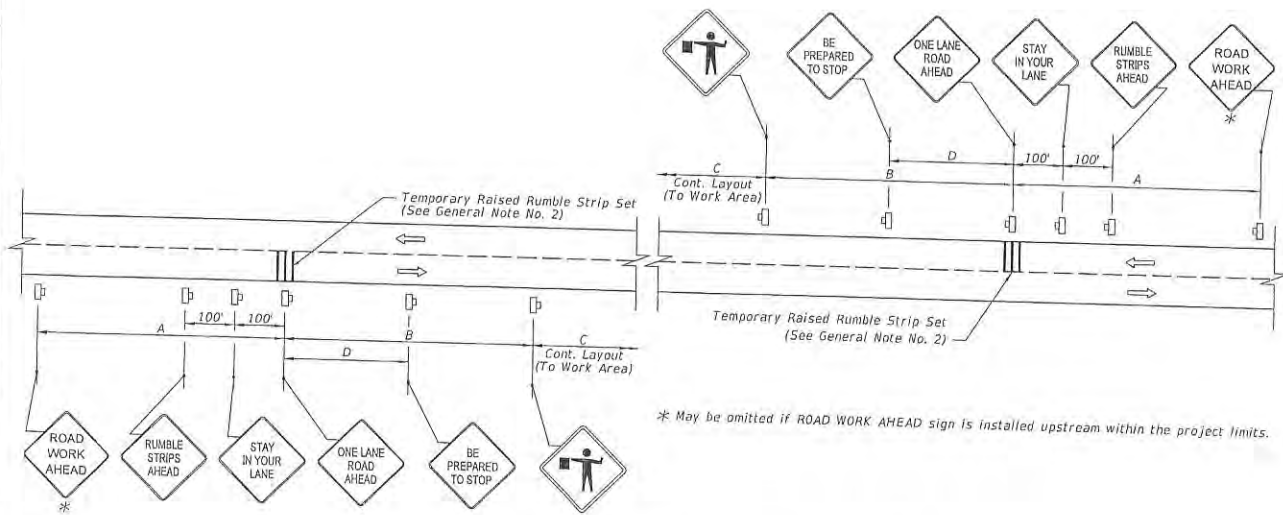

LAYOUT FOR TEMPORARY RAISED RUMBLE STRIPS WHEN REQUIRED WITH ADDITIONAL SIGNS

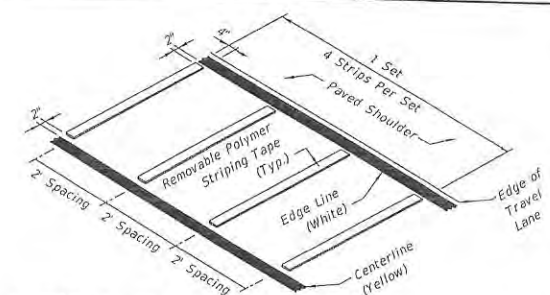

OPTION 1 - REMOVABLE POLYMER STRIPING TAPE RUMBLE STRIP SET

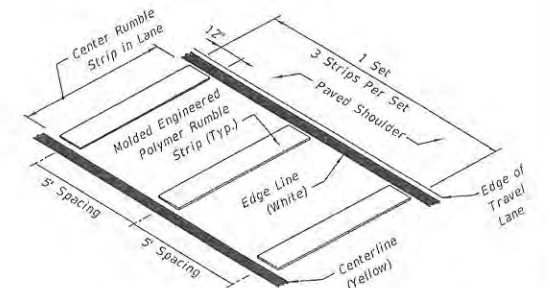

OPTION 2 - MOLDED ENGINEERED POLYMER RUMBLE STRIP SET

TEMPORARY RAISED RUMBLE STRIPS

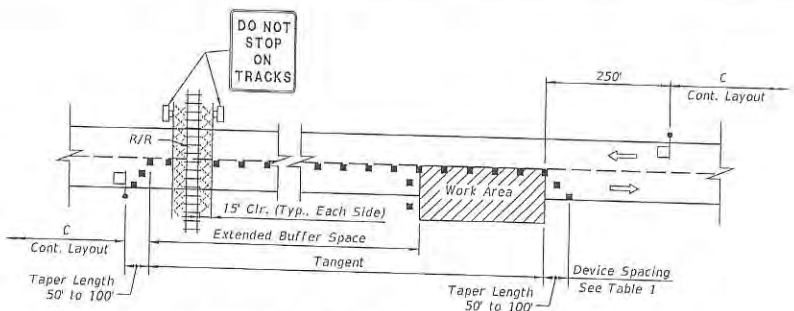

LAYOUT FOR RAILROAD CROSSING BUFFER SPACE EXTENSION

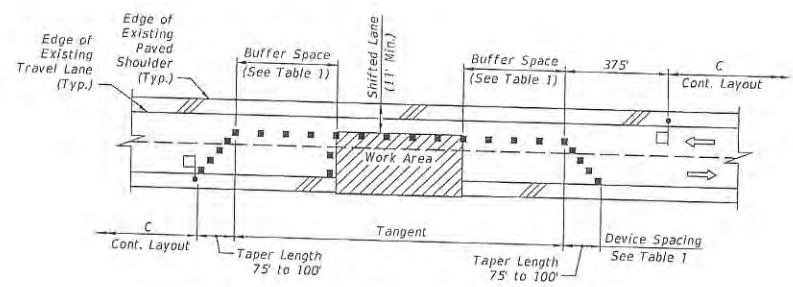

LAYOUT FOR TEMPORARY LANE SHIFT TO SHOULDER WHEN WORK AREA ENCLOSES ON THE CENTERLINE

LAST REVISION 07/01/15	REVISION	DESCRIPTION:	2016 DESIGN STANDARDS	TWO-LANE, TWO-WAY, WORK WITHIN THE TRAVEL WAY		SPECIAL CONDITIONS	
				INDEX NO. 603	SHEET NO. 2 of 3		

6/16/2015 10:46:46 AM

**AUTOMATED FLAGGER ASSISTANCE DEVICES NOTES:**

1. Illuminate the flagging station when the AFAD is used at nighttime.
2. When the AFAD is not in use, remove or cover signs and move AFAD device outside the clear zone or shield it with a barrier or crash cushion.
3. Only qualified flaggers who have been trained in the operation of the AFAD may operate the AFAD. When in use, each AFAD must be in view of and attended at all times by the flagger operating the device. Use two flaggers and one of the following methods in the deployment of AFAD's:
  - Method 1: Place an AFAD at each end of the temporary traffic control zone.
  - Method 2: Place an AFAD at one end of the temporary traffic control zone and a flagger at the opposite end.
4. A single flagger may simultaneously operate two AFAD's (Method 1) or may operate a single AFAD on one end of the temporary traffic control zone while being the flagger at the opposite end of the temporary traffic control zone (Method 2) if all four of the following conditions are present:
  - a. The flagger has an unobstructed view of the AFAD(s);
  - b. The flagger has an unobstructed view of approaching traffic in both directions;
  - c. For Method 1, the AFAD's are less than 800 ft apart. For Method 2, the AFAD and the flagger are less than 800 ft apart.
  - d. Two trained flaggers are available on-site to provide normal flagging operations should an AFAD malfunction.

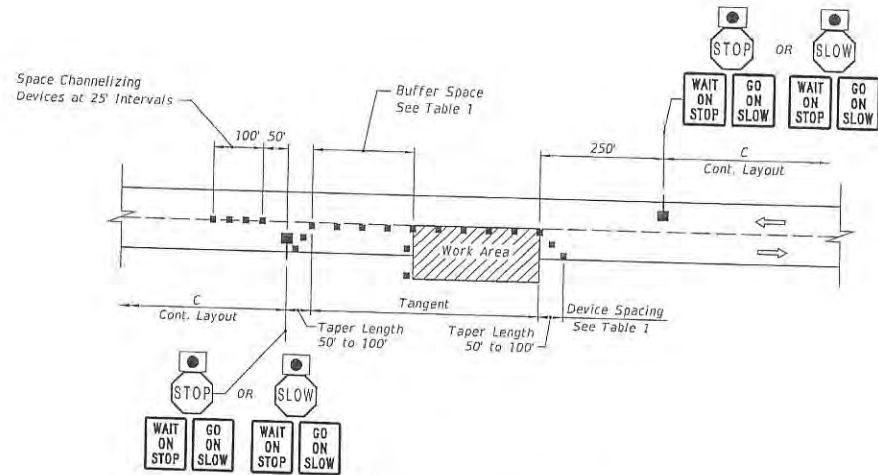

LAYOUT FOR STOP/SLOW AFAD  
METHOD 1 - 2 AFAD'S

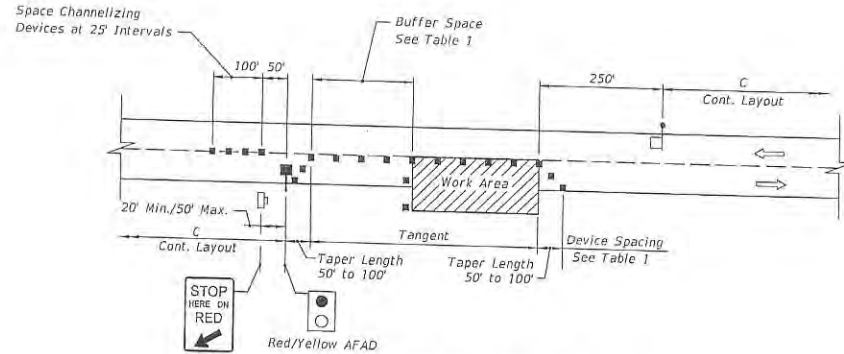

LAYOUT FOR RED/YELLOW AFAD  
METHOD 2 - 1 AFAD & FLAGGER

**AUTOMATED FLAGGER ASSISTANCE DEVICES (AFADs)**

LAST REVISION 07/01/15	REVISION	DESCRIPTION:	2016 <b>DESIGN STANDARDS</b>	<b>TWO-LANE, TWO-WAY, WORK WITHIN THE TRAVEL WAY</b>	INDEX NO. 603	SHEET NO. 3 of 3
---------------------------	----------	--------------	---------------------------------	--	------------------	---------------------



PLOT DATE:

DATE-PLOT

PLOT TIME:

TIME-PLOT

CAD NAME:

NAME

DRAWN BY: OCR0M81

CHECKED:

CORRECT:

APP.

COLUMBIA COUNTY

NO.	DATE	REVISION	BY	CH	CORR	APPR	RWO/SIO/ER
-----	------	----------	----	----	------	------	------------

- LEGEND**
- PROPOSED CONC. POLE -- PROPOSED PIPE
  - EXISTING POLE --- EXISTING PIPE
  - OTHER POLE
  - ⊙ EXISTING CONCRETE TRANSMISSION POLE
- NOTES:**
- PROPOSED M.O.T. INDEX 603
  - ALL CIRCUITS ARE EFFECTIVELY GROUNDED
  - POSTED SPEED LIMIT MPH: 30
  - THIS JOB IS LOCATED WITHIN THE CITY OF LAKE CITY IN COLUMBIA COUNTY, FL

**ELEVATION**  
LOOKING EAST  
N.T.S.

TWP 3 SEC 12 RNG. 16 QTR

FOREIGN UTILITIES

PROP. 2-2" DIRECTIONAL BORE SR 207  
NW MOORES FARM RD  
LAKE CITY, COLUMBIA COUNTY, FL

STYL SEWER	GASL SEWER	DATE	2/16/2017
CATV	GAS	JOB NO.	WR #7371386
WATER	SBT	MAP NO.	ZZ1153
		DWG. NO.	
		REV. NO.	

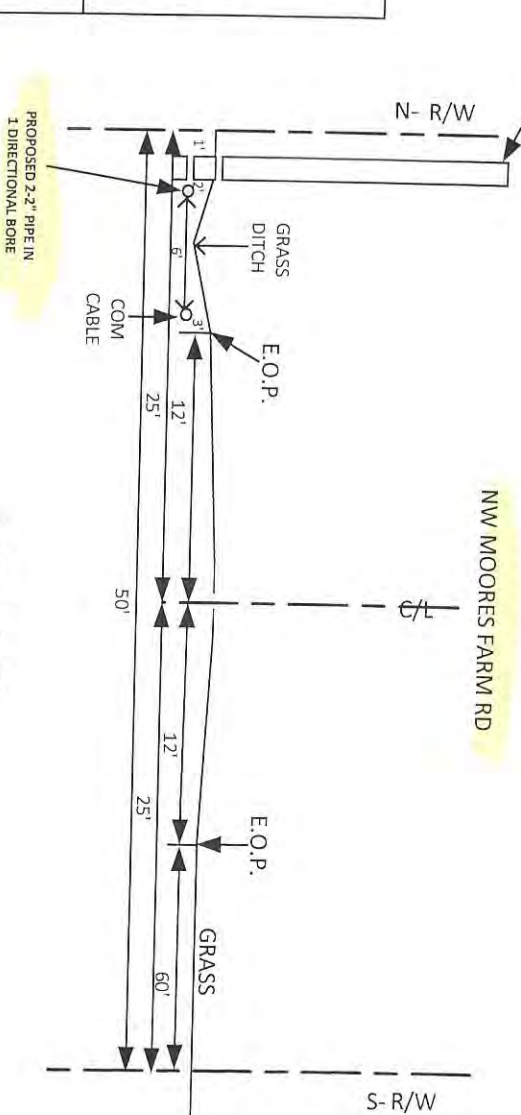

**PLAN VIEW**  
N.T.S.

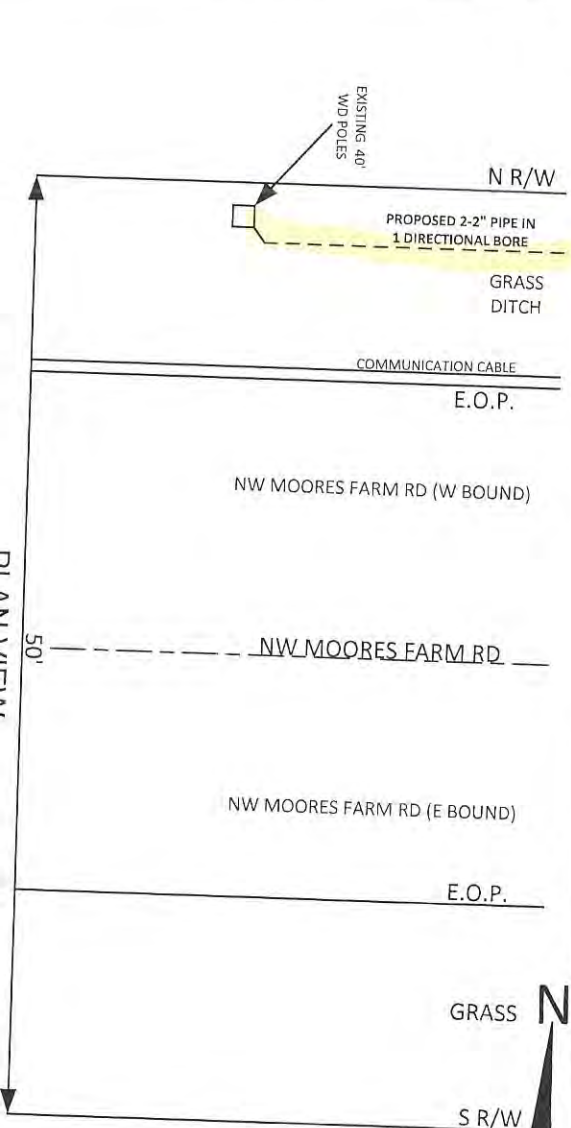







**LOCATION SKETCH**  
N.T.S.





**SYMBOLS:**

-  Work Area
-  Channelizing Device (See Index No. 600)
-  Work Zone Sign
-  Flagger
-  Automated Flagger Assistance Devices (AFAD), With Gate
-  Lane Identification + Direction of Traffic

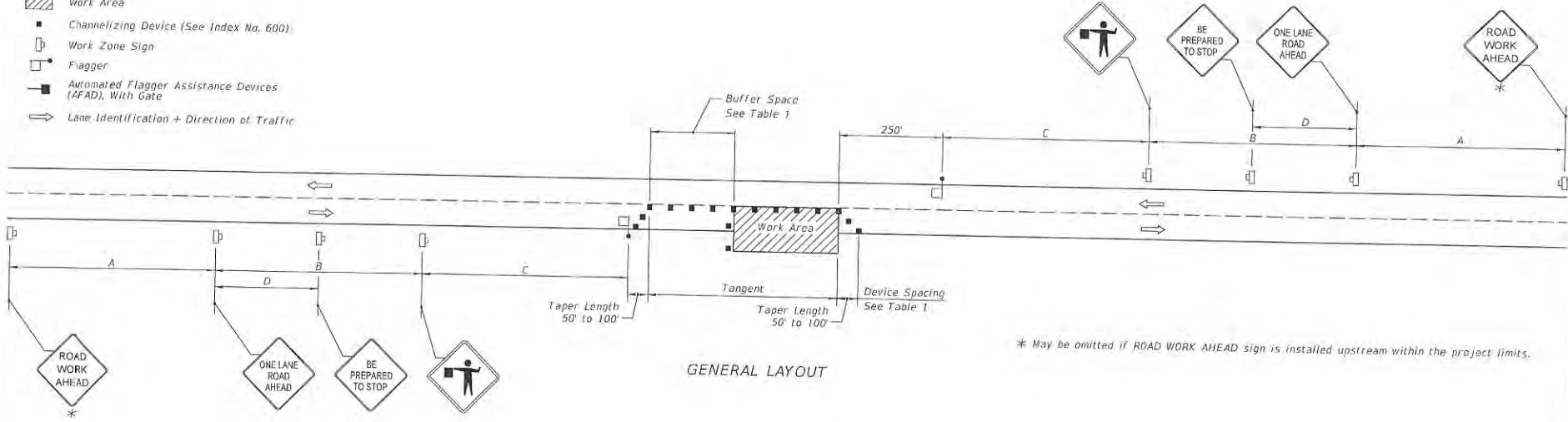

**GENERAL LAYOUT**

\* May be omitted if ROAD WORK AHEAD sign is installed upstream within the project limits.

**GENERAL NOTES:**

1. Special Conditions may be required in accordance with these notes and the following sheets.
2. If the Work Area encroaches on the Centerline, use the Layout for Temporary Lane Shift to Shoulder on Sheet 2 only if the Existing Paved Shoulder width is sufficient to provide for an 11' lane between the Work Area and the Edge of Existing Paved Shoulder. Reduce the posted speed when appropriate.
3. Temporary Raised Rumble Strips:
  - a. use when both of the following conditions are met concurrently:
    - i. Existing Posted Speed is 50 mph or greater;
    - ii. Work duration is greater than 60 minutes.
  - b. use a consistent Strip color throughout the work zone.
  - c. Place each Rumble Strip Set transversely across the lane at locations shown.
  - d. Use Option 1 or Option 2 as shown on Sheet 2. Use only one option throughout work zone.
4. Additional one-way control may be provided by the following means:
  - a. Flag-carrying vehicle;
  - b. Official vehicle;
  - c. Pilot vehicles;
  - d. Traffic signals.

When flaggers are the sole means of one-way control, the flaggers must be in sight of each other or in direct communication at all times.
5. When a side road intersects the highway within the TTC zone, place additional TTC devices in accordance with other applicable TCZ Indexes.
6. The two channelizing devices directly in front of the work area may be omitted provided vehicles in the work area have high-intensity rotating, flashing, oscillating, or strobe lights operating.
7. When Buffer Space cannot be attained due to geometric constraints, use the greatest attainable length, not less than 200 ft.
8. Railroad Crossings:
  - a. If an active railroad crossing is located closer to the Work Area than the queue length plus 300 feet, extend the Buffer Space as shown on Sheet 2.
  - b. If the queuing of vehicles across an active railroad crossing cannot be avoided, provide a uniformed traffic control officer or flagger at the highway-rail grade crossing to prevent vehicles from stopping within the highway-rail grade crossing, even if automatic train warning devices are in place.
9. ROAD WORK AHEAD and the BE PREPARED TO STOP signs may be omitted if all of the following conditions are met:
  - a. Work operations are 60 minutes or less.
  - b. Speed limit is 45 mph or less.
  - c. There are no sight obstructions to vehicles approaching the work area for a distance equal to the Buffer Space shown in Table 1.
  - d. Vehicles in the work area have high-intensity, rotating, flashing, oscillating, or strobe lights operating.
  - e. Volume and complexity of the roadway has been considered.
  - f. If a railroad crossing is present, vehicles will not queue across rail tracks.
  - g. AFADs are not in use.
10. See Index 600 for general TCZ requirements and additional information.
11. Automated Flagger Assistance Devices (AFADs) may be used in accordance with the Notes on Sheet 3.

**TABLE 1**

Posted Speed	DEVICE SPACING				Distance Between Signs				Buffer Space
	Maximum Spacing of Cones or Tubular Markers		Maximum Spacing of Type I or Type II Barricades/Panels/Drums		A	B	C	D	
	On a Taper	On a Tangent	On a Taper	On a Tangent					
25	20'	50'	20'	50'	200'	200'	200'	100'	155'
30	20'	50'	20'	50'	200'	200'	200'	100'	200'
35	20'	50'	20'	50'	200'	200'	200'	100'	250'
40	20'	50'	20'	50'	200'	200'	200'	100'	305'
45	20'	50'	20'	50'	350'	350'	350'	175'	360'
50	20'	50'	20'	100'	500'	500'	500'	250'	425'
55	20'	50'	20'	100'	2640'	1500'	1000'	500'	495'
60	20'	50'	20'	100'	2640'	1500'	1000'	500'	570'
65	20'	50'	20'	100'	2640'	1500'	1000'	500'	645'
70	20'	50'	20'	100'	2640'	1500'	1000'	500'	730'

**CONDITIONS**  
 WHERE ANY VEHICLE, EQUIPMENT, WORKERS OR THEIR ACTIVITIES ENCROACH THE AREA BETWEEN THE CENTERLINE AND A LINE 2' OUTSIDE THE EDGE OF TRAVEL WAY.

LAST REVISION 07/01/15	REVISION	DESCRIPTION:	 2016 DESIGN STANDARDS	TWO-LANE, TWO-WAY, WORK WITHIN THE TRAVEL WAY	INDEX NO. 603	SHEET NO. 1 of 3
---------------------------	----------	--------------	---	--	------------------	---------------------

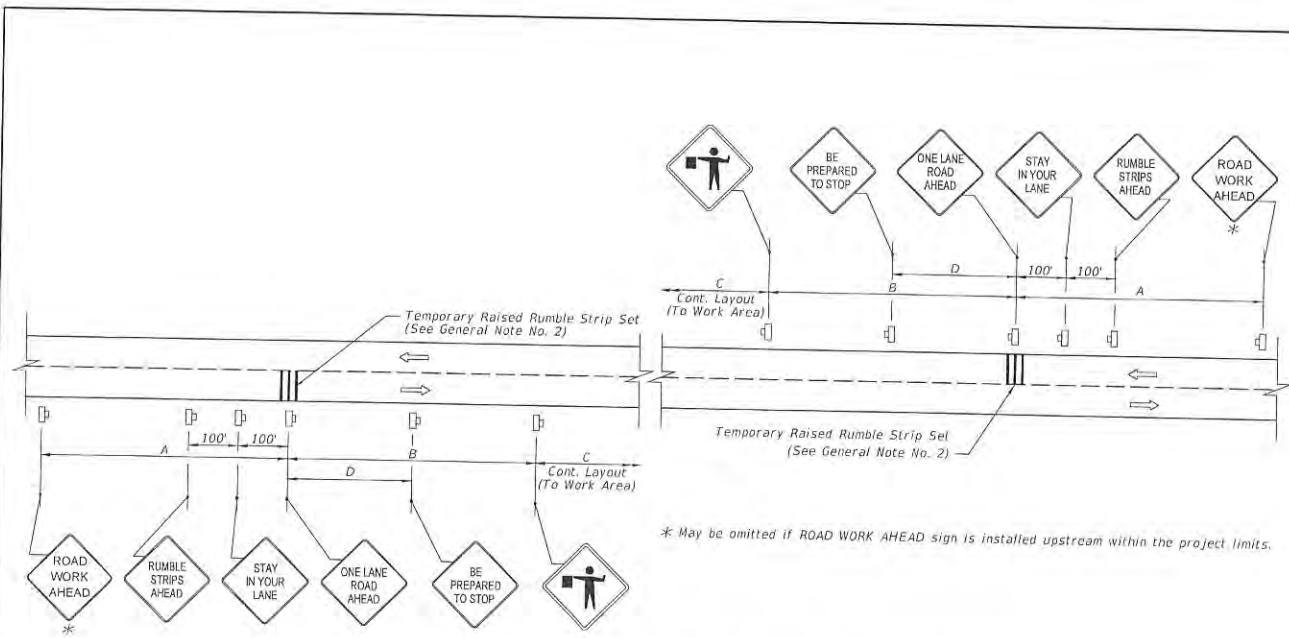

LAYOUT FOR TEMPORARY RAISED RUMBLE STRIPS WHEN REQUIRED WITH ADDITIONAL SIGNS

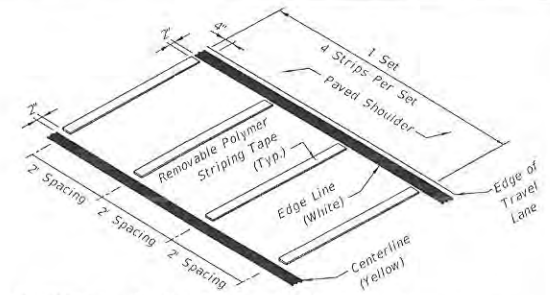

OPTION 1 - REMOVABLE POLYMER STRIPING TAPE RUMBLE STRIP SET

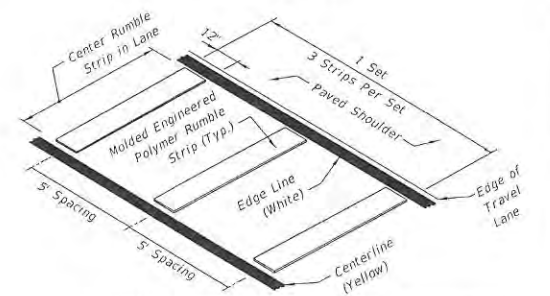

OPTION 2 - MOLDED ENGINEERED POLYMER RUMBLE STRIP SET

TEMPORARY RAISED RUMBLE STRIPS

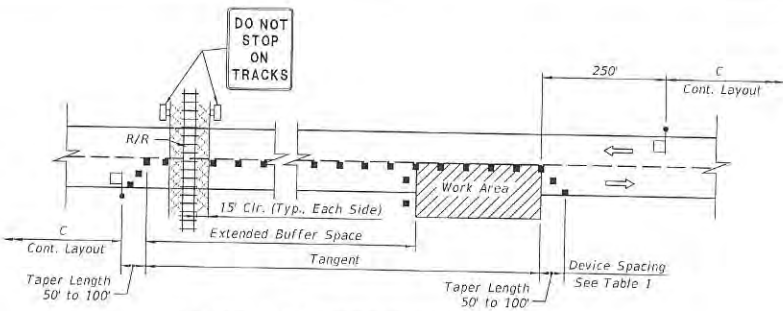

LAYOUT FOR RAILROAD CROSSING BUFFER SPACE EXTENSION

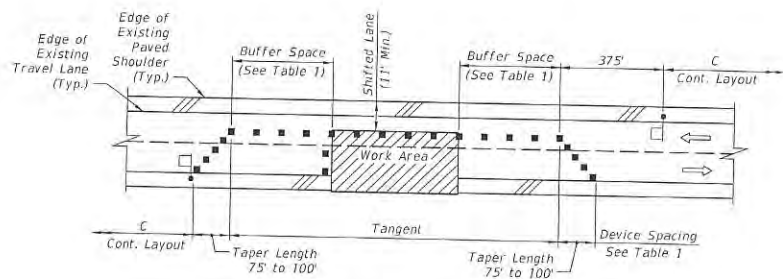

LAYOUT FOR TEMPORARY LANE SHIFT TO SHOULDER WHEN WORK AREA ENCREACHES ON THE CENTERLINE

LAST REVISION 07/01/15	REVISION	DESCRIPTION:	FDOT 2016 DESIGN STANDARDS	TWO-LANE, TWO-WAY, WORK WITHIN THE TRAVEL WAY	SPECIAL CONDITIONS	INDEX NO. 603	SHEET NO. 2 of 3
---------------------------	----------	--------------	----------------------------------	--	--------------------	------------------	---------------------

6/16/2015 10:46:46 AM

**AUTOMATED FLAGGER ASSISTANCE DEVICES NOTES:**

1. Illuminate the flagging station when the AFAD is used at nighttime.
2. When the AFAD is not in use, remove or cover signs and move AFAD device outside the clear zone or shield it with a barrier or crash cushion.
3. Only qualified flaggers who have been trained in the operation of the AFAD may operate the AFAD. When in use, each AFAD must be in view of and attended at all times by the flagger operating the device. Use two flaggers and one of the following methods in the deployment of AFAD's:
  - Method 1: Place an AFAD at each end of the temporary traffic control zone.
  - Method 2: Place an AFAD at one end of the temporary traffic control zone and a flagger at the opposite end.
4. A single flagger may simultaneously operate two AFAD's (Method 1) or may operate a single AFAD on one end of the temporary traffic control zone while being the flagger at the opposite end of the temporary traffic control zone (Method 2) if all four of the following conditions are present:
  - a. The flagger has an unobstructed view of the AFAD(s);
  - b. The flagger has an unobstructed view of approaching traffic in both directions;
  - c. For Method 1, the AFAD's are less than 800 ft apart. For Method 2, the AFAD and the flagger are less than 800 ft apart.
  - d. Two trained flaggers are available on-site to provide normal flagging operations should an AFAD malfunction.

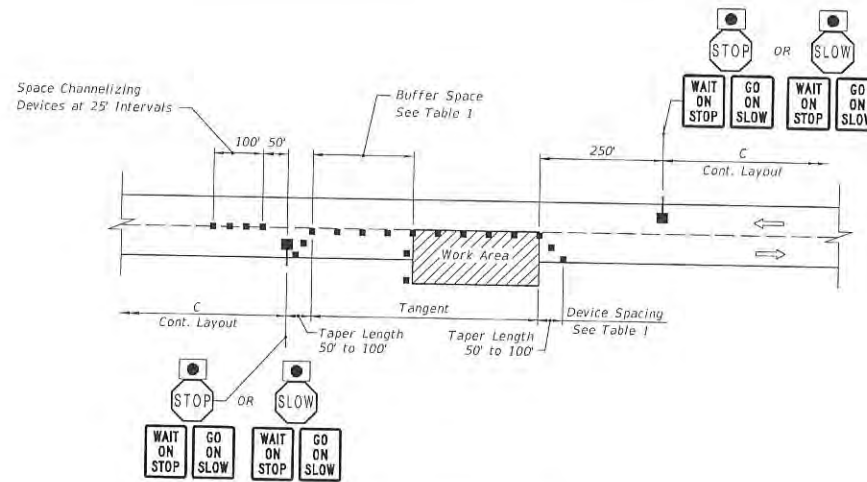

LAYOUT FOR STOP/SLOW AFAD  
METHOD 1 - 2 AFAD'S

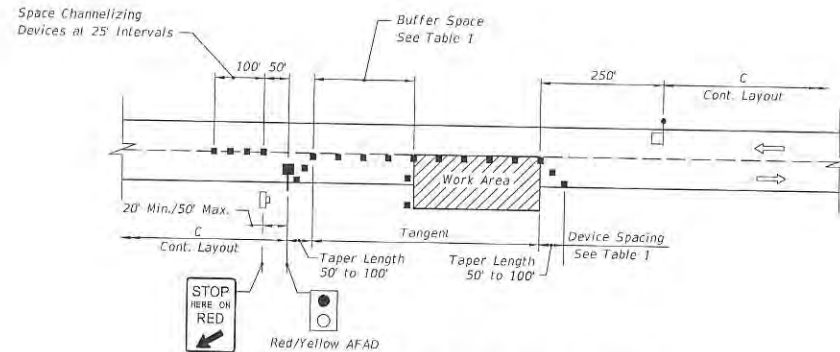

LAYOUT FOR RED/YELLOW AFAD  
METHOD 2 - 1 AFAD & FLAGGER

**AUTOMATED FLAGGER ASSISTANCE DEVICES (AFADs)**

LAST REVISION 07/01/15	REVISION	DESCRIPTION:	2016 DESIGN STANDARDS	TWO-LANE, TWO-WAY, WORK WITHIN THE TRAVEL WAY	INDEX NO. 603	SHEET NO. 3 of 3
---------------------------	----------	--------------	--------------------------	--	------------------	---------------------



# 8

**COLUMBIA COUNTY BOARD OF COUNTY COMMISSIONERS  
AGENDA ITEM REQUEST FORM**

The Board of County Commissioners meets the 1st and 3rd Thursday of each month at 5:30 p.m. in the Columbia County School Board Administrative Complex Auditorium, 372 West Duval Street, Lake City, Florida 32055. All agenda items are due in the Board's office one week prior to the meeting date.

Today's Date: February 14, 2017 Meeting Date: March 2, 2017

Name: Kevin Kirby Department: Public Works Department

Division Manager's Signature: 

**1. Nature and purpose of agenda item:**

**Permission to enter private property for the purpose of removal of several trees on the county right of way that fell onto property owned by Charles Deas. I am requesting permission to enter the property to remove the trees at the location of SW Bunn Drive.**

Attach any correspondence information, documents and forms for action i.e., contract agreements, quotes, memorandums, etc.

**2. Fiscal impact on current budget.**

Is this a budgeted item?  N/A  
 Yes Account No. \_\_\_\_\_  
 No Please list the proposed budget amendment to fund this request

Budget Amendment Number: \_\_\_\_\_ Fund: \_\_\_\_\_

FROM: \_\_\_\_\_ TO: \_\_\_\_\_ AMOUNT: \_\_\_\_\_

**For Use of County Manger Only:**

Consent Item  Discussion Item

District No. 1 - Ronald Williams  
District No. 2 - Rusty DePratter  
District No. 3 - Bucky Nash  
District No. 4 - Everett Phillips  
District No. 5 - Tim Murphy



**BOARD OF COUNTY COMMISSIONERS • COLUMBIA COUNTY**

MEMORANDUM

TO: Ben Scott, County Manager

FROM: Kevin Kirby, Assistant County Manager

DATE: February 13, 2017

RE: Permission to Enter Private Property

During the recent storm, several trees on the county right-of-way were uprooted and fell onto property owned by Charles Deas (see attached map.)

I am requesting permission to enter the property to remove the trees.

Upon approval the appropriate Hold Harmless Agreement will be obtained.

BOARD MEETS FIRST THURSDAY AT 5:30 P.M.  
AND THIRD THURSDAY AT 5:30 P.M.



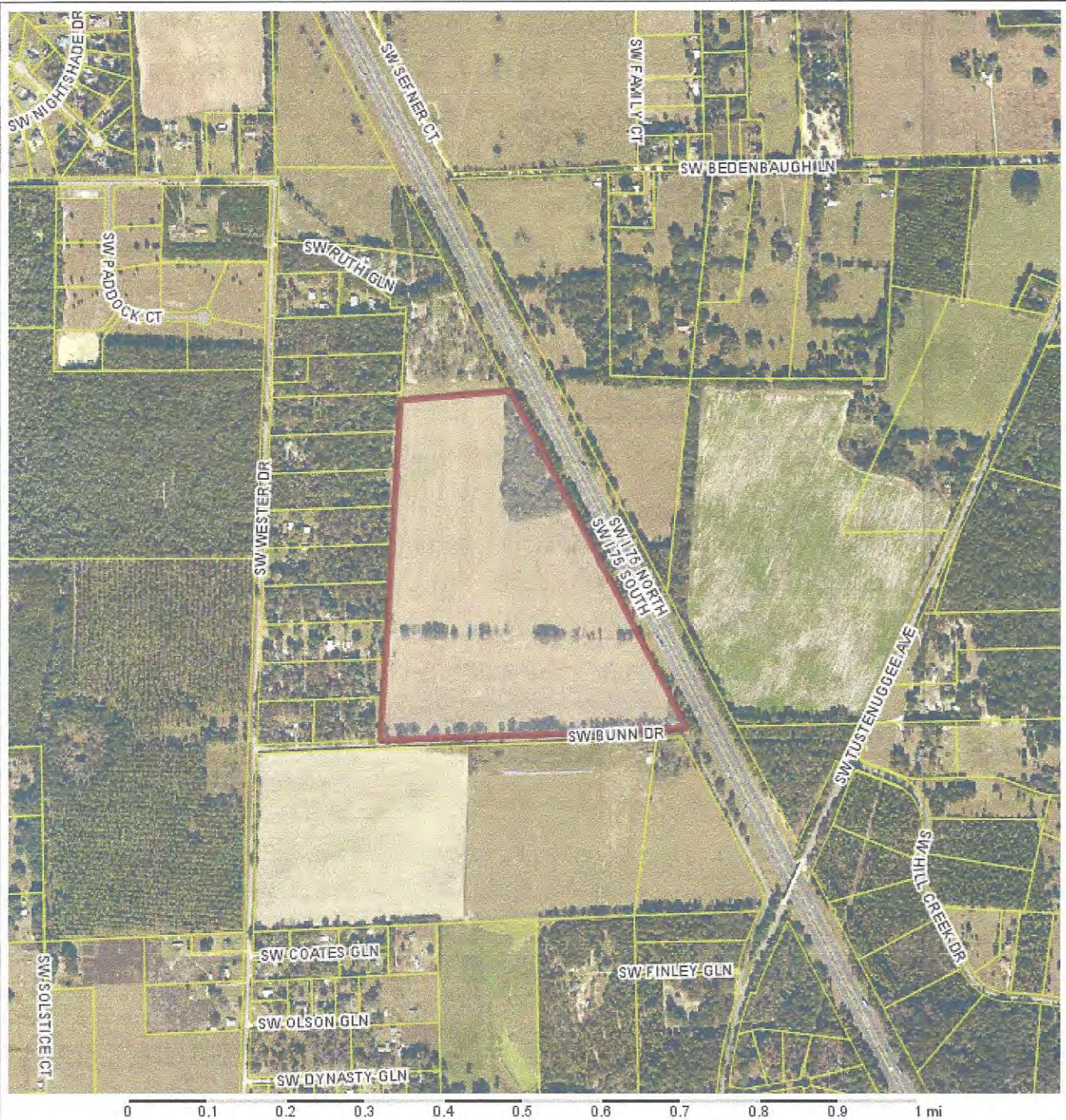

**Columbia County Property Appraiser**

Jeff Hampton | Lake City, Florida | 386-758-1083

**PARCEL: 31-4S-17-08915-014** | PASTURELAN (006200) | 74.57 AC

NOTES:

COMM AT SE COR OF SE 1/4 OF SEC RUN N ALONG SEC LINE, 1235.68 FT TO N R/W OF SW BUNN DRIVE, FOR POB, N 342.88 FT TO SW R/W OF I-75, NW ALONG R/W 2227.0

**Owner: DEAS CHARLES E & ANGELA L**

**2016 Certified Values**

MILLARD (JTWRs)  
169 SE HORACE WITT WAY  
LAKE CITY, FL 32025

Mkt Lnd	\$0	Appraised	\$17,151
Ag Lnd	\$17,151	Exempt	\$0
Bldg	\$0	Assessed	\$17,151
XFOB	\$0	<b>county:</b>	\$17,151
Just	\$169,804	<b>city:</b>	\$17,151
Class	\$17,151	<b>other:</b>	\$17,151
		<b>school:</b>	\$17,151

Site: WESTER RD,  
Sales 8/2/2015 \$3,000 V (U)  
Info 1/31/2014 \$221,300 V (Q)



This information, updated: 2/1/2017, was derived from data which was compiled by the Columbia County Property Appraiser Office solely for the governmental purpose of property assessment. This information should not be relied upon by anyone as a determination of the ownership of property or market value. No warranties, expressed or

by: GrizzlyLogic.com









# 9

**COLUMBIA COUNTY BOARD OF COUNTY COMMISSIONERS  
AGENDA ITEM REQUEST FORM**

The Board of County Commissioners meets the 1st and 3rd Thursday of each month at 5:30 p.m. in the Columbia County School Board Administrative Complex Auditorium, 372 West Duval Street, Lake City, Florida 32055. All agenda items are due in the Board's office one week prior to the meeting date.

Today's Date: February 16, 2017 Meeting Date: March 2, 2017

Name: Kevin Kirby Department: Public Works Department

Division Manager's Signature: 

**1. Nature and purpose of agenda item:**

I am requesting permission to enter private property after the fact. During the recent storm event of February 7, 2017 several trees on the county right-a-way fell across a fence and onto the property owned by Everett (Arky) Rogers known as parcel #09068-000.

Attach any correspondence information, documents and forms for action i.e., contract agreements, quotes, memorandums, etc.

**2. Fiscal impact on current budget.**

Is this a budgeted item?  N/A  
 Yes Account No. \_\_\_\_\_  
 No Please list the proposed budget amendment to fund this request

Budget Amendment Number: \_\_\_\_\_ Fund: \_\_\_\_\_

FROM: \_\_\_\_\_ TO: \_\_\_\_\_ AMOUNT: \_\_\_\_\_

**For Use of County Manger Only:**

Consent Item  Discussion Item



District No. 1 - Ronald Williams  
District No. 2 - Rusty DePratter  
District No. 3 - Bucky Nash  
District No. 4 - Everett Phillips  
District No. 5 - Tim Murphy

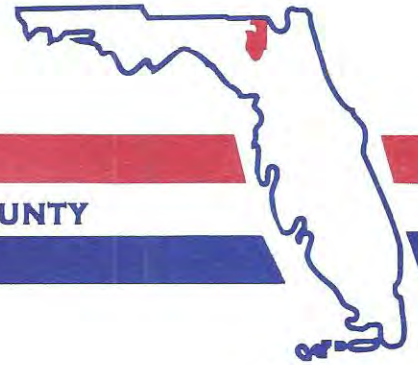

**BOARD OF COUNTY COMMISSIONERS • COLUMBIA COUNTY**

MEMORANDUM

TO: Ben Scott, County Manager

FROM: Kevin Kirby, Assistant County Manager

DATE: February 15, 2017

RE: Permission to Enter Private Property

I am requesting permission to enter private property after the fact. During the recent storm event of February 7, 2017 several trees on the county right-of-way fell across a fence and onto the property owned by Everett (Arky) Rogers known as parcel #09068-000.

Due to the time sensitivity and the effect on Mr. Roger's cattle operation it was necessary to remove the trees as soon as possible.

The appropriate Hold Harmless Agreement was signed.





02-5S-17-09068-000  
 ROGERS EVERETT W & DEBORAH M  
 78AC

0 0.2 0.4 0.6 0.8 1 1.2 1.4 1.6 1.8 2 mi

**Columbia County Property Appraiser**

Jeff Hampton - Lake City, Florida 32055 | 386-758-1083

**PARCEL: 02-5S-17-09068-000 - PASTURELAN (006200)**

S1/2 OF SW1/4, EX RD. ORB 458-107, 458-162 & 1021-2390.

NOTES:

Name: ROGERS EVERETT W & DEBORAH M		<b>2016 Certified Values</b>	
Site:		Land	\$0.00
		Bldg	\$0.00
Mail: TRUSTEES OF THE ARKY ROGERS LAND TRUST		Assd	\$17,796.00
8355 SOUTH US HWY 441		Exmpt	\$0.00
LAKE CITY, FL 32025		Taxbl	Cnty: \$17,796
Sales Info: NONE			Other: \$17,796   Schl: \$17,796





GENERAL RELEASE AND HOLD HARMLESS AGREEMENT

The undersigned private property owner, Everett (Arky) Rogers, and COLUMBIA COUNTY, FLORIDA, by and through its representative Rick Coulombe, "County", hereby agree as follows:

WHEREAS, Owner agrees for County to enter upon Owner's property identified as parcel # 09068-000 for the purpose of tree removal.

WHERE, Owner authorizes County to enter upon Owner's private property and release County from liability as a result thereof, and

WHEREAS, County agrees to hold Owner harmless from liability as a result of County's actions upon Owner's property.

NOW THEREFORE, in consideration of the mutual covenants set forth herein the parties agree as follows:

1. Owner hereby authorizes County and its representatives to enter upon Owner's property for the purpose of tree removal.
2. Owner hereby releases County together with its agents, representatives and employees from any and all actions, cause of actions or liability, including for trespass damages or other claims or demands whatsoever, in law or in equity as a result of County's actions upon Owner's property, so long as the same is not done in any grossly negligent manner.
3. County hereby agrees to hold Owner harmless from any liability as a result of County's actions upon Owner's property or the actions of any third parties, which may enter on Owner's property upon County's direction or authorization.

Dated this 15<sup>th</sup> day of FEBRUARY, 2017.

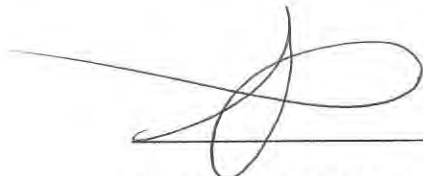
  
\_\_\_\_\_

PROPERTY OWNER SIGNATURE

  
\_\_\_\_\_  
COLUMBIA COUNTY REPRESENTATIVE  
Rick Coulombe, Tree Crew Foreman









# 10

COLUMBIA COUNTY BOARD OF COUNTY COMMISSIONERS
AGENDA ITEM REQUEST FORM

The Board of County Commissioners meets the 1st and 3rd Thursday of each month at 5:30 p.m. in the Columbia County School Board Administrative Complex Auditorium, 372 West Duval Street, Lake City, Florida 32055. All agenda items are due in the Board's office one week prior to the meeting date.

Today's Date: February 22, 2017 Meeting Date: March 2, 2017

Name: Kevin Kirby Department: Public Works Department

Division Manager's Signature: [Handwritten Signature]

1. Nature and purpose of agenda item:

I am requesting permission to enter private property located at 1152 SW Little Road for the purpose of dangerous tree removal.

Attach any correspondence information, documents and forms for action i.e., contract agreements, quotes, memorandums, etc.

2. Fiscal impact on current budget.

Is this a budgeted item? [X] N/A [ ] Yes Account No. [ ] No Please list the proposed budget amendment to fund this request

Budget Amendment Number: Fund:

FROM: TO: AMOUNT:

For Use of County Manger Only:

[X] Consent Item [ ] Discussion Item

District No. 1 - Ronald Williams  
District No. 2 - Rusty DePratter  
District No. 3 - Bucky Nash  
District No. 4 - Everett Phillips  
District No. 5 - Tim Murphy

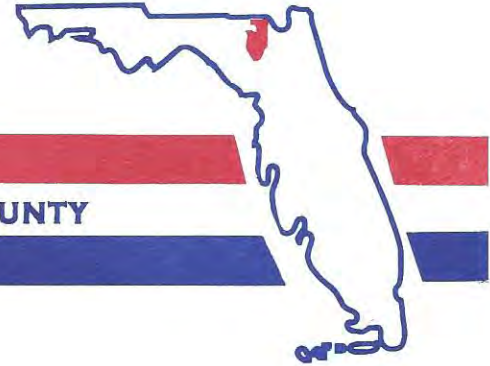

**BOARD OF COUNTY COMMISSIONERS • COLUMBIA COUNTY**

MEMORANDUM

TO: Ben Scott, County Manager

FROM: Kevin Kirby, Assistant County Manager

A handwritten signature in blue ink, appearing to be 'K Kirby', written over the 'FROM' line.

DATE: February 22, 2017

RE: Entering Private Property

I am requesting permission to enter private property located at 1152 SW Little Road for the purpose of dangerous tree removal.

The tree is on the County right-of-way but access to the owner's property will be necessary for clean-up.

Upon approval the appropriate Hold Harmless Agreement will be obtained.

Your consideration is appreciated.

BOARD MEETS FIRST THURSDAY AT 5:30 P.M.  
AND THIRD THURSDAY AT 5:30 P.M.















